

BS EN ISO 12572:2016



BSI Standards Publication

**Hygrothermal performance  
of building materials and  
products — Determination of  
water vapour transmission  
properties — Cup method  
(ISO 12572:2016)**

**bsi.**

**National foreword**

This British Standard is the UK implementation of EN ISO 12572:2016. It supersedes BS EN ISO 12572:2001 which is withdrawn.

The UK participation in its preparation was entrusted to Technical Committee B/540, Energy performance of materials components and buildings.

A list of organizations represented on this committee can be obtained on request to its secretary.

This publication does not purport to include all the necessary provisions of a contract. Users are responsible for its correct application.

© The British Standards Institution 2016.  
Published by BSI Standards Limited 2016

ISBN 978 0 580 85191 9

ICS 91.100.01

**Compliance with a British Standard cannot confer immunity from legal obligations.**

This British Standard was published under the authority of the Standards Policy and Strategy Committee on 31 August 2016.

**Amendments/corrigenda issued since publication**

Date	Text affected
------	---------------

---

EUROPEAN STANDARD

**EN ISO 12572**

NORME EUROPÉENNE

EUROPÄISCHE NORM

August 2016

ICS 91.120.10

Supersedes EN ISO 12572:2001

English Version

## Hygrothermal performance of building materials and products - Determination of water vapour transmission properties - Cup method (ISO 12572:2016)

Performance hygrothermique des matériaux et produits pour le bâtiment - Détermination des propriétés de transmission de la vapeur d'eau - Méthode de la coupelle (ISO 12572:2016)

Wärme- und feuchtetechnisches Verhalten von Baustoffen und Bauprodukten - Bestimmung der Wasserdampfdurchlässigkeit - Verfahren mit einem Prüfgefäß (ISO 12572:2016)

This European Standard was approved by CEN on 16 July 2016.

CEN members are bound to comply with the CEN/CENELEC Internal Regulations which stipulate the conditions for giving this European Standard the status of a national standard without any alteration. Up-to-date lists and bibliographical references concerning such national standards may be obtained on application to the CEN-CENELEC Management Centre or to any CEN member.

This European Standard exists in three official versions (English, French, German). A version in any other language made by translation under the responsibility of a CEN member into its own language and notified to the CEN-CENELEC Management Centre has the same status as the official versions.

CEN members are the national standards bodies of Austria, Belgium, Bulgaria, Croatia, Cyprus, Czech Republic, Denmark, Estonia, Finland, Former Yugoslav Republic of Macedonia, France, Germany, Greece, Hungary, Iceland, Ireland, Italy, Latvia, Lithuania, Luxembourg, Malta, Netherlands, Norway, Poland, Portugal, Romania, Slovakia, Slovenia, Spain, Sweden, Switzerland, Turkey and United Kingdom.



EUROPEAN COMMITTEE FOR STANDARDIZATION  
COMITÉ EUROPÉEN DE NORMALISATION  
EUROPÄISCHES KOMITEE FÜR NORMUNG

**CEN-CENELEC Management Centre: Avenue Marnix 17, B-1000 Brussels**

## **European foreword**

This document (EN ISO 12572:2016) has been prepared by Technical Committee CEN/TC 89 “Thermal performance of buildings and building components” the secretariat of which is held by SIS, in collaboration with Technical Committee ISO/TC 163 “Thermal performance and energy use in the built environment”.

This European Standard shall be given the status of a national standard, either by publication of an identical text or by endorsement, at the latest by February 2017, and conflicting national standards shall be withdrawn at the latest by February 2017.

Attention is drawn to the possibility that some of the elements of this document may be the subject of patent rights. CEN [and/or CENELEC] shall not be held responsible for identifying any or all such patent rights.

This document supersedes EN ISO 12572:2001.

According to the CEN-CENELEC Internal Regulations, the national standards organizations of the following countries are bound to implement this European Standard: Austria, Belgium, Bulgaria, Croatia, Cyprus, Czech Republic, Denmark, Estonia, Finland, Former Yugoslav Republic of Macedonia, France, Germany, Greece, Hungary, Iceland, Ireland, Italy, Latvia, Lithuania, Luxembourg, Malta, Netherlands, Norway, Poland, Portugal, Romania, Slovakia, Slovenia, Spain, Sweden, Switzerland, Turkey and the United Kingdom.

### **Endorsement notice**

The text of ISO 12572:2016 has been approved by CEN as EN ISO 12572:2016 without any modification.

# Contents

Page

<b>Foreword</b> .....	<b>v</b>
<b>1 Scope</b> .....	<b>1</b>
<b>2 Normative references</b> .....	<b>1</b>
<b>3 Terms, definitions, symbols, units and subscripts</b> .....	<b>1</b>
3.1 Terms and definitions.....	1
3.2 Symbols and units.....	2
3.3 Subscripts.....	3
<b>4 Principle</b> .....	<b>3</b>
<b>5 Apparatus</b> .....	<b>3</b>
<b>6 Test specimens</b> .....	<b>4</b>
6.1 General principles for preparation of test specimens.....	4
6.2 Dimensions of test specimens.....	4
6.2.1 Shape and fit.....	4
6.2.2 Exposed area.....	4
6.2.3 Thickness of test specimens.....	4
6.3 Number of test specimens.....	5
6.4 Conditioning of test specimens.....	5
6.5 Testing low resistance specimens.....	5
<b>7 Procedure</b> .....	<b>5</b>
7.1 Test conditions.....	5
7.2 Preparation of specimen and test assembly.....	7
7.3 Test procedure.....	7
<b>8 Calculation and expression of results</b> .....	<b>8</b>
8.1 Mass change rate.....	8
8.2 Density of water vapour flow rate.....	9
8.3 Water vapour permeance.....	9
8.4 Water vapour resistance.....	10
8.5 Water vapour permeability.....	10
8.6 Water vapour resistance factor.....	10
8.7 Water vapour diffusion-equivalent air layer thickness.....	11
<b>9 Accuracy of measurement</b> .....	<b>11</b>
9.1 General.....	11
9.2 Specimen area.....	11
9.3 Specimen thickness.....	11
9.4 Sealants.....	12
9.5 Weighing precision.....	12
9.6 Control of environmental conditions.....	12
9.7 Variations in barometric pressure during test.....	12
<b>10 Test report</b> .....	<b>12</b>
<b>Annex A (normative) Methods suitable for self-supporting materials</b> .....	<b>14</b>
<b>Annex B (normative) Methods suitable for loose fills</b> .....	<b>16</b>
<b>Annex C (normative) Methods suitable for membranes and foils</b> .....	<b>18</b>
<b>Annex D (normative) Methods suitable for mastics and sealants</b> .....	<b>19</b>
<b>Annex E (normative) Methods suitable for paint, varnishes, etc.</b> .....	<b>21</b>
<b>Annex F (normative) Correction for the effect of a masked edge of a specimen</b> .....	<b>22</b>
<b>Annex G (normative) Correction for resistance of air layers</b> .....	<b>24</b>

<b>Annex H (normative) Method for calculating the water vapour resistance of the air layer in the cup</b> .....	<b>25</b>
<b>Annex I (informative) Weighing repeatability, weighing interval and specimen size needed to achieve desired accuracy</b> .....	<b>26</b>
<b>Annex J (informative) Conversion table for water vapour transmission units</b> .....	<b>27</b>
<b>Bibliography</b> .....	<b>28</b>

## Foreword

ISO (the International Organization for Standardization) is a worldwide federation of national standards bodies (ISO member bodies). The work of preparing International Standards is normally carried out through ISO technical committees. Each member body interested in a subject for which a technical committee has been established has the right to be represented on that committee. International organizations, governmental and non-governmental, in liaison with ISO, also take part in the work. ISO collaborates closely with the International Electrotechnical Commission (IEC) on all matters of electrotechnical standardization.

The procedures used to develop this document and those intended for its further maintenance are described in the ISO/IEC Directives, Part 1. In particular the different approval criteria needed for the different types of ISO documents should be noted. This document was drafted in accordance with the editorial rules of the ISO/IEC Directives, Part 2 (see [www.iso.org/directives](http://www.iso.org/directives)).

Attention is drawn to the possibility that some of the elements of this document may be the subject of patent rights. ISO shall not be held responsible for identifying any or all such patent rights. Details of any patent rights identified during the development of the document will be in the Introduction and/or on the ISO list of patent declarations received (see [www.iso.org/patents](http://www.iso.org/patents)).

Any trade name used in this document is information given for the convenience of users and does not constitute an endorsement.

For an explanation on the meaning of ISO specific terms and expressions related to conformity assessment, as well as information about ISO's adherence to the World Trade Organization (WTO) principles in the Technical Barriers to Trade (TBT) see the following URL: [www.iso.org/iso/foreword.html](http://www.iso.org/iso/foreword.html)

ISO 12572 was prepared by the European Committee Standardization (CEN) Technical Committee CEN/TC 89, *Thermal performance of buildings and building components*, in collaboration with ISO Technical Committee ISO/TC 163, *Thermal performance and energy use in the built environment*, Subcommittee SC 1, *Test and measurement methods*, in accordance with the agreement on technical cooperation between ISO and CEN (Vienna Agreement).

This second edition cancels and replaces the first edition (ISO 12572:2001), which has been technically revised with the following changes:

- addition of insulation materials in the Scope;
- addition of e) humidity chamber in [Clause 5](#);
- addition of requirements regarding thickness of test specimen to measure the permeability of core materials in [6.2.3](#);
- change of specimen area size in [6.3](#);
- addition of requirements for storage time and relative humidity for condition D in [6.4](#);
- new clause with requirements in [6.5](#);
- change of requirements for temperature and relative humidity for test conditions in [7.1](#);
- change of the calculation of mass change rate in [8.1](#);
- removal of 9.8.





# Hygrothermal performance of building materials and products — Determination of water vapour transmission properties — Cup method

## 1 Scope

This document specifies a method based on cup tests for determining the water vapour permeance of building products and the water vapour permeability of building materials under isothermal conditions. Different sets of test conditions are specified.

The general principles are applicable to all hygroscopic and non-hygroscopic building materials and products, including insulation materials and including those with facings and integral skins. Annexes give details of test methods suitable for different material types.

The results obtained by this method are suitable for design purposes, production control and for inclusion in product specifications.

## 2 Normative references

The following documents are referred to in the text in such a way that some or all of their content constitutes requirements of this document. For dated references, only the edition cited applies. For undated references, the latest edition of the referenced document (including any amendments) applies.

There are no normative references in this document.

## 3 Terms, definitions, symbols, units and subscripts

### 3.1 Terms and definitions

For the purposes of this document, the terms and definitions given in ISO 9346 and the following apply.

ISO and IEC maintain terminological databases for use in standardization at the following addresses:

- IEC Electropedia: available at <http://www.electropedia.org/>
- ISO Online browsing platform: available at <http://www.iso.org/obp>

#### 3.1.1

##### **density of water vapour flow rate**

mass of water vapour transferred through the specimen per area and per time

#### 3.1.2

##### **homogeneous material**

material with properties likely to affect the transmission of water vapour which do not vary on a macroscopic scale

#### 3.1.3

##### **impermeable material**

material with a measured *water vapour diffusion-equivalent air layer thickness* (3.1.8) greater than 1 500 m

#### 3.1.4

##### **water vapour permeance**

*density of water vapour flow rate* (3.1.1) divided by the water vapour pressure difference between the two specimen faces

### 3.1.5

#### water vapour resistance

reciprocal of *water vapour permeance* ([3.1.4](#))

### 3.1.6

#### water vapour permeability

product of the *water vapour permeance* ([3.1.4](#)) and the thickness of a homogeneous specimen

Note 1 to entry: Water vapour permeability can only be calculated for specimens of a *homogeneous material* ([3.1.2](#)).

### 3.1.7

#### water vapour resistance factor

*water vapour permeability* ([3.1.6](#)) of air divided by that of the material concerned

Note 1 to entry: The water vapour resistance factor indicates how much greater the resistance of the material is compared to an equally thick layer of stationary air at the same temperature.

### 3.1.8

#### water vapour diffusion-equivalent air layer thickness

thickness of a motionless air layer which has the same *water vapour resistance* ([3.1.5](#)) as the specimen

## 3.2 Symbols and units

Symbol	Quantity	Unit
$A$	area of specimen	m <sup>2</sup>
$G$	water vapour flow rate through specimen	kg/s
$R_v$	gas constant for water vapour = 462	N·m/(kg·K)
$S$	hydraulic diameter of specimen	m
$T$	thermodynamic temperature	K
$W_p$	water vapour permeance with respect to partial vapour pressure	kg/(m <sup>2</sup> ·s·Pa)
$Z_p$	water vapour resistance with respect to partial vapour pressure	m <sup>2</sup> ·s·Pa/kg
$d$	mean thickness of specimen	m
$g$	density of water vapour flow rate	kg/(m <sup>2</sup> ·s)
$l$	diameter of circle or side of square specimen	m
$m$	mass of specimen and cup assembly	kg
$p$	barometric pressure	hPa
$p_0$	standard barometric pressure = 1 013,25	hPa
$S_d$	water vapour diffusion-equivalent air layer thickness	m
$t$	time	s
$\Delta p_v$	water vapour pressure difference across specimen	Pa
$\delta_p$	water vapour permeability	kg/(m·s·Pa)
$\delta_a$	water vapour permeability of air	kg/(m·s·Pa)
$\mu$	water vapour resistance factor	—
$\theta$	celsius temperature	°C
$\varphi$	relative humidity	—

NOTE The above units comply with ISO 9346; a conversion table to other units commonly used in permeability measurements is given in [Annex J](#).

### 3.3 Subscripts

Subscript	Denoting
I	interval
r	repeatability
a	air
c	corrected for air layer
f	film
j	joint
m	membrane
me	masked edge
s	specimen
t	total

## 4 Principle

The test specimen is sealed to the open side of a test cup containing either a desiccant (dry cup) or an aqueous saturated solution (wet cup). The assembly is then placed in a temperature and humidity controlled test chamber. Because of the different partial vapour pressure between the test cup and the chamber, a vapour flow occurs through permeable specimens. Periodic weighings of the assembly are made to determine the rate of water vapour transmission in the steady-state.

## 5 Apparatus

- a) Test cups resistant to corrosion from the desiccant or salt solutions they contain; typically cups are made of glass or metal.

The design of cups suitable for testing various different types of materials is described in [Annexes A to E](#).

NOTE Circular cups can be easier to seal and transparent cups allow better control of salt solutions.

- b) For certain cups and sealing methods (see [Annex A](#)), a template, with shape and size corresponding to that of the test cup, is used when applying the sealant to give a sharply defined, reproducible test area. The template shall have an area of at least 90 % of the specimen to limit nonlinear vapour flow.
- c) Measuring instruments capable of determining specimen thickness with accuracy required in [7.2](#).
- d) Analytical balance, capable of weighing the test assembly with the repeatability needed for the required accuracy. Wherever possible, a balance of 0,001 g resolution shall be used. For heavy test assemblies, a balance resolution of 0,01 g may be sufficient (see [Annex I](#) for information linking the balance resolution to the duration of test).

NOTE The factors that affect the necessary accuracy of measurement are discussed in [Annex I](#).

- e) Constant temperature, constant humidity chamber, capable of being maintained within  $\pm 5$  % relative humidity around the set point relative humidity and  $\pm 1,0$  K around the set point temperature. In order to ensure uniform conditions throughout the chamber, the air shall be stirred so as to obtain velocities between 0,02 m/s and 0,3 m/s. If highly permeable materials are being tested, means should be provided to measure the air speed directly over the upper surface of the specimen (see [Annex G](#)).
- f) Suitable sensors and a logging system to continuously record the temperature, relative humidity and, if necessary, the barometric pressure within the test chamber. The sensors shall be calibrated at regular intervals.

- g) Sealant, which is impermeable to water vapour, does not undergo physical or chemical changes during the test and does not cause physical or chemical changes to the specimen.

NOTE Examples of sealants suitable for specific materials, if necessary, are listed in the appropriate Annex.

## 6 Test specimens

### 6.1 General principles for preparation of test specimens

The test specimens shall be representative of the product. If the product has natural skins or integral facings, these may be included in the test specimen, but they shall be removed if it is intended to measure the permeability of the core material. If the skins or facings are different on the two sides, specimens shall be tested with vapour flow in the direction of the intended use. If the direction of flow is not known, duplicate specimens shall be prepared and tests carried out for each direction of flow. Unless the product to be tested is isotropic, the test specimens shall be cut so that the parallel faces are normal to the direction of vapour flow of the product in use.

Specimen preparation shall not involve methods which damage the surface in ways which affect the flow of water vapour.

### 6.2 Dimensions of test specimens

#### 6.2.1 Shape and fit

Test specimens shall be cut to correspond with the dimensions of the chosen test assembly (see [Annexes A to E](#)).

#### 6.2.2 Exposed area

The diameter of a circular specimen or the side of a square specimen shall be at least twice the specimen thickness. The exposed area (the arithmetic mean of the upper and lower free surface areas) shall be at least 0,005 m<sup>2</sup>. The upper and lower free surface areas shall not differ by more than 3 % of the mean in the case of homogeneous materials and by no more than 10 % in the case of other materials.

#### 6.2.3 Thickness of test specimens

Whenever possible, the thickness of the specimen shall be that of the product in use. In the case of homogeneous materials, if the thickness exceeds 100 mm, this may be reduced by cutting. In the case of non-homogeneous materials, such as concrete containing aggregates, the thickness should be at least three times (and preferably five times) the largest particle size.

If a material contains macroscopic formed voids, the solid material should be tested and the resistance of the whole material calculated from the proportions of solid to air space assuming one dimensional vapour flow.

If it is necessary to test a product so thick that the available test cups do not have an area large enough to comply with [6.2.2](#), the product may, only as a last resort, be sliced. In this case, all slices shall be tested and the results reported.

If it is intended to measure the permeability of the core material, all skins and facings shall be removed and the test specimens shall have a thickness of at least 20 mm.

NOTE There is a risk that this procedure leads to significant inaccuracies, especially when wet cup tests are carried out on hygroscopic materials.

### 6.3 Number of test specimens

If the specimen area is less than 0,05 m<sup>2</sup>, a minimum of five specimens shall be tested, otherwise a minimum of three specimens shall be tested.

### 6.4 Conditioning of test specimens

Before testing, the test specimens shall be stored at (23 ± 5) °C, (50 ± 5) % relative humidity for a period long enough for their weight to stabilize so that three successive daily determinations of their weight agree to within 5 %; a storage time of at least 6 h is necessary. If condition D in [Table 1](#) is to be used, the specimens should be conditioned at (38 ± 5) °C, (50 ± 5) % relative humidity.

NOTE This period will vary from a few hours in the case of some insulating materials to three to four weeks, or more, for massive hygroscopic materials and products.

Wet field specimens may be dried before conditioning using the methods specified in ISO 12570.

A period of conditioning is not necessary in the case of plastic membranes.

### 6.5 Testing low resistance specimens

When testing low vapour resistance specimens with  $S_d < 0,1$  m, use a wet cup, with distilled water in the cup, giving a relative humidity of 100 % in the cup. The high flow rate through the specimen prevents the occurrence of condensation on the underside of the specimen that is a risk with higher resistance specimens. In this case, the size of the air gap between the water in the cup and the base of the specimen shall be known to the nearest mm, and it is essential to maintain sufficient airspeed over the top surface of the specimen (see [Annex G](#)).

NOTE Testing low vapour resistance specimens, with  $S_d < 0,1$  m, can be difficult with either a wet cup or a dry cup, because the water flow out of or into the cup can be large enough to affect the performance of the saturated salt solution or desiccant before the test is complete. It is not therefore possible to carry out "dry cup" tests with this type of material.

## 7 Procedure

### 7.1 Test conditions

Select the desired test environment from the conditions given in [Table 1](#).

Table 1 — Test conditions

Set	Condition °C - % RH	Temperature °C	Tolerances			
			Relative humidity <sup>a</sup>			
			%		%	
			Dry state		Wet state	
			Set point	Tolerance	Set point	Tolerance
A	23 – 0/50	23 ± 1	0	+5	50	±5
B	23 – 0/85	23 ± 1	0	+5	85	±5
C	23 – 50/93	23 ± 1	50	±5	93	±5
D	38 – 0/93	38 ± 1	0	+5	93	±3
E	23 – 50/100	23 ± 1	50	±5	100	

NOTE 1 "Dry cup" tests (condition A) give information about the performance of materials at low humidities when moisture transfer is dominated by vapour diffusion. "Wet cup" tests (condition C) give guidance about the performance of materials under high humidity conditions. At higher humidities, the material pores start to fill with water; this increases the transport of liquid water and reduces vapour transport. Tests in this area therefore give some information about liquid water transport within materials. This is discussed further in ISO 15148.

NOTE 2 Condition E is used for low resistance specimens ( $S_d \leq 0,1$  m).

<sup>a</sup> Saturated salt solutions, which regulate the relative humidity in the cup at some value less than 100 %, are used because, with many materials, there is a danger of condensation occurring on the underside of the sample, which disrupts the vapour flow. In the case of very low resistance materials with  $S_d < 0,1$  m, the vapour flow rates are so high that a) condensation is unlikely and b) the saturated salt solution might not remain in equilibrium for the duration of the rest. In this case, that distilled water should be used in the test cup. Further information about the use of saturated salt solutions is given in 9.6.

Other sets of temperature and relative humidity may be agreed between the parties when needed for special application conditions.

EXAMPLE 1 This is an example of desiccants which produce the specified air relative humidities at 23 °C.

Desiccants

Calcium chloride, CaCl <sub>2</sub> - particle size < 3 mm	0 %
Magnesium perchlorate, Mg(ClO <sub>4</sub> ) <sub>2</sub>	0 %
Phosphorus pentoxide, P <sub>2</sub> O <sub>5</sub>	0 %
Silicagel	0 %

EXAMPLE 2 This is an example of saturated aqueous solutions which produce the specified air relative humidities at 23 °C.

Aqueous solutions

Sodium dichromate, Na <sub>2</sub> Cr <sub>2</sub> O <sub>7</sub> · 2H <sub>2</sub> O	52 %
Magnesium nitrate, Mg(NO <sub>3</sub> ) <sub>2</sub>	53 %
Potassium chloride, KCl	85 %
Ammonium dihydrogen phosphate, NH <sub>4</sub> H <sub>2</sub> PO <sub>4</sub>	93 %
Potassium nitrate, KNO <sub>3</sub>	94 %

Further details of suitable solutions can be found in ISO 12571:2013, Annexes A and B.

Regular checks shall be made, especially during long tests, to ensure that saturated solutions remain as a mixture of liquid with a large amount of undissolved substance.

All chemical substances shall be handled with care and in accordance with relevant safety regulations.

## 7.2 Preparation of specimen and test assembly

Prepare test specimens to correspond to the test assembly used (see [Annexes A to E](#)). Measure the thickness of specimens to the nearest 0,2 mm, or to an accuracy of  $\pm 0,5$  %, whichever is the more accurate. For rigid materials, measure the thickness of test specimens at four positions equally spaced around the circumference. Calculate the mean thickness of each test specimen. Record the procedure used to measure the effective thickness of compressible and loose-fill materials and of test specimens with irregular surfaces.

Place the desiccant or aqueous solution, with a minimum depth of 15 mm, in the bottom of each cup. Seal the test specimen into the cup, using the appropriate technique specified in the relevant Annex. The air space between the desiccant or saturated solution and the specimen shall be  $(15 \pm 5)$  mm. The thickness of this layer shall be measured to the nearest mm to allow for its resistance to be calculated (see [Annex H](#)).

NOTE 1 Once the distance between the base of the specimen and the desiccant or salt solution has been measured once, weighing the cup with its contents can be used to achieve a repeatable gap.

The resistance of the layer above the specimen shall be reduced to zero by arranging an appropriate air speed over the cup (see [Annex G](#)).

NOTE 2 The vapour flow rate depends on the vapour resistance of the specimen and the resistances of the air layers above and below the specimen. In the case of high resistance specimens, these air resistances are negligible, but for low resistance materials with  $S_d < 0,1$  m, they are significant.

Prepare a test assembly using a cup and sealant system suitable for the type of material under test (see [Annexes A to E](#)).

NOTE 3 The accuracy and repeatability of the results are strongly dependent on the quality of the sealing, especially for high resistance specimens. Therefore, close attention needs to be given to the method of applying sealing. Initial tests can be carried out with an impermeable metal specimen to test that the resultant vapour flow rate is zero. Further information on sealing is given in [9.4](#).

## 7.3 Test procedure

Place the test assemblies in the test chamber. Then, weigh in turn each test assembly at time intervals selected according to the specimen characteristics and to the repeatability of the weighing procedure.

NOTE [Annex I](#) gives guidance on the ways of reaching the required accuracy.

Weighings shall be carried out in an environment with a temperature within  $\pm 2$  °C of the test condition, wherever possible within the test chamber. [Figure 1](#) shows an arrangement for small chambers.

The temperature and relative humidity within the test chamber shall be recorded continuously with suitable sensors. The calibration of the sensors shall be checked regularly.

The barometric pressure at the testing laboratory shall be measured daily during the test or obtained from a closely adjacent meteorological station.

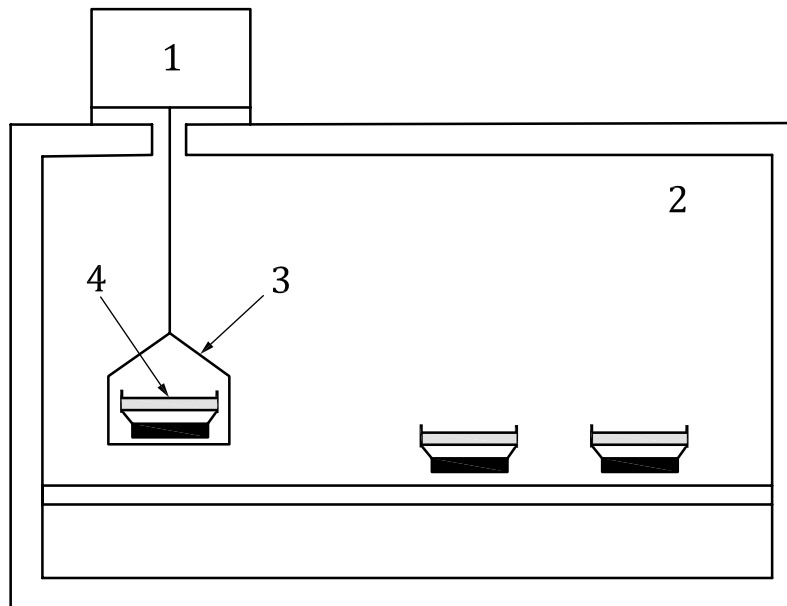

**Key**

- 1 balance
- 2 controlled environment test chamber with 'glove box' access door
- 3 suspended weighing platform
- 4 test assembly during weighing

**Figure 1 — Example of an arrangement of balance and test assemblies for weighing procedures in a chamber**

Continue weighings until five successive determinations of change in mass per weighing interval for each test specimen are constant within  $\pm 5\%$  of the mean value for this specimen (or within  $\pm 10\%$  for low permeance materials with  $\mu > 750\,000$ ) and until the change in weight of the cup assembly exceeds 100 times the repeatability of the weighing procedure.

Plot a curve of change in mass against time to facilitate recognition of the condition of constant mass change rate.

The test shall be terminated prematurely when

- a) in a dry cup test, the assembly has gained more than 1,5 g per 25 ml of desiccant in the cup, or
- b) in a wet cup test, the weight loss is half the initial mass of the solution in the cup.

## 8 Calculation and expression of results

### 8.1 Mass change rate

For each set of successive weighings of the specimens, calculate the mass change rate,  $\Delta\dot{m}_{12}$ , using [Formula \(1\)](#).

$$\Delta\dot{m}_{12} = \frac{m_2 - m_1}{t_2 - t_1} \quad (1)$$



where

- $\Delta\dot{m}_{12}$  is the change of mass per time for a single determination, in kg/s;
- $m_1$  is the mass of the test assembly at time  $t_1$ , in kg;
- $m_2$  is the mass of the test assembly at time  $t_2$ , in kg;
- $t_1$  and  $t_2$  are the successive times of weighings, in s.

Calculate  $G$ , the mean of five successive determinations of  $\Delta\dot{m}_{12}$ , for each test specimen.

The final value of  $G$  is obtained when each of the last five successive determinations of  $\Delta\dot{m}_{12}$  is within  $\pm 5\%$  of  $G$ .

## 8.2 Density of water vapour flow rate

The density of water vapour flow rate,  $g$ , is given by [Formula \(2\)](#).

$$g = \frac{G}{A} \quad (2)$$

where

- $A$  is the exposed area (arithmetic mean of the free upper and free lower surface areas) of the test specimen, in  $m^2$ .

If a cup and sealant system which includes a “masked edge” (see [Annex A](#)) has been used, values shall be corrected before being used to calculate further parameters (see [Annex F](#)).

## 8.3 Water vapour permeance

The water vapour permeance,  $W$ , is given by [Formula \(3\)](#).

$$W = \frac{G}{A \cdot \Delta p} \quad (3)$$

The value of  $\Delta p_v$  shall be calculated from the means of the measured temperatures and relative humidities over the course of the test [see [Formula \(4\)](#)].

NOTE Reference [5] contains methods on how to calculate the vapour pressure on either side of the specimen from the temperature and relative humidity for temperatures greater than 0 °C.

$$p = \phi \cdot 610,5 \cdot e^{\frac{17,269 \cdot \theta}{237,3 + \theta}} \quad (4)$$

If highly permeable materials or thin membranes with  $s_d < 0,2$  m, are being tested, the resistance of the air gap between the base of the sample and the desiccant or saturated solution shall be taken into account in the calculation of  $W$  (see [Annex G](#)).

[Table 2](#) summarizes the values of  $\Delta p$  for the five test conditions specified in [Table 1](#).

Table 2 —  $\Delta p$  values for each test condition

Set	Condition °C - % RH	$\Delta p$ Pa
A	23 - 0/50	1 404
B	23 - 0/85	2 387
C	23 - 50/93	1 207
D	38 - 0/93	6 157
E	23 - 50/100	1 404

#### 8.4 Water vapour resistance

The water vapour resistance,  $Z$ , is the reciprocal of the water vapour permeance [see [Formula \(5\)](#)].

$$Z = \frac{1}{W} \quad (5)$$

#### 8.5 Water vapour permeability

The water vapour permeability,  $\delta$ , is given by [Formula \(6\)](#).

$$\delta = W \cdot d \quad (6)$$

#### 8.6 Water vapour resistance factor

The water vapour resistance factor,  $\mu$ , is defined by [Formula \(7\)](#).

$$\mu = \frac{\delta_{\text{air}}}{\delta} \quad (7)$$

[Formula \(7\)](#), known as the Schirmer formula, is used to calculate  $\delta_a$ , using the mean barometric pressure,  $p$ , over the test [see [Formula \(8\)](#)].

$$\delta_a = \frac{0,086 p_0}{R_D \cdot T \cdot p} \left( \frac{T}{273} \right)^{1,81} \quad (8)$$

With  $R_D$ , the gas constant of water vapour  $462,10^{-6} \text{ Nm}/(\text{mg.K})$ .

Values of  $\delta_a$  at 23 °C are shown in [Figure 2](#).

The water vapour permeability of air and the material may be assumed to vary equally with the barometric pressure. The factor  $\mu$  can therefore be considered independent of barometric pressure. When calculating the value of  $\mu$  using the expression in [Formula \(9\)](#).

$$\mu = \frac{\Delta p \cdot \delta_{\text{air}}}{g \cdot d} \quad (9)$$

the value of  $\delta_a$  shall correspond to the actual barometric pressure.

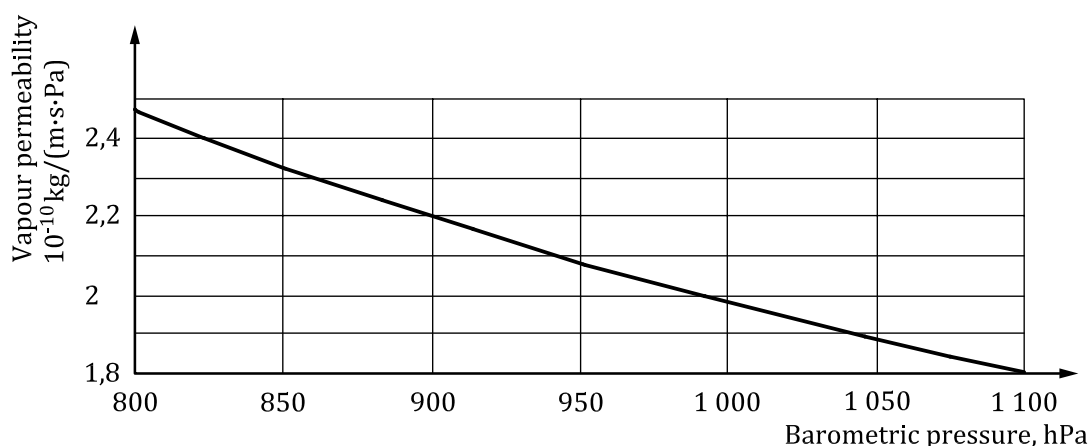

Figure 2 — Water vapour permeability of air as a function of barometric pressure at 23°C

## 8.7 Water vapour diffusion-equivalent air layer thickness

The water vapour diffusion-equivalent air layer thickness,  $s_d$ , is given by either [Formula \(10\)](#) or [Formula \(11\)](#).

$$s_d = \mu \cdot d \quad (10)$$

$$s_d = \delta_a \cdot Z \quad (11)$$

## 9 Accuracy of measurement

### 9.1 General

Clause 9 and [Annex I](#) discuss the factors that affect the accuracy of the result and give guidance on how to improve it, if necessary.

NOTE A number of “round-robin” intercomparisons of measurements by different laboratories have been carried out (see References [\[8\]](#), [\[11\]](#) and [\[14\]](#) for discussion of the results).

A number of factors affect the accuracy of the measured values.

### 9.2 Specimen area

The diameter of a circular test cup or the side of a square test cup shall be measured to an accuracy of  $\pm 0,5$  mm, giving a possible error in the area of a specimen of the minimum size specified in [6.2.2](#) (i.e.  $0,05 \text{ m}^2$ ) of  $\pm 0,5$  %. This error will be less with larger specimens. For certain cup types, it will be necessary to correct for the effect of a masked edge as specified in [Annex F](#).

### 9.3 Specimen thickness

If the permeance or resistance of a complete product is being measured, the accuracy is not affected by the thickness. However, if the permeability of a material is needed, the accuracy with which the specimen thickness can be measured will directly effect the accuracy of the result. The thickness of a rigid specimen can be measured to better than 0,5 % with a micrometer.

NOTE The accuracy will be lower in the case of loose fill and similar materials.

## 9.4 Sealants

If an appropriate sealant is installed as specified in the Annexes, errors caused by leakage can be much less than those from other sources. A faulty seal will result in a much higher flow rate through one of the test assemblies. That result shall be rejected before averages are taken over the samples.

Close attention should be given to the method of applying sealing and laboratory staff should be trained accordingly. It is recommended that initial tests are carried out with an impermeable metal specimen to test that the resultant vapour flow rate is zero.

## 9.5 Weighing precision

The influence of weighing uncertainty on the accuracy of the results depends on the size of the specimen and the time interval between successive weighings.

NOTE Information about the weighing repeatability needed to achieve a desired accuracy in relation to the specimen size and weighing interval is given in [Annex I](#).

## 9.6 Control of environmental conditions

The vapour pressure difference between the test cup and the environmental chamber is the driving potential for the whole test. The accuracy with which this difference is known consequently determines the accuracy of the measured values.

The vapour pressure within the cup is determined by the desiccant or saturated solution used. A suitable desiccant should give effectively zero vapour pressure. The relative humidity over saturated solutions is quoted to the nearest  $\pm 0,5$  % relative humidity in tables and this can be achieved if care is taken in their preparation.

The test conditions in [Table 1](#) will result in a variation in vapour pressure difference across the test specimen of  $\pm 10$  % of the set point value.

Conditions within the environmental chamber shall be carefully monitored with accurately calibrated instruments to determine an accurate mean vapour pressure over the test.

NOTE Considerable care is needed in the measurement of conditions within the environmental chamber in order to obtain accurate permeability data.

## 9.7 Variations in barometric pressure during test

For products with low water vapour transmission rates, especially thin flexible membranes, large day-to-day pressure variations may affect the results. Account shall be taken of the buoyancy effect either by including the change of weight of a “dummy” specimen, without an aqueous saturated solution or desiccant, and then subtracting the change in weight of the “dummy” specimen from the change in weight of the test specimen, or by extending the test over several weeks and selecting the measurements taken on the days with a similar barometric pressure for further analysis.

## 10 Test report

The test report shall include the following:

- a) a reference to this International Standard, i.e. (ISO 12572);
- b) product identification;
  - 1) product name, factory, manufacturer or supplier;
  - 2) type of product;
  - 3) production code number or similar identifier;

- 4) the form in which the product arrived at the laboratory, including facings, if any;
  - 5) the method of preparation of the specimen, including slicing where done, and details of any curing process, where necessary;
  - 6) other details of the product e.g. nominal thickness or nominal density;
- c) test procedure;
- 1) the mean air pressure and the temperature and relative humidity gradients across the specimen and the range of any deviations from the mean;
  - 2) test configuration used;
  - 3) conditioning of the specimen carried out;
  - 4) any deviation from this standard procedure and any incidents which may have influenced the results;
  - 5) the date of the test;
  - 6) information concerning the operator and the apparatus used, (it is mandatory that the information is available at the laboratory, but it should be included only if requested);
- d) results;
- 1) the water vapour transmission property (water vapour transmission rate, permeance, permeability or water vapour resistance) including the direction of the vapour flow relative to the facings for materials with two different facings, for which the results have been calculated;
  - 2) all corrections applied for a masked edge or variations in barometric pressure;
  - 3) the individual test results;
  - 4) the arithmetic mean of the individual test results.

## Annex A (normative)

### Methods suitable for self-supporting materials

#### A.1 General

Annex A applies to all materials which can be made into self-supporting specimens. That includes insulating materials and materials such as rendering or mortars which are made up and cured before test. For thermal insulation materials, if it is intended to measure the permeability of the core material, all skins and facings shall be removed and the test specimens shall have a thickness of at least 20 mm.

#### A.2 Specimen preparation

Specimens of appropriate size shall be cut from board or masonry materials. Care shall be taken to ensure the vapour transfer properties of surfaces cut normal to the direction of moisture flow are not affected by the cutting process, for example, a skin may form on plastic foams during cutting.

Where materials such as mortars or renders have to be made up for testing, specimens of the required thickness, somewhat larger than the dimensions of the test cup shall be prepared and cured for 28 days before testing. Cement-based mortars shall be covered with a vapour barrier for three days. After this moist curing, the specimens shall be stored for the remaining 25 days at a temperature of  $(23 \pm 5) ^\circ\text{C}$  and relative humidity of  $(50 \pm 5) \%$ . The specimens shall then be cut to the size of the test cup.

#### A.3 Cup design

Examples of suitable cups are shown in [Figure A.1](#).

A template is shown in [Figures A.1 a\)](#) and [b\)](#). It is essential that these are used with these types of cups to provide a well-defined upper specimen surface area free of sealant. If the cups shown in [Figures A.1 a\)](#) and [b\)](#) are used, the specimen will have a "masked edge". It is necessary to correct for this in the calculation of the vapour flow rate (see [Annex F](#)).

#### A.4 Sealants

Sealants should be easily handled, remain flexible and not crack over a long test and have good adhesion to the specimen. Molten sealants may penetrate far enough into porous materials to introduce errors into the effective area under test. The edge of these samples should be sealed with tape or an epoxy resin before sealing.

NOTE Examples of suitable sealants are the following: a) a mixture of 90 % micro crystalline wax and a 10 % of a plasticizer (e.g. a low molecular weight polyisobutylene); b) a mixture of 60 % micro crystalline wax with 40 % refined crystalline paraffin. See the Bibliography for further information.

#### A.5 Calculation and expression of results

The areas of the top and bottom of the specimen  $A_1$  and  $A_2$  are shown in [Figure A.1](#). The procedures specified in [Clause 8](#) shall then be followed.

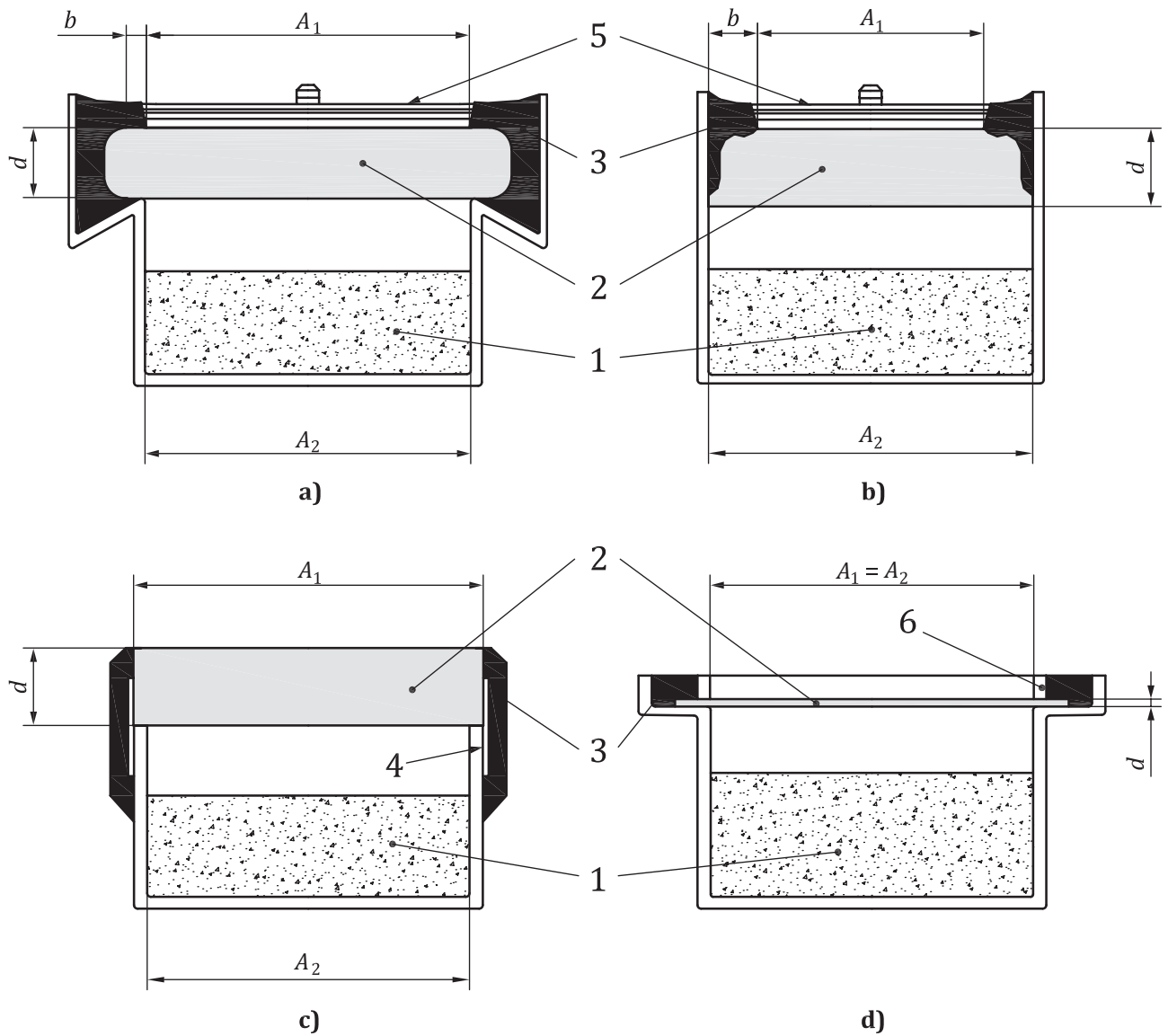

**Key**

- 1 desiccant/aqueous saturated salt solution
- 2 test specimen
- 3 sealant
- 4 tape
- 5 template
- 6 limiting ring

- $A_1$  upper exposed area
- $A_2$  lower exposed area
- $b$  width of the masked edge
- $d$  thickness of the test specimen

NOTE The mean exposed area  $A = (A_1 + A_2)/2$ .

**Figure A.1 — Examples of test assemblies**

## Annex B (normative)

### Methods suitable for loose fills

#### B.1 General

Annex B covers all materials that are used in powder or granular form, from which it is not possible to make a self-supporting test specimen.

#### B.2 Sample selection

If the material to be tested contains a range of particle sizes, the samples tested shall be representative of the whole material in use.

#### B.3 Cup design

As shown in [Figure B.1](#), the specimen is supported on a wire mesh or permeable membrane placed over the mouth of the cup. If a mesh is used, the open areas shall be as large as possible while completely supporting the specimen during the whole course of the test. If a membrane or grid with an open area small enough to affect the flow of vapour is used, the permeability of these shall also be tested without the fill in place. The specimen should have a thickness of at least 100 mm, to limit the uncertainties that will result from the difficulty of accurately measuring the thickness of this type of material. As it is not possible to seal this type of material, it shall overlap the edge of the test cup by at least 20 mm.

NOTE As the permeability will be high, the errors that result from leakage at the edges will be of little consequence.

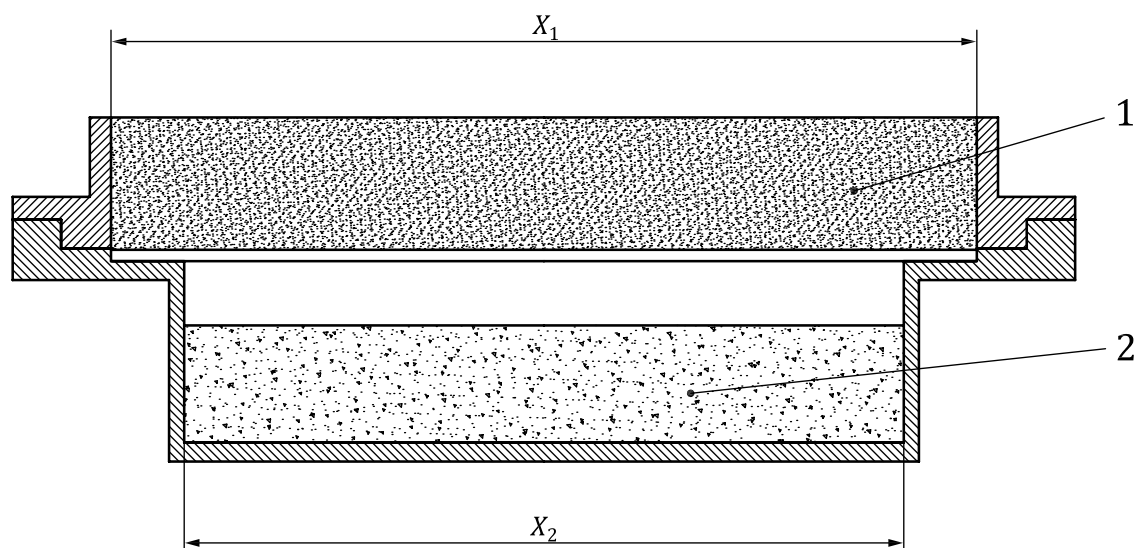

#### Key

- 1 test specimen
- 2 grid or membrane

Figure B.1 — Suitable cup for loose fill



#### B.4 Calculation and expression of results

If an open mesh grid is used to support the specimen, the results shall be calculated according to [Clause 8](#), with the effective area taken as the mean of the areas calculated from the dimensions  $X_1$  and  $X_2$  indicated in [Figure B.1](#). If a membrane is used, the vapour resistance of the membrane alone,  $Z_m$ , and the membrane and specimen,  $Z_t$ , shall be calculated as in [8.1](#) to [8.4](#). The vapour resistance of the specimen alone is then given by  $Z_s = Z_t - Z_m$ .

$Z_s$  can then be used to calculate the other parameters in [Clause 8](#).

## Annex C (normative)

### Methods suitable for membranes and foils

#### C.1 General

Annex C covers all flexible membranes, foils and sheet materials.

#### C.2 Specimen preparation

Specimens shall be cut to an appropriate size for the cup to be used.

#### C.3 Cup design

A recommended cup design using mechanical sealing is shown in [Figure C.1](#). Sealing rings of an appropriate material can be included to improve the seal.

#### C.4 Calculation and expression of results

The formulae in [Clause 8](#) shall be used to calculate the results of the test. For many materials covered by Annex C, especially thin foils and membranes, it is not usual to measure the thickness and calculate the permeability. The permeance or resistance of the actual product in use is quoted.

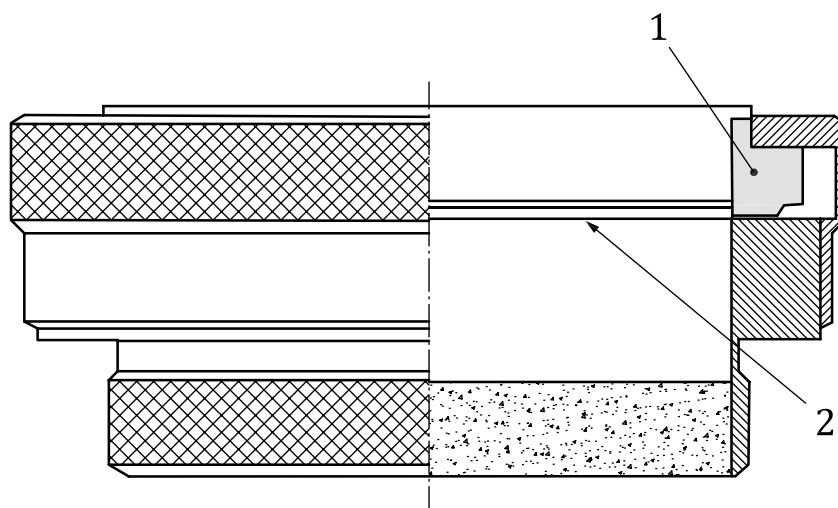

#### Key

- 1 sealing ring
- 2 specimen

Figure C.1 — Cup suitable for membranes and foils

## Annex D (normative)

### Methods suitable for mastics and sealants

#### D.1 General

Annex D covers materials, such as mastics or sealants that are applied as highly viscous fluids, which set to a non-rigid flexible matrix.

#### D.2 Specimen preparation

A permeable membrane, that does not react physically or chemically with the test material, shall be spread on a flat surface. The test material is then spread upon it to slightly more than the required thickness. Before hardening, a top plate, if necessary with an intermediate film to prevent sticking, is placed on top to achieve the required test thickness. After the specimens have cured, the top plate and film are removed and the specimen cut to the size of the test cup.

It might be difficult to achieve a uniform coating of some adhesives or sealants. In this case, a narrow slot of defined dimensions cut in a self-supporting material with a known low permeance,  $W_s$ , is filled with the sealant or mastic (see [Figure D.1](#)). This shall be tested as specified in [Annex A](#).

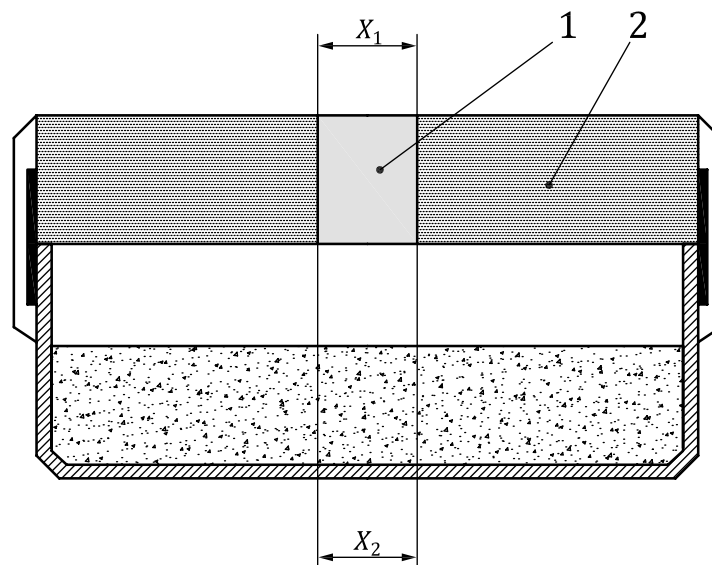

#### Key

- 1 mastic sealant in slot
- 2 low permeability material

**Figure D.1 — Example of a cup suitable for mastics and sealants**

#### D.3 Cup design

If the specimen is supported by a membrane, a recommended cup design is shown in [Figure B.1](#). If the specimen is filling a joint, a recommended cup is shown in [Figure D.1](#).

#### D.4 Calculation and expression of results

If a membrane has been used, the vapour resistance of the membrane alone,  $Z_m$ , and the membrane and specimen,  $Z_t$ , shall be calculated as in [8.1](#) to [8.4](#). The vapour resistance of the specimen alone is then given by:

$$Z_s = Z_t - Z_m \quad (\text{D.1})$$

$Z_s$  can then be used to calculate the other parameters as in [Clause 8](#).

If the method including a filled joint, shown in [Figure D.1](#), has been used, the rate at which the weight of the cup changes is:

$$G = G_j + G_s \quad (\text{D.2})$$

where  $G_j$  is due to the joint and  $G_s$  is due to the remaining specimen. If the respective areas are  $A_j$  and  $A_s$ , then

$$G_s = W_s \cdot A_s \cdot \Delta p \quad (\text{D.3})$$

and

$$g_j = G_j/A_j \quad (\text{D.4})$$

Therefore,

$$g_j = (G - W_s \cdot A_s \cdot \Delta p)/A_j \quad (\text{D.5})$$

The remaining parameters as specified in [8.3](#) to [8.7](#) can then be calculated from  $g_j$  and  $A_j$ .

## Annex E (normative)

### Methods suitable for paint, varnishes, etc.

#### E.1 General

Annex E covers any material that is normally applied wet, by brushing or spraying, and which forms a thin film upon drying.

#### E.2 Specimen preparation

A permeable membrane or self-supporting material, selected to be unaffected, chemically or physically, by the paint film, shall be tested as specified in [Annex A](#) or [C](#). The material to be tested shall then be applied, in a manner and thickness similar to its normal use, to completely cover the membrane or support and the test repeated.

#### E.3 Calculation and expression of results

The vapour resistance of the membrane or support alone,  $Z_m$ , and the membrane and paint film,  $Z_t$ , shall be calculated as in [8.1](#) to [8.4](#). The vapour resistance of the film alone is then given by:

$$Z_f = Z_t - Z_m \quad (\text{E.1})$$

$Z_f$  can then be used to calculate the permeance of the film.

As the thickness of films is too small to be measured by conventional means, it is not usual to refer to their permeability. The permeance or resistance shall be quoted, with details of the application method, number of coats, etc.

## Annex F (normative)

### Correction for the effect of a masked edge of a specimen

In some types of cup assemblies, the edge of the specimen overlaps the edge of the cup (see, for example, [Figure A.1](#)). As this “masked edge” is a route for two dimensional flow of vapour, the total flow through the specimen is greater than that through the exposed area, leading to an overestimate of the permeance. The size of this effect shall be assessed from

$$\frac{g_{me}}{g} = 1 + \frac{4 \cdot d}{\pi \cdot S} \cdot \ln \left( \frac{2}{1 + \exp(-2 \cdot \pi \cdot b / d)} \right) \quad (\text{F.1})$$

where

$g_{me}$  is the vapour transmission rate with masked edge, in  $\text{kg}/(\text{m}^2 \cdot \text{s})$ ;

$g$  is the vapour transmission rate ignoring the masked edge, in  $\text{kg}/(\text{m}^2 \cdot \text{s})$ ;

$d$  is the thickness of the specimen, in m;

$b$  is the width of the masked edge, in m (see [Figure A.1](#));

$S$  is the hydraulic diameter, in m;

(four times the test area divided by the perimeter).

The values of  $g_{me}/g$  calculated from [Formula \(F.1\)](#) depend on two ratios:  $b/d$ , the size of the masked edge divided by the thickness of the specimen and  $d/S$ , the thickness divided by the typical size of the specimen. [Figure F.1](#) shows values of  $g_{me}/g$  as a function of these two ratios. Values of  $g_{me}$  measured using a cup with a masked edge shall be corrected by dividing by the appropriate value of  $g_{me}/g$ , either calculated from [Formula \(F.1\)](#) or taken from [Figure F.1](#), before the permeance is calculated.

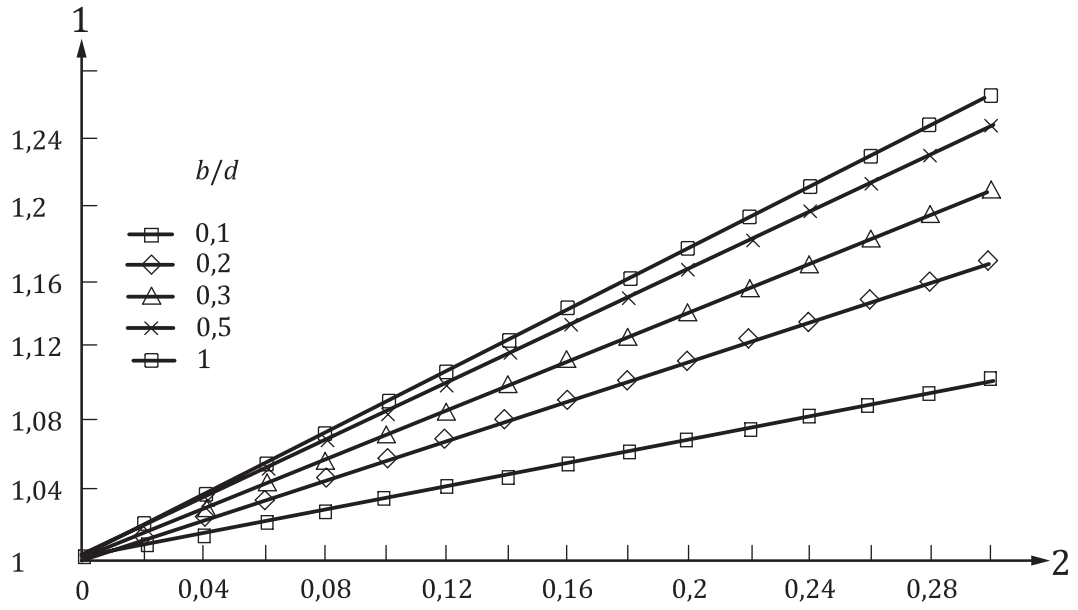

**Key**

- 1  $g_{me}/g$
- 2 specimen thickness divided by hydraulic diameter ( $d/S$ )

**Figure F.1 — Size of masked edge correction**

## Annex G (normative)

### Correction for resistance of air layers

#### G.1 Air layer in the test cup

The layer of air in the test cup between the base of the specimen and the desiccant or saturated salt solution has some resistance to the flow of vapour. For most materials, this is much smaller than the material resistance, however, it can introduce a significant error in the case of very permeable materials or thin membranes.

If the water vapour diffusion-equivalent air layer thickness,  $s_d$  (see 8.7), is less than 0,2 m, the measured permeance calculated in [Formula \(3\)](#) shall be corrected by [Formula \(G.1\)](#):

$$W_c = \frac{1}{\frac{A \cdot \Delta p_v}{G} - \frac{d_a}{\delta_a}} \quad (\text{G.1})$$

where

$d_a$  is the thickness of the air layer;

$\delta_a$  is the water vapour permeability of air from [Formula \(7\)](#) or [Figure 2](#).

The value of  $W_c$  is then used to calculate the remaining parameters specified in [8.4](#) to [8.7](#).

NOTE The resistance of the air layer in the cup,  $Z_c = 1/W_c$ , can be found using the method specified in [Annex H](#).

#### G.2 Air layer above the test cup

To ensure that the resistance of the air layer above the test cup is negligible, when very permeable materials or thin membranes are tested, the air in test chamber shall be stirred and the test assemblies arranged within the chamber to ensure that the air velocity above each specimen is at least 2 m/s.

NOTE Use of a test assembly without a high rim will reduce the risk of a stagnant air layer forming above the specimen.



## Annex H (normative)

### Method for calculating the water vapour resistance of the air layer in the cup

The water-vapour resistance of the air layer in the cup,  $Z_c$ , which is significant for low resistance specimens, discussed in [Clause 8](#), can be calculated by the following method. Firstly, using the procedures specified in [Clause 7](#) and the formulae specified in [Clause 8](#), one specimen is used to determine water-vapour resistance,  $Z_1$ , and then a second specimen, consisting of two overlaid sheets each equal in thickness to the specimen, is used to determine water vapour resistance,  $Z_2$ , in the same manner.

While,  $Z_1$  and  $Z_2$  are expressed by [Formulae \(H.1\)](#) and [\(H.2\)](#):

$$Z_1 = Z_p + Z_c \quad (\text{H.1})$$

$$Z_2 = 2Z_p + Z_c \quad (\text{H.2})$$

Therefore, the water-vapour surface resistance,  $Z_c$ , can be calculated from [Formula \(H.3\)](#).

$$Z_c = 2Z_1 - Z_2 \quad (\text{H.3})$$

## Annex I (informative)

### Weighing repeatability, weighing interval and specimen size needed to achieve desired accuracy

The following symbols are used in Annex I.

Symbol	Quantity	Unit
$m_t$	mass of test assembly at time, $t$	kg
$t_I$	interval between weighings	s
$m_p$	repeatability error of balance used for weighing	kg
$X$	desired accuracy of result	—

The mass transferred through a test specimen between weighings once equilibrium has been established is given by [Formula \(I.1\)](#).

$$m_2 - m_1 = \frac{\delta_a \cdot A \cdot \Delta p_v \cdot t_I}{\mu \cdot d} \quad (I.1)$$

As the permeability depends on the change in weight between successive weighings, the maximum repeatability error on each weighing to achieve  $X$  % accuracy in  $m_2 - m_1$  is  $(m_2 - m_1) \cdot X/200$ . The necessary weighing repeatability is therefore characterized by [Formula \(I.2\)](#).

$$m_r = \frac{\delta_a \cdot A \cdot \Delta p_v \cdot t_I \cdot X}{200 \cdot \mu \cdot d} \quad (I.2)$$

If the best available balance cannot weigh with sufficient repeatability to provide the desired accuracy, the necessary repeatability may be relaxed by increasing either the area of the test specimen or the interval between weighings.

If  $m_r$  is the repeatability of the best available balance, the area can be increased [see [Formula \(I.3\)](#)]

$$A = \frac{200 \cdot m_p \cdot \mu \cdot d}{\delta_a \cdot \Delta p_v \cdot t_I \cdot X} \quad (I.3)$$

or the weighing interval [see [Formula \(I.4\)](#)]

$$t_I = \frac{200 \cdot m_p \cdot \mu \cdot d}{\delta_a \cdot \Delta p_v \cdot A \cdot X} \quad (I.4)$$

## Annex J (informative)

### Conversion table for water vapour transmission units

Name according to 3.2	Units according to 3.2 (A)	Conversion factor (C)	Other name	Other unit (B)
density of water vapour flow rate	kg/(m <sup>2</sup> ·s)	3,60 × 10 <sup>9</sup>	water vapour transmission rate	mg·/(m <sup>2</sup> ·h)
water vapour permeance	kg/(m <sup>2</sup> ·s·Pa)	3,60 × 10 <sup>9</sup>	water vapour permeance	mg·/(m <sup>2</sup> ·h·Pa)
water vapour resistance	m <sup>2</sup> ·s·Pa/kg	2,778 × 10 <sup>-10</sup>	water vapour resistance	m <sup>2</sup> ·h·Pa/mg
water vapour permeability	kg/(m·s·Pa)	3,60 × 10 <sup>9</sup>	water vapour permeability	mg/(m·h·Pa)
water vapour resistance factor	—	—	water vapour diffusion resistance factor	—
water vapour flow rate	kg/s	3,60 × 10 <sup>9</sup>	water vapour flow rate	mg/h

To convert from units corresponding to ISO 9346 to other units, multiply by C and to convert from other units to units according to ISO 9346, divide by C.

$$\mathbf{B = A \cdot C \text{ or } A = B/C}$$

EXAMPLE 1  $W$ :  $1 \text{ mg}/(\text{m}^2 \cdot \text{h} \cdot \text{Pa}) = 2,778 \times 10^{-10} \text{ kg}/(\text{m}^2 \cdot \text{s} \cdot \text{Pa})$

EXAMPLE 2  $\delta$ :  $1 \text{ kg}/(\text{m} \cdot \text{s} \cdot \text{Pa}) = \frac{1}{2,778 \times 10^{-10}} \text{ mg}/(\text{m} \cdot \text{h} \cdot \text{Pa})$

## Bibliography

- [1] ISO 9346, *Hygrothermal performance of building materials and products — Physical quantities for mass transfer — Vocabulary*
- [2] ISO 12570, *Hygrothermal performance of building materials and products — Determination of moisture content by drying at elevated temperature*
- [3] ISO 12571, *Hygrothermal performance of building materials and products — Determination of hygroscopic sorption properties*
- [4] ISO 15148, *Hygrothermal performance of building materials and products — Determination of water absorption coefficient by partial immersion*
- [5] BS 5250:2011, *British Standard Code of practice for Control of condensation in buildings, British Standards Institution 2011*
- [6] ASTM STANDARD TEST METHODS FOR WATER VAPOUR TRANSMISSION OF MATERIALS. ASTM E96-80. Annual Book of ASTM Standards, section 4. 1989, **4** pp. 634–641
- [7] BURCH D.M., THOMAS W.C., FANNEY A.H. Water vapour permeability measurements of common building materials. ASHRAE Transactions, **Vol. 98**, Part 2 1992
- [8] FANNEY A.H., THOMAS W.C., BURCH D.M., MATHENA L.R. Measurements of moisture diffusion in building materials. ASHRAE Transactions. 1991, **97** (part 2) pp. 99–113
- [9] GALBRAITH GH, McCLEAN RC, TAO Zhi *Intercomparison on measurement of water vapour permeability*; Final Report of EC Contract 3366/1/0/151/90/1-BCR-UK(30) January 1992
- [10] GALBRAITH G.H., McCLEAN R.C., TAO Z. Vapour permeability: suitability and consistency of current test procedures. Build. Serv. Eng. Res. Tech. 1993, **14** (2) pp. 67–70
- [11] JOY FA, & WILSON AG *Standardisation of the dish method for measuring water vapour transmission*. National Research Council of Canada 31 1966
- [12] KRUS M, & KIESSL K *Ist der Diffusionswiderstand von Baustoffen wirklich feuchteabhängig?* IBP-Mitteilung 18 (1991), Nr 208
- [13] LIERSCH KW, & JASPERS D *Eine einfache Methode zur Bestimmung realitätsnaher  $s_d$ -Werte von extrem diffusionsoffenen Unterspannbahnen in Anlehnung an DIN 52615*. Wksb 41 (1996), h. 37, p31-33
- [14] McCLEAN R.C., GALBRAITH G.H., SANDERS C.H. Moisture transmission testing of building materials and the presentation of vapour permeability values. Building Research and Practice No. 1990, **2** pp. 82–91
- [15] TRESCHEL H.R., & BOMBERG M. eds. Water vapour transmission through building materials and systems: Mechanisms and Measurements. ASTM STP 1039. ASTM, Philadelphia, 1989







# British Standards Institution (BSI)

BSI is the national body responsible for preparing British Standards and other standards-related publications, information and services.

BSI is incorporated by Royal Charter. British Standards and other standardization products are published by BSI Standards Limited.

## About us

We bring together business, industry, government, consumers, innovators and others to shape their combined experience and expertise into standards-based solutions.

The knowledge embodied in our standards has been carefully assembled in a dependable format and refined through our open consultation process. Organizations of all sizes and across all sectors choose standards to help them achieve their goals.

## Information on standards

We can provide you with the knowledge that your organization needs to succeed. Find out more about British Standards by visiting our website at [bsigroup.com/standards](http://bsigroup.com/standards) or contacting our Customer Services team or Knowledge Centre.

## Buying standards

You can buy and download PDF versions of BSI publications, including British and adopted European and international standards, through our website at [bsigroup.com/shop](http://bsigroup.com/shop), where hard copies can also be purchased.

If you need international and foreign standards from other Standards Development Organizations, hard copies can be ordered from our Customer Services team.

## Copyright in BSI publications

All the content in BSI publications, including British Standards, is the property of and copyrighted by BSI or some person or entity that owns copyright in the information used (such as the international standardization bodies) and has formally licensed such information to BSI for commercial publication and use.

Save for the provisions below, you may not transfer, share or disseminate any portion of the standard to any other person. You may not adapt, distribute, commercially exploit, or publicly display the standard or any portion thereof in any manner whatsoever without BSI's prior written consent.

## Storing and using standards

Standards purchased in soft copy format:

- A British Standard purchased in soft copy format is licensed to a sole named user for personal or internal company use only.
- The standard may be stored on more than 1 device provided that it is accessible by the sole named user only and that only 1 copy is accessed at any one time.
- A single paper copy may be printed for personal or internal company use only.

Standards purchased in hard copy format:

- A British Standard purchased in hard copy format is for personal or internal company use only.
- It may not be further reproduced – in any format – to create an additional copy. This includes scanning of the document.

If you need more than 1 copy of the document, or if you wish to share the document on an internal network, you can save money by choosing a subscription product (see 'Subscriptions').

## Reproducing extracts

For permission to reproduce content from BSI publications contact the BSI Copyright & Licensing team.

## Subscriptions

Our range of subscription services are designed to make using standards easier for you. For further information on our subscription products go to [bsigroup.com/subscriptions](http://bsigroup.com/subscriptions).

With **British Standards Online (BSOL)** you'll have instant access to over 55,000 British and adopted European and international standards from your desktop. It's available 24/7 and is refreshed daily so you'll always be up to date.

You can keep in touch with standards developments and receive substantial discounts on the purchase price of standards, both in single copy and subscription format, by becoming a **BSI Subscribing Member**.

**PLUS** is an updating service exclusive to BSI Subscribing Members. You will automatically receive the latest hard copy of your standards when they're revised or replaced.

To find out more about becoming a BSI Subscribing Member and the benefits of membership, please visit [bsigroup.com/shop](http://bsigroup.com/shop).

With a **Multi-User Network Licence (MUNL)** you are able to host standards publications on your intranet. Licences can cover as few or as many users as you wish. With updates supplied as soon as they're available, you can be sure your documentation is current. For further information, email [subscriptions@bsigroup.com](mailto:subscriptions@bsigroup.com).

## Revisions

Our British Standards and other publications are updated by amendment or revision.

We continually improve the quality of our products and services to benefit your business. If you find an inaccuracy or ambiguity within a British Standard or other BSI publication please inform the Knowledge Centre.

## Useful Contacts

### Customer Services

**Tel:** +44 345 086 9001

**Email (orders):** [orders@bsigroup.com](mailto:orders@bsigroup.com)

**Email (enquiries):** [cservices@bsigroup.com](mailto:cservices@bsigroup.com)

### Subscriptions

**Tel:** +44 345 086 9001

**Email:** [subscriptions@bsigroup.com](mailto:subscriptions@bsigroup.com)

### Knowledge Centre

**Tel:** +44 20 8996 7004

**Email:** [knowledgecentre@bsigroup.com](mailto:knowledgecentre@bsigroup.com)

### Copyright & Licensing

**Tel:** +44 20 8996 7070

**Email:** [copyright@bsigroup.com](mailto:copyright@bsigroup.com)

### BSI Group Headquarters

389 Chiswick High Road London W4 4AL UK