

Thermal insulation for building equipment and industrial installations — Calculation rules (ISO 12241:2008)

ICS 27.220; 91.120.10; 91.140.01

National foreword

This British Standard is the UK implementation of EN ISO 12241:2008. It is identical to ISO 12241:2008. It supersedes BS EN ISO 12241:1998 which is withdrawn.

The UK participation in its preparation was entrusted to Technical Committee B/540, Energy performance of materials components and buildings.

A list of organizations represented on this committee can be obtained on request to its secretary.

This publication does not purport to include all the necessary provisions of a contract. Users are responsible for its correct application.

Compliance with a British Standard cannot confer immunity from legal obligations.

This British Standard was published under the authority of the Standards Policy and Strategy Committee on 31 May 2009

© BSI 2009

ISBN 978 0 580 56728 5

Amendments/corrigenda issued since publication

Date	Comments

English Version

Thermal insulation for building equipment and industrial installations - Calculation rules (ISO 12241:2008)

Isolation thermique des équipements de bâtiments et des installations industrielles - Méthodes de calcul (ISO 12241:2008)

Wärmedämmung an haus- und betriebstechnischen Anlagen - Berechnungsregeln (ISO 12241:2008)

This European Standard was approved by CEN on 1 May 2008.

CEN members are bound to comply with the CEN/CENELEC Internal Regulations which stipulate the conditions for giving this European Standard the status of a national standard without any alteration. Up-to-date lists and bibliographical references concerning such national standards may be obtained on application to the CEN Management Centre or to any CEN member.

This European Standard exists in three official versions (English, French, German). A version in any other language made by translation under the responsibility of a CEN member into its own language and notified to the CEN Management Centre has the same status as the official versions.

CEN members are the national standards bodies of Austria, Belgium, Bulgaria, Cyprus, Czech Republic, Denmark, Estonia, Finland, France, Germany, Greece, Hungary, Iceland, Ireland, Italy, Latvia, Lithuania, Luxembourg, Malta, Netherlands, Norway, Poland, Portugal, Romania, Slovakia, Slovenia, Spain, Sweden, Switzerland and United Kingdom.



EUROPEAN COMMITTEE FOR STANDARDIZATION
COMITÉ EUROPÉEN DE NORMALISATION
EUROPÄISCHES KOMITEE FÜR NORMUNG

Management Centre: rue de Stassart, 36 B-1050 Brussels

Foreword

This document (EN ISO 12241:2008) has been prepared by Technical Committee ISO/TC 163 "Thermal performance and energy use in the built environment" in collaboration with Technical Committee CEN/TC 89 "Thermal performance of buildings and building components" the secretariat of which is held by SIS.

This European Standard shall be given the status of a national standard, either by publication of an identical text or by endorsement, at the latest by December 2008, and conflicting national standards shall be withdrawn at the latest by December 2008.

Attention is drawn to the possibility that some of the elements of this document may be the subject of patent rights. CEN [and/or CENELEC] shall not be held responsible for identifying any or all such patent rights.

This document supersedes EN ISO 12241:1998.

According to the CEN/CENELEC Internal Regulations, the national standards organizations of the following countries are bound to implement this European Standard: Austria, Belgium, Bulgaria, Cyprus, Czech Republic, Denmark, Estonia, Finland, France, Germany, Greece, Hungary, Iceland, Ireland, Italy, Latvia, Lithuania, Luxembourg, Malta, Netherlands, Norway, Poland, Portugal, Romania, Slovakia, Slovenia, Spain, Sweden, Switzerland and the United Kingdom.

Endorsement notice

The text of ISO 12241:2008 has been approved by CEN as a EN ISO 12241:2008 without any modification.

Contents

Page

Foreword.....	iv
Introduction	v
1 Scope	1
2 Normative references	1
3 Terms, definitions and symbols	1
3.1 Terms and definitions.....	1
3.2 Definition of symbols	2
3.3 Subscripts	3
4 Calculation methods for heat transfer.....	3
4.1 Fundamental equations for heat transfer.....	3
4.2 Surface temperature	14
4.3 Prevention of surface condensation.....	17
4.4 Determination of total heat flow rate for plane walls, pipes and spheres	20
5 Calculation of the temperature change in pipes, vessels and containers.....	21
5.1 Longitudinal temperature change in a pipe	21
5.2 Temperature change and cooling times in pipes, vessels and containers	22
6 Calculation of cooling and freezing times of stationary liquids	22
6.1 Calculation of the cooling time for a given thickness of insulation to prevent the freezing of water in a pipe.....	22
6.2 Calculation of the freezing time of water in a pipe	24
7 Determination of the influence of thermal bridges	25
7.1 General.....	25
7.2 Calculation of correction terms for plane surfaces	26
7.3 Calculation of correction terms for pipes	26
8 Underground pipelines.....	27
8.1 General.....	27
8.2 Calculation of heat loss (single line) without channels.....	27
8.3 Other cases	29
Annex A (normative) Thermal bridges in pipe insulation	30
Annex B (informative) Projecting thermal bridges of roughly constant cross-section	33
Annex C (informative) Examples	38
Bibliography	45

Foreword

ISO (the International Organization for Standardization) is a worldwide federation of national standards bodies (ISO member bodies). The work of preparing International Standards is normally carried out through ISO technical committees. Each member body interested in a subject for which a technical committee has been established has the right to be represented on that committee. International organizations, governmental and non-governmental, in liaison with ISO, also take part in the work. ISO collaborates closely with the International Electrotechnical Commission (IEC) on all matters of electrotechnical standardization.

International Standards are drafted in accordance with the rules given in the ISO/IEC Directives, Part 2.

The main task of technical committees is to prepare International Standards. Draft International Standards adopted by the technical committees are circulated to the member bodies for voting. Publication as an International Standard requires approval by at least 75 % of the member bodies casting a vote.

Attention is drawn to the possibility that some of the elements of this document may be the subject of patent rights. ISO shall not be held responsible for identifying any or all such patent rights.

ISO 12241 was prepared by Technical Committee ISO/TC 163, *Thermal performance and energy use in the built environment*, Subcommittee SC 2, *Calculation methods*.

This second edition cancels and replaces the first edition (ISO 12241:1998), which has been technically revised, including methods to determine the correction terms for thermal transmittance and linear thermal transmittance for pipes that are added to the calculated thermal transmittance to obtain the total thermal transmittance to calculate the total heat losses for an industrial installation.

Introduction

Methods relating to conduction are direct mathematical derivations from Fourier's law of heat conduction, so international consensus is purely a matter of mathematical verification. No significant difference in the equations used in the member countries exists. For convection and radiation, however, there are no methods in practical use that are mathematically traceable to Newton's law of cooling or the Stefan-Boltzman law of thermal radiation, without some empirical element. For convection in particular, many different equations have been developed, based on laboratory data. Different equations have become popular in different countries, and no exact means are available to select between these equations.

Within the limitations given, these methods can be applied to most types of industrial, thermal-insulation, heat-transfer problems.

These methods do not take into account the permeation of air or the transmittance of thermal radiation through transparent media.

The equations in these methods require for their solution that some system variables be known, given, assumed or measured. In all cases, the accuracy of the results depends on the accuracy of the input variables. This International Standard contains no guidelines for accurate measurement of any of the variables. However, it does contain guides that have proven satisfactory for estimating some of the variables for many industrial thermal systems.

It should be noted that the steady-state calculations are dependent on boundary conditions. Often a solution at one set of boundary conditions is not sufficient to characterize a thermal system that operates in a changing thermal environment (process equipment operating year-round, outdoors, for example). In such cases, it is necessary to use local weather data based on yearly averages or yearly extremes of the weather variables (depending on the nature of the particular calculation) for the calculations in this International Standard.

In particular, the user should not infer from the methods of this International Standard that either insulation quality or avoidance of dew formation can be reliably assured based on minimal, simple measurements and application of the basic calculation methods given here. For most industrial heat flow surfaces, there is no isothermal state (no one, homogeneous temperature across the surface), but rather a varying temperature profile. This condition suggests the requirement for numerous calculations to properly model thermal characteristics of any one surface. Furthermore, the heat flow through a surface at any point is a function of several variables that are not directly related to insulation quality. Among others, these variables include ambient temperature, movement of the air, roughness and emissivity of the heat flow surface, and the radiation exchange with the surroundings (which often vary widely). For calculation of dew formation, variability of the local humidity is an important factor.

Except inside buildings, the average temperature of the radiant background seldom corresponds to the air temperature, and measurement of background temperatures, emissivities and exposure areas is beyond the scope of this International Standard. For these reasons, neither the surface temperature nor the temperature difference between the surface and the air can be used as a reliable indicator of insulation performance or avoidance of dew formation.

Clauses 4 and 5 of this International Standard give the methods used for industrial thermal insulation calculations not covered by more specific standards. In applications where it is not necessary to assure precise values of heat energy conservation or (insulated) surface temperature, or where critical temperatures for dew formation are either not approached or not a factor, these methods can be used to calculate heat flow rates.

Clauses 6 and 7 of this International Standard are adaptations of the general equation for specific applications of calculating heat flow temperature drop and freezing times in pipes and other vessels.

Annexes B and C of this International Standard are for information only.

Thermal insulation for building equipment and industrial installations — Calculation rules

1 Scope

This International Standard gives rules for the calculation of heat-transfer-related properties of building equipment and industrial installations, predominantly under steady-state conditions. This International Standard also gives a simplified approach for the treatment of thermal bridges.

2 Normative references

The following referenced documents are indispensable for the application of this document. For dated references, only the edition cited applies. For undated references, the latest edition of the referenced document (including any amendments) applies.

ISO 7345, *Thermal insulation — Physical quantities and definitions*

ISO 9346, *Hygrothermal performance of buildings and building materials — Physical quantities for mass transfer — Vocabulary*

ISO 10211, *Thermal bridges in building construction — Heat flows and surface temperatures — Detailed calculations*

ISO 13787, *Thermal insulation products for building equipment and industrial installations — Determination of declared thermal conductivity*

ISO 23993, *Thermal insulation for building equipment and industrial installations — Determination of design thermal conductivity*

3 Terms, definitions and symbols

3.1 Terms and definitions

For the purposes of this document, the terms and definitions given in ISO 7345, ISO 9346, ISO 13787 and ISO 23993 apply.

3.2 Definition of symbols

Symbol	Definition	Unit
A	area	m^2
a_r	temperature factor	K^3
C	thickness parameter (see 4.2.2)	m
C_r	radiation coefficient	$W/(m^2 \cdot K^4)$
c_p	specific heat capacity at constant pressure	$kJ/(kg \cdot K)$
D	diameter	m, mm
d	thickness	m, mm
H	height	m
h	surface coefficient of heat transfer	$W/(m^2 \cdot K)$
l	length	m
m	mass	kg
\dot{m}	mass flow rate	kg/h
P	perimeter	m
q	density of heat flow rate	W/m^2
q_d	linear density of heat flow rate for ducts	W/m
q_l	linear density of heat flow rate	W/m
R	thermal resistance	$m^2 \cdot K/W$
R_d	linear thermal resistance of ducts	$m \cdot K/W$
R_l	linear thermal resistance	$m \cdot K/W$
R_{le}	linear thermal surface resistance	$m \cdot K/W$
R_s	surface resistance of heat transfer	$m^2 \cdot K/W$
R_{sph}	thermal resistance for hollow sphere	K/W
t_{fr}	freezing time	h
t_v	cooling time	h
t_{wp}	time until freezing starts	h
T	thermodynamic temperature	K
U	thermal transmittance	$W/(m^2 \cdot K)$
U_l	linear thermal transmittance	$W/(m \cdot K)$
U_{sph}	thermal transmittance for hollow sphere	W/K
U_B	thermal transmittance of thermal bridge	$W/(m^2 \cdot K)$
ΔU_B	additional term corresponding to installation-related and/or irregular insulation-related thermal bridges	$W/(m^2 \cdot K)$
U_T	total thermal transmittance for plane wall	$W/(m^2 \cdot K)$
$U_{T,l}$	total linear thermal transmittance	$W/(m \cdot K)$
$U_{T,sph}$	total thermal transmittance for hollow sphere	W/K
v	air velocity	m/s

Symbol	Definition	Unit
z, y	correction terms for irregular insulation-related thermal bridges	—
z^*, y^*	correction terms for installation-related thermal bridges	—
α	coefficient of longitudinal temperature drop	m^{-1}
α'	coefficient of cooling time	h^{-1}
Δh_{fr}	specific enthalpy; latent heat of freezing	kJ/kg
ε	emissivity	—
Φ	heat flow rate	W
λ	design thermal conductivity	$\text{W}/(\text{m}\cdot\text{K})$
λ_{d}	declared thermal conductivity	$\text{W}/(\text{m}\cdot\text{K})$
θ	Celsius temperature	$^{\circ}\text{C}$
$\Delta\theta$	temperature difference	K
ρ	density	kg/m^3
φ	relative humidity	%
σ	Stefan-Boltzmann constant (see Reference [8])	$\text{W}/(\text{m}^2\cdot\text{K}^4)$

3.3 Subscripts

a	ambient	lab	laboratory
av	average	l	linear
B	thermal bridge	p	pipe
c	cooling	r	radiation
cv	convection	ref	reference
d	design, duct, dew point	s	surface
E	soil	sph	spherical
e	exterior, external	se	surface, exterior
ef	effective	si	surface, interior
fm	final temperature of the medium	T	total
fr	freezing	V	vertical
H	horizontal	v	vessel
i	interior, internal	W	wall
im	initial temperature of the medium	w	water

4 Calculation methods for heat transfer

4.1 Fundamental equations for heat transfer

4.1.1 General

The equations given in Clause 4 apply only to the case of heat transfer in a steady-state, i.e. to the case where temperatures remain constant in time at any point of the medium considered. Generally, the design thermal conductivity is temperature-dependent; see Figure 1, dashed line, which is derived by iterative calculations. However, in this International Standard, the design value for the mean temperature for each layer shall be used.

4.1.2 Thermal conduction

Thermal conduction normally describes molecular heat transfer in solids, liquids and gases under the effect of a temperature gradient.

It is assumed in the calculation that a temperature gradient exists in one direction only and that the temperature is constant in planes perpendicular to it.

The density of heat flow rate, q , for a plane wall in the x -direction is given by Equation (1):

$$q = -\lambda \frac{d\theta}{dx} \quad (1)$$

For a single layer, Equations (2) and (3) hold:

$$q = \frac{\lambda}{d} (\theta_{si} - \theta_{se}) \quad (2)$$

or

$$q = \left(\frac{\theta_{si} - \theta_{se}}{R} \right) \quad (3)$$

where

λ is the design thermal conductivity of the insulation product or system;

d is the thickness of the plane wall;

θ_{si} is the temperature of the internal surface;

θ_{se} is the temperature of the external surface;

R is the thermal resistance of the wall.

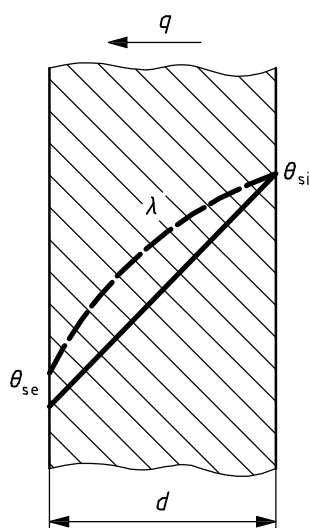

NOTE The straight line shows a negligible temperature dependence on λ and the dashed curve a strong dependence.

Figure 1 — Temperature distribution in a single-layer wall

For multi-layer insulation (see Figure 2), q is calculated according to Equation (4):

$$q = \frac{\theta_{si} - \theta_{se}}{R'} \quad (4)$$

where R' is the thermal resistance of the multi-layer wall, as given in Equation (5):

$$R' = \sum_{j=1}^n \frac{d_j}{\lambda_j} \quad (5)$$

NOTE The prime denotes a multi-layer quantity.

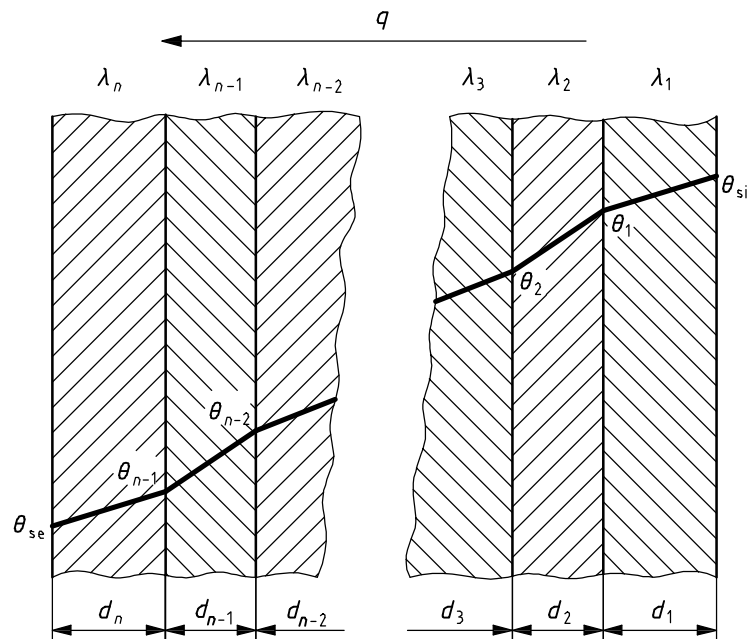

Figure 2 — Temperature distribution in a multi-layer wall

The linear density of heat flow rate, q_l , of a single-layer hollow cylinder (see Figure 3) is given in Equation (6):

$$q_l = \frac{\theta_{si} - \theta_{se}}{R_l} \quad (6)$$

where R_l is the linear thermal resistance of a single-layer hollow cylinder, as given in Equation (7):

$$R_l = \frac{\ln \frac{D_e}{D_i}}{2\pi\lambda} \quad (7)$$

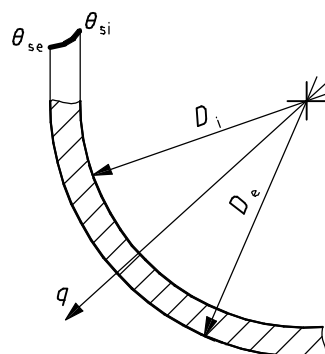

Figure 3 — Temperature distribution in a single-layer hollow cylinder

For multi-layer hollow cylinder (see Figure 4), the linear density of heat flow rate, q_l , is given in Equation (8):

$$q_l = \frac{\theta_{si} - \theta_{se}}{R'_l} \quad (8)$$

where R'_l is given by Equation (9)

$$R'_l = \frac{1}{2\pi} \sum_{j=1}^n \left(\frac{1}{\lambda_j} \ln \frac{D_{ej}}{D_{ij}} \right) \quad (9)$$

where

$$D_0 = D_i$$

$$D_n = D_e$$

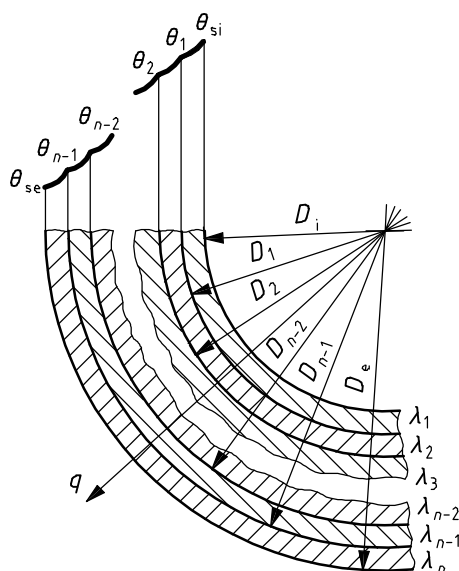

Figure 4 — Temperature distribution in a multi-layer hollow cylinder

The heat flow rate, Φ_{sph} , of a single-layer hollow sphere (see Figure 5) is as given in Equation (10):

$$\Phi_{sph} = \frac{\theta_{si} - \theta_{se}}{R_{sph}} \quad (10)$$

where R_{sph} is the thermal resistance of a single-layer hollow sphere, as given in Equation (11):

$$R_{sph} = \frac{1}{2\pi\lambda} \left(\frac{1}{D_i} - \frac{1}{D_e} \right) \quad (11)$$

where

D_e is the outer diameter of the layer;

D_i is the inner diameter of the layer.

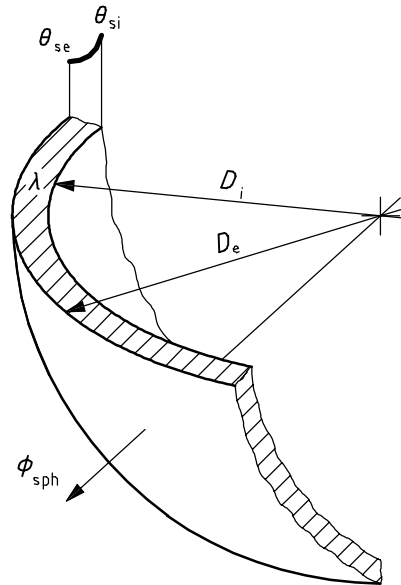

Figure 5 — Temperature distribution in a single-layer hollow sphere

The heat flow rate, ϕ_{sph} , of a multi-layer hollow sphere (see Figure 6) is as given in Equation (12):

$$\phi_{sph} = \frac{\theta_{si} - \theta_{se}}{R'_{sph}} \quad (12)$$

where R'_{sph} is as given in Equation (13):

$$R'_{sph} = \frac{1}{2\pi} \sum_{j=1}^n \frac{1}{\lambda_j} \left(\frac{1}{D_{j-1}} - \frac{1}{D_j} \right) \quad (13)$$

$$D_0 = D_i$$

$$D_n = D_e$$

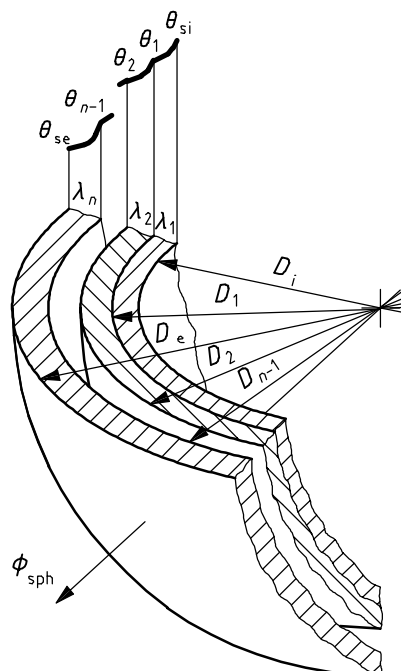

Figure 6 — Temperature distribution in a multi-layer hollow sphere

The linear density of heat flow rate, q_d , through the wall of a duct with rectangular cross-section (see Figure 7) is as given in Equation (14):

$$q_d = \frac{\theta_{si} - \theta_{se}}{R_d} \quad (14)$$

The linear thermal resistance, R_d , of the wall of such a duct can be approximately calculated as given in Equation (15):

$$R_d = \frac{2d}{\lambda(P_e + P_i)} \quad (15)$$

where

d is the thickness of the insulating layer;

P_i is the inner perimeter of the duct;

P_e is the external perimeter of the duct, as given in Equation (16):

$$P_e = P_i + (8 \times d) \quad (16)$$

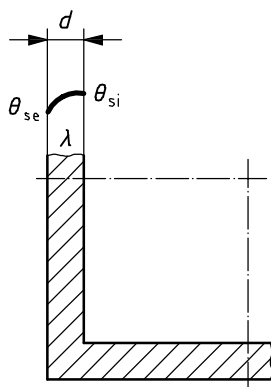

Figure 7 — Temperature distribution in a wall of a duct with rectangular cross-section at temperature-dependent thermal conductivity

4.1.3 Surface coefficient of heat transfer

In general, the surface coefficient of heat transfer, h , is given by Equation (17):

$$h = h_r + h_{cv} \quad (17)$$

where

h_r is the radiative part of the surface coefficient of heat transfer;

h_{cv} is the convective part of the surface coefficient of heat transfer.

NOTE 1 h_r is dependent on the temperature and the emissivity of the surface. Emissivity is defined as the ratio between the radiation coefficient of the surface and the black body radiation constant (see ISO 9288).

NOTE 2 h_{cv} is, in general, dependent on a variety of factors, such as air movement, temperature, the relative orientation of the surface, the material of the surface and other factors.

4.1.3.1 Radiative part of surface coefficient, h_r

h_r is given by Equation (18):

$$h_r = a_r C_r \quad (18)$$

where

a_r is the temperature factor;

C_r is the radiation coefficient, as given by Equation (21).

The temperature factor, a_r , is given by Equation (19):

$$a_r = \frac{(T_1)^4 - (T_2)^4}{T_1 - T_2} \quad (19)$$

and can be approximated up to a temperature difference of 200 K by Equation (20):

$$a_r \approx 4 \times (T_{av})^3 \quad (20)$$

where T_{av} is the arithmetic mean of the surface temperature and the mean radiant temperature of the surroundings.

The radiation coefficient, C_r , is given by Equation (21):

$$C_r = \varepsilon \sigma \quad (21)$$

where σ is the Stefan-Boltzmann constant [$5,67 = 10^{-8} \text{ W}/(\text{m}^2 \cdot \text{K}^4)$].

4.1.3.2 Convective part of surface coefficient, h_{cv}

4.1.3.2.1 General

For convection, it is necessary to make a distinction between the surface coefficient inside buildings and that in open air. For pipes and containers, there is a difference as well between the internal surface coefficient, h_i , and the external surface coefficient, h_{se} .

NOTE In most cases, h_i can be neglected by assuming that the inner surface temperature equals the temperature of the medium.

4.1.3.2.2 Inside buildings

In the interior of buildings, h_{cv} can be calculated for plane vertical walls and vertical pipes for laminar, free convection ($H^3 \Delta\theta \leq 10 \text{ m}^3 \cdot \text{K}$) by Equation (22):

$$h_{cv} = 1,32 \times \sqrt[4]{\frac{\Delta\theta}{H}} \quad (22)$$

where

$$\Delta\theta = |\theta_{se} - \theta_a|;$$

θ_{se} is the surface temperature of the wall;

θ_a is the temperature of the ambient air inside the building;

H is the height of the wall or diameter of a pipe.

For vertical plane walls and vertical pipes, and as an approximation for large spheres inside buildings, the convective part, h_{cv} , for turbulent, free convection ($H^3\Delta\theta > 10 \text{ m}^3\cdot\text{K}$) is given by Equation (23):

$$h_{cv} = 1,74 \times \sqrt[3]{\Delta\theta} \quad (23)$$

Equations (22) and (23) may also be used for horizontal surfaces inside buildings.

NOTE This means that the same coefficient is used for all surfaces of a rectangular duct.

For horizontal pipes inside buildings, h_{cv} is given by Equation (24) for laminar airflow ($D_e^3\Delta\theta \leq 10 \text{ m}^3\cdot\text{K}$) and by Equation (25) for turbulent airflow ($D_e^3\Delta\theta > 10 \text{ m}^3\cdot\text{K}$):

$$h_{cv} = 1,25 \times \sqrt[4]{\frac{\Delta\theta}{D_e}} \quad (24)$$

$$h_{cv} = 1,21 \times \sqrt[3]{\Delta\theta} \quad (25)$$

4.1.3.2.3 Outside buildings

For vertical plane walls outside buildings and as an approximation for large spheres, the convective part, h_{cv} , of the surface coefficient is given by Equation (26) for laminar airflow ($vH \leq 8 \text{ m}^2/\text{s}$) and by Equation (27) for turbulent airflow ($vH > 8 \text{ m}^2/\text{s}$):

$$h_{cv} = 3,96 \times \sqrt{\frac{v}{H}} \quad (26)$$

$$h_{cv} = 5,76 \times \sqrt[5]{\frac{v^4}{H}} \quad (27)$$

Equations (26) and (27) may also be used for horizontal surfaces outside buildings.

For horizontal and vertical pipes that are outside buildings, Equation (28) applies for laminar airflow ($vD_e \leq 8,55 \times 10^{-3} \text{ m}^2/\text{s}$) and Equation (29) for turbulent airflow ($vD_e > 8,55 \times 10^{-3} \text{ m}^2/\text{s}$):

$$h_{cv} = \frac{8,1 \times 10^{-3}}{D_e} + 3,14 \times \sqrt{\frac{v}{D_e}} \quad (28)$$

$$h_{cv} = 8,9 \times \frac{v^{0,9}}{D_e^{0,1}} \quad (29)$$

where

D_e is the external insulation diameter, expressed in metres;

v is the air velocity, expressed in metres per second.

For calculation of the surface temperature, Equations (22) to (25) should be used for wall and pipe instead of Equations (26) to (29) when the presence of wind is not established.

Table 1 the gives number of the appropriate equation to use to calculate h_{cv} for different building elements.

Table 1 — Selection of the equation to calculate h_{cv}

Location	Walls				Pipes			
	vertical		horizontal		vertical		horizontal	
	laminar	turbulent	laminar	turbulent	laminar	turbulent	laminar	turbulent
inside buildings	(22)	(23)	(22)	(23)	(22)	(23)	(24)	(25)
outside buildings	(26)	(27)	(26)	(27)	(28)	(29)	(28)	(29)

All the equations for the convective part of the outer thermal surface coefficient inside buildings apply to the heat transfer between surfaces and air at temperature differences $\Delta T < 100$ K.

NOTE The change from an equation for laminar flow to that for turbulent flow can result in a step change in the convection coefficient for an incremental change in v or H . This is a result of the approximations used for the equations.

4.1.3.3 Approximation for the calculation of h_{se}

The outer surface coefficient, h_{se} , can be calculated approximately using the coefficients in Table 2, together with Equation (30) for horizontal pipes inside buildings or Equation (31) for vertical pipes and walls inside buildings:

$$h_{se} = C_H + 0,05 \times \Delta\theta \quad (30)$$

$$h_{se} = C_V + 0,09 \times \Delta\theta \quad (31)$$

Equation (30) can be used for horizontal pipe in the range $D_e = 0,25$ m to 1,0 m and Equation (31), for vertical pipe of all diameters.

Table 2 — Coefficients C_H and C_V for approximate calculation of total exterior thermal surface coefficient

Surface	C_H	C_V	ε	$C_r \times 10^{-8}$ W/(m ² ·K ⁴)
Aluminium, bright rolled	2,5	2,7	0,05	0,28
Aluminium, oxidized	3,1	3,3	0,13	0,74
Galvanized sheet metal, blank	4,0	4,2	0,26	1,47
Galvanized sheet metal, dusty	5,3	5,5	0,44	2,49
Austenitic steel	3,2	3,4	0,15	0,85
Aluminium-zinc sheet	3,4	3,6	0,18	1,02
Non-metallic surfaces	8,5	8,7	0,94	5,33

For cylindrical ducts with a diameter less than 0,25 m, the convective part of the external surface coefficient can be calculated to a good approximation by Equation (24). For larger diameters, i.e. $D_e > 0,25$ m, the equation for plane walls, Equation (22), can be applied. The respective accuracy is 5 % for diameters $D_e > 0,4$ m and 10 % for diameters $0,25$ m $< D_e < 0,40$ m. Equation (22) is also used for ducts with a rectangular cross-section, having a width and height of similar magnitude.

4.1.3.4 External surface resistance

The reciprocal of the outer surface coefficient, h_{se} , is the external surface resistance.

For plane walls, the surface resistance, R_{se} , is given by Equation (32):

$$R_{se} = \frac{1}{h_{se}} \quad (32)$$

For pipe insulation, the linear thermal surface resistance, R_{le} , is given by Equation (33):

$$R_{le} = \frac{1}{h_{se} \pi D_e} \quad (33)$$

For hollow spheres, the thermal surface resistance, $R_{sph,e}$, is given by Equation (34):

$$R_{sph,e} = \frac{1}{h_{se} \pi D_e^2} \quad (34)$$

4.1.4 Thermal transmittance

4.1.4.1 General

The thermal transmittance, U , for plane walls and the linear thermal transmittance, U_l , for pipes shall be calculated in accordance with 4.1.4.2, using the design values of thermal conductivity according to ISO 23993.

After this calculation, the values of the thermal transmittances U and U_l shall be increased in accordance with 4.1.4.3 to take into account influences of either installation-related or irregular insulation-related thermal bridges to determine the total thermal transmittance.

4.1.4.2 Thermal transmittance without thermal bridge corrections

The thermal transmittance, U , is defined by Equation (35):

$$U = \frac{q}{\theta_i - \theta_a} \quad (35)$$

where

θ_a is the ambient external temperature;

θ_i is the internal air temperature for plane walls or the temperature of the medium inside for pipes, ducts and vessels.

For plane walls, the thermal transmittance, U , can be calculated by Equation (36):

$$\begin{aligned} \frac{1}{U} &= \frac{1}{h_i} + R + \frac{1}{h_{se}} \\ &= R_{si} + R + R_{se} \\ &= R_T \end{aligned} \quad (36)$$

For pipe insulation, the linear thermal transmittance, U_l , can be calculated by Equation (37):

$$\begin{aligned} \frac{1}{U_l} &= \frac{1}{h_i \pi D_i} + R_l + \frac{1}{h_{se} \pi D_e} \\ &= R_{li} + R_l + R_{le} \\ &= R_{T,l} \end{aligned} \quad (37)$$

For rectangular ducts, the linear thermal transmittance, U_d , can be calculated by Equation (38):

$$\frac{1}{U_d} = \frac{1}{h_i P_i} + R_d + \frac{1}{h_e P_e} \quad (38)$$

$$= R_{T,d}$$

For hollow spheres, the thermal transmittance, U_{sph} , is given by Equation (39):

$$\frac{1}{U_{sph}} = \frac{1}{h_i \pi D_i^2} + R_{sph} + \frac{1}{h_{se} \pi D_e^2} \quad (39)$$

$$= R_{T,sph}$$

In Equations (36) to (39), R , R_i and R_{sph} are surface-to-surface thermal resistances.

The surface resistance of flowing media in pipes, R_{si} (in the cases predominantly considered here) is small and can be neglected. For the external surface coefficient, h_{se} , Equations (30) and (31) apply. For ducts, it is necessary to include the internal surface coefficient as well. It can be approximated using the appropriate equations in Clause 4, taking into account the velocity of the medium in the duct.

The reciprocal of thermal transmittance, U , is the total thermal resistance, R_T , for plane walls, the total linear thermal resistance, $R_{T,l}$, for pipe insulation and $R_{T,sph}$ for hollow sphere insulation.

4.1.4.3 Determination of total thermal transmittance

For plane walls, the total thermal transmittance, U_T , shall be determined by Equation (40):

$$U_T = U + \Delta U_B \quad (40)$$

For pipes, the total linear thermal transmittance, $U_{T,l}$, shall be determined by Equation (41):

$$U_{T,l} = U_l + \Delta U_{B,l} \quad (41)$$

For hollow spheres, the total thermal transmittance, $U_{T,sph}$, shall be determined by Equation (42):

$$U_{T,sph} = U_{sph} + \Delta U_{B,sph} \quad (42)$$

where ΔU_B , $\Delta U_{B,l}$ and $\Delta U_{B,sph}$ are calculated in accordance with Clause 7.

4.1.5 Temperatures of the layer boundaries

The general equation for the density of the heat flow rate in a multi-layer wall is written in the general form given by Equations (43) and (44) (see also Figure 8):

$$q = \frac{\theta_i - \theta_a}{R_T} \quad (43)$$

$$R_T = R_{si} + R_1 + R_2 + \dots + R_n + R_{se} \quad (44)$$

where

$R_1 \dots R_n$ are the thermal resistances of the individual layers and R_{si} and R_{se} are the thermal surface resistances of the internal and external surfaces, respectively.

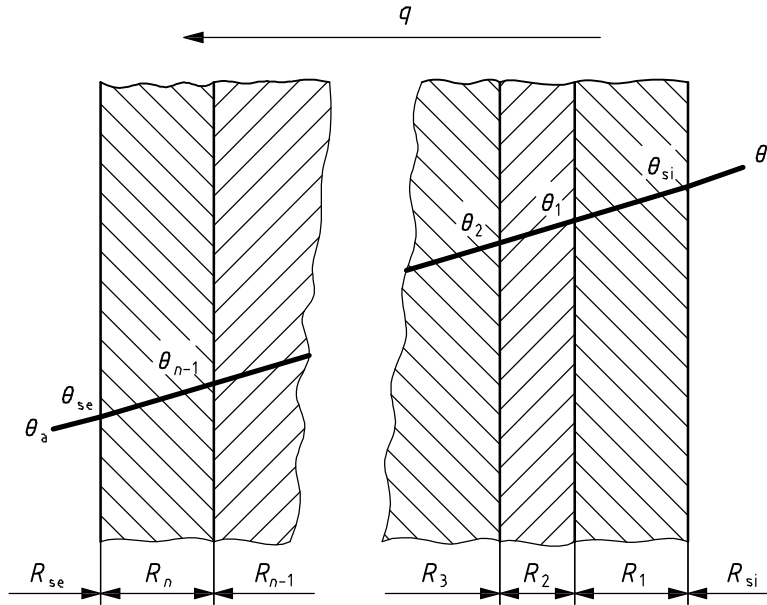

Figure 8 — The temperature distribution for a multi-layer plane wall in relation to the thermal surface resistance and the thermal resistances of layers

The ratio between the resistance of each layer or the surface resistance with respect to the total resistance gives a measure of the temperature change across the particular layer or surface, expressed in K, as given in Equations (45) to (48):

$$\theta_i - \theta_{si} = \frac{R_{si}}{R_T} (\theta_i - \theta_a) \tag{45}$$

$$\theta_{si} - \theta_1 = \frac{R_1}{R_T} (\theta_i - \theta_a) \tag{46}$$

$$\theta_1 - \theta_2 = \frac{R_2}{R_T} (\theta_i - \theta_a) \tag{47}$$

$$\theta_{se} - \theta_a = \frac{R_{se}}{R_T} (\theta_i - \theta_a) \tag{48}$$

R_T is calculated for plane walls according to Equation (36), for cylindrical pipes according to Equation (37), for rectangular ducts according to Equation (38) and for spherical insulation according to Equation (39).

4.2 Surface temperature

4.2.1 General

The surface temperature can be calculated by using Equation (45) or Equation (48).

For operational reasons, it is often stipulated in practice that a certain surface temperature or temperature of the surface higher than that of the ambience should be maintained. However, the surface temperature is not necessarily a measure of the quality of the thermal insulation. This depends on the design thermal conductivity but also on operating conditions, which cannot be readily determined or warranted by the manufacturer. These include operating temperatures of the medium, ambient temperature, movement of the air, state of the insulation surface, effect of adjacent radiating bodies, meteorological conditions, etc.

With all these parameters, it is possible to estimate the required insulation thickness using Equation (48) or Figure 9 (see Reference [9]). It is necessary to point out, however, that these assumptions correspond to the subsequent operating conditions only in very rare cases.

Since an accurate registration of all relevant parameters is impossible, the calculation of the surface temperature is inexact and the surface temperature cannot be warranted. The same restrictions apply to the warranty of the temperature difference between surface and air, also called excess temperature. Although it includes the effect of the ambient temperature on the surface temperature, it assumes that the heat transfer by convection and radiation can be covered by a total heat transfer coefficient whose magnitude it is also necessary to know (see 4.1.2). However, this condition is generally not fulfilled because the air temperature in the immediate vicinity of the surface, which determines the convective heat transfer, usually differs from the temperature of other surfaces with which the insulation surface is in radiative exchange.

4.2.2 Example calculation for the thickness parameter, C'

The thickness parameter, C' , is calculated as given by Equations (49) and (50):

$$C' = 2\lambda \left[\left(\frac{|\theta_{im} - \theta_a|}{q} \right) - \frac{1}{h_{se}} \right] \quad (49)$$

$$C' = \frac{2\lambda}{h_{se}} \left[\left(\frac{|\theta_{im} - \theta_a|}{|\theta_{se} - \theta_a|} \right) - 1 \right] \quad (50)$$

Example using Equation (49): Set heat flux, q

$$\begin{aligned} \theta_{im} &= 300 \text{ }^\circ\text{C} & \lambda &= 0,068 \text{ W/(m}\cdot\text{K)} \\ \theta_a &= 20 \text{ }^\circ\text{C} & D &= 0,324 \text{ m} \\ h_{se} &= 5,7 \text{ W/(m}^2\cdot\text{K)} & q &= 63 \text{ W/m}^2 \end{aligned}$$

In accordance with Figure 9:

$$\begin{aligned} C' &= 2\lambda \left(\frac{|\theta_{im} - \theta_a|}{q} - \frac{1}{h_{se}} \right) \\ &= 2 \times 0,068 \left(\frac{|300 - 20|}{63} - \frac{1}{5,7} \right) = 0,58 \text{ m} \end{aligned}$$

Result: $d = 200 \text{ mm}$

Example using Equation (50): Set surface temperature for dew prevention

$$\begin{aligned} \theta_{im} &= -20 \text{ }^\circ\text{C} & \lambda &= 0,039 \text{ W/(m}\cdot\text{K)} \\ \theta_a &= 20 \text{ }^\circ\text{C} & D &= 0,108 \text{ m} \\ h_{se} &= 5,4 \text{ W/(m}^2\cdot\text{K)} & \varphi &= 85 \text{ \%} \end{aligned}$$

In accordance with Table 4:

$$\begin{aligned} |\theta_d - \theta_a| &= |\theta_{se} - \theta_a| = 2,6 \text{ K} \\ C' &= \frac{2\lambda}{h_{se}} \left(\frac{|\theta_{im} - \theta_a|}{|\theta_{se} - \theta_a|} - 1 \right) \\ &= \frac{2 \times 0,039}{5,4} \left(\frac{|-20 - 20|}{2,6} - 1 \right) = 0,208 \text{ m} \end{aligned}$$

Result: $d = 70 \text{ mm}$

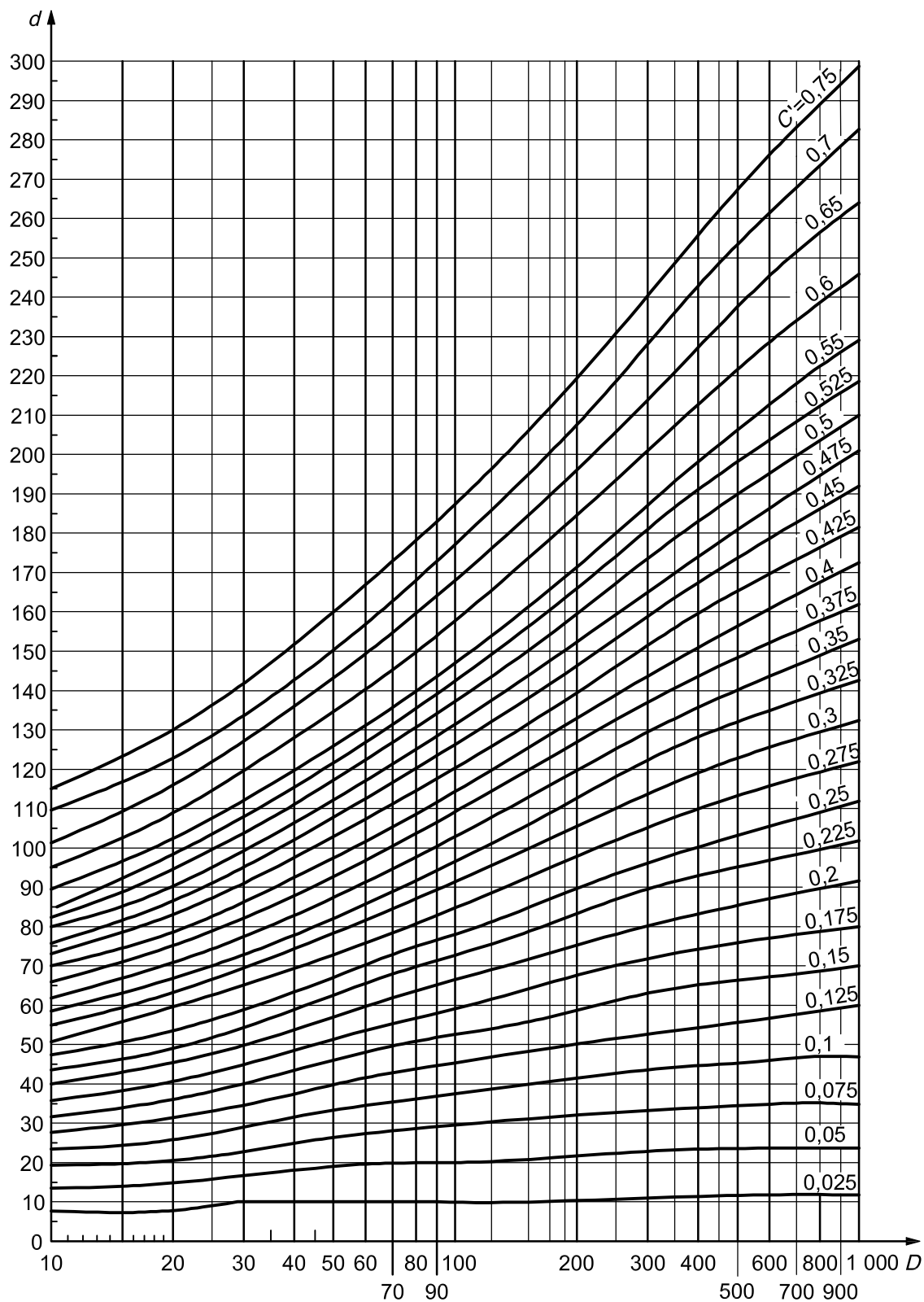

Key

- D diameter, expressed in millimetres
- d thickness, expressed in millimetres
- C' thickness parameter, expressed in metres

Figure 9 — Determination of insulating layer thickness for a pipe at a given heat flux density or for a set surface temperature

The equations for the thickness parameter C' are derived from Equations (35) and (37) by elementary transformations. Equation (49) enables the calculation of the necessary insulation thickness for a given linear density of heat flow rate, whereas Equation (50) enables the calculation of the required insulation thickness for a given temperature difference between the pipe surface (with insulation) and the ambient temperature.

In both cases, h_{se} is assumed or calculated (see Clause C.7).

4.3 Prevention of surface condensation

Surface condensation depends not only on the parameters affecting the surface temperature but also on the relative humidity of the surrounding air, which very often cannot be stated accurately by the customer. The higher the relative humidity, the more the fluctuations of humidity or of surface temperatures increase the risk of surface condensation. Unless other data are available, it is necessary to make assumptions as in Table 3 to calculate the necessary insulation thickness to prevent dew formation on pipes. Using Equation (48), the necessary insulation thickness to prevent dew formation can be obtained by iterative techniques. The allowed temperature difference, expressed in K, between surface and the ambient air for different relative humidities at the start of dew formation is given in Table 4.

Table 3 — Insulation thickness required to prevent dew formation for refrigerant pipes

Ext. pipe Ø mm	Relative air humidity 80 %																		
	Temperature of the medium °C																		
	+15	+10	+5	0	-5	-10	-15	-20	-25	-30	-35	-40	-45	-50	-55	-60	-65	-70	-75
17,2																			
21,3																			
26,9																			
33,7		15		25	30		40		50					65					
38																			
42,4																			
48,3																			
60,3																80			
70																			
76,1																			
82,5																			
88,9																	90		
95																			
101,6																			
108																			
114,3																			
121																			
127																	100		
133																			
139,7																			
159																			
177,8																			
193,7																			
219,1																			
244,5																			
273																			
298,5																	120		
318																			
323,9																			
355,6	15	25	30	40	50	65	80												
406,4																			
419												90							
470																			
508												100							
558,8																			
609,6															120				
711,2																			
812,2																	140		
914,4																			
1 016																			
∞																			

The following values are assumed:
 — thermal conductivity of the insulation at $\theta = 10\text{ °C}$, $\lambda = 0,04\text{ W/(m·K)}$;
 — thermal conductivity of the insulation at $\theta = -100\text{ °C}$, $\lambda = 0,033\text{ W/(m·K)}$;
 — ambient air temperature of 20 °C ;
 — $h_{se} = 6\text{ W/(m}^2\cdot\text{K)}$.

Licensed copy: Lee Shau Kee Library, HKUST, Version correct as of 03/01/2015, (c) The British Standards Institution 2013

of different diameters and different temperatures at different relative humidities of the ambient air

Relative air humidity 85 %																		Ext. pipe Ø mm	
Temperature of the medium °C																			
+15	+10	+5	0	-5	-10	-15	-20	-25	-30	-35	-40	-45	-50	-55	-60	-65	-70		-75
																			17,2
																			21,3
	15		30		40		50		65					80					26,9
																			33,7
															90				38
																			42,4
																			48,3
																	100		60,3
	15																		70
		25																	76,1
			40																82,5
				50															88,9
					65														95
									80									120	101,6
																			108
																			114,3
																			121
											90								127
												100							133
																			139,7
	25																		159
		30													120				177,8
			40																193,7
				40															219,1
																			244,5
																140			273
																			298,5
																			318
			50																323,9
																			355,6
																			406,4
				65														160	419
																			470
							80												508
								90	100	120			140						558,8
																			609,6
															160				711,2
																	180		812,2
																			914,4
																			1 016
																			∞

The following values are assumed:

- thermal conductivity of the insulation at $\theta = 10\text{ °C}$, $\lambda = 0,04\text{ W/(m·K)}$;
- thermal conductivity of the insulation at $\theta = -100\text{ °C}$, $\lambda = 0,033\text{ W/(m·K)}$;
- ambient air temperature of 20 °C ;
- $h_{se} = 6\text{ W/(m}^2\text{·K)}$.

Table 4 — The allowed temperature difference in kelvin (K) between surface and ambient air for different relative humidities at the onset of dew formation

Ambient air temperature °C	Relative air humidity %													
	30	35	40	45	50	55	60	65	70	75	80	85	90	95
-20	—	10,4	9,1	8,0	7,9	6,0	5,2	4,5	3,7	2,9	2,3	1,7	1,1	0,5
-15	12,3	10,8	9,6	8,3	7,3	6,4	5,4	4,6	3,8	3,1	2,5	1,8	1,2	0,6
-10	12,9	11,3	9,9	8,7	7,6	6,6	5,7	4,8	3,9	3,2	2,5	1,8	1,2	0,6
-5	13,4	11,7	10,3	9,0	7,9	6,8	5,8	5,0	4,1	3,3	2,6	1,9	1,2	0,6
0	13,9	12,2	10,7	9,3	8,1	7,1	6,0	5,1	4,2	3,5	2,7	1,9	1,3	0,7
2	14,3	12,6	11,0	9,7	8,5	7,4	6,4	5,4	4,6	3,8	3,0	2,2	1,5	0,7
4	14,7	13,0	11,4	10,1	8,9	7,7	6,7	5,8	4,9	4,0	3,1	2,3	1,5	0,7
6	15,1	13,4	11,8	10,4	9,2	8,1	7,0	6,1	5,1	4,1	3,2	2,3	1,5	0,7
8	15,6	13,8	12,2	10,8	9,6	8,4	7,3	6,2	5,1	4,2	3,2	2,3	1,5	0,8
10	16,0	14,2	12,6	11,2	10,0	8,6	7,4	6,3	5,2	4,2	3,3	2,4	1,6	0,8
12	16,5	14,6	13,0	11,6	10,1	8,8	7,5	6,3	5,3	4,3	3,3	2,4	1,6	0,8
14	16,9	15,1	13,4	11,7	10,3	8,9	7,6	6,5	5,4	4,3	3,4	2,5	1,6	0,8
16	17,4	15,5	13,6	11,9	10,4	9,0	7,8	6,6	5,4	4,4	3,5	2,5	1,7	0,8
18	17,8	15,7	13,8	12,1	10,6	9,2	7,9	6,7	5,6	4,5	3,5	2,6	1,7	0,8
20	18,1	15,9	14,0	12,3	10,7	9,3	8,0	6,8	5,6	4,6	3,6	2,6	1,7	0,8
22	18,4	16,1	14,2	12,5	10,9	9,5	8,1	6,9	5,7	4,7	3,6	2,6	1,7	0,8
24	18,6	16,4	14,4	12,6	11,1	9,6	8,2	7,0	5,8	4,7	3,7	2,7	1,8	0,8
26	18,9	16,6	14,7	12,8	11,2	9,7	8,4	7,1	5,9	4,8	3,7	2,7	1,8	0,9
28	19,2	16,9	14,9	13,0	11,4	9,9	8,5	7,2	6,0	4,9	3,8	2,8	1,8	0,9
30	19,5	17,1	15,1	13,2	11,6	10,1	8,6	7,3	6,1	5,0	3,8	2,8	1,8	0,9
35	20,2	17,7	15,7	13,7	12,0	10,4	9,0	7,6	6,3	5,1	4,0	2,9	1,9	0,9
40	20,9	18,4	16,1	14,2	12,4	10,8	9,3	7,9	6,5	5,3	4,1	3,0	2,0	1,0
45	21,6	19,0	16,7	14,7	12,8	11,2	9,6	8,1	6,8	5,5	4,3	3,1	2,1	1,0
50	22,3	19,7	17,3	15,2	13,3	11,6	9,9	8,4	7,0	5,7	4,4	3,2	2,1	1,0

EXAMPLE At an ambient temperature of 20 °C and 70 % relative humidity, the allowed surface temperature is 20 °C – 5,6 °C = 14,4 °C.

4.4 Determination of total heat flow rate for plane walls, pipes and spheres

The total heat flow rate of a plane wall is given by Equation (51):

$$\Phi_T = U_T A (\theta_{im} - \theta_a) \quad (51)$$

The total heat flow rate of a pipe is given by Equation (52):

$$\Phi_T = U_{T,l} l (\theta_{im} - \theta_a) \quad (52)$$

The total heat flow rate of a sphere is given by Equation (53):

$$\Phi_T = U_{T,\text{sph}} (\theta_{\text{im}} - \theta_a) \quad (53)$$

5 Calculation of the temperature change in pipes, vessels and containers

5.1 Longitudinal temperature change in a pipe

To obtain an accurate value of the longitudinal temperature change in a pipe with a flowing medium, i.e. liquid or gas, Equations (54) and (55) apply:

$$|\theta_{\text{fm}} - \theta_a| = |\theta_{\text{im}} - \theta_a| e^{-\alpha l} \quad (54)$$

where

$$\alpha = \frac{U_{T,l} \times 3,6}{\dot{m} c_p} \quad (55)$$

θ_{fm} is the final temperature of the medium, expressed in degrees Celsius;

θ_{im} is the initial temperature of the medium, expressed in degrees Celsius;

θ_a is the ambient temperature, expressed in degrees Celsius;

c_p is the specific heat capacity at constant pressure of the flowing medium, expressed in kilojoules per kilogram kelvin;

\dot{m} is the mass flow rate of the flowing medium, expressed in kilograms per hour;

l is the length of the pipe, expressed in metres;

$U_{T,l}$ is the total linear thermal transmittance, expressed in watts per metre kelvin.

Equations (54) and (55) can also be used for ducts with rectangular cross-section if $U_{T,l}$ is replaced by U_d [Equation (38)].

Since, in practice, the allowed temperature change is often small, Equation (56) may be used for an approximate calculation:

$$\Delta\theta = \frac{\Phi_{T,l} \times 3,6}{\dot{m} c_p} \quad (56)$$

where

$\Phi_{T,l}$ is the total linear heat flow rate, expressed in watts;

$\Delta\theta$ is the longitudinal temperature change, expressed in kelvin.

Equation (56) yields results of sufficient accuracy only for relatively short pipes and a relatively small temperature change [$\Delta\theta \leq 0,06 \times (\theta_{\text{im}} - \theta_a)$].

5.2 Temperature change and cooling times in pipes, vessels and containers

The cooling time, t_v , for the temperature drop, expressed in hours, is calculated by Equation (57):

$$t_v = \frac{(\theta_{im} - \theta_a) m c_p \ln \frac{(\theta_{im} - \theta_a)}{(\theta_{fm} - \theta_a)}}{\Phi_T \times 3,6} \quad (57)$$

where

Φ_T is given by Equation (51) for plane walls, by Equation (52) for pipes and by Equation (53) for spheres;

m is the mass of contents, expressed in kilograms;

c_p is the specific heat capacity of the medium, expressed in kilojoules per kilogram kelvin.

Accurate calculation of the time-dependent temperature change is performed according to 5.1, using Equations (54) and (55) and replacing l by t and α by α' as given by Equation (58):

$$\alpha' = \frac{U_T A \times 3,6}{m c_p} \quad (58)$$

The approximate time-dependent temperature drop can be calculated by Equation (59):

$$\Delta\theta = \frac{\Phi_T}{m c_p} t \times 3,6 \quad (59)$$

NOTE In calculating the cooling time, it is assumed that no heat is absorbed by the media during cooling. The cooling time obtained on this basis is the fastest, which means there is a safety factor built into the calculation (for design purposes). For small containers, the heat capacity of the container itself can be taken into account by including in Equation (57) a term analogous to that in Equation (60).

6 Calculation of cooling and freezing times of stationary liquids

6.1 Calculation of the cooling time for a given thickness of insulation to prevent the freezing of water in a pipe

It is not possible to prevent the freezing of a liquid in a pipe, although insulated, over an arbitrarily long period of time if the ambient temperature is below the freezing point of the liquid.

As soon as the liquid (normally water) in the pipe is stationary, the process of cooling starts. The heat flow rate, Φ_T , of a stationary liquid is determined by the temperature difference, the properties of the thermal insulation as well as the pipe geometry. In addition, the energy stored in the liquid, $m_w c_{pw}$, and in the pipe material, $m_p c_{pp}$, as well as by the freezing enthalpy required to transform water to ice, shall be taken into account. If $m_p c_{pp} \ll m_w c_{pw}$, then $m_p c_{pp}$ may be neglected.

The time until freezing starts is calculated using Equation (60):

$$t_{wp} = \frac{(\theta_{im} - \theta_a)(m_w c_{pw} + m_p c_{pp}) \ln \frac{(\theta_{im} - \theta_a)}{(\theta_{fm} - \theta_a)}}{\Phi_T \times 3,6} \quad (60)$$

where

Φ_T is the total heat flow rate, expressed in watts;

θ_{im} is the initial medium temperature, expressed in degrees Celsius;

θ_{fm} is the final medium temperature, expressed in degrees Celsius;

θ_a is the ambient temperature, expressed in degrees Celsius;

c_p is the specific heat capacity, expressed in kilojoules per kilogram kelvin;

m_w is the mass of water, expressed in kilograms;

m_p is the mass of the pipe, expressed in kilograms.

In practice, for the calculation of Φ_T , the exterior thermal surface resistance should be neglected for insulated pipes.

If a comparison is made between uninsulated and insulated pipes, neglecting thermal bridges, the influence of the surface coefficient of the uninsulated pipe shall be taken into consideration. The heat flow rate of the uninsulated pipe is given by Equation (61):

$$\Phi_T = h_{se} (\theta_{im} - \theta_a) \pi D_e l \quad (61)$$

An approximation of the cooling time is given by Equation (62):

$$t_{wp} = \frac{(m_w c_{pw} + m_p c_{pp}) (\theta_{im} - \theta_{fm})}{\Phi_T \times 3,6} \quad (62)$$

The time until freezing starts is calculated by using the procedure above with θ_{fm} equal to the freezing point of the liquid.

The maximum allowed cooling time of water in pipes of different diameter and with different insulation thicknesses at different ambient temperatures to avoid freezing of the water in the pipe is shown in Figure 10.

EXAMPLE For a given pipe diameter of 300 mm with an insulation thickness of 60 mm and an ambient temperature of -10 °C, the maximum allowed cooling time is 40 h.

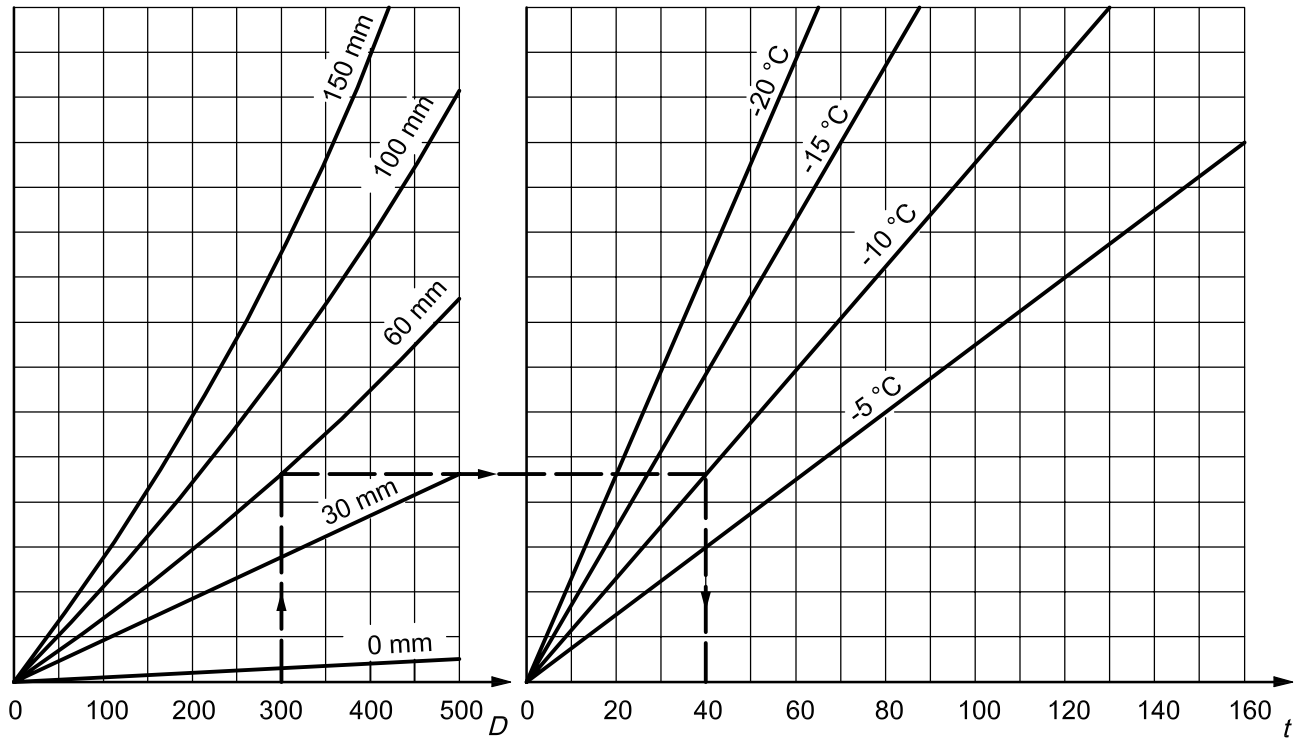

Key

- D diameter, expressed in millimetres
- t time, expressed in hours

NOTE The data are for an initial temperature $\theta = 5\text{ °C}$, wind speed $v = 5\text{ m/s}$, $\lambda = 0,040\text{ W/(m}\cdot\text{K)}$ and $h_e = 20\text{ W/(m}^2\cdot\text{K)}$.

Figure 10 — Determination of cooling times from 5 °C to 0 °C

6.2 Calculation of the freezing time of water in a pipe

The freezing time, t_{fr} , is dependent on the density of heat flow rate and the diameter of the pipe neglecting thermal bridges. It is given by Equation (63):

$$t_{fr} = \frac{f}{100} \times \frac{\rho_{ice} \pi D_{ip}^2 \Delta h_{fr}}{\Phi_{T,fr} \times 3,6 \times 4} \tag{63}$$

where

- f is the mass fraction of water that is frozen, expressed in percent;
- D_{ip} is the interior pipe diameter, expressed in metres;
- Δh_{fr} is the latent heat of ice formation, equal to 334 kJ/kg;
- ρ_{ice} is the density of ice at 0 °C, equal to 920 kg/m³.

The heat flow rate of freezing, $\Phi_{T,fr}$, can be calculated from Equation (64):

$$\Phi_{T,fr} = \frac{\pi(-\theta_a)}{\frac{1}{2\lambda} \ln \frac{D_e}{D_i}} l \quad (64)$$

The percentage, f , of water that is frozen shall be chosen according to a requirement, i.e. 25 % ($f = 25$).

Alternatively, the cooling time may be taken from Figure 10.

To allow for the effect of the reduced cross-section of slides, taps and fittings, it is recommended that the cooling and freezing times, t_{wp} and t_{fr} , given in 6.1 and this subclause, respectively, be reduced by 25 %.

7 Determination of the influence of thermal bridges

7.1 General

The correction, ΔU_B , to allow for the additional heat transfer due to thermal bridges in an industrial installation with plane surfaces, shall be calculated using Equation (65):

$$\Delta U_B = U \left[\sum_{j=1}^n z_j + \sum_{j=1}^m z_j^* \right] \quad (65)$$

where

- U is the thermal transmittance of the insulated plane element before correction, calculated according to 4.1.4.2;
- z is the correction term for irregular insulation-related thermal bridges;
- z^* is the correction term for installation-related thermal bridges.

The correction, $\Delta U_{B,l}$, to allow for the additional heat transfer due to thermal bridges in industrial installations with pipes shall be calculated using Equation (66):

$$\Delta U_{B,l} = U_l \left[\sum_{j=1}^n y_j + \sum_{j=1}^m y_j^* \right] \quad (66)$$

where

- U_l is the linear thermal transmittance of the insulated pipe before correction, calculated according to 4.1.4.2;
- y is the correction term for linear thermal transmittance caused by irregular insulation-related thermal bridges;
- y^* is the correction term for linear thermal transmittance caused by installation related to singular points.

The correction terms, z and z^* or y and y^* , depend on the size of the heat flow rate via the thermal bridge and the frequency of occurrence of the thermal bridges in the industrial installation. They shall, therefore, be specially determined as required for each industrial installation in accordance with 7.2 and 7.3, and identified separately as

- irregular insulation-related thermal bridges (z or y), or
- installation-related thermal bridges (z^* or y^*).

The correction, $\Delta U_{B,sph}$, to allow for the additional heat transfer due to thermal bridges in an industrial installation with hollow spheres, shall be calculated in accordance with ISO 10211.

7.2 Calculation of correction terms for plane surfaces

The thermal transmittance, U_B , of thermal bridges should be calculated in accordance with ISO 10211. Alternatively, the simplified method given in Annex B may be used. The thermal bridges can result from irregular insulation or from the geometrical characteristics of the installation (see Annex B).

If the thermal transmittance for the thermal bridge is known, the correction terms, z or z^* , shall be determined from Equations (67) and (68):

$$z = \frac{U_B A_B}{U A} n \quad (67)$$

$$z^* = \frac{U_B A_B}{U A} n \quad (68)$$

where

- U_B is the thermal transmittance of the thermal bridge, expressed in watts per square metre kelvin;
- A_B is the area of cross-section of the thermal bridge, expressed in square metres;
- n is the number of thermal bridges;
- A is the total heat transfer area of the plane walls of the industrial installation, expressed in square metres.

7.3 Calculation of correction terms for pipes

The thermal transmittance, U_B , of thermal bridges shall be calculated by using numerical methods. The thermal bridges can result from irregular insulation or from the geometrical characteristics of the installation (see Annex B).

If the thermal transmittance, U_B , for the thermal bridge is known, the correction terms, y or y^* , shall be determined from Equations (69) and (70):

$$y = \frac{U_B A_B}{U_1 l} n \quad (69)$$

$$y^* = \frac{U_B A_B}{U_1 l} n \quad (70)$$

where

- U_B is the thermal transmittance of the thermal bridge, expressed in watts per square metre kelvin;
- A_B is the area of cross-section of the thermal bridge, expressed in square metres;

n is the number of thermal bridges;

l is the total pipe length, in metres.

Alternatively, if the thermal bridge is characterized by an equivalent length, Δl , Equations (71) and (72) apply:

$$y = \frac{\Delta l}{l} n \quad (71)$$

$$y^* = \frac{\Delta l}{l} n \quad (72)$$

Equivalent lengths, Δl , for flanges and armatures and estimated values of z^* for pipe suspensions are given in Annex A.

8 Underground pipelines

8.1 General

Pipelines are laid in the ground with or without thermal insulation, either in channels or directly in the soil.

8.2 Calculation of heat loss (single line) without channels

8.2.1 Uninsulated pipe

The heat flow rate per metre, $q_{l,E}$, for a single underground pipe is calculated by Equation (73):

$$q_{l,E} = \frac{\theta_i - \theta_{sE}}{R'_i + R_E} \quad (73)$$

where

θ_i is the medium temperature;

θ_{sE} is the surface temperature of the soil;

R'_i is the linear thermal resistance of the insulation;

R_E is the linear thermal resistance of the ground for a pipe laid in homogeneous soil;

λ_E is the design thermal conductivity of the ambient soil;

H_E is the distance between the centre of the pipe and the ground surface.

The linear thermal resistance of the ground for an uninsulated pipe, as shown in Figure 11, is given by Equation (74):

$$R_E = \frac{1}{2\pi\lambda_E} \operatorname{arcosh} \frac{2H_E}{D_i} \quad (74)$$

which, for $H_E/D_i > 2$, may be simplified to Equation (75):

$$R_E = \frac{1}{2\pi\lambda_E} \ln \frac{4H_E}{D_i} \quad (75)$$

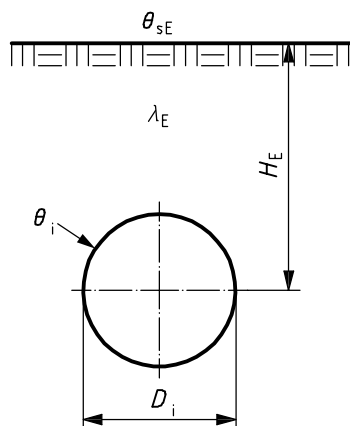
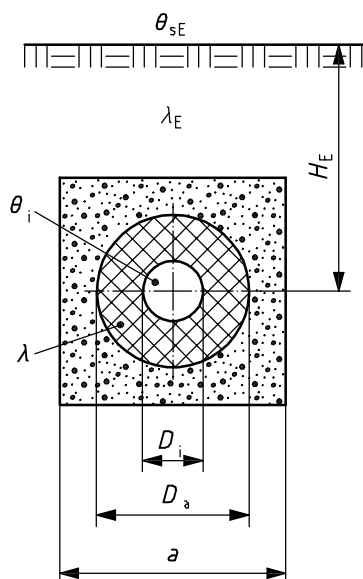

Figure 11 — Underground pipe without insulation

8.2.2 Insulated pipe

For underground pipes with insulating layers, as shown in Figure 12, the thermal resistance is calculated by Equation (76):

$$R'_i = \frac{1}{2\pi} \sum_{j=1}^n \left(\frac{1}{\lambda_j} \ln \frac{D_{ej}}{D_{ij}} \right) \quad (76)$$



NOTE The concentric layers can consist of, for example, insulating material and sheathing (e.g. jacket pipe) embedded in a bottoming (e.g. sand) with a square cross-section.

Figure 12 — Underground pipe comprising several concentric layers

The square cross-section of the outer layer with side length, a , is taken into consideration with an equivalent diameter as given by Equation (77):

$$D_n = 1,073 \times a \quad (77)$$

The internal diameter, D_i , is identical to D_0 (where $j = 1$). The linear thermal resistance of the ground, R_E , becomes, in this case, as given by Equation (78):

$$R_E = \frac{1}{2 \pi \lambda_E} \operatorname{arcosh} \frac{2 H_E}{D_n} \quad (78)$$

which, for $H_E/D_n > 2$, may be simplified to Equation (79):

$$R_E = \frac{1}{2 \pi \lambda_E} \ln \frac{4 H_E}{D_n} \quad (79)$$

8.3 Other cases

Calculation methods are available for the determination of the heat flow rate and temperature field in the ground for several adjacent pipes, i.e. double lines or laid systems; see References [12] and [13].

In the case of commonly used jacket pipes that are laid adjacent to each other, if $\lambda_1 \ll \lambda_E$, calculation as a single pipe is generally sufficient as an initial approach, as heat interchange between the pipes can be disregarded.

Simplified calculation is not permissible for pipes embedded in insulating masses without additional insulation.

Annex A (normative)

Thermal bridges in pipe insulation

The additional heat transfer, represented by ΔU_B , shall be calculated in accordance with ISO 10211 for thermal bridges, such as the following, related to irregular insulation:

- bearing and support structure for pipe coverings, vessels and boilers;
- separate, spring-mounted web;
- through web made from flat steel or round bar;
- other fixings.

Tabulated values of ΔU_B may be used when existing and relevant.

For installation-related thermal bridges, such as flanges, fittings and pipe suspensions, ΔU_B shall be assessed by an increase in the pipe length called equivalent length Δl .

The equivalent length, Δl , for some common cases is given in Table A.1. Table A.1 shows that severe energy losses are incurred by not insulating fittings. Normally, they should be insulated for energy conservation and safety reasons. To be on the safe side, use the highest value.

Table A.1 — Equivalent length for installation-related “thermal bridges”

Flanges for pressure stages PN 25 to PN 100 ^b			Equivalent length for given temperatures ^a		
			Δl m		
			100 °C	250 °C	450 °C
Uninsulated for pipes	in buildings at 20 °C	DN 50 ^c	3 to 5	5 to 11	9 to 15
		DN 100	4 to 7	7 to 16	13 to 16
		DN 150	4 to 9	7 to 17	17 to 30
		DN 200	5 to 11	10 to 26	20 to 37
		DN 300	6 to 16	12 to 37	25 to 57
		DN 400	9 to 16	15 to 36	33 to 56
		DN 500	10 to 16	17 to 36	37 to 57
	in the open air at 0 °C	DN 50	7 to 11	9 to 16	12 to 19
		DN 100	9 to 14	13 to 23	18 to 28
		DN 150	11 to 18	14 to 29	22 to 37
		DN 200	13 to 24	18 to 38	27 to 46
		DN 300	16 to 32	21 to 54	32 to 69
		DN 400	22 to 31	28 to 53	44 to 68
		DN 500	25 to 32	31 to 52	48 to 69
Insulated	in buildings at 20 °C and in the open air at 0 °C	DN 50 ^c	0,7 to 1,0	0,7 to 1,0	1,0 to 1,1
		DN 100	0,7 to 1,0	0,8 to 1,2	1,1 to 1,4
		DN 150	0,8 to 1,1	0,8 to 1,3	1,3 to 1,6
		DN 200	0,8 to 1,3	0,9 to 1,4	1,3 to 1,7
		DN 300	0,8 to 1,4	1,0 to 1,6	1,4 to 1,9
		DN 400	1,0 to 1,4	1,1 to 1,6	1,6 to 1,9
		DN 500	1,1 to 1,3	1,1 to 1,6	1,6 to 1,8
Uninsulated for pipes	in buildings at 20 °C	DN 50	9 to 15	16 to 29	27 to 39
		DN 100	15 to 21	24 to 46	42 to 63
		DN 150	1 to 28	26 to 63	58 to 90
		DN 200	21 to 35	37 to 82	73 to 108
		DN 300	29 to 51	50 to 116	106 to 177
		DN 400	36 to 60	59 to 136	126 to 206
		DN 500	46 to 76	75 to 170	158 to 267
	in the open air at 0 °C only for pressure stage PN 25	DN 50	22 to 24	27 to 34	35 to 39
		DN 100	33 to 36	42 to 52	56 to 61
		DN 150	39 to 42	50 to 68	77 to 83
		DN 200	51 to 56	68 to 87	98 to 101
		DN 300	59 to 75	90 to 125	140 to 160
		DN 400	84 to 88	106 to 147	165 to 190
		DN 500	108 to 114	134 to 182	205 to 238

Table A.1 (continued)

Fittings for pressure stages PN 25 to PN 100 ^b			Equivalent length for given temperatures ^a		
			Δl m		
			100 °C	250 °C	450 °C
Insulated for pipes	in buildings at 20 °C and in the open air at 0 °C	DN 50 ^c	4 to 5	5 to 6	6 to 7
		DN 100	4 to 5	5 to 7	6 to 7
		DN 150	4 to 6	5 to 8	6 to 9
		DN 200	5 to 7	5 to 9	7 to 10
		DN 300	5 to 9	6 to 12	7 to 13
		DN 400	6 to 9	7 to 12	8 to 15
		DN 500	7 to 11	8 to 15	9 to 19
Pipe suspensions			Supplementary value		
			y^*		
In buildings			0,15		
In the open air			0,25		
<p>^a The ranges given cover the effects of the temperature and of the pressure stages. Flanges and fittings for higher pressure stages give higher values.</p> <p>^b PN is the nominal pressure.</p> <p>^c DN is the nominal diameter.</p>					

Annex B (informative)

Projecting thermal bridges of roughly constant cross-section

B.1 General

A metal fin of roughly constant cross-section, which may be surrounded by an insulating layer (see Figure B.1), has at the fin base the temperature, θ_b , of the wall and releases heat to the environment at temperature θ_a .

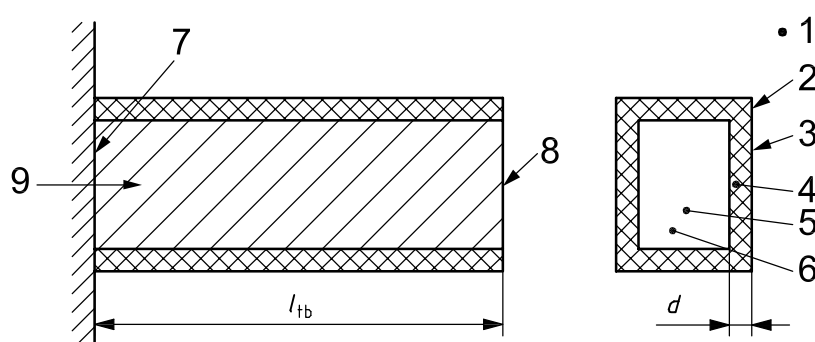

Key

- 1 point of measurement of the ambient temperature, θ_a , expressed in degrees Celsius
- 2 point of measurement for calculating the surface coefficient of heat transfer, h , expressed in watts per square metre kelvin
- 3 point of measurement of the perimeter, P , expressed in metres
- 4 point of measurement for calculating the design thermal conductivity of the insulation, λ , expressed in watts per metre kelvin
- 5 cross-sectional area of the thermal bridge, A_{tb} , expressed in square metres
- 6 point of measurement for calculating the design thermal conductivity of the thermal bridge material, λ_{tb} , expressed in watts per metre kelvin
- 7 point of measurement of the temperature of the thermal bridge base, θ_b , expressed in degrees Celsius
- 8 point of measurement for calculating the thermal transmittance on the frontal of the thermal bridge, U_{fa} , expressed in watts per square metre kelvin
- 9 heat flow, Φ , expressed in watts
- l_{tb} length of the thermal bridge, expressed in metres
- d thickness of the insulation, expressed in metres

Figure B.1 — Mountings (designations)

The thermal transmittance of the thermal bridge, U_{tb} , related to the area of the cross-section, A_{tb} , of the thermal bridge is given by Equation (B.1):

$$U_{tb} = \frac{\lambda_{tb} k}{l_{tb}} \quad (\text{B.1})$$

The dimensionless factor, k , can be calculated from Equation (B.2) or determined by using Figure B.2 after having calculated the dimensionless parameters B and B_{fa} using Equations (B.3) and (B.4):

$$k = B \frac{B \sinh B + B_{fa} \cosh B}{B \cosh B + B_{fa} \sinh B} \quad (\text{B.2})$$

where

$$\cosh B = \frac{e^B + e^{-B}}{2}$$

$$\sinh B = \frac{e^B - e^{-B}}{2}$$

$$B = l_{tb} \sqrt{\frac{P}{\lambda_{tb} A_{tb} \left(\frac{1}{h} + \frac{d}{\lambda} \right)}} \quad (\text{B.3})$$

$$B_{fa} = \frac{U_{fa} l_{tb}}{\lambda} \quad (\text{B.4})$$

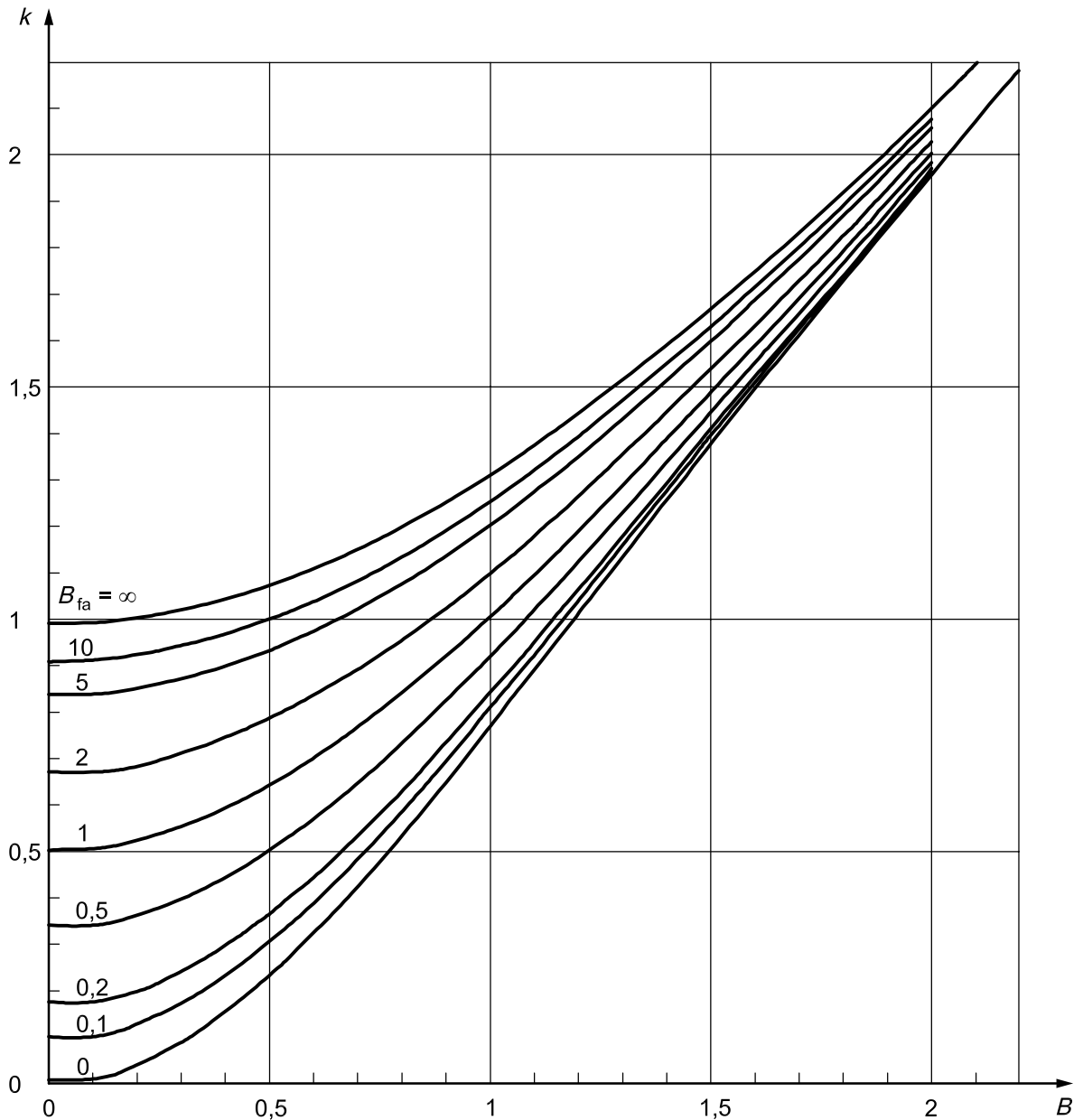
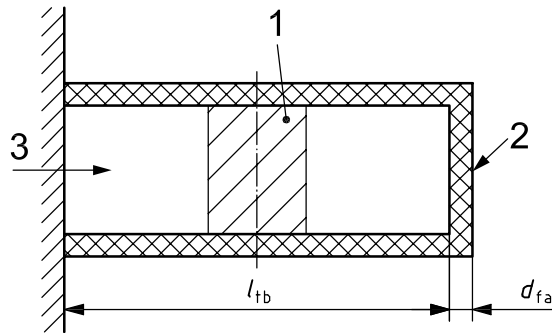

Figure B.2 — Factor k for the calculation of the heat transfer of projecting thermal bridges

The external surface coefficient, h_{se} , can be calculated in accordance with 4.1.3, while the thermal transmittance, U_{fa} , on the frontal area can be assessed for each case in Clauses B.2 to B.4.

B.2 Insulated or free frontal area



Key

- 1 area of the cross-section of the thermal bridge, A_{tb} , expressed in square metres
- 2 point of measurement for calculating the heat transfer coefficient, h , expressed in watts per square metre kelvin
- 3 heat flow, Φ , expressed in watts
- d_{fa} thickness of the insulation on the frontal area, expressed in metres
- l_{tb} (See Figure B.1.)

Figure B.3 — Mounting with insulated or free frontal area

The insulated frontal area can be calculated from Equation (B.5):

$$\frac{1}{U_{fa}} = \frac{d_{fa}}{\lambda} + \frac{1}{h} \tag{B.5}$$

The free frontal area can be calculated from Equation (B.6):

$$U_{fa} = h \tag{B.6}$$

B.3 Anchoring structure

An anchoring structure of any desired shape, made from material that has good conducting properties and is based in the ground or in concrete, is attached to the frontal area (see Figure B.4).

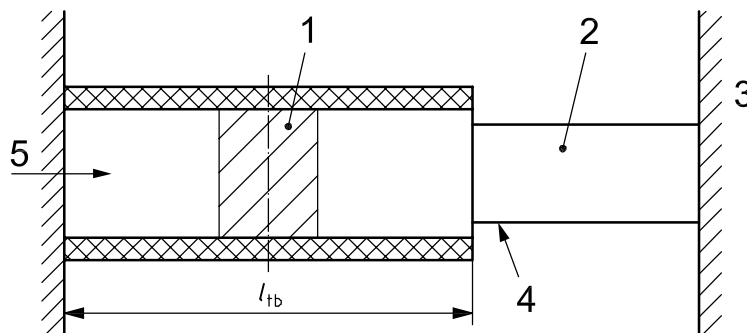

Key

- 1 area of the cross-section of the thermal bridge, A_{tb} , expressed in square metres
- 2 area of the surface of the anchorage, A_a , expressed in square metres
- 3 concrete or ground
- 4 point of measurement for calculating the heat transfer coefficient, h , expressed in watts per square metre kelvin
- 5 heat flow, Φ , expressed in watts

Figure B.4 — Mounting with anchorage, e.g. in ground

If A_a is the total surface of the anchoring structure, the maximum value for U_{fa} can be assessed by Equation (B.7):

$$U_{fa} = \frac{A_a h}{A_{tb}} \quad (\text{B.7})$$

Where the shaping of the connecting structure permits it, the latter can itself be considered in turn as a fin, and the heat flow on the interface between the two fins and the resulting value of U_{fa} can be calculated in accordance with Equation (B.8).

B.4 Fin frontal area is in good heat contact with free metal supports

The rough estimate given by Equation (B.7) applies here:

$$1/U_{fa} = 0 \quad (\text{B.8})$$

For geometries with widely varying cross-section, a calculation using numerical methods is recommended.

Annex C (informative)

Examples

C.1 Calculation of the necessary insulation thicknesses for a double-layered wall of a firebox

The conditions for this example are the following:

- inside temperature: $\theta_i = 850 \text{ }^\circ\text{C}$;
- outside temperature: $\theta_e = 20 \text{ }^\circ\text{C}$;
- height of the wall: $H = 4 \text{ m}$;
- maximum density of heat flow rate: $q = 500 \text{ W/m}^2$;
- air velocity: $v = 3 \text{ m/s}$;
- insulation consisting of the following materials:
 - first layer of aluminium silicate fibre,
 - second layer of mineral wool with a galvanized sheet iron lining;
- temperature at the boundary layers: $\theta_j = 600 \text{ }^\circ\text{C}$.

Neglecting the inner surface resistance, the insulation thickness, d_1 , of the first layer can be found using a rearranged form of Equation (2) with a design thermal conductivity $\lambda_1 = 0,20 \text{ W/(m}\cdot\text{K)}$ at $\theta_{av} = 725 \text{ }^\circ\text{C}$, as given in Equation (C.1).

$$d_1 = 0,20 \times \frac{850 - 600}{500} = 0,10 \text{ m} \quad (\text{C.1})$$

To calculate the required thickness of the second insulation layer, d_2 , it is necessary first to calculate the external surface coefficient, h_{se} , based on Equations (17), (18) and (27) and an estimate of the external surface temperature of $\theta_{se} = 60 \text{ }^\circ\text{C}$.

The temperature factor, a_r , is calculated as given in Equation (C.2):

$$a_r = 4 \times 313,15^3 = 1,23 \times 10^8 \text{ K}^3 \quad (\text{C.2})$$

Then, for $C_r = 1,47 \times 10^{-8} \text{ W/(m}^2\cdot\text{K}^4)$, which is equivalent to $\varepsilon = 0,26$, the value h_r is calculated by Equation (C.3):

$$h_r = a_r \times C_r = 1,23 \times 10^8 \times 1,47 \times 10^{-8} = 1,81 \text{ W/(m}^2\cdot\text{K)} \quad (\text{C.3})$$

The convective term, h_{cv} , calculated based on Equation (27), is given by Equation (C.4):

$$h_{cv} = 5,76 \times \sqrt[5]{\frac{3^4}{4}} = 10,5 \text{ W}/(\text{m}^2 \cdot \text{K}) \quad (\text{C.4})$$

The total external surface coefficient, h_{se} , is equal to 12,31 W/(m²·K).

The declared thermal conductivity for the second layer of the mineral wool at $\theta_{av} = 330 \text{ °C}$ is $\lambda_d = 0,110 \text{ W}/(\text{m} \cdot \text{K})$, to which it is necessary to add an additional term for steel supports, $\Delta\lambda = 0,010 \text{ W}/(\text{m} \cdot \text{K})$ (see Clause 7), yielding a value for λ_2 of 0,120 W/(m·K).

Using again Equation (2) in the form given by Equation (C.5):

$$q = \frac{\theta_i - \theta_e}{\frac{d_2}{\lambda_2} + \frac{1}{h_{se}}} \quad (\text{C.5})$$

the necessary insulation thickness, d_2 , of the second layer is given by a simple mathematical transformation, as given in Equation (C.6):

$$d_2 = 0,120 \times \left(\frac{600 - 20}{500} - \frac{1}{12,31} \right) = 0,130 \text{ m} \quad (\text{C.6})$$

The density of heat flow rate can be checked based on Equation (35), as given in Equation (C.7):

$$q = \frac{850 - 20}{\frac{0,10}{0,20} + \frac{0,130}{0,120} + \frac{1}{12,31}} = 499 \text{ W}/\text{m}^2 \quad (\text{C.7})$$

The calculation of the temperature distribution based on Equations (45) to (48) leads to a joint temperature at the boundary layer of $\theta_j = 600,5 \text{ °C}$ and an external surface temperature $\theta_{se} = 59,9 \text{ °C}$, which is in a good agreement with the above assumption.

C.2 Density of heat flow rate and surface temperature of an insulated pipe

The density of heat flow rate and the external surface temperature for an insulated, hot-air supply pipe with a dusty sheet iron lining are calculated for the following data:

- medium temperature (air): $\theta_i = 300 \text{ °C}$;
- ambient air temperature: $\theta_a = 20 \text{ °C}$;
- pipe diameter: $D_i = 0,324 \text{ m}$;
- insulation thickness: $d = 0,200 \text{ m}$;
- design thermal conductivity of the insulation at $\theta = 165 \text{ °C}$: $\lambda = 0,062 \text{ W}/(\text{m} \cdot \text{K})$;
- radiation coefficient of the sheet iron lining of the insulation: $C_r = 2,49 \text{ W}/(\text{m}^2 \cdot \text{K})$;
- outer pipe diameter, $D_e = D_i + 2d$: $D_e = 0,724 \text{ m}$.

It is necessary to increase the declared thermal conductivity, λ_d , of the insulation material by $\Delta\lambda = 0,01 \text{ W/(m}\cdot\text{K)}$ in accordance with Clause 7, as given in Equation (C.8):

$$\lambda_d = 0,062 + 0,01 = 0,072 \text{ W/(m}\cdot\text{K)} \quad (\text{C.8})$$

Based on Equation (30), the external surface coefficient, h_{se} , can be calculated with an estimated surface temperature, θ_{se} , equal to $30 \text{ }^\circ\text{C}$, as given in Equation (C.9).

$$h_{se} = 5,30 + 0,05 \times (30 - 20) = 5,8 \text{ W/(m}^2\cdot\text{K)} \quad (\text{C.9})$$

The inner surface resistance is neglected. The linear density of heat flow rate, q_l , is then calculated based on Equation (35), into which Equations (6) and (37) have been substituted, as given in Equation (C.10):

$$q_l = \frac{\pi \times (300 - 20)}{\frac{1}{2 \times 0,072} \times \ln\left(\frac{0,724}{0,324}\right) + \frac{1}{5,8 \cdot 0,724}} = 151,1 \text{ W/m} \quad (\text{C.10})$$

The external surface temperature, θ_{se} , is then found based on Equation (48), as given in Equation (C.11):

$$\theta_{se} = 20 + \frac{0,24}{5,8} \times (300 - 20) = 31,6 \text{ }^\circ\text{C} \quad (\text{C.11})$$

This is in good agreement with the above assumption of $30 \text{ }^\circ\text{C}$.

C.3 Temperature drop in a pipe

The longitudinal temperature drop of a hot steam pipe is calculated for the following data:

- temperature of the medium (hot steam): $\theta_{im} = 250 \text{ }^\circ\text{C}$;
- mass flow rate of the medium: $\dot{m} = 45\,000 \text{ kg/h}$;
- specific heat capacity: $c_p = 2,233 \text{ kJ/(kg}\cdot\text{K)}$;
- ambient air temperature: $\theta_a = -10 \text{ }^\circ\text{C}$;
- pipe diameter: $D_i = 0,40 \text{ m}$;
- pipe length: $l = 2\,500 \text{ m}$;
- insulation thickness: $d = 0,12 \text{ m}$;
- thermal conductivity of the insulation (design value) at $\theta_{av} = 120 \text{ }^\circ\text{C}$: $\lambda = 0,061 \text{ W/(m}\cdot\text{K)}$;
- outer pipe diameter, $D_e = D_i + 2d$: $D_e = 0,64 \text{ m}$.

The inner and outer surface resistances are neglected in this example. This gives a linear density of heat flow rate, q_l , based on Equations (6) and (7), of 212 W/m .

Substituting this value into Equation (56) gives an approximate longitudinal temperature drop according to Equation (C.12):

$$\Delta\theta = \frac{212 \times 2\,500 \times 3,6}{45\,000 \times 2,233} = 19,0 \text{ }^\circ\text{C} \quad (\text{C.12})$$

The accurate temperature drop is calculated using Equations (54) and (55), which then permits the calculation of θ_{fm} as given by Equation (C.13):

$$\theta_{fm} = -10 + |250 + 10| \times \exp - (2,9 \times 10^{-5} \times 2\,500) = 231,8 \text{ } ^\circ\text{C} \quad (\text{C.13})$$

Therefore, the accurate temperature drop, $\Delta\theta$, is as given in Equation (C.14):

$$\Delta\theta = \theta_{im} - \theta_{fm} = 250 - 231,8 = 18,2 \text{ } ^\circ\text{C} \quad (\text{C.14})$$

C.4 Temperature drop in a container

The temperature drop of a spherical hot water supply container over 15 h is calculated for the following data:

- temperature of the medium (hot water): $\theta_{im} = 80 \text{ } ^\circ\text{C}$;
- specific heat capacity: $c_p = 4,18 \text{ kJ}/(\text{kg}\cdot\text{K})$;
- ambient air temperature: $\theta_a = -15 \text{ } ^\circ\text{C}$;
- sphere diameter: $D_i = 2,50 \text{ m}$;
- corresponding mass of water: $m = 818 \text{ kg}$;
- insulation thickness: $d = 0,15 \text{ m}$;
- thermal conductivity of the insulation (design value) at $\theta_{av} = 30 \text{ } ^\circ\text{C}$: $\lambda = 0,05 \text{ W}/(\text{m}\cdot\text{K})$;
- outer sphere diameter, $D_e = D_i + 2d$: $D_e = 2,8 \text{ m}$.

The inner and outer surface resistances are neglected in this example. The heat flow rate, Φ_{sph} , can be calculated based on Equations (10) and (11), as given in Equation (C.15):

$$\Phi_{\text{sph}} = \frac{80 + 15}{\frac{1}{2 \times \pi \times 0,05} \times \left(\frac{1}{2,5} - \frac{1}{2,8} \right)} = 696 \text{ W} \quad (\text{C.15})$$

Substituting this value into Equation (56) gives an approximate temperature drop as given in Equation (C.16):

$$\Delta\theta = \frac{696}{8\,181 \times 4,18} \times 15 \times 3,6 = 1,1 \text{ } ^\circ\text{C} \quad (\text{C.16})$$

The accurate temperature drop is calculated based on Equations (54) and (55), with θ_{fm} and θ_{im} being the temperatures at the start and the end of the cooling period, respectively, as given by Equation (C.17):

$$\begin{aligned} \theta_{fm} &= -15 + (80 + 15) \times \exp\left(-\frac{1,1}{80 + 15}\right) \\ &= 78,9 \text{ } ^\circ\text{C} \end{aligned} \quad (\text{C.17})$$

Therefore, the accurate temperature drop is as given in Equation (C.18):

$$\begin{aligned} \Delta\theta &= \theta_{im} - \theta_{fm} \\ &= 80 - 78,9 \\ &= 1,1 \text{ } ^\circ\text{C} \end{aligned} \quad (\text{C.18})$$

C.5 Cooling and freezing times in a pipe

The time to cool down to 0 °C and the time for the partial freezing of the water (25 % of the volume) are calculated for the following data:

- interior pipe diameter: $D_{ip} = 0,090 \text{ m};$
- interior insulation diameter: $D_i = 0,1079 \text{ m};$
- water temperature at the start of cooling: $\theta_{im} = +10 \text{ }^\circ\text{C};$
- ambient temperature: $\theta_a = -10 \text{ }^\circ\text{C};$
- insulation thickness: $d = 0,100 \text{ m};$
- design thermal conductivity: $\lambda = 0,04 \text{ W}/(\text{m}\cdot\text{K});$
- heat capacity of water: $m c_{pw} = 26,7 \text{ kJ}/\text{K};$
- latent heat of freezing: $h_{fr} = 334 \text{ kJ}/\text{kg};$
- specific heat capacity of water: $c_{pw} = 4,2 \text{ kJ}/(\text{kg}\cdot\text{K});$
- density of ice: $\rho_{ice} = 920 \text{ kg}/\text{m}^3.$

The total heat flow rate per meter, Φ_T , is calculated based on Equation (52), neglecting the surface coefficient, h_{se} , as given in Equation (C.19):

$$\Phi_T = \frac{\pi \times [10 - (-10)]}{\frac{1}{2 \times 0,04} \times \ln\left(\frac{0,3079}{0,1079}\right)} \times 1 = 4,79 \text{ W} \quad (\text{C.19})$$

The corresponding time to cool down to the freezing point, neglecting the heat capacity of the pipe, can be calculated either based on Equation (60) as given by Equation (C.20), or based on Equation (62) as given by Equation (C.21):

$$t_{wp} = \frac{20 \times 26,7 \times \ln\left(\frac{20}{10}\right)}{4,79 \times 3,6 \times 1} = 21,5 \text{ h} \quad (\text{C.20})$$

$$t_{wp} = \frac{26,7 \times 10}{4,79 \times 3,6 \times 1} = 15,5 \text{ h} \quad (\text{C.21})$$

The heat flow rate per metre and the time for freezing of 25 % of the volume of the pipe, based on Equations (64) and (63), are given by Equations (C.22) and (C.23), respectively:

$$\Phi_{T,fr} = \frac{\pi \times 10}{\frac{1}{0,08} \times \ln\left(\frac{0,3079}{0,1079}\right)} \times 1 = 2,40 \text{ W} \quad (\text{C.22})$$

$$t_{fr} = \frac{25}{100} \times \frac{920 \times \pi \times (0,09)^2 \times 334}{2,4 \times 3,6 \times 4} = 56,6 \text{ h} \quad (\text{C.23})$$

C.6 Underground pipeline

The density of heat flow rate of an insulated underground metal pipeline protected by an outer polyethylene pipe is calculated for the following data:

- external diameter of metal pipe: $D_e = 0,219\ 1\ \text{m}$;
- depth below surface: $H_E = 1,0\ \text{m}$;
- insulation thickness: $d = 0,061\ \text{m}$;
- design thermal conductivity at 55 °C: $\lambda = 0,028\ \text{W}/(\text{m}\cdot\text{K})$;
- PE pipe internal diameter: $D_i = 0,341\ \text{m}$;
- thickness: $d_{PE} = 0,007\ \text{m}$;
- temperature of the soil: $\theta_{se} = 3\ \text{°C}$;
- design thermal conductivity of the soil: $\lambda = 1,75\ \text{W}/(\text{m}\cdot\text{K})$;
- temperature of the medium: $\theta_{im} = 100\ \text{°C}$.

The linear density of heat flow rate, based on Equations (73), (75) and (76), is as given by Equation (C.24):

$$q_l = \frac{\pi(100 - 3)}{\frac{1}{2 \times 1,75} \times \ln\left(\frac{4 \times 1}{0,355}\right) + \frac{1}{2 \times 0,028} \times \ln\left(\frac{0,341}{0,219\ 1}\right)} = 35,5\ \text{W/m} \quad (\text{C.24})$$

The temperature difference between the PE pipe surface and the surrounding soil, as specified in 4.1.5, is as given by Equation (C.25):

$$\Delta\theta = \frac{35,5}{\pi} \times \frac{1}{2 \times 1,75} \times \ln\left(\frac{4 \times 1}{0,355}\right) = 7,8\ \text{K} \quad (\text{C.25})$$

Thus, the temperature, θ_{se} , of the PE pipe surface is as given by Equation (C.26):

$$\theta_{se} = 3,0 + 7,8 = 10,8\ \text{°C} \quad (\text{C.26})$$

C.7 Required insulation thickness to prevent surface condensation

The insulation thickness necessary to prevent dew formation on the surface of the thermal insulation material with a galvanized sheet metal cladding of a refrigerant pipe is calculated for the following data:

- temperature of the medium: $\theta_{im} = -20\ \text{°C}$;
- ambient air temperature: $\theta_a = 20\ \text{°C}$;
- pipe diameter without insulation: $D_i = 0,273\ \text{m}$;
- relative humidity of the ambient air: $\varphi = 90\ \%$.

Table 4 gives an allowed maximum temperature difference of 1,7 K; hence, θ_{se} is equal to 18,3 °C.

The design thermal conductivity, λ , of the insulation is equal to 0,039 W/(m·K), when θ_{av} is as given in Equation (C.27):

$$\begin{aligned}\theta_{av} &= (-20 + 18,3)/2 = -0,85 \text{ °C} \\ &= -0,85 \text{ °C}\end{aligned}\tag{C.27}$$

The external surface coefficient can be estimated, based on Equation (30), as given in Equation (C.28):

$$h_{se} = 5,3 + 0,05 \times 1,7 = 5,39 \text{ W/(m}^2\cdot\text{K)}\tag{C.28}$$

This value can be used to calculate the parameter, C' , from Figure 9, based on Equation (50), as given in Equation (C.29):

$$C' = \frac{2 \times 0,039}{5,39} \times \left[\frac{(-20 - 20)}{18,3 - 20} - 1 \right] = 0,326\tag{C.29}$$

The necessary insulation thickness can be determined directly from Figure 9.

The value for the thickness seems to be slightly higher than 120 mm; thus, the value of d chosen is 125 mm.

The condensation control calculation is made, starting with Equation (7), which gives the linear thermal resistance of the insulation, R_i , of 2,65 (m·K)/W. The linear thermal surface resistance, R_{ie} equals 0,113 (m·K)/W, calculated on the basis of Equation (33) with $h_{se} = 5,39 \text{ W/(m}^2\cdot\text{K)}$. Then, the surface temperature, θ_{se} , can be calculated based on Equation (48), as given by Equation (C.30):

$$\theta_{se} = 20 + \frac{0,113}{0,113 + 2,65} \times (-20 - 20) = 18,37 \text{ °C}\tag{C.30}$$

The resulting value is higher than the allowed minimum temperature of the pipe surface and, hence, prevents dew formation.

Bibliography

- [1] ISO 8301:1991, *Thermal insulation — Determination of steady-state thermal resistance and related properties — Heat flow meter apparatus*
- [2] ISO 8302:1991, *Thermal insulation — Determination of steady-state thermal resistance and related properties — Guarded hot plate apparatus*
- [3] ISO 8497:1994, *Thermal insulation — Determination of steady-state thermal transmission properties of thermal insulation for circular pipes*
- [4] ISO 9229:2007, *Thermal insulation — Vocabulary*
- [5] ISO 9251:1987, *Thermal insulation — Heat transfer conditions and properties of materials — Vocabulary*
- [6] ISO 9288:1989, *Thermal insulation — Heat transfer by radiation — Physical quantities and definitions*
- [7] ASTM C 680, *Standard practice for estimate of the heat gain or loss and the surface temperatures of insulated flat, cylindrical, and spherical systems by use of computer programs*
- [8] *Standard international units of the international Union for pure and applied physics (IUPAP)*; Document SUN 75-5
- [9] VDI 2055-1:2006, *Thermal insulation of heated and refrigerated operational installations in the industry and the technical building equipment — Part 1: Calculation rules*
- [10] BS 5422:2001, *Method for specifying thermal insulating materials for pipes, tanks, vessels, ductwork and equipment operating within the temperature range – 40 °C to + 700 °C*
- [11] VIDAL, J., *Determination of heat losses in underground conduits*, Brussels: Editions SIC, 1961
- [12] BRAUER, H., Calculation of heat losses from underground pipes, *Energie*, **15**(1963), No. 9, pp. 354–365
- [13] ZEITLER, M., Calculation method for determining heat loss from various underground pipe systems. *Fernwärme International*, No. 3(1980), pp. 170–179

BSI - British Standards Institution

BSI is the independent national body responsible for preparing British Standards. It presents the UK view on standards in Europe and at the international level. It is incorporated by Royal Charter.

Revisions

British Standards are updated by amendment or revision. Users of British Standards should make sure that they possess the latest amendments or editions.

It is the constant aim of BSI to improve the quality of our products and services. We would be grateful if anyone finding an inaccuracy or ambiguity while using this British Standard would inform the Secretary of the technical committee responsible, the identity of which can be found on the inside front cover. Tel: +44 (0)20 8996 9000. Fax: +44 (0)20 8996 7400.

BSI offers members an individual updating service called PLUS which ensures that subscribers automatically receive the latest editions of standards.

Buying standards

Orders for all BSI, international and foreign standards publications should be addressed to Customer Services. Tel: +44 (0)20 8996 9001. Fax: +44 (0)20 8996 7001 Email: orders@bsigroup.com You may also buy directly using a debit/credit card from the BSI Shop on the Website <http://www.bsigroup.com/shop>

In response to orders for international standards, it is BSI policy to supply the BSI implementation of those that have been published as British Standards, unless otherwise requested.

Information on standards

BSI provides a wide range of information on national, European and international standards through its Library and its Technical Help to Exporters Service. Various BSI electronic information services are also available which give details on all its products and services. Contact Information Centre. Tel: +44 (0)20 8996 7111 Fax: +44 (0)20 8996 7048 Email: info@bsigroup.com

Subscribing members of BSI are kept up to date with standards developments and receive substantial discounts on the purchase price of standards. For details of these and other benefits contact Membership Administration. Tel: +44 (0)20 8996 7002 Fax: +44 (0)20 8996 7001 Email: membership@bsigroup.com

Information regarding online access to British Standards via British Standards Online can be found at <http://www.bsigroup.com/BSOL>

Further information about BSI is available on the BSI website at <http://www.bsigroup.com>.

Copyright

Copyright subsists in all BSI publications. BSI also holds the copyright, in the UK, of the publications of the international standardization bodies. Except as permitted under the Copyright, Designs and Patents Act 1988 no extract may be reproduced, stored in a retrieval system or transmitted in any form or by any means – electronic, photocopying, recording or otherwise – without prior written permission from BSI.

This does not preclude the free use, in the course of implementing the standard, of necessary details such as symbols, and size, type or grade designations. If these details are to be used for any other purpose than implementation then the prior written permission of BSI must be obtained.

Details and advice can be obtained from the Copyright and Licensing Manager. Tel: +44 (0)20 8996 7070 Email: copyright@bsigroup.com