

BS EN ISO 12181-1:2011



BSI Standards Publication

# Geometrical product specifications (GPS) — Roundness

Part 1: Vocabulary and parameters of roundness

**bsi.**

...making excellence a habit.™

**National foreword**

This British Standard is the UK implementation of EN ISO 12181-1:2011. It supersedes DD CEN ISO/TS 12181-1:2007, which is withdrawn.

The UK participation in its preparation was entrusted to Technical Committee TDW/4, Technical Product Realization.

A list of organizations represented on this committee can be obtained on request to its secretary.

This publication does not purport to include all the necessary provisions of a contract. Users are responsible for its correct application.

© BSI 2011

ISBN 978 0 580 66722 0

ICS 01.040.17; 17.040.20

**Compliance with a British Standard cannot confer immunity from legal obligations.**

This British Standard was published under the authority of the Standards Policy and Strategy Committee on 30 April 2011.

**Amendments issued since publication**

Date	Text affected
------	---------------

---

English Version

Geometrical product specifications (GPS) - Roundness - Part 1:  
Vocabulary and parameters of roundness (ISO 12181-1:2011)

Spécification géométrique des produits (GPS) - Circularité -  
Partie 1: Vocabulaire et paramètres de circularité (ISO  
12181-1:2011)

Geometrische Produktspezifikation (GPS) - Rundheit - Teil  
1: Begriffe und Kenngrößen der Rundheit (ISO 12181-  
1:2011)

This European Standard was approved by CEN on 17 March 2011.

CEN members are bound to comply with the CEN/CENELEC Internal Regulations which stipulate the conditions for giving this European Standard the status of a national standard without any alteration. Up-to-date lists and bibliographical references concerning such national standards may be obtained on application to the CEN-CENELEC Management Centre or to any CEN member.

This European Standard exists in three official versions (English, French, German). A version in any other language made by translation under the responsibility of a CEN member into its own language and notified to the CEN-CENELEC Management Centre has the same status as the official versions.

CEN members are the national standards bodies of Austria, Belgium, Bulgaria, Croatia, Cyprus, Czech Republic, Denmark, Estonia, Finland, France, Germany, Greece, Hungary, Iceland, Ireland, Italy, Latvia, Lithuania, Luxembourg, Malta, Netherlands, Norway, Poland, Portugal, Romania, Slovakia, Slovenia, Spain, Sweden, Switzerland and United Kingdom.



EUROPEAN COMMITTEE FOR STANDARDIZATION  
COMITÉ EUROPÉEN DE NORMALISATION  
EUROPÄISCHES KOMITEE FÜR NORMUNG

Management Centre: Avenue Marnix 17, B-1000 Brussels

## Foreword

This document (EN ISO 12181-1:2011) has been prepared by Technical Committee ISO/TC 213 "Dimensional and geometrical product specifications and verification" in collaboration with Technical Committee CEN/TC 290 "Dimensional and geometrical product specification and verification" the secretariat of which is held by AFNOR.

This European Standard shall be given the status of a national standard, either by publication of an identical text or by endorsement, at the latest by October 2011, and conflicting national standards shall be withdrawn at the latest by October 2011.

Attention is drawn to the possibility that some of the elements of this document may be the subject of patent rights. CEN [and/or CENELEC] shall not be held responsible for identifying any or all such patent rights.

This document supersedes CEN ISO/TS 12181-1:2007.

According to the CEN/CENELEC Internal Regulations, the national standards organizations of the following countries are bound to implement this European Standard: Austria, Belgium, Bulgaria, Croatia, Cyprus, Czech Republic, Denmark, Estonia, Finland, France, Germany, Greece, Hungary, Iceland, Ireland, Italy, Latvia, Lithuania, Luxembourg, Malta, Netherlands, Norway, Poland, Portugal, Romania, Slovakia, Slovenia, Spain, Sweden, Switzerland and the United Kingdom.

### Endorsement notice

The text of ISO 12181-1:2011 has been approved by CEN as a EN ISO 12181-1:2011 without any modification.

<b>Contents</b>		Page
<b>Foreword</b> .....		iv
<b>Introduction</b> .....		v
<b>1</b> <b>Scope</b> .....		1
<b>2</b> <b>Normative references</b> .....		1
<b>3</b> <b>Terms and definitions</b> .....		1
<b>3.1</b> <b>General terms</b> .....		1
<b>3.2</b> <b>Terms relating to profiles</b> .....		2
<b>3.3</b> <b>Terms relating to the reference circle</b> .....		3
<b>3.4</b> <b>Terms relating to the circumference</b> .....		4
<b>3.5</b> <b>Terms relating to the filter function</b> .....		4
<b>3.6</b> <b>Terms relating to parameters</b> .....		5
<b>Annex A</b> (informative) <b>Mathematical definition of roundness tolerances of nominal integral features</b> .....		7
<b>Annex B</b> (informative) <b>Synoptic tables of terms, abbreviated terms and parameters</b> .....		9
<b>Annex C</b> (informative) <b>Relationship to the GPS matrix model</b> .....		11
<b>Bibliography</b> .....		13

## Foreword

ISO (the International Organization for Standardization) is a worldwide federation of national standards bodies (ISO member bodies). The work of preparing International Standards is normally carried out through ISO technical committees. Each member body interested in a subject for which a technical committee has been established has the right to be represented on that committee. International organizations, governmental and non-governmental, in liaison with ISO, also take part in the work. ISO collaborates closely with the International Electrotechnical Commission (IEC) on all matters of electrotechnical standardization.

International Standards are drafted in accordance with the rules given in the ISO/IEC Directives, Part 2.

The main task of technical committees is to prepare International Standards. Draft International Standards adopted by the technical committees are circulated to the member bodies for voting. Publication as an International Standard requires approval by at least 75 % of the member bodies casting a vote.

Attention is drawn to the possibility that some of the elements of this document may be the subject of patent rights. ISO shall not be held responsible for identifying any or all such patent rights.

ISO 12181-1 was prepared by Technical Committee ISO/TC 213, *Dimensional and geometrical product specifications and verification*.

This first edition of ISO 12181-1 cancels and replaces ISO/TS 12181-1:2003, which has been technically revised.

ISO 12181 consists of the following parts, under the general title *Geometrical product specifications (GPS) — Roundness*:

- *Part 1: Vocabulary and parameters of roundness*
- *Part 2: Specification operators*

## Introduction

This part of ISO 12181 is a geometrical product specification (GPS) standard and is to be regarded as a general GPS standard (see ISO/TR 14638). It influences chain link 2 of the chain of standards on form of a surface (independent of a datum).

The ISO/GPS Masterplan given in ISO/TR 14638 gives an overview of the ISO/GPS system of which this document is a part. The fundamental rules of ISO/GPS given in ISO 8015 apply to this document and the default decision rules given in ISO 14253-1 apply to specifications made in accordance with this document, unless otherwise indicated.

For more detailed information on the relationship of this part of ISO 12181 to other standards and the GPS matrix model, see Annex C.

This part of ISO 12181 defines terms and concepts necessary for defining the specification operators according to ISO 17450-2 for roundness of integral features.

Extracting data always involves applying a certain filtering process. An additional filtering of the extracted data might or might not be applied. This additional filter can be a mean line filter (Gaussian, spline, wavelet, etc.) or a non-linear filter (e.g. morphological filter). The type of filtering influences the actual specification operator and, consequently, the actual definition of roundness. Therefore, the type of filtering needs to be stated unambiguously.

This part of ISO 12181 is not intended to disallow any means of measuring roundness.





# Geometrical product specifications (GPS) — Roundness —

## Part 1: Vocabulary and parameters of roundness

### 1 Scope

This part of ISO 12181 defines the terms and concepts related to the roundness of individual integral features and covers complete roundness profiles only.

### 2 Normative references

The following referenced documents are indispensable for the application of this document. For dated references, only the edition cited applies. For undated references, the latest edition of the referenced document (including any amendments) applies.

ISO 14660-1:1999, *Geometrical Product Specifications (GPS) — Geometrical features — Part 1: General terms and definitions*

ISO 14660-2:1999, *Geometrical Product Specifications (GPS) — Geometrical features — Part 2: Extracted median line of a cylinder and a cone, extracted median surface, local size of an extracted feature*

ISO 17450-1:—<sup>1)</sup>, *Geometrical product specifications (GPS) — General concepts — Part 1: Model for geometrical specification and verification*

### 3 Terms and definitions

For the purposes of this document, the terms and definitions given in ISO 14660-1, ISO 14660-2 and ISO 17450-1 and the following apply.

#### 3.1 General terms

##### 3.1.1

##### **roundness**

property of a circle

##### 3.1.2

##### **roundness axis**

axis of a feature associated to an integral feature

NOTE The integral feature can be a cylindrical surface or a surface of revolution.

---

1) To be published. (Revision of ISO/TS 17450-1:2005)

### 3.1.3

#### roundness plane

plane perpendicular to the roundness axis within the full extent of the feature

## 3.2 Terms relating to profiles

### 3.2.1

#### extracted circumferential line

(roundness) digital representation of the intersection of the real surface and the roundness plane

NOTE The extraction conventions for roundness are given in ISO 12181-2. This extracted circumferential line is an extracted integral feature as defined in ISO 14660-1.

### 3.2.2

#### roundness profile

extracted circumferential line intentionally modified by a filter

NOTE This is the profile to which the concepts and parameters of this part of ISO 12181 can be applied.

### 3.2.3

#### local roundness deviation

minimum distance from a point on a roundness profile to the reference circle

See Figures 1 and 2.

NOTE 1 For reference circle, see 3.3.1.

NOTE 2 The deviation is negative if from the reference circle the point lies in the direction of the material.

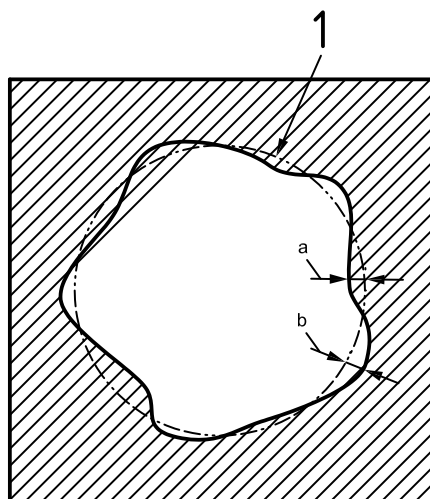

#### Key

- 1 reference circle
- a Positive local deviation.
- b Negative local deviation.

Figure 1 — Local form deviation of an internal roundness feature

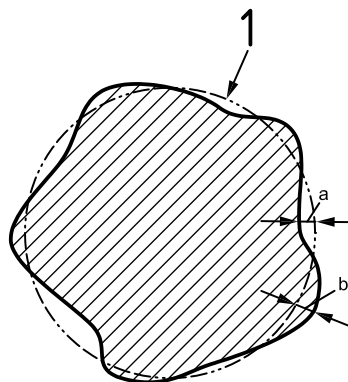

**Key**

- 1 reference circle
- a Negative local deviation.
- b Positive local deviation.

**Figure 2 — Local form deviation of an external roundness feature**

### 3.3 Terms relating to the reference circle

#### 3.3.1

##### **reference circle**

associated circle fitting the roundness profile in accordance with specified conventions, to which the deviations from roundness and the roundness parameters are referred

##### 3.3.1.1

##### **minimum zone reference circles**

two concentric circles enclosing the roundness profile and having the least radial separation

NOTE The abbreviated term MZ is used to refer to minimum zone reference elements.

##### 3.3.1.1.1

##### **outer minimum zone reference circle**

outer circle of the minimum zone reference circles

##### 3.3.1.1.2

##### **inner minimum zone reference circle**

inner circle of the minimum zone reference circles

##### 3.3.1.1.3

##### **mean minimum zone reference circle**

arithmetic mean circle of the minimum zone reference circles

##### 3.3.1.2

##### **least squares reference circle**

circle such that the sum of the squares of the local roundness deviations is a minimum

NOTE The abbreviated term LS is used to refer to least squares reference elements and the letter G (for Gaussian) is used as a prefix for parameters based on least squares reference elements.

##### 3.3.1.3

##### **minimum circumscribed reference circle**

smallest possible circle that can be fitted around the roundness profile

NOTE The abbreviated term MC is used to refer to minimum circumscribed reference elements.

#### 3.3.1.4

##### **maximum inscribed reference circle**

largest possible circle that can be fitted within the roundness profile

NOTE 1 Cases exist where the maximum inscribed reference circle is not unique.

NOTE 2 The abbreviated term MI is used to refer to maximum inscribed reference elements.

#### 3.3.2

##### **associated derived centre**

centre of the reference circle(s)

### 3.4 Terms relating to the circumference

#### 3.4.1

##### **undulations per revolution**

UPR

number of sinusoidal undulations contained in the roundness profile

#### 3.4.2

##### **circumferential wavelength**

circumference of the reference circle divided by the UPR

### 3.5 Terms relating to the filter function

#### 3.5.1 General

NOTE 1 If not otherwise specified, the details of the filter characteristics are as given in ISO 12181-2.

NOTE 2 Only the phase correct mean line filter is defined (see ISO 11562). Consequently, the terms in this subclause relate only to this type of filter. Other filter methods are currently being investigated by ISO. It is intended to incorporate these new filters in a future edition of this part of ISO 12181.

#### 3.5.2

##### **wave filter**

filter operating on a closed profile, transmitting a range of sinusoidal undulations for which the ratio of output to input amplitude is defined, while attenuating (i.e. reducing) the ratio for undulations lying outside the range at either or both ends

#### 3.5.3

##### **undulation cut-off**

cut-off wavelength of the filter applied to the extracted circumferential line

NOTE These are usually defined in terms of undulations per revolution, UPR.

#### 3.5.4

##### **transmission band for roundness profiles**

band of sinusoidal profile undulations which are transmitted by greater than a specified percentage by the filter, defined by the values of the upper and lower undulation cut-off

NOTE The specified percentage is usually 50 %.

## 3.6 Terms relating to parameters

### 3.6.1 General parameters

#### 3.6.1.1

##### **peak-to-valley roundness deviation**

value of the largest positive local roundness deviation added to the absolute value of the largest negative local roundness deviation

NOTE 1 The peak-to-valley roundness deviation is defined for all reference circles.

NOTE 2 The peak-to-valley roundness deviation is the only parameter that is defined for minimum zone, maximum inscribed and minimum circumscribed reference circles.

NOTE 3 The modifier GT is used in specifications to indicate that a form tolerance applies to the peak-to-valley deviation relative to the least squares reference element.

#### 3.6.1.2

##### **peak-to-reference roundness deviation**

value of the largest positive local roundness deviation from the least squares reference circle

NOTE 1 The peak-to-reference roundness deviation is only defined for least squares reference circles.

NOTE 2 The modifier GP is used in specifications to indicate that a form tolerance applies to the peak-to-reference deviation relative to the least squares reference element.

#### 3.6.1.3

##### **reference-to-valley roundness deviation**

absolute value of the largest negative local roundness deviation from the least squares reference circle

NOTE 1 The reference-to-valley roundness deviation is only defined for least squares reference circles.

NOTE 2 The modifier GV is used in specifications to indicate that a form tolerance applies to the reference-to-valley deviation relative to the least squares reference element.

#### 3.6.1.4

##### **root-mean-square roundness deviation**

$\Delta R_{\text{rms}}$

square root of the sum of the squares of the local roundness deviations from the least squares reference circle

NOTE 1 The root-mean-square roundness deviation is only defined for least squares reference circles.

NOTE 2 The modifier GQ is used in specifications to indicate that a form tolerance applies to the root-mean-square deviation relative to the least squares reference element.

NOTE 3 The root-mean-square roundness deviation is given by:

$$\Delta R_{\text{rms}} = \sqrt{\frac{1}{2\pi} \int_0^{2\pi} \Delta R_l^2 d\theta}$$

where

$\Delta R_{\text{rms}}$  is the root-mean-square roundness deviation;

$\Delta R_l$  is the local roundness deviation (see 3.2.3);

$\theta$  is the instantaneous angle in the roundness profile.

### 3.6.2 Terms relating to other parameters of the extracted circumferential line

#### 3.6.2.1

##### **dynamic content**

〈Fourier transform〉 harmonic components (sinewaves) of which the extracted circumferential line is made up

NOTE 1 Dynamic content is expressed as an amplitude and a phase for each UPR number.

NOTE 2 The amplitude for one or more UPR numbers or the sum of the amplitudes of a number of UPR numbers can be specified.

NOTE 3 The parameters defined in 3.6.1 can be specified, including only a specific range of UPR numbers.

NOTE 4 The dynamic content can be used for all reference circles.

## Annex A (informative)

### Mathematical definition of roundness tolerances of nominal integral features

A roundness tolerance zone (see Figure A.1) for a given cross-section of a nominal integral feature consists of a set of points,  $\vec{P}_i$ , subject to the following conditions:

- |  |  |
|--|--|
| $\vec{A}_j = \vec{L} + c_j \hat{N}$                | A coordinate system of arbitrary origin and orientation, points $\vec{A}_j$ are on a line (roundness axis) which is defined by a point, $\vec{L}$ , a direction, $\hat{N}$ , and a scalar distance $c_j$ . |
| $(\vec{A}'_j - \vec{A}_j) \cdot \hat{N} = 0$       | Point $\vec{A}'_j$ is on a roundness plane that contains point $\vec{A}_j$ and whose normal is $\hat{N}$ . Point $\vec{A}'_j$ is the centre of a reference circle.   |
| $(\vec{P}_i - \vec{A}'_j) \cdot \hat{N} = 0$       | Points $\vec{P}_i$ are on a roundness plane that contains point $\vec{A}'_j$ and whose normal is $\hat{N}$ .   |
| $r_{j1} \leq  \vec{P}_i - \vec{A}'_j  \leq r_{j2}$ | Points $\vec{P}_i$ are further restricted to being between two concentric circles (an annular region) of radius, $r_{j1}$ and $r_{j2}$ , which are centred on $\vec{A}'_j$ .                               |
| $t = r_{j2} - r_{j1}, r_{j2} > r_{j1}$             | For each roundness plane, the difference in radius between the concentric circles equals the roundness tolerance, $t$ .  |

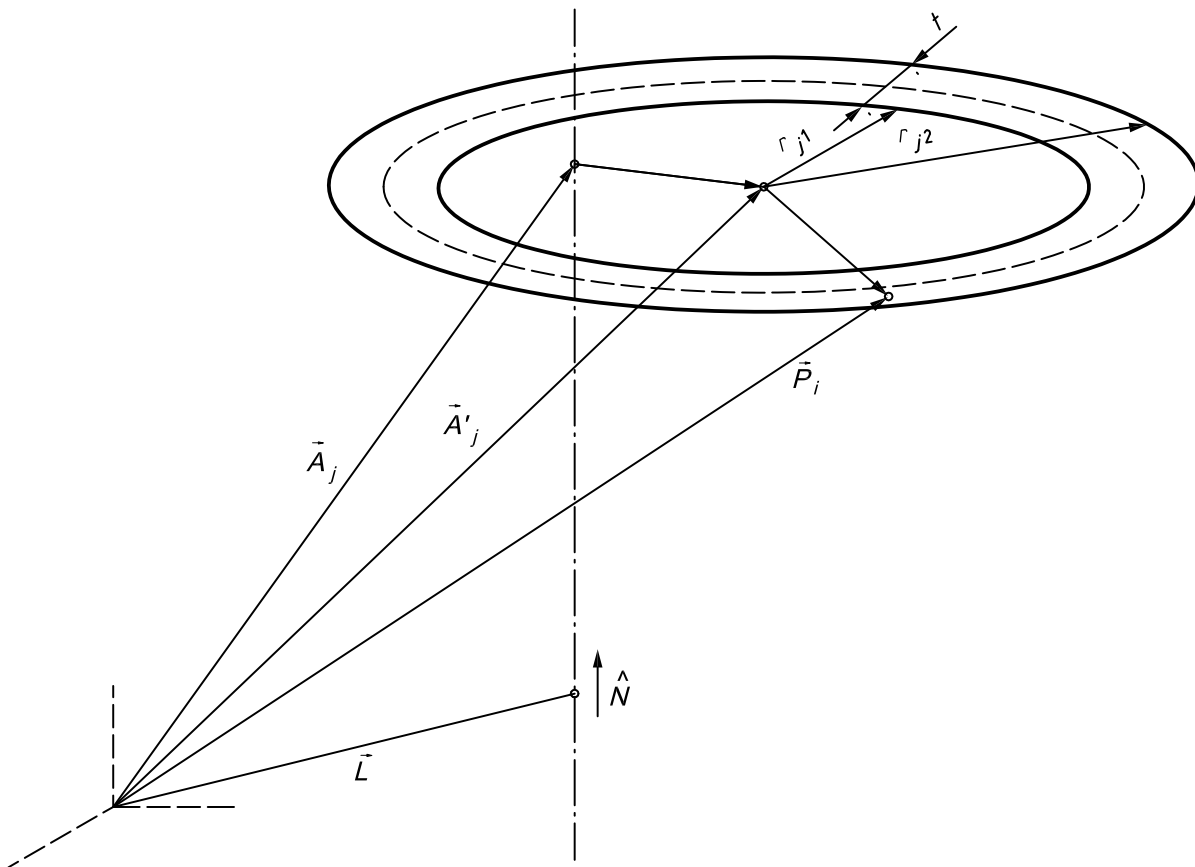

Figure A.1 — Roundness tolerance zone of a nominal integral feature



## Annex B (informative)

### Synoptic tables of terms, abbreviated terms and parameters

The indications of form requirements are based on combinations of symbols and modifiers that uniquely describe the specification operator in a brief form on a drawing. However, there is a need to be able to describe specification and verification operators, e.g. in measurement reports and other technical documentation where it is impractical to rely on drawing symbols. This annex provides textual equivalents for the terms and parameters defined in ISO 12180-1, this part of ISO 12181, ISO 12780-1 and ISO 12781-1, which are recommended for use in those situations.

**Table B.1 — Terms and abbreviated terms**

Abbreviated term	Term	Defined in
LSCI	Least squares reference circle	ISO 12181-1:2011, 3.3.1.2
LSCY	Least squares reference cylinder	ISO 12180-1:2011, 3.3.1.2
LSLI	Least squares reference line	ISO 12780-1:2011, 3.3.1.2
LSPL	Least squares reference plane	ISO 12781-1:2011, 3.3.1.2
LCD	Local cylindricity deviation	ISO 12180-1:2011, 3.2.3
LFD	Local flatness deviation	ISO 12781-1:2011, 3.2.3
LRD	Local roundness deviation	ISO 12181-1:2011, 3.2.3
LSD	Local straightness deviation	ISO 12780-1:2011, 3.2.3
MICI	Maximum inscribed reference circle	ISO 12181-1:2011, 3.3.1.4
MICY	Maximum inscribed reference cylinder	ISO 12180-1:2011, 3.3.1.4
MCCI	Minimum circumscribed reference circle	ISO 12181-1:2011, 3.3.1.3
MCCY	Minimum circumscribed reference cylinder	ISO 12180-1:2011, 3.3.1.3
MZCI	Minimum zone reference circles	ISO 12181-1:2011, 3.3.1.1
MZCY	Minimum zone reference cylinders	ISO 12180-1:2011, 3.3.1.1
MZLI	Minimum zone reference lines	ISO 12780-1:2011, 3.3.1.1
MZPL	Minimum zone reference planes	ISO 12781-1:2011, 3.3.1.1
UPR	Undulations per revolution	ISO 12181-1:2011, 3.4.1

Table B.2 — Parameters and abbreviated terms

Abbreviated term	Parameter	Defined in
CYLrr	Cylinder radii peak-to-valley	ISO 12180-1:2011, 3.5.2.7
CYLtt	Cylinder taper (LSCY)	ISO 12180-1:2011, 3.5.2.5
CYLat	Cylinder taper angle	ISO 12180-1:2011, 3.5.2.8
STRsg	Generatrix straightness deviation	ISO 12180-1:2011, 3.5.2.3
STRlc	Local generatrix straightness deviation	ISO 12180-1:2011, 3.5.2.2
CYLP	Peak-to-reference cylindricity deviation (LSCY) <sup>a</sup>	ISO 12180-1:2011, 3.5.1.2
FLTP	Peak-to-reference flatness deviation (LSPL) <sup>a</sup>	ISO 12781-1:2011, 3.4.2
RONp	Peak-to-reference roundness deviation (LSCI) <sup>a</sup>	ISO 12181-1:2011, 3.6.1.2
STRp	Peak-to-reference straightness deviation (LSLI) <sup>a</sup>	ISO 12780-1:2011, 3.5.2
CYLt	Peak-to-valley cylindricity deviation (MZCY, LSCY, MICY, MCCY) <sup>a</sup>	ISO 12180-1:2011, 3.5.1.1
FLTt	Peak-to-valley flatness deviation (MZPL, LSPL) <sup>a</sup>	ISO 12781-1:2011, 3.4.1
RONt	Peak-to-valley roundness deviation (MZCI, LSCI, MCCI, MICI) <sup>a</sup>	ISO 12181-1:2011, 3.6.1.1
STRt	Peak-to-valley straightness deviation (MZLI, LSLI) <sup>a</sup>	ISO 12780-1:2011, 3.5.1
CYLv	Reference-to-valley cylindricity deviation (LSCY) <sup>a</sup>	ISO 12180-1:2011, 3.5.1.3
FLTv	Reference-to-valley flatness deviation (LSPL) <sup>a</sup>	ISO 12781-1:2011, 3.4.3
RONv	Reference-to-valley roundness deviation (LSCI) <sup>a</sup>	ISO 12181-1:2011, 3.6.1.3
STRv	Reference-to-valley straightness deviation (LSLI) <sup>a</sup>	ISO 12780-1:2011, 3.5.3
CYLq	Root-mean-square cylindricity deviation (LSCY) <sup>a</sup>	ISO 12180-1:2011, 3.5.1.4
FLTq	Root-mean-square flatness deviation (LSPL) <sup>a</sup>	ISO 12781-1:2011, 3.4.4
RONq	Root-mean-square roundness deviation (LSCI) <sup>a</sup>	ISO 12181-1:2011, 3.6.1.4
STRq	Root-mean-square straightness deviation (LSLI) <sup>a</sup>	ISO 12780-1:2011, 3.5.4
STRsa	Straightness deviation of the extracted median line	ISO 12180-1:2011, 3.5.2.1

<sup>a</sup> The abbreviated term given in parentheses after the parameter names indicate the reference elements to which the parameter can be applied.

## Annex C (informative)

### Relationship to the GPS matrix model

#### C.1 General

For full details about the GPS matrix model, see ISO/TR 14638.

The ISO/GPS Masterplan given in ISO/TR 14638 gives an overview of the ISO/GPS system of which this document is a part. The fundamental rules of ISO/GPS given in ISO 8015 apply to this document and the default decision rules given in ISO 14253-1 apply to specifications made in accordance with this document, unless otherwise indicated.

#### C.2 Information about this part of ISO 12181 and its use

This part of ISO 12181 defines terms and concepts necessary for defining the specification operators according to ISO 17450-2 for roundness of integral features.

#### C.3 Position in the GPS matrix model

This part of ISO 12181 is a general GPS standard, which influences chain link 2 of the chain of standards on form of line independent of datum in the general GPS matrix, as graphically illustrated in Figure C.1.

Global GPS standards						
General GPS standards						
Chain link number	1	2	3	4	5	6
Size						
Distance						
Radius						
Angle						
Form of line independent of datum						
Form of line dependent on datum						
Form of surface independent of datum						
Form of surface dependent on datum						
Orientation						
Location						
Circular run-out						
Total run-out						
Datums						
Roughness profile						
Waviness profile						
Primary profile						
Surface defects						
Edges						

**Fundamental  
GPS  
standards**

Figure C.1 — Position in the GPS matrix model

#### **C.4 Related International Standards**

The related International Standards are those of the chains of standards indicated in Figure C.1.

## Bibliography

- [1] ISO 1101, *Geometrical Product Specifications (GPS) — Geometrical tolerancing — Tolerances of form, orientation, location and run-out*
- [2] ISO 8015, *Geometrical product specifications (GPS) — Fundamentals — Concepts, principles and rules*
- [3] ISO 11562, *Geometrical Product Specifications (GPS) — Surface texture: Profile method — Metrological characteristics of phase correct filters*
- [4] ISO 12180-1:2011, *Geometrical product specifications (GPS) — Cylindricity — Part 1: Vocabulary and parameters of cylindrical form*
- [5] ISO 12181-2, *Geometrical product specifications (GPS) — Roundness — Part 2: Specification operators*
- [6] ISO 12780-1:2011, *Geometrical product specifications (GPS) — Straightness — Part 1: Vocabulary and parameters of straightness*
- [7] ISO 12781-1:2011, *Geometrical product specifications (GPS) — Flatness — Part 1: Vocabulary and parameters of flatness*
- [8] ISO 14253-1, *Geometrical Product Specifications (GPS) — Inspection by measurement of workpieces and measuring equipment — Part 1: Decision rules for proving conformance or non-conformance with specifications*
- [9] ISO/TR 14638, *Geometrical product specification (GPS) — Masterplan*
- [10] ISO 17450-2, *Geometrical product specifications (GPS) — General concepts — Part 2: Basic tenets, specifications, operators and uncertainties*





# British Standards Institution (BSI)

BSI is the national body responsible for preparing British Standards and other standards-related publications, information and services.

BSI is incorporated by Royal Charter. British Standards and other standardization products are published by BSI Standards Limited.

## About us

We bring together business, industry, government, consumers, innovators and others to shape their combined experience and expertise into standards-based solutions.

The knowledge embodied in our standards has been carefully assembled in a dependable format and refined through our open consultation process. Organizations of all sizes and across all sectors choose standards to help them achieve their goals.

## Information on standards

We can provide you with the knowledge that your organization needs to succeed. Find out more about British Standards by visiting our website at [bsigroup.com/standards](http://bsigroup.com/standards) or contacting our Customer Services team or Knowledge Centre.

## Buying standards

You can buy and download PDF versions of BSI publications, including British and adopted European and international standards, through our website at [bsigroup.com/shop](http://bsigroup.com/shop), where hard copies can also be purchased.

If you need international and foreign standards from other Standards Development Organizations, hard copies can be ordered from our Customer Services team.

## Subscriptions

Our range of subscription services are designed to make using standards easier for you. For further information on our subscription products go to [bsigroup.com/subscriptions](http://bsigroup.com/subscriptions).

With **British Standards Online (BSOL)** you'll have instant access to over 55,000 British and adopted European and international standards from your desktop. It's available 24/7 and is refreshed daily so you'll always be up to date.

You can keep in touch with standards developments and receive substantial discounts on the purchase price of standards, both in single copy and subscription format, by becoming a **BSI Subscribing Member**.

**PLUS** is an updating service exclusive to BSI Subscribing Members. You will automatically receive the latest hard copy of your standards when they're revised or replaced.

To find out more about becoming a BSI Subscribing Member and the benefits of membership, please visit [bsigroup.com/shop](http://bsigroup.com/shop).

With a **Multi-User Network Licence (MUNL)** you are able to host standards publications on your intranet. Licences can cover as few or as many users as you wish. With updates supplied as soon as they're available, you can be sure your documentation is current. For further information, email [bsmusales@bsigroup.com](mailto:bsmusales@bsigroup.com).

## BSI Group Headquarters

389 Chiswick High Road London W4 4AL UK

## Revisions

Our British Standards and other publications are updated by amendment or revision.

We continually improve the quality of our products and services to benefit your business. If you find an inaccuracy or ambiguity within a British Standard or other BSI publication please inform the Knowledge Centre.

## Copyright

All the data, software and documentation set out in all British Standards and other BSI publications are the property of and copyrighted by BSI, or some person or entity that owns copyright in the information used (such as the international standardization bodies) and has formally licensed such information to BSI for commercial publication and use. Except as permitted under the Copyright, Designs and Patents Act 1988 no extract may be reproduced, stored in a retrieval system or transmitted in any form or by any means – electronic, photocopying, recording or otherwise – without prior written permission from BSI. Details and advice can be obtained from the Copyright & Licensing Department.

## Useful Contacts:

### Customer Services

**Tel:** +44 845 086 9001

**Email (orders):** [orders@bsigroup.com](mailto:orders@bsigroup.com)

**Email (enquiries):** [cservices@bsigroup.com](mailto:cservices@bsigroup.com)

### Subscriptions

**Tel:** +44 845 086 9001

**Email:** [subscriptions@bsigroup.com](mailto:subscriptions@bsigroup.com)

### Knowledge Centre

**Tel:** +44 20 8996 7004

**Email:** [knowledgecentre@bsigroup.com](mailto:knowledgecentre@bsigroup.com)

### Copyright & Licensing

**Tel:** +44 20 8996 7070

**Email:** [copyright@bsigroup.com](mailto:copyright@bsigroup.com)



...making excellence a habit.™