

BS EN ISO 11806-2:2011



BSI Standards Publication

# **Agricultural and forestry machinery — Safety requirements and testing for portable, hand-held, powered brush-cutters and grass- trimmers**

Part 2: Machines for use with back-pack  
power unit (ISO 11806-2:2011)

**bsi.**

...making excellence a habit.™

**National foreword**

This British Standard is the UK implementation of EN ISO 11806-2:2011. It supersedes BS ISO 14865:1998 and BS ISO 14740:1998, which are withdrawn.

The UK participation in its preparation was entrusted to Technical Committee AGE/29, Forestry machinery.

A list of organizations represented on this committee can be obtained on request to its secretary.

This publication does not purport to include all the necessary provisions of a contract. Users are responsible for its correct application.

© The British Standards Institution 2012. Published by BSI Standards Limited 2012

ISBN 978 0 580 66314 7

ICS 65.060.80

**Compliance with a British Standard cannot confer immunity from legal obligations.**

This British Standard was published under the authority of the Standards Policy and Strategy Committee on 30 April 2012.

**Amendments issued since publication**

Date	Text affected
------	---------------

---

ICS 65.060.80

English Version

Agricultural and forestry machinery - Safety requirements and testing for portable, hand-held, powered brush-cutters and grass-trimmers - Part 2: Machines for use with back-pack power unit (ISO 11806-2:2011)

Matériel agricole et forestier - Exigences de sécurité et essais pour débroussailleuses et coupe-herbe portatifs à moteur - Partie 2: Machines pour utilisation avec source motrice portée à dos (ISO 11806-2:2011)

Land- und forstwirtschaftliche Maschinen - Sicherheitstechnische Anforderungen und Prüfung für tragbare handgehaltene motorbetriebene Freischneider und Grastrimmer - Teil 2: Geräte für den Gebrauch mit rükkentragbarer Antriebseinheit (ISO 11806-2:2011)

This European Standard was approved by CEN on 30 November 2011.

CEN members are bound to comply with the CEN/CENELEC Internal Regulations which stipulate the conditions for giving this European Standard the status of a national standard without any alteration. Up-to-date lists and bibliographical references concerning such national standards may be obtained on application to the CEN-CENELEC Management Centre or to any CEN member.

This European Standard exists in three official versions (English, French, German). A version in any other language made by translation under the responsibility of a CEN member into its own language and notified to the CEN-CENELEC Management Centre has the same status as the official versions.

CEN members are the national standards bodies of Austria, Belgium, Bulgaria, Croatia, Cyprus, Czech Republic, Denmark, Estonia, Finland, France, Germany, Greece, Hungary, Iceland, Ireland, Italy, Latvia, Lithuania, Luxembourg, Malta, Netherlands, Norway, Poland, Portugal, Romania, Slovakia, Slovenia, Spain, Sweden, Switzerland and United Kingdom.



EUROPEAN COMMITTEE FOR STANDARDIZATION  
COMITÉ EUROPÉEN DE NORMALISATION  
EUROPÄISCHES KOMITEE FÜR NORMUNG

Management Centre: Avenue Marnix 17, B-1000 Brussels

## Foreword

This document (EN ISO 11806-2:2011) has been prepared by Technical Committee ISO/TC 23 "Tractors and machinery for agriculture and forestry" in collaboration with Technical Committee CEN/TC 144 "Tractors and machinery for agriculture and forestry" the secretariat of which is held by AFNOR.

This European Standard shall be given the status of a national standard, either by publication of an identical text or by endorsement, at the latest by June 2012, and conflicting national standards shall be withdrawn at the latest by June 2012.

Attention is drawn to the possibility that some of the elements of this document may be the subject of patent rights. CEN [and/or CENELEC] shall not be held responsible for identifying any or all such patent rights.

This document has been prepared under a mandate given to CEN by the European Commission and the European Free Trade Association, and supports essential requirements of EU Directive.

For relationship with EU Directive, see informative Annex ZA, which is an integral part of this document.

According to the CEN/CENELEC Internal Regulations, the national standards organizations of the following countries are bound to implement this European Standard: Austria, Belgium, Bulgaria, Croatia, Cyprus, Czech Republic, Denmark, Estonia, Finland, France, Germany, Greece, Hungary, Iceland, Ireland, Italy, Latvia, Lithuania, Luxembourg, Malta, Netherlands, Norway, Poland, Portugal, Romania, Slovakia, Slovenia, Spain, Sweden, Switzerland and the United Kingdom.

### Endorsement notice

The text of ISO 11806-2:2011 has been approved by CEN as a EN ISO 11806-2:2011 without any modification.

## **Annex ZA** (informative)

### **Relationship between this European Standard and the Essential Requirements of EU Directive 2006/42/EC**

This European Standard has been prepared under a mandate given to CEN by the European Commission and the European Free Trade Association to provide one means of conforming to Essential Requirements of the New Approach Directive 2006/42/EC on machinery.

Once this standard is cited in the Official Journal of the European Union under that Directive and has been implemented as a national standard in at least one Member State, compliance with the normative clauses of this standard confers, within the limits of the scope of this standard, a presumption of conformity with the relevant Essential Requirements of that Directive and associated EFTA regulations.

**WARNING — Other requirements and other EU Directives may be applicable to the product(s) falling within the scope of this standard.**

<b>Contents</b>		Page
<b>Foreword</b> .....		<b>iv</b>
<b>Introduction</b> .....		<b>v</b>
<b>1</b>	<b>Scope</b> .....	<b>1</b>
<b>2</b>	<b>Normative references</b> .....	<b>1</b>
<b>3</b>	<b>Terms and definitions</b> .....	<b>2</b>
<b>4</b>	<b>Safety requirements and/or protective measures</b> .....	<b>3</b>
<b>4.1</b>	<b>General</b> .....	<b>3</b>
<b>4.2</b>	<b>Distance to cutting attachment</b> .....	<b>3</b>
<b>4.3</b>	<b>Handgrip on back-pack power unit</b> .....	<b>4</b>
<b>4.4</b>	<b>Harness for back-pack power unit</b> .....	<b>4</b>
<b>4.5</b>	<b>Hydraulic and pneumatic pipes and hoses</b> .....	<b>4</b>
<b>5</b>	<b>Information for use</b> .....	<b>5</b>
<b>Annex A (informative) List of significant hazards</b> .....		<b>6</b>

## Foreword

ISO (the International Organization for Standardization) is a worldwide federation of national standards bodies (ISO member bodies). The work of preparing International Standards is normally carried out through ISO technical committees. Each member body interested in a subject for which a technical committee has been established has the right to be represented on that committee. International organizations, governmental and non-governmental, in liaison with ISO, also take part in the work. ISO collaborates closely with the International Electrotechnical Commission (IEC) on all matters of electrotechnical standardization.

International Standards are drafted in accordance with the rules given in the ISO/IEC Directives, Part 2.

The main task of technical committees is to prepare International Standards. Draft International Standards adopted by the technical committees are circulated to the member bodies for voting. Publication as an International Standard requires approval by at least 75 % of the member bodies casting a vote.

Attention is drawn to the possibility that some of the elements of this document may be the subject of patent rights. ISO shall not be held responsible for identifying any or all such patent rights.

ISO 11806-2 was prepared by Technical Committee ISO/TC 23, *Tractors and machinery for agriculture and forestry*, Subcommittee SC 17, *Manually portable forest machinery*.

This first edition of ISO 11806-2 cancels and replaces ISO 14865:1998 and ISO 14740:1998.

ISO 11806 consists of the following parts, under the general title *Agricultural and forestry machinery — Safety requirements and testing for portable, hand-held, powered brush-cutters and grass-trimmers*:

- *Part 1: Machines fitted with an integral combustion engine*
- *Part 2: Machines for use with back-pack power unit*

## Introduction

This document is a type-C standard as stated in ISO 12100.

The machinery concerned and the extent to which hazards, hazardous situations or hazardous events are covered are indicated in the scope of this document.

When requirements of this type-C standard are different from those which are stated in type-A or type-B standards, the requirements of this type-C standard take precedence over the requirements of the other standards for machines that have been designed and built according to the requirements of this type-C standard.





# Agricultural and forestry machinery — Safety requirements and testing for portable, hand-held, powered brush-cutters and grass-trimmers —

## Part 2: Machines for use with back-pack power unit

### 1 Scope

This part of ISO 11806 gives safety requirements and measures for their verification for the design and construction of portable, hand-held, powered brush-cutters and grass-trimmers with a back-pack-mounted combustion engine power source and mechanical power transmission between the power source and the cutting attachment. Methods for the elimination or reduction of hazards arising from the use of these machines and the type of information on safe working practices to be provided by the manufacturer are specified.

This part of ISO 11806, taken together with the relevant clauses of ISO 11806-1 (see 4.1), deals with all significant hazards, hazardous situations and hazardous events, with the exception of whole-body vibration from the back-pack power unit, relevant to these machines when they are used as intended and under conditions of misuse which are reasonably foreseeable by the manufacturer.

NOTE 1 A standardized test procedure for measuring whole-body vibration from the back-pack power unit is presently not available.

NOTE 2 See Annex A, together with Annex A in ISO 11806-1:2011, for a list of significant hazards.

This part of ISO 11806 is applicable to portable, hand-held, powered brush-cutters and grass-trimmers manufactured after its date of publication.

This part of ISO 11806 is not applicable to machines equipped with metallic cutting attachments consisting of more than one piece, e.g. pivoting chains or flail blades.

### 2 Normative references

The following referenced documents are indispensable for the application of this document. For dated references, only the edition cited applies. For undated references, the latest edition of the referenced document (including any amendments) applies.

ISO 4413:2010, *Hydraulic fluid power — General rules and safety requirements for systems and their components*

ISO 4414:2010, *Pneumatic fluid power — General rules and safety requirements for systems and their components*

ISO 11806-1: 2011, *Agricultural and forestry machinery — Safety requirements and testing for portable, hand-held, powered brush-cutters and grass-trimmers — Part 1: Machines fitted with an integral combustion engine*

ISO 12100:2010, *Safety of machinery — General principles for design — Risk assessment and risk reduction*

ISO 13857:2008, *Safety of machinery — Safety distances to prevent hazard zones being reached by upper and lower limbs*

### 3 Terms and definitions

For the purposes of this document, the terms and definitions given in ISO 11806-1 and the following apply.

NOTE Figure 1 provides an example of a brush-cutter with a back-pack power source falling within the scope of this part of ISO 11806.

#### 3.1

##### appliance

assembly of drive shaft tube, cutting attachment with its guard and handles

#### 3.2

##### machine

complete brush-cutter (or grass-trimmer), including back-pack power unit and appliance

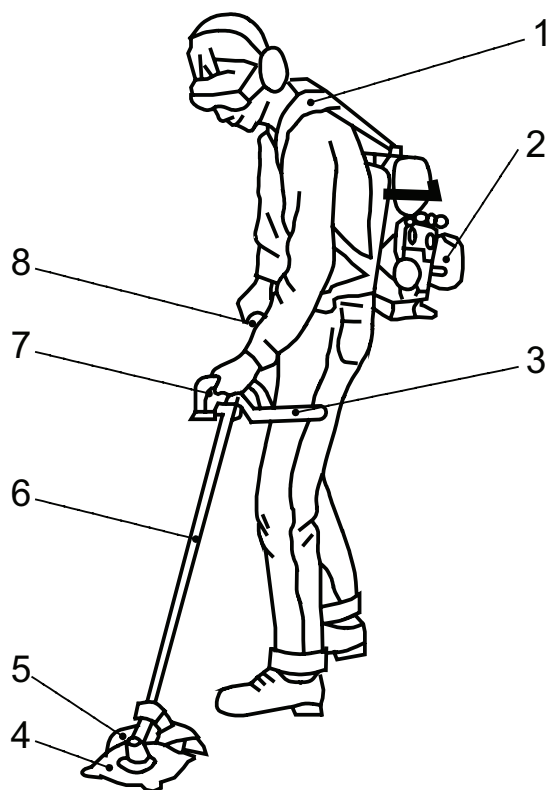

#### Key

- 1 harness
- 2 back-pack power unit
- 3 barrier
- 4 blade
- 5 cutting-attachment guard
- 6 drive-shaft tube
- 7 front handle
- 8 rear handle

Figure 1 — Example of a brush-cutter with back-pack power unit

## 4 Safety requirements and/or protective measures

### 4.1 General

Machines shall comply with the safety requirements and/or protective measures of this clause. In addition, the machine shall be designed according to the principles of ISO 12100 for relevant but not significant hazards which are not dealt with by this part of ISO 11806.

Machines shall comply with ISO 11806-1:2011, Clause 4, except for 4.5.

The safe operation of a brush-cutter and a grass-trimmer also depends on the safe environment associated with the use of personal protective equipment (PPE), such as gloves, slip-resistance footwear, and leg, eye and hearing protective equipment, as well as safe working procedures (see ISO 11806-1:2011, 5.1).

If a grass-trimmer can be converted to a brush-cutter then the converted machine shall comply with requirements for a brush-cutter and vice versa.

Except where otherwise specified in this part of ISO 11806, the safety distances specified in ISO 13857:2008, 4.2.4.1 and 4.2.4.3, shall be met.

### 4.2 Distance to cutting attachment

#### 4.2.1 Requirements

Machines with front and rear handles shall have a minimum straight-line distance of 1 200 mm from the mid-point of the rear handle to the nearest unguarded point of the cutting attachment (point A in Figure 2). Point A is the intersection between the plane perpendicular to the cutting path and the side-edge of the cutting-attachment guard.

This minimum distance shall apply to all recommended cutting attachments.

#### 4.2.2 Verification

The distance shall be verified by measurement.

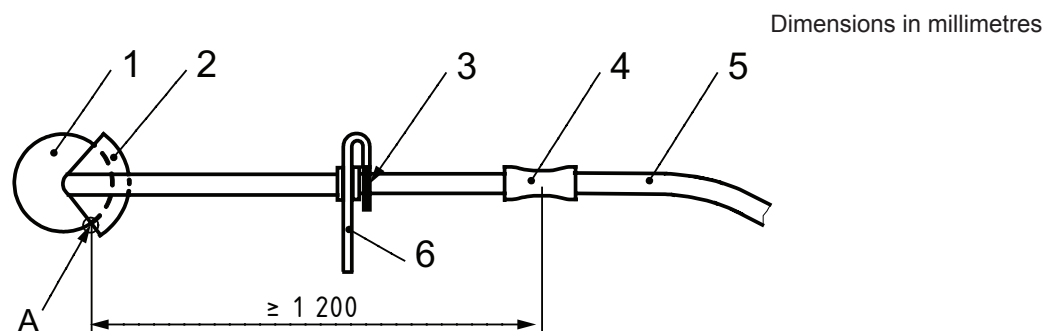

#### Key

- 1 cutting attachment
- 2 guard
- 3 centre at rear of front handle
- 4 handle grip
- 5 flexible power transmission
- 6 barrier

**Figure 2 — Example of an appliance with a saw-blade cutting attachment and front and rear handles**

### **4.3 Handgrip on back-pack power unit**

#### **4.3.1 Requirement**

A handgrip shall be available which may be a part of the frame and which shall allow an operator to grasp the back-pack power unit for handling and transport.

The handgrip shall be designed such that

- it can be fully gripped by an operator when wearing gloves,
- it provides the necessary sureness of grip by its shaping and surface,
- its length is at least 100 mm and where, for a bail or closed hand-grip, this length is straight or curved at a radius greater than 100 mm together with any blend radius, but not more than 10 mm at one or both ends of the gripping surface.

#### **4.3.2 Verification**

The handgrip design shall be verified by inspection, measurement and functional testing.

### **4.4 Harness for back-pack power unit**

#### **4.4.1 Requirements**

A double shoulder harness shall be provided to carry the back-pack power unit. It shall be adjustable to fit the size of the operator.

The harness shall be equipped with a quick-release mechanism positioned either at the connection between the power source and the harness or between the harness and the operator. Either the design of the harness or the use of the quick-release mechanism shall enable the back-pack power unit to be released quickly from the operator in the event of an emergency.

If a quick release mechanism is provided it shall be possible to open it under load to release the back-pack power unit using only one hand.

#### **4.4.2 Verification**

The harness, its functionality and its adjustment shall be verified by inspection. The quick-release mechanism shall be checked by a functional test, carried out by a person wearing the harness with a vertical load of three times the dry weight of the back-pack power unit acting on the suspension point.

### **4.5 Hydraulic and pneumatic pipes and hoses**

#### **4.5.1 Requirements**

Hydraulic systems shall comply with the safety requirements of ISO 4413. Pneumatic systems shall comply with the safety requirements of ISO 4414.

Hydraulic and pneumatic pipes and hoses subject to internal pressures in excess of 500 kPa shall be shielded so that in the event of rupture during operation of the machine, the fluid cannot be discharged directly onto the operator.

#### **4.5.2 Verification**

The shielding of pipes and hoses shall be verified by inspection.

## **5 Information for use**

The instruction handbook to be provided with the machine shall comply with ISO 11806-1:2011, 5.1.

The machine shall be marked in accordance with ISO 11806-1:2011, 5.2, and carry warnings in accordance with ISO 11806-1:2011, 5.3.

## Annex A (informative)

### List of significant hazards

This annex specifies the additional significant hazards, hazardous situations and significant hazardous events that have been identified as being significant for the back-pack power unit for brush-cutters and grass-trimmers and which require specific action by the designer or manufacturer to eliminate or reduce the risk.

**Table A.1 — List of significant hazards associated with back-pack power unit for brush-cutters and grass-trimmers**

Ref. No.	Hazard		Subclause of this part of ISO 11806
	Origin (source)	Potential consequences	
1	<b>Mechanical hazards</b>		
	Hydraulic and pneumatic system	Injury from high-pressure fluid injection	4.4
2	<b>Combination of hazards</b>		
	Poor postures or excessive effort in combination with inadequate design or location of manual controls, including inadequate consideration of human hand-arm anatomy, related to handle design and machine balance.	Discomfort, fatigue, injuries to locomotor apparatus, loss of control	4.2, 4.3







# British Standards Institution (BSI)

BSI is the national body responsible for preparing British Standards and other standards-related publications, information and services.

BSI is incorporated by Royal Charter. British Standards and other standardization products are published by BSI Standards Limited.

## About us

We bring together business, industry, government, consumers, innovators and others to shape their combined experience and expertise into standards-based solutions.

The knowledge embodied in our standards has been carefully assembled in a dependable format and refined through our open consultation process. Organizations of all sizes and across all sectors choose standards to help them achieve their goals.

## Information on standards

We can provide you with the knowledge that your organization needs to succeed. Find out more about British Standards by visiting our website at [bsigroup.com/standards](http://bsigroup.com/standards) or contacting our Customer Services team or Knowledge Centre.

## Buying standards

You can buy and download PDF versions of BSI publications, including British and adopted European and international standards, through our website at [bsigroup.com/shop](http://bsigroup.com/shop), where hard copies can also be purchased.

If you need international and foreign standards from other Standards Development Organizations, hard copies can be ordered from our Customer Services team.

## Subscriptions

Our range of subscription services are designed to make using standards easier for you. For further information on our subscription products go to [bsigroup.com/subscriptions](http://bsigroup.com/subscriptions).

With **British Standards Online (BSOL)** you'll have instant access to over 55,000 British and adopted European and international standards from your desktop. It's available 24/7 and is refreshed daily so you'll always be up to date.

You can keep in touch with standards developments and receive substantial discounts on the purchase price of standards, both in single copy and subscription format, by becoming a **BSI Subscribing Member**.

**PLUS** is an updating service exclusive to BSI Subscribing Members. You will automatically receive the latest hard copy of your standards when they're revised or replaced.

To find out more about becoming a BSI Subscribing Member and the benefits of membership, please visit [bsigroup.com/shop](http://bsigroup.com/shop).

With a **Multi-User Network Licence (MUNL)** you are able to host standards publications on your intranet. Licences can cover as few or as many users as you wish. With updates supplied as soon as they're available, you can be sure your documentation is current. For further information, email [bsmusales@bsigroup.com](mailto:bsmusales@bsigroup.com).

## BSI Group Headquarters

389 Chiswick High Road London W4 4AL UK

## Revisions

Our British Standards and other publications are updated by amendment or revision.

We continually improve the quality of our products and services to benefit your business. If you find an inaccuracy or ambiguity within a British Standard or other BSI publication please inform the Knowledge Centre.

## Copyright

All the data, software and documentation set out in all British Standards and other BSI publications are the property of and copyrighted by BSI, or some person or entity that owns copyright in the information used (such as the international standardization bodies) and has formally licensed such information to BSI for commercial publication and use. Except as permitted under the Copyright, Designs and Patents Act 1988 no extract may be reproduced, stored in a retrieval system or transmitted in any form or by any means – electronic, photocopying, recording or otherwise – without prior written permission from BSI. Details and advice can be obtained from the Copyright & Licensing Department.

## Useful Contacts:

### Customer Services

**Tel:** +44 845 086 9001

**Email (orders):** [orders@bsigroup.com](mailto:orders@bsigroup.com)

**Email (enquiries):** [cservices@bsigroup.com](mailto:cservices@bsigroup.com)

### Subscriptions

**Tel:** +44 845 086 9001

**Email:** [subscriptions@bsigroup.com](mailto:subscriptions@bsigroup.com)

### Knowledge Centre

**Tel:** +44 20 8996 7004

**Email:** [knowledgecentre@bsigroup.com](mailto:knowledgecentre@bsigroup.com)

### Copyright & Licensing

**Tel:** +44 20 8996 7070

**Email:** [copyright@bsigroup.com](mailto:copyright@bsigroup.com)



...making excellence a habit.™