

Leather — Test for adhesion of finish (ISO 11644:2009)

ICS 59.140.10

National foreword

This British Standard is the UK implementation of EN ISO 11644:2009. It supersedes BS EN ISO 11644:2003 which is withdrawn.

The UK participation in its preparation was entrusted to Technical Committee TCI/69, Footwear, leather and coated fabrics.

A list of organizations represented on this committee can be obtained on request to its secretary.

This publication does not purport to include all the necessary provisions of a contract. Users are responsible for its correct application.

Compliance with a British Standard cannot confer immunity from legal obligations.

This British Standard was published under the authority of the Standards Policy and Strategy Committee on 30 June 2009.

© BSI 2009

ISBN 978 0 580 58151 9

Amendments/corrigenda issued since publication

Date	Comments

English Version

Leather - Test for adhesion of finish (ISO 11644:2009)

Cuir - Essai d'adhérence du finissage (ISO 11644:2009)

Leder - Prüfung der Haftfestigkeit von Zurichtungen (ISO 11644:2008)

This European Standard was approved by CEN on 6 May 2009.

CEN members are bound to comply with the CEN/CENELEC Internal Regulations which stipulate the conditions for giving this European Standard the status of a national standard without any alteration. Up-to-date lists and bibliographical references concerning such national standards may be obtained on application to the CEN Management Centre or to any CEN member.

This European Standard exists in three official versions (English, French, German). A version in any other language made by translation under the responsibility of a CEN member into its own language and notified to the CEN Management Centre has the same status as the official versions.

CEN members are the national standards bodies of Austria, Belgium, Bulgaria, Cyprus, Czech Republic, Denmark, Estonia, Finland, France, Germany, Greece, Hungary, Iceland, Ireland, Italy, Latvia, Lithuania, Luxembourg, Malta, Netherlands, Norway, Poland, Portugal, Romania, Slovakia, Slovenia, Spain, Sweden, Switzerland and United Kingdom.



EUROPEAN COMMITTEE FOR STANDARDIZATION
COMITÉ EUROPÉEN DE NORMALISATION
EUROPÄISCHES KOMITEE FÜR NORMUNG

Management Centre: Avenue Marnix 17, B-1000 Brussels

Foreword

This document (EN ISO 11644:2009) has been prepared by Technical Committee CEN/TC 289 "Leather", the secretariat of which is held by UNI, in collaboration with Technical Committee ISO/TC IULTCS "International Union of Leather Technologists and Chemists Societies".

This European Standard shall be given the status of a national standard, either by publication of an identical text or by endorsement, at the latest by November 2009, and conflicting national standards shall be withdrawn at the latest by November 2009.

Attention is drawn to the possibility that some of the elements of this document may be the subject of patent rights. CEN [and/or CENELEC] shall not be held responsible for identifying any or all such patent rights.

This document supersedes EN ISO 11644:2003.

According to the CEN/CENELEC Internal Regulations, the national standards organizations of the following countries are bound to implement this European Standard: Austria, Belgium, Bulgaria, Cyprus, Czech Republic, Denmark, Estonia, Finland, France, Germany, Greece, Hungary, Iceland, Ireland, Italy, Latvia, Lithuania, Luxembourg, Malta, Netherlands, Norway, Poland, Portugal, Romania, Slovakia, Slovenia, Spain, Sweden, Switzerland and the United Kingdom.

Contents

Page

Foreword.....	iv
Introduction	v
1 Scope	1
2 Normative references	1
3 Terms and definitions.....	1
4 Principle.....	1
5 Apparatus and materials.....	2
6 Preparation of test specimens	4
7 Conditioning of the test specimens.....	5
8 Procedure	6
9 Test report	9
Annex A (informative) Commercial sources for apparatus and materials	10
Annex B (informative) Precision data from interlaboratory collaborative trial	11

Foreword

ISO (the International Organization for Standardization) is a worldwide federation of national standards bodies (ISO member bodies). The work of preparing International Standards is normally carried out through ISO technical committees. Each member body interested in a subject for which a technical committee has been established has the right to be represented on that committee. International organizations, governmental and non-governmental, in liaison with ISO, also take part in the work. ISO collaborates closely with the International Electrotechnical Commission (IEC) on all matters of electrotechnical standardization.

International Standards are drafted in accordance with the rules given in the ISO/IEC Directives, Part 2.

The main task of technical committees is to prepare International Standards. Draft International Standards adopted by the technical committees are circulated to the member bodies for voting. Publication as an International Standard requires approval by at least 75 % of the member bodies casting a vote.

Attention is drawn to the possibility that some of the elements of this document may be the subject of patent rights. ISO shall not be held responsible for identifying any or all such patent rights.

ISO 11644/IUF 470 was prepared by the European Committee for Standardization (CEN) Technical Committee CEN/TC 289, *Leather*, in collaboration with the Fastness Tests Commission of the International Union of Leather Technologists and Chemists Societies (IUF Commission, IULTCS), in accordance with the Agreement on technical cooperation between ISO and CEN (Vienna Agreement). It is based on IUF 470 published in *J. Soc. Leather Tech. Chem.*, **74**, pp. 155-160, 1990, and was declared an official method of the IULTCS in September 1991.

IULTCS, originally formed in 1897, is a world-wide organization of professional leather societies to further the advancement of leather science and technology. IULTCS has three Commissions, which are responsible for establishing international methods for the sampling and testing of leather. ISO recognizes IULTCS as an international standardizing body for the preparation of test methods for leather.

This second edition cancels and replaces the first edition (ISO 11644:1993), which has been technically revised. This new version is a general update of the procedures, including an alternative adhesive and electronic evaluation of the force.

Introduction

Prior to the first edition of this International Standard in 1993, a similar test method to that specified here, using an epoxy adhesive and metal adherent-plates had been in use in the leather trade for many years, but was never declared an official method by IULTCS or ISO. The adhesive frequently penetrates thin finish films, thus increasing the adhesion value unrealistically, and it is usually not possible to measure wet adhesion, as there is insufficient adhesion to the metal when water is present. Finishes with insufficient adhesion to the adhesive also occur quite frequently. In spite of these drawbacks, this old method was used regularly and was referred to in many specifications. The method specified in this International Standard eliminates most of these drawbacks.

The adhesives used in this method harden quickly and there is no time for them to penetrate even quite thin finishes unless the finish has open cracks in it. While adhesion to most finishes is sufficient, a few cases still exist in which the adhesion is insufficient and either a different adhesive has to be used or the surface lightly roughened. As the adhesive does not penetrate, it is quite possible to test different layers of a multi-layer finish separately. Such a finish can be tested several times until all the layers have been removed from the leather. It would be advisable for specifications to make allowance for this fact.

A strip of hard PVC is used as the adherent-plate; this gives good adhesion under wet conditions. Wet adhesion can therefore be measured easily. Experience has shown that this “real” wet-adhesion value is often lower, a fact that must also be considered when drawing up specifications based on this method.

Leather — Test for adhesion of finish

1 Scope

This International Standard specifies a method for measuring the adhesion of the finish to leather or the adhesion between two adjacent layers of the finish.

The method is valid for all finished leathers with a smooth surface that can be bonded to an adherent-plate without the adhesive penetrating into the finish. Preliminary experiments might be necessary to determine whether these conditions are met.

This test method is valid for finished leathers with a finish-coat thickness of at least 15 µm.

2 Normative references

The following referenced documents are indispensable for the application of this document. For dated references, only the edition cited applies. For undated references, the latest edition of the referenced document (including any amendments) applies.

ISO 105-A02, *Textiles — Tests for colour fastness — Part A02: Grey scale for assessing change in colour*

ISO 2418, *Leather — Chemical, physical and mechanical and fastness tests — Sampling location*

ISO 2419, *Leather — Physical and mechanical tests — Sample preparation and conditioning*

ISO 3696, *Water for analytical laboratory use — Specification and test methods*

3 Terms and definitions

For the purposes of this document, the following terms and definitions apply.

3.1

adhesion

force required to pull the leather away from its surface finish layer, the force being applied steadily, at an angle of about 90°, to a rigid adherent-plate to which the finished side of the leather has been bonded

4 Principle

The finished side of part of a strip of leather is bonded to an adherent-plate by means of an adhesive film. Force is applied to the free end of the strip to peel the leather from the finish over a given distance, the finish layer remaining on the adherent-plate together with the film of adhesive. The force required is measured and reported as the adhesion value of the finish.

The test is usually carried out on specimens conditioned in a standard atmosphere before testing. If required, the test may additionally be carried out on wetted specimens or on specimens that have previously been subjected to other treatments.

5 Apparatus and materials

5.1 Tensile-testing machine, incorporating the following features:

- a) a force range appropriate to the specimen under test;
- b) a uniform speed of separation of the jaws of $100 \text{ mm/min} \pm 5 \text{ mm/min}$;
- c) suitable means for fixing the adherent-plate holder (5.3) and either the hook link (5.4) or clamp (5.5);
- d) provision for recording a force-distance diagram during the test.

5.2 Adherent-plate, comprising a piece of hard poly(vinyl chloride) (PVC), or another suitable material, measuring approximately $70 \text{ mm} \times 20 \text{ mm} \times 3 \text{ mm}$, to which the leather specimen is bonded. PVC with a high infrared (IR) absorption is preferred.

5.3 Adherent-plate holder (see Figure 1), made of any suitable material, for holding the adherent-plate, to which the leather specimen has been bonded, in the lower clamp of the tensile-testing machine. Optionally, the plates can be held firmly by screws through the sides of the plate holder, see Figure 5.

Dimensions in millimetres

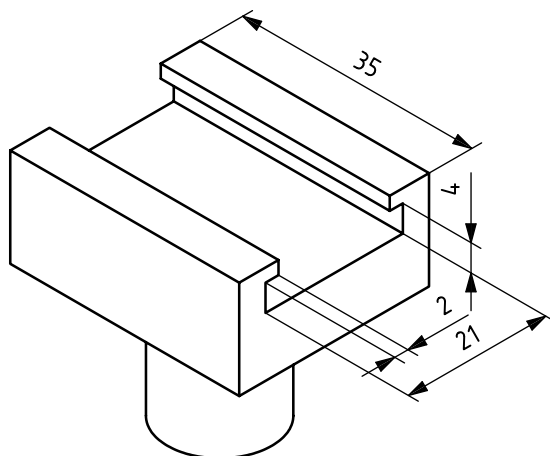

Figure 1 — Adherent-plate holder ($\pm 2 \text{ mm}$ for 35 mm, otherwise $\pm 1 \text{ mm}$)

Either:

5.4 Hook link, made of steel wire 1 mm to 2 mm in diameter, at least 200 mm long, for attaching the free end of the leather specimen to the upper clamp of the tensile-testing machine (see Figures 2 and 4). The length of the hook link ensures that the angle of peel always remains close to 90° .

Or:

5.5 Flat-jawed laboratory screw clamp (see Figure 3), suitable for clamping the leather sample with a suitable attachment for connecting the laboratory clamp to the upper jaw of the tensile-testing machine, see Figure 5. The length of this attachment should be approximately 250 mm long to ensure that the angle of peel remains close to 90° . Alternatively, a flat-jawed device fitted directly to a tensile-testing machine, such that a peel angle of 90° can be maintained throughout the test, may be used.

5.6 Punch, suitable for making a hole 2 mm to 3 mm in diameter in the leather specimen, if using the hook link (5.4).

Dimensions in millimetres

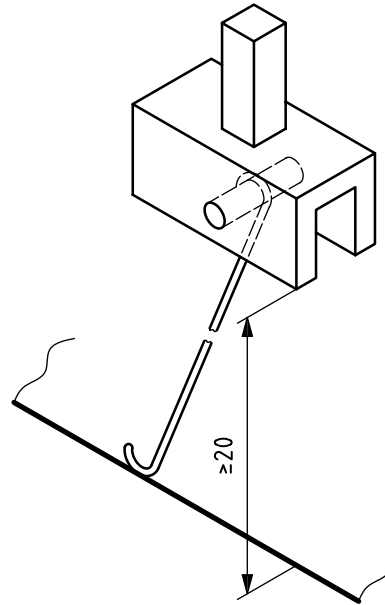

Figure 2 — Hook link

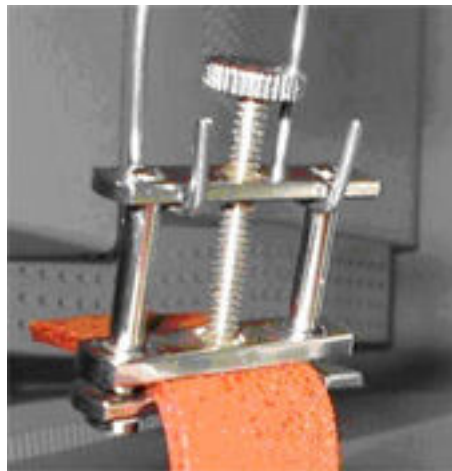

Figure 3 — Flat-jawed clamp

5.7 Adhesive, suitable for bonding the leather specimen to the adherent-plate. Types of adhesives found to give satisfactory, reproducible results are

- a single-component cyanoacrylate adhesive, of the instant adhesive type that hardens and bonds within a very short time to avoid penetration of the adhesive through the finish layer, and
- a two-component polyurethane adhesive, comprising a resin and a hardener.

For the two-component adhesive, usually 20 g of solid resin is dissolved in 80 g of ethyl acetate and 5 g of hardener is added, unless otherwise instructed by the supplier of the adhesive. The adhesive shall be used within 8 h of adding the hardener, unless otherwise instructed by the supplier.

NOTE Examples of suitable adhesives available commercially are given in Annex A.

5.8 Infrared lamp or oven, capable of heating the adherent-plate (5.2) such that the adhesive is activated. This lamp (oven) is only required if the two-component adhesive is used.

5.9 Weight-piece, of mass approximately 4,5 kg, with a flat base.

5.10 Cleaning solvent, hexane or a mixture of alkanes boiling within the range of 40 °C to 80 °C (e.g. petroleum ether), for cleaning the surface of the adherent-plate and the finished side of the leather specimen before bonding.

5.11 Cutter, capable of cutting a specimen of 100 mm ± 2 mm × 10 mm ± 1 mm from the leather with one stroke.

5.12 Apparatus for wetting the test specimen, comprising the elements specified in 5.12.1 to 5.12.3. This apparatus is only required when wetted leathers are to be tested.

5.12.1 Vacuum-desiccator vessel, or another glass container suitable for evacuation.

5.12.2 Vacuum pump, capable of evacuating the desiccator vessel (5.12.1) to approximately 5 kPa (50 mbar) within approximately 4 min.

5.12.3 Beaker, filled with distilled water at approximately 20 °C, in which the test specimens (leather bonded to adherent-plate) can be completely submerged.

5.13 Grey scale for assessing change in colour, in accordance with ISO 105-A02. (This is only required when the change in colour of the leather surface is to be assessed after undergoing the test and re-polishing).

5.14 Demineralized water, grade 3 in accordance with ISO 3696.

6 Preparation of test specimens

6.1 From the piece of leather to be tested, cut out, with one stroke of the cutter (5.11), strips measuring 100 mm ± 2 mm × 10 mm ± 1 mm.

Take at least four leather specimens, two with their long axis parallel to the backbone and two with their long axis at right angles to the backbone, for each leather specimen location and for each type of test specimen conditioning.

The adhesion of a finish to the leather may vary considerably, even within a single piece (skin, side, shoulder, etc.). If it is necessary to evaluate these variations, it is recommended that the leather specimens be taken not only from the positions specified in ISO 2418, but also from the shoulder and belly.

NOTE For some types of shoe upper leather it might be desirable to use a wider specimen size and correspondingly wider adherent-plates. If another specimen size is used, this must be included in the test report.

6.2 If using the hook link system of removing the finish, then using the punch (5.6), make holes approximately 2 mm to 3 mm in diameter at each end of the centreline of each strip, about 5 mm from the end.

Either:

6.3 For the **two-component adhesive**, attach the leather specimen to the adherent-plate.

6.3.1 Clean the surface of the adherent-plate (5.2) to which the leather specimen is to be bonded and the finished side of the leather with a clean piece of cloth wetted with cleaning solvent (5.10).

CAUTION — Use adequate ventilation, avoid contact of the solvent with the skin and wear eye protection.

6.3.2 Carefully apply the adhesive as a uniform thin layer to the cleaned surface of the adherent-plate and then store at room temperature for at least 30 min. The adherent-plate with the adhesive shall be used within 8 h of applying the adhesive. For leathers with a coarse grain, several layers of adhesive shall be applied, in order to ensure that the grooves in the leather will be filled.

6.3.3 Heat the adhesive film on the adherent-plate, either with the IR lamp or by placing it in the oven for 10 min at 85 °C. Immediately afterwards, place the leather specimen with the finish down on the adhesive film, with the leather extending about 15 mm beyond each end of the plate, and then place the weight-piece (5.9) on the leather for at least 2 h.

Or:

6.4 For the **single-component adhesive**, attach the leather specimen to the adherent-plate.

6.4.1 Clean the surface of the adherent-plate (5.2) to which the leather specimen is to be bonded and the finished side of the leather with a clean piece of cloth wetted with solvent (5.10).

CAUTION — Use adequate ventilation, avoid contact of the solvent with the skin and wear eye protection.

6.4.2 Apply the adhesive (5.7) as a thin layer to the cleaned surface of the adherent-plate. Take care to apply the adhesive uniformly according to the supplier's instructions. Approximately 1 min afterwards, carefully place the leather specimen with the finish down onto the adhesive, with the leather extending about 15 mm beyond each end of the plate, and then place the weight-piece (5.9) on the leather for at least 15 min.

CAUTION — Avoid contact of the liquid cyanoacrylate adhesive with the skin.

NOTE Especially when testing the adhesion of the finish of leathers with heavy prints, even adhesion can be ensured by rolling the upper surface of the leather with a hand roller, while applying moderate pressure, before the weight-piece is placed on the test specimen.

6.5 It can be difficult to get satisfactory adhesion with some leathers, especially with the polyurethane-based adhesive. To avoid such problems, a commonly used procedure to achieve good adhesion is a very slight roughening of the finish surface with a fine sand-paper (P600), e.g. twice back and forward, followed by cleaning with solvent. This roughening should not penetrate the finish layer.

6.6 To avoid incorrect (high) results caused by adhesion to the side of the leather specimen, any lateral excess of adhesive should be avoided. If there is evidence that the adhesive has run down the sides of the test piece and into the cut edge, the test piece should be discarded and a new one prepared.

7 Conditioning of the test specimens

7.1 All test specimens, except those to be tested wet, shall be conditioned for at least 16 h in the standard atmosphere specified in ISO 2419 before testing.

7.2 Tests on wetted leather are often instructive. It shall be noted, however, that difficulties can arise as a result of uneven wetting or swelling of the leather, or the effect of the water on the adhesive.

If the leather is to be tested wet, allow the test specimen to stand for at least 16 h for the two-component polyurethane adhesive and at least 1 h for the single-component cyanoacrylate adhesive after bonding the leather to the adherent-plate, and then condition as follows:

Immerse the test specimen completely in demineralized water (5.14) in the beaker (5.12.3). Place the beaker in the vacuum desiccator (5.12.1) and evacuate the desiccator to about 5 kPa within approximately 4 min. Hold the vacuum for approximately 2 min and then release it. Repeat the evacuation/pressure-release process two more times. Leave the test specimen immersed in the water at 20 °C ± 2 °C for a length of time such that the adhesion test is carried out at least 30 min, but not more than 120 min, after the time the test

specimen was first immersed in the water. When the test specimen is taken out for testing, remove excess water with absorbent paper for instance.

8 Procedure

8.1 Fix the holder (5.3) in the lower clamp of the tensile-testing machine (5.1).

8.2 Slide the conditioned test specimen (adherent-plate with leather specimen bonded to it) into the holder until one end of the plate is flush with one end of the holder.

8.3 **Either:** Attach one end of the hook link (5.4) in the upper clamp of the tensile-testing machine and attach the other end to the leather specimen by hooking it into the hole at the end of it (see Figure 4).

Or: Attach one end of an attachment (see 5.5) or two hook links (5.4) in the upper clamp of the tensile-testing machine and attach the other ends to a flat-jawed laboratory screw clamp (5.5), which is clamped firmly to the end of the leather specimen (see Figure 5).

For some leather types, it may be desirable to use the flat-jawed clamp system to stop the specimen from curling up as the finish is peeled off. With the flat-jawed clamp, the tension is even over the whole width of the sample. The finish should peel off as evenly as possible over the whole width.

NOTE After fixing the attachments to the upper clamp of the tensile-testing machine, it must be zeroed (or tared) to take account of the mass.

Dimensions in millimetres

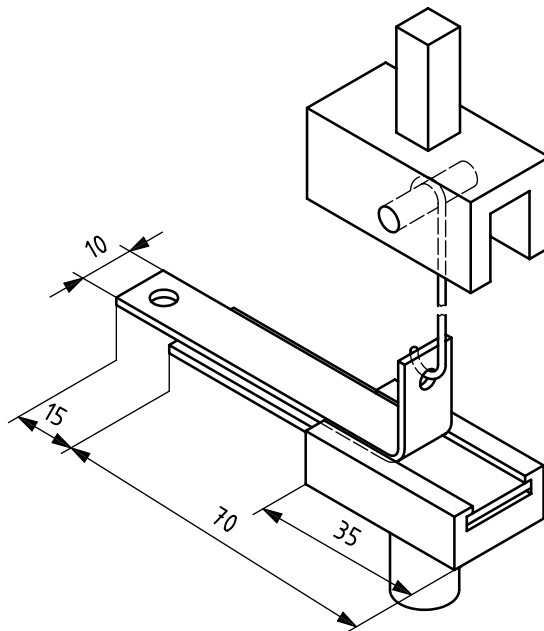

Figure 4 — Arrangement of test specimen and clamps for test with hook link system
(± 1 mm for 10 mm, otherwise ± 2 mm)

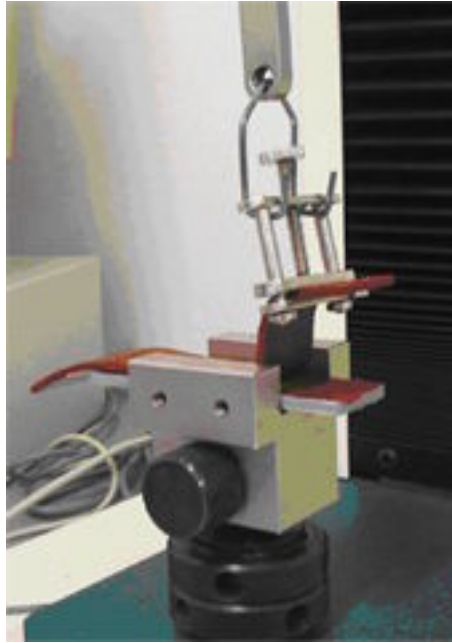

Figure 5 — Arrangement of test specimen and clamps for test with flat-jawed clamp system

8.4 Set the tensile-testing machine to a uniform speed of separation of the jaws of $100 \text{ mm/min} \pm 5 \text{ mm/min}$, and record the force-distance diagram for the separation of the finish from the leather over a distance of 30 mm to 35 mm. Stop and reverse the tensile-testing machine so that the leather specimen can be released.

The force shall be applied such that the leather specimen peels off at an angle of about 90° to the rigid adherent-plate.

Observe how the finish separates from the leather. Report the appearance of the leather and film after the test, especially the way in which the finish has separated, e.g. as a smooth film or as individual layers. Also note details of any failures in the test specimen that may not be revealed by the force-distance diagram, e.g. separation of the adhesive bond from the adherent-plate or tearing of the leather. If adhesion failure occurs, the adhesion value for that particular determination shall not be used to calculate a mean adhesion value. If adhesion failure occurs with all the specimens, reject the results and repeat the test using a different method of adhesion.

If the finish remains mostly on the leather, change the method of bonding and repeat with a new test specimen.

If the leather is coated with a thick finish (e.g. patent leather) or laminated with a film, make a cut through the finish only, across the width of the leather specimen, just beyond that end of the adherent-plate where separation will begin. This ensures that the tensile properties of the finish will not influence the results.

8.5 Reverse the direction of the test specimen in the holder. Repeat the peeling procedure in the opposite direction in accordance with 8.2, 8.3 and 8.4.

The adhesion of the finish to the leather may vary with the direction of the hair follicles, and with the buffing direction in corrected-grain leathers. It is therefore essential to measure the adhesion of the finish in both directions on each leather specimen.

8.6 For each force-distance diagram, shown schematically in Figure 6, determine the mean force during the peel propagation of the finish over about 30 mm of the leather specimen, i.e. the adhesion value. Record this adhesion value, expressed in newtons per 10 mm (i.e. the width of sample), rounded to the nearest 0,1 N/10 mm.

If the leather specimen width is other than 10 mm, then this shall be noted in the test report.

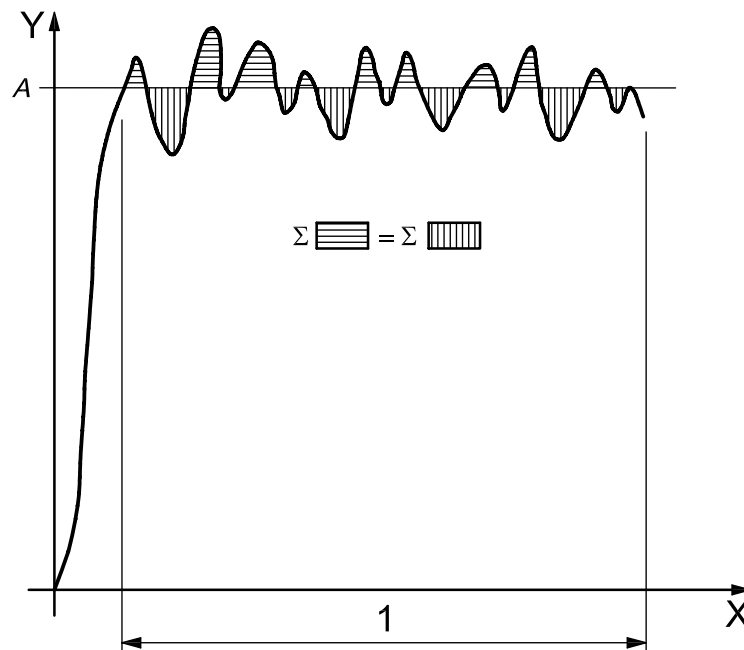

Key

- 1 distance approximately 30 mm
- A adhesion value
- X distance
- Y force

Figure 6 — Evaluation of force-distance diagram

The registration of the force is started after the first force maximum (initial surge peak). All peaks are registered, but the first and last 10 % of the displacement are not to be used for the evaluation. The force of adhesion is calculated from the mean value of the force peaks and valleys.

NOTE If no force peaks are present, the total displaced distance (excluding the first and last 10 %) is divided into 9 sections of equal distance. The adhesion force is calculated from the mean value of the force values at the start of each section.

8.7 For each test-specimen condition (dry, wet, etc.), calculate and record the mean of all adhesion values obtained.

8.8 If required, assess the differences in colour between the surface from which the finish has been removed, the same surface after it has been polished, and the original finished leather, using the grey scale (5.13) in accordance with ISO 105-A02.

NOTE If the leather has not been dyed, or has been dyed in a colour which does not match the finish, the colour of the leather surface from which the finish has been removed will differ to a greater or lesser extent from that of the original finished leather.

9 Test report

The test report shall include the following information:

- a) a reference to this International Standard;
- b) a description of the type of leather tested;
- c) the adhesive used;
- d) the number of leather specimens tested, the positions from which they were taken and details of the conditioning procedure used;
- e) the mean adhesion values determined, in newtons per 10 mm; if requested, the adhesion values from all the leather specimens tested under the same conditions and for each direction;
- f) any differences in the way in which the finish separated from the leather (see 8.4);
- g) if required, the numerical rating for the differences in colour between the leather with the finish intact and the leather after removal of the finish and polishing;
- h) details of any deviations from the procedure.

Annex A (informative)

Commercial sources for apparatus and materials

Examples of suitable products available commercially are given below. This information is given for the convenience of users of this International Standard and does not constitute an endorsement by ISO of these products.

A.1 Pieces of hard PVC, measuring 70 mm × 20 mm × 3 mm, to be used as adherent-plates, may be obtained in lots of 100 or 1 000 from EMPA Testmaterials, Mövenstrasse 12, CH-9015 St. Gallen, Switzerland.

A.2 Single-component cyanoacrylate adhesives of the instant adhesive type. For example, the commercially available Loctite[®] 401 Universal adhesive.

A.3 Two-component polyurethane adhesives whose components react at approximately 80 °C are suitable as the adhesive. For example, small quantities of Desmocoll[®] 400 (resin) and Desmodur[®] L 75 (hardener) can be obtained from Jaekle Chemie GmbH & Co. KG, Matthiasstrasse 10 – 12, D-90431 Nuernberg, Germany.

Annex B (informative)

Precision data from interlaboratory collaborative trial

B.1 Interlaboratory collaborative trial

Carried out by the Leather Testing Commission of VGCT, Germany, in 2003: 6 laboratories, standard atmosphere method with single- and two-component adhesives. See Table B.1.

Table B.1 — Precision data of interlaboratory round trial

Sample	Adhesion value of finish N/10 mm	Standard deviation
Leather A	8,8	1,3
Leather B	4,5	0,6

B.2 Comparison of sample preparation procedures

Carried out by the Leather Tanning School Reutlingen (LGR), Germany, in 2004: standard atmosphere method, two-component adhesive. See Table B.2.

**Table B.2 — Mean of 20 adhesion values for 5 specimens parallel to
and 5 specimens perpendicular to backbone**

Sample	Standard method		With roughened surface	
	Mean adhesion value of finish N/10 mm	Standard deviation	Mean adhesion value of finish N/10 mm	Standard deviation
Leather C	3,2	0,2	2,9	0,2
Leather D	3,7	0,4	4,3	0,6
Leather E	8,2	0,7	8,3	0,7
Leather F	8,8	1,1	9,0	1,3
Leather G	13,3	0,7	13,0	0,8
Leather H	6,9	0,5	7,5	0,5
Leather I	9,8	1,2	9,3	0,6

BSI - British Standards Institution

BSI is the independent national body responsible for preparing British Standards. It presents the UK view on standards in Europe and at the international level. It is incorporated by Royal Charter.

Revisions

British Standards are updated by amendment or revision. Users of British Standards should make sure that they possess the latest amendments or editions.

It is the constant aim of BSI to improve the quality of our products and services. We would be grateful if anyone finding an inaccuracy or ambiguity while using this British Standard would inform the Secretary of the technical committee responsible, the identity of which can be found on the inside front cover. Tel: +44 (0)20 8996 9000. Fax: +44 (0)20 8996 7400.

BSI offers members an individual updating service called PLUS which ensures that subscribers automatically receive the latest editions of standards.

Buying standards

Orders for all BSI, international and foreign standards publications should be addressed to Customer Services. Tel: +44 (0)20 8996 9001. Fax: +44 (0)20 8996 7001 Email: orders@bsigroup.com You may also buy directly using a debit/credit card from the BSI Shop on the Website <http://www.bsigroup.com/shop>

In response to orders for international standards, it is BSI policy to supply the BSI implementation of those that have been published as British Standards, unless otherwise requested.

Information on standards

BSI provides a wide range of information on national, European and international standards through its Library and its Technical Help to Exporters Service. Various BSI electronic information services are also available which give details on all its products and services. Contact Information Centre. Tel: +44 (0)20 8996 7111 Fax: +44 (0)20 8996 7048 Email: info@bsigroup.com

Subscribing members of BSI are kept up to date with standards developments and receive substantial discounts on the purchase price of standards. For details of these and other benefits contact Membership Administration. Tel: +44 (0)20 8996 7002 Fax: +44 (0)20 8996 7001 Email: membership@bsigroup.com

Information regarding online access to British Standards via British Standards Online can be found at <http://www.bsigroup.com/BSOL>

Further information about BSI is available on the BSI website at <http://www.bsigroup.com>.

Copyright

Copyright subsists in all BSI publications. BSI also holds the copyright, in the UK, of the publications of the international standardization bodies. Except as permitted under the Copyright, Designs and Patents Act 1988 no extract may be reproduced, stored in a retrieval system or transmitted in any form or by any means – electronic, photocopying, recording or otherwise – without prior written permission from BSI.

This does not preclude the free use, in the course of implementing the standard, of necessary details such as symbols, and size, type or grade designations. If these details are to be used for any other purpose than implementation then the prior written permission of BSI must be obtained.

Details and advice can be obtained from the Copyright and Licensing Manager. Tel: +44 (0)20 8996 7070 Email: copyright@bsigroup.com