

BS EN ISO 11490:2016



BSI Standards Publication

**Jewellery — Determination
of palladium in palladium
jewellery alloys — Gravimetric
determination with
dimethylglyoxime (ISO
11490:2015)**

National foreword

This British Standard is the UK implementation of EN ISO 11490:2016. It is identical to ISO 11490:2015. It supersedes BS EN ISO 11490:1995 which is withdrawn.

The UK participation in its preparation was entrusted to Technical Committee STI/53, Specifications and test methods for jewellery and horology.

A list of organizations represented on this committee can be obtained on request to its secretary.

This publication does not purport to include all the necessary provisions of a contract. Users are responsible for its correct application.

© The British Standards Institution 2016.
Published by BSI Standards Limited 2016

ISBN 978 0 580 74802 8

ICS 39.060

Compliance with a British Standard cannot confer immunity from legal obligations.

This British Standard was published under the authority of the Standards Policy and Strategy Committee on 31 October 2016.

Amendments/corrigenda issued since publication

Date	Text affected
------	---------------

EUROPEAN STANDARD

EN ISO 11490

NORME EUROPÉENNE

EUROPÄISCHE NORM

October 2016

ICS 39.060

Supersedes EN ISO 11490:1995

English Version

Jewellery - Determination of palladium in palladium jewellery alloys - Gravimetric determination with dimethylglyoxime (ISO 11490:2015)

Joellerie - Dosage du palladium dans les alliages de palladium pour la bijouterie-joellerie - Dosage gravimétrique par la diméthylglyoxime (ISO 11490:2015)

Schmuck - Bestimmung von Palladium in Palladium-Schmucklegierungen - Gravimetrische Bestimmung mit Dimethylglyoxim (ISO 11490:2015)

This European Standard was approved by CEN on 26 August 2016.

CEN members are bound to comply with the CEN/CENELEC Internal Regulations which stipulate the conditions for giving this European Standard the status of a national standard without any alteration. Up-to-date lists and bibliographical references concerning such national standards may be obtained on application to the CEN-CENELEC Management Centre or to any CEN member.

This European Standard exists in three official versions (English, French, German). A version in any other language made by translation under the responsibility of a CEN member into its own language and notified to the CEN-CENELEC Management Centre has the same status as the official versions.

CEN members are the national standards bodies of Austria, Belgium, Bulgaria, Croatia, Cyprus, Czech Republic, Denmark, Estonia, Finland, Former Yugoslav Republic of Macedonia, France, Germany, Greece, Hungary, Iceland, Ireland, Italy, Latvia, Lithuania, Luxembourg, Malta, Netherlands, Norway, Poland, Portugal, Romania, Slovakia, Slovenia, Spain, Sweden, Switzerland, Turkey and United Kingdom.



EUROPEAN COMMITTEE FOR STANDARDIZATION
COMITÉ EUROPÉEN DE NORMALISATION
EUROPÄISCHES KOMITEE FÜR NORMUNG

CEN-CENELEC Management Centre: Avenue Marnix 17, B-1000 Brussels

European foreword

The text of ISO 11490:2015 has been prepared by Technical Committee ISO/TC 174 "Jewellery" of the International Organization for Standardization (ISO) and has been taken over as EN ISO 11490:2016.

This European Standard shall be given the status of a national standard, either by publication of an identical text or by endorsement, at the latest by April 2017, and conflicting national standards shall be withdrawn at the latest by April 2017.

Attention is drawn to the possibility that some of the elements of this document may be the subject of patent rights. CEN [and/or CENELEC] shall not be held responsible for identifying any or all such patent rights.

This document supersedes EN ISO 11490:1995.

According to the CEN-CENELEC Internal Regulations, the national standards organizations of the following countries are bound to implement this European Standard: Austria, Belgium, Bulgaria, Croatia, Cyprus, Czech Republic, Denmark, Estonia, Finland, Former Yugoslav Republic of Macedonia, France, Germany, Greece, Hungary, Iceland, Ireland, Italy, Latvia, Lithuania, Luxembourg, Malta, Netherlands, Norway, Poland, Portugal, Romania, Slovakia, Slovenia, Spain, Sweden, Switzerland, Turkey and the United Kingdom.

Endorsement notice

The text of ISO 11490:2015 has been approved by CEN as EN ISO 11490:2016 without any modification.

Contents		Page
Foreword		iv
Introduction		v
1 Scope		1
2 Normative references		1
3 Principle		1
4 Reagents		1
5 Apparatus		2
6 Sampling		2
7 Procedure		2
8 Calculation and expression of results		3
8.1 Calculation.....		3
8.2 Repeatability.....		4
9 Test report		4
Annex A (informative) Reduction apparatus according to Rose		5
Bibliography		6

Foreword

ISO (the International Organization for Standardization) is a worldwide federation of national standards bodies (ISO member bodies). The work of preparing International Standards is normally carried out through ISO technical committees. Each member body interested in a subject for which a technical committee has been established has the right to be represented on that committee. International organizations, governmental and non-governmental, in liaison with ISO, also take part in the work. ISO collaborates closely with the International Electrotechnical Commission (IEC) on all matters of electrotechnical standardization.

The procedures used to develop this document and those intended for its further maintenance are described in the ISO/IEC Directives, Part 1. In particular the different approval criteria needed for the different types of ISO documents should be noted. This document was drafted in accordance with the editorial rules of the ISO/IEC Directives, Part 2 (see www.iso.org/directives).

Attention is drawn to the possibility that some of the elements of this document may be the subject of patent rights. ISO shall not be held responsible for identifying any or all such patent rights. Details of any patent rights identified during the development of the document will be in the Introduction and/or on the ISO list of patent declarations received (see www.iso.org/patents).

Any trade name used in this document is information given for the convenience of users and does not constitute an endorsement.

For an explanation on the meaning of ISO specific terms and expressions related to conformity assessment, as well as information about ISO's adherence to the WTO principles in the Technical Barriers to Trade (TBT), see the following URL: [Foreword — Supplementary Information](#).

The committee responsible for this document is ISO/TC 174, *Jewellery*.

This second edition cancels and replaces the first edition (ISO 11490:1995), which has been technically revised with the following changes:

- a) addition of an analytical balance in [Clause 5](#);
- b) change of requirement for sampling in [Clause 6](#);
- c) addition of a warning in [Clause 7](#) that suitable health and safety procedures should be followed;
- d) standard editorially revised.

Introduction

The following definitions apply in understanding how to implement an ISO International Standard and other normative ISO deliverables (TS, PAS, IWA):

- “shall” indicates a requirement;
- “should” indicates a recommendation;
- “may” is used to indicate that something is permitted;
- “can” is used to indicate that something is possible, for example, that an organization or individual is able to do something.

ISO/IEC Directives, Part 2 (sixth edition, 2011), 3.3.1 defines a requirement as an “expression in the content of a document conveying criteria to be fulfilled if compliance with the document is to be claimed and from which no deviation is permitted.”

ISO/IEC Directives, Part 2 (sixth edition, 2011), 3.3.2 defines a recommendation as an “expression in the content of a document conveying that among several possibilities, one is recommended as particularly suitable without mentioning or excluding others, or that a certain course of action is preferred, but not necessarily required, or that (in the negative form) a certain possibility or course of action is deprecated, but not prohibited.”

Jewellery — Determination of palladium in palladium jewellery alloys — Gravimetric determination with dimethylglyoxime

1 Scope

This International Standard specifies a gravimetric method for the determination of palladium in palladium jewellery alloys, preferably within the range of fineness stated in ISO 9202.

These alloys may contain silver, indium, gallium, copper, cobalt, nickel, tin, and ruthenium. Coprecipitated elements have to be determined by a suitable method and a correction applied.

2 Normative references

The following documents, in whole or in part, are normatively referenced in this document and are indispensable for its application. For dated references, only the edition cited applies. For undated references, the latest edition of the referenced document (including any amendments) applies.

ISO 11596, *Jewellery — Sampling of precious metal alloys for and in jewellery and associated products*

3 Principle

The sample is dissolved in aqua regia. Palladium is precipitated with dimethylglyoxime. If present, silver is separated as silver chloride. The palladium dimethylglyoxime compound is converted to metallic palladium by ignition and the latter is then determined gravimetrically.

4 Reagents

4.1 During the analysis, unless otherwise stated, use only reagents of recognized analytical grade and only distilled water or water of equivalent purity.

4.2 Nitric acid (HNO₃), approximately 65 % to 70 % HNO₃ (mass fraction).

4.3 Hydrochloric acid (HCl), 30 % to 37 % HCl (mass fraction).

4.4 Diluted hydrochloric acid, 8,5 % (mass fraction).

4.5 Dimethylglyoxime solution.

Dissolve 10 g of dimethylglyoxime in 1 000 ml of ethanol.

4.6 Ammonium chloride.

4.7 Diluted nitric acid, 1,39 %.

Cautiously add 10 ml of nitric acid ([4.2](#)) to 1 000 ml of water and mix.

4.8 Hydrofluoric acid, 40 % (mass fraction).

4.9 Diluted sulphuric acid, 50 % (mass fraction).

4.10 Reducing gas, such as hydrogen or a hydrogen/nitrogen mixture.

4.11 Inert gas under pressure, carbon dioxide or nitrogen are usual.

4.12 Aqua regia.

Mix three volumes of hydrochloric acid (4.3) and one volume of nitric acid (4.2).

5 Apparatus

5.1 Customary laboratory apparatus.

5.2 Reduction apparatus, see [Figure A.1](#).

5.3 Platinum dishes, of volume 10 ml.

5.4 AAS or ICP-OES, or other means of determining traces of metal.

5.5 Muffle furnace, capable of attaining at least 900 °C.

5.6 Ashless filter paper, capable of retaining particles greater than 3 µm.

5.7 Analytical balance, with a reading accuracy of 0,01 mg.

6 Sampling

The sampling procedure shall be performed in accordance with ISO 11596.

7 Procedure

WARNING — Suitable health and safety procedures should be followed.

7.1 Flatten the sample to less than 0,5 mm thick and weigh a sample containing 150 mg to 200 mg of palladium accurately to 0,01 mg. Transfer it to an 800 ml tall-form beaker. Add 10 ml of nitric acid (4.2) and heat at 70 °C to 80 °C for 20 min in the beaker covered with a watch glass before adding 30 ml of hydrochloric acid (4.3) to complete the dissolution.

7.2 If insoluble silver chloride forms, break this up with a glass rod to ensure that all the metal is dissolved.

7.3 Remove the watch glass and gently evaporate to dryness. Dissolve the residue in 10 ml of hydrochloric acid (4.3) and dilute to about 100 ml.

7.4 If a precipitate forms, allow it to settle for 12 h in a dark place. Filter and wash with dilute nitric acid (4.7), retaining the precipitate for the determination of traces of palladium using suitable apparatus (5.4).

7.5 Add 20 ml of hydrochloric acid to the clear solution from 7.3 (or filtrate and washings from 7.4). Dilute to approximately 400 ml, cool to 15 °C, and add dimethylglyoxime solution in 5 ml portions up to a total of 30 ml for every expected 100 mg of palladium.

7.6 Leave to settle for 1 h, filter and wash with dimethylglyoxime solution (4.5) diluted 10 times with water. Retain the combined filtrate and washes for determination of palladium using suitable apparatus (5.4) and correct the final result.

7.7 Transfer the precipitate and filter to a tared porcelain crucible. Tap the filter to obtain a flat surface and dry in an oven at 110 °C to 120 °C for 3 h. Cover with a layer of ammonium chloride (4.6) about 3 mm thick (about 4 g for a crucible of diameter 40 mm) to prevent loss of palladium during ignition.

7.8 Heat the crucible gently (for about 40 min) first to char the paper and then to decompose the palladium complex and drive off the ammonium chloride. When all fuming has ceased, ignite at 800 °C ± 50 °C for 1 h.

NOTE The ammonium chloride decomposes at 340 °C.

7.9 The partially oxidized palladium is reduced to the metallic state by heating in the presence of reducing gas (4.10) and allowing to cool in an inert gas atmosphere (4.11).

7.10 Weigh the product to obtain an approximate mass of palladium.

7.11 Transfer the impure palladium to a platinum dish (5.3). Moisten with hydrofluoric acid (4.8) and add three drops of dilute sulfuric acid (4.9). Heat until fumes start to evolve from the solution, cool, then extract the residue with a little hot water. Filter and wash with water. Combine the filtrate and washes with those from the previous filtration. Transfer the palladium and filter to a crucible, ignite at approximately 700 °C, and reduce as described in 7.9. Reweigh to obtain the final mass.

7.12 If contamination of the palladium is suspected, it shall be dissolved in aqua regia (4.12). The elements determined by a spectrometric method and their mass subtracted from the final mass of palladium, or the palladium, shall be cleaned by repeating the process in 7.1 to 7.11.

7.13 The combined filtrates and washes are tested for palladium by instrumental means, usually an AAS or ICP-OES (5.4). Excess dimethylglyoxime is destroyed by evaporation to dryness, then treating the residue with aqua regia (4.12). The resulting solution is compared with standard palladium solutions containing equivalent quantities of acids and spectroscopic buffers.

8 Calculation and expression of results

8.1 Calculation

If the final weighed mass contains exclusively palladium, calculate the palladium content W_{Pd} in parts by mass per thousand (‰) using Formula (1).

$$W_{Pd} = \frac{m_3 + m_2}{m_1} \times 10^3 \quad (1)$$

where

m_1 is the mass, in milligrams, of the sample;

m_2 is the mass, in milligrams, in the filtrate;

m_3 is the final mass, in milligrams.

If the final weighed mass contains other elements, calculate the palladium content W_{Pd} in parts by mass per thousand (‰) using Formula (2).

$$W_{\text{Pd}} = \frac{m_3 + m_2 - m_x}{m_1} \times 10^3 \quad (2)$$

where

m_x is the total mass, in milligrams, of other elements.

The palladium content W_{Pd} in parts by mass per thousand (‰) is corrected for the mass m_y of palladium in the silver chloride precipitated in 7.4 using Formula (3).

$$W_{\text{Pd}} = \frac{m_3 + m_2 - m_x + m_y}{m_1} \times 10^3 \quad (3)$$

where

m_y is the mass, in milligrams, of palladium in the silver chloride.

8.2 Repeatability

The results of duplicate determinations shall correspond to better than five parts per mass per thousand (‰) of palladium. If the variation is greater than this, the assays shall be repeated.

9 Test report

The test report shall include the following information:

- a) identification of the sample including source, date of receipt, form of sample;
- b) sampling procedure;
- c) the method used by reference to this International Standard, i.e. ISO 11490;
- d) palladium content of the sample, in parts by mass per thousand (‰), as single values and mean values;
- e) if relevant, any deviations from the method specified in this International Standard;
- f) any unusual features observed during the determination;
- g) date of test;
- h) identification of the laboratory carrying out this analysis;
- i) signature of the laboratory manager and operator.

Annex A (informative)

Reduction apparatus according to Rose

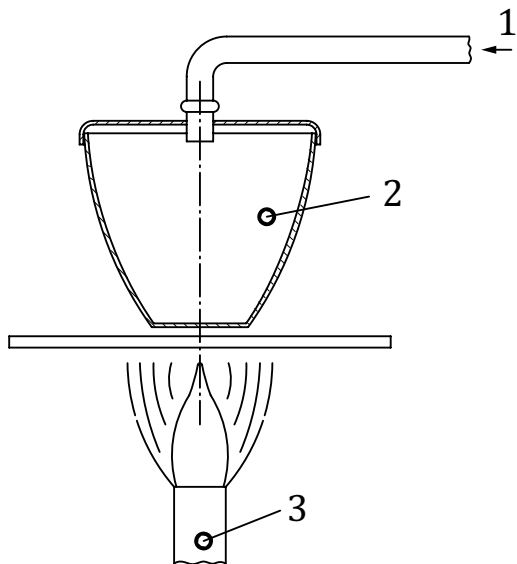

Key

- 1 gas flow
- 2 lidded Rose crucible
- 3 gas burner

Figure A.1 — Reduction apparatus

Bibliography

- [1] ISO 9202:1991, *Jewellery — Fineness of precious metal alloys*

British Standards Institution (BSI)

BSI is the national body responsible for preparing British Standards and other standards-related publications, information and services.

BSI is incorporated by Royal Charter. British Standards and other standardization products are published by BSI Standards Limited.

About us

We bring together business, industry, government, consumers, innovators and others to shape their combined experience and expertise into standards-based solutions.

The knowledge embodied in our standards has been carefully assembled in a dependable format and refined through our open consultation process. Organizations of all sizes and across all sectors choose standards to help them achieve their goals.

Information on standards

We can provide you with the knowledge that your organization needs to succeed. Find out more about British Standards by visiting our website at bsigroup.com/standards or contacting our Customer Services team or Knowledge Centre.

Buying standards

You can buy and download PDF versions of BSI publications, including British and adopted European and international standards, through our website at bsigroup.com/shop, where hard copies can also be purchased.

If you need international and foreign standards from other Standards Development Organizations, hard copies can be ordered from our Customer Services team.

Copyright in BSI publications

All the content in BSI publications, including British Standards, is the property of and copyrighted by BSI or some person or entity that owns copyright in the information used (such as the international standardization bodies) and has formally licensed such information to BSI for commercial publication and use.

Save for the provisions below, you may not transfer, share or disseminate any portion of the standard to any other person. You may not adapt, distribute, commercially exploit, or publicly display the standard or any portion thereof in any manner whatsoever without BSI's prior written consent.

Storing and using standards

Standards purchased in soft copy format:

- A British Standard purchased in soft copy format is licensed to a sole named user for personal or internal company use only.
- The standard may be stored on more than 1 device provided that it is accessible by the sole named user only and that only 1 copy is accessed at any one time.
- A single paper copy may be printed for personal or internal company use only.

Standards purchased in hard copy format:

- A British Standard purchased in hard copy format is for personal or internal company use only.
- It may not be further reproduced – in any format – to create an additional copy. This includes scanning of the document.

If you need more than 1 copy of the document, or if you wish to share the document on an internal network, you can save money by choosing a subscription product (see 'Subscriptions').

Reproducing extracts

For permission to reproduce content from BSI publications contact the BSI Copyright & Licensing team.

Subscriptions

Our range of subscription services are designed to make using standards easier for you. For further information on our subscription products go to bsigroup.com/subscriptions.

With **British Standards Online (BSOL)** you'll have instant access to over 55,000 British and adopted European and international standards from your desktop. It's available 24/7 and is refreshed daily so you'll always be up to date.

You can keep in touch with standards developments and receive substantial discounts on the purchase price of standards, both in single copy and subscription format, by becoming a **BSI Subscribing Member**.

PLUS is an updating service exclusive to BSI Subscribing Members. You will automatically receive the latest hard copy of your standards when they're revised or replaced.

To find out more about becoming a BSI Subscribing Member and the benefits of membership, please visit bsigroup.com/shop.

With a **Multi-User Network Licence (MUNL)** you are able to host standards publications on your intranet. Licences can cover as few or as many users as you wish. With updates supplied as soon as they're available, you can be sure your documentation is current. For further information, email subscriptions@bsigroup.com.

Revisions

Our British Standards and other publications are updated by amendment or revision.

We continually improve the quality of our products and services to benefit your business. If you find an inaccuracy or ambiguity within a British Standard or other BSI publication please inform the Knowledge Centre.

Useful Contacts

Customer Services

Tel: +44 345 086 9001

Email (orders): orders@bsigroup.com

Email (enquiries): cservices@bsigroup.com

Subscriptions

Tel: +44 345 086 9001

Email: subscriptions@bsigroup.com

Knowledge Centre

Tel: +44 20 8996 7004

Email: knowledgecentre@bsigroup.com

Copyright & Licensing

Tel: +44 20 8996 7070

Email: copyright@bsigroup.com

BSI Group Headquarters

389 Chiswick High Road London W4 4AL UK