

Building construction — Sealants — Determination of resistance to compression

The European Standard EN ISO 11432:2005 has the status of a
British Standard

ICS 91.100.50

National foreword

This British Standard is the official English language version of EN ISO 11432:2005. It is identical with ISO 11432:2005. It supersedes BS EN ISO 11432:1998 which is withdrawn.

The UK participation in its preparation was entrusted to Technical Committee B/547, Sealants for building and construction, which has the responsibility to:

- aid enquirers to understand the text;
- present to the responsible international/European committee any enquiries on the interpretation, or proposals for change, and keep UK interests informed;
- monitor related international and European developments and promulgate them in the UK.

A list of organizations represented on this committee can be obtained on request to its secretary.

Additional information

EN ISO 11432:2005 is a test method useful in the determination of compressive properties and one of the procedures used for classifying construction sealants within BS EN ISO 11600:2003.

Cross-references

The British Standards which implement international or European publications referred to in this document may be found in the *BSI Catalogue* under the section entitled “International Standards Correspondence Index”, or by using the “Search” facility of the *BSI Electronic Catalogue* or of British Standards Online.

This publication does not purport to include all the necessary provisions of a contract. Users are responsible for its correct application.

Compliance with a British Standard does not of itself confer immunity from legal obligations.

Summary of pages

This document comprises a front cover, an inside front cover, the EN ISO title page, the EN ISO foreword page, the ISO title page, pages ii to iv, pages 1 to 5 and a back cover.

The BSI copyright notice displayed in this document indicates when the document was last issued.

Amendments issued since publication

Amd. No.	Date	Comments

This British Standard was published under the authority of the Standards Policy and Strategy Committee on 17 November 2005

© BSI 17 November 2005

English Version

**Building construction - Sealants - Determination of resistance to
compression (ISO 11432:2005)**

Construction immobilière - Mastics - Détermination de la
résistance à la compression des mastics (ISO 11432:2005)

Hochbau - Fugendichtstoffe - Bestimmung des
Druckwiderstands (ISO 11432:2005)

This European Standard was approved by CEN on 20 June 2005.

CEN members are bound to comply with the CEN/CENELEC Internal Regulations which stipulate the conditions for giving this European Standard the status of a national standard without any alteration. Up-to-date lists and bibliographical references concerning such national standards may be obtained on application to the Central Secretariat or to any CEN member.

This European Standard exists in three official versions (English, French, German). A version in any other language made by translation under the responsibility of a CEN member into its own language and notified to the Central Secretariat has the same status as the official versions.

CEN members are the national standards bodies of Austria, Belgium, Cyprus, Czech Republic, Denmark, Estonia, Finland, France, Germany, Greece, Hungary, Iceland, Ireland, Italy, Latvia, Lithuania, Luxembourg, Malta, Netherlands, Norway, Poland, Portugal, Slovakia, Slovenia, Spain, Sweden, Switzerland and United Kingdom.



EUROPEAN COMMITTEE FOR STANDARDIZATION
COMITÉ EUROPÉEN DE NORMALISATION
EUROPÄISCHES KOMITEE FÜR NORMUNG

Management Centre: rue de Stassart, 36 B-1050 Brussels

EN ISO 11432:2005

Foreword

This document (EN ISO 11432:2005) has been prepared by Technical Committee ISO/TC 59 "Building construction" in collaboration with CMC.

This European Standard shall be given the status of a national standard, either by publication of an identical text or by endorsement, at the latest by January 2006, and conflicting national standards shall be withdrawn at the latest by January 2006.

This document supersedes EN ISO 11432:1997.

According to the CEN/CENELEC Internal Regulations, the national standards organizations of the following countries are bound to implement this European Standard: Austria, Belgium, Cyprus, Czech Republic, Denmark, Estonia, Finland, France, Germany, Greece, Hungary, Iceland, Ireland, Italy, Latvia, Lithuania, Luxembourg, Malta, Netherlands, Norway, Poland, Portugal, Slovakia, Slovenia, Spain, Sweden, Switzerland and United Kingdom.

Endorsement notice

The text of ISO 11432:2005 has been approved by CEN as EN ISO 11432:2005 without any modifications.

INTERNATIONAL
STANDARD

ISO
11432

Second edition
2005-07-01

**Building construction — Sealants —
Determination of resistance to
compression**

*Construction immobilière — Mastics — Détermination de la résistance à
la compression des mastics*



Reference number
ISO 11432:2005(E)

Contents

Page

Foreword..... iv

1 **Scope** 1

2 **Normative references** 1

3 **Terms and definitions**..... 1

4 **Principle**..... 1

5 **Apparatus** 1

6 **Preparation of test specimens** 2

7 **Conditioning of test specimens** 2

8 **Test procedure** 3

9 **Expression of results** 3

10 **Test report**..... 3

Licensed copy: Lee Shau Kee Library, HKUST, Version correct as of 03/01/2015, (c) The British Standards Institution 2013

Foreword

ISO (the International Organization for Standardization) is a worldwide federation of national standards bodies (ISO member bodies). The work of preparing International Standards is normally carried out through ISO technical committees. Each member body interested in a subject for which a technical committee has been established has the right to be represented on that committee. International organizations, governmental and non-governmental, in liaison with ISO, also take part in the work. ISO collaborates closely with the International Electrotechnical Commission (IEC) on all matters of electrotechnical standardization.

International Standards are drafted in accordance with the rules given in the ISO/IEC Directives, Part 2.

The main task of technical committees is to prepare International Standards. Draft International Standards adopted by the technical committees are circulated to the member bodies for voting. Publication as an International Standard requires approval by at least 75 % of the member bodies casting a vote.

Attention is drawn to the possibility that some of the elements of this document may be the subject of patent rights. ISO shall not be held responsible for identifying any or all such patent rights.

ISO 11432 was prepared by Technical Committee ISO/TC 59, *Building construction*, Subcommittee SC 8, *Jointing products*.

This second edition cancels and replaces the first edition (ISO 11432:1993), Clauses 5, 6 and 7 of which have been technically revised.

Building construction — Sealants — Determination of resistance to compression

1 Scope

This International Standard specifies a method for the determination of the resistance to compression of sealants used in joints in building construction.

2 Normative references

The following referenced documents are indispensable for the application of this document. For dated references, only the edition cited applies. For undated references, the latest edition of the referenced document (including any amendments) applies.

ISO 6927, *Building construction — Jointing products — Sealants — Vocabulary*

ISO 13640, *Building construction — Jointing products — Specifications for test substrates*

3 Terms and definitions

For the purposes of this document, the definitions given in ISO 6927 apply.

4 Principle

Test specimens, in which the sealant to be tested is adhered to two parallel substrate surfaces, are compressed by a defined percentage of the original width and the force recorded.

5 Apparatus

5.1 Substrate materials, used for the preparation of test specimens, are defined in ISO 13640, *Specification for test substrates*. The materials shall be selected from mortar and/or anodized aluminium and/or glass. Other substrate materials may be used as agreed by the parties concerned. For each test specimen, two substrate pieces of the same material are required; with dimensions as shown in Figures 1 and 2. Test substrates of other dimensions may be used, but then the dimensions of the sealant bead and the area of adhesion shall be the same as those shown in Figures 1 and 2.

5.2 Spacers, for the preparation of the test specimens, of cross-sections (12 mm × 12 mm) with anti-adherent surface.

5.3 Anti-adherent substrate, for the preparation of test specimens, e.g. polyethylene (PE) film, preferably according to the advice of the sealant manufacturer.

5.4 Ventilated convection-type oven, capable of operating at (70 ± 2) °C for conditioning according to method B.

5.5 Container, for water immersion of the specimen for conditioning according to method B.

5.6 Tensile test machine, capable of compressing the test specimens at a rate of $(5,5 \pm 0,7)$ mm/min.

6 Preparation of test specimens

The sealant and the test substrate shall be brought to (23 ± 2) °C. For each substrate material, three test specimens shall be prepared.

For each test specimen, two substrates (5.1) and two spacers (5.2) shall be assembled (see Figures 1 and 2) and set on the anti-adherent substrate (5.3).

The instructions of the sealant manufacturer shall be followed concerning, for instance, whether a primer is to be used and the mixing procedure for multi-component sealants. The hollow volume formed by the substrates shall be filled with the sealant.

The following precautions shall be taken:

- a) the formation of air bubbles shall be avoided;
- b) the sealant shall be pressed to the contact surfaces of the substrates;
- c) the sealant surface shall be trimmed so that it is flush with the faces of the substrates and the spacers.

The test specimens shall be set on the edge of one of the supports and the anti-adherent substrate shall be removed as soon as possible. The test specimens shall be kept in this position to allow curing or optimum drying of the sealant.

The spacers shall be maintained in place during conditioning.

7 Conditioning of test specimens

7.1 General

The test specimens shall be conditioned either according to method A (see 7.2) or method B (see 7.3).

7.2 Conditioning method A

The test specimens shall be conditioned for 28 days at (23 ± 2) °C and (50 ± 5) % relative humidity.

7.3 Conditioning method B

First the test specimens shall be conditioned according to method A and subsequently subjected three times to the following storage cycle:

- a) three days in the oven (5.4) at (70 ± 2) °C;
- b) one day in distilled water (5.5) at (23 ± 2) °C;
- c) two days in the oven (5.4) at (70 ± 2) °C;
- d) one day in distilled water (5.5) at (23 ± 2) °C.

This cycle may be carried out alternatively in the sequence: c), d), a), b).

After conditioning according to method B, the test specimens shall be stored for a further period of 24 h at (23 ± 2) °C and (50 ± 5) % relative humidity before testing.

NOTE Conditioning method B is a normal conditioning procedure using the influence of heat and water. It is not intended to give information on the durability of the sealant.

8 Test procedure

The test shall be carried out at $(23 \pm 2) ^\circ\text{C}$ and $(50 \pm 5) \%$ relative humidity. The spacers (5.2) shall be removed. The test specimens shall be placed in the tensile test machine (5.6) and compressed at a rate of $(5,5 \pm 0,7) \text{ mm/min}$ to 75 % or 80 % of the initial width, or by any other percentage as agreed by the parties concerned.

The following table gives the correspondence in millimetres of the percentage compression for a test specimen of 12 mm initial width.

**Table 1 — Correspondence of compression values
original width 12 mm**

Compressed width relative to the original width %	Compression %	Width after compression mm
75	25	9,0
80	20	9,6

The force, expressed in newtons, required for the appropriate compression shall be recorded.

9 Expression of results

For each test specimen, the secant compression modulus shall be calculated, for the chosen compression amplitude, rounded to $0,01 \text{ N/mm}^2$, using the equation:

$$\text{Secant compression modulus} = \text{Force at chosen compression (expressed in N)} / \text{initial cross-section area (expressed in mm}^2\text{)}$$

The arithmetic mean of the three secant compression modulus values shall be calculated, rounded to $0,01 \text{ N/mm}^2$.

10 Test report

The test report shall contain the following information:

- a) the test laboratory's name and the date of testing;
- b) a reference to this International Standard;
- c) name, type (chemical family) and colour of sealant;
- d) batch of sealant from which the test specimens were produced;
- e) substrate material used;
- f) the primer used, if applicable;
- g) the method of conditioning (see Clause 7);
- h) the percentage compression (see Clause 8);
- i) the secant compression modulus of each test specimen (N/mm^2);
- j) the arithmetic mean of the three secant compression modulus;
- k) any deviations from this International Standard.

Dimensions in millimetres

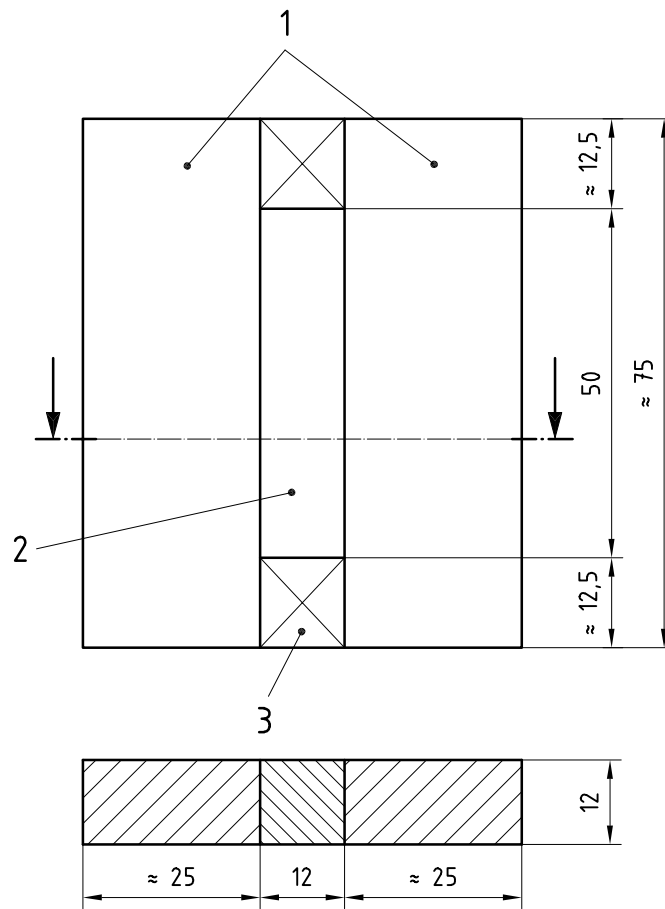

Key

- 1 mortar substrates
- 2 sealant
- 3 spacers (5.2)

Figure 1 — Test specimens with mortar substrates

Dimensions in millimetres

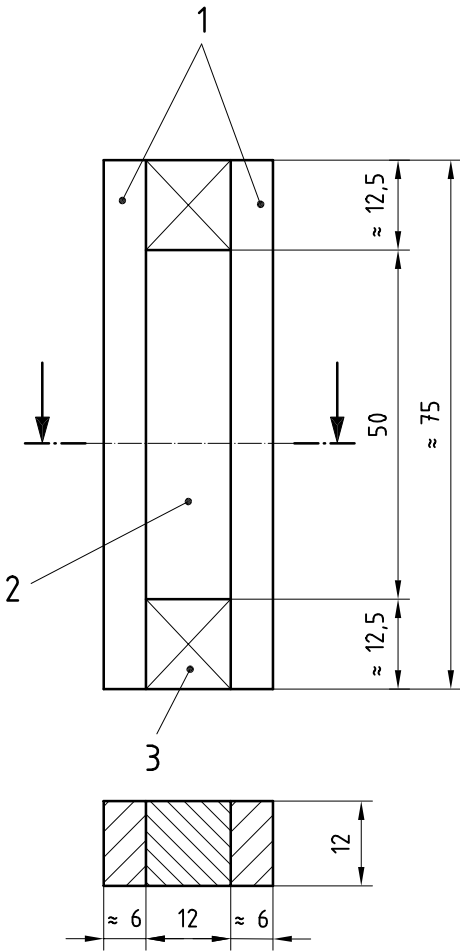

- Key**
- 1 anodized aluminium or glass substrates
 - 2 sealant
 - 3 spacers (5.2)

Figure 2 — Test specimens with anodized aluminium or glass substrates

BSI — British Standards Institution

BSI is the independent national body responsible for preparing British Standards. It presents the UK view on standards in Europe and at the international level. It is incorporated by Royal Charter.

Revisions

British Standards are updated by amendment or revision. Users of British Standards should make sure that they possess the latest amendments or editions.

It is the constant aim of BSI to improve the quality of our products and services. We would be grateful if anyone finding an inaccuracy or ambiguity while using this British Standard would inform the Secretary of the technical committee responsible, the identity of which can be found on the inside front cover.
Tel: +44 (0)20 8996 9000. Fax: +44 (0)20 8996 7400.

BSI offers members an individual updating service called PLUS which ensures that subscribers automatically receive the latest editions of standards.

Buying standards

Orders for all BSI, international and foreign standards publications should be addressed to Customer Services. Tel: +44 (0)20 8996 9001.
Fax: +44 (0)20 8996 7001. Email: orders@bsi-global.com. Standards are also available from the BSI website at <http://www.bsi-global.com>.

In response to orders for international standards, it is BSI policy to supply the BSI implementation of those that have been published as British Standards, unless otherwise requested.

Information on standards

BSI provides a wide range of information on national, European and international standards through its Library and its Technical Help to Exporters Service. Various BSI electronic information services are also available which give details on all its products and services. Contact the Information Centre.
Tel: +44 (0)20 8996 7111. Fax: +44 (0)20 8996 7048. Email: info@bsi-global.com.

Subscribing members of BSI are kept up to date with standards developments and receive substantial discounts on the purchase price of standards. For details of these and other benefits contact Membership Administration.
Tel: +44 (0)20 8996 7002. Fax: +44 (0)20 8996 7001.
Email: membership@bsi-global.com.

Information regarding online access to British Standards via British Standards Online can be found at <http://www.bsi-global.com/bsonline>.

Further information about BSI is available on the BSI website at <http://www.bsi-global.com>.

Copyright

Copyright subsists in all BSI publications. BSI also holds the copyright, in the UK, of the publications of the international standardization bodies. Except as permitted under the Copyright, Designs and Patents Act 1988 no extract may be reproduced, stored in a retrieval system or transmitted in any form or by any means – electronic, photocopying, recording or otherwise – without prior written permission from BSI.

This does not preclude the free use, in the course of implementing the standard, of necessary details such as symbols, and size, type or grade designations. If these details are to be used for any other purpose than implementation then the prior written permission of BSI must be obtained.

Details and advice can be obtained from the Copyright & Licensing Manager.
Tel: +44 (0)20 8996 7070. Fax: +44 (0)20 8996 7553.
Email: copyright@bsi-global.com.