



BSI Standards Publication

**Acoustics — Noise emitted
by machinery and equipment
— Determination of emission
sound pressure levels at a work
station and at other specified
positions applying accurate
environmental corrections (ISO
11204:2010)**

National foreword

This British Standard is the UK implementation of EN ISO 11204:2010. It supersedes BS EN ISO 11204:2009 which is withdrawn.

The UK participation in its preparation was entrusted to Technical Committee EH/1/4, Machinery noise.

A list of organizations represented on this committee can be obtained on request to its secretary.

This publication does not purport to include all the necessary provisions of a contract. Users are responsible for its correct application.

© BSI 2010

ISBN 978 0 580 53887 2

ICS 17.140.20

Compliance with a British Standard cannot confer immunity from legal obligations.

This British Standard was published under the authority of the Standards Policy and Strategy Committee on 31 August 2010

Amendments issued since publication

Date	Text affected
------	---------------

English Version

Acoustics - Noise emitted by machinery and equipment -
Determination of emission sound pressure levels at a work
station and at other specified positions applying accurate
environmental corrections (ISO 11204:2010)

Acoustique - Bruit émis par les machines et équipements -
Détermination des niveaux de pression acoustique
d'émission au poste de travail et en d'autres positions
spécifiées en appliquant des corrections d'environnement
exactes (ISO 11204:2010)

Akustik - Geräuschabstrahlung von Maschinen und
Geräten - Bestimmung von Emissions-Schalldruckpegeln
am Arbeitsplatz und an anderen festgelegten Orten unter
Anwendung exakter Umgebungskorrekturen (ISO
11204:2010)

This European Standard was approved by CEN on 22 April 2010.

CEN members are bound to comply with the CEN/CENELEC Internal Regulations which stipulate the conditions for giving this European Standard the status of a national standard without any alteration. Up-to-date lists and bibliographical references concerning such national standards may be obtained on application to the CEN Management Centre or to any CEN member.

This European Standard exists in three official versions (English, French, German). A version in any other language made by translation under the responsibility of a CEN member into its own language and notified to the CEN Management Centre has the same status as the official versions.

CEN members are the national standards bodies of Austria, Belgium, Bulgaria, Croatia, Cyprus, Czech Republic, Denmark, Estonia, Finland, France, Germany, Greece, Hungary, Iceland, Ireland, Italy, Latvia, Lithuania, Luxembourg, Malta, Netherlands, Norway, Poland, Portugal, Romania, Slovakia, Slovenia, Spain, Sweden, Switzerland and United Kingdom.



EUROPEAN COMMITTEE FOR STANDARDIZATION
COMITÉ EUROPÉEN DE NORMALISATION
EUROPÄISCHES KOMITEE FÜR NORMUNG

Management Centre: Avenue Marnix 17, B-1000 Brussels

Foreword

This document (EN ISO 11204:2010) has been prepared by Technical Committee ISO/TC 43 “Acoustics” in collaboration with Technical Committee CEN/TC 211 “Acoustics” the secretariat of which is held by DS.

This European Standard shall be given the status of a national standard, either by publication of an identical text or by endorsement, at the latest by November 2010, and conflicting national standards shall be withdrawn at the latest by November 2010.

Attention is drawn to the possibility that some of the elements of this document may be the subject of patent rights. CEN [and/or CENELEC] shall not be held responsible for identifying any or all such patent rights.

This document supersedes EN ISO 11204:2009.

This document has been prepared under a mandate given to CEN by the European Commission and the European Free Trade Association, and supports essential requirements of EU Directive.

For relationship with EU Directive, see informative Annex ZA, which is an integral part of this document.

According to the CEN/CENELEC Internal Regulations, the national standards organizations of the following countries are bound to implement this European Standard: Austria, Belgium, Bulgaria, Croatia, Cyprus, Czech Republic, Denmark, Estonia, Finland, France, Germany, Greece, Hungary, Iceland, Ireland, Italy, Latvia, Lithuania, Luxembourg, Malta, Netherlands, Norway, Poland, Portugal, Romania, Slovakia, Slovenia, Spain, Sweden, Switzerland and the United Kingdom.

Endorsement notice

The text of ISO 11204:2010 has been approved by CEN as a EN ISO 11204:2010 without any modification.

Annex ZA (informative)

Relationship between this European Standard and the Essential Requirements of EU Directive 2006/42/EC

This European Standard has been prepared under a mandate given to CEN by the European Commission and the European Free Trade Association to provide a means of conforming to Essential Requirements of the New Approach Directive 2006/42/EC on machinery.

Once this standard is cited in the Official Journal of the European Union under that Directive and has been implemented as a national standard in at least one Member State, compliance with the normative clauses of this standard confers, within the limits of the scope of this standard, a presumption of conformity with the corresponding Essential Requirements of that Directive and associated EFTA regulations.

WARNING — Other requirements and other EU Directives may be applicable to the product(s) falling within the scope of this standard.

Contents

Page

Foreword	iv
Introduction	v
1 Scope	1
2 Normative references	2
3 Terms and definitions	3
4 Instrumentation	7
5 Test environment	8
6 Measured quantities	10
7 Quantities to be determined	11
8 Mounting and operation of source under test	11
9 Microphone positions	13
10 Measurements	15
11 Measurement uncertainty	17
12 Information to be recorded	20
13 Test report	21
Annex A (normative) Environmental correction for a work station — Determination of the local environmental correction, K_3	23
Annex B (normative) Criteria for background noise for measurements in frequency bands	26
Annex C (informative) Guidance on the development of information on measurement uncertainty	28
Annex D (informative) Principles of the methodology	34
Annex E (informative) Example of a test table	35
Bibliography	36

Foreword

ISO (the International Organization for Standardization) is a worldwide federation of national standards bodies (ISO member bodies). The work of preparing International Standards is normally carried out through ISO technical committees. Each member body interested in a subject for which a technical committee has been established has the right to be represented on that committee. International organizations, governmental and non-governmental, in liaison with ISO, also take part in the work. ISO collaborates closely with the International Electrotechnical Commission (IEC) on all matters of electrotechnical standardization.

International Standards are drafted in accordance with the rules given in the ISO/IEC Directives, Part 2.

The main task of technical committees is to prepare International Standards. Draft International Standards adopted by the technical committees are circulated to the member bodies for voting. Publication as an International Standard requires approval by at least 75 % of the member bodies casting a vote.

Attention is drawn to the possibility that some of the elements of this document may be the subject of patent rights. ISO shall not be held responsible for identifying any or all such patent rights.

ISO 11204 was prepared by Technical Committee ISO/TC 43, *Acoustics*, Subcommittee SC 1, *Noise*.

This second edition cancels and replaces the first edition (ISO 11204:1995), which has been technically revised. It also incorporates the Technical Corrigendum ISO 11204:1995/Cor.1:1997.

Introduction

This International Standard specifies a method for determining the emission sound pressure levels at a work station and at other well defined positions, in the vicinity of a machine or piece of equipment, *in situ*. It is one of a series (ISO 11200^[15] to ISO 11205^[19]) which specifies various methods for determining the emission sound pressure level at a work station and at other specified positions of a machine or equipment. ISO 11200^[15] gives guidance on the choice of the method to be used to determine the emission sound pressure levels of machinery and equipment.

The method specified in this International Standard differs from those of ISO 11201^[16] in determining and applying a local environmental correction. It differs from ISO 11202^[17] by using an exact measurement of sound pressure levels on a reference measurement surface to determine the directivity of the sound radiation of the machine under test. The acoustical properties of the room have to be determined to qualify the test environment and to determine a correction for local environmental influences applied to the measured sound pressure levels. With the method specified in this International Standard, results of accuracy grade 2 (engineering grade) or accuracy grade 3 (survey grade) are obtained.

The method specified in this International Standard is generally applicable *in situ*. No assumptions about the directivity of the radiation or the source location are necessary, because this directivity is determined measuring the sound pressure levels on an enveloping surface. The grade of accuracy of the procedure with existing conditions can be qualified as engineering or survey.

In general, the emission sound pressure levels are less than or equal to those that occur when the machine is operating in its normal surroundings. This is because the sound pressure levels are determined by excluding the effects of background noise, as well as the effects of reflections other than those from the reflecting plane on which the machine under test is placed. For determination or calculation of the sound pressure level at the operator's position with the machine operating in a room, both sound power level and sound pressure level are required (as well as information on the room properties or reflections and noise from other sound sources or machines). A method of calculating the sound pressure levels in the vicinity of a machine operating alone in a workroom is given in ISO/TR 11690-3^[20]. Commonly observed differences are 1 dB to 5 dB, but in extreme cases the difference may be even greater.

Acoustics — Noise emitted by machinery and equipment — Determination of emission sound pressure levels at a work station and at other specified positions applying accurate environmental corrections

1 Scope

1.1 General

This International Standard specifies a method for determining the emission sound pressure levels of machinery or equipment, at a work station and at other specified positions nearby, in any environment which meets certain qualification requirements. A work station is occupied by an operator and may be located in open space, in the room where the source under test operates, in a cab fixed to the source under test, or in an enclosure remote from the source under test. One or more specified positions may be located in the vicinity of a work station, or in the vicinity of an attended or unattended machine. Such positions are sometimes referred to as bystander positions.

Emission sound pressure levels are determined as A-weighted levels. Additionally, levels in frequency bands and C-weighted peak emission sound pressure levels can be determined in accordance with this International Standard, if required.

NOTE 1 The contents of the series ISO 11200^[15] to ISO 11205^[19] are summarized in ISO 11200^[15].

A method is given for determining a local environmental correction (subject to a specified limiting maximum value) to be applied to the measured sound pressure levels to exclude the effects of reflections from reflecting surfaces other than the plane on which the source under test is placed. This correction is based upon the mean sound pressure level on a measurement surface, the sound pressure level measured at a specified position, and either an environmental correction or the equivalent absorption area of the test room.

With the method specified in this International Standard, results of accuracy grade 2 (engineering grade) or accuracy grade 3 (survey grade) are obtained. Corrections are applied for background noise and, as described above, for the acoustic environment. Instructions are given for the mounting and operation of the source under test and for the choice of microphone positions for the work station and for other specified positions. One purpose of the measurements is to permit comparison of the performance of different units of a given family of machines, under defined environmental conditions and standardized mounting and operating conditions.

NOTE 2 The data obtained can also be used for the declaration and verification of emission sound pressure levels as specified in ISO 4871^[9].

1.2 Types of noise and noise sources

The method specified in this International Standard is suitable for all types of noise (steady, non-steady, fluctuating, isolated bursts of sound energy, etc.) defined in ISO 12001.

The method specified in this International Standard is applicable to all types and sizes of noise sources.

NOTE Throughout this International Standard the words “machine” and “source under test” are used to represent either a machine or a piece of equipment.

1.3 Test environment

The type of test environment influences the accuracy of the determination of emission sound pressure levels. This International Standard is applicable to an indoor or outdoor environment with one or more reflecting planes present, meeting specified requirements. These requirements on the room are less strict than those of ISO 11201^[16], in particular regarding the acoustical quality of the environment.

1.4 Work station and other specified positions

This International Standard is applicable to work stations and other specified positions where emission sound pressure levels are to be determined.

Appropriate positions where measurements may be made include the following:

- a) work station located in the vicinity of the source under test; this is the case for many industrial machines and domestic appliances;
- b) work station within a cab which is an integral part of the source under test; this is the case for many industrial trucks and earth-moving machines;
- c) work station within a partial or total enclosure (or behind a screen) supplied by the manufacturer as an integral part of the source under test;
- d) work station partially or totally enclosed by the source under test — this situation may be encountered with some large industrial machines;
- e) bystander positions occupied by individuals not responsible for the operation of the source under test, but who may be in its immediate vicinity, either occasionally or continuously;
- f) other specified positions, not necessarily work stations or bystander positions.

The work station may also lie on a specified path along which an operator moves (see 9.4).

2 Normative references

The following referenced documents are indispensable for the application of this document. For dated references, only the edition cited applies. For undated references, the latest edition of the referenced document (including any amendments) applies.

ISO 3744, *Acoustics — Determination of sound power levels of noise sources using sound pressure — Engineering method in an essentially free field over a reflecting plane*

ISO 3746, *Acoustics — Determination of sound power levels of noise sources using sound pressure — Survey method using an enveloping measurement surface over a reflecting plane*

ISO 5725 (all parts), *Accuracy (trueness and precision) of measurement methods and results*

ISO 12001, *Acoustics — Noise emitted by machinery and equipment — Rules for the drafting and presentation of a noise test code*

IEC 60942:2003, *Electroacoustics — Sound calibrators*

IEC 61260:1995, *Electroacoustics — Octave-band and fractional-octave-band filters* (amended by IEC 61260/Amd.1:2001)

IEC 61672-1:2002, *Electroacoustics — Sound level meters — Part 1: Specifications*

ISO/IEC Guide 98-3:2008, *Uncertainty of measurement — Part 3: Guide to the expression of uncertainty in measurement (GUM:1995)*

3 Terms and definitions

For the purposes of this document, the following terms and definitions apply. More detailed definitions can be found in noise test codes for specific types of machines.

3.1 emission

(acoustics) airborne sound radiated by a well-defined noise source (e.g. the machine under test)

NOTE Noise emission descriptors can be incorporated into a product label and/or product specification. The basic noise emission descriptors are the sound power level of the source itself and the emission sound pressure levels at a work station and/or at other specified positions (if any) in the vicinity of the source.

3.2 emission sound pressure

p
sound pressure, at a work station or another specified position near a noise source, when the source is in operation under specified operating and mounting conditions on a reflecting plane surface, excluding the effects of background noise as well as the effects of reflections other than those from the plane or planes permitted for the purpose of the test

NOTE Emission sound pressure is expressed in pascals.

3.3 emission sound pressure level

L_p
ten times the logarithm to the base 10 of the ratio of the square of the emission sound pressure, p , to the square of a reference value, p_0 , expressed in decibels

$$L_p = 10 \lg \frac{p^2}{p_0^2} \text{ dB} \quad (1)$$

where the reference value, p_0 , is 20 μPa

NOTE The emission sound pressure level is determined at a work station or another specified position in accordance with either a noise test code for a specific family of machines or, if no noise test code exists, one of the standards of the series ISO 11200^[15] to ISO 11205^[19].

3.4 time-averaged emission sound pressure level

$L_{p,T}$
ten times the logarithm to the base 10 of the ratio of the time average of the square of the emission sound pressure, p , during a stated time interval of duration, T (starting at t_1 and ending at t_2), to the square of a reference value, p_0 , expressed in decibels

$$L_{p,T} = 10 \lg \left[\frac{\frac{1}{T} \int_{t_1}^{t_2} p^2(t) dt}{p_0^2} \right] \text{ dB} \quad (2)$$

where the reference value, p_0 , is 20 μPa

NOTE 1 For simplicity of notation, the subscript T is omitted throughout the following text.

NOTE 2 If specific frequency and time weightings as specified in IEC 61672-1 and/or specific frequency bands are applied, this is indicated by appropriate subscripts; e.g. L_{pA} denotes the A-weighted emission sound pressure level.

NOTE 3 Equation (2) is equivalent to that for the environmental noise descriptor “equivalent continuous sound pressure level” (ISO 1996-1^[1]). However, the emission quantity defined above is used to characterize the noise emitted by a source under test and assumes that standardized measurement and operating conditions as well as a controlled acoustical environment are used for the measurements.

3.5 peak emission sound pressure

p_{peak}
greatest absolute emission sound pressure during a stated time interval

NOTE 1 Peak sound pressure is expressed in pascals.

NOTE 2 A peak sound pressure may arise from a positive or negative sound pressure.

3.6 peak emission sound pressure level

$L_{p,\text{peak}}$
ten times the logarithm to the base 10 of the ratio of the square of the peak emission sound pressure, p_{peak} , to the square of a reference value, p_0 , expressed in decibels

$$L_{p,\text{peak}} = 10 \lg \frac{p_{\text{peak}}^2}{p_0^2} \text{ dB} \quad (3)$$

where the reference value, p_0 , is 20 μPa

NOTE The peak emission sound pressure level is usually C-weighted and denoted by $L_{pC,\text{peak}}$.

3.7 single event emission sound pressure level

L_E
ten times the logarithm to the base 10 of the ratio of the integral of the square of the emission sound pressure, p , of an isolated single sound event (burst of sound or transient sound) of specified duration T (or specified measurement time interval $T = t_2 - t_1$ covering the single event) to the square of a reference value, p_0 , normalized to reference time interval $T_0 = 1$ s, expressed in decibels

$$L_E = 10 \lg \left[\frac{1}{T_0} \int_{t_1}^{t_2} \frac{p^2(t)}{p_0^2} dt \right] \text{ dB} \quad (4)$$
$$= L_{p,T} + 10 \lg \frac{T}{T_0} \text{ dB}$$

NOTE Equation (4) is equivalent to that for the environmental noise descriptor “sound exposure level” (ISO/TR 25417:2007^[21], 2.7). However, the emission quantity defined above is used to characterize the noise emitted by a source under test and assumes that standardized measurement, mounting, and operating conditions as well as a controlled acoustical environment are used for the measurements.

3.8 acoustic free field over a reflecting plane

sound field in a homogeneous, isotropic medium in the half space above an infinite reflecting plane, in the absence of any other obstacles

3.9 frequency range of interest

for general purposes, the frequency range of octave bands with nominal mid-band frequencies from 125 Hz to 8 000 Hz or the one-third octave bands with nominal mid-band frequencies from 100 Hz to 10 000 Hz

NOTE 1 Adapted from ISO 6926:1999^[10], 3.10.

NOTE 2 For special purposes, the frequency range may be extended or reduced, provided that the test environment and instrument specifications are satisfactory for use over the modified frequency range. Changes to the frequency range of interest should be made clear in the test report. For sources which emit sound at predominantly high or low frequencies, the frequency range of interest should be extended to include these frequencies.

3.10 work station operator's position

position in the vicinity of the machine under test which is intended for the operator

3.11 operator

individual whose work station is in the vicinity of a machine and who is performing a work task associated with that machine

3.12 specified position

position defined in relation to a machine, including, but not limited to, an operator's position

NOTE 1 The position can be a single, fixed point, or a combination of points along a path or on a surface located at a specified distance from the machine, as described in the relevant noise test code, if one exists.

NOTE 2 Positions located in the vicinity of a work station, or in the vicinity of an unattended machine, may be identified as "bystander positions".

NOTE 3 Throughout the text of this International Standard, the word "work station" applies to possible specified positions listed in 1.4.

3.13 operational period

interval of time during which a specified process is accomplished by the source under test

EXAMPLE For a dishwasher, when washing or rinsing or drying.

3.14 operational cycle

specific sequence of operational periods occurring while the source under test performs a complete work cycle, where each operational period is associated with a specific process that may occur only once, or may be repeated, during the operational cycle

EXAMPLE For a dishwasher, when washing and rinsing and drying.

3.15 measurement time interval

portion or a multiple of an operational period or operational cycle of the source under test, for which the time-averaged emission sound pressure level is determined or over which the maximum emission sound pressure level is sought

3.16 time history

continuous recording of the emission sound pressure level, as a function of time, which is obtained during one or more operational periods of an operational cycle

3.17

background noise

noise from all sources other than the source under test

NOTE Background noise can include contributions from airborne sound, structure-borne vibration, and electrical noise in instrumentation.

3.18

background noise correction

K_1

correction applied to the measured sound pressure levels to account for the influence of background noise

NOTE 1 Background noise correction is expressed in decibels.

NOTE 2 Background noise correction is frequency dependent. In the case of A-weighting, the correction, K_{1A} , is determined from A-weighted measured values.

3.19

reference box

hypothetical rectangular parallelepiped terminating on the reflecting plane(s) on which the noise source under test is located, that just encloses the source including all the significant sound-radiating components and any test table on which the source may be mounted

3.20

reference measurement surface

S_M

hypothetical surface defined by a rectangular parallelepiped enveloping the source under test, terminating on the reflecting plane(s) on which the source is located, and having sides parallel to those of the reference box with each side spaced at equal distance from the corresponding side of the reference box

NOTE 1 The "equal distance" is preferably of 1 m.

NOTE 2 The work station does not have to be located on the reference measurement surface.

3.21

environmental correction

K_2

term to account for the influence of reflected sound on the mean sound pressure level on the reference measurement surface, expressed in decibels

NOTE 1 K_2 is frequency dependent and can be determined in accordance with ISO 3744 or ISO 3746. In the case of A-weighting, it is denoted K_{2A} .

NOTE 2 For the purposes of this International Standard, the environmental correction K_2 is only used as an indicator to qualify the environment and is determined for the reference measurement surface.

3.22

work station directivity index

$D_{I,op}$

measure of the extent to which a source under test radiates sound in the direction of the work station (operator's position), relative to the mean sound radiation over the reference measurement surface, expressed in decibels

$$D_{I,op} = L_p - \overline{L_p} \quad (5)$$

where

L_p is the emission sound pressure level;

$\overline{L_p}$ is the surface sound pressure level (in accordance with ISO 3744) on the reference measurement surface

NOTE These levels are determined in an essentially free field over a reflecting plane and have been corrected for background noise and for environmental influences, if relevant.

3.23

apparent work station directivity index

$D_{I,op}^*$

$$D_{I,op}^* = L_p^* - \overline{L_p^*} \quad (6)$$

where

L_p^* is the sound pressure level measured at the work station, corrected for background noise, but not for the influence of the environment;

$\overline{L_p^*}$ is the sound pressure level averaged over the reference measurement surface, corrected for background noise, but not for the influence of the environment

3.24

local environmental correction

K_3

correction applied to the measured sound pressure levels at the work station to account for the influence of reflected sound, expressed in decibels

NOTE 1 In the case of A-weighting, it is denoted K_{3A} .

NOTE 2 The local environmental correction is frequency dependent.

4 Instrumentation

4.1 General

The instrumentation system, including the microphones, cables and windscreen, if used, shall meet the requirements of IEC 61672-1:2002, class 1, and the filters, if relevant, shall meet the requirements of IEC 61260:1995, class 1.

A class 2 sound level meter can be used but the measurement result is then automatically of accuracy grade 3.

4.2 Calibration

Before and after each series of measurements, a sound calibrator meeting the requirements of IEC 60942:2003, class 1, shall be applied to each microphone to verify the calibration of the entire measuring system at one or more frequencies over the frequency range of interest. Without any further adjustment, the difference between the readings at each end of the series of measurements shall be less than or equal to 0,5 dB. If the difference exceeds 0,5 dB, the results of the series of measurements shall be discarded.

The sound calibrator shall be calibrated, and the compliance of the instrumentation system with the requirements of IEC 61672-1 shall be verified at intervals in a laboratory making calibrations traceable to appropriate standards.

Unless national regulations dictate otherwise, the sound calibrator should be calibrated annually, and the compliance of the instrumentation system with the requirements of IEC 61672-1 should be verified at intervals not exceeding 2 years.

5 Test environment

5.1 General

Any environment which meets the qualification requirements of 5.2, 5.4, 5.6 and Annex A is suitable for measurements in accordance with this International Standard.

5.2 Criterion for the adequacy of the test environment

For this International Standard, the environmental correction, K_{2A} , determined in accordance with ISO 3744 or ISO 3746, shall not exceed 7 dB. Further requirements on the test environment influencing the local environmental correction, K_{3A} (see 5.6), are specified in Annex A.

If $K_{2A} > 7$ dB, either the acoustical quality of the environment requires improvement or ISO 11205^[19] can be used.

5.3 Enclosed work station positions

When the operator is located in an enclosed cab or in an enclosure remote from the source under test, the cab or enclosure is regarded as an integral part of the source under test and, consequently, sound reflections inside the cab or enclosure are considered contributions to the emission sound pressure level.

During noise emission measurements, doors and windows of the cabin or enclosure shall be open or closed as specified in the relevant noise test code, if one exists.

The local environmental correction, K_3 , is determined as described in A.2 and A.3 using the apparent work station directivity index, $D_{1\text{op}}^*$. With the work station position in an enclosure this apparent work station directivity index, $D_{1\text{op}}^*$, is determined based on Equation (6), but with L_p^* measured at a position outside the enclosure at a comparable distance (distance from the source under test to the centre of the cabin) from the source under test. This is necessary in all cases when the noise inside the cabin is due to airborne sound transmission into the cabin enclosure, i.e. the noise level at the ears of the operator in the cabin is due to the sound field outside the cabin. If levels inside the cabin are strongly dependent on the microphone position, at least four measurement points shall be used to sample the sound field in the relevant part of the cabin. These positions shall be reported according to 12.6.

5.4 Criteria for background noise

5.4.1 General

At the microphone position(s), the background noise (including wind noise at the microphone) measured as A-weighted sound pressure level or (if results in frequency bands are required) in each of the frequency bands of interest shall be at least 6 dB for accuracy grade 2 (engineering) or 3 dB for accuracy grade 3 (survey) below the uncorrected level of the source under test measured in the presence of this background noise.

If the above 6 dB criterion or the 3 dB criterion is not satisfied, data may still be taken and reported, but the accuracy of the results may be reduced. In this case, the report shall clearly state that the background noise requirements of this International Standard have not been met, and (if frequency band data are reported) shall identify the particular frequency bands that do not meet the criteria. Furthermore, the report shall not state or imply that the measurements have been made in "full conformity" with this International Standard.

For measurements in frequency bands, further criteria for background noise are given in Annex B.

5.4.2 Corrections for background noise

The measured sound pressure levels (A-weighted or in frequency bands) shall be subject to a correction for the presence of background noise, K_1 , calculated according to Equation (7):

$$K_1 = -10 \lg(1 - 10^{-0,1 \Delta L}) \text{ dB} \quad (7)$$

where ΔL is the difference between the sound pressure levels measured (A-weighted or in frequency bands), at the work station, with the source under test in operation and turned off, respectively.

For the purposes of this International Standard, if $\Delta L > 15$ dB, assume $K_1 = 0$.

For accuracy grade 2, if $\Delta L < 6$ dB for one or more octave or one-third-octave frequency bands, the accuracy of the result(s) may be reduced and the value of K_1 to be applied in the case of these bands is 1,3 dB, which is the value for $\Delta L = 6$ dB.

For accuracy grade 3, if $\Delta L < 3$ dB for one or more octave or one-third-octave frequency bands, the accuracy of the result(s) may be reduced and the value of K_1 to be applied is 3 dB, which is the value for $\Delta L = 3$ dB.

In both cases, it shall be clearly stated in the text of the report, as well as in graphs or tables of results, that the data in such bands represent upper bounds to the emission sound pressure level of the noise source under test for the relevant grade of accuracy. If the background noise requirements for accuracy grade 2 are not met, it is still possible that the requirements for accuracy grade 3 are fulfilled. In this case, the final result can be reported claiming for accuracy grade 3 in accordance with this International Standard (if all other requirements are also fulfilled).

Determine K_1 for each work station.

5.5 Ambient conditions during measurements

Ambient conditions may have an adverse effect on the microphone used for the measurements. Such conditions (e.g. strong electric or magnetic fields, wind, high or low temperatures, or impingement of air discharge from the source under test) shall be avoided by proper selection or positioning of the microphone.

At altitudes less than or equal to 500 m above sea level and in temperature range from $-20\text{ }^{\circ}\text{C}$ to $40\text{ }^{\circ}\text{C}$ no normalization to reference meteorological conditions is required. At altitudes greater than 500 m (accuracy grade 2) or greater than 800 m (accuracy grade 3) above sea level or temperatures outside the above range the measured sound pressure level, L_p , in decibels, shall be normalized to the reference meteorological conditions

$$p_{\text{amb},0} = 1,013\ 25 \times 10^5 \text{ Pa}$$

$$\theta_0 = 296 \text{ K}$$

by using Equation (8) to obtain the emission sound pressure level for the reference meteorological conditions, $L_{p,0}$, in decibels

$$L_{p,0} = L_p - 20 \lg \frac{p_{\text{amb}}}{p_{\text{amb},0}} \text{ dB} + 20 \lg \frac{\theta}{\theta_0} \text{ dB} \quad (8)$$

where

p_{amb} is the ambient pressure, in pascals, at the time and place of the test;

θ is the air temperature, in kelvins, at the time and place of the test.

5.6 Local environmental correction and grade of accuracy

Annex A describes a procedure for determining the magnitude of the local environmental correction, K_3 , to account for the influence of reflected sound on the emission sound pressure level at the work station(s).

The method given in Annex A requires data for a number of measurement positions around the source under test, as well as information about the acoustical properties of the test room. Measurements are only in full accordance with this International Standard if K_{3A} does not exceed 7 dB. For results of accuracy grade 2, K_{3A} shall be less than or equal to 4 dB; for results of accuracy grade 3, K_{3A} shall be less than or equal to 7 dB.

NOTE If the limit value of 7 dB is exceeded, the accuracy of the result is reduced. The result may, however, be reported and may be useful for determining an upper boundary for the emission sound pressure level at the work station.

6 Measured quantities

The basic quantities to be measured at each work station over the specified operational periods or operational cycle of the source under test are:

- the A-weighted sound pressure level, L'_{pA} (the prime indicates measured values);
- the C-weighted peak sound pressure level, $L_{pC, \text{peak}}$, if required.

Sound pressure levels using other frequency weightings or in octave or one-third-octave frequency bands, as well as other entities relating to the time-history of the noise emission (impulsiveness, sound pressure level as a function of time, etc.) may also be measured, as required, e.g. for the design of low-noise machines.

7 Quantities to be determined

The quantity to be determined is the A-weighted emission sound pressure level. Additionally, emission sound pressure levels in frequency bands may be determined.

In order to obtain emission sound pressure levels at the work station(s), both background noise corrections, K_1 , and local environmental corrections, K_3 , shall be applied to measured sound pressure levels, except peak sound pressure levels, $L_{pC, peak}$, for which no corrections are permitted.

Corrections K_1 and K_3 to be considered are those relevant to the frequency weighting or frequency bands for which emission sound pressure levels have been determined. For frequency bands and A-weighting, respectively:

$$L_p = L'_p - K_1 - K_3$$

$$L_{pA} = L'_{pA} - K_{1A} - K_{3A} \quad (9)$$

where the prime indicates measured values; no prime indicates emission values.

If a work station (within or outside an enclosure) is located within the contour of the machine, no local environmental correction is permitted.

If the source under test produces isolated single event sounds, the single event emission sound pressure level at the work station, L_E (see 3.7), should be determined with a background noise correction and local environmental correction applied to the measured values.

8 Mounting and operation of source under test

8.1 General

The manner in which the source under test is mounted and operated may have a significant influence on the emission sound pressure levels at the work station(s). This clause specifies conditions that are intended to minimize variations in the noise emission due to the mounting and operating conditions of the source under test. Relevant instructions of a noise test code, if one exists, shall be followed. The same mounting and operating conditions of the source under test shall be used for the determination of emission sound pressure levels and sound power levels. The noise test code may make an exception to this requirement on identical mounting conditions for machines that are used on tables. Such machines may be mounted on the floor during sound power determinations and mounted on a table during emission sound pressure level tests. The relevant noise test code, if one exists, describes the mounting and operating conditions in detail.

Particularly for large machines, it is necessary to make a decision as to which components, sub-assemblies, auxiliary equipment, power sources, etc., belong to the source under test.

For sources for which the noise level depends on ambient temperature (e.g. those containing speed-controlled cooling fans), the ambient temperature in the test environment in the immediate vicinity of the source under test shall be maintained at $23\text{ °C} \pm 2\text{ °C}$.

8.2 Location of source

The source under test shall be mounted with respect to the reflecting plane in one or more locations as if it were being mounted for normal usage. If not typically mounted against a wall, the source under test shall be remote from any wall, ceiling or other reflecting object.

Typical mounting conditions for some machines involve two or more reflecting surfaces (e.g. an appliance installed against a wall) or free space (e.g. a hoist) or an opening in an otherwise reflecting plane (so that radiation may occur on both sides of the vertical plane). Detailed information on mounting conditions should be based on the general requirements of this International Standard and on the relevant noise test code, if one exists.

8.3 Mounting of source

8.3.1 General

In many cases, the noise emission at the work station(s) of the source under test depends upon the support or mounting conditions of the source. Whenever a typical mounting condition exists for a source, that condition shall be used or simulated, if practicable.

If a typical mounting condition does not exist or cannot be utilized for the test, care shall be taken to avoid changes in the sound emission of the source under test caused by the mounting system used for the test. Steps shall be taken to reduce any sound radiation from the structure on which the source is mounted.

Many small machines, although themselves poor radiators of low-frequency sound, may, as a result of the method of mounting, radiate more low-frequency sound when their vibrational energy is transmitted to surfaces large enough to be efficient radiators. Resilient mounting shall be interposed, if possible, between the source under test and the supporting surfaces so that the transmission of vibration to the support and the reaction of the source are both minimized. In this case, the mounting base should be rigid (i.e. have a sufficiently high mechanical impedance) to prevent it from vibrating excessively and radiating sound. However, resilient mounts shall be used only if the source under test is resiliently mounted in typical field installations.

NOTE Coupling conditions (e.g. between prime movers and driven machines) can exert a considerable influence on the sound radiation of the source under test.

8.3.2 Hand-held machines

Such machines shall be suspended or guided by hand, so that no structure-borne sound is transmitted via any attachment that does not belong to the source under test. If the source under test requires a support for its operation, the support structure shall be small, considered to be a part of the source under test, and as described in the relevant noise test code, if one exists.

Power tools tested in the loaded condition, e.g. cutting material, in the manner typical of use, with materials and mounting conditions typical for that power tool may cause vibrations and noise emissions from the work piece and this may be typical of power tool usage.

8.3.3 Base-mounted and wall-mounted machines

Such machines shall be placed on a reflecting (acoustically hard) plane (floor or wall). Base-mounted machines intended exclusively for mounting in front of a wall shall be installed on an acoustically hard surface in front of an acoustically hard wall. Table-top machines shall be placed on a table or stand as required for operation in accordance with the relevant noise test code, if one exists. The table or stand shall be at least 1,5 m from any absorptive surface of the test room. Such machines shall be placed at the centre of the top of the standard test table. A suitable design for a test table is shown in Annex E.

8.4 Auxiliary equipment

Care shall be taken to ensure that any electrical conduits, piping or air ducts connected to the source under test do not radiate significant amounts of sound energy into the test environment.

If practicable, all auxiliary equipment necessary for the operation of the source under test that is not a part of it (see 8.1) shall be located outside the test environment. If this is impracticable, the auxiliary equipment shall be included in the test configuration and its operating conditions shall be recorded in the test report.

8.5 Operation of source during test

The emission sound pressure level produced by a source can be affected by the load applied, the running speed, and the conditions under which it is operating. The source shall be tested, wherever possible, under conditions that are reproducible and representative of the noisiest operation in typical usage. The specifications given in the relevant noise test code, if one exists, shall be followed, but in the absence of a noise test code one or more of the following modes of operation shall be selected for the test:

- a) source under specified load and conditions;
- b) source under full load (if different from above);
- c) source under no load (idling);
- d) source at maximum operating speed under defined conditions;
- e) source operating under conditions corresponding to maximum sound generation representative of normal use;
- f) source with simulated loading, under defined conditions;
- g) source undergoing a characteristic work cycle under defined conditions.

The source shall be stabilized in the desired operating condition, with any power source or transmission system running at a stable temperature, prior to the start of measurements for emission sound pressure level determination. The load, speed, and operating conditions shall be either held constant during the test, or varied through a defined cycle in a controlled manner.

If the emission sound pressure level depends on secondary operating parameters, e.g. the type of material being processed or the design of cutting tool, those parameters shall be selected, as far as is practicable, that give rise to the smallest variations and that are typical of normal use. If simulated loading conditions are used, they shall be chosen such that the emission sound pressure level of the source under test is representative of normal use.

9 Microphone positions

9.1 General

The measurement positions shall be chosen from the alternatives specified in 9.2, 9.3, 9.4 and 9.5.

The microphone shall be oriented in such a way that the angle of incidence of the sound coincides with the reference direction of the microphone as specified by the manufacturer to meet the requirements of IEC 61672-1.

Whenever practical, the emission sound pressure level shall be measured with the source under test unattended and with the microphone reference direction oriented towards the dominant sound source.

Generally, for free-field response microphones (calibrated for "normal incidence" to the microphone diaphragm), the axis of the microphone-preamplifier body should be oriented towards the dominant sound source. For diffuse-field response microphones, the axis of the microphone-preamplifier body should be oriented at a right angle with respect to the direction towards the dominant sound source.

The operator(s), if present, shall not wear clothing with abnormal sound-absorptive properties, or any hat or scarf (other than a protective helmet required for safety reasons, or a helmet or frame used to support a microphone) which might influence the sound measurements.

If an operator is present, the microphone shall be located $0,20\text{ m} \pm 0,02\text{ m}$ to the side of the centre plane of the operator's head, on a line with the eyes, with its axis parallel to the operator's line of vision, and on that side where the higher value of the A-weighted sound pressure level, L'_{pA} , is observed.

If the measured sound pressure level is strongly position dependent, it is recommended that the space average be taken on a small measuring surface (e.g. 0,5 m × 0,5 m) parallel to the reference box and centred at the work station.

Unless otherwise required in the relevant noise test code, if one exists, the operator position(s) shall be as specified in 9.2 to 9.5.

9.2 Microphone position(s) for a seated operator

If an operator is not present, and if the seat is attached to the source under test, the microphone shall be located 0,80 m ± 0,05 m above the middle of the seat plane, unless a particular noise test code states otherwise.

If an operator is not present, and if the seat is not attached to the source under test, the microphone position(s) shall be as described in the relevant noise test code, if one exists. If there is no noise test code, the microphone position(s) shall be described in the test report.

If an operator is present, the adjustment of the seat shall allow the operator to reach the controls comfortably, and the requirements of 9.1 apply.

9.3 Microphone position(s) for a standing, stationary operator

If the operator is present, the requirements of 9.1 apply. If the measurements are made with the operator or bystander absent or if no other location is specified for a standing operator in the relevant noise test code, if one exists, the microphone location is defined relative to a reference point on the ground plane on which the operator normally stands. This reference point is the point on the floor directly below the centre of the operator's head. The microphone shall be located directly above the reference point at a specified height in the range 1,55 m ± 0,075 m. The specified height is usually to be found in the relevant noise test code, if one exists.

9.4 Microphone position(s) for an operator moving along a specified path

In those situations where an operator moves along a specified path in the vicinity of the source under test, a sufficient number of microphone positions or a moving microphone shall be used to determine the sound pressure level along the specified path. This shall be done either by using continuous integration along the length of the path, or by making a sufficient number of measurements at discrete positions and defined intervals of time, and then applying Equation (10).

The reference line shall be defined as a line on the floor directly below the centre of the operator's head for a typical specified path. If no other height is specified for a moving operator in the relevant noise test code, if one exists, the microphone positions shall be located directly above the reference line at a specified height in the range 1,55 m ± 0,075 m.

In the case of fixed microphone positions, these shall be evenly spaced along the specified path. The spacing of the microphone positions shall not exceed 2 m. The microphone positions or the path shall be those defined in the relevant noise test code, if one exists. If no noise test code exists, the microphone positions shall be recorded and reported. The energy average of the levels from the fixed microphone positions shall be recorded and reported as the emission sound pressure level of the source under test.

9.5 Microphone positions for bystanders and for unattended machines

If no operator's position can be identified, a hypothetical work station or one or more bystander positions shall be defined. Noise test codes usually specify a hypothetical work station or bystander position(s).

Unless otherwise stated in the relevant noise test code, if one exists, measurements shall be made at four or more microphone positions located 1 m away from each side of the reference box (see 3.19) at a height of $1,55 \text{ m} \pm 0,075 \text{ m}$ above the ground plane. The value of the highest emission sound pressure level shall be recorded and reported as the emission sound pressure level of the source under test. The position where this value is measured shall be recorded and reported.

Instead of using discrete positions, it may be satisfactory to use the surface sound pressure level calculated from the sound power level in accordance with ISO 11203^[18].

A noise test code may require that the energy average of the levels from the four or more positions is recorded and reported as the emission sound pressure level of the source under test.

10 Measurements

10.1 Measurement time interval

10.1.1 General

The measurement time interval shall be chosen in such a way that the emission sound pressure level and, if required, the time characteristics of sound emission at a work station can be determined for the specified operating conditions.

For machines with a specified operational cycle, it is usually necessary to extend the measurement time interval to an integral number of consecutive operational cycles.

The measurement time interval shall correspond only to the operational periods for which the emission sound pressure level and, if required, the time characteristics of sound emission are desired.

Values of the measurement time interval, possible sub-measurement time intervals and number of operational cycles contained in the measurement time interval are usually to be found in the relevant noise test code, if one exists. In any case, these values shall be identical to those defined for determining the sound power level of the source under test.

10.1.2 Steady noise

If the noise emission at a work station is steady for the specified operating conditions (see ISO 12001), the measurement time interval shall be at least 10 s.

10.1.3 Non-steady noise

If the noise emission at a work station is not steady for the specified operating conditions, the measurement time interval and operational periods of the source under test shall be carefully defined and reported in the test results. They are normally specified in the relevant noise test code, if one exists.

10.1.4 Measurements in frequency bands

If measurements are to be made in octave or one-third-octave frequency bands, the minimum period of observation shall be 30 s for the frequency bands centred on or below 160 Hz; for the frequency bands centred on or above 200 Hz the measurement time interval shall be at least 10 s. For non-steady noise, 10.1.3 also applies.

10.1.5 Summarization of sub-measurement time intervals

For a given source under test, the measurement time interval, T , may be composed of a number of sub-measurement time intervals, T_i , each of which corresponds to a specified operational period of the source under test. In this case, a single emission sound pressure level, L_p , is usually desired. It is obtained by energy averaging the individual averaged A-weighted emission sound pressure levels related to sub-time intervals according to Equation (10):

$$L_{pA} = 10 \lg \left[\frac{1}{T} \sum_{i=1}^N T_i 10^{0,1 L_{pA, T_i}} \right] \text{ dB} \quad (10)$$

where

T is the total measurement time interval,

$$T = \sum_{i=1}^N T_i$$

T_i is the i th sub-measurement time interval;

N is the total number of sub-measurement time intervals or operational periods;

L_{pA, T_i} is the A-weighted emission sound pressure level over a sub-measurement time interval, T_i .

10.2 Measurement procedure

10.2.1 General

Sound pressure level(s) shall be measured at the work station(s) of the source under test over a typical period of operation (see 10.1). Background noise corrections as well as local environmental corrections shall be applied [see Equation (9)]. The instrumentation used shall comply with the requirements of Clause 4.

10.2.2 Repetition of measurements

In order to reduce the uncertainty of the determination of emission sound pressure levels at the work station(s), it may be necessary, for a specific type of source, to repeat the measurement a number of times as specified in the relevant noise test code, if one exists. The value (e.g. average or maximum) to be used after repeated measurements shall be that defined in the relevant noise test code, if one exists. Repeating measurements involves the following procedure:

- a) the source under test is turned off and on again, if feasible;
- b) the microphone is moved away and set again at the work station;
- c) the measurement is carried out again in the same environment, with the same instrumentation over the same measurement time interval and for the same mounting and operating conditions.

10.2.3 Procedure for impulsive noise

If the sound emission is impulsive, particular care shall be taken when measuring the sound pressure level to ensure that the dynamic range of the instrumentation is sufficiently large, and that the sound level meter is equipped with an overload indicator.

For measurement of the time characteristics of impulsive sound emissions (e.g. peak values), in addition to the repetition procedure specified in 10.2.2, the measurement time interval shall include at least 10 impulsive events, unless otherwise specified in the relevant noise test code, if one exists.

The final value retained is usually the average, unless the peak value is measured. In this case, the highest of the peak values is retained. If a more precise procedure is specified in the relevant noise test code, that procedure shall be used.

If the source under test produces isolated single event sounds, the single event emission sound pressure level at the work station position (see 3.7), L_{E^*} , shall be determined.

11 Measurement uncertainty

11.1 Methodology

The uncertainty, $u(L_p)$, in decibels, associated with the emission sound pressure level determined in accordance with this International Standard is estimated by the total standard deviation, σ_{tot} , in decibels:

$$u(L_p) \approx \sigma_{\text{tot}} \quad (11)$$

This total standard deviation is obtained using the modelling approach described in ISO/IEC Guide 98-3. This requires a mathematical model, which in the case of lack of knowledge can be replaced by results from measurements, including results from round robin tests.

In this context, this standard deviation is expressed by the standard deviation of reproducibility of the method, σ_{R0} , in decibels, and the standard deviation, σ_{omc} , in decibels, describing the uncertainty due to the instability of the operating and mounting conditions of the source under test according to Equation (12):

$$\sigma_{\text{tot}} = \sqrt{\sigma_{R0}^2 + \sigma_{\text{omc}}^2} \quad (12)$$

Equation (12) shows that variations of operating and mounting conditions expressed by σ_{omc} should be taken into account before a measurement procedure with a certain grade of accuracy (characterized by σ_{R0}) is selected for a specific machine family (see 11.5 and C.3).

NOTE If different measurement procedures offered by the series ISO 11200^[15] to ISO 11205^[19] are used, systematic numerical deviations (biases) can additionally occur.

Derived from σ_{tot} , the expanded uncertainty, U , in decibels, shall be calculated from

$$U = k \sigma_{\text{tot}} \quad (13)$$

The expanded uncertainty depends on the degree of confidence that is desired. For a normal distribution of measured values, and for a confidence level of 95 %, the confidence interval is $[L_p - U]$ to $[L_p + U]$. This corresponds to a coverage factor of $k = 2$.

If the purpose of determining the emission sound pressure level is to compare the result with a limit value, it may be more appropriate to apply the coverage factor for a one-sided normal distribution. In that case, the coverage factor $k = 1,6$ corresponds to a level of confidence of 95 %.

11.2 Determination of σ_{omc}

The standard deviation, σ_{omc} [see Equation (C.1)], which quantifies the uncertainty associated with the instability of the operating and mounting conditions for the particular source under test, shall be taken into account when determining the measurement uncertainty. It can be determined separately from repeated measurements carried out on the same source at the same location by the same persons, using the same measuring instruments and the same measurement position(s). To determine σ_{omc} , the measured sound

pressure levels, L'_p , do not require any correction. For each of these repeated measurements, the mounting of the machine and its operating conditions are to be readjusted. The symbol σ_{omc} is modified to σ'_{omc} for the individual sound source under test. A noise test code may provide a value of σ_{omc} representative for the machine family concerned. This value should take into account all possible variations of operating and mounting conditions that are within the scope of the noise test code.

NOTE If the sound emission does not vary or varies only a little with time and the measuring procedure is defined properly, a value of 0,5 dB for σ_{omc} can be applicable. In cases for example of a large influence of the material flow in and out of the machine or where this flow may vary in an unforeseeable manner, a value of 2 dB can be appropriate. However, in extreme cases where for example process noise generated by the material processed varies strongly (stone breaking machines, metal cutting machines and presses operating under load) even a value of 4 dB can result.

11.3 Determination of σ_{R0}

11.3.1 General

Most conditions and situations allowed by this International Standard (different radiation characteristics of the source under test, different instrumentation, different realizations of the measurement procedure) are covered by σ_{R0} . An exception is the influence of the instability of the sound emission of the source under test, which is considered separately by σ_{omc} .

The values of σ_{R0} given in Table 1 reflect knowledge at the time of publication. They are typical upper bounds taking into consideration the great variety of machines and equipment being covered by this International Standard. Machinery-specific values may be derived from round robin tests (see 11.3.2) or by using the modelling approach (see 11.3.3). They should be given in noise test codes specific to machinery families (see 11.2 and Annex C).

11.3.2 Round robin test

The round robin test for determining σ_{R0} shall be carried out in accordance with ISO 5725, where the emission sound pressure level of the source under test is determined under reproducibility conditions, i.e. different persons carrying out measurements at different testing locations with different measuring instruments. Such a test provides the total standard deviation, σ'_{tot} , relevant to the individual sound source which has been used for the round robin test. Participating laboratories in round robin tests should cover all possible practical situations.

This total standard deviation, σ'_{tot} , in decibels, of all results obtained with a round robin test includes the standard deviation, σ'_{omc} , and allows σ'_{R0} to be determined by using

$$\sigma'_{R0} = \sqrt{\sigma'_{\text{tot}}^2 - \sigma'_{\text{omc}}^2} \quad (14)$$

If σ'_{R0} values obtained from many different pieces of machinery belonging to the same family deviate within a small range only, their mean value can be regarded as typical for the application of this International Standard to this particular family and used as σ_{R0} . Whenever available, such a value should be given in the noise test code specific to the machine family concerned (together with σ_{omc}) and used in particular for the purpose of declaring noise emission values.

If no round robin test has been carried out, existing knowledge about the noise emission from a particular family of machines may be used to estimate realistic values of σ_{R0} .

For certain applications, the work involved in the round robin test can be reduced by omitting measurements for different locations, e.g. if machines under test are usually installed under conditions with a small background noise correction, K_1 , and a small or similar local environmental correction, K_3 , or if the noise emission of a machine should be checked at the same location again. Results of such delimited tests should be denoted by $\sigma_{R0,DL}$, and this designation should also be used for tests on large machines which are not movable in space.

NOTE Values for $\sigma_{R0,DL}$ can be expected to be lower than those given in Table 1.

The determination of σ_{R0} using Equation (14) is imprecise if σ_{tot} is only slightly higher than σ_{omc} . In this case, Equation (14) provides a small value of σ_{R0} but with a low accuracy. To limit this inaccuracy, σ_{omc} should not exceed $\sigma_{\text{tot}}/\sqrt{2}$.

11.3.3 Modelling approach for σ_{R0}

Generally σ_{R0} , in decibels, is dependent upon several partial uncertainty components, $c_i u_i$, associated with the different measurement parameters such as uncertainties of instruments, environmental corrections, and microphone positions. If these contributions are assumed to be uncorrelated, σ_{R0} can be described by the modelling approach presented in ISO/IEC Guide 98-3, as follows:

$$\sigma_{R0} \approx \sqrt{(c_1 u_1)^2 + (c_2 u_2)^2 + \dots + (c_n u_n)^2} \quad (15)$$

In Equation (15), the uncertainty components due to the instability of the sound emission of the source are not included. These components are covered by σ_{omc} . Annex C discusses each component of the uncertainty, σ_{R0} , according to knowledge at the time of publication.

NOTE If the uncertainty components in the modelling approach are correlated, Equation (15) is not valid. Furthermore, the modelling approach requires detailed knowledge for determining the individual terms in Equation (15).

By contrast, the estimation of σ_{R0} based on a round robin test does not require assumptions about possible correlations between the individual terms of Equation (15). Round robin test-based estimation is, at the time of publication, more realistic than the evaluation of possible correlations between the single terms of Equation (15) and their interdependencies with all other relevant parameters using the modelling approach. However, round robin tests are not always possible and are often replaced by experience from earlier measurements.

11.4 Typical upper bound values of σ_{R0}

Table 1 shows typical upper bound values of the standard deviation, σ_{R0} , for accuracy grades 2 and 3 that may cover most of the applications of this International Standard. In special cases or if certain requirements of this International Standard are not met for a machine family or if it is anticipated that actual values of σ_{R0} for a given family of machines are smaller than those given in Table 1, a round robin test is recommended to obtain machine-specific values of σ_{R0} .

Table 1 — Typical upper bound values of the standard deviation of reproducibility of the method, σ_{R0} , for the A-weighted emission sound pressure levels determined in accordance with this International Standard

Grade of accuracy	Standard deviation of reproducibility, σ_{R0} dB
2	1,5
3	3

11.5 Total standard deviation, σ_{tot} , and expanded uncertainty, U

The total standard deviation and the expanded uncertainty shall be determined using Equation (12) and Equation (13) respectively.

EXAMPLE Accuracy grade 2; $\sigma_{\text{omc}} = 2,0$ dB; coverage factor, $k = 1,6$; measured $L_{pA} = 82$ dB. Machine-specific determinations of σ_{R0} have not been undertaken thus the value is taken from Table 1 ($\sigma_{R0} = 1,5$ dB). Using Equations (13) and (12) it follows that

$$U = 1,6\sqrt{1,5^2 + 2^2} \text{ dB} = 4 \text{ dB}$$

The best estimate of the sound power level does not exceed 86 dB with a probability of 95 % assuming normal distribution of the fluctuating quantities (see C.5 and C.6).

Additional examples of calculated values for σ_{tot} are given in C.3.

NOTE The expanded uncertainty as described in this International Standard does not include the standard deviation of production which is used in ISO 4871^[9] for the purpose of making a noise declaration for batches of machines.

12 Information to be recorded

12.1 General

The following information, when applicable, shall be compiled and recorded for all measurements made in accordance with this International Standard. Rounding to the first place of decimals of computed data values shall occur only after performing the final computational step before recording.

12.2 Source under test

Description of the source under test, including its

- a) type;
- b) technical data;
- c) dimensions;
- d) manufacturer;
- e) serial number;
- f) year of manufacture.

12.3 Test conditions

Description of the test conditions, including:

- a) precise quantitative description of operating conditions if not specified in a machine-specific noise test code, if one exists, and, if relevant, operational periods and cycle;
- b) mounting conditions;
- c) location of the source under test in the test environment;
- d) if the source under test has multiple sources of noise, a description of the sources in operation.

12.4 Acoustic environment

Description of the test environment:

- a) if indoors, description of physical treatment of wall, ceiling and floor; sketch showing the location of the source under test and room contents; acoustical qualification of room in accordance with 5.2; air temperature in degrees Celsius, ambient pressure in pascals, and relative humidity as a percentage;
- b) if outdoors, sketch showing the location of the source under test with respect to surrounding terrain, including
 - 1) physical description of test environment,
 - 2) air temperature in degrees Celsius, ambient pressure in pascals, and relative humidity as a percentage,
 - 3) wind speed, in metres per second.

12.5 Instrumentation

Description of the instrumentation:

- a) equipment used for measurements, including name, type, serial number and manufacturer;
- b) method used for verifying the calibration of the measuring system; the date, place and result of calibration;
- c) characteristics of windscreen (if any).

12.6 Location of work station(s)

A precise quantitative description shall be recorded of all positions where sound pressure levels have been measured.

12.7 Noise data

Description of the noise data:

- a) all measured sound pressure level data;
- b) A-weighted emission sound pressure level(s) at work station(s) and, if required, the same quantity with other frequency weightings and/or in frequency bands;
- c) if required, C-weighted peak emission sound pressure level(s) at work station(s) and/or levels in frequency bands and/or other time characteristics of noise emission at work station(s);
- d) expanded measurement uncertainty of the results, in decibels, together with the associated coverage factor and coverage probability;
- e) A-weighted background noise levels and background noise correction, K_{1A} , at each work station, plus, if required, background noise levels and correction, K_1 , in frequency bands;
- f) A-weighted environmental correction, K_{2A} ;
- g) A-weighted local environmental correction, K_{3A} , at each of the work station(s);
- h) place, date when the measurements were performed, and person responsible for the test;
- i) optional information such as the highest emission sound pressure level measured on a measurement path or the apparent work station directivity index or any other data.

13 Test report

Only those data recorded in accordance with 12.2, 12.3 a) and b), 12.6, 12.7 b), c), d) and g) shall be reported. If a standardized noise test code exists for the source under test, report the data in accordance with the specifications of the code.

The test report shall include at least the following information:

- a) whether the reported emission sound pressure levels at the work station(s) have been obtained in full conformity with the requirements of this International Standard (ISO 11204:2010);
- b) the date on which the emission sound pressure levels were measured;

- c) the name of the person responsible for the tests;
- d) the local environmental correction, K_{3A} ;
- e) an explicit statement of the grade of accuracy achieved [accuracy grade 2 (engineering) or accuracy grade 3 (survey)] and the total standard deviation — additional information may be given on the basis of Annex C;
- f) emission sound pressure levels, in decibels, at the work station(s) and the associated expanded measurement uncertainties, in decibels, resulting from the grade of accuracy, reported to the nearest first place of decimals.

Annex A (normative)

Environmental correction for a work station — Determination of the local environmental correction, K_3

A.1 General

A.1.1 According to this method, the local environmental correction, K_3 , is calculated from the following:

- a) the mean value of the sound pressure level (corrected for background noise, but not for the environmental influence) on the reference measurement surface, $\overline{L_p^*}$, given by Equation (A.1):

$$\overline{L_p^*} = 10 \lg \left(\frac{1}{N} \sum_{i=1}^N 10^{0,1L_{pi}^*} \right) \text{dB} \quad (\text{A.1})$$

where $\overline{L_p^*}$ is determined from a number of measured sound pressure levels, L_{pi}^* , at N positions around the source under test — it is recommended that the number and locations of the microphone positions be identical with the positions used when determining the sound power level by the enveloping surface method according to ISO 3744 or ISO 3746;

- b) the sound pressure level (corrected for background noise, but not for the environmental influence) at the work station, L_p^* — this work station does not have to be located on the measurement surface used to determine $\overline{L_p^*}$.

If an operator moves along a path, values of L_{pi}^* should be determined at positions equally spaced along the path. A single value of L_p^* should be calculated based on the energy-averaged value.

A.1.2 Depending upon the information available, K_3 may be determined either according to A.2 using an average environmental correction, K_2 (see 3.21), for the reference measurement surface or according to A.3 using the ratio A/S_M , where A is the equivalent absorption area of the test room. As the methods given in A.2 and A.3 are based on the same assumptions, they will in principle give the same magnitude of K_3 .

A.2 Determination of the local environmental correction, K_3 , based on the average environmental correction, K_2

The local environmental correction, K_3 , is specified as follows:

$$K_3 = \begin{cases} 7 \text{ dB} & \text{for } z \leq 0,2 \\ -10 \lg z \text{ dB} & \text{for } 0,2 < z \leq 1 \\ 0 \text{ dB} & \text{for } z > 1 \end{cases} \quad (\text{A.2})$$

where

$$z = 1 - (1 - 10^{-0,1 K_2}) \cdot 10^{-0,1 D_{I op}^*} \quad (A.3)$$

K_2 is the average environmental correction for the reference measurement surface for which $\overline{L_p^*}$ has been determined (see ISO 3744);

$D_{I op}^*$ is the apparent work station directivity index (see 3.23).

If the sound power level, L_W , is known, $\overline{L_p^*}$ can be obtained from

$$\overline{L_p^*} = L_W - L_{S_M} + K_2 \quad (A.4)$$

where

$$L_{S_M} = 10 \lg \frac{S_M}{S_0} \text{ dB}$$

S_M is the area of the reference measurement surface for which K_2 has been determined;

$S_0 = 1 \text{ m}^2$.

Figure A.1 gives a graphical representation of K_3 in function of K_2 and $D_{I op}^*$.

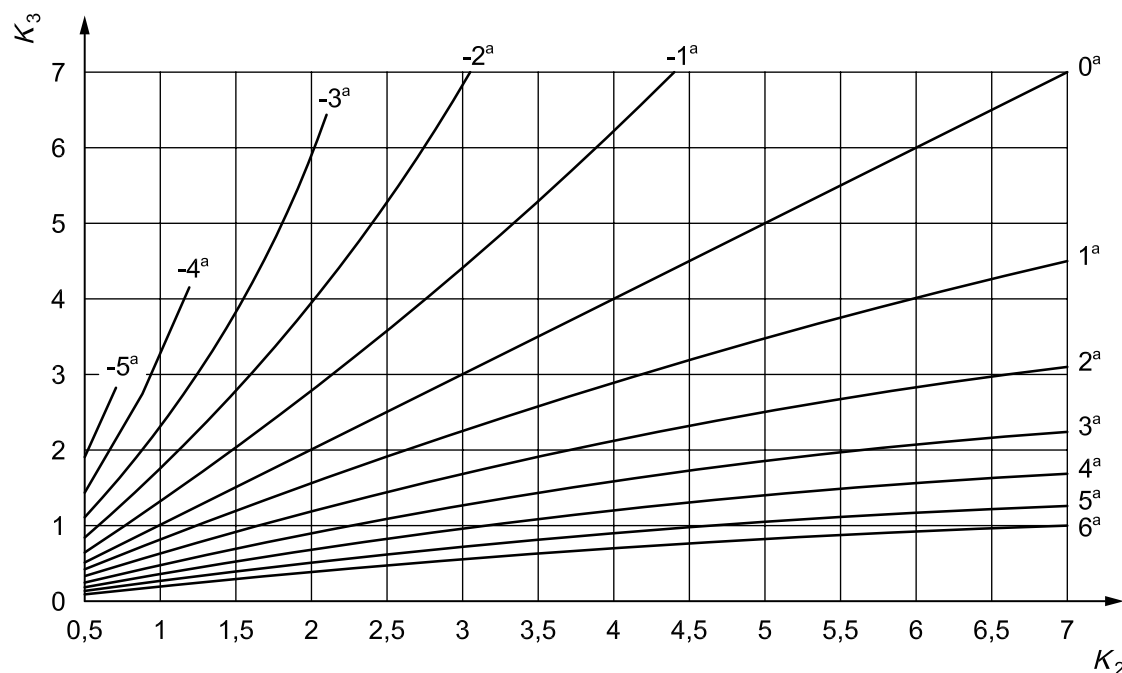

Key

- K_2 environmental correction, in decibels
- K_3 local environmental correction, in decibels
- ^a Value of $D_{I op}^*$, in decibels.

NOTE Due to the steepness of the possible extension of the curves in the upper left area of the diagram Equations (A.5) and (A.6) should be used in this range.

Figure A.1 — K_3 determined from K_2 and $D_{I op}^*$, all expressed in decibels, being a graphical representation of Equations (A.2) and (A.3)

A.3 Determination of the local environmental correction, K_3 , based on the equivalent sound absorption area, A , of the test room

The local environmental correction, K_3 , is specified as follows:

$$K_3 = \begin{cases} 7 \text{ dB} & \text{for } z \leq 0,2 \\ -10 \lg z \text{ dB} & \text{for } 0,2 < z \leq 1 \\ 0 \text{ dB} & \text{for } z > 1 \end{cases} \quad (\text{A.5})$$

where

$$z = 1 - \frac{1}{1 + A/(4S_M)} \cdot 10^{-0,1 D_{Iop}^*} \quad (\text{A.6})$$

S_M is the area of the reference measurement surface for which $\overline{L_p^*}$ has been determined;

A is the equivalent sound absorption area of the test room (see ISO 3744);

D_{Iop}^* is the apparent work station directivity index (see 3.23).

Instead of performing the above calculations, Figure A.2, a graphical representation of K_3 in function of A/S_M and D_{Iop}^* , may be used.

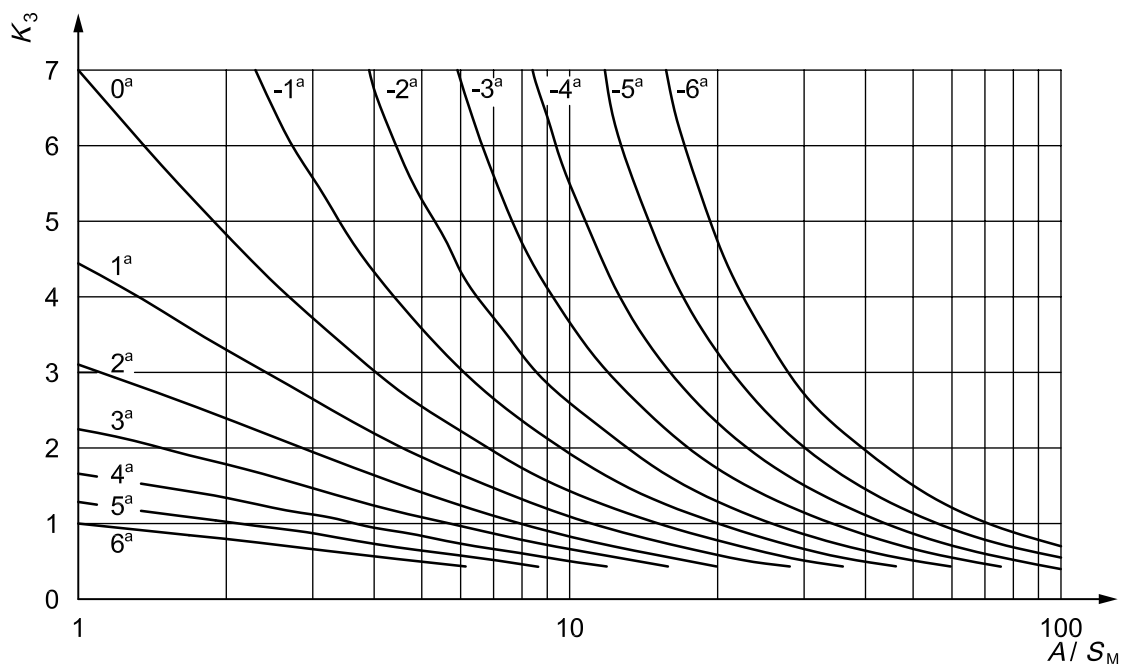

Key

- A sound absorption area
- K_3 local environmental correction, in decibels
- S_M reference measurement surface
- a Value of D_{Iop}^* , in decibels.

Figure A.2 — K_3 , in decibels, determined from A/S_M and D_{Iop}^* , being a graphical representation of Equations (A.5) and (A.6)

Annex B (normative)

Criteria for background noise for measurements in frequency bands

B.1 Absolute criteria for background noise

If it can be demonstrated that the background noise levels in the test room at the time of the measurements are less than or equal to those given in Table B.1 for all bands within the frequency range of interest, the measurements can be taken as having met the background noise requirements of this International Standard, even if the 6 dB requirement for accuracy grade 2, or 3 dB requirement for accuracy grade 3 (see 5.4.1), is not met for all bands. It can be assumed that the source emits little or no measurable noise in these frequency bands, and that the data reported represent upper bounds to the emission sound pressure level in these bands.

B.2 Relative criteria for frequency band measurements

The requirements of 5.4.1 may not be achievable in all frequency bands, even when the background noise levels in the test room are extremely low and well controlled. Therefore, any band within the frequency range of interest in which the A-weighted sound pressure level of the source under test is at least 15 dB (accuracy grade 2) or 10 dB (accuracy grade 3) below the highest A-weighted band sound pressure level may be excluded from the frequency range of interest for the purposes of determining compliance with the criterion for background noise of 5.4.1.

B.3 Relative criteria for A-weighted level determined from frequency band levels

If the A-weighted emission sound pressure level is to be determined from frequency band levels, the following steps shall be followed to determine whether this quantity meets the background noise criteria of this International Standard:

- a) the A-weighted emission sound pressure level is computed by analogy to the relevant procedures of ISO 3744 using the data from every frequency band within the frequency range of interest;
- b) the computation is repeated, but excluding those bands for which ΔL_p is less than 6 dB for accuracy grade 2 or less than 3 dB for accuracy grade 3.

If the difference between these two levels is less than 0,5 dB for accuracy grade 2 or less than 0,7 dB for accuracy grade 3, the A-weighted emission sound pressure level determined from the data for all bands shall be considered as conforming to the background noise criteria of this International Standard.

B.4 Failure to meet relevant criteria

If the background noise criteria (one of 5.4.1, B.1 or B.2, and additionally B.3 if the A-weighted level is determined from frequency bands) are not satisfied, the report shall clearly state that the background noise requirements of this International Standard have not been met, and shall identify the particular frequency bands that do not meet the criteria. Furthermore, the report shall not state or imply that the measurements have been made "in full conformity" with this International Standard.

Table B.1 — Maximum background noise levels in test room for absolute criteria

One-third-octave mid-band frequency	Maximum band sound pressure level
Hz	dB
50	44
63	38
80	32
100	27
125	22
160	16
200	13
250	11
315	9
400	8
500	7
630	7
800	7
1 000	7
1 250	7
1 600	7
2 000	7
2 500	8
3 150	8
4 000	8
5 000	8
6 300	8
8 000	12
10 000	14
12 500	11
16 000	46
20 000	46

Annex C (informative)

Guidance on the development of information on measurement uncertainty

C.1 General

The accepted format for the expression of uncertainties generally associated with methods of measurement is that given in ISO/IEC Guide 98-3. This format incorporates a budget of uncertainty components, in which various sources of uncertainty are identified and from which the combined total measurement uncertainty can be obtained.

To determine the noise emission of machines and equipment, it is advisable to split up its total uncertainty into two different groups of uncertainty components:

- a) those that are intrinsic to the measurement procedure;
- b) those that result from the instability of the sound emission of the machine.

Based on knowledge at the time of publication, this annex provides additional explanations and information by which ISO/IEC Guide 98-3 can be applied in practice for this International Standard.

This annex complements Clause 11.

C.2 Considerations on the total standard deviation, σ_{tot}

The measurement uncertainty used in this International Standard is determined by the expanded measurement uncertainty, U , which is derived directly from the total standard deviation, σ_{tot} [Equation (13)], with σ_{tot} being the approximation of the relevant $u(L_p)$ as defined in ISO/IEC Guide 98-3.

This total standard deviation, σ_{tot} , results from the two components, σ_{R0} and σ_{omc} [see Equation (12)], which are significantly different in nature.

Both quantities are assumed to be statistically independent and are determined separately.

The machinery-specific standard deviation, σ_{omc} , cannot be calculated and has to be determined by repeated measurements as described in C.3. Information on the standard deviation, σ_{R0} , is given in C.4.

C.3 Considerations on σ_{omc}

The standard deviation, σ_{omc} , described in 11.2, is calculated by

$$\sigma_{\text{omc}} = \sqrt{\frac{1}{N-1} \sum_{j=1}^N (L'_{p,j} - \overline{L'_p})^2} \text{ dB} \quad (\text{C.1})$$

where

$L'_{p,j}$ is the sound pressure level measured at a prescribed position for the j th repetition of the prescribed operating and mounting conditions;

$\overline{L'_p}$ is the mean sound pressure level calculated for all N repetitions.

These measurements are carried out under the actual *in situ* environmental conditions. Consequently $L'_{p,j}$ and $\overline{L'_p}$ do not need any further correction.

In general, the mounting and operating conditions to be used for noise emission measurements are prescribed by machinery-specific noise test codes. Otherwise, these conditions have to be defined precisely and described in the test report.

Some recommendations for defining these conditions and consequences for the expected values of σ_{omc} are given hereafter.

The test conditions have to represent normal usage and to conform to manufacturers' and users' recommended practice. However, even in normal usage, slightly different modes of operation, variations in material flow and other conditions varying between different phases of operation may occur. This uncertainty covers both the uncertainty due to variation in long-term operating conditions (e.g. from day to day) and fluctuations of noise emission measurements repeated immediately after readjusting mounting and operating conditions.

Machines that stand exclusively on soft springs or on heavy concrete floors do not normally exhibit any effect of mounting. However, there can be large discrepancies between measurements on heavy concrete floors and those made *in situ*. The uncertainty due to mounting can be highest for machinery that is connected to auxiliary equipment. Hand-held machines may also cause problems. This parameter should be investigated if movement of the machine or mounts causes changes in noise. If there is a range of possible mounting conditions to be included in a single declaration, then σ_{omc} is estimated from the standard deviation of the sound levels for these mounting conditions. If there is any known effect due to mounting, recommended mounting conditions should be documented in the relevant noise test code or manufacturers' recommended practice.

With respect to the main uncertainty quantity, σ_{tot} , investigations on σ_{omc} have a higher priority compared to those on the other uncertainty components leading to σ_{R0} [see Equation (12)]. This is because σ_{omc} may be significantly larger in practice than, for example, $\sigma_{R0} = 1,5$ dB for accuracy grade 2 or $\sigma_{R0} = 3$ dB for accuracy grade 3 measurements as given in Table 1.

If $\sigma_{\text{omc}} > \sigma_{R0}$, the application of measurement procedures with a high accuracy, i.e. a low value of σ_{R0} , makes no sense economically because this is not going to result in a lower value of the total uncertainty.

Table C.1 — Examples of calculated total standard deviations, σ_{tot} , for 3 different cases

Standard deviation of reproducibility of the method σ_{R0} dB	Operating and mounting conditions		
	stable	unstable	very unstable
	Standard deviation, σ_{omc} , dB		
	0,5	2	4
	Total standard deviation, σ_{tot} , dB		
1,5 (Accuracy grade 2)	1,6	2,5	4,3
3 (Accuracy grade 3)	3,0	3,6	5,0

These examples show that it can be superfluous to extend the measuring effort to ensure a measurement of accuracy grade 2 if the uncertainty associated with the mounting and operating conditions is large.

Furthermore $\sigma_{\text{omc}} > \sigma_{R0}$ may create substantial misunderstandings with respect to the true relevant total standard deviation, σ_{tot} , because the different grades of accuracy of this International Standard are currently defined by the value of σ_{R0} only.

C.4 Considerations on σ_{R0}

C.4.1 General

Upper bound values of σ_{R0} are given in Table 1. Additionally, in 11.3 it is recommended to investigate values of σ_{R0} that are relevant to individual machines or machine families in order to achieve more realistic values. These investigations are to be carried out either by measurements under reproducibility conditions as defined in ISO 3534-2^[2] or by calculations using the so-called modelling approach based on Equation (15) which requires more detailed information.

If certain uncertainty components are not relevant for specific applications or are difficult to investigate, delimited definitions of σ_{R0} should be given by noise test codes both for round robin tests (see 11.3.2, fourth paragraph) and for the modelling approach analogously.

The modelling approach, however, implies both, statistically independent components $c_i u_i$ and especially the existence of equations which can assess these uncertainty components by considering measurement parameters and environmental conditions or by at least reasonable experience. Relevant well-founded data for this International Standard were not available at the time of publication. However, the following information may give a rough impression of the relevant quantities without final reliability.

C.4.2 Contributions to the uncertainty, σ_{R0}

Preliminary estimations show that the general expression for the calculation of the final result of the emission sound pressure level measurement, including all corrections prescribed by this International Standard and with all relevant uncertainties, L_p , is given by Equation (C.2):

$$L_p = L_p (L'_p, \delta_{(B)}, \delta_{\text{env}}, \delta_{\text{slm}}, \delta_{\text{mount}}, \delta_{\text{oc}}, \delta_{\text{pos}}, \delta_{\text{met}}) \quad (\text{C.2})$$

where

- L'_p is the measured (uncorrected) sound pressure level;
- $\delta_{(B)}$ is an input quantity to allow for any uncertainty on background noise corrections;
- δ_{env} is an input quantity to allow for any uncertainty due to the local environmental influence;
- δ_{slm} is an input quantity to allow for any uncertainty in the measuring instrumentation;
- δ_{mount} is an input quantity to allow for any variability in the mounting conditions of the source under test;
- δ_{oc} is an input quantity to allow for any deviation in the operating conditions of the source under test from the nominal conditions;
- δ_{pos} is an input quantity to allow for any uncertainty in selection of the measuring position;
- δ_{met} is an input quantity to allow for any uncertainty in determining the meteorological conditions.

NOTE 1 Similar expressions to that of Equation (C.2) apply with respect to emission sound pressure levels determined in frequency bands and with A-weighting applied.

NOTE 2 The input quantities included in Equation (C.2) to allow for uncertainties are those thought to be applicable at the state of knowledge at the time of publication of this International Standard, but further research could reveal that there are others.

A probability distribution (normal, rectangular, Student t , etc.) is associated with each of the input quantities. Its expectation (mean value) is the best estimate for the value of the input quantity and its standard deviation is a measure of the dispersion of values, termed uncertainty.

The uncertainty components δ_{mount} and δ_{oc} are already covered by σ_{omc} whereas σ_{R0} includes the rest of the uncertainty components.

Table C.2 provides, as an example for accuracy grade 2, some information about present expectations concerning the values for the components, c_i, u_i , that are necessary for calculating $\sigma_{R0} = \sqrt{\sum_i (c_i u_i)^2}$ dB.

Table C.2 — Uncertainty budget for determinations of emission sound pressure level
(the values shown are examples related to accuracy grade 2 determinations)

Quantity	Estimate dB	Standard uncertainty, u_i dB	Probability distribution	Sensitivity coefficient, c_i	Uncertainty contribution, $c_i u_i$ dB
L_p					
L'_p	$\overline{L'_p}$	$s_{L'_p}$ (e.g. 0,5)	Normal	1,25	0,63
$\delta_{(B)}$	K_1	e.g. 0,7	Normal	-0,25	-0,18
δ_{env}	K_3 (e.g. 2)	$0,3K_3$	Normal	1	0,6
δ_{slm}	0	0,5	Normal	1	0,5
δ_{pos}	0	0,2	Normal	1	0,2
δ_{met}	0	0,3	Normal	1	0,3
$\sigma_{R0} = \sqrt{\sum_i (c_i u_i)^2}$ dB = 1,1 dB					

In Table C.2, the values of the standard uncertainties given are used to calculate the uncertainty contributions given in the right-hand column. The calculation of σ_{R0} assumes that the individual uncertainty contributions are not correlated.

The standard uncertainties from some contributions remain to be established by research.

Explanations for the uncertainty parameters in Table C.2 follow.

$u_{L'_p}$ Uncertainty associated with the sound pressure level measured at the work station. It is obtained from the standard deviation of repeated measurements of this level:

$$s_{L'_p} = \sqrt{\frac{1}{N-1} \sum_j (\overline{L'_p} - L'_{p,j})^2} \text{ dB}$$

$c_{L'_p}$ Sensitivity coefficient associated with the uncertainty in L'_p . It is the derivative of L_p with respect to L'_p under the condition $L_p = L'_p + 10 \lg \left\{ 1 - 10^{-0,1[L'_p - L_{p(B)}]} \right\}$ dB where $L_{p(B)}$ is the measured sound pressure level of the background noise, and where corrections to be used supplementary to Equation (7) are assumed to be independent from L'_p :

$$c_{L'_p} = \frac{\partial L_p}{\partial L'_p} = \frac{1}{1 - 10^{-0,1[L'_p - L_{p(B)}]}}$$

For the exemplary values in Table C.2 the difference between L'_p and $L_{p(B)}$ is assumed to be 7 dB, resulting in $c_{L'_p} = 1,25$.

$u_{(B)}$ Uncertainty in determining the background noise correction. In accordance with Equation (7), this uncertainty is a function of the measured difference $\Delta L = L'_p - L_{p(B)}$ only if the insufficiency of Equation (9) for different sound field conditions is neglected. Assuming $u_{L'_p} = u_{L_{p(B)}} = 0,5$ dB, this results in $u_{(B)} = \sqrt{0,5^2 + 0,5^2} = 0,7$ dB.

$c_{(B)}$ Sensitivity coefficient due to the uncertainty in the background noise correction. Based on Equation (9), where L_p is expressed by $L_p = L'_p - K_1(\Delta L) + \kappa$, where κ is a constant, this sensitivity coefficient is given by $c_{(B)} = \frac{\partial L_p}{\partial (\Delta L)} = \frac{1}{1 - 10^{0,1 \Delta L}}$.

For the exemplary values in Table C.2, ΔL is assumed to be 7 dB, resulting in $c_{(B)} = -0,25$.

u_{env} Uncertainty due to influences of the environment. From empirical experience, it is known that the uncertainty on K_3 can roughly be expressed as $K_3 \pm K_3/2$, where a rectangular distribution is assumed (total spread of values $\pm K_3/2$). Then the standard deviation can be calculated from $u = \frac{K_3}{2\sqrt{3}} \approx 0,3 K_3$.

c_{env} Sensitivity coefficient due to the uncertainty caused by environmental influences; $c_{env} = 1$.

u_{slm} Uncertainty in the measuring instrumentation. For a class 1 instrument, the value of this parameter is $u_{slm} = 0,5$ dB.

c_{slm} Uncertainty in the sound level meter directly affects measured levels, so that $c_{slm} = 1$, and the total uncertainty contribution is 0,5 dB. Additional details regarding parameters affecting the uncertainty of sound level meters can be found in IEC 61672-1.

u_{pos} Uncertainty due to the selection of the measuring position. An estimated value from experience with packaging machinery is 0,2. It can be determined individually for a given type of source by repeating measurements with and without removing and installing again the microphone between these measurements.

c_{pos} Sensitivity coefficient due to the selection of the measuring position; $c_{pos} = 1$.

u_{met} Uncertainty in determining the meteorological corrections (see 5.5). If the correction for meteorological conditions is applied, the value for this parameter is $u_{met} = 0,2$ dB.

At 120 m elevation and 23 °C the correction is zero and at 500 m elevation the correction is 0,6 dB. Assuming a rectangular distribution for this uncertainty, the standard deviation is $s_{\text{met}} = 0,6 / \sqrt{3} = 0,3 \text{ dB}$. For elevations less than 500 m above sea level, no meteorological correction is required for accuracy grade 2 measurements.

c_{met} In the general case, the standard deviation is 0,3 dB with corresponding uncertainty contribution of 0,3 dB. Therefore, $c_{\text{met}} = 1$. A lower uncertainty contribution can be obtained by measuring in a different location, or by applying the meteorological correction.

C.5 Combined standard uncertainty

In the case of negligible correlation between the input quantities, the combined standard uncertainty of the determination of the emission sound pressure level, $u(L_p)$, in decibels, is given by Equation (C.3):

$$u(L_p) \approx \sigma_{\text{tot}} = \sqrt{\sigma_{R0}^2 + \sigma_{\text{omc}}^2} = \sqrt{\sum_i (c_i u_i)^2 + \sigma_{\text{omc}}^2} \quad (\text{C.3})$$

C.6 Measurement uncertainty based on reproducibility data

In the absence of data for uncertainty contributions and possible correlations between input quantities, values for the standard deviation of reproducibility as given in Clause 11 may be used as an estimate of the combined standard uncertainty of determinations of emission sound pressure levels, $u(L_p)$. A value may then be selected for the coverage factor, k , and the product of $k \sigma_{\text{tot}}$ yields an estimate of the expanded measurement uncertainty, U , with the chosen coverage probability. By convention, a coverage probability of 95 % is usually chosen, and assuming a normal distribution, the associated two-sided coverage factor is 2. To avoid misinterpretation, the coverage probability should be stated in test reports, together with the expanded measurement uncertainty.

Annex D (informative)

Principles of the methodology

The emission sound pressure level, L_p , is produced by the direct sound field at the work station of a source under test. This is exactly the level at this work station if the source under test is operated in a hemi-free field without any other sources.

If the source under test is operated in a room, an additional sound field is produced. The corresponding sound pressure level of this “room sound field”, L_{room} , depends on the sound power level of the source, L_W , and the acoustical properties of the room. These can be characterized in many cases approximately by the equivalent absorption area, A . The sound pressure level at the work station of the source under test operating in a room is thus the energy sum of the emission sound pressure level, L_p , and the level of this “room sound field”, L_{room} .

The difference of the level at the work station with the source under test operating in the room and operating in a hemi-free field is exactly the local environmental correction, K_3 . It depends on the difference between the sound power level and the emission sound pressure level of the source under test and on the acoustic room properties expressed as absorption area, A .

It can be shown that these hemi-free-field values, L_p and L_W , in the equation defining the local environmental correction, K_3 , can be replaced by quantities measured with the source under test operating in the room. After reformulating the equation defining K_3 , this quantity can be determined using the difference between the sound pressure level at the work station, L_p^* , and the mean sound pressure level, $\overline{L_p^*}$, on the measurement surface used for the determination of the sound power level (both levels are uncorrected for environmental influence, but corrected for background noise), the area of this measurement surface, S , and again the absorption area, A , characterizing the room.

Defining this level difference, $L_p^* - \overline{L_p^*}$, as apparent work station directivity index, $D_{1\text{op}}^*$, and replacing the area, S , of the measurement surface and the equivalent absorption area, A , by the environmental correction, K_2 , the local environmental correction, K_3 , can be determined from $D_{1\text{op}}^*$ and K_2 .

This International Standard describes a method to determine the local environmental correction, K_3 , from measurements of the source radiation and the acoustic room properties.

The source radiation is taken into account measuring the mean sound pressure level, $\overline{L_p^*}$, on the enveloping measurement surface, S , and the sound pressure level at the work station, L_p^* . From these two levels, the apparent work station directivity, $D_{1\text{op}}^*$, is calculated.

In the method specified in A.2, the acoustic room properties are described by the environmental correction, K_2 , related to the same enveloping measurement surface, S . Guidance is given to determine the local environmental correction, K_3 , from K_2 and $D_{1\text{op}}^*$.

In the method specified in A.3, the acoustic room properties are described by the equivalent absorption area, A . Guidance is given to determine the local environmental correction, K_3 , from A , S and $D_{1\text{op}}^*$.

The methods, derivations and uncertainties are based on investigations reported in References [25][26][27].

Annex E (informative)

Example of a test table

The design for a test table is shown in Figure E.1. In this example the top of the table has lateral dimensions of $0,75 \text{ m} \pm 0,03 \text{ m}$ and is made of bonded laminated wood, $0,04 \text{ m}$ to $0,10 \text{ m}$ thick. The height of the table is $0,75 \text{ m} \pm 0,03 \text{ m}$.

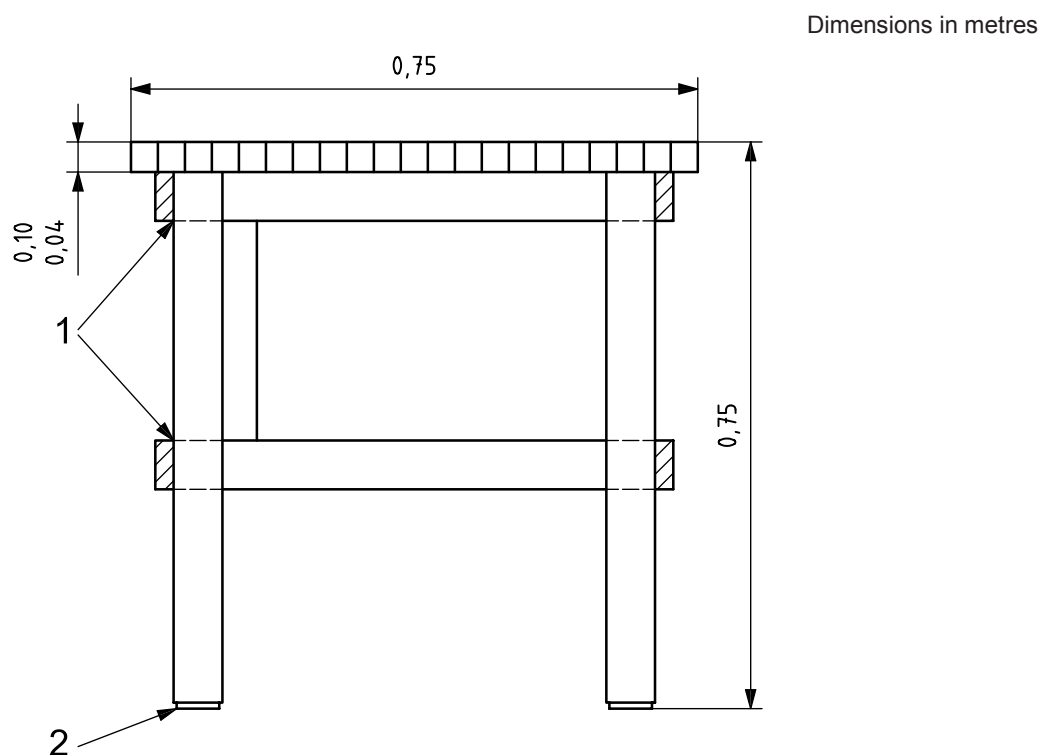

Key

- 1 legs and braces: screwed and bonded
- 2 isolating pads

Figure E.1 — Example of a test table

Bibliography

- [1] ISO 1996-1, *Acoustics — Description, measurement and assessment of environmental noise — Part 1: Basic quantities and assessment procedures*
- [2] ISO 3534-2, *Statistics — Vocabulary and symbols — Part 2: Applied statistics*
- [3] ISO 3740, *Acoustics — Determination of sound power levels of noise sources — Guidelines for the use of basic standards*
- [4] ISO 3741, *Acoustics — Determination of sound power levels and sound energy levels of noise sources using sound pressure — Precision methods for reverberation test rooms*
- [5] ISO 3743-1, *Acoustics — Determination of sound power levels of noise sources — Engineering methods for small, movable sources in reverberant fields — Part 1: Comparison method for hard-walled test rooms*
- [6] ISO 3743-2, *Acoustics — Determination of sound power levels of noise sources using sound pressure — Engineering methods for small, movable sources in reverberant fields — Part 2: Methods for special reverberation test rooms*
- [7] ISO 3745, *Acoustics — Determination of sound power levels of noise sources using sound pressure — Precision methods for anechoic and hemi-anechoic rooms*
- [8] ISO 3747, *Acoustics — Determination of sound power levels and sound energy levels of noise sources using sound pressure — Engineering/survey methods for use in situ in a reverberant environment*
- [9] ISO 4871, *Acoustics — Declaration and verification of noise emission values of machinery and equipment*
- [10] ISO 6926, *Acoustics — Requirements for the performance and calibration of reference sound sources used for the determination of sound power levels*
- [11] ISO 7574-1, *Acoustics — Statistical methods for determining and verifying stated noise emission values of machinery and equipment — Part 1: General considerations and definitions*
- [12] ISO 9614-1, *Acoustics — Determination of sound power levels of noise sources using sound intensity — Part 1: Measurement at discrete points*
- [13] ISO 9614-2, *Acoustics — Determination of sound power levels of noise sources using sound intensity — Part 2: Measurement by scanning*
- [14] ISO 9614-3, *Acoustics — Determination of sound power levels of noise sources using sound intensity — Part 3: Precision method for measurement by scanning*
- [15] ISO 11200, *Acoustics — Noise emitted by machinery and equipment — Guidelines for the use of basic standards for the determination of emission sound pressure levels at a work station and at other specified positions*
- [16] ISO 11201, *Acoustics — Noise emitted by machinery and equipment — Determination of emission sound pressure levels at a work station and at other specified positions in an essentially free field over a reflecting plane with negligible environmental corrections*
- [17] ISO 11202, *Acoustics — Noise emitted by machinery and equipment — Determination of emission sound pressure levels at a work station and at other specified positions applying approximate environmental corrections*

- [18] ISO 11203, *Acoustics — Noise emitted by machinery and equipment — Determination of emission sound pressure levels at a work station and at other specified positions from the sound power level*
- [19] ISO 11205, *Acoustics — Noise emitted by machinery and equipment — Engineering method for the determination of emission sound pressure levels in situ at the work station and at other specified positions using sound intensity*
- [20] ISO/TR 11690-3, *Acoustics — Recommended practice for the design of low-noise workplaces containing machinery — Part 3: Sound propagation and noise prediction in workrooms*
- [21] ISO/TR 25417:2007, *Acoustics — Definitions of basic quantities and terms*
- [22] JONASSON, H.G., OLOFSSON, J. *Measurement of impulse noise*. Borås: Swedish National Testing and Research Institute, 1997. 51 p. (SP Report 1997:38.)
- [23] JONASSON, H.G. *Determination of emission sound pressure level and sound power level in situ*. Borås: Swedish National Testing and Research Institute, 1999. 80 p. (SP Report 1999:18.)
- [24] OLOFSSON, J., JONASSON, H.G. *Measurement of impulse noise — An inter-Nordic comparison*. Borås: SP, 1998. 28 p. (Nordtest Report 426, SP Report 1998:47.)
- [25] PROBST, W. *Checking of sound emission values*. Bundesanstalt für Arbeitsschutz und Arbeitsmedizin, Dortmund, 1999. 102 p. (Report Fb 851.)
- [26] PROBST, W. *Untersuchung der Einflussgrößen auf die Ermittlung der Emissionsschalldruckpegel von Maschinen* [Investigation of the quantities influencing the determination of the emission sound pressure levels of machinery]. Bundesanstalt für Arbeitsschutz und Arbeitsmedizin, Dortmund, 2002. 79 p. (Report Fb 968.)
- [27] PROBST, W. *Improvements in the determination of the emission sound pressure level of machines*. Bundesanstalt für Arbeitsschutz und Arbeitsmedizin, Dortmund, 2004. 116 p. (Report Fb 1034.)
- [28] HÜBNER, G., SEHRNDT, G.A. Accuracy consideration in sound power measurement for noise radiated by machines under free field conditions. In: *Proceedings of the 6th International Congress on Acoustics (ICA)*, Tokyo, 1968
- [29] HÜBNER, G. Analysis of errors in measuring machine noise under free-field conditions. *J. Acoust. Soc. Am.* 1973, **54**, pp. 967-977
- [30] HÜBNER, G., WU, J., MESSNER, J. *Ringversuch zur Bestimmung des Schalleistungspegels* [Interlaboratory test for the determination of sound-power level]. Bundesanstalt für Arbeitsschutz und Arbeitsmedizin, Dortmund, 1996. 395 p. (Report Fb 736.)
- [31] HÜBNER, G. Final results of a national round robin test determining the sound power level of machines/equipment. In: *Proceedings of InterNoise 1997*, Budapest, 1997¹⁾
- [32] HÜBNER, G. Remarks on the *Guide to the expression of uncertainty in measurement* (GUM) published by ISO and other international organizations — Floating error analysis for an acoustic example. In: *Proceedings of InterNoise 2002*, Dearborn, MI, 2002
- [33] HÜBNER, G. Accuracy consideration on the meteorological correction for a normalized sound power. In: *Proceedings of InterNoise 2000*, Nice, 2000

1) Summary of Reference [30].

British Standards Institution (BSI)

BSI is the national body responsible for preparing British Standards and other standards-related publications, information and services.

BSI is incorporated by Royal Charter. British Standards and other standardization products are published by BSI Standards Limited.

About us

We bring together business, industry, government, consumers, innovators and others to shape their combined experience and expertise into standards-based solutions.

The knowledge embodied in our standards has been carefully assembled in a dependable format and refined through our open consultation process. Organizations of all sizes and across all sectors choose standards to help them achieve their goals.

Information on standards

We can provide you with the knowledge that your organization needs to succeed. Find out more about British Standards by visiting our website at bsigroup.com/standards or contacting our Customer Services team or Knowledge Centre.

Buying standards

You can buy and download PDF versions of BSI publications, including British and adopted European and international standards, through our website at bsigroup.com/shop, where hard copies can also be purchased.

If you need international and foreign standards from other Standards Development Organizations, hard copies can be ordered from our Customer Services team.

Subscriptions

Our range of subscription services are designed to make using standards easier for you. For further information on our subscription products go to bsigroup.com/subscriptions.

With **British Standards Online (BSOL)** you'll have instant access to over 55,000 British and adopted European and international standards from your desktop. It's available 24/7 and is refreshed daily so you'll always be up to date.

You can keep in touch with standards developments and receive substantial discounts on the purchase price of standards, both in single copy and subscription format, by becoming a **BSI Subscribing Member**.

PLUS is an updating service exclusive to BSI Subscribing Members. You will automatically receive the latest hard copy of your standards when they're revised or replaced.

To find out more about becoming a BSI Subscribing Member and the benefits of membership, please visit bsigroup.com/shop.

With a **Multi-User Network Licence (MUNL)** you are able to host standards publications on your intranet. Licences can cover as few or as many users as you wish. With updates supplied as soon as they're available, you can be sure your documentation is current. For further information, email bsmusales@bsigroup.com.

BSI Group Headquarters

389 Chiswick High Road London W4 4AL UK



Revisions

Our British Standards and other publications are updated by amendment or revision.

We continually improve the quality of our products and services to benefit your business. If you find an inaccuracy or ambiguity within a British Standard or other BSI publication please inform the Knowledge Centre.

Copyright

All the data, software and documentation set out in all British Standards and other BSI publications are the property of and copyrighted by BSI, or some person or entity that owns copyright in the information used (such as the international standardization bodies) and has formally licensed such information to BSI for commercial publication and use. Except as permitted under the Copyright, Designs and Patents Act 1988 no extract may be reproduced, stored in a retrieval system or transmitted in any form or by any means – electronic, photocopying, recording or otherwise – without prior written permission from BSI. Details and advice can be obtained from the Copyright & Licensing Department.

Useful Contacts:

Customer Services

Tel: +44 845 086 9001

Email (orders): orders@bsigroup.com

Email (enquiries): cservices@bsigroup.com

Subscriptions

Tel: +44 845 086 9001

Email: subscriptions@bsigroup.com

Knowledge Centre

Tel: +44 20 8996 7004

Email: knowledgecentre@bsigroup.com

Copyright & Licensing

Tel: +44 20 8996 7070

Email: copyright@bsigroup.com

...making excellence a habit.™