

BS EN ISO 11064-4:2013



BSI Standards Publication

# Ergonomic design of control centres

Part 4: Layout and dimensions of workstations (ISO 11064-4:2013)

**bsi.**

...making excellence a habit.™

**National foreword**

This British Standard is the UK implementation of EN ISO 11064-4:2013. It supersedes BS EN ISO 11064-4:2004 which is withdrawn.

The UK participation in its preparation was entrusted to Technical Committee PH/9, Applied ergonomics.

A list of organizations represented on this committee can be obtained on request to its secretary.

This publication does not purport to include all the necessary provisions of a contract. Users are responsible for its correct application.

© The British Standards Institution 2013. Published by BSI Standards Limited 2013

ISBN 978 0 580 70331 7

ICS 13.180

**Compliance with a British Standard cannot confer immunity from legal obligations.**

This British Standard was published under the authority of the Standards Policy and Strategy Committee on 30 November 2013.

**Amendments issued since publication**

Date	Text affected
------	---------------

---

English Version

## Ergonomic design of control centres - Part 4: Layout and dimensions of workstations (ISO 11064-4:2013)

Conception ergonomique des centres de commande -  
Partie 4: Agencement et dimensionnement du poste de  
travail (ISO 11064-4:2013)

Ergonomische Gestaltung von Leitzentralen - Teil 4:  
Auslegung und Maße von Arbeitsplätzen (ISO 11064-  
4:2013)

This European Standard was approved by CEN on 24 August 2013.

CEN members are bound to comply with the CEN/CENELEC Internal Regulations which stipulate the conditions for giving this European Standard the status of a national standard without any alteration. Up-to-date lists and bibliographical references concerning such national standards may be obtained on application to the CEN-CENELEC Management Centre or to any CEN member.

This European Standard exists in three official versions (English, French, German). A version in any other language made by translation under the responsibility of a CEN member into its own language and notified to the CEN-CENELEC Management Centre has the same status as the official versions.

CEN members are the national standards bodies of Austria, Belgium, Bulgaria, Croatia, Cyprus, Czech Republic, Denmark, Estonia, Finland, Former Yugoslav Republic of Macedonia, France, Germany, Greece, Hungary, Iceland, Ireland, Italy, Latvia, Lithuania, Luxembourg, Malta, Netherlands, Norway, Poland, Portugal, Romania, Slovakia, Slovenia, Spain, Sweden, Switzerland, Turkey and United Kingdom.



EUROPEAN COMMITTEE FOR STANDARDIZATION  
COMITÉ EUROPÉEN DE NORMALISATION  
EUROPÄISCHES KOMITEE FÜR NORMUNG

**CEN-CENELEC Management Centre: Avenue Marnix 17, B-1000 Brussels**

## Foreword

This document (EN ISO 11064-4:2013) has been prepared by Technical Committee ISO/TC 159 "Ergonomics" in collaboration with Technical Committee CEN/TC 122 "Ergonomics" the secretariat of which is held by DIN.

This European Standard shall be given the status of a national standard, either by publication of an identical text or by endorsement, at the latest by May 2014, and conflicting national standards shall be withdrawn at the latest by May 2014.

Attention is drawn to the possibility that some of the elements of this document may be the subject of patent rights. CEN [and/or CENELEC] shall not be held responsible for identifying any or all such patent rights.

This document supersedes EN ISO 11064-4:2004.

According to the CEN-CENELEC Internal Regulations, the national standards organizations of the following countries are bound to implement this European Standard: Austria, Belgium, Bulgaria, Croatia, Cyprus, Czech Republic, Denmark, Estonia, Finland, Former Yugoslav Republic of Macedonia, France, Germany, Greece, Hungary, Iceland, Ireland, Italy, Latvia, Lithuania, Luxembourg, Malta, Netherlands, Norway, Poland, Portugal, Romania, Slovakia, Slovenia, Spain, Sweden, Switzerland, Turkey and the United Kingdom.

### Endorsement notice

The text of ISO 11064-4:2013 has been approved by CEN as EN ISO 11064-4:2013 without any modification.

# Contents

Page

<b>Foreword</b> .....	<b>iv</b>
<b>Introduction</b> .....	<b>v</b>
<b>1 Scope</b> .....	<b>1</b>
<b>2 Normative references</b> .....	<b>1</b>
<b>3 Terms and definitions</b> .....	<b>1</b>
<b>4 Initial control workstation layout considerations</b> .....	<b>3</b>
<b>5 Factors determining control workstation design</b> .....	<b>4</b>
5.1 General user considerations.....	5
5.2 Visual tasks.....	9
5.3 Auditory tasks.....	10
5.4 Working postures.....	10
<b>6 Control workstation layout</b> .....	<b>12</b>
6.1 General layout considerations.....	13
6.2 Layout requirements.....	14
<b>7 Control workstation dimensions</b> .....	<b>17</b>
7.1 Dimension considerations.....	17
7.2 Seated control workstations.....	17
7.3 Standing control workstations.....	18
<b>Annex A (informative) Arranging displays and control workstations</b> .....	<b>19</b>
<b>Annex B (informative) Conformance matrix</b> .....	<b>30</b>
<b>Bibliography</b> .....	<b>37</b>

## Foreword

ISO (the International Organization for Standardization) is a worldwide federation of national standards bodies (ISO member bodies). The work of preparing International Standards is normally carried out through ISO technical committees. Each member body interested in a subject for which a technical committee has been established has the right to be represented on that committee. International organizations, governmental and non-governmental, in liaison with ISO, also take part in the work. ISO collaborates closely with the International Electrotechnical Commission (IEC) on all matters of electrotechnical standardization.

The procedures used to develop this document and those intended for its further maintenance are described in the ISO/IEC Directives, Part 1. In particular the different approval criteria needed for the different types of ISO documents should be noted. This document was drafted in accordance with the editorial rules of the ISO/IEC Directives, Part 2. [www.iso.org/directives](http://www.iso.org/directives)

Attention is drawn to the possibility that some of the elements of this document may be the subject of patent rights. ISO shall not be held responsible for identifying any or all such patent rights. Details of any patent rights identified during the development of the document will be in the Introduction and/or on the ISO list of patent declarations received. [www.iso.org/patents](http://www.iso.org/patents)

Any trade name used in this document is information given for the convenience of users and does not constitute an endorsement.

The committee responsible for this document is ISO/TC 159, *Ergonomics*, Subcommittee SC 4, *Ergonomics of human-system interaction*.

This second edition cancels and replaces the first edition (ISO 11064-4:2004), which has been technically revised.

ISO 11064 consists of the following parts, under the general title *Ergonomic design of control centres*:

- *Part 1: Principles for the design of control centres*
- *Part 2: Principles for the arrangement of control suites*
- *Part 3: Control room layout*
- *Part 4: Layout and dimensions of workstations*
- *Part 5: Displays and controls*
- *Part 6: Environmental requirements for control centres*
- *Part 7: Principles for the evaluation of control centres*

## Introduction

This part of ISO 11064 establishes ergonomic requirements, recommendations and guidelines for the design of workplaces in control centres.

All types of control centres are covered, including those for the process industry, transport and dispatching systems and emergency services. Although this part of ISO 11064 is primarily intended for non-mobile control centres, many of the principles are relevant to mobile centres such as those found on ships, locomotives and aircraft.

User requirements are a central theme of this part of ISO 11064 and the processes described are designed to take into account the needs of users at all design stages. The overall strategy for dealing with user requirements is presented in ISO 11064-1. ISO 11064-2 provides guidance on the design and planning of the control room in relation to its supporting areas. Requirements for the layout of the control room are covered by ISO 11064-3. Displays and controls, human computer interaction and the physical working environment are presented in ISO 11064-5 and ISO 11064-6. Evaluation principles are dealt with in ISO 11064-7.

The users of this standard are assumed to have some understanding of anthropometry, its use and limitations, and its application in the context of control rooms. Where this understanding is in doubt, it is recommended that the advice of an expert be sought.

The ultimate beneficiaries of this part of ISO 11064 will be the operator within the control room and other such users. It is the needs of these users that provide the ergonomic requirements that are addressed by the International Standards developers. Although it is unlikely that the end user will read this International Standard, or even know of its existence, its application should provide the user with interfaces that are more usable and a working environment which is more consistent with operational demands, and result in a solution which will improve system performance, minimize error and enhance productivity.





# Ergonomic design of control centres —

## Part 4: Layout and dimensions of workstations

### 1 Scope

This part of ISO 11064 specifies ergonomic principles, recommendations and requirements for the design of workstations found in control centres. It covers control workstation design with particular emphasis on layout and dimensions. It is applicable primarily to seated, visual-display-based workstations, although control workstations at which operators stand are also addressed. These different types of control workstation are to be found in applications such as transportation control, process control and security installations. Most of these workstations now incorporate flat-display screens for the presentation of information.

### 2 Normative references

The following documents, in whole or in part, are normatively referenced in this document and are indispensable for its application. For dated references, only the edition cited applies. For undated references, the latest edition of the referenced document (including any amendments) applies.

ISO 7250-1:2008, *Basic human body measurements for technological design — Part 1: Body measurement definitions and landmarks*

ISO 9241-410:2008, *Ergonomics of human-system interaction — Part 410: Design criteria for physical input devices*

ISO 9241-5:1998, *Ergonomic requirements for office work with visual display terminals (VDTs) — Part 5: Workstation layout and postural requirements*

ISO 11064-3:1999, *Ergonomic design of control centres — Part 3: Control room layout*

ISO 11428:1996, *Ergonomics — Visual danger signals — General requirements, design and testing*

### 3 Terms and definitions

For the purposes of this part of ISO 11064, the following terms and definitions apply.

#### 3.1

##### **control workstation**

single or multiple working position, including all equipment such as computers and communication terminals and furniture at which control and monitoring functions are conducted

[SOURCE: ISO 11064-3:1999, 3.7.]

#### 3.2

##### **cone of fixations**

angular extent to which the line of sight can be swept by rotating the eyeball in the skull while the head rests

### 3.3

#### **legibility**

ability for unambiguous identification of single characters or symbols that may be presented in a non-contextual format

[SOURCE: ISO 9241-302:2008, 3.3.35.]

### 3.4

#### **line-of-sight**

line connecting the point of fixation and the centre of the pupil

Note 1 to entry: The line-of-sight with two eyes is the line connecting the point of fixation and the midpoint between the two pupils

[SOURCE: ISO 9241-302:2008, 3.3.36.]

### 3.5

#### **nearpoint**

nearest viewing distance to which the eye accommodates

### 3.6

#### **normal line-of-sight**

inclination of the line-of-sight with respect to the horizontal plane, when the muscles assigned for the orientation of the eyes are relaxed

### 3.7

#### **percentile**

value of a variable below which a certain percentage of observations fall

### 3.8

#### **reach envelope**

three-dimensional space in which an operator can comfortably reach and manipulate controls by either hand while assuming a posture normally anticipated for the task

### 3.9

#### **task zone**

space determined by the equipment and activities required for the conduct of a particular task

### 3.10

#### **visual angle**

angle subtended at the eye by the viewed object, e.g. a character or symbol

### 3.11

#### **visual field, field of vision**

physical space visible to an eye in a given position

[SOURCE: ISO 8995:1989, 3.1.10.]

Note 1 to entry: In this standard the use of both eyes is assumed for visual field considerations.

Note 2 to entry: The position of the visual field depends on the direction of the line-of-sight.

Note 3 to entry: Separate, distinct stimuli in the visual field will be detected even if they appear simultaneously.

Note 4 to entry: While the extent of the visual field is approximately  $\pm 35^\circ$  around the line-of-sight, only between  $1^\circ$  and  $2^\circ$  of these are for sharp vision.

### 3.12

#### **work environment**

physical, chemical, biological, organizational, social and cultural factors surrounding a worker

[SOURCE: ISO 6385:2004, 2.6.]

### 3.13

#### **work space**

volume allocated to one or more persons in the work system to complete the work task

[SOURCE: ISO 6385:2004, 2.15.]

### 3.14

#### **workstation**

combination of work equipment for a particular person in a work space

[SOURCE: ISO 11064-2:2000, 3.5.]

Note 1 to entry: It is possible that several persons may share a particular control workstation, or that several persons alternate several workstations within any period of time (i.e. on an hourly, daily, weekly basis).

### 3.15

#### **work task**

activity or set of activities required by the worker to achieve an intended outcome

[SOURCE: ISO 6385:2004, 2.17.]

## **4 Initial control workstation layout considerations**

The starting point for control workstation design (shape and dimensions) is a list of work tasks and related work characteristics. The human operator may need certain facilities, such as displays, input devices and communication equipment. Work space may also be required for special control-room-related tasks such as paper work. For each task, a compilation of the requirements of the associated devices is needed. By taking account of job designs, task zones are combined together into control workstation arrangements. The grouping of control workstations into control room layouts is discussed in ISO 11064-2 and ISO 11064-3.

Requirements identified for each task zone are inputs for the detailed engineering of control workstations.

A systematic approach to designing control workstations is presented in [Figure 1](#). The sequence of stages involved in this process may vary as a result of iterations, and this may have an impact on the appropriate tasks which need to be undertaken at each stage.

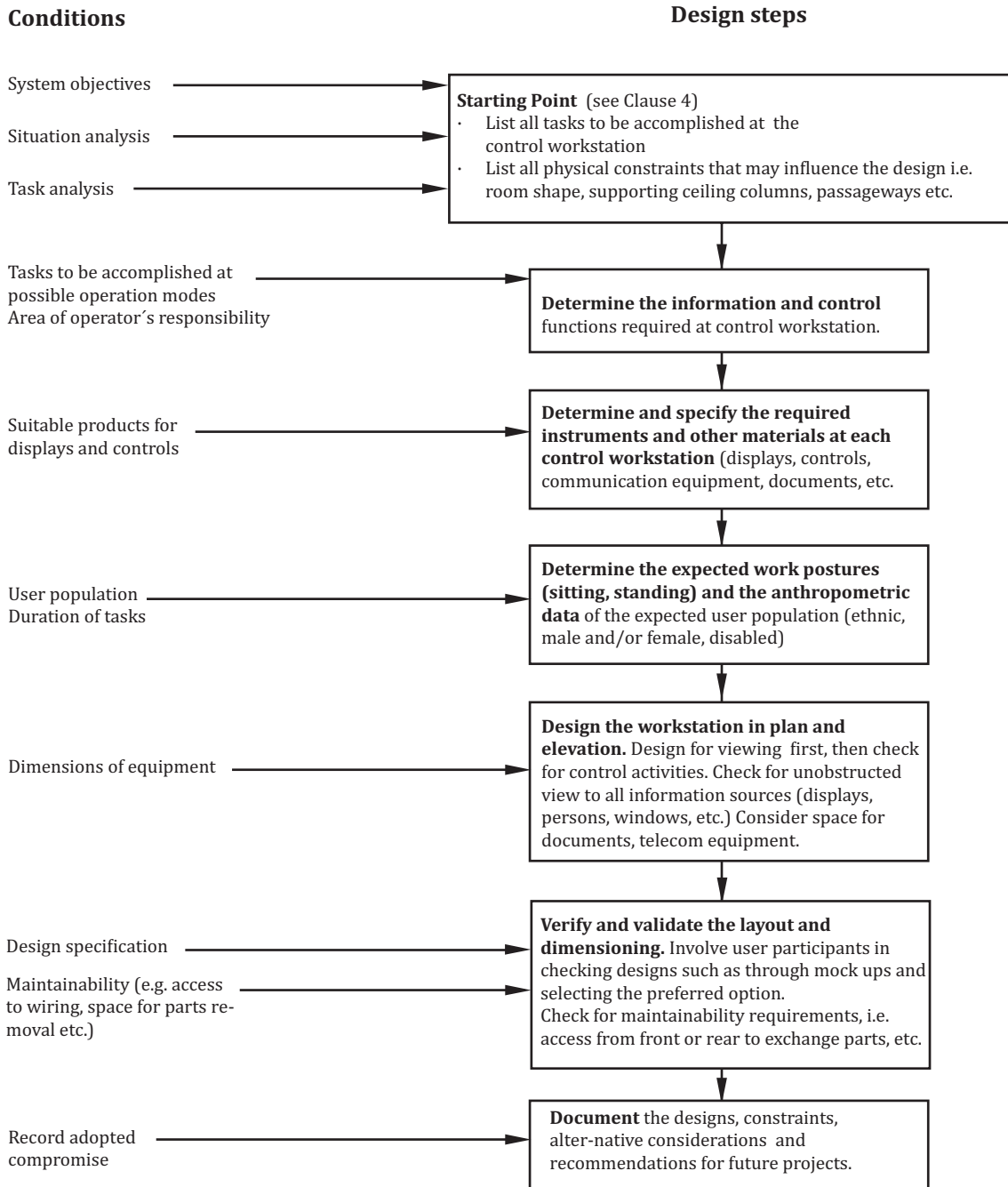

NOTE Each design stage in the process may result in a feedback loop to one of the earlier steps.

Figure 1 — Control workstation design steps

## 5 Factors determining control workstation design

This clause is mainly concerned with control workstations with one or more visual displays, communication tools and space for administrative functions and documentation.

## 5.1 General user considerations

### 5.1.1 General requirements

Workstations shall be designed to accommodate from the 5th to the 95th percentiles of dimensions of the intended user population. When considering the user population, account shall be taken of the demographic characteristics of the intended users, including gender, age, ethnic background and disabilities.

Workstations shall be designed according to human capabilities, limitations and needs. Consequently, the design shall take into consideration the physical characteristics of the user population, including working postures, visual and aural needs, reach envelopes and their collective influences on control workstation layout and dimensions.

### 5.1.2 User requirements

The layout and dimensioning of control workstations shall be governed by the anthropometric dimensions of the user and any requirements for movement to accomplish his/her tasks. Anthropometric data are usually given in terms of percentiles.

General anthropometric requirements are the following.

- a) The percentile values referred to in this part of ISO 11064 shall be computed from the set of anthropometric data of the expected user population.
- b) Control workstation dimensions shall accommodate at least a range from the 5th to the 95th percentile of the user population.
- c) The following anthropometric data shall be used to primarily determine the control workstation dimensions:
  - reach envelope: 5th percentile of the user population, e.g. reach to critical equipment;
  - clearances: 95th percentile of the user population, e.g. clearances under work surfaces.

The key anthropometric dimensions for consideration of a seated operator (in elevation) are shown in [Figure 2](#). [Figure 3](#) shows the anthropometric dimensions (in elevation) for consideration for a standing operator, and [Figure 4](#) shows the dimensions in plan view for seated and standing operators. Any design solution selected should not unnecessarily disadvantage members presenting extreme anthropometric dimensions of the user population. Design parameters proposed should be checked against the relevant characteristics of the user population.

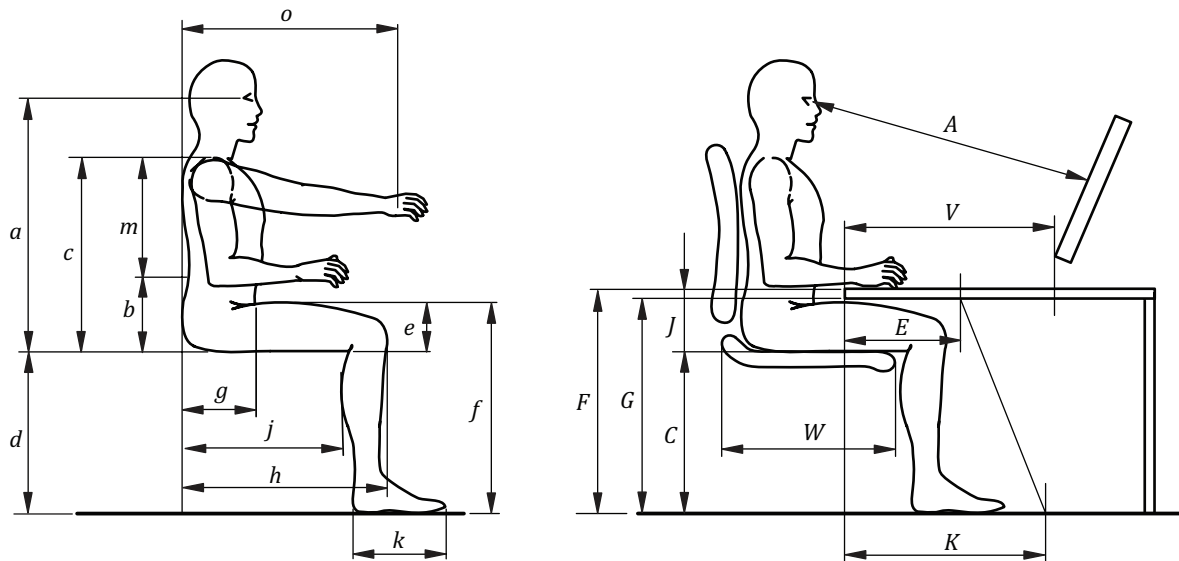

Anthropometric measurements			Control workstation dimensions		
Symbol	Description	ISO 7250-1:2008 subclause	Symbol	Description	Calculation
<i>a</i>	Eye height, sitting	4.2.2	<i>A</i>	Viewing distance <sup>a</sup>	
<i>b</i>	Elbow height, sitting	4.2.5	<i>C</i>	Seat pan height range <sup>b</sup>	$C = d$ plus shoe heel height minus comfort factor
<i>c</i>	Shoulder height, sitting	4.2.4	<i>E</i>	Horizontal clearance under <sup>c</sup> work surface at knee height	$E = h$ minus $g$
<i>d</i>	Lower leg length (popliteal height)	4.2.12	<i>F</i>	Work surface height <sup>d,j</sup>	$F = d$ plus $e$ plus shoe heel height plus seat cushion thickness plus work surface thickness
<i>e</i>	Thigh clearance	4.2.13	<i>G</i>	Vertical clearance under work surface <sup>e,10</sup>	$G = d$ plus $e$ plus shoe heel height plus seat cushion thickness
<i>f</i>	Top of thigh height	4.2.14	<i>J</i>	Armrest height (from seat pan) <sup>f</sup>	$J = b$ plus seat cushion thickness
<i>g</i>	Buttock abdomen depth sitting	4.2.17	<i>K</i>	Horizontal clearance at foot level <sup>g,k</sup>	$K = j$ minus $g$ plus $k$
<i>h</i>	Buttock knee length	4.4.7	<i>V</i>	Usable work surface depth <sup>h</sup>	
<i>j</i>	Buttock popliteal length	4.4.6	<i>W</i>	Seat pan depth <sup>i</sup>	$W = j$
<i>k</i>	Foot length	4.3.7			
<i>o</i>	Grip reach	4.4.2			
<i>m</i>	Shoulder elbow length	4.2.6			
<i>a</i>	Function of eye height, sitting and task requirements and equipment.				
<i>b</i>	Range — 5th percentile to 95th percentile.				
<i>c</i>	Use largest $h$ minus smallest $g$ .				
<i>d</i>	Fixed work surface height — use largest $d$ plus largest $e$ . Adjustable work surface height — range of $F$ calculated using (smallest $d$ and smallest $e$ ) and (largest $d$ and largest $e$ ).				
<i>e</i>	Fixed work surface height — use largest $d$ added to largest $e$ . Adjustable work surface height — range of $G$ calculated using (smallest $d$ and smallest $e$ ) and (largest $d$ and largest $e$ ).				
<i>f</i>	Range — use 5th percentile $b$ to 95th percentile $b$ .				
<i>g</i>	Use largest $j$ minus smallest $g$ plus largest $k$ .				
<i>h</i>	$V =$ derived from task and control equipment requirements.				
<i>i</i>	Use smallest $j$ .				
<i>j</i>	Maximum recommended work surface thickness 40 mm.				
<i>k</i>	This calculation will give maximum values — see recommendation in 5.4.2 for leg and feet clearances.				

**Figure 2 — Illustration of key anthropometric and control workstation dimensions associated with seated control workstation in elevation**

For standing vertical panels (see [Figure 3](#)), controls should not be so low that the standing-tall user must stoop to reach down to them.

Where no clothing allowances are specified in the anthropometric database, the dimensional effects of footwear and clothing shall be considered.

The effects of different postures shall be considered.

If it is impossible to cope with this range from the 5th percentile to the 95th with a fixed control workstation, an adjustable workstation shall be considered.

It may be necessary to combine anthropometric data, though caution should be exercised when doing this.

Usually, the native anthropometric data set is based on naked subjects. Some data sources, however, include clothing allowance on certain dimensions. The implications of wearing personal protective equipment should also be considered if a task analysis reveals that this is required.

The control workstation designers shall take account of the changes in eye position, relative to the location of equipment and the view over the workstation, when different postures are adopted by the operator (see [Table 2](#)).

NOTE Changing between the four postures of “bent forward”, “erect”, “reclined” and “relaxed” results in changes in the vertical position of the eyes and their relative position relative to the front edge of the workstation,

Another allowance concerns the so-called *slump factor* (a correction made to measurements taken from an erect posture), an attempt to simulate more natural and relaxed postures. In some sources, this factor is included; in others, not. Therefore, data sources should be checked carefully before being applied.

Typically, control workstations will be operated by multiple users who might exhibit a range of anthropometric features. Control workstation design and layout should take account of this variable user population.

Adjustable control workstations should be considered and accommodate at least a range from the 5th percentile to the 95th percentile of the determining body dimensions of the user population (see [7.2](#)).

Adjustment devices should be easy and safe to use from a seated position.

NOTE Reliability is an important design feature when incorporating adjustability in workstations

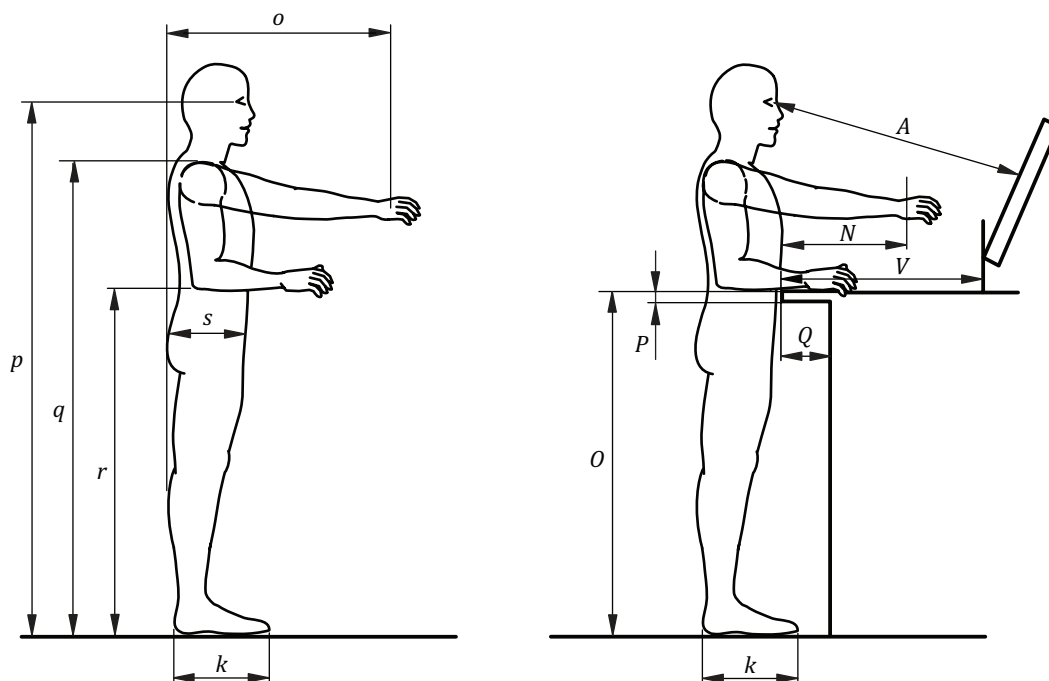

Anthropometric measurements			Control workstation dimensions		
Symbol	Description	ISO 7250-1:2008 subclause	Symbol	Description	Calculation
<i>p</i>	Eye height	4.1.3	<i>A</i>	Viewing distance <sup>a</sup>	
<i>q</i>	Shoulder height	4.1.4	<i>O</i>	Work surface height <sup>b</sup>	$O = r$ plus shoe heel height
<i>r</i>	Elbow height	4.1.5	<i>P</i>	Work surface thickness <sup>c</sup>	
<i>o</i>	Grip reach	4.4.2	<i>Q</i>	Knee and footwell <sup>d</sup>	
<i>s</i>	Body depth, standing	4.1.10	<i>V</i>	Usable work surface depth <sup>e</sup>	
<i>k</i>	Foot length	4.3.7	<i>N</i>	Maximum reach distance <sup>f</sup>	$N = o$ minus $s$
<sup>a</sup>	Function of eye height and task requirements and equipment.				
<sup>b</sup>	Fixed work surface height — use 0,5* (5th percentile $r$ and 95th percentile $r$ ). Adjustable work surface height — 5th percentile $r$ and 95th percentile $r$ .				
<sup>c</sup>	Recommended value not greater than 40mm.				
<sup>d</sup>	Allow 300mm for shod feet and knee flexion.				
<sup>e</sup>	$V$ = derived from task and control equipment requirements.				
<sup>f</sup>	Use shortest $o$ and largest $s$ .				

**Figure 3 — Illustration of key anthropometric and control workstation dimensions associated with standing control workstation in elevation**



## 5.2 Visual tasks

The basic visual tasks are *detection* and *identification* (see [Annex A](#)).

### 5.2.1 General visual considerations

When arranging displays, the following factors and their interrelationships should be taken into account.

- a) Eye heights, which depend on
- anthropometric data of the user population, and
  - the postures (cf. [Figure 3](#) and [Table 2](#)) of the users while accomplishing their tasks (e.g. monitoring, interacting).

The influence of work surface adjustability, i.e. chair height on the eye height, shall be considered. Refer to the appropriate anthropometric data set for input to the calculations.

- b) Viewing distances should be chosen taking full account of
- eye strain,
  - the nearpoint of the eye,
  - the visual angle required to identify the characters on the screen, and
  - the task.

- c) The normal line-of-sight (see [Table 2](#)).

NOTE See [Annex A](#) for guidance on determining the arrangement of control workstation displays.

### 5.2.2 General visual recommendations

Accurate identification of a character depends on its legibility (its contrast, font style, colour, size, etc.), as well as the viewing distance (see [Annex A](#) for further details).

The viewing distance shall be based on the following considerations concerning character height.

- For VDUs (visual display units), the minimum height of monochrome Latin characters shall subtend 15 min of angle (in accordance with ISO 9355-2). Recommended Latin character heights are, however, 18 to 20 min of angle<sup>1</sup>.

For a quick approximation, the following calculation shall be used:

- maximum viewing distance (for rectangular view on the middle of a display area) =  $215 \times$  Latin character's height

NOTE For a detailed calculation of the arrangement of displays, see [Annex A](#).

- Character height is given by the height of capitals and numerals of the smallest font size in use on the screen.
- Viewing distance for identification of characters and symbols shall be  $> 500$  mm, since large groups of users (e.g. older users without spectacles) will have difficulty accommodating their eyes to shorter distances.
- For minimizing eye strain, the viewing distance should be 700 mm or greater (see Bibliography [9]). Larger viewing distances improve depth of focus.

1) Taken from ISO 9241-3:1992, *Ergonomic requirements for office work with visual display terminals (VDTs) — Part 3: Visual display requirements*. Cancelled and replaced by References [15] to [19].

NOTE Typically, control workstations need to accommodate writing areas, keyboards, phones and communication equipment, etc. in front of the display. For this reason, larger viewing distances may be required which would have an impact on, for example, font sizes, display formats.

Assuming a reclined seated position, the normal line-of-sight is straight forward in the horizontal plane and approximately 15° below the horizontal in the vertical plane (see [Table 1](#)). This is the starting point for the following requirements

- Displays (see ISO 11064-3) requiring frequent or critical monitoring (e.g. operator working screens) shall be arranged in front of the operator in the primary display zone. The primary display zone, when the line-of-sight direction is not imposed by external task requirements, is in the vertical plane within an angle of 40° above and below the normal line-of-sight. In the horizontal plane, this range will be approximately 35° left and right of the line-of-sight for monitoring tasks (see ISO 11428) and more if head and body movement are taken into account.
- Where information from off-workstation displays (large screens, wall and mimic panels, etc.) is required for the operator's task, this shall be fully visible from all expected working positions in the control room (see ISO 11064-3).

## 5.3 Auditory tasks

### 5.3.1 General auditory considerations

Control workstations may be equipped with a variety of sound-generating devices. They may be used in alerting operators to normal (e.g. feedback, phone) and abnormal events, providing feedback to keyboard operations, and conveying person-to-person messages. Unlike the visual systems that require direct lines-of-sight to be effective, audible devices, e.g. speakers, bells and buzzers, can be mounted in a variety of locations and still be effective in conveying information to the operator (for guidance on auditory alarms, see ISO 11064-5). The location of the devices is often governed by operating practices, areas of responsibility, shared or dedicated control workstation allocations, etc.

### 5.3.2 General auditory requirements and recommendations

General auditory requirements and recommendations include the following.

- a) Sound-producing devices (e.g. speakers) shall be located and mounted such that their function is not compromised.
- b) Where alarm indications can be provided by other than auditory means, silencing may be permissible. Silencing should be possible from the normal working position of the operator.
- c) It shall be possible to readily associate a particular audible signal with a unique workstation in multiple control workstation configurations.
- d) Use of spatial separation to aid identification when multiple auditory sources are present.
- e) The impact of background noise should be considered when designing auditory alarms (see ISO 11064-6)

## 5.4 Working postures

### 5.4.1 Posture considerations

An operator assumes several postures while accomplishing a task: seated, standing or alternating between seated and standing positions. The design implications of these alternatives on general control workstation arrangements are presented in [Clause 7](#).

As a general principle, seated workstations are appropriate for lengthy periods of operation and standing control workstations for occasional use. Sit/stand control workstations may provide an alternative solution when the duration of the anticipated tasks is taken into account and a standing-only control

workstation is not appropriate. The ergonomic requirements are determined by the nature of the task and operator needs for postural change. As an overall principle, any solution should allow for postural variation. See [Table 1](#).

**Table 1 — Ergonomic requirements for control workstations**

Ergonomic requirements		Type of control workstation
Posture	Duration	
Sit	Continuous	Seated workstation
Sit and stand	Mainly seated with occasional standing	Sit/stand workstation
Sit or stand	Mixture of tasks of variable duration	Adjustable workstation
Stand	Continuous	Stand workstation



Also considered are the postures associated with the seated operating condition. When a seated posture is adopted, this may include *bent forward* (monitoring at a high level of attention), *erect* (typing, operating controls), *reclined* (monitoring) and *relaxed* (monitoring) postures. See [Table 2](#) and [Figure 3](#). [Table 2](#) shows the effect on the operator's eye position as a consequence of varying postures; the actual dimensions to be used shall be derived from the anthropometric data of the intended user population. There are corresponding effects regarding reach envelopes, body clearances, etc.

#### 5.4.2 Posture requirements and recommendations

General posture requirements and recommendations include the following.

- a) The design shall accommodate the different viewing distances and the inclination of the normal line-of-sight for the varying postures.
- b) The leg and feet clearances should accommodate a 120° knee bend and a 10° ankle bend, and the geometric effects of these joint extensions should be considered.
- c) Operator chairs shall be height-adjustable. For details concerning control room operator chair requirements, see ISO 9241-5.
- d) Adequate forearm support should be provided.
- e) The quality of chairs used, and their durability, should take into account that operator chairs are normally used 24 h per day, 7 d per week.
- f) The geometric effects of joint extensions, resulting from the differing postures, need to be considered when clearances for legs and feet are considered.

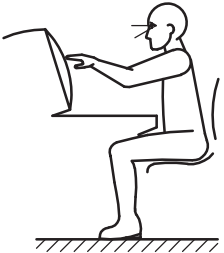
Table 2 — Operations and postures

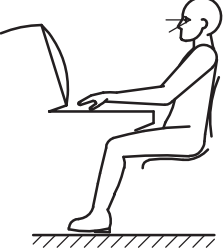
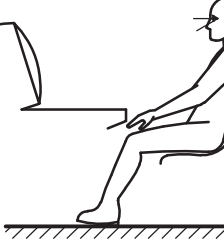
Posture	Normal line-of-sight inclination	Corresponding operations	Remarks
<p>A: Bent forward</p> 	$20^{\circ} \pm 5^{\circ}$	<p>Monitoring at high level of attention</p> <p>Operation of controls</p>	<p>— shoulder joint above edge of console</p> <p>— applicable for short periods of time</p> <p>— max. handreach determined by 5th percentile</p>
<p>B: Erect</p> 	$30^{\circ} \pm 5^{\circ}$	<p>Typing</p> <p>Handwriting</p> <p>Operation of controls</p>	<p>— handreach of the 5th percentile up to 50 cm from edge of console</p> <p>— eyes just above edge of console</p>
<p>C: Reclined</p> 	$15^{\circ} \pm 5^{\circ}$	Monitoring	<p>— eyes up to 18 cm (95th percentile) away from edge of console</p>
<p>D: Relaxed</p> 	$15^{\circ} \pm 5^{\circ}$	<p>Long-term monitoring</p> <p>Talking to others</p>	<p>— eyes up to 35 cm (95th percentile) away from edge of console</p>

## 6 Control workstation layout

Control workstation layout shall take account of the tasks to be carried out at the workstation. In addition to the task analysis, design considerations such as user population, working postures and equipment to be housed will dictate the physical shape and dimensions of the workstation.

It is recommended that the design be planned such that it can accommodate future changes and additional equipment.

## 6.1 General layout considerations

### 6.1.1 Displays

The arrangement of particular task areas and equipment should consider both the horizontal (plan view) and vertical (elevation view) planes. The resulting work space bounded by these horizontal and vertical planes should be located central to the position of the operator. In practice, the operator shall not be required to fixate in one location. The overall design should accommodate the operator's visual, tactile and aural needs in relation to the display, control and communication tasks, as well as consideration for operator's physical postures (sitting, standing, etc.).

Emphasis should be placed on centrally locating those visual displays and indicators that present primary information, the most frequently used displays or those associated with high-priority information such as alarms, overviews and interactive control displays. The method given in [Annex A](#) covers all these aspects in combination. Care should be given to avoid distractions, while at the same time making secondary information accessible in a convenient way.

Viewing angles should be assessed at various vertical and horizontal planes to verify compliance with those recommended in relation to the operator's working position and postures (see [Annex A](#)). The operator should preferably look directly at the centre of the primary information and towards the frequently used ancillary equipment, i.e. pushbutton/switch arrays, security systems, etc.

If the operator is temporarily at a secondary location [i.e. discussion, desk (administrative tasks), printer, etc.], he/she should be able to look back at primary displays.

Control workstations equipped with multiple displays, i.e. typical table top or console mounted VDUs (CRTs, Flat Panel LCDs) and the like, require special attention regarding placement and layout.

The maximum number of displays which can be used at a single control workstation is a major consideration which shall be based on a task analysis. It is generally considered that, from a dedicated operator's working position, and with current technology, not more than four displays (up to 25 inch diagonal) can be satisfactorily monitored and operated. Where monitoring of the general situation is concerned, it may be possible for an additional number of monitors to be viewed, though this would be likely to involve the operator moving away from the front edge of the control console. Where there is a need to monitor and operate more than four displays, a secondary work position may need to be provided alongside the main position. This will ensure acceptable viewing angles relative to shared controlling devices such as keyboards, mice and trackballs. Where the operator has no fixed location, more displays may be placed in a row and acceptable legibility will still be ensured. The cross-section analysis described above may suggest employing a curved or segmented design.

A full range of operational scenarios, e.g. start-up, shut-down, disturbances, outage operation, etc., should be considered when determining the quantity and arrangement of the displays and associated controls.

The selection of display types and quantities has an impact on the control workstation layout. Attributes such as size, weight, heat dissipation and electromagnetic interference/radio frequency interference susceptibility are factors to consider when selecting display technology for a control workstation.

The use of wall-mounted displays and their associated visual requirements are covered in ISO 11064-3. In general, any large wall-mounted or projected display may be used for primary or secondary information and its design and specification should take account of the information presented on associated control workstations as well as any constraints created by the vertical dimensions of these workstations.

### 6.1.2 Controls

A variety of technologies may be incorporated into the control workstation's design to enable an operator to exercise control over the displayed data, input of data and text, or the manipulation of control states, modes, etc. Commonly implemented technologies include fixed and variable function keyboards, touchscreens, mouse, trackballs, voice-actuated controls, light pens and conventional controls. Depending on the specific task requirements and frequency of use, one or more input techniques may be more suitable

than others. Requirements and guidance on the selection and application of various input technologies can be found in ISO 11064-5.

## 6.2 Layout requirements

Plan layout considerations are similar for both seated and standing operators. The key anthropometric and control workstation dimensions are presented in Figure 4. The greater mobility offered from a standing posture may allow for the more remote positioning of secondary displays and controls on a standing only workstation.

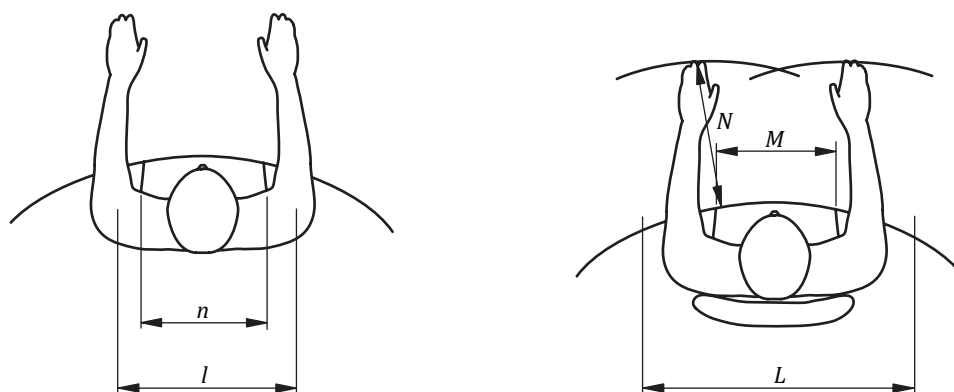

Anthropometric measurements			Control workstation dimensions		
Symbol	Description	ISO 7250-1:2008 subclause ref.	Symbol	Description	Calculation
$l$	Shoulder breadth (biacromial)	4.2.8	$L$	Minimum control workstation width <sup>a</sup>	$L = l$ plus twice $m$ plus comfort factor <sup>d</sup>
$n$	Hip breadth, sitting	4.2.11	$M$	Width clearance <sup>b</sup>	$M = n$ plus comfort or determined by chair dimensions
$o, g$	See Figure 2		$N$	Maximum reach distance <sup>c</sup>	$N = o$ minus $g$
a	Use largest $l$ and largest $m$ .				
b	Use whichever is the greater.				
c	Use shortest $o$ and largest $g$ .				
d	The minimum separation between operators in relation to comfort will depend on social and cultural factors. As a rule of thumb, minimum separations between operators of less than 0,5 m are not recommended.				

**Figure 4 — Illustration of key anthropometric dimensions associated with control workstation in plan**

### 6.2.1 Displays

Display characteristics, including contrast, flicker, jitter, character-font and -size, all contribute to legibility. Apart from legibility, viewing conditions like viewing distance and ambient lighting (see Figure A.1) determine the operator's perception of information. For a first assessment, see 5.2.1. There are several principles for locating displays on control workstations, as follows.

- Table-top displays — it should be possible to tilt and swivel the display screen.
- Built-in displays, which have fixed orientations. When carefully designed in terms of anthropometric data and viewing conditions (see Annex A), this solution may be acceptable.
- The arrangement of the displays should consider operator tasks which may require access while sitting, standing or both.

- Preferably, the user should be able to adjust the control workstation easily to ensure a good working posture.
- In the case of a non-adjustable working height, special attention should be given to the vertical position of the displays. Important factors are eye height, viewing distance, field of vision, cone of fixations and normal line-of-sight. For the combined impact of all these factors, see [Annex A](#).
- [Annex A](#) should be used as an approach to determine the position of single and multiple display screens.

In order to match the *normal line-of-sight* (see [Table 2](#)) when large display screens are employed, it may be necessary to place the screen at a lower level than the work surface.

## 6.2.2 Controls

The following are principles for locating controls on control workstations.

- a) Keyboards should preferably be located in the centre of the operator's usual work space. This may be in front of a single display or centred between two displays, as determined by the task analysis, information allocation, etc.
- b) If movable keyboards are used, sufficient space should be provided to allow swivelling of the keyboard around a vertical axis 30° in a clockwise or anticlockwise direction from normal (60° total).
- c) Other keyboard requirements shall comply with ISO 9241-410, including
  - a keyboard slope of between 0° and 15°,
  - a home row height recommended to be no greater than 30mm and required not to exceed 35mm, and
  - centre line spacing between keys of 19mm ± 1mm.

These requirements relate to full-size keyboards. Where special-purpose keyboards are required, the recommendations for full sized keyboards should be followed where practical.

- d) There shall be a minimum space of 150 mm depth and the width of the keyboard shall be available for supporting the operator's forearms and wrists in front of the keyboard.
- e) The control workstation design shall be "ambidextrous" in relation to the placement of one-handed devices such as a mouse or trackball. There shall be adequate space and cabling facilities to place such devices to the left or right of the user.
- f) Similar ambidextrous requirements shall be considered for *mouse-only* control workstation designs. Other requirements include the following.
  - 1) A space shall be available for placement of a 200 × 240 mm mouse mat. The space shall allow for swivelling of the mouse mat around a vertical axis 30° in a clockwise or anticlockwise direction from normal (60° total).
  - 2) A minimum space of 150 mm depth and the width of the mouse mat shall be available for supporting the operator's forearms and wrists in front of the mouse mat.

Where controls can be moved to suit left or right-handed operation, these controls should be adaptable to right or left-hand use, respectively.

**EXAMPLE** Buttons are reconfigured on the mouse/trackball so that the index finger performs the traditional "right click" functions and the other buttons the lesser functions.

As a practical matter, most left-handed users become quite adept at using right-handed mouse/trackballs. In fact, they are often at an advantage in that they are able to use the mouse and still write with their preferred hand if their task involves both computer input and checking off or writing on paper copy.

A far more serious concern is that left-handed users are apt to forget to change their mouse/trackball configuration back and the next right-handed user may have problems using the input device.

- g) Space for trackball operation shall be provided and comply with the same requirements as for a mouse regarding forearm support and arcs of rotation.
- h) The use of shared devices, i.e. one keyboard, mouse, etc. for multiple display devices, is preferred over dedicated keyboards for each display device. Ideally, the system software should self-select the controlled display as the pointing symbol (cursor) is moved from one display to the other. In some instances, it may be advisable, for safety reasons, to have a dedicated control for each display. In this case, these controls shall be unambiguously related to their associated displays.
- i) Input devices shall not compete for work surface space with other items such as telephones, operating manuals and log books. These items should have their own space as dictated by their physical size, frequency of use, emergency priorities, etc. Other considerations include
  - possible need for task lighting for printed materials,
  - suitable placement of devices within the anticipated reach envelopes, and
  - possible shielding of any light-generating devices to prevent glare or annoying distractions.
- j) Frequently used controls should be within reach of the operator working in an erect work posture and from the expected work locations at the console (see [Figure 3](#)). For engineering purposes, it suffices to use as an approximation the 5th percentile armreach minus 50 mm (grasping compensation).
- k) Frequently used controls shall not be positioned above the 5th percentile shoulder height of the user population.
- l) Input devices (controls, keyboard, mouse, telephone) should preferably be freely moveable over the work surface in front of the displays (ISO 9241-3). They may be built-in if there are special requirements (e.g. vibration, earthquake conditions).
- m) The height of keyboards, mice, trackballs and other input devices should be approximately at or below the elbow height (see ISO 7250) of the seated operator.
- n) In positioning emergency controls, the time allowed for between alarm and activation by the operator shall be taken into account.
- o) Emergency controls shall be protected against accidental activation.

### 6.2.3 Other workstation tasks

A console may have to accommodate task zones for administration, documentation, communication, training on-the-job and/or supervisory tasks. Appropriate consideration should be given to both left- and right-handed users.

Usually, several other types of task zones on workstations are located in a control centre; these may give rise to requirements including space for the layout of drawings, short meetings and coffee breaks.

Should permit handling be required, the precise needs should be established by a task analysis. Where a counter is required, its height shall be based on the elbow height of a standing, small operator (5th percentile).

### 6.2.4 General

Other general requirements and recommendations are as follows.

- The layout of a control workstation shall take into account: access requirements (for maintenance) and cable management. In the case of table-top VDUs, input devices and communication equipment access for maintenance (or instrument exchange) shall always be straightforward. In the case of built-in equipment, easily removable access panels, or free space around the devices, etc. should be considered.



- The requirements for future change, e.g. spare space for additional equipment, modified working practices and task allocations, should be considered.
- Safety and stability of the control workstation (such as the risk of structural failure or excessive heat conductivity of work surfaces) shall be taken into account in accordance with ISO 9241-5.

## 7 Control workstation dimensions

### 7.1 Dimension considerations

The aim of this clause is to give guidance on the dimensioning of control workstations. Emphasis is on designs for seated operators. Many of the same principles, i.e. reach envelopes, viewing angles and distances, etc., apply to all the options of seated only, sit/stand and standing control workstations. This clause does not aim to describe all possible solutions in full detail.

### 7.2 Seated control workstations

For a control workstation for seated postures, the dimensions shown in [Figure 2](#) are significant, including

- vertical, horizontal, and lateral clearance of legs, knees and feet under the work surface, which shall be sufficient for the user with 95th percentile leg length,
- work surface at or slightly below elbow height,
- support for the buttocks and legs and support for the lower back,
- controls within optimum or maximum reach envelopes depending on frequency, priority of use (outcome of the task analysis),
- characters on instruments or displays that shall subtend the required minimum visual angle to the seated control room operator,
- height of the seat pan (a footrest may be necessary in some circumstances),
- a seat height that shall be adjustable.

If the user population is highly variable in size, an adjustable work surface should be considered, e.g. population of males and females together with a mix of users from different countries (see [5.2](#)).

Adjustable furniture can offer the operator options for posture change during the work shift.

NOTE 1 Where height-adjustable workstations are used, the appropriate positioning of other equipment has to be considered in relation to the range of adjustment.

NOTE 2 An adjustable footrest shall be available for the smaller users (down to 5th percentile popliteal height). Footrest dimensions should be as follows:

- minimum surface: (450 × 350) mm (width × depth);
- minimum height at front side 50 mm, height adjustable to at least 110 mm;
- minimum slope 5°, and adjustable to at least 15°.

As many users as possible should be able to rest their feet on the ground (i.e. not be hindered by a small foot rest); the implication of this recommendation is that the thickness of the table surface is minimized, 40 mm being a maximum.

NOTE 3 By minimizing the table surface thickness, giving sufficient leg clearance for tall users, as many as possible of the user population will be able to use the table surface comfortably (i.e. with their elbows on or just above the surface).

### 7.3 Standing control workstations

For the overall dimensions of a standing workstation, the ergonomic considerations applied for seated workstations largely apply. In addition:

- work-top surfaces shall not be higher than the 5th percentile elbow height of the user population;
- for these workstations where 5th percentile elbow height is used it is assumed that this is for intermittent use, but where standing control workstations are to be used for extended periods of time, then adjustability should be provided;
- where a view over the top is required, the maximum vertical dimension of the control workstation should not exceed the 5th percentile standing eye-height of the user population;
- where items need to be passed across the workstation, the horizontal dimensions should take account of the 5th percentile arm reach of the user population;
- adequate clearance should be allowed for the feet when standing at the workstation.

## Annex A (informative)

### Arranging displays and control workstations

#### A.1 Purpose

The purpose of [Annex A](#) is to present examples of the use of a scientifically proven<sup>[2]</sup> tool for determining arrangements of visual displays (monitors) at workstations.

Additional terms and definitions applicable to [Annex A](#) are given in [Table A.1](#).

**Table A.1 — Additional terminology**

Term	Definition	Source
<b>space of identification</b>	space containing all positions relative to a display (a screen or a panel) from which each character on this display can be reliably identified, i.e. is seen under the smallest visual angle for identification, regardless of the viewing direction  See <a href="#">Table A.2</a> .	ISO 11064-4:2004
<b>detection</b>	perceptual process by which a person becomes aware of the mere presence of a signal (stimulus)  See <a href="#">Table A.3</a> .	ISO 11064-4:2004
<b>identification</b>	cognitive process by which a perceived form (symbol, letter etc.) or colour matches one already known by, or simultaneously presented to, the observer  Identification of characters or colours becomes easier if context information exists, e.g. if the character to be identified is part of a word or if (a) reference colour(s) exists, to be compared with the one to be identified. When reading figures from digital displays or tag numbers, no context exists in relation to a single character. Identification's relationship with detection is further clarified in <a href="#">Table A.2</a> .	ISO 11064-4:2004

**Table A.1** (continued)

Term	Definition	Source
<b>visual angle</b>	<p>angle subtended at the eye by the viewed object, e.g. a character or symbol</p> <p>See <a href="#">Figure A.1</a>.</p> <p>The visual angle is a measure to determine identification from a geometric point of view, regardless of the viewing distance (see <a href="#">Figure A.2</a>).</p> <p>According to ISO 9355-2, the character height shall be at least 15 min of angle. (The value is 16 min of angle in ISO 9241-3:1992.)</p>	ISO 11064-4:2004
<b>posture</b>	<p>overall position of the body, or bodily parts, in relation to each other with respect to the workplace and its components</p> <p>To accomplish a specific task (e.g. handwriting), persons take an appropriate posture unconsciously.<sup>[10]</sup></p> <p>In control centres, the following postures have to be taken into account:</p> <p>a) seated postures (see <a href="#">Table 2</a>): 1) bent forward, 2) upright, 3) reclined, 4) relaxed;</p> <p>b) standing.</p> <p>Identification of each character has to be ensured from the seated postures 1) to 3) while 4) or standing is dedicated to monitoring. In the latter case, visual requirements are less demanding (just for “detection”).</p> <p>For this reason, the following concentrates on both postures 1) and 4) (see also <a href="#">Table 2</a>), which are worst case for identification.</p> <p>For a given person, each posture corresponds to a distinct</p> <ul style="list-style-type: none"> <li>— position of the eyes (in the vertical as well as in the horizontal plane),</li> <li>— inclination of the normal line-of-sight,</li> <li>— handreach envelope.</li> </ul>	ISO 9241-5:1998

**Table A.2 — Factors determining dimension of space of identification**

Factor	Space of identification	
	increases	decreases
<b>Visual angle</b>	the smaller the angle	the larger the angle
<b>Displayed characters</b>	the larger the characters	the smaller the characters
<b>Curvature of display surface</b>	if concave	if convex
<b>Display dimension</b>	the smaller the display format	the larger the display format

**Table A.3 — Interrelationship among basic cognitive terms** (read each “Process” line as a complete sentence)

Term	Process <sup>a</sup>			
	Mode	Quality	Object	Location
<b>Detection</b>	Simultaneously becoming aware of		a stimuli	in the visual field.
<b>Identification</b>	Subsequently sweeping the line-of-sight from		one cluster to another	within the cone of fixation.
A cluster may be 4 to 6 letters (characters).				
<sup>a</sup> Read each line as a continuous sentence.				

## A.2 Starting point

The proper arrangement of singular or multiple displays at control workstations depends on several factors:

- a) eye height of the users as influenced by
  - 1) postures (that vary) when accomplishing their jobs at the workstation,
  - 2) body dimensions of the user population;
- b) visual extent of the displayed characters in either direction (not restricted to the orthogonal direction);
- c) frequency of visual scanning, the line-of-sight sweeps from one display to another;
- d) dimensions of the displays.

The following factors are major determinants in the ergonomic arrangement of equipment on the workstation:

- viewing distance;
- display dimensions;
- angulation in terms of tilt and/or swivel;
- display position relative to height and depth of the console;
- hand-reach envelope.

To support the designer in fitting all these aspects together properly, the concept of *space of identification* has proven useful.<sup>[1]</sup> The concept is also applicable for reviewing the arrangement and dimensions of control workstations. See [Table A.1](#).

## A.3 Application of space of identification

The same procedure has to be applied separately for the horizontal and for the vertical plane. Only the procedure for the vertical plane is given here.

The scale of 1:10 is recommended for drawing the templates (easy to calculate, drawing fits on paper format).

### A.3.1 Procedure for a single monitor

**Step 1:** Make a template (elevation drawing) of the working plane of the console (height above the floor and surface depth) applying the selected scale (see [Figure A.3](#)).

**Step 2:** Add the eye-points of the 5th and of the 95th percentile for both bent forward and reclined postures of the user population (see [Figure A.3](#)).

NOTE 1 The postures unconsciously taken by the users during accomplishing a distinct job are shown in [Table 2](#).

NOTE 2 It is sufficient, to consider the extreme postures (i.e. “bent forward” and “reclined”). The corresponding dimensions (for a particular user population) are given in [Table 2](#).

If males and females establish the user population, apply the eye-points of the 5th percentile from the females, but of the 95th from the males.

**Step 3:** Construct the side-view drawing of the space of identification as follows (see [Figure A.4](#)).

- a) Choose the maximum viewing distance  $D_{\max}$ . If identification of characters and/or symbols (excluding video viewing) is the task required to be undertaken, the recommended viewing distance is 70 to 80 cm.<sup>[9]</sup>
- b) Calculate the required minimum character height on the display:

$$h = D_{\max} \frac{\sigma_{\min}}{3439}$$

(see [Figure A.1](#)).

- c) Draw the side view of the screen (or panel) applying the chosen scale.
- d) Draw a circle (diameter  $D_{\max}$ ) touching the topmost visible position.
- e) Draw a circle (diameter  $D_{\max}$ ) touching the lowest visible position.
- f) The overlap of both circles is the resulting side view of the “space of identification”. Its area is limited by the nearpoint. To consider this:
  - 1) draw a line parallel to the display surface equal to the distance of the nearpoint = 50 cm;
  - 2) add the middle axis of the screen (or panel) as an orthogonal line.

**Step 4:** Copy the composite drawing developed in step 3 onto foils (overheads, transparencies, etc.).

NOTE 3 The process has been presented around the use of foils, though computer-based alternatives can equally well be applied.

**Step 5:** Overlay the drawing of the console ([Figure A.3](#)) with the foil(s) ([Figure A.4](#)) to achieve [Figure A.5](#), which is derived by the following.

- Shift and tilt the overlay until all eye-points appear within the space of identification.
- Check if the inclination of the middle axis corresponds to the normal line-of-sight (see values in [Table 2](#)) for the display. Benefits: Promotes relaxed viewing, characters appear largest.
- Check if the complete height of the visible display is located within the cone of fixations. Benefit: The line-of-sight can sweep to all positions on the display without head movement. This is particularly advantageous if the task requires keeping the eyes on display for some time.

**Step 6:** For on-screen controls (light pen, touch screens), superimpose hand-reach envelopes.

NOTE 4 The viewing distance chosen in the example is far greater than can be applied with on-screen controls.

**Step 7:** Apply steps 1 to 6 to the horizontal plane.

### A.3.2 Procedure for multiple monitors

Control workstations found in control centres consist of multiple monitors. The various displays simultaneously present different data and informational views to one operator. Consequently, the user frequently has to change his view from one display (screen) to another.

The arrangement of the various displays can be optimized in order to facilitate visual accommodation, symbol identification and overall effectiveness by applying the space of identification principle as used in the single monitor case. In the multiple-screen situation, the monitors should be arranged as follows.

- Adjacent screens should be close together. This is for “motion economy” and minimizes space requirements.
- The viewing distance(s) to any of the frequently viewed displays should be as equal as possible.
- The line-of-sight should be orthogonal to each display.

The appropriate arrangement is easily found by applying the space of identification. Again, the considerations are made in the vertical and in the horizontal plane.

If, occasionally, more than one operator has to work at such a control workstation, it should be possible to swivel the monitors.

#### A.3.2.1 Stacked screens

To find out the proper height, distance and tilt-angles of stacked screens, proceed as follows (the example in [Figure A.6](#) is based on two screens):

**Steps 1 to 6:** Complete steps 1 to 6 as outlined for a single monitor, then carry out the following additional steps.

##### Step 7a:

- 1) use the elevation (side) view of the console ([Figure A.3](#)) as a base;
- 2) overlay two foils (output of step 4) in a manner such that both elevation-(side-) viewed displays become stacked;
- 3) shift and tilt the foils until the eye-points appear within the overlapping “spaces of identification” (see [Figure A.6](#)).

Check that

- the displays are located as low as possible,
- the viewing distances to the displays are similar, or
- the upper display(s) provide information which does not require long-term observations (e.g. overviews).

**Step 8a:** Apply steps 1 to 7 to the horizontal plane.

#### A.3.2.2 Side-by-side screens

**Steps 1 to 7:** Apply steps 1 to 7 as outlined for the single monitor for the top view.

**Step 7b:** Proceed with the top view corresponding to the procedure applied for the side view (see step 7a).

As an example, [Figure A.7](#) illustrates the result for the arrangement of three frequently viewed screens at a control workstation.

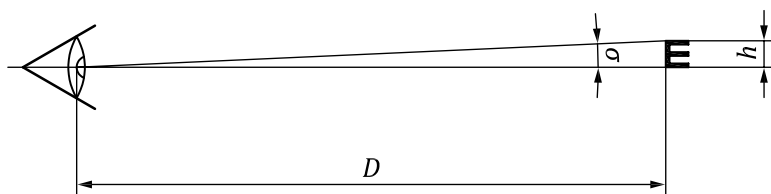

Subject	Viewing conditions	Object
<b>Visual acuity</b> up to 50 % below normal value <b>Adaptation</b> currently not optimal	<b>Illumination</b> level beyond optimum, <b>glare</b>	<b>Reduced</b> contrast, <b>blurred</b> characters, non-homogeneous character and/or underground <b>luminance</b> , character <b>height</b> lower than those of capital letters
The minimum visual angle of 15 min is not valid for — coloured characters, or — vibrations of object and/or subject (e.g. in transportation).		

**Key**

$D$  viewing distance at orthogonal view

$h$  character height

$\sigma$  visual angle

NOTE For eyes of normal acuity, for optimal viewing conditions and best display quality, a visual angle of a few minutes would be sufficient, even for characters like E or B. These Latin characters demand highest visual resolution due to their utmost details in vertical section. The same is true for M and W in horizontal section. According to ISO 9355-2 for achromatic characters, the minimum value of the visual angle shall be 15 min. This value takes account of the fact that, in reality, the following features are typically less than optimum.

**Figure A.1 — Features determining the definition of the minimum visual angle**

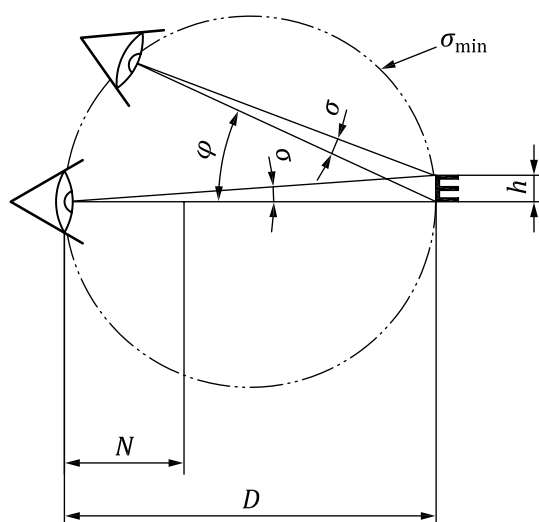

**Key**

$N$  nearpoint

$D$  maximum viewing distance at orthogonal view

$h$  character height

$\varphi$  angle of view

$\sigma$  visual angle

$\sigma_{\min}$  minimum visual angle (on the circle)

**Figure A.2 — Interrelationship between viewing distance, visual angle and angle of view**



The visual angle is the most relevant geometric dimension to be verified, if character height is sufficient to ensure identification.

At a constant visual angle, the maximum viewing distance is obtained from orthogonal view on the character. In practice, characters seldom are seen orthogonally. At a constant visual angle, the viewing distance decreases with an increase of the angle of view. The positions from which the character is seen at a constant visual angle are along a circle-line touching the character. Its diameter is equal to the orthogonal viewing distance  $D$ .

If the minimum visual angle is applied, the circle captures all positions from where the character can be seen under a visual angle that extends the required minimum.

A restricted area of possible eye-points within the circle comes from the characteristics of the human eye. It is capable of accommodating only to distances further than the nearpoint. It is recommended to apply the nearpoint of persons 45 years old (approximately 50 cm). Reason: Most older users wear corrective spectacles.

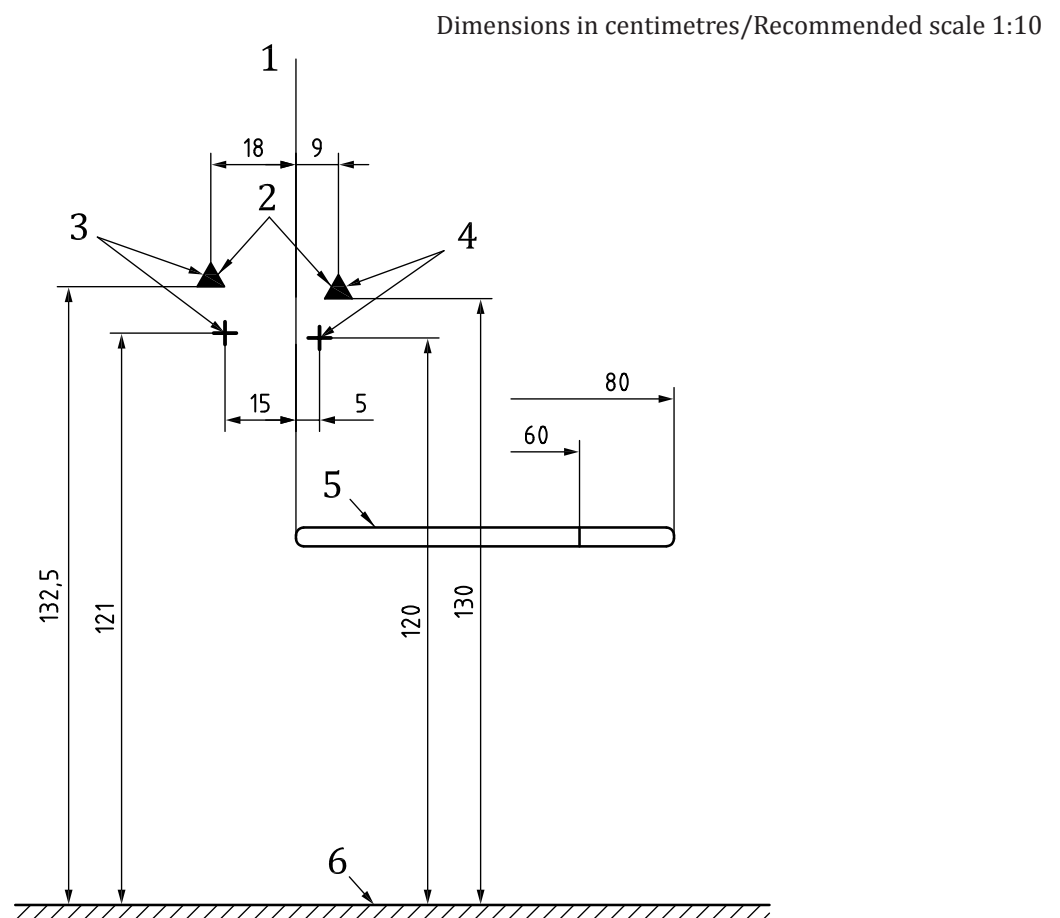

**Key**

- |   |   |   |  |
|---|---|---|--|
| 1 | edge of the console                       | 5 | console surface  |
| 2 | edge positions at seated postures 3 and 4 | 6 | floor  |
| 3 | posture "reclined"                        | ▲ | eye-point of the 95th percentile dimensions (see <a href="#">Table 2</a> ) |
| 4 | posture "bent forward"                    | + | eye-point of the 5th percentile (see <a href="#">Table 2</a> )             |

**Figure A.3 — Template (example) — Console with eye-points — Elevation view**

Recommended scale 1:10

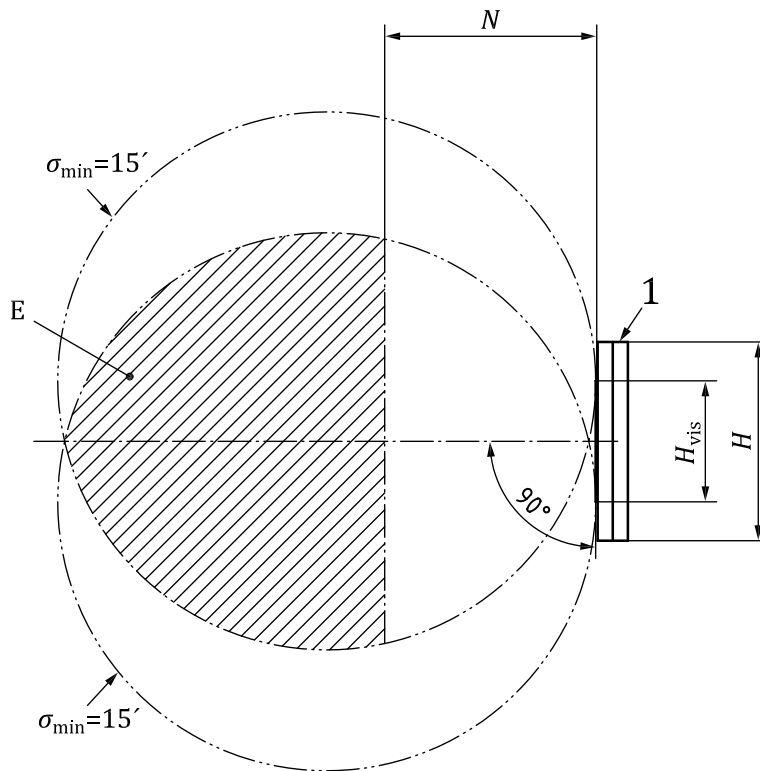

**Key**

- 1 flat panel display 20 inch diagonal
- E space of identification
- H<sub>vis</sub> visible height = 32,4 cm
- H height of housing = 44 cm
- h character height = 0,5 cm
- N nearpoint = 50 cm
- σ<sub>min</sub> minimum visual angle (on the circles) = 15 minutes of arc

**Figure A.4 — Template (example) — Space of identification — Elevation view, true of scale**

Dimensions in centimetres/Recommended scale 1:10

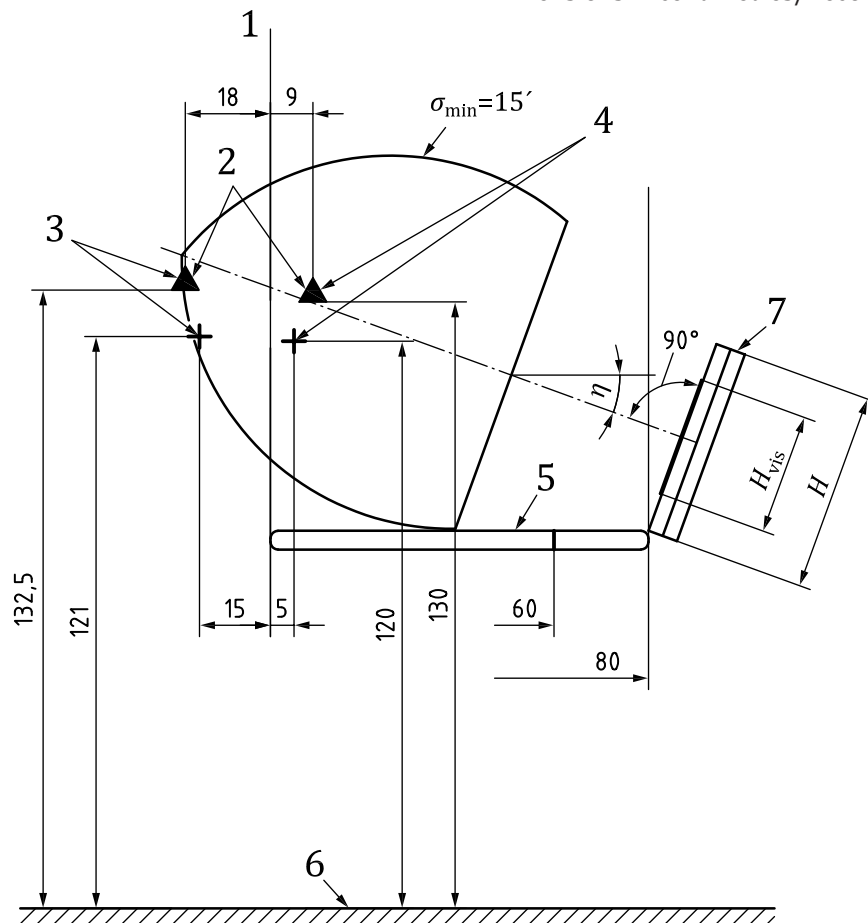

**Key**

- |   |                                       |                |  |
|---|---------------------------------------|----------------|--|
| 1 | edge of the console                   | $H_{vis}$      | visible height = 32,4 cm   |
| 2 | eye-points at seated postures 3 and 4 | $H$            | height of housing = 44 cm  |
| 3 | eye-points at posture "reclined"      | $h$            | character height = 0,5 cm  |
| 4 | eye-points at posture "bent forward"  | $\sigma_{min}$ | minimum visual angle = 15 minutes  |
| 5 | console surface                       | $\eta$         | inclination corresponds to those of the "normal line-of-sight"             |
| 6 | floor                                 | ▲              | eye-point of the 95th percentile dimensions (see <a href="#">Table 2</a> ) |
| 7 | flat panel display 20 inch diagonal   | +              | eye-point of the 5th percentile (see <a href="#">Table 2</a> )             |

**Figure A.5 — Template (example) — Applied space of identification — Elevation view**

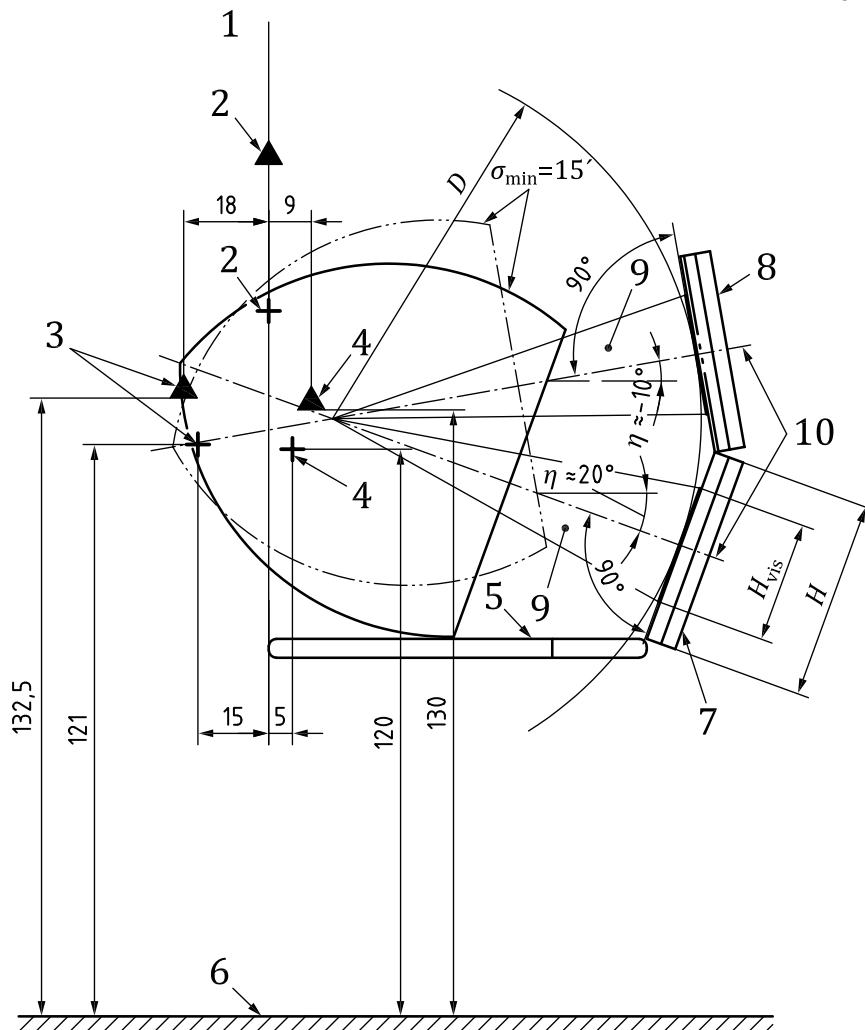

**Key**

- |           |  |                |   |
|-----------|--|----------------|---|
| 1         | edge of the console  | 6              | floor   |
| 2         | eye-points at posture "standing"   | 7              | flat panel 20 inch diagonal   |
| 3         | eye-points at posture "reclined"   | 8              | flat panel display 20 inch to be occasionally viewed (e.g. overview display)                                      |
| 4         | eye-points at posture "bent forward"   | 9              | optimal cones of fixations (i.e. allows fixation of any position just by eye movement, no head movement required) |
| 5         | console surface  | 10             | head movement required when changing the view from the lower screen to the upper (or vice versa)                  |
| $D$       | viewing distance, identical for both screens (i.e. no accommodation required)                    | $H$            | height of housing = 44 cm   |
| $H_{vis}$ | visible height = 32,4 cm   | $h$            | character height = 0,5 cm   |
| $\eta$    | inclination (the inclination of lower screen corresponds to those of the "normal line-of-sight") | $\sigma_{min}$ | minimum visual angle = 15 min   |
| ▲         | eye-point of the 95th percentile dimensions (see Table 2)  | +              | eye-point of the 5th percentile (see Table 2)   |

NOTE For viewing the upper screen, the head has to be raised slightly. In order to avoid continuous contraction of the neck muscles, viewing of this screen should be required only occasionally.

**Figure A.6 — Example applying space of identification to design stacking of screens appropriately**

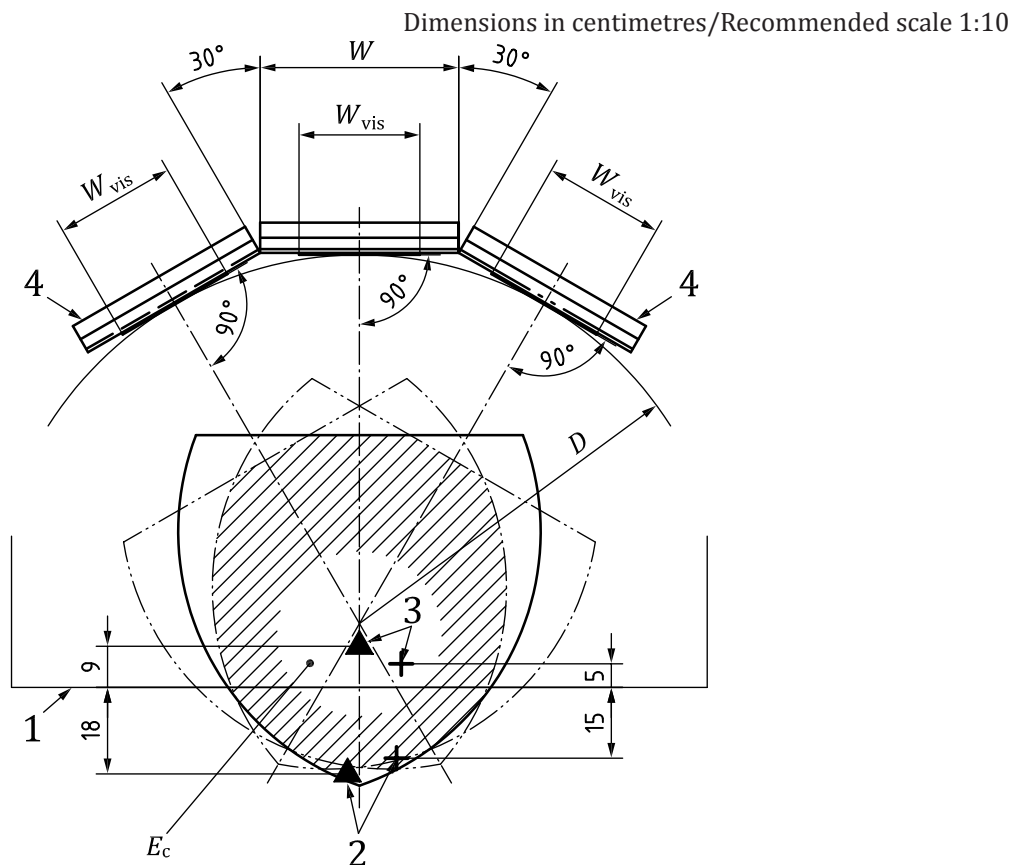

**Key**

- |  |  |
|--|--|
| 1 edge of the console  | $E_c$ common space of identification to all three screens                            |
| 2 eye positions at seated posture “reclined”                                 | $W_{vis}$ visible width = 40,2 cm  |
| 3 eye positions at seated posture “bent forward”                             | $W$ width of housing = 50 cm   |
| 4 flat panel displays 20 inch diagonal                                       | $h$ character height = 0,5 cm  |
| ▲ eye-point of the 95th percentile dimensions (see <a href="#">Table 2</a> ) | $D$ identical viewing distance to all three screens (i.e. no accommodation required) |
| + eye-point of the 5th percentile (see <a href="#">Table 2</a> )             |  |

NOTE The common space of identification to all three screens gets largest by swivelling them approximately 30°. In doing so, a very constant viewing distance is obtained and also orthogonal view to the centre of each screen.

**Figure A.7 — Example (plan view) for applying space of identification to arrange screens in horizontal plane**

## Annex B (informative)

### Conformance matrix

#### B.1 Purpose

The purpose of [Annex B](#) is to present a sample procedure for assessing applicability and conformance.

The checklist can be used to determine whether the applicable recommendations in this part of ISO 11064 have been met. The checklist includes all the requirements and recommendations from this part of ISO 11064 presented in sequence.

It should be noted that the procedure described is provided as guidance and is not an exhaustive process to be used as a substitute for the standard itself. The use of the checklist provides a basis for:

- determining which of the recommendations are applicable,
- determining whether applicable recommendations have been adhered to, and
- providing a systematic listing of all the applicable recommendations that have been followed

The completed checklist can be used in support of statements relating to conformance with this part of ISO 11064. This checklist may be applied to both existing installations, for auditing purposes, or proposals for new control workstations.

#### B.2 How to use the table

Clause/subclause numbers and titles are presented in the first two columns of the table. The third column is used to indicate whether the recommendation in each clause is applicable or not applicable.

The applicability of all the recommendations should be checked and Y and N entered in column three as appropriate. Where a recommendation is not applicable a brief note giving the reasons should be inserted in column five.

There should be an entry in column four, showing whether each applicable recommendation has been satisfied (Yes), partially satisfied (Partially) or not satisfied (No). Any clause which is judged to be partially satisfied, or not satisfied should be accompanied by a brief note explaining the reasons why this is the case. The following are provided as examples.

[Tables B.1](#) and [B.2](#) show examples of how to complete the conformance matrix checklist, [Table B.3](#), when a requirement is not applicable to the design or is applicable but not met.

**Table B.1 — Example — Requirement not applicable to design**

Subclause/provision of this part of ISO 11064-4:2013		Applicable Y/N	Compliant Y/P/N	Comment
5.1.2	Has the design and layout of the control workstation taken account of multiple users operating a single workstation?	N		The workstation is only intended for a single user.

**Table B.2 — Example — Requirement applicable but not met**

Subclause/provision of this part of ISO 11064-4:2013		Applicable Y/N	Compliant Y/P/N	Comments
5.1.2	Has appropriate consideration been given to the effects of footwear, clothing and personal protective equipment?	Y	N	The workstation does not provide adequate clearance to accommodate personal protective equipment.
6.2.2	Do full-sized keyboards comply with ISO 9241-410?	Y	N	Multiple full-size keyboard cannot be accommodated on the available worktop space.

**Table B.3 — Conformance matrix**

Subclause/provision of this part of ISO 11064-4:2013		Applicable Y/N	Compliant Y/P/N	Comments
5.1.1 <sup>a</sup>	Has the control workstation design used 5th to 95th percentile dimensions of the intended user population?			
5.1.1 <sup>a</sup>	Has the control workstation design considered all human capabilities, limitations and needs?			
5.1.2 <sup>a</sup>	Have appropriate consideration been given to the effects of footwear, clothing and personal protective equipment?			
5.1.2 <sup>a</sup>	Have the effects of posture variation been considered in the control workstation design?			
5.1.2 <sup>a</sup>	Has the use of an adjustable control workstation been considered where 5th to 95th percentile anthropometric requirements cannot be met?			
5.1.2 <sup>b</sup>	Does the design endeavour to accommodate users presenting extreme anthropometric dimensions?			
5.1.2 <sup>b</sup>	Have the controls on a vertical panel been positioned such that a standing taller user must not stoop to operate them?			
5.1.2 <sup>b</sup>	Has caution be exercised where anthropometric data has been combined?			
5.1.2 <sup>b</sup>	Have realistic operating postures been taken into account when applying standard anthropometric data in addition to those presented in <a href="#">Table 2</a> ?			
Y Yes P Partially N No <sup>a</sup> Requirement (“shall”). <sup>b</sup> Recommendation (“should”)				



Table B.3 (continued)

Subclause/provision of this part of ISO 11064-4:2013		Applicable Y/N	Compliant Y/P/N	Comments
5.1.2 <sup>b</sup>	Has the design and layout of the control workstation taken account of multiple users operating a single workstation?			
5.1.2 <sup>b</sup>	Where adjustable workstations have been selected do they aim to accommodate at least 5th to 95th percentile of the determining body dimensions?			
5.1.2 <sup>b</sup>	Are control workstation adjustments easy and safe to use from a seated position?			
5.2.1 <sup>a</sup>	Has the impact of adjustable chairs been considered in relation to seated eye-height?			
5.2.1 <sup>b</sup>	Has the arrangement of displays taken account of postures and anthropometric data?			
5.2.1 <sup>b</sup>	Have the appropriate factors been taken into account when considering viewing distances?			
5.2.2 <sup>a</sup>	Have viewing distances taken account of character heights used on displays?			
5.2.2 <sup>a</sup>	Has the allocation of information between primary and secondary displays been based on frequency of use and priorities?			
5.2.2 <sup>a</sup>	Where shared information is presented on off-workstation displays, and required to be seen by all operators, have suitable locations been specified?			
5.2.2 <sup>b</sup>	Have viewing distances and eye-strain been fully taken into account?			
<p>Y Yes  P Partially  N No  a Requirement ("shall").  b Recommendation ("should")</p>				

**Table B.3** (continued)

Subclause/provision of this part of ISO 11064-4:2013		Applicable Y/N	Compliant Y/P/N	Comments
5.3.2 <sup>a</sup>	Have suitable positions been found for sound producing devices? (e.g. speakers)			
5.3.2 <sup>a</sup>	Has appropriate consideration been given where alarm signals need to be associated with specific workstations?			
5.3.2 <sup>b</sup>	Can the operator silence alarms from their normal working positions?			
5.3.2 <sup>b</sup>	Has background noise been taken into account when designing auditory alarms?			
5.4.1 <sup>b</sup>	Have postural variations been allowed for?			
5.4.2 <sup>a</sup>	Are all operator chairs height-adjustable?			
5.4.2 <sup>b</sup>	Have relaxed leg positions been taken into account?			
5.4.2 <sup>b</sup>	Has account been taken of the 24/7 use of chairs?			
6 <sup>a</sup>	Does the control workstation layout support all operator and maintenance tasks to be carried out?			
6.1.1 <sup>a</sup>	In the design of the control workstation layout has an appropriate task analysis been carried out?			
6.1.1 <sup>a</sup>	Does the arrangement of displays on the control workstation prevent the operator fixating on one location?			
6.1.1 <sup>b</sup>	Have both horizontal and vertical planes been taken into account in the arrangement of displays, priorities and normal operating positions?			
Y Yes P Partially N No <sup>a</sup> Requirement ("shall"). <sup>b</sup> Recommendation ("should")				

Table B.3 (continued)

Subclause/provision of this part of ISO 11064-4:2013		Applicable Y/N	Compliant Y/P/N	Comments
6.1.1 <sup>b</sup>	Has a full range of operational scenarios been considered when determining provision and arrangement of displays?			
6.1.1 <sup>b</sup>	Has the distribution of information between wall-mounted, off-workstation displays and workstation-based displays been considered?			
6.2.1 <sup>b</sup>	For the arrangement of display screens have such factors as adjustability, operator tasks, and anthropometry been taken into account?			
6.2.2 <sup>a</sup>	Do full-sized keyboards comply with ISO 9241-410?			
6.2.2 <sup>a</sup>	Has adequate provision been made for supporting the operator's forearms and wrists in front of input devices?			
6.2.2 <sup>a</sup>	Have the requirements for both left and right-handed users been considered?			
6.2.2 <sup>a</sup>	Has adequate space been provided where mouse mats, or trackballs, are to be used?			
6.2.2 <sup>a</sup>	Where multiple dedicated input devices are used have these been unambiguously allocated to their associated displays?			
6.2.2 <sup>a</sup>	Are all frequently used controls located such that they are easily reached by 5th percentile dimensions of the user population?			
6.2.2 <sup>a</sup>	Have all emergency controls been protected against accidental activation?			
Y Yes P Partially N No a Requirement ("shall"). b Recommendation ("should")				

**Table B.3** (continued)

<b>Subclause/provision of this part of ISO 11064-4:2013</b>		<b>Applicable Y/N</b>	<b>Compliant Y/P/N</b>	<b>Comments</b>
6.2.2 <sup>b</sup>	Has the layout of input devices taken account of factors such as reach distances, frequency of use, physical size and right and left-handed operators?			
6.2.4 <sup>a</sup>	Have safety considerations been taken into account?			
6.2.4 <sup>b</sup>	Has maintenance access been considered in the design?			
6.2.4 <sup>b</sup>	Have any requirements for future change been considered?			
7.1 <sup>a</sup>	Have anthropometric considerations been applied to all workstations?			
7.2 <sup>a</sup>	Do all characters subtend the required minimum visual angles in relation to operator tasks and viewing positions?			
7.2 <sup>a</sup>	Have adjustable footrests been made available if required?			
7.3 <sup>b</sup>	Have appropriate anthropometric measurements been taken into account for standing control workstations?			
Y Yes P Partially N No a Requirement ("shall"). b Recommendation ("should")				

## Bibliography

- [1] CHARWAT H. J. Arrangement of monitors in control rooms; *Proceedings of Man-Machine Systems, Analysis, Design and Evaluation*, Oulu, Finland 1988
- [2] GEISER G. Viewing geometry of single or multiple screen displays with planar or curved surface; *INTERACT Proceedings*, 1987, pages 772–776
- [3] PHEASANT S. *Bodyspace, Anthropometry, Ergonomics and the Design of Work*. Taylor & Francis, London, 1997
- [4] PIKAAR R.N. et al. *Workplace layout. Ergonomics in Process Control Rooms; Part 2: Design Guideline*, page 39–51. International Instrument Users' Association WIB, The Hague 1998
- [5] VDI/VDE 3546-5, 1991, *Design of Process Control Rooms. Arrangement of monitors at operator stations*
- [6] JÜRGENS H.W., AUNE I.A., PIEPER U. *International data on anthropometry*. ILO, Geneva, 1990
- [7] ISO 7250-1:2008, *Basic human body measurements for technological design — Part 1: Body measurement definitions and landmarks*
- [8] ISO 14738:2002, *Safety of machinery — Anthropometric requirements for the design of workstations at machinery*
- [9] JASCHINSKI-KRUZA W. Beanspruchung bei der Bildschirmarbeit: Die Belastung der Augenmuskulatur bei verschiedenen Sehabständen. *VDI-Fortschrittsbericht*, Reihe 17, Nr. 44, Düsseldorf 1988
- [10] BUBB H., & KAIN V. Untersuchung über die realitätsbezogene Handhabung von Zeichenschablonen der menschlichen Gestalt. *Zeitschrift für Arbeitswissenschaft* **40** (1986) 2, pages 97–107
- [11] ISO 6385:2004, *Ergonomic principles in the design of work systems*
- [12] ISO 8995:1989, *Principles of visual ergonomics — The lighting of indoor work systems*
- [13] EN 614-1:2006, *Safety of machinery — Ergonomic design principles — Part 1: Terminology and general principles*
- [14] ISO 9355-2:1999, *Ergonomic requirements for the design of displays and control actuators — Part 2: Displays*
- [15] ISO 9241-302:2008, *Ergonomics of human-system interaction — Part 302: Terminology for electronic visual displays*
- [16] ISO 9241-303:2011, *Ergonomics of human-system interaction — Part 303: Requirements for electronic visual displays*
- [17] ISO 9241-304:2008, *Ergonomics of human-system interaction — Part 304: User performance test methods for electronic visual displays*
- [18] ISO 9241-305:2008, *Ergonomics of human-system interaction — Part 305: Optical laboratory test methods for electronic visual displays*
- [19] ISO 9241-307:2008, *Ergonomics of human-system interaction — Part 307: Analysis and compliance test methods for electronic visual displays*
- [20] ISO 11064-2:2000, *Ergonomic design of control centres — Part 2: Principles for the arrangement of control suites*
- [21] ISO 11064-6:2005, *Ergonomic design of control centres — Part 6: Environmental requirements for control centres*





# British Standards Institution (BSI)

BSI is the national body responsible for preparing British Standards and other standards-related publications, information and services.

BSI is incorporated by Royal Charter. British Standards and other standardization products are published by BSI Standards Limited.

## About us

We bring together business, industry, government, consumers, innovators and others to shape their combined experience and expertise into standards-based solutions.

The knowledge embodied in our standards has been carefully assembled in a dependable format and refined through our open consultation process. Organizations of all sizes and across all sectors choose standards to help them achieve their goals.

## Information on standards

We can provide you with the knowledge that your organization needs to succeed. Find out more about British Standards by visiting our website at [bsigroup.com/standards](http://bsigroup.com/standards) or contacting our Customer Services team or Knowledge Centre.

## Buying standards

You can buy and download PDF versions of BSI publications, including British and adopted European and international standards, through our website at [bsigroup.com/shop](http://bsigroup.com/shop), where hard copies can also be purchased.

If you need international and foreign standards from other Standards Development Organizations, hard copies can be ordered from our Customer Services team.

## Subscriptions

Our range of subscription services are designed to make using standards easier for you. For further information on our subscription products go to [bsigroup.com/subscriptions](http://bsigroup.com/subscriptions).

With **British Standards Online (BSOL)** you'll have instant access to over 55,000 British and adopted European and international standards from your desktop. It's available 24/7 and is refreshed daily so you'll always be up to date.

You can keep in touch with standards developments and receive substantial discounts on the purchase price of standards, both in single copy and subscription format, by becoming a **BSI Subscribing Member**.

**PLUS** is an updating service exclusive to BSI Subscribing Members. You will automatically receive the latest hard copy of your standards when they're revised or replaced.

To find out more about becoming a BSI Subscribing Member and the benefits of membership, please visit [bsigroup.com/shop](http://bsigroup.com/shop).

With a **Multi-User Network Licence (MUNL)** you are able to host standards publications on your intranet. Licences can cover as few or as many users as you wish. With updates supplied as soon as they're available, you can be sure your documentation is current. For further information, email [bsmusales@bsigroup.com](mailto:bsmusales@bsigroup.com).

## BSI Group Headquarters

389 Chiswick High Road London W4 4AL UK

## Revisions

Our British Standards and other publications are updated by amendment or revision.

We continually improve the quality of our products and services to benefit your business. If you find an inaccuracy or ambiguity within a British Standard or other BSI publication please inform the Knowledge Centre.

## Copyright

All the data, software and documentation set out in all British Standards and other BSI publications are the property of and copyrighted by BSI, or some person or entity that owns copyright in the information used (such as the international standardization bodies) and has formally licensed such information to BSI for commercial publication and use. Except as permitted under the Copyright, Designs and Patents Act 1988 no extract may be reproduced, stored in a retrieval system or transmitted in any form or by any means – electronic, photocopying, recording or otherwise – without prior written permission from BSI. Details and advice can be obtained from the Copyright & Licensing Department.

## Useful Contacts:

### Customer Services

**Tel:** +44 845 086 9001

**Email (orders):** [orders@bsigroup.com](mailto:orders@bsigroup.com)

**Email (enquiries):** [cservices@bsigroup.com](mailto:cservices@bsigroup.com)

### Subscriptions

**Tel:** +44 845 086 9001

**Email:** [subscriptions@bsigroup.com](mailto:subscriptions@bsigroup.com)

### Knowledge Centre

**Tel:** +44 20 8996 7004

**Email:** [knowledgecentre@bsigroup.com](mailto:knowledgecentre@bsigroup.com)

### Copyright & Licensing

**Tel:** +44 20 8996 7070

**Email:** [copyright@bsigroup.com](mailto:copyright@bsigroup.com)



...making excellence a habit.™