

BS EN ISO 10579:2013



BSI Standards Publication

**Geometrical product
specifications (GPS) —
Dimensioning and tolerancing
— Non-rigid parts**

bsi.

...making excellence a habit.™

National foreword

This British Standard is the UK implementation of EN ISO 10579:2013. It is identical to ISO 10579:2010. It supersedes BS ISO 10579:2010, which is withdrawn.

The UK participation in its preparation was entrusted to Technical Committee TDW/4, Technical Product Realization.

A list of organizations represented on this committee can be obtained on request to its secretary.

This publication does not purport to include all the necessary provisions of a contract. Users are responsible for its correct application.

© The British Standards Institution 2013.
Published by BSI Standards Limited 2013

ISBN 978 0 580 81091 6

ICS 01.100.20

Compliance with a British Standard cannot confer immunity from legal obligations.

This British Standard was published under the authority of the Standards Policy and Strategy Committee on 31 July 2010.

Amendments/corrigenda issued since publication

Date	Text affected
30 September 2013	This corrigendum renumbers BS ISO 10579:2010 as BS EN ISO 10579:2013

ICS 01.100.20

English Version

Geometrical product specifications (GPS) - Dimensioning and tolerancing - Non-rigid parts (ISO 10579:2010 including Cor 1:2011)

Spécification géométrique des produits (GPS) - Cotation et tolérancement - Pièces non rigides (ISO 10579:2010, Cor 1:2011 inclus)

Geometrische Produktspezifikation (GPS) - Bemaßung und Tolerierung - Nicht-formstabile Teile (ISO 10579:2010 + Cor 1:2011)

This European Standard was approved by CEN on 11 July 2013.

CEN members are bound to comply with the CEN/CENELEC Internal Regulations which stipulate the conditions for giving this European Standard the status of a national standard without any alteration. Up-to-date lists and bibliographical references concerning such national standards may be obtained on application to the CEN-CENELEC Management Centre or to any CEN member.

This European Standard exists in three official versions (English, French, German). A version in any other language made by translation under the responsibility of a CEN member into its own language and notified to the CEN-CENELEC Management Centre has the same status as the official versions.

CEN members are the national standards bodies of Austria, Belgium, Bulgaria, Croatia, Cyprus, Czech Republic, Denmark, Estonia, Finland, Former Yugoslav Republic of Macedonia, France, Germany, Greece, Hungary, Iceland, Ireland, Italy, Latvia, Lithuania, Luxembourg, Malta, Netherlands, Norway, Poland, Portugal, Romania, Slovakia, Slovenia, Spain, Sweden, Switzerland, Turkey and United Kingdom.



EUROPEAN COMMITTEE FOR STANDARDIZATION
COMITÉ EUROPÉEN DE NORMALISATION
EUROPÄISCHES KOMITEE FÜR NORMUNG

Management Centre: Avenue Marnix 17, B-1000 Brussels

Foreword

The text of ISO 10579:2010 including Cor 1:2011 has been prepared by Technical Committee ISO/TC 213 “Dimensional and geometrical product specifications and verification” of the International Organization for Standardization (ISO) and has been taken over as EN ISO 10579:2013 by Technical Committee CEN/TC 290 “Dimensional and geometrical product specification and verification” the secretariat of which is held by AFNOR.

This European Standard shall be given the status of a national standard, either by publication of an identical text or by endorsement, at the latest by January 2014, and conflicting national standards shall be withdrawn at the latest by January 2014.

Attention is drawn to the possibility that some of the elements of this document may be the subject of patent rights. CEN [and/or CENELEC] shall not be held responsible for identifying any or all such patent rights.

According to the CEN-CENELEC Internal Regulations, the national standards organizations of the following countries are bound to implement this European Standard: Austria, Belgium, Bulgaria, Croatia, Cyprus, Czech Republic, Denmark, Estonia, Finland, Former Yugoslav Republic of Macedonia, France, Germany, Greece, Hungary, Iceland, Ireland, Italy, Latvia, Lithuania, Luxembourg, Malta, Netherlands, Norway, Poland, Portugal, Romania, Slovakia, Slovenia, Spain, Sweden, Switzerland, Turkey and the United Kingdom.

Endorsement notice

The text of ISO 10579:2010 including Cor 1:2011 has been approved by CEN as a EN ISO 10579:2013 without any modification.

Introduction

This International Standard is a geometrical product specification (GPS) standard and is to be regarded as a global GPS standard (see ISO/TR 14638)^[4]. It influences chain links 1, 2 and 3 of the chain of standards on form of line independent of datum, form of line dependent on datum, form of surface independent of datum, form of surface dependent on datum, orientation, location, circular run-out and total run-out in the general GPS matrix.

For more detailed information on the relation of this standard to other standards and the GPS matrix model, see Annex B.

Certain parts, when removed from their manufacturing environment, may deform significantly from their defined limits owing to their weight, flexibility or the release of internal stresses resulting from the manufacturing processes.

These parts are defined as “non-rigid parts” and the deformation is acceptable provided that the parts may be brought within the indicated tolerance by applying reasonable force to facilitate inspection and assembly.

Depending on the design function and the part's interface with its mating components, instead of, or in addition to, assessing the part conventionally (in its free state condition), it may be necessary to assess the part when subject to restraint that is no greater than those accepted in the assembled condition.

Parts in this category include both those of inherently rigid material (such as thin metal parts) and those of inherently flexible material (such as rubber, plastics, etc.).

Geometrical product specifications (GPS) — Dimensioning and tolerancing — Non-rigid parts

1 Scope

This International Standard gives rules for dimensioning and tolerancing non-rigid parts where restraining of features is required during verification of dimensions and tolerances specified on a drawing.

2 Normative references

The following referenced documents are indispensable for the application of this document. For dated references, only the edition cited applies. For undated references, the latest edition of the referenced document (including any amendments) applies.

ISO 1101:2004, *Geometrical Product Specifications (GPS) — Geometrical tolerancing — Tolerances of form, orientation, location and run-out*

3 Terms and definitions

For the purposes of this document, the following terms and definitions apply.

3.1

non-rigid part

part which deforms to an extent that in the free state is beyond the dimensional and/or geometrical tolerances on the drawing

3.2

free state

condition of a part subjected only to the force of gravity

4 Basic principles

The distortion of a non-rigid part must not exceed that which allows the part to be brought within specified tolerances for verification and positioning at assembly, or assembled, by applying pressure or forces not exceeding those which can be expected under normal assembly conditions. It is impossible to avoid the effect of natural forces such as gravity, but the extent of distortion may depend upon the orientation of the part and condition of the part in the free state. If it is necessary to indicate the tolerance in the free state, the conditions under which the tolerance is to be achieved (i.e. the direction of gravity, conditions in which it is to be supported, etc.) may have to be indicated in a note, as shown in Annex A. For non-rigid parts, identified on the drawing by the added statement “ISO 10579-NR”, the restrained condition applies unless the dimensions and tolerances are qualified by the symbol $\text{\textcircled{F}}$, see Clause 5.

5 Indications on drawings

Drawings of non-rigid parts shall include the following indications as appropriate (see also Annex A):

- a) in or near the title block, the indication "ISO 10579-NR";
- b) in a note, the conditions under which the part shall be restrained to meet the drawing requirements;
- c) geometrical tolerances allowed in the free state, with the modifying symbol \textcircled{F} included in the tolerance frame in accordance with ISO 1101;
- d) dimensional tolerances allowed in the free state, with the modifying symbol \textcircled{F} after the dimensional tolerance;
- e) the conditions under which the geometrical tolerance under free state is achieved, such as direction of gravity, orientation of the part, etc.

Annex A (informative)

Examples of indication and interpretation

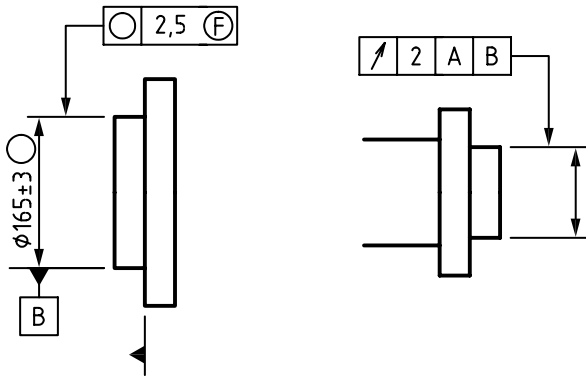
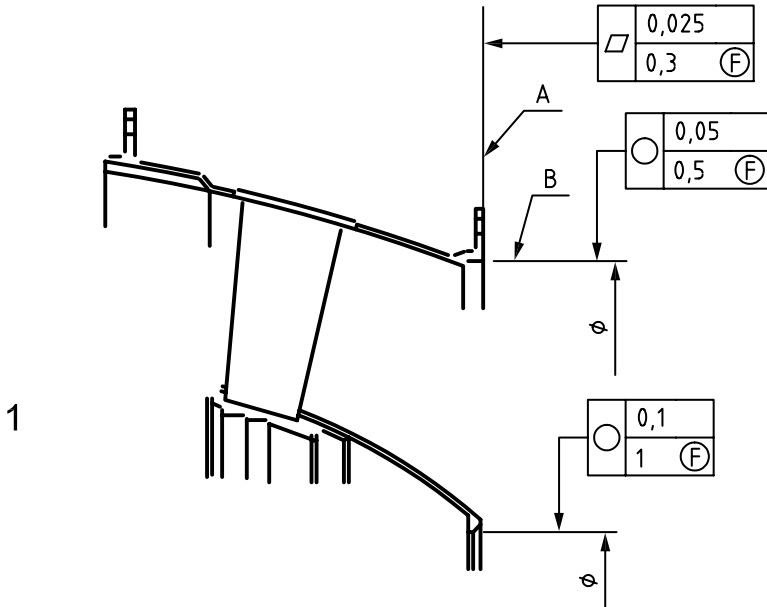
Indication on the drawing	Interpretation
 <p>ISO 10579-NR</p> <p>Restrained condition: The surface indicated as datum A is mounted (with 64 bolts M6 tightened to a torque of 9 N·m to 15 N·m) and the feature indicated as datum B is restrained at the corresponding mating size.</p>	<p>The geometrical and dimensional tolerance, followed by the symbol \textcircled{F}, shall be ensured in the free state. Other tolerances apply under the conditions indicated in the note.</p>
Indication on the drawing	Interpretation
 <p>ISO 10579-NR</p> <p>Key</p> <p>1 direction of gravity</p> <p>Restrained condition: The surface indicated as surface A is mounted (with 120 bolts M20 tightened to a torque of 18 N·m to 20 N·m) and the feature indicated as surface B is restrained at the corresponding mating size.</p>	<p>The geometrical tolerance, followed by the symbol \textcircled{F}, shall be ensured in the free state. Other tolerances apply under the conditions indicated in the note.</p>

Annex B (informative)

Relation to the GPS matrix model

B.1 General

For full details about the GPS matrix model, see ISO/TR 14638^[4].

B.2 Information about this standard and its use

This International Standard gives rules for dimensioning and tolerancing non-rigid parts where restraining of features is required during verification of dimensions and tolerances specified on a drawing.

B.3 Position in the GPS matrix model

This International Standard is a geometrical product specification (GPS) standard and is to be regarded as a global GPS standard (see ISO/TR 14638). It influences chain links 1, 2 and 3 of the chain of standards on form of line independent of datum, form of line dependent on datum, form of surface independent of datum, form of surface dependent on datum, orientation, location, circular run-out and total run-out in the general GPS matrix, as graphically illustrated in Figure B.1.

Global GPS standards							
Fundamental GPS standards	General GPS standards						
	Chain link number	1	2	3	4	5	6
	Size						
	Distance						
	Radius						
	Angle						
	Form of line independent of datum	X	X	X			
	Form of line dependent on datum	X	X	X			
	Form of surface independent of datum	X	X	X			
	Form of surface dependent on datum	X	X	X			
	Orientation	X	X	X			
	Location	X	X	X			
	Circular run-out	X	X	X			
	Total run-out	X	X	X			
	Datums						
	Roughness profile						
	Waviness profile						
Primary profile							
Surface imperfections							
Edges							

Figure B.1 — Position in the GPS matrix model

B.4 Related standards

The related standards are those of the chains of standards indicated in Figure B.1.

Bibliography

- [1] ISO 2692:2006, *Geometrical product specifications (GPS) — Geometrical tolerancing — Maximum material requirement (MMR), least material requirement (LMR) and reciprocity requirement (RPR)*
- [2] ISO 5458:1998, *Geometrical Product Specifications (GPS) — Geometrical tolerancing — Positional tolerancing*
- [3] ISO 5459:1981, *Geometrical product specifications (GPS) — Geometrical tolerancing — Datums and datum-systems*
- [4] ISO/TR 14638, *Geometrical product specification (GPS) — Masterplan*

British Standards Institution (BSI)

BSI is the national body responsible for preparing British Standards and other standards-related publications, information and services.

BSI is incorporated by Royal Charter. British Standards and other standardization products are published by BSI Standards Limited.

About us

We bring together business, industry, government, consumers, innovators and others to shape their combined experience and expertise into standards-based solutions.

The knowledge embodied in our standards has been carefully assembled in a dependable format and refined through our open consultation process. Organizations of all sizes and across all sectors choose standards to help them achieve their goals.

Information on standards

We can provide you with the knowledge that your organization needs to succeed. Find out more about British Standards by visiting our website at bsigroup.com/standards or contacting our Customer Services team or Knowledge Centre.

Buying standards

You can buy and download PDF versions of BSI publications, including British and adopted European and international standards, through our website at bsigroup.com/shop, where hard copies can also be purchased.

If you need international and foreign standards from other Standards Development Organizations, hard copies can be ordered from our Customer Services team.

Subscriptions

Our range of subscription services are designed to make using standards easier for you. For further information on our subscription products go to bsigroup.com/subscriptions.

With **British Standards Online (BSOL)** you'll have instant access to over 55,000 British and adopted European and international standards from your desktop. It's available 24/7 and is refreshed daily so you'll always be up to date.

You can keep in touch with standards developments and receive substantial discounts on the purchase price of standards, both in single copy and subscription format, by becoming a **BSI Subscribing Member**.

PLUS is an updating service exclusive to BSI Subscribing Members. You will automatically receive the latest hard copy of your standards when they're revised or replaced.

To find out more about becoming a BSI Subscribing Member and the benefits of membership, please visit bsigroup.com/shop.

With a **Multi-User Network Licence (MUNL)** you are able to host standards publications on your intranet. Licences can cover as few or as many users as you wish. With updates supplied as soon as they're available, you can be sure your documentation is current. For further information, email bsmusales@bsigroup.com.

Revisions

Our British Standards and other publications are updated by amendment or revision.

We continually improve the quality of our products and services to benefit your business. If you find an inaccuracy or ambiguity within a British Standard or other BSI publication please inform the Knowledge Centre.

Copyright

All the data, software and documentation set out in all British Standards and other BSI publications are the property of and copyrighted by BSI, or some person or entity that owns copyright in the information used (such as the international standardization bodies) and has formally licensed such information to BSI for commercial publication and use. Except as permitted under the Copyright, Designs and Patents Act 1988 no extract may be reproduced, stored in a retrieval system or transmitted in any form or by any means – electronic, photocopying, recording or otherwise – without prior written permission from BSI. Details and advice can be obtained from the Copyright & Licensing Department.

Useful Contacts:

Customer Services

Tel: +44 845 086 9001

Email (orders): orders@bsigroup.com

Email (enquiries): cservices@bsigroup.com

Subscriptions

Tel: +44 845 086 9001

Email: subscriptions@bsigroup.com

Knowledge Centre

Tel: +44 20 8996 7004

Email: knowledgecentre@bsigroup.com

Copyright & Licensing

Tel: +44 20 8996 7070

Email: copyright@bsigroup.com

BSI Group Headquarters

389 Chiswick High Road London W4 4AL UK



...making excellence a habit.™