

Dentistry — Polymer-based crown and bridge materials

The European Standard EN ISO 10477:2004 has the status of a
British Standard

ICS 11.060.10

National foreword

This British Standard is the official English language version of EN ISO 10477:2004. It is identical with ISO 10477:2004. It supersedes BS EN ISO 10477:1996 which is withdrawn.

The UK participation in its preparation was entrusted by Technical Committee CH/106, Dentistry, to Subcommittee CH/106/2, Prosthodontic materials, which has the responsibility to:

- aid enquirers to understand the text;
- present to the responsible international/European committee any enquiries on the interpretation, or proposals for change, and keep the UK interests informed;
- monitor related international and European developments and promulgate them in the UK.

A list of organizations represented on this subcommittee can be obtained on request to its secretary.

Cross-references

The British Standards which implement international or European publications referred to in this document may be found in the *BSI Catalogue* under the section entitled “International Standards Correspondence Index”, or by using the “Search” facility of the *BSI Electronic Catalogue* or of British Standards Online.

This publication does not purport to include all the necessary provisions of a contract. Users are responsible for its correct application.

Compliance with a British Standard does not of itself confer immunity from legal obligations.

Summary of pages

This document comprises a front cover, an inside front cover, the EN ISO title page, the EN ISO foreword page, the ISO title page, pages ii to v, a blank page, pages 1 to 21 and a back cover.

The BSI copyright notice displayed in this document indicates when the document was last issued.

Amendments issued since publication

Amd. No.	Date	Comments

This British Standard was published under the authority of the Standards Policy and Strategy Committee on 13 October 2004

© BSI 13 October 2004

ISBN 0 580 44589 5

English version

**Dentistry - Polymer-based crown and bridge materials (ISO
10477:2004)**

Art dentaire - Produits à base de polymères pour
couronnes et ponts (ISO 10477:2004)

Zahnheilkunde - Kronen- und Brückenkunststoffe (ISO
10477:2004)

This European Standard was approved by CEN on 10 September 2004.

CEN members are bound to comply with the CEN/CENELEC Internal Regulations which stipulate the conditions for giving this European Standard the status of a national standard without any alteration. Up-to-date lists and bibliographical references concerning such national standards may be obtained on application to the Central Secretariat or to any CEN member.

This European Standard exists in three official versions (English, French, German). A version in any other language made by translation under the responsibility of a CEN member into its own language and notified to the Central Secretariat has the same status as the official versions.

CEN members are the national standards bodies of Austria, Belgium, Cyprus, Czech Republic, Denmark, Estonia, Finland, France, Germany, Greece, Hungary, Iceland, Ireland, Italy, Latvia, Lithuania, Luxembourg, Malta, Netherlands, Norway, Poland, Portugal, Slovakia, Slovenia, Spain, Sweden, Switzerland and United Kingdom.



EUROPEAN COMMITTEE FOR STANDARDIZATION
COMITÉ EUROPÉEN DE NORMALISATION
EUROPÄISCHES KOMITEE FÜR NORMUNG

Management Centre: rue de Stassart, 36 B-1050 Brussels

Foreword

This document (EN ISO 10477:2004) has been prepared by Technical Committee ISO/TC 106 "Dentistry" in collaboration with Technical Committee CEN/TC 55 "Dentistry", the secretariat of which is held by DIN.

This European Standard shall be given the status of a national standard, either by publication of an identical text or by endorsement, at the latest by April 2005, and conflicting national standards shall be withdrawn at the latest by April 2005.

This document supersedes EN ISO 10477:1996.

According to the CEN/CENELEC Internal Regulations, the national standards organizations of the following countries are bound to implement this European Standard: Austria, Belgium, Cyprus, Czech Republic, Denmark, Estonia, Finland, France, Germany, Greece, Hungary, Iceland, Ireland, Italy, Latvia, Lithuania, Luxembourg, Malta, Netherlands, Norway, Poland, Portugal, Slovakia, Slovenia, Spain, Sweden, Switzerland and United Kingdom.

Endorsement notice

The text of ISO 10477:2004 has been approved by CEN as EN ISO 10477:2004 without any modifications.

INTERNATIONAL
STANDARD

ISO
10477

Second edition
2004-10-01

**Dentistry — Polymer-based crown and
bridge materials**

Art dentaire — Produits à base de polymères pour couronnes et ponts



Reference number
ISO 10477:2004(E)

Contents

Page

Foreword	iv
Introduction	v
1 Scope	1
2 Normative references	1
3 Terms and definitions	1
4 Classification	2
5 Requirements	2
5.1 Biocompatibility	2
5.2 Sensitivity to ambient light, Type 2, Class 2 polymer-based crown and bridge materials	2
5.3 Depth of cure, Type 2, Class 2 polymer-based crown and bridge materials	3
5.4 Surface finish	3
5.5 Flexural strength	3
5.6 Bond strength	4
5.7 Water sorption	4
5.8 Solubility	4
5.9 Shade consistency	4
5.10 Colour stability	4
6 Sampling	4
6.1 For all tests	4
6.2 For test of shade consistency	4
6.3 For test of colour stability	5
7 Test methods	5
7.1 General	5
7.2 Visual inspection	5
7.3 Sensitivity to ambient light, Type 2, Class 2 polymer-based crown and bridge materials	5
7.4 Depth of cure, Type 2, Class 2 polymer-based crown and bridge materials	7
7.5 Surface finish	7
7.6 Flexural strength	8
7.7 Bond strength	11
7.8 Water sorption and solubility	13
7.9 Shade consistency and colour stability	16
8 Packaging and labelling	17
8.2 Labelling	18
9 Manufacturer's instructions and information for the user	19
9.1 Instructions for use	19
9.2 Shade guide	20
Bibliography	21

Foreword

ISO (the International Organization for Standardization) is a worldwide federation of national standards bodies (ISO member bodies). The work of preparing International Standards is normally carried out through ISO technical committees. Each member body interested in a subject for which a technical committee has been established has the right to be represented on that committee. International organizations, governmental and non-governmental, in liaison with ISO, also take part in the work. ISO collaborates closely with the International Electrotechnical Commission (IEC) on all matters of electrotechnical standardization.

International Standards are drafted in accordance with the rules given in the ISO/IEC Directives, Part 2.

The main task of technical committees is to prepare International Standards. Draft International Standards adopted by the technical committees are circulated to the member bodies for voting. Publication as an International Standard requires approval by at least 75 % of the member bodies casting a vote.

Attention is drawn to the possibility that some of the elements of this document may be the subject of patent rights. ISO shall not be held responsible for identifying any or all such patent rights.

ISO 10477 was prepared by Technical Committee ISO/TC 106, *Dentistry*, Subcommittee SC 2, *Prosthetic materials*.

This second edition cancels and replaces the first edition (ISO 10477:1992), which has been technically revised. It also incorporates the amendment ISO 10477:1992/Amd.1:1998.

The following changes were made:

- a) addition of a bonding test;
- b) addition of a table for the test protocol and two tables of results.

Introduction

Specific qualitative and quantitative requirements for freedom from biological hazards are not included in this International Standard. Assessment of possible biological hazards is covered in ISO 10993-1 and ISO 7405.

Dentistry — Polymer-based crown and bridge materials

1 Scope

This International Standard classifies polymer-based dental crown and bridge materials and specifies their requirements. It also specifies the test methods to be used to determine compliance with these requirements.

This International Standard is applicable to polymer-based dental crown and bridge materials for laboratory-fabricated permanent facings or anterior crowns that may or may not be attached to a metal substructure. It also applies to polymer-based dental crown and bridge materials for which the manufacturer claims adhesion to the metal substructure without macromechanical retention such as beads or wires.

This International Standard is not applicable to polymer-based materials that are used to make crowns, veneers or repairs in the operatory, nor does it cover the application of those materials to stress-bearing areas of posterior teeth.

2 Normative references

The following referenced documents are indispensable for the application of this document. For dated references, only the edition cited applies. For undated references, the latest edition of the referenced document (including any amendments) applies.

ISO 1562, *Dentistry — Casting gold alloys*

ISO 3696:1987, *Water for analytical laboratory use — Specification and test methods*

ISO 6344-1, *Coated abrasives — Grain size analysis — Part 1: Grain size distribution test*

ISO 6507-1, *Metallic materials — Vickers hardness test — Part 1: Test method*

ISO 7491, *Dental materials — Determination of colour stability*

ISO 8601, *Data elements and interchange formats — Information interchange — Representation of dates and times*

ISO 8891, *Dental casting alloys with noble metal content of at least 25 % but less than 75 %*

3 Terms and definitions

For the purposes of this document, the following terms and definitions apply.

3.1

polymer-based crown and bridge material

composition of powders and liquids or pastes that may contain monomers, inorganic and/or polymeric fillers and that, when polymerized, is suitable for its intended use as permanent dental facings or anterior crowns

NOTE Polymerization is effected by mixing initiator(s) and activator(s) (“self-curing” materials) and/or by external energy activation [by heat (“heat-curing” materials), photoactivated materials, by visible light (“light-curing” materials) and/or by UV radiation].

3.2 dentine resin
pigmented and slightly translucent polymer-based crown and bridge material that simulates the natural appearance of dentine

3.3 enamel resin
translucent and slightly pigmented polymer-based crown and bridge material that is packed in a layer over the dentine resin and that simulates the natural appearance of enamel

3.4 cervical resin
intensely pigmented and slightly translucent polymer-based crown and bridge material with a colour that simulates the natural appearance of dentine of the cervical region of the tooth

3.5 opaque resin
intensely pigmented polymer-based crown and bridge material for masking the underlying metal substructure

4 Classification

The polymer-based crown and bridge materials described in this International Standard shall be classified according to their activation system for polymerization.

- **Type 1** polymer-based crown and bridge materials whose setting is effected by mixing initiator(s) and activator(s) (“self-curing” materials);
- **Type 2** polymer-based crown and bridge materials whose setting is effected by the application of energy from an external source (“external-energy-activated” materials), such as heat and/or light or UV radiation;
 - **Class 1** polymer-based crown and bridge materials that do not contain a light or UV-sensitive initiator;
 - **Class 2** polymer-based crown and bridge materials that contain a light or UV-sensitive initiator;
- **Type 3** polymer-based crown and bridge materials whose setting is effected by mixing initiator(s) and activator(s) and also by the application of energy from an external source (“dual-cure” materials).

5 Requirements

5.1 Biocompatibility

See the Introduction for guidance on biocompatibility.

5.2 Sensitivity to ambient light, Type 2, Class 2 polymer-based crown and bridge materials

The polymer-based crown and bridge materials Type 2, Class 2 shall remain physically homogeneous when exposed to ambient light (see Table 1).

Testing shall be carried out in accordance with 7.3.

NOTE For Type 1, Type 2, Class 1 and Type 3 materials, no requirement is specified.

Table 1 — Test protocol

Subclause	Property	Type 1	Type 2		Type 3
			Class 1	Class 2	
5.2	Sensitivity to ambient light	—	—	+	—
5.3	Depth of cure	—	—	+ ^a	—
5.4, 5.5	Surface finish, flexural strength	+ ^a	+ ^a	+ ^a	+ ^a
5.6	Bond strength	+	+	+	+
5.7 to 5.10	Water sorption, solubility, shade consistency, colour stability	+ ^a	+ ^a	+ ^a	+ ^a
+ carry out test; — do not test. ^a If the material is opaque resin, do not test.					

5.3 Depth of cure, Type 2, Class 2 polymer-based crown and bridge materials

For Type 2, Class 2 polymer-based crown and bridge materials, the hardness of the bottom surface shall be not less than 70 % of that of the top surface.

This requirement is not applicable to opaque resins (see Table 1).

Testing shall be carried out in accordance with 7.4.

NOTE For Type 1, Type 2, Class 1 and Type 3 no requirement is specified.

5.4 Surface finish

A test specimen polished in accordance with 7.5 shall have a glossy surface.

This requirement is not applicable to opaque resins (see Table 1).

Testing shall be carried out in accordance with 7.5.

5.5 Flexural strength

The flexural strength shall be at least 50 MPa (see Table 2).

This requirement is not applicable to opaque resins (see Table 1).

Testing shall be carried out in accordance with 7.6.

Table 2 — Physical and chemical requirements

Subclause	Property	Requirement
5.5	Flexural strength	≥ 50 MPa
5.6.1	Bond strength	≥ 5 MPa
5.6.2		≥ 80 % of the value claimed
5.7	Water sorption	≤ 40 $\mu\text{g}/\text{mm}^3$
5.8	Solubility	$\leq 7,5$ $\mu\text{g}/\text{mm}^3$

5.6 Bond strength

5.6.1 If the manufacturer recommends a special metal-bonding system without macromechanical retention, the strength of bond to the metal used for the substructure shall be not less than 5 MPa (see Tables 1 and 2).

Testing shall be carried out in accordance with 7.7.

5.6.2 If the manufacturer claims a value higher than 5 MPa for the bond strength, then the bond strength shall be not less than 80 % of the value claimed.

Testing shall be carried out in accordance with 7.7.

5.7 Water sorption

The water sorption of the cured polymer-based crown and bridge material shall be not more than 40 µg/mm³ (see Table 2).

This requirement is not applicable to opaque resins (see Table 1).

Testing shall be carried out in accordance with 7.8.

5.8 Solubility

The solubility in water of the cured polymer-based crown and bridge material shall be not more than 7,5 µg/mm³ (see Table 2).

This requirement is not applicable to opaque resins (see Table 1).

Testing shall be carried out in accordance with 7.8.

5.9 Shade consistency

The colours of the cured polymer-based crown and bridge material from different batches shall show no more than a slight difference.

This requirement is not applicable to opaque resins (see Table 1).

Testing shall be carried out in accordance with 7.9 and ISO 7491.

5.10 Colour stability

The polymer-based crown and bridge material shall show no more than a slight change in colour.

This requirement is not applicable to opaque resins (see Table 1).

Testing shall be carried out in accordance with 7.9 and ISO 7491.

6 Sampling

6.1 For all tests

The test sample shall consist of one or more retail packages prepared for retail sale of one randomly selected shade from a single batch and contain sufficient (approximately 20 ml) material to carry out the specified tests, plus an allowance for any necessary repetition of tests.

6.2 For test of shade consistency

The sample for the test of shade consistency (5.9 and 7.9) shall consist of the same shade as in 6.1 but of another batch (approximately 1 ml).

6.3 For test of colour stability

The sample for the test of colour stability (5.10 and 7.9) shall consist of two further randomly selected shades. The whole sample shall represent one shade of enamel, dentine and cervical resin (approximately 1 ml each).

7 Test methods

7.1 General

7.1.1 Test conditions

Test specimens shall be prepared and tested at (23 ± 2) °C. The relative humidity shall be not less than 30 %.

7.1.2 Water

Unless otherwise specified, the water to be used shall conform to ISO 3696:1987, Grade 3.

7.1.3 Preparation of test specimens

For the preparation of Types 2 and 3 polymer-based crown and bridge materials, reference should be made to the manufacturer's instructions [see 9.1 p) and q)] that state the external energy source or sources recommended for the materials to be tested. Care shall be taken to ensure that the source is in a satisfactory condition.

Mix or otherwise prepare the polymer-based crown and bridge material in accordance with the manufacturer's instructions and the test conditions specified in 7.1.1.

Use only the quantity required to prepare one of the corresponding specimens.

If fully cured specimens are required for testing (7.5 to 7.9), it is important to ensure that the specimens are homogeneous after removal from the mould. There should be no voids, clefts or air inclusions present by visual inspection without magnification.

NOTE A separating medium which does not interfere with the setting reaction (e.g. 3 % solution of polyvinylstearyl ether wax in hexane) may be used to facilitate removal of the specimen.

7.2 Visual inspection

Use visual inspection to determine compliance with Clauses 8 and 9. The colour comparison in 7.9 shall be performed in accordance with ISO 7491.

7.3 Sensitivity to ambient light, Type 2, Class 2 polymer-based crown and bridge materials

7.3.1 Apparatus

7.3.1.1 Xenon lamp, or radiation source of equivalent performance (a suitable apparatus is described in ISO 7491) with colour-conversion filter ¹⁾ inserted.

The colour-conversion filter shall be hardened glass of thickness 3 mm and shall have an internal transmittance that matches within ± 10 % that shown in Figure 1.

7.3.1.2 Two glass microscope slides/plates.

7.3.1.3 Illuminance-measuring device, e.g. luxmeter, capable of measuring illuminance of $(8\ 000 \pm 1\ 000)$ lx.

7.3.1.4 Adjustable table.

1) The KR 12 filter supplied by Schott Spezialglas GmbH, Vertrieb Filter, Hüttenstr. 1; D-31073 Grünenplan, Germany, is an example of a suitable product available commercially. This information is given for the convenience of users of this International Standard and does not constitute an endorsement by ISO of this product.

7.3.1.5 Matt black cover for the luxmeter cell

NOTE This is intended to prevent reflections from the cell interfering with the observation of the specimen.

7.3.1.6 Timer, accurate to 1 s.

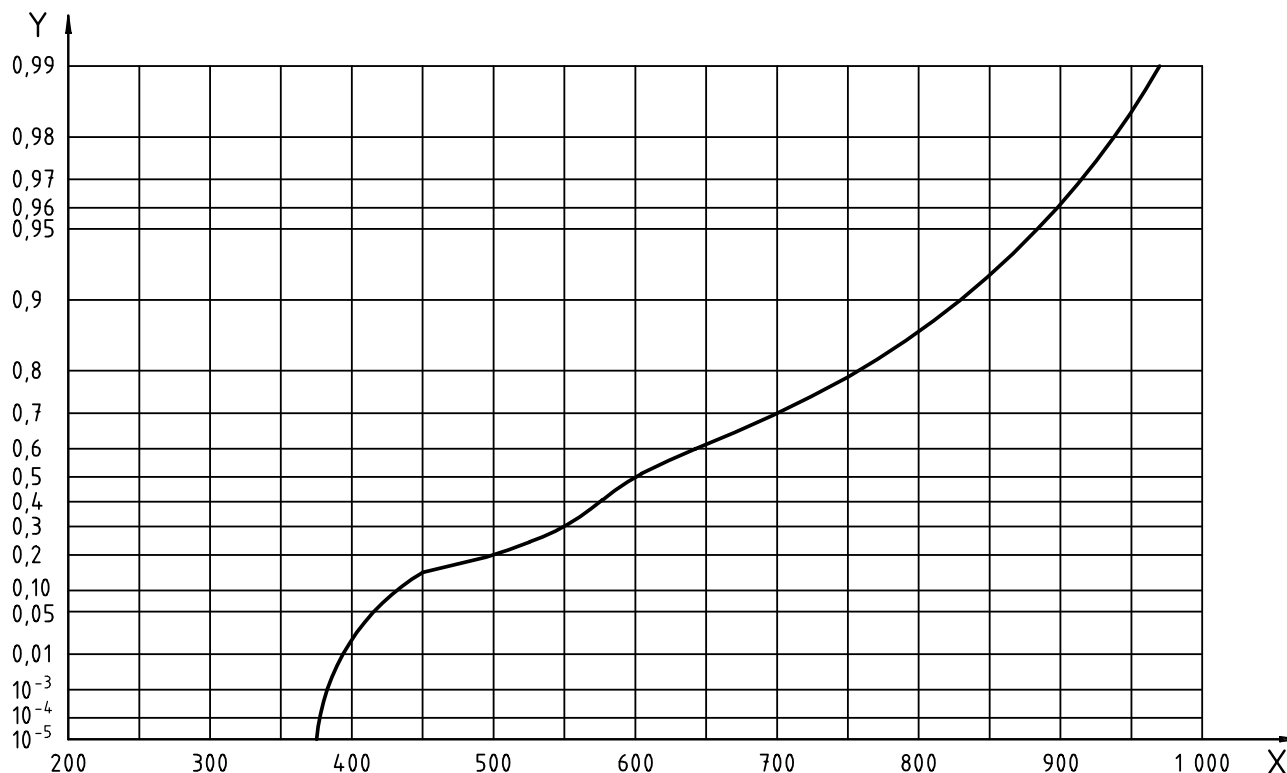

Key

- X wavelength, nm
- Y internal transmittance

Figure 1 — Internal transmittance for colour-conversion filter (7.3.1.1)

7.3.2 Procedure

In a dark room, position the illuminance-measuring device cell (7.3.1.3) under the xenon lamp with the colour conversion filter inserted (7.3.1.1) at such a height as to provide an illuminance of $(8\ 000 \pm 1\ 000)$ lx. [The adjustable table (7.3 1.4) is required to do this efficiently.] Cover the cell with the matt black cover (7.3.1.5). Place a spheroidal mass of approximately 30 mg of polymer-based crown and bridge material onto a glass microscope slide (7.3.1.2), position the slide on top of the cell and expose it to the light for (60 ± 5) s. Remove the slide with the sample from the irradiated area and immediately press the second microscope slide against the polymer-based crown and bridge material with a shearing action to produce a thin layer.

Visually inspect the polymer-based crown and bridge material to see whether it is physically homogeneous.

NOTE During this test, if the polymer-based crown and bridge material has begun to set, clefs and voids will appear in the specimen when the thin layer is being produced. It may aid the inspection to compare the test specimen with one that has been produced in the absence of light.

Repeat the entire procedure twice, using a new sample of polymer-based crown and bridge material for each test.

7.3.3 Expression of results

Record the result of all three tests.

If, on visual inspection, the polymer-based crown and bridge material of all three samples remains physically homogeneous, the polymer-based crown and bridge material complies with the requirement of 5.2. Otherwise the polymer-based crown and bridge material does not comply with the requirement of 5.2.

7.4 Depth of cure, Type 2, Class 2 polymer-based crown and bridge materials

7.4.1 Apparatus

7.4.1.1 Split rings, such as shown in Figure 2, (15 ± 1) mm in diameter and ($1 \pm 0,1$) mm high.

7.4.1.2 Transparent glass plate, measuring approximately 20 mm × 20 mm × 5 mm.

7.4.1.3 Polished metal plate, measuring approximately 20 mm × 20 mm × 5 mm.

7.4.1.4 Radiation source, as recommended by the manufacturer.

7.4.1.5 Hardness testing instrument, for HV 0,5.

7.4.2 Materials

7.4.2.1 White filter paper.

7.4.2.2 Colourless, clear, transparent polyester film, (50 ± 30) µm thick.

7.4.3 Procedure

Cover the polished metal plate (7.4.1.3) with a piece of white filter paper (7.4.2.1) followed by the polyester film (7.4.2.2), and position the split ring (7.4.1.1) upon it. Prepare the polymer-based crown and bridge material according to the manufacturer's instructions, and place it into the split ring to a slight excess. Cover the polymer-based crown and bridge material and the split ring with a second piece of polyester film and the glass plate (7.4.1.2), and extrude the excess material. Irradiate the test specimen in the split ring through the polyester film, in accordance with the manufacturer's instructions. Remove the test specimen from the split ring.

Prepare three specimens, and store them in water at (37 ± 1) °C for 24 h. Carry out the hardness test on the upper and lower surfaces of the specimens three times in accordance with ISO 6507-1.

7.4.4 Expression of results

Express the hardness of each surface as the mean of the three values obtained for it.

All three specimens shall meet the requirement of 5.3. Otherwise the polymer-based crown and bridge material does not comply with the requirement of 5.3.

7.5 Surface finish

Polish a test specimen prepared in accordance with the manufacturer's instructions. If no specific procedure is given by the manufacturer, polish for not longer than 1 min with an 18- to 36-ply muslin wheel at a circumferential speed of (650 ± 350) m/min and with precipitated calcium carbonate. Keep at least 10 mm between the outer diameter of the wheel and the stitching or other reinforcement.

Thoroughly clean the specimen by rinsing with water, blot dry, and visually inspect the surface for compliance with the requirement of 5.4.

NOTE A wheel with a diameter of 70 mm rotating at 1 500 r/min will have a circumferential speed of 330 m/min and a 100 mm diameter wheel rotating at 3 500 r/min will have a circumferential speed of 1 100 m/min.

Dimensions in millimetres

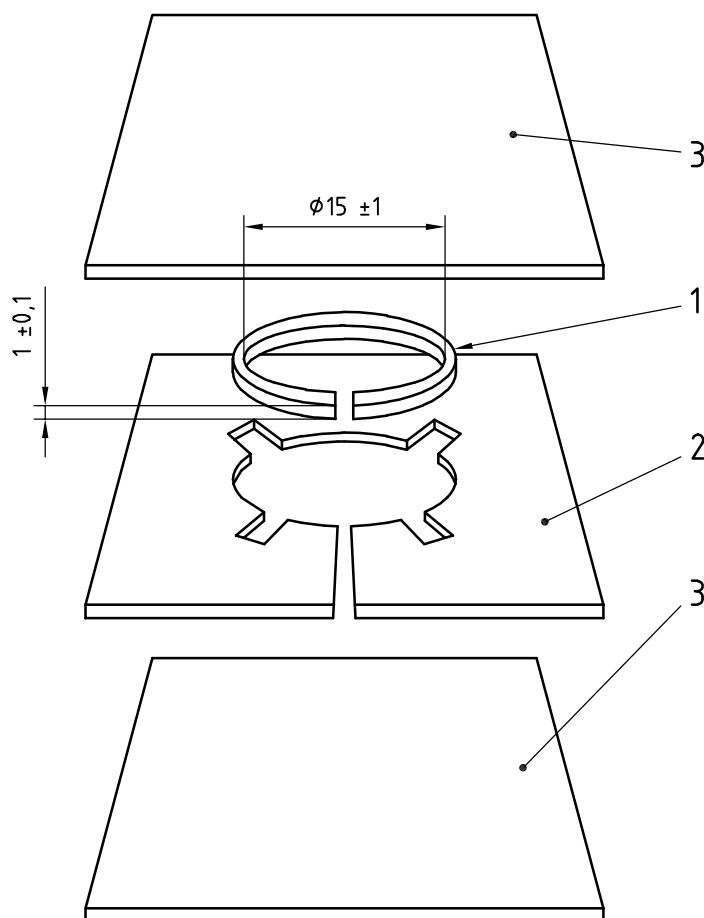
**Key**

- 1 split ring
- 2 retaining plate or former
- 3 glass or metal plates

Figure 2 — Mould for the preparation of test specimens for depth of cure, water sorption, solubility, shade consistency and colour stability

7.6 Flexural strength

7.6.1 Apparatus

7.6.1.1 Split stainless steel mould, coated with a separating medium (e.g. 3% solution of polyvinylstearyl ether wax in hexane), as shown in Figure 3, in an appropriate mounting device.

7.6.1.2 Two glass or metal plates, of approximately 30 mm × 30 mm × 2 mm.

7.6.1.3 Small screw clamp.

7.6.1.4 Polymerization apparatus, as recommended by the manufacturer.

7.6.1.5 Oven, set at (37 ± 1) °C.

7.6.1.6 Flexural strength test apparatus, appropriately calibrated, to provide a constant cross-head speed of $(1,0 \pm 0,3)$ mm/min. The apparatus consists essentially of two rods (2 mm in diameter), mounted parallel with 20 mm between centers, and a third rod (2 mm in diameter) centered between, and parallel to, the other two, so that the three rods in combination can be used to give a three-point loading to the specimen.

Other instruments with a constant loading rate of (50 ± 16) N/min may also be used.

7.6.1.7 Micrometer, with an accuracy of 0,01 mm.

7.6.2 Materials

7.6.2.1 White filter paper, as in 7.4.2.1.

7.6.2.2 Polyester film, as in 7.4.2.2.

7.6.2.3 Abrasive paper, between P220 and P320 according to ISO 6344-1.

7.6.2.4 Water, conforming to ISO 3696, Grade 2.

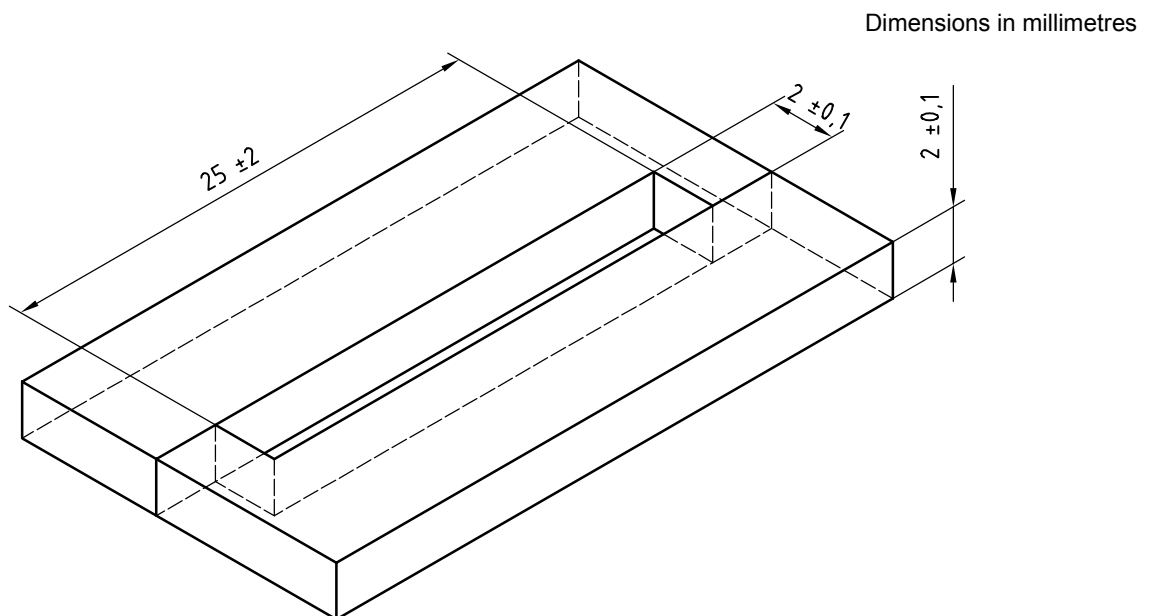

Figure 3 — Split mould for test specimens for the flexural test, made of stainless steel

7.6.3 Preparation of test specimens

7.6.3.1 Type 1 and Type 2, Class 1 polymer-based crown and bridge materials

Cover one of the metal or glass plates (7.6.1.2) with the polyester film (7.6.2.2), and position the mould (7.6.1.1) upon it. Prepare the polymer-based crown and bridge material in accordance with the manufacturer's instructions and immediately place it in the mould to a slight excess. Place a second piece of polyester film onto the polymer-based crown and bridge material in the mould and cover this with the second metal or glass plate. Apply pressure to displace excess material by means of the clamp (7.6.1.3).

Polymerize the polymer-based crown and bridge material in accordance with the manufacturer's instructions (7.6.1.4). 15 min after polymerization, remove the specimen and carefully remove any flash by gently abrading with abrasive paper (7.6.2.3), avoiding touching any other surface. Store the specimen in water (7.6.2.4) at (37 ± 1) °C (7.6.1.5) until the start of testing (7.6.4).

Prepare five specimens.

7.6.3.2 Type 2, Class 2 and Type 3 polymer-based crown and bridge materials

Use glass plates for the bottom and top plates. Cover one of the glass plates (7.6.1.2) with the white filter paper (for Type 2, Class 2 polymer-based crown and bridge material) (7.6.2.1) followed by the polyester film (7.6.2.2), and position the mould (7.6.1.1) upon it. Prepare the polymer-based crown and bridge material in accordance with the manufacturer's instructions and fill the mould with the polymer-based crown and bridge material, as described in 7.6.3.1. Place a second piece of polyester film onto the polymer-based crown and bridge material in the mould and cover this with the second glass plate. Apply pressure to displace excess material by means of the clamp (7.6.1.3).

Polymerize the polymer-based crown and bridge material in accordance with the manufacturer's instructions (7.6.1.4). Irradiate the specimen through the top glass plate, remove both glass plates and the white filter paper. Irradiate the specimen from the other side. 15 min after polymerization, remove the specimen and carefully remove any flash by gently abrading with abrasive paper (7.6.2.3), avoiding touching any other surface. Store the specimen in water (7.6.2.4) at $(37 \pm 1) ^\circ\text{C}$ (7.6.1.5) until the start of testing (7.6.4).

Prepare five specimens.

7.6.4 Procedure

At 24 h after the start of the preparation of the test specimens, measure the breadth and the height of the test specimens to an accuracy of 0,01 mm. Apply the load (7.6.1.6) at a cross-head speed of $(1 \pm 0,3)$ mm/min or at a loading rate of (50 ± 16) N/min until the specimen fractures. For Type 2, Class 2 and Type 3 materials, the load shall be applied on the first irradiated surface.

7.6.5 Expression of results**7.6.5.1 Calculation**

Calculate the flexural strength, σ_B , in megapascals, from the equation:

$$\sigma_B = \frac{3Fl}{2bh^2} \quad (1)$$

where

F is the maximum applied load, in newtons;

l is the distance, in millimetres, between the supports, i.e. 20 mm;

b is the width of the test specimen, in millimetres;

h is the height of the test specimen, in millimetres.

7.6.5.2 Treatment of results

If at least four of the results are ≥ 50 MPa, the polymer-based crown and bridge material complies with the requirement of 5.5.

If less than three of the results are ≥ 50 MPa, the polymer-based crown and bridge material does not comply with the requirement of 5.5.

If three of the results are ≥ 50 MPa, repeat the whole test. Only if all results are ≥ 50 MPa on the second occasion does the polymer-based crown and bridge material comply with the requirement of 5.5.

This treatment is summarized in Table 3.

Table 3 — Treatment of results (7.6.5.2, 7.7.5.2, 7.8.5.2)

Number of complying specimens	Compliance with requirement
First test	
4 to 5	Yes
3	Repeat test
0 to 2	No
Second test (repetition)	
5	Yes
0 to 4	No

7.7 Bond strength

7.7.1 Apparatus

7.7.1.1 Mould, of stainless steel with a slightly conical bore having a larger diameter of $(5 \pm 0,1)$ mm at one end and a smaller diameter of $(4,9 \pm 0,1)$ mm at the other end, and $(2,5 \pm 0,05)$ mm high, with sharp edges.

The mould may be coated with a separating medium, e.g. a 3 % solution of polyvinylstearyl ether wax in hexane.

7.7.1.2 Five metal plates, made by conventional dental laboratory techniques, of an alloy suitable for crown and bridge constructions.

The plates shall have the dimensions of (20 ± 1) mm \times (10 ± 1) mm \times $(2 \pm 0,5)$ mm.

The test surface shall be plane and the finish as recommended by the manufacturer. If no specific brand is recommended by the manufacturer, then the alloy or metal used shall conform with the alloys or product groups specified in ISO 1562 or ISO 8891.

7.7.1.3 Polymerization apparatus, as recommended by the manufacturer, as in 7.6.1.4.

7.7.1.4 Apparatus for thermocycling, which automatically exposes the specimen to 5 000 cycles of 30 s to 35 s in water at (5 ± 1) °C and 30 s to 35 s in water at (55 ± 1) °C.

7.7.1.5 Apparatus for testing shear bond strength (e.g. as shown in Figure 4) that allows the application of the force at a distance of $(0,5 \pm 0,02)$ mm from the surface of the metal plate (7.7.1.2).

7.7.1.6 Universal testing machine with a constant cross-head speed of $(1 \pm 0,3)$ mm/min and a system to record the force with an accuracy of ± 2 % as in 7.6.1.6.

Other instruments with a constant loading rate of (50 ± 16) N/min may also be used.

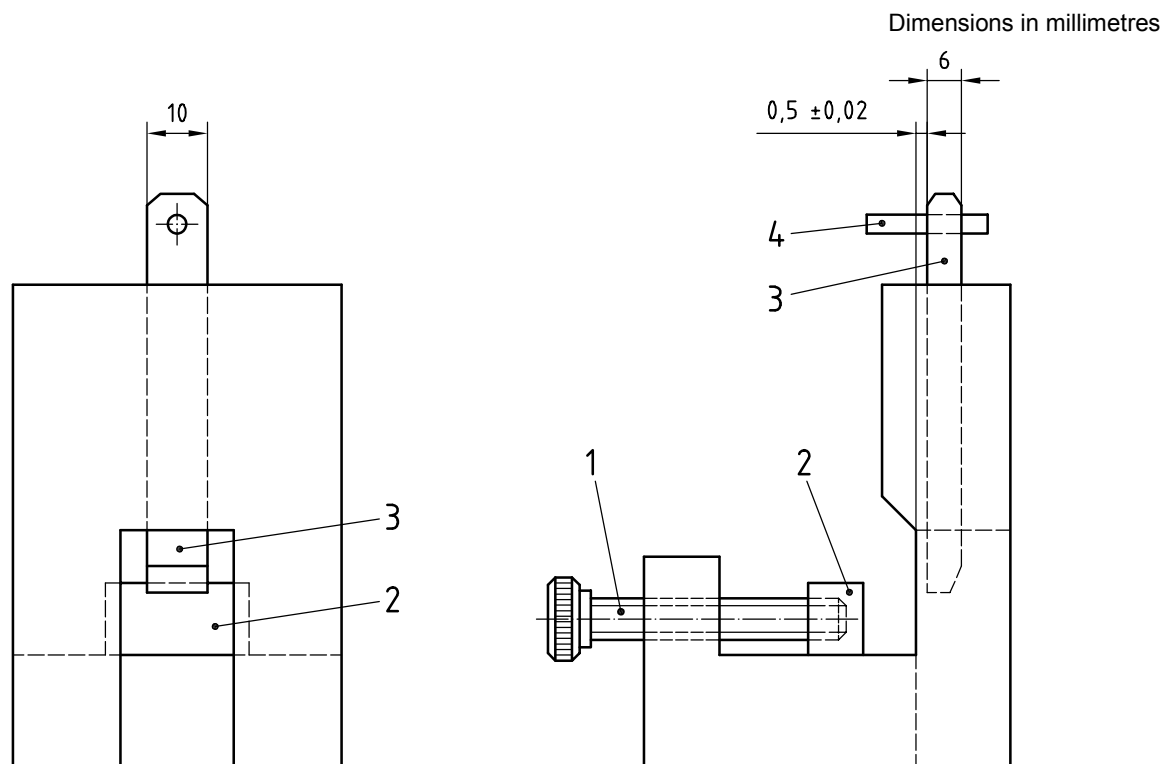

Key

- 1 fixation screw
- 2 fixation plate
- 3 plunger
- 4 stop pin

Figure 4 — Apparatus for testing shear bond strength

7.7.2 Materials

7.7.2.1 Polyester film, as in 7.4.2.2.

7.7.3 Preparation of test specimens

Treat the metal plates (7.7.1.2) as recommended by the manufacturer of the bonding system. Apply and cure the opaque resin to the bonding area as recommended by the manufacturer of the polymer-based crown and bridge material (7.7.1.3). Put the mould (7.7.1.1) onto the opaque layer with the wider opening against the opaque layer. Press the polymer-based crown and bridge material into the mould and cover it with a polyester film (7.7.2.1). Cure the polymer-based crown and bridge material according to the manufacturer's instructions (7.7.1.3 and 9.1).

Prepare five specimens.

It is recommended that the mould (7.7.1.1) be fixed on the metal plate with the help of a clamp, so that it cannot move when the polymer-based crown and bridge material is pressed into the mould.

7.7.4 Procedure

After curing the polymer-based crown and bridge material, carefully remove the mould and store the specimens dry at $(23 \pm 2) ^\circ\text{C}$ for (24 ± 2) h. Expose the specimens to 5 000 thermal cycles of 30 s to 35 s in water at $(5 \pm 1) ^\circ\text{C}$ and 30 s to 35 s in water at $(55 \pm 1) ^\circ\text{C}$ (7.7.1.4).

Remove the specimen from the water (7.7.1.4) and measure two diameters of the bonded polymer-based crown and bridge material at right angles to each other. Calculate the adhesive surface area, A , using the mean diameter.

Adjust the specimen without drying in the apparatus (Figure 4) for shear testing (7.7.1.5). Take care that the metal plate contacts the baseplate of the apparatus. Put the apparatus in the universal testing machine (7.7.1.6) and load the specimen with a constant cross head speed of $(1 \pm 0,3)$ mm/min or at a loading rate of (50 ± 16) N/min and record the load, F , at break.

7.7.5 Expression of results

7.7.5.1 Calculation

Calculate the bond strength, B , in megapascals, from the equation:

$$B = \frac{F}{A} \quad (2)$$

where

F is the load, in newtons, at break;

A is the bonded surface area, in square millimetres.

7.7.5.2 Treatment of results

Report all values of the bond strength, in megapascals, together with the type and trade name of the alloy used for the test.

If at least four of the results are ≥ 5 MPa, the polymer-based crown and bridge material complies with the requirement of 5.6.1.

If less than three of the results are ≥ 5 MPa, the polymer-based crown and bridge material does not comply with the requirement of 5.6.1.

If three of the results are ≥ 5 MPa, repeat the whole test. Only if all results are ≥ 5 MPa on the second occasion does the polymer-based crown and bridge material comply with the requirement of 5.6.1.

This treatment is summarized in Table 3.

If the manufacturer claims a value higher than 5 MPa for the bond strength, then at least four out of five, or eight out of ten if a second series is necessary as explained above, of the results shall be not less than 80 % of the claimed value, in order to comply with the requirement of 5.6.2.

7.8 Water sorption and solubility

7.8.1 Apparatus

7.8.1.1 **Split rings**, such as shown in Figure 2, as in 7.4.1.1.

7.8.1.2 **Glass plates**, as in 7.4.1.2.

7.8.1.3 **Small screw clamp**, as in 7.6.1.3.

7.8.1.4 **Polymerization apparatus**, as recommended by the manufacturer, as in 7.6.1.4.

7.8.1.5 **Plastics tweezers**.

- 7.8.1.6 **Oven**, at (37 ± 1) °C, as in 7.6.1.5.
- 7.8.1.7 **Two desiccators**, containing silica gel (7.8.2.3).
- 7.8.1.8 **Analytical balance**, with an accuracy of 0,05 mg.

7.8.2 Materials

- 7.8.2.1 **White filter paper**, as in 7.4.2.1.
- 7.8.2.2 **Polyester film**, as in 7.4.2.2.
- 7.8.2.3 **Silica gel**, freshly dried for 5 h at 130 °C.
- 7.8.2.4 **Aluminium oxide grinding powder**, with particle size approximately 0,3 µm.
- 7.8.2.5 **Water**, conforming to ISO 3696, Grade 2.

7.8.3 Preparation of test specimens

Cover one of the glass plates (7.8.1.2) with the white filter paper (7.8.2.1) [for Type 2, Class 2 and Type 3 (if photo-activated dual cure) polymer-based crown and bridge material] followed by the polyester film (7.8.2.2), and position the split ring (7.8.1.1) upon it. Prepare the polymer-based crown and bridge material in accordance with the manufacturer's instructions and immediately place it into the split ring to a slight excess, avoiding air inclusions. Place a second piece of polyester film (7.8.2.2) onto the polymer-based crown and bridge material in the mould and cover this with the second glass plate (7.8.1.2). Carefully extrude the excess material with the screw clamp (7.8.1.3). Remove the screw clamp and initiate polymerization of the polymer-based crown and bridge material in accordance with the manufacturer's instructions (7.8.1.4). For Type 2, Class 2 and Type 3 polymer-based crown and bridge materials, first irradiate through the top glass plate, remove both glass plates and the white filter paper, and irradiate the specimen from the other side.

Separate the test specimen from the split ring, wet grind it on both sides and polish it on felt to gloss to a thickness of $(1,0 \pm 0,2)$ mm with aluminium oxide (7.8.2.4) suspended in water. To avoid contamination of the specimens, handle them at all times after grinding with the plastics tweezers (7.8.1.5). Make two measurements of the diameter of the specimen at right angles to each other, to an accuracy of 0,01 mm, and calculate the mean diameter. Measure the thickness at the centre and at four equally spaced points on the circumference to an accuracy of 0,01 mm. Calculate the area, in square millimetres, from the mean diameter and, using the mean thickness, calculate the volume, V , in cubic millimetres.

Prepare five test specimens.

7.8.4 Procedure

Condition the polished specimens in a desiccator (7.8.1.7) at (37 ± 1) °C (7.8.1.6). After 22 h place the test specimens in a second desiccator (7.8.1.7) for 2 h at (23 ± 2) °C. Take out one specimen at a time and weigh each to an accuracy of 0,1 mg (7.8.1.8). Continue the drying procedure until the loss of mass of each test specimen is less than 0,1 mg within each 24 h period, and record the final mass as m_1 . Store the test specimens in 20 ml water (7.8.2.5) at (37 ± 1) °C (7.8.1.6) for 7 days. Remove each test specimen separately, wash with water (7.8.2.5) and dab with blotting paper until free from visible moisture. Wave each test specimen in the air for 15 s and weigh 1 min after removal from the water (mass m_2). After weighing, recondition the test specimens in the desiccator to a constant mass until the loss of mass of each test specimen is less than 0,1 mg within each 24 h period using the cycle described above. Record the final mass as m_3 .

Replace the silica gel with freshly dried gel after each weighing sequence (7.8.2.3).

NOTE Approximately two to three weeks may be necessary to achieve constant mass.

7.8.5 Expression of results

7.8.5.1 Calculation of water sorption

For each of the five specimens, calculate the values for water sorption, ρ_{ws} , in micrograms per cubic millimetre, to the nearest 0,1 $\mu\text{g}/\text{mm}^3$ from the equation:

$$\rho_{ws} = \frac{m_2 - m_3}{V} \quad (3)$$

where

m_2 is the mass of the specimen, in micrograms, after immersion in water for 7 days (see 7.8.4);

m_3 is the mass of the reconditioned specimen, in micrograms (see 7.8.4);

V is the volume of the specimen, in cubic millimetres (see 7.8.3).

7.8.5.2 Treatment of results for water sorption

If at least four of the results are $\leq 40 \mu\text{g}/\text{mm}^3$, the polymer-based crown and bridge material complies with the requirement of 5.7.

If less than three of the results are $\leq 40 \mu\text{g}/\text{mm}^3$, the polymer-based crown and bridge material does not comply with the requirement of 5.7.

If three of the results are $\leq 40 \mu\text{g}/\text{mm}^3$, repeat the whole test. Only if all five results are $\leq 40 \mu\text{g}/\text{mm}^3$ on the second occasion, does the polymer-based crown and bridge material comply with the requirement of 5.7, otherwise it fails.

This treatment is summarized in Table 3.

7.8.5.3 Calculation of solubility

Calculate the values for solubility, ρ_{sl} , in micrograms per cubic millimetre, for each of the five specimens to the nearest 0,1 $\mu\text{g}/\text{mm}^3$ from the equation:

$$\rho_{sl} = \frac{m_1 - m_3}{V} \quad (4)$$

where

m_1 is the mass of the conditioned specimen, in micrograms (see 7.8.4);

m_3 is the mass of the reconditioned specimen, in micrograms (see 7.8.4);

V is the volume of the specimen, in cubic millimetres (see 7.8.3).

7.8.5.4 Treatment of results for solubility

If at least four of the results are $\leq 7,5 \mu\text{g}/\text{mm}^3$, the polymer-based crown and bridge material complies with the requirement of 5.8.

If less than three of the results are $\leq 7,5 \mu\text{g}/\text{mm}^3$, the polymer-based crown and bridge material does not comply with the requirement of 5.8.

If three of the results are $\leq 7,5 \mu\text{g}/\text{mm}^3$, repeat the whole test. Only if at least four of the results are $\leq 7,5 \mu\text{g}/\text{mm}^3$ on the second occasion, the polymer-based crown and bridge material complies with the requirement of 5.8, otherwise it fails.

This treatment is summarized in Table 4.

NOTE The test for solubility is technically demanding and it is for this reason that the requirement following a second series of tests is lower than for the other tests in this International Standard. The estimation of solubility is considered to be an essential characteristic for the quality of polymer-based crown and bridge materials.

Table 4 — Treatment of results for solubility (7.8.5.4)

Number of complying specimens	Compliance with requirement
First test	
4 to 5	Yes
3	Repeat test
0 to 2	No
Second test (repetition)	
4 to 5	Yes
0 to 3	No

7.9 Shade consistency and colour stability

7.9.1 General

This test is intended to demonstrate any variation in colour between batches (5.9), and the colour stability (5.10) of a single batch, of a polymer-based crown and bridge material after xenon irradiation and after water sorption by comparing an irradiated specimen and a non-irradiated, water-immersed specimen with a dry reference specimen. Carry out the test in accordance with ISO 7491.

7.9.2 Apparatus

- 7.9.2.1 **Split rings**, such as shown in Figure 2, as in 7.4.1.1.
- 7.9.2.2 **Glass plates**, as in 7.4.1.2.
- 7.9.2.3 **Small screw clamp**, as in 7.6.1.3.
- 7.9.2.4 **Polymerization apparatus**, as recommended by the manufacturer, as in 7.6.1.4.
- 7.9.2.5 **Oven**, at $(37 \pm 1) ^\circ\text{C}$, as in 7.6.1.5.
- 7.9.2.6 **Radiation apparatus**, in accordance with ISO 7491.

7.9.3 Materials

- 7.9.3.1 **White filter paper**, as in 7.4.2.1.
- 7.9.3.2 **Polyester film**, as in 7.4.2.2.
- 7.9.3.3 **Aluminium oxide grinding powder**, with particle size approximately $0,3 \mu\text{m}$, as in 7.8.2.4.

7.9.4 Preparation of test specimens

Prepare twelve test specimens, three out of each batch (6.1: one batch; 6.2: one batch; 6.3: two further batches), in accordance with the procedure in 7.8.3, and initiate polymerization of the polymer-based crown and bridge material in accordance with the manufacturer's instructions (7.9.2.4). Separate the test specimen from the split ring, wet-grind it on both sides and polish it on felt to a high gloss and a thickness of $(1,0 \pm 0,2)$ mm with aluminium oxide (7.9.3.3) suspended in water.

7.9.5 Procedure

7.9.5.1 Specimen set 1: Store one specimen from each batch in the dark, dry at room temperature of (23 ± 2) °C for 7 days. These are the reference specimens.

7.9.5.2 Specimen set 2: Store one specimen from each batch in distilled water in the dark in the oven (7.9.2.5) at (37 ± 1) °C for 7 days. These specimens will demonstrate any change in colour due to water sorption alone.

7.9.5.3 Specimen set 3: Store one specimen from each batch in the dark, dry, in the oven (7.9.2.5) at (37 ± 1) °C for (24 ± 2) h. Remove the specimens from the oven and blank off half of each with aluminium or tin foil. Place these specimens in the radiation chamber (7.9.2.6), covered by water by (10 ± 3) mm at (37 ± 5) °C, and expose them to the radiation for 24 h. Remove the metal foil, and transfer the specimens back to the oven at (37 ± 1) °C, dry in the dark for 5 days. These specimens will demonstrate any change in colour due to water sorption and xenon lamp irradiation.

7.9.6 Colour comparison

Remove the specimens from the oven and blot the wet specimens dry.

For shade consistency, use the specimens of the two batches according to 6.1 and 6.2. Compare the colour of the equally treated specimens and halves of the specimens of set 3 for any change in colour according to ISO 7491.

For colour stability, use the specimens of the four different batches according to 6.1, 6.2 and 6.3. Compare the colour of both halves of each specimen of set 3 and all three specimens from each batch for any change in colour according to ISO 7491.

7.9.7 Expression of results for shade consistency

If there is no more than a slight difference in colour between the three pairs of specimens and halves (of set 3) that are treated in the same way, the polymer-based crown and bridge material complies with the requirement of 5.9.

7.9.8 Expression of results for colour stability

If there is no more than a slight difference in colour between the both halves of specimen set 3 and between the three specimens from one batch, the polymer-based crown and bridge material complies with the requirement of 5.10.

8 Packaging and labelling

8.1.1 Packaging

The components of the polymer-based crown and bridge material shall be supplied in such containers that the contents are adequately protected and the quality of the polymer-based crown and bridge material is not adversely altered before the expiry date marked on the package and the container [see 8.2.2 g) and 8.2.3 g)]

NOTE The containers are the immediate wrapping of the polymer-based crown and bridge material. An outer pack may be used to present the containers or a set as a single unit.

8.2 Labelling

8.2.1 General

If it is not practicable for all the above information to be included on the label of the primary container, the relevant information shall be provided on the outer pack, or included in the instructions for use, with the exception of the name of the manufacturer and/or distributor, trade name, shade or shade description, expiry date.

8.2.2 Labelling of outer pack

Each outer pack shall be labelled with at least the following information:

- a) name and the address of the manufacturer and/or distributor;
- b) trade name of the polymer-based crown and bridge material;
- c) type and class of polymer-based crown and bridge material in accordance with Clause 4 and/or the description of the material in plain language;
- d) shade(s) or description which can be related to the manufacturer's shade guide or that recommended by the manufacturer;
- e) net contents of the components, expressed in grams or millilitres;
- f) recommended storage conditions;
- g) expiry date, expressed as year and month according to ISO 8601, when stored according to the recommended conditions;
- h) lot number (batch code) referring to the manufacturer's records.

8.2.3 Labelling of containers

Each container shall be labelled with at least the following information:

- a) name and the address of the manufacturer and/or distributor;
- b) trade name of the polymer-based crown and bridge material;
- c) type and class of polymer-based crown and bridge material in accordance with Clause 4 and/or the description of the material in plain language;
- d) shade or description which can be related to the manufacturer's shade guide or that recommended by the manufacturer;
- e) net contents of the components, expressed in grams or millilitres;
- f) recommended storage conditions;
- g) expiry date, expressed as year and month according to ISO 8601, when stored according to the recommended conditions;
- h) lot number (batch code) referring to the manufacturer's records.

9 Manufacturer's instructions and information for the user

9.1 Instructions for use

Instructions for use, together with the description of the product, shall be provided by the manufacturer for the user and accompany each set or package of polymer-based crown and bridge material with at least the following information:

- a) name and address of the manufacturer and/or distributor;
- b) trade name of the polymer-based crown and bridge material;
- c) polymerization procedure, e.g. pressure, heat-, self-, visible light- and/or UV radiation-curing;
- d) range of application;
- e) if compliance with this International Standard is claimed by the manufacturer, a statement that ISO 10477 does not cover the application of these polymer-based crown and bridge materials for stress-bearing areas in posterior teeth;
- f) description of the components, including the principal organic constituents and the generic type of filler (e.g. barium glass);
- g) the range of dimensions of inorganic filler particles and the percentage by volume of total inorganic filler;
- h) means of retention and/or the method of preparation of the metal surface;
- i) if the manufacturer claims adhesion between the polymer-based crown and bridge material and the metal without macromechanical retention, then the method of use and treatment of the metal shall be stated;
- j) investing procedure, if applicable;
- k) method of preparing and proportioning the components, selecting the shade with the manufacturer's shade guide or that recommended by the manufacturer and the procedure of mixing, and the temperature, humidity and ambient light conditions that are likely to affect the polymer-based crown and bridge material adversely and all precautions to be taken;
- l) any special precautions regarding the manipulation of the polymer-based crown and bridge material including, if appropriate, the maximum proportion of tinters and blenders which may be used without detriment to the physical properties;

NOTE The ambient conditions under which this should be carried out may be included.

- m) procedure for the manipulation of the polymer-based crown and bridge material;
- n) working time, if applicable;
- o) for Type 1 polymer-based crown and bridge material, the setting time;
- p) for Type 2 polymer-based crown and bridge material, the recommended external energy source or sources, polymerization time and depth of cure;
- q) for Type 3 polymer-based crown and bridge material, the setting time, the recommended external energy source or sources and polymerization time;
- r) recommended procedure for finishing and polishing, and the polishing agent to be used;
- s) information on limitations and side effects;

- t) recommended conditions for storage (e.g. refrigeration) of the components;
- u) date-identification of publication of these manufacturer's instructions.

NOTE Additional information may be included at the discretion of the manufacturer or as required by legislation.

9.2 Shade guide

The manufacturer shall provide or recommend a suitable shade guide.

Bibliography

- [1] ISO 4049, *Dentistry — Polymer-based filling, restorative and luting materials*
- [2] ISO 6874, *Dentistry — Polymer-based pit and fissure sealants*
- [3] ISO 7405, *Dentistry — Preclinical evaluation of biocompatibility of medical devices used in dentistry — Test methods for dental materials*
- [4] ISO 10993-1, *Biological evaluation of medical devices — Part 1: Evaluation and testing*

BSI — British Standards Institution

BSI is the independent national body responsible for preparing British Standards. It presents the UK view on standards in Europe and at the international level. It is incorporated by Royal Charter.

Revisions

British Standards are updated by amendment or revision. Users of British Standards should make sure that they possess the latest amendments or editions.

It is the constant aim of BSI to improve the quality of our products and services. We would be grateful if anyone finding an inaccuracy or ambiguity while using this British Standard would inform the Secretary of the technical committee responsible, the identity of which can be found on the inside front cover. Tel: +44 (0)20 8996 9000. Fax: +44 (0)20 8996 7400.

BSI offers members an individual updating service called PLUS which ensures that subscribers automatically receive the latest editions of standards.

Buying standards

Orders for all BSI, international and foreign standards publications should be addressed to Customer Services. Tel: +44 (0)20 8996 9001. Fax: +44 (0)20 8996 7001. Email: orders@bsi-global.com. Standards are also available from the BSI website at <http://www.bsi-global.com>.

In response to orders for international standards, it is BSI policy to supply the BSI implementation of those that have been published as British Standards, unless otherwise requested.

Information on standards

BSI provides a wide range of information on national, European and international standards through its Library and its Technical Help to Exporters Service. Various BSI electronic information services are also available which give details on all its products and services. Contact the Information Centre. Tel: +44 (0)20 8996 7111. Fax: +44 (0)20 8996 7048. Email: info@bsi-global.com.

Subscribing members of BSI are kept up to date with standards developments and receive substantial discounts on the purchase price of standards. For details of these and other benefits contact Membership Administration. Tel: +44 (0)20 8996 7002. Fax: +44 (0)20 8996 7001. Email: membership@bsi-global.com.

Information regarding online access to British Standards via British Standards Online can be found at <http://www.bsi-global.com/bsonline>.

Further information about BSI is available on the BSI website at <http://www.bsi-global.com>.

Copyright

Copyright subsists in all BSI publications. BSI also holds the copyright, in the UK, of the publications of the international standardization bodies. Except as permitted under the Copyright, Designs and Patents Act 1988 no extract may be reproduced, stored in a retrieval system or transmitted in any form or by any means – electronic, photocopying, recording or otherwise – without prior written permission from BSI.

This does not preclude the free use, in the course of implementing the standard, of necessary details such as symbols, and size, type or grade designations. If these details are to be used for any other purpose than implementation then the prior written permission of BSI must be obtained.

Details and advice can be obtained from the Copyright & Licensing Manager. Tel: +44 (0)20 8996 7070. Fax: +44 (0)20 8996 7553. Email: copyright@bsi-global.com.