

**Petroleum,
petrochemical
and natural gas
industries —
Lubrication,
shaft-sealing and
control-oil systems
and auxiliaries —**

**Part 4: Self-acting gas seal support
systems**

The European Standard EN ISO 10438-4:2007 has the status of a
British Standard

ICS 75.180.20

National foreword

This British Standard is the UK implementation of EN ISO 10438-4:2007. It supersedes BS EN ISO 10438-4:2003 which is withdrawn.

The UK participation in its preparation was entrusted by Technical Committee PSE/17, Materials and equipment for petroleum, petrochemical and natural gas industries, to Panel PSE/17/-/6, Processing equipment and systems for petroleum and natural gas industries.

A list of organizations represented on this committee can be obtained on request to its secretary.

This publication does not purport to include all the necessary provisions of a contract. Users are responsible for its correct application.

Compliance with a British Standard cannot confer immunity from legal obligations.

This British Standard was published under the authority of the Standards Policy and Strategy Committee on 31 January 2008

© BSI 2008

ISBN 978 0 580 54489 7

Amendments/corrigenda issued since publication

Date	Comments

English Version

**Petroleum, petrochemical and natural gas industries -
Lubrication, shaft-sealing and control-oil systems and auxiliaries
- Part 4: Self-acting gas seal support systems (ISO 10438-
4:2007)**

Industries du pétrole, de la pétrochimie et du gaz naturel -
Systèmes de lubrification, systèmes d'étanchéité, systèmes
d'huile de régulation et leurs auxiliaires - Partie 4:
Systèmes de soutien pour les étanchéités au gaz auto-
actionnées (ISO 10438-4:2007)

Erdöl-, petrochemische und Erdgasindustrie - Schmieröl-,
Sperröl- und Regelölversorgungsanlagen und Hilfsanlagen
- Teil 4: Sperrgasversorgungsanlagen (ISO 10438-4:2007)

This European Standard was approved by CEN on 14 December 2007.

CEN members are bound to comply with the CEN/CENELEC Internal Regulations which stipulate the conditions for giving this European Standard the status of a national standard without any alteration. Up-to-date lists and bibliographical references concerning such national standards may be obtained on application to the CEN Management Centre or to any CEN member.

This European Standard exists in three official versions (English, French, German). A version in any other language made by translation under the responsibility of a CEN member into its own language and notified to the CEN Management Centre has the same status as the official versions.

CEN members are the national standards bodies of Austria, Belgium, Bulgaria, Cyprus, Czech Republic, Denmark, Estonia, Finland, France, Germany, Greece, Hungary, Iceland, Ireland, Italy, Latvia, Lithuania, Luxembourg, Malta, Netherlands, Norway, Poland, Portugal, Romania, Slovakia, Slovenia, Spain, Sweden, Switzerland and United Kingdom.



EUROPEAN COMMITTEE FOR STANDARDIZATION
COMITÉ EUROPÉEN DE NORMALISATION
EUROPÄISCHES KOMITEE FÜR NORMUNG

Management Centre: rue de Stassart, 36 B-1050 Brussels

Foreword

This document (EN ISO 10438-4:2007) has been prepared by Technical Committee ISO/TC 67 "Materials, equipment and offshore structures for petroleum and natural gas industries" in collaboration with Technical Committee CEN/TC 12 "Materials, equipment and offshore structures for petroleum, petrochemical and natural gas industries", the secretariat of which is held by AFNOR.

This European Standard shall be given the status of a national standard, either by publication of an identical text or by endorsement, at the latest by June 2008, and conflicting national standards shall be withdrawn at the latest by June 2008.

Attention is drawn to the possibility that some of the elements of this document may be the subject of patent rights. CEN [and/or CENELEC] shall not be held responsible for identifying any or all such patent rights.

This document supersedes EN ISO 10438-4:2003.

According to the CEN/CENELEC Internal Regulations, the national standards organizations of the following countries are bound to implement this European Standard: Austria, Belgium, Bulgaria, Cyprus, Czech Republic, Denmark, Estonia, Finland, France, Germany, Greece, Hungary, Iceland, Ireland, Italy, Latvia, Lithuania, Luxembourg, Malta, Netherlands, Norway, Poland, Portugal, Romania, Slovakia, Slovenia, Spain, Sweden, Switzerland and the United Kingdom.

Endorsement notice

The text of ISO 10438-4:2007 has been approved by CEN as a EN ISO 10438-4:2007 without any modification.

INTERNATIONAL
STANDARD

ISO
10438-4

Second edition
2007-12-15

**Petroleum, petrochemical and natural gas
industries — Lubrication, shaft-sealing
and control-oil systems and auxiliaries —**

**Part 4:
Self-acting gas seal support systems**

*Industries du pétrole, de la pétrochimie et du gaz naturel — Systèmes
de lubrification, systèmes d'étanchéité, systèmes d'huile de régulation
et leurs auxiliaires —*

*Partie 4: Systèmes de soutien pour les étanchéités au gaz
auto-actionnées*



Reference number
ISO 10438-4:2007(E)

Contents

Page

Foreword.....	iv
Introduction	v
1 Scope	1
2 Normative references	1
3 Terms, abbreviated terms and definitions	1
4 General.....	2
4.1 System selection.....	2
4.2 Basic design.....	2
4.3 Gas filters	4
4.4 Transfer valves.....	4
4.5 Condensate traps.....	4
5 Piping and tubing.....	5
6 Instrumentation, control and electrical systems	5
6.1 General.....	5
6.2 Alarms and shutdowns	5
6.3 Instrumentation.....	6
7 Inspection, testing and preparation for shipment.....	7
7.1 General.....	7
7.2 Inspection	7
7.3 Testing	7
7.4 Preparation for shipment	8
8 Vendor's Data	8
8.1 Proposal.....	8
8.2 Spare parts	8
Annex A (informative) Datasheets	9
Annex B (informative) Piping and instrument diagrams	10
Annex C (informative) Inspector's checklist.....	25
Annex D (informative) Dry-gas-seal connection terminology and configurations	27
Bibliography	30

Foreword

ISO (the International Organization for Standardization) is a worldwide federation of national standards bodies (ISO member bodies). The work of preparing International Standards is normally carried out through ISO technical committees. Each member body interested in a subject for which a technical committee has been established has the right to be represented on that committee. International organizations, governmental and non-governmental, in liaison with ISO, also take part in the work. ISO collaborates closely with the International Electrotechnical Commission (IEC) on all matters of electrotechnical standardization.

International Standards are drafted in accordance with the rules given in the ISO/IEC Directives, Part 2.

The main task of technical committees is to prepare International Standards. Draft International Standards adopted by the technical committees are circulated to the member bodies for voting. Publication as an International Standard requires approval by at least 75 % of the member bodies casting a vote.

Attention is drawn to the possibility that some of the elements of this document may be the subject of patent rights. ISO shall not be held responsible for identifying any or all such patent rights.

ISO 10438-4 was prepared by Technical Committee ISO/TC 67, *Materials, equipment and offshore structures for petroleum, petrochemical and natural gas industries*, Subcommittee SC 6, *Processing equipment and systems*.

This second edition cancels and replaces the first edition (ISO 10438-4:2003), which has been technically revised.

ISO 10438 consists of the following parts, under the general title *Petroleum, petrochemical and natural gas industries — Lubrication, shaft-sealing and control-oil systems and auxiliaries*:

- *Part 1: General requirements*
- *Part 2: Special-purpose oil systems*
- *Part 3: General-purpose oil systems*
- *Part 4: Self-acting gas seal support systems*

Introduction

This International Standard was developed jointly with API 614, 5th edition. ISO 10438 is divided into four parts corresponding to the four chapters of API 614.

Users of this part of ISO 10438 should be aware that further or differing requirements might be needed for individual applications. This part of ISO 10438 is not intended to inhibit a vendor from offering, or the purchaser from accepting, alternative equipment or engineering solutions for the individual application. This may be particularly appropriate where there is innovative or developing technology. Where an alternative is offered, the vendor should identify any variations from this part of ISO 10438 and provide details. It is intended that this part of ISO 10438 be used in conjunction with 10438-1.

This part of ISO 10438 requires the purchaser to specify certain details and features.

A bullet (•) at the beginning of a clause or subclause indicates that either a decision is required or further information is to be provided by the purchaser. This information or decision should be indicated on the datasheet(s); otherwise it should be stated in the quotation request or in the order.

In this International Standard, US customary (USC) units are included in brackets for information.

Petroleum, petrochemical and natural gas industries — Lubrication, shaft-sealing and control-oil systems and auxiliaries —

Part 4: Self-acting gas seal support systems

1 Scope

This part of ISO 10438 in conjunction with ISO 10438-1 specifies requirements for support systems for self-acting gas seals (dry gas seals), for example as described in ISO 10439 and ISO 10440-1. These systems can serve equipment such as compressors, gears, pumps and drivers.

NOTE For the purposes of this statement of scope, API 617 is equivalent to ISO 10439 and API 619 is equivalent to ISO 10440-1.

2 Normative references

The following referenced documents are indispensable for the application of this document. For dated references, only the edition cited applies. For undated references, the latest edition of the referenced document (including any amendments) applies.

ISO 10438-1:2007, *Petroleum, petrochemical and natural gas industries — Lubrication, shaft-sealing and control-oil systems and auxiliaries — Part 1: General requirements*

ISO 15649, *Petroleum and natural gas industries — Piping*

API RP 520, *Sizing, Selection, and Installation of Pressure-Relieving Devices in Refineries — Part I: Sizing and Selection*

API RP 520, *Sizing, Selection, and Installation of Pressure-Relieving Devices in Refineries — Part II: Installation*

API 526, *Flanged Steel Pressure Relief Valves*

ANSI/ASME B31.3, *Process Piping*

3 Terms, abbreviated terms and definitions

For the purposes of this document, the terms, abbreviated terms and definitions given in ISO 10438-1 apply.

4 General

4.1 System selection

Datasheets for system specifications are provided in Annex A.

Annex B provides schemas of typical system components and diagrams of typical, complete dry gas seal support systems and modules. These schemas and diagrams illustrate the general philosophy and requirements of this part of ISO 10438 and are included to assist the purchaser in the selection of an appropriate system. The purchaser and the vendor shall mutually agree upon an acceptable system.

Annex C provides an inspector checklist of typical items reviewed by the purchaser.

4.2 Basic design

4.2.1 The equipment (including auxiliaries) covered by this part of ISO 10438 shall be designed and constructed for a minimum service life of 20 years and at least 5 years of uninterrupted operation.

NOTE It is recognized that this is a design criterion.

4.2.2 If specified, the purchaser may specify the vendor responsible for each portion of the design, scope of supply, installation and performance of the dry gas seal system. If the purchaser is not the end user, then the end user shall approve the vendors specified.

4.2.3 The purchaser shall specify the equipment's normal operating point and all other operating points. Other parameters required for the design of the seal support system, such as gas composition, maximum and minimum flare pressure, maximum and minimum sealing pressure and settle-out pressure shall also be specified.

4.2.4 Unless otherwise specified, the lube-oil console and the dry gas seal module shall be mounted on separate skids.

4.2.5 The dry gas seal system shall be designed to serve the full range of equipment operating conditions specified. These conditions may include but are not limited to the following:

- a) settle-out pressures;
- b) process relief-valve settings;
- c) shop test and field run-ins;
- d) start-up conditions;
- e) gas composition.

NOTE This requires a detailed system review with the equipment suppliers, purchaser and owner, and is normally finalized at the coordination meeting.

4.2.6 Control systems shall provide adequate gas velocity across the labyrinths at all clearances, including minimum labyrinth clearance to twice the maximum design labyrinth clearance to prevent migration of contaminants from the process gas.

NOTE In a flow-control system, velocity across the labyrinths decreases as clearances increase.

4.2.7 All gas streams (including alternate, backup, start-up sources) into the seal shall be provided at a temperature of at least 20 K (35 °R) above their dew point in order to preclude the possibility of liquid entering the dry gas seal.

NOTE 1 On some systems, the discharge temperature of the compressor gas stream might not provide this dew-point margin.

NOTE 2 In some cases, this can require heaters and/or heat tracing by the owner.

The dew-point margin shall be maintained throughout the seal and not just at the supply connections.

In some cases, alternate gases to the process gas should be considered for start-up or dew-point reasons.

- **4.2.8** If specified, additional provision for seal-gas conditioning as specified by the purchaser shall be furnished.

NOTE Gas conditioning can involve heat tracing, alternate seal-gas sources, coalescing filters, or other provisions.

4.2.9 Valved vents, drains and piping shall be furnished to permit draining, cleaning and refilling of idle components, such as filter elements, while the equipment is in operation.

4.2.10 Seal-gas module piping shall be arranged such that it can be manually drained prior to start-up to avoid the possibility of condensed liquids entering the seals.

This is also a requirement for interconnecting piping that shall be followed by the packager or installation contractor.

- **4.2.11** The purchaser shall specify when and where double block and bleed valves are required for isolating a component and how they are arranged.

NOTE Double block valves are normally provided where there are safety or environmental issues associated with the reliability of a single block valve.

- **4.2.12** Filters, drain traps and other pressure vessels shall be in accordance with the specified pressure design code. The purchaser shall specify if it is necessary that the vessels be code stamped.

NOTE 1 Most vessels for the gas seal module are smaller than the size required for the ASME code stamp.

NOTE 2 Code stamping might not be applicable for pressure design codes other than ASME.

NOTE 3 Reference can be made to ISO 10438-1:2007, 4.5.7. Local jurisdictions can require a code stamp.

4.2.13 The module and components shall perform on test and on its permanent foundation within the specified acceptance criteria. After installation, the performance of the module shall be the joint responsibility of the purchaser and the vendor who has unit responsibility.

- **4.2.14** The vendor shall advise the purchaser of, and both parties shall mutually agree upon, any special provisions that are necessary to ensure that an adequate backup supply of seal gas and seal buffer gas or seal separation gas is maintained in the event of complete loss of the main seal-gas supply source. These provisions may include alternate seal-gas supply sources, backup gas bottles and special arrangements for start-up, purge gas and settle-out conditions. Provisions shall be adequate for block-in vent or purge situations as applicable. The purchaser shall specify the required block-in time. The purchaser and the vendor shall mutually agree upon the backup system and its component requirements.

4.2.15 Block valves that interrupt the gas flow to the equipment shall not be installed in gas supply lines downstream of the filters unless the block valves are part of a component block and bypass arrangement.

4.2.16 The support structure shall be stainless steel or carbon steel and painted.

4.2.17 Dry-gas-seal system piping size and vents shall be sized to prevent over-pressurization of the bearing housings in the event of a failure of the seal.

This is a system requirement, which should be coordinated between the equipment supplier (seal housing connection sizes), dry-gas-seal system module designer (vent-piping sizes) and the installation designer (vent sizes and piping lengths).

4.3 Gas filters

4.3.1 General

4.3.1.1 The filters shall have a minimum efficiency of 98,8 % on particles less than or equal to 4 μm (beta ratio, $\beta_4 \geq 85$) and shall be in accordance with the dry gas seal manufacturer's requirements.

4.3.1.2 Gas filters shall be sized for a collapse differential pressure of at least 500 KPa (5 bar; 70 psi).

4.3.1.3 The filter element material shall be designed for the maximum gas temperature and shall be compatible with the gas filtered.

4.3.1.4 Unless otherwise specified, filters in flammable or toxic services shall have bolted covers.

4.3.1.5 Unless otherwise specified, the filter housings shall be stainless steel.

4.3.2 Particulate filter sizing

4.3.2.1 For differential-pressure control systems, filters shall be sized for a clean pressure drop of 21 kPa (0,21 bar; 3 psid) at twice the gas flow calculated at maximum labyrinth design clearance and at the design differential pressure.

4.3.2.2 For flow-control systems, filters shall be sized for a clean pressure drop of 10 kPa (0,10 bar; 40 in of water) at three times normal flow.

4.3.3 Coalescing filter sizing

When the gas contains liquids or moisture, coalescing filters shall be provided. If the knockout rates exceed 50 % of the coalescing capacity of the element, a mechanical separator shall be installed ahead of the filter assembly.

4.4 Transfer valves

4.4.1 For flammable or toxic service, there shall be no leakage into the isolated system (such as the standby filter). When an isolation system is designed such that total shutoff of flow adversely affects the seal, the vendor shall provide cautionary warning signs to that effect on the dry-gas-seal system module.

NOTE Four individual block valves or a combination of block valves and transfer valves can be required for positive isolation to transfer filters.

4.4.2 Transfer valves shall have steel bodies. Valve stems, plugs or balls shall be made of stainless steel.

4.5 Condensate traps

4.5.1 One condensate drain trap per coalescing filter shall be provided if condensate can be present at the coldest operating temperature in the seal gas and or the seal buffer gas. Gas downstream of the filter and trap shall be kept liquid-free.

NOTE For some services, heat tracing and/or drain traps at supply piping low points downstream of the control valve can be required.

4.5.2 Non-repairable float traps are acceptable for services below 3,1 MPa (31 bar; 450 psig) if approved by the purchaser.

4.5.3 A mechanical, float-type trap is permitted for gas pressures less than or equal to 6,8 MPa (68 bar; 1 000 psig).

Level-transmitter, control-type traps shall be used when gas fouling can interfere with the operation of mechanical, float-type traps.

4.5.4 For pressures greater than 6,8 MPa (68 bar; 1 000 psig), snap-acting level transmitter/controllers and separate control valves shall be used.

4.5.5 All low points upstream of filters shall have drain valves.

4.5.6 Traps configured as specified in 4.5.2 and 4.5.3 shall be furnished with reflex-type gauge glasses, magnetic level indicators or other types of level indication as specified. The inlet piping shall enter the seal traps above the condensate level of the traps.

4.5.7 Unless otherwise specified, drain lines for traps on the system module shall be manifolded and a flange connection supplied at the edge of the module.

5 Piping and tubing

5.1 The vendor shall furnish the dry-gas-seal module, including mounted appurtenances, located within the confines of the base area. All connections on the module for interconnecting piping to the equipment shall be flanged. Module interface flanges connected to tubing shall be supported from the module structure.

NOTE All mounted appurtenances are kept within the confines of the base area to keep work areas and walkways as free as possible from obstructions and to protect tubing from damage. Externally supported, flanged exit connections on tubing are used to protect the tubing from external loads.

The interconnecting system between the module and equipment should be rigid pipe. The interconnecting system is provided by the vendor as defined in the datasheets. Piping and tubing shall be austenitic stainless steel and shall be in accordance with ISO 10438-1:2007, Tables 1, 5 and 6 unless otherwise specified.

5.2 Unless otherwise specified, dry-gas-seal modules designed for working pressures (gauge) below 6 200 KPa (62 bar; 900 psi) shall have the gas flow lines manufactured from stainless steel tubing or stainless steel piping.

5.3 Unless otherwise specified, dry-gas-seal modules with working pressures (gauge) greater than 6 200 KPa (62 bar; 900 psi) shall have gas flow lines manufactured from stainless steel piping.

5.4 Instrument valves within the dry-gas-seal module on tubing lines shall be tubing valves.

5.5 Control valves shall have steel bodies and stainless steel trim. Where practical, valves shall be removable without removing piping or tubing.

NOTE Smaller valves can have threaded connections that require fittings to be disconnected.

5.6 Threaded connections in toxic and flammable service shall be used only as approved by the purchaser.

NOTE Small component size can dictate the use of threaded components. Seal welding is an acceptable alternative but results in maintenance implications.

6 Instrumentation, control and electrical systems

6.1 General

Instrumentation shall be in accordance with ISO 10438-1:2007, Clause 6, except as modified in 6.2 to 6.3.

6.2 Alarms and shutdowns

6.2.1 Unless otherwise specified, the vendor shall furnish and mount, as a minimum, the primary alarm and shutdown contacts specified in Table 1.

Table 1 — Conditions requiring alarms and shutdowns

Condition	Alarm	Shutdown
Seal-gas supply for all seal types ^a except double	x	—
Seal-gas supply for double seal	x	x
Seal-gas supply, high flow, for double seal	x	—
High vent-gas pressure or flow ^b	x	x ^f
High primary vent-gas pressure or flow on tandem seal or tandem seal with intermediate labyrinth ^c	x	—
High secondary vent-gas pressure or flow on tandem seal or tandem seal with intermediate labyrinth ^c	x	—
Secondary seal-gas pressure or flow ^d	x	—
Separation-gas pressure or flow ^e	x	—
Low seal-gas, buffer-gas or separation-gas differential pressure or flow	x	—
High differential pressure for each filter set	x	—
<p>^a See Annex D for seal configurations.</p> <p>^b As an alternative, the pressure differential, Δp, across the inboard seal faces of a double seal can be alarmed.</p> <p>^c If secondary vent gas is not monitored, then high primary vent gas shall be a shutdown. If both primary and secondary flows are high, the unit should shutdown. If primary vent gas is at a sustained high level, the unit should undergo a controlled shutdown.</p> <p>^d Alarm on flow if pressure-controlled, and on pressure if flow-controlled.</p> <p>^e Use as a permissive to start lube-oil system.</p> <p>^f Shutdown for single seal only.</p>		

● **6.2.2** Pressure or flow control and sensing shall be as specified or as mutually agreed.

● **6.2.3** The purchaser shall specify shutdown and alarms in accordance with one of the three arrangements detailed in ISO 10438-1:2007, 6.2.3.

6.3 Instrumentation

6.3.1 Flow indicators

6.3.1.1 Unless otherwise specified, the flow indicators shall be of the armoured type and have an internal magnetic float or rotameter design or an integral orifice and differential-pressure (DP) cell.

● **6.3.1.2** If specified, turbine flow transmitters shall be supplied.

6.3.1.3 Unless otherwise specified, flow meters in inert separation-gas services may be of the plastic rotameter design.

● **6.3.1.4** If specified, seal-gas flow measurement shall be by an electronic device such as a linear mass flow meter, venturi or turbine type. The purchaser shall specify whether the readout device is supplied by the module manufacturer or by the purchaser.

6.3.2 Relief valves

6.3.2.1 The vendor shall furnish the relief valves that are installed on equipment or piping that the vendor is supplying. Other relief valves related to equipment or piping outside the system that the vendor is supplying shall be furnished by the purchaser. The vendor's quotation shall list all relief valves and shall clearly state that these valves shall be furnished by the vendor. Only relief valves for gas service are required to meet the limiting relief-valve requirements specified in 6.3.2.2.

6.3.2.2 The sizing, selection and installation of gas relief valves shall meet the requirements of API 520, Parts I and II. Relief valves shall be in accordance with API 526. The vendor shall determine the size and set pressure of all relief valves within his scope of supply and recommend the size and setting of relief valves supplied by others required to protect the equipment he supplies. Relief-valve sizes and settings shall take into account all possible modes of equipment failure.

6.3.2.3 Unless otherwise specified, relief valves shall have steel bodies.

6.3.2.4 Unless otherwise specified, relief valves shall be arranged such that they can be removed for testing without shutting down the equipment.

6.3.3 Rupture disks

6.3.3.1 Where rupture disks are used, a positive indication shall be provided to indicate rupture disk status.

6.3.3.2 Where rupture disks are used, they shall be set sufficiently high to avoid spurious ruptures and shall be designed to avoid failures from causes other than over-pressurization.

6.3.3.3 Rupture disks shall be arranged such that they can be replaced without shutting down the equipment.

7 Inspection, testing and preparation for shipment

7.1 General

7.1.1 Inspection, testing and preparation for shipment shall be carried out in accordance with ISO 10438-1:2007, Clause 7, unless otherwise specified in 7.2 to 7.4 of this part of ISO 10438.

- **7.1.2** If specified, the purchaser's or the vendor's representative or both shall indicate compliance in accordance with the inspector's checklist (Annex C) by initialling, dating and submitting the completed checklist to the purchaser prior to shipment.

7.2 Inspection

Inspections shall occur in accordance with ISO 10438-1:2007, 7.2.

7.3 Testing

7.3.1 General

7.3.1.1 Equipment shall be tested in accordance with the requirements of 7.3.3 and ISO 10438-1:2007, 7.3. The purchaser and the vendor shall mutually agree if a pneumatic test in accordance with ISO 15649 or ANSI/ASME B31.3 at 110 % of design pressure may be substituted. Other tests may be specified and shall be jointly developed by the purchaser and the vendors.

- **7.3.1.2** If specified, the dry-gas-seal module shall be used during the main equipment's mechanical run test.

Gas conditions during the mechanical run or factory performance run should be considered in the dry gas seal module design.

7.3.2 Piping spools

Piping spools may be hydrotested individually in accordance with ISO 10438-1:2007, 7.3.2.

It is not recommended to hydrotest the system due to concerns with water being left in the system.

NOTE 1 Reference can be made to 7.3.3.1 for gas leak test requirements.

NOTE 2 ISO 15649 does not require hydrotesting when a pneumatic test is performed.

7.3.3 Operational tests

7.3.3.1 A gas leak test at 110 % of maximum allowable working pressure shall be performed on the system.

7.3.3.2 Unless otherwise specified, test gas shall be helium for seal gas of relative molecular mass 12 or less and air or nitrogen for seal gas of relative molecular mass greater than 12. Test gas shall be clean and dry.

7.3.3.3 A cleanliness test of the dry-gas-seal module shall be conducted at the vendor's shop with the job filter or new test filter (of equal filtration capability) elements installed. A 100 mesh screen shall be fastened to the outlet of the module flange for each gas line from the module. The module shall be blown for a 5 min period with a nominal 700 kPa (7 bar; 100 psig), dry-filtered [dew point not greater than $-7\text{ }^{\circ}\text{C}$ ($20\text{ }^{\circ}\text{F}$) and filtered to $\beta_2 \geq 10$] gas. The screen shall be inspected for discoloration and cleanliness. Any hard particles or discoloration shall be cause for rejection.

7.3.3.4 If specified, a functional test proposed by the vendor and agreed to by the purchaser of the dry-seal-gas module shall be performed at the vendor's shop.

7.4 Preparation for shipment

The dry-seal-gas module shall be prepared for shipment in accordance with ISO 10438-1:2007, 7.4.

8 Vendor's Data

8.1 Proposal

The seal vendor's proposals shall incorporate requirements for the dry-seal-gas module to allow successful uninterrupted operation of the seal system for a minimum of 5 years.

8.2 Spare parts

The vendor shall ship the unit with clean filter elements installed.

Annex A (informative)

Datasheets

This annex contains a link to datasheets in both SI and USC units, together with an explanatory note. To access the appropriate datasheets, click on "[Datasheet](#)", then on the page tab for the corresponding figure (Figure A.1 — Dry-gas-seal module; Figure A.2 — Application data for a dry-gas-seal module). Select the appropriate set of units from the menu available on the first page.

The options for units are as follows:

- USC units;
- SI units (MPa);
- SI units (kPa);
- metric (kg/cm²);
- hybrid.

Annex B
(informative)

Piping and instrument diagrams

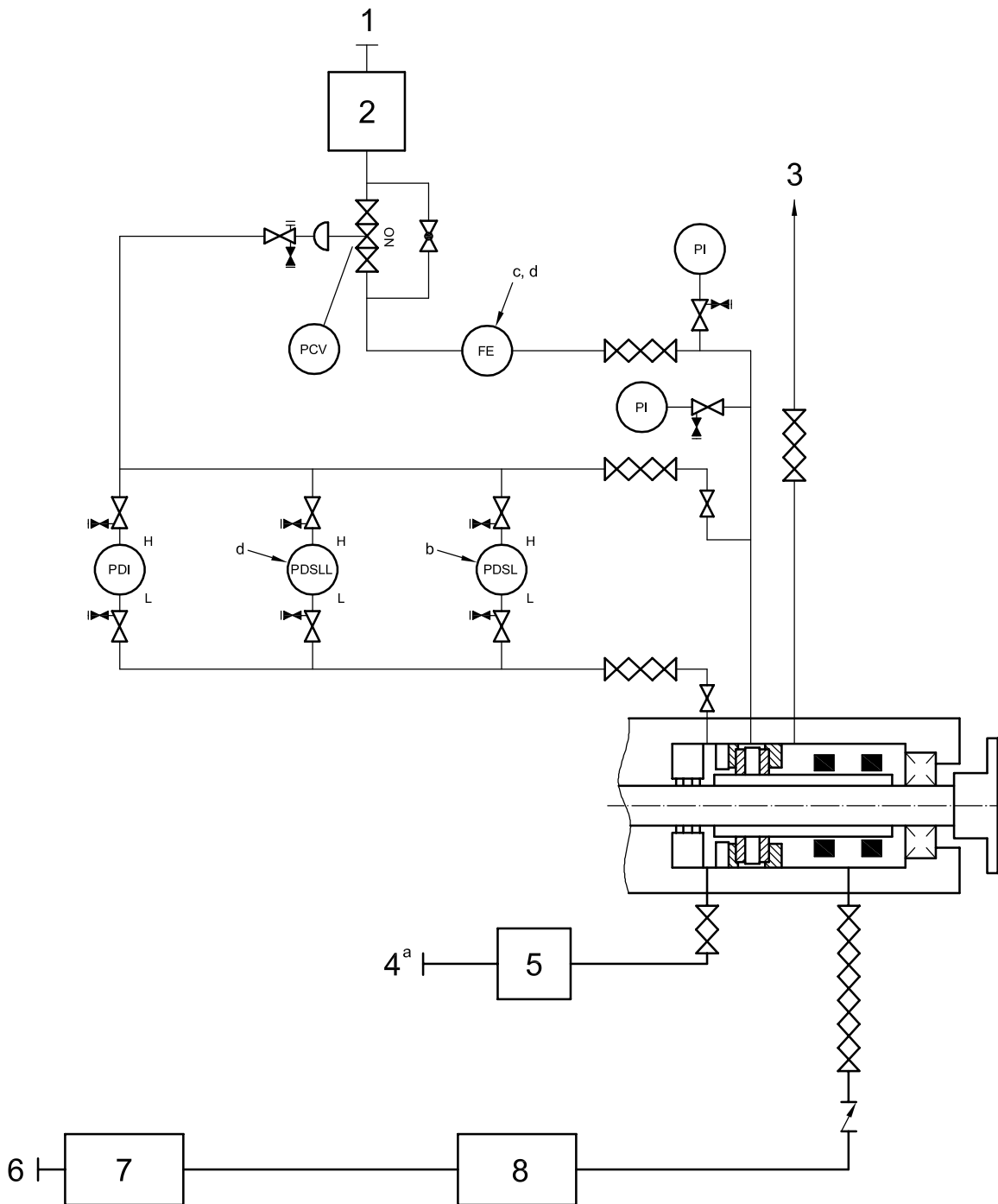

Key

- | | |
|--|---|
| 1 seal-gas supply | 5 seal buffer gas, inlet filter module (Figure B.5) |
| 2 gas seal filter module (Figure B.5) | 6 separation gas |
| 3 vent gas (composed of seal and separation gas) to flare or safe area | 7 separation-gas filter module (Figure B.5) |
| 4 seal buffer gas supply | 8 separation-gas inlet module |

^a Required if process gas is saturated or contains fines; recommended in any event.

^b Required to ensure seal-gas flow across gas seal surfaces.

^c Figure B.1, option A: Flow element to monitor condition of seal.

^d Refer to Table 1. Loss of seal gas to a double seal can cause immediate seal damage.

NOTE Reference can be made to Annex D for terminology, to ISO 10438-1:2007, Clause 3, for definitions and to ISO 10438-1:2007, Annex B for symbols.

Figure B.1 — Double dry gas seal system

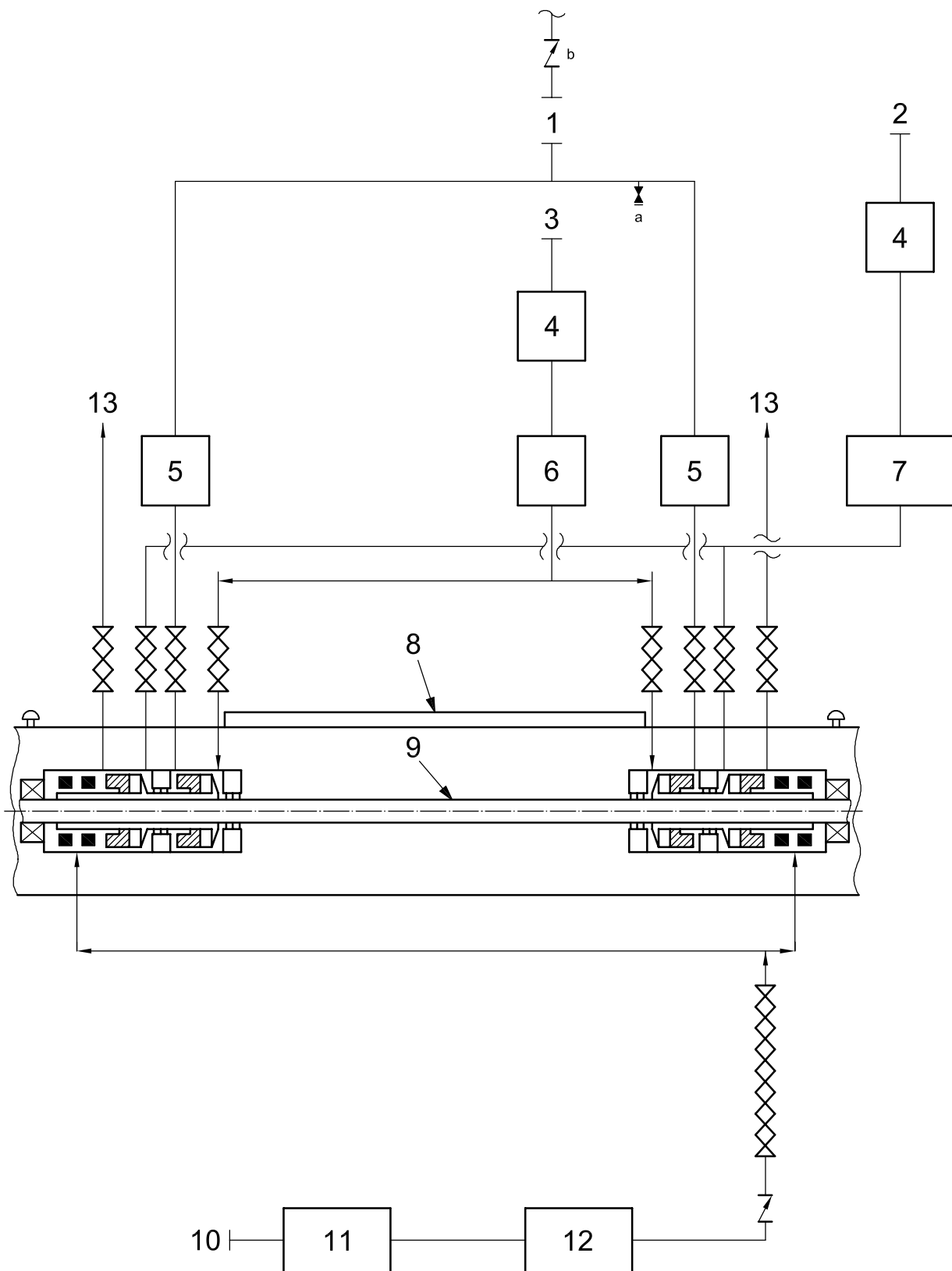

Key

- | | | | |
|---|--|----|--|
| 1 | primary vent to safe area or flare | 8 | balance line (multi-stage beam-type compressor with equalized seals) |
| 2 | secondary seal-gas supply | 9 | compressor |
| 3 | primary seal-gas supply (normally filtered process gas from discharge or secondary supply) | 10 | separation gas |
| 4 | filter module (Figure B.5) | 11 | separation-gas filter module |
| 5 | primary vent-outlet module | 12 | separation-gas inlet module |
| 6 | primary seal-gas-inlet module | 13 | secondary vent |
| 7 | secondary seal-gas-inlet module | | |

^a Test valve.

^b Check valve normally supplied by purchaser.

NOTE This seal type only leaks secondary seal gas to atmosphere. The gas for the secondary seal is, therefore, normally chosen to be an inert gas such as nitrogen.

Figure B.2 — Tandem dry gas seal with intermediate labyrinth system

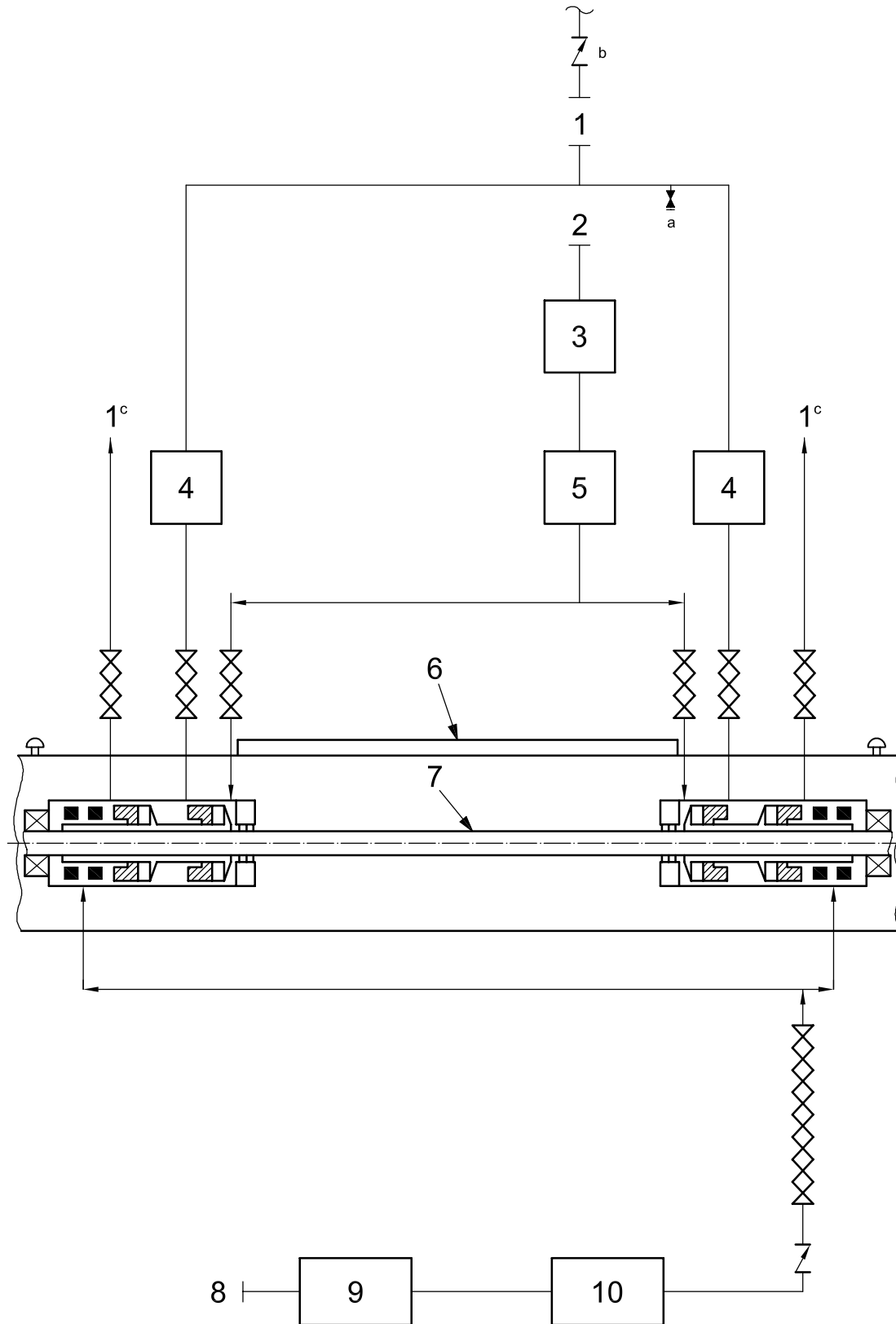

Key

- | | | | |
|---|--|----|--|
| 1 | secondary vent to flare or safe area | 7 | compressor |
| 2 | seal-gas supply | 8 | separation gas |
| 3 | seal-gas filter module (Figure B.5) | 9 | separation-gas filter module |
| 4 | primary vent-gas outlet module (Figures B.15 or B.16) | 10 | separation-gas inlet module (Figures B.18, B.19 or B.20) |
| 5 | seal-gas inlet module (Figures B.8, B.9, B.10 or B.11) | | |
| 6 | balance line (multi-stage beam-type compressor with equalized seals) | | |
- a Test valve.
- b Check valve normally supplied by purchaser.
- c If secondary vent is sent to flare, there is a potential to flow flare gas into the bearing housings. A customer-supplied check valve or other safeguards can be required.

Figure B.3 — Tandem dry gas seal system

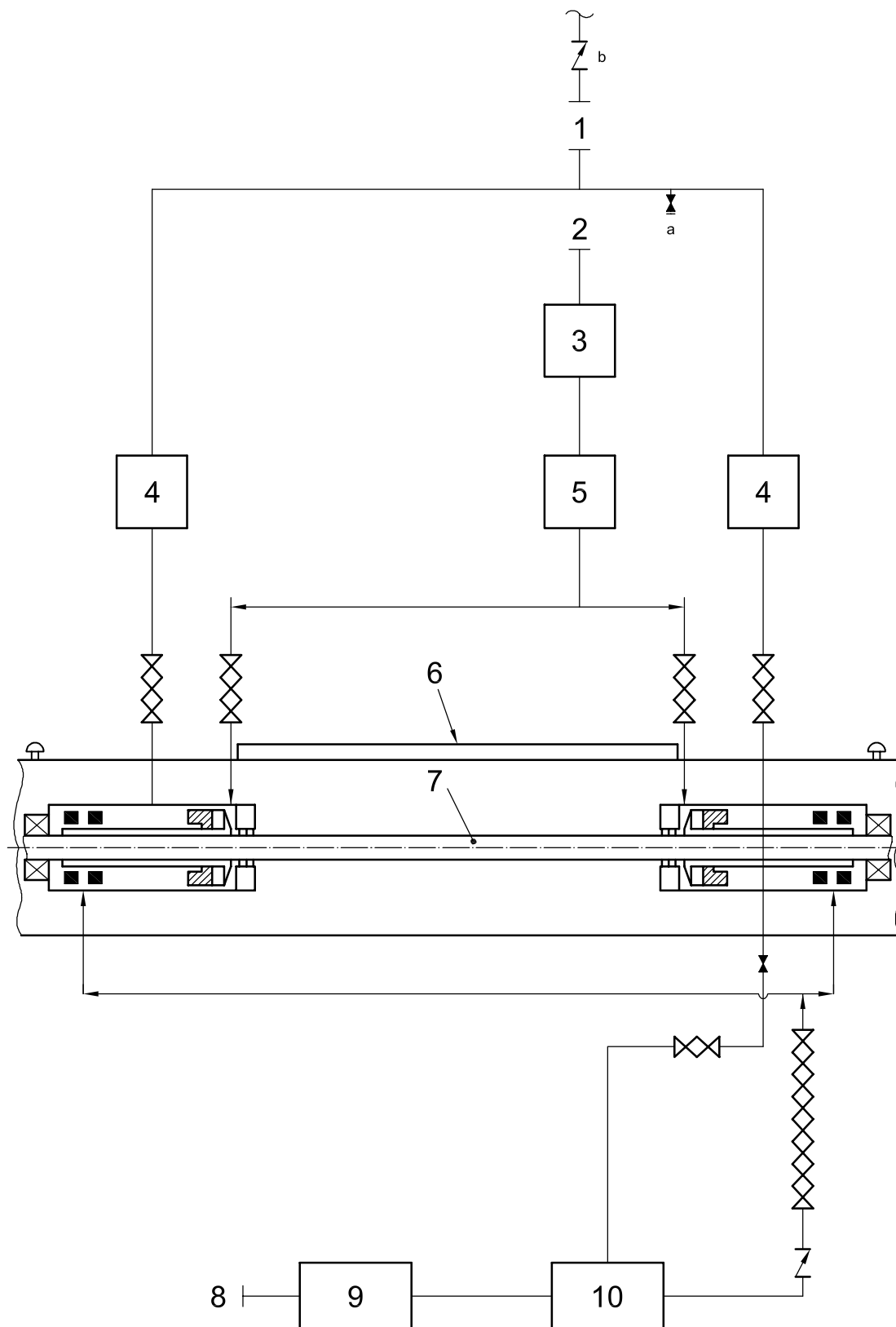

Key

- | | |
|--|---|
| 1 to flare or safe area | 7 compressor |
| 2 seal-gas supply | 8 separation-gas supply |
| 3 seal-gas filter module (Figure B.5) | 9 separation-gas filter module (Figure B.5) |
| 4 vent-gas outlet module (Figure B.15, B.16 or B.17) | 10 separation-gas inlet module |
| 5 seal-gas inlet module | |
| 6 balance line (multi-stage beam-type compressor with equalized seals) | |

- a Test valve.
 b Check valve normally furnished by purchaser.

NOTE This seal has no backup in the event of failure of the seal face.

Figure B.4 — Single dry gas seal system

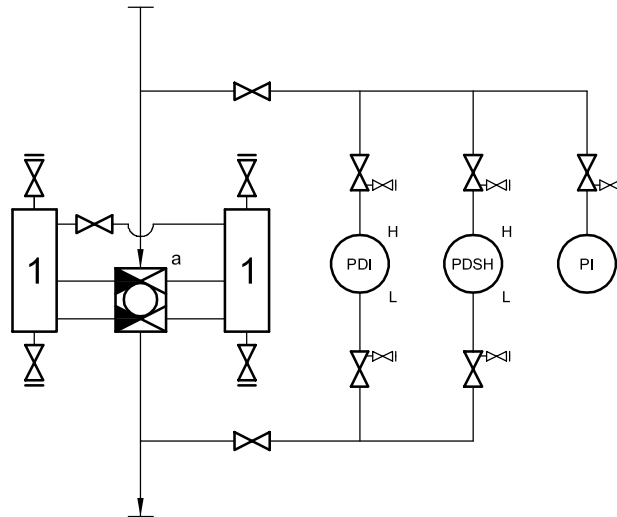

Key

- 1 filter
 a See Figure B.7 for arrangement with block valves instead of a transfer valve.

Figure B.5 — Filter module

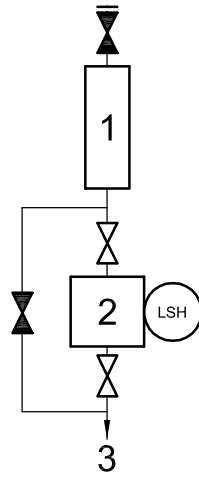

- Key**
- 1 condensing filter
 - 2 float trap
 - 3 drain

Figure B.6 — Automatic liquid-drainer system for coalescing gas filters

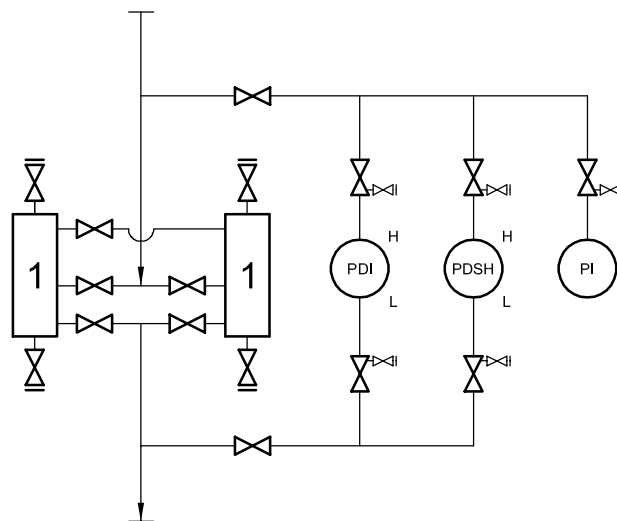

- Key**
- 1 filter

NOTE See Figure B.5 for arrangement with transfer valve.

Figure B.7 — Filter module with individual block valves substituted for transfer valve

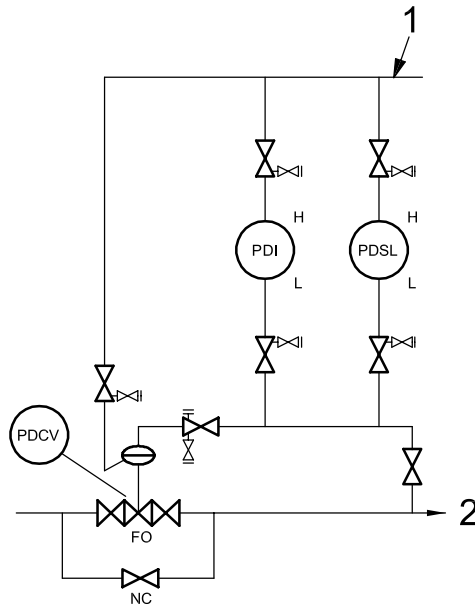

Key

- 1 seal-gas reference pressure at balance piston chamber
- 2 to seals

Figure B.8 — Differential-pressure control

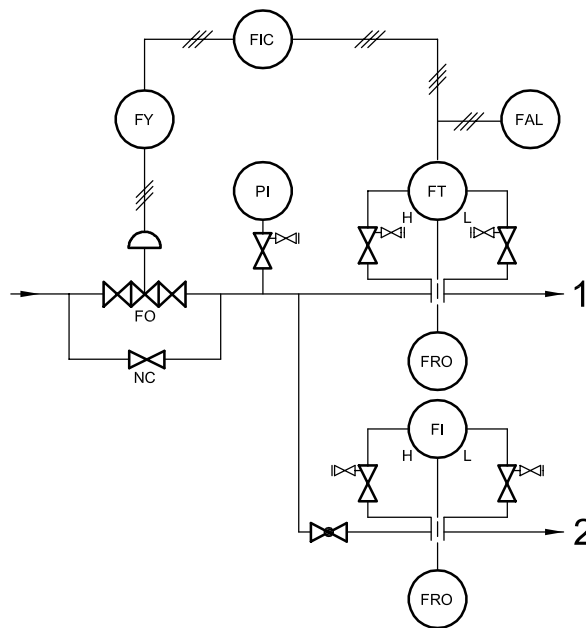

Key

- 1 to discharge end seal
- 2 to inlet end seal

Figure B.9 — Flow-control arrangement 1

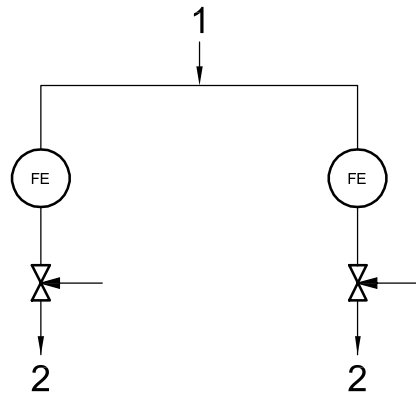

- Key**
- 1 seal-gas supply
 - 2 to each compressor end seal

Figure B.10 — Flow-control arrangement 2

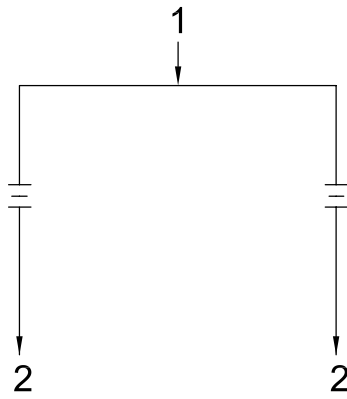

- Key**
- 1 seal-gas supply
 - 2 to each compressor end seal

Figure B.11 — Flow-control arrangement 3

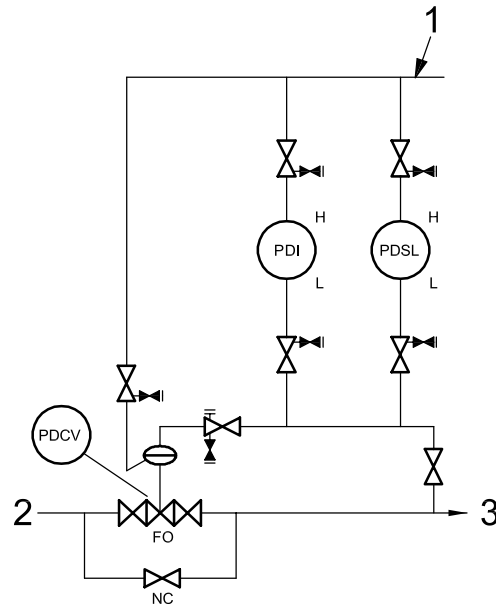

Key

- 1 primary vent
- 2 seal-gas supply
- 3 to seals

Figure B.12 — Differential-pressure control

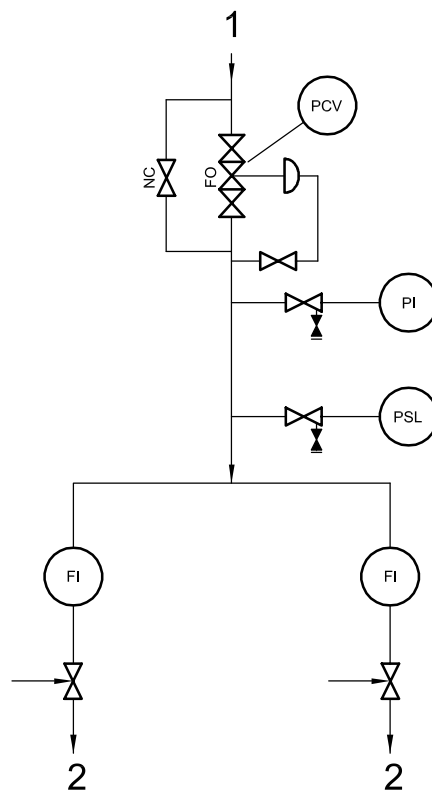

Key

- 1 seal-gas supply
- 2 to each compressor seal

Figure B.13 — Flow-control arrangement 1

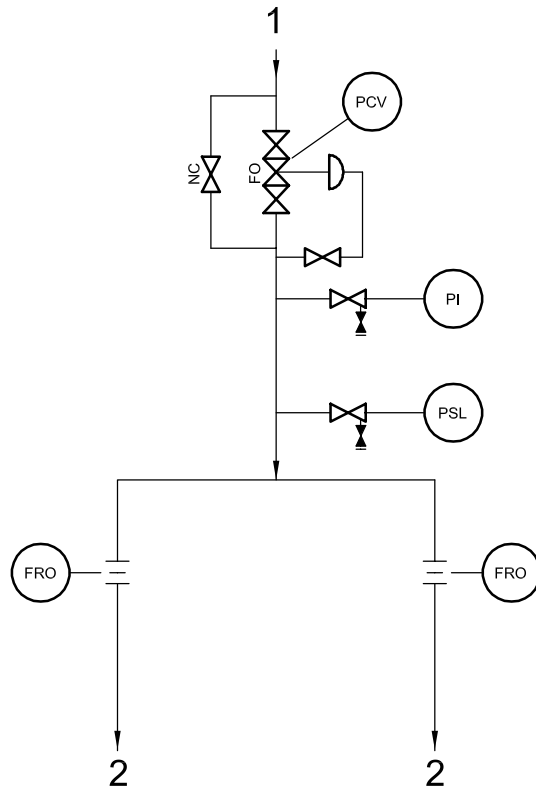

Key

- 1 seal-gas supply
- 2 to compressor

Figure B.14 — Flow-control arrangement 2

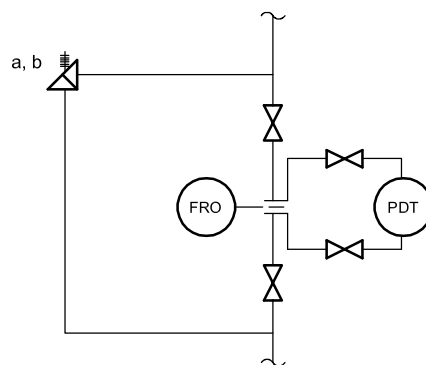

- a When over-pressure protection is required for the system, a relief device shall be provided.
- b Relief valve shown; rupture disk may be substituted.

Figure B.15 — Flow measured by differential pressure

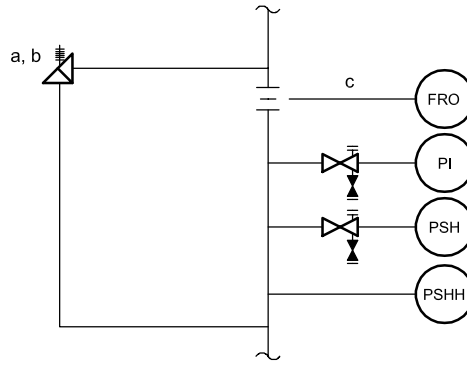

- a When over-pressure protection is required for the system, a relief device should be provided.
- b Relief valve shown; rupture disk may be substituted.
- c This option is not for use when high back-pressure can cause false shutdowns.

Figure B.16 — Flow monitored by back-pressure

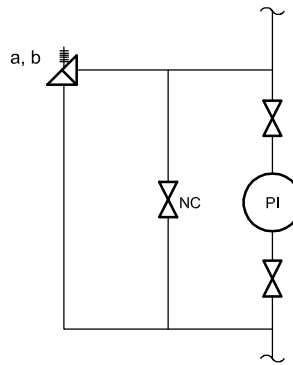

- a When over-pressure protection is required for the system, a relief device should be provided.
- b Relief valve shown; rupture disk may be substituted.

Figure B.17— Flow measuring

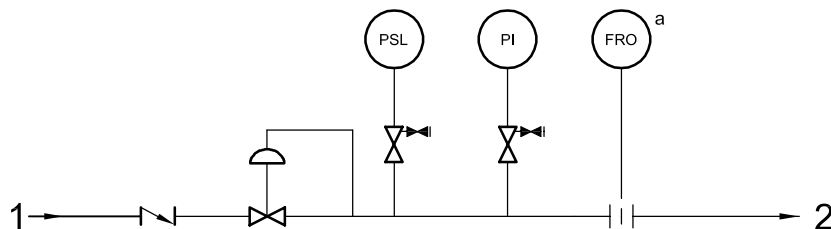

Key

- 1 separation-gas supply
- 2 to compressor
- a It is necessary that the FRO be properly sized to regulate flow through the seal.

Figure B.18— Separation-gas module (arrangement 1) — Buffered labyrinth with a remote vent

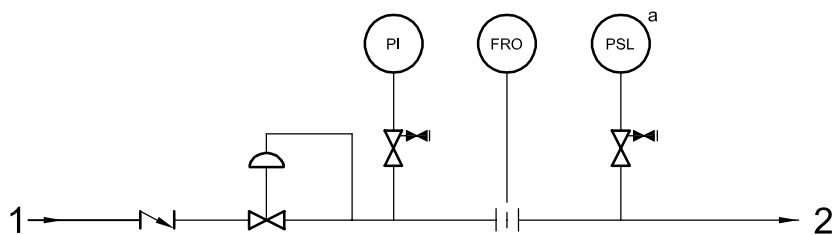

Key

- 1 separation-gas supply
- 2 to compressor

^a Flow is regulated by the relatively tight circumferential seal. PSL is arranged to sense plugging of FRO as well as loss of separation gas.

Figure B.19 — Separation-gas modules (arrangement 2) — Buffered circumferential seal with a remote vent

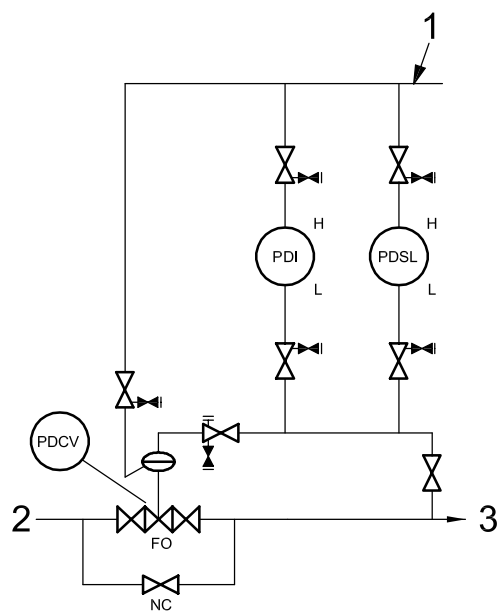

Key

- 1 seal-gas reference pressure or flare-gas back-pressure
- 2 separation-gas supply
- 3 to separation seals

Figure B.20 — Separation-gas module (arrangement 3)

Annex C (informative)

Inspector's checklist

Table C.1 — Inspector's checklist

Item	Date inspected	Inspected by	Status
1) Datasheets for system specification complete (4.1)			
In accordance with purchase order (4.1)			
2) Specified operating conditions provided (4.2.3)			
3) Test gas specified			
4) Seal-gas flow range in accordance with 4.2.6			
5) All temperature controls working in accordance with 4.2.7			
6) Valved vents, drains and piping furnished to permit draining, cleaning and refilling (4.2.9)			
7) Seal-gas module can be drained manually (4.2.10):			
a In accordance with drawings			
b Providing adequate clearances			
c Providing safe access			
8) Double block and bleeds as required (4.2.11):			
a Coolers			
b Filters			
c Other			
9) Pressure vessels in accordance with specified pressure design code (4.2.12)			
All code stamp requirements identified and supplied if required			
10) Test acceptance criteria identified (4.2.13)			
11) Backup gas test requirements specified (4.2.14)			
12) Block valves in accordance with 4.2.15			
13) Support structure stainless or carbon steel, painted (4.2.16)			
14) Verify correct filter elements installed (4.3)			
Filter housing stainless steel (4.3.1.5)			
15) Transfer valve total shutoff (4.4.1)			
Transfer valve material (4.4.2)			
16) Condensate traps (4.5)			
Drain lines for traps manifolded with flange (4.5.7)			
17) Low-point drain valves (4.5.5)			
18) All connections for piping on module flanged (5.1)			
Module interface flanges supported from the module structure (5.1)			

Table C.1 (continued)

Item	Date inspected	Inspected by	Status
19) Gas flow line material (5.2, 5.3)			
20) Control valve material (5.5)			
21) Threaded connections (5.6)			
22) Instrumentation (6.1)			
23) Alarms furnished and mounted (6.2.1)			
Functional test of alarm and shutdown setpoints (6.2.3)			
24) Flow indicators supplied as required (6.3.1)			
25) Relief valves (6.3.2)			
Steel bodies (6.3.2.3)			
26) Rupture disks (6.3.3)			
27) General inspection (7.2)			
28) Testing (7.3)			
a Operational test (7.3.3)			
b Cleanliness test (7.3.3.3)			
c Functional tests (7.3.3.4)			
29) Preparation for shipment (7.4)			
30) Spare parts (8.2)			

Annex D (informative)

Dry-gas-seal connection terminology and configurations

The following figures show common configurations of dry gas seals along with terminology associated with the connections. For detailed definitions of the seal connection terminology used, refer to the definitions in ISO 10438-1.

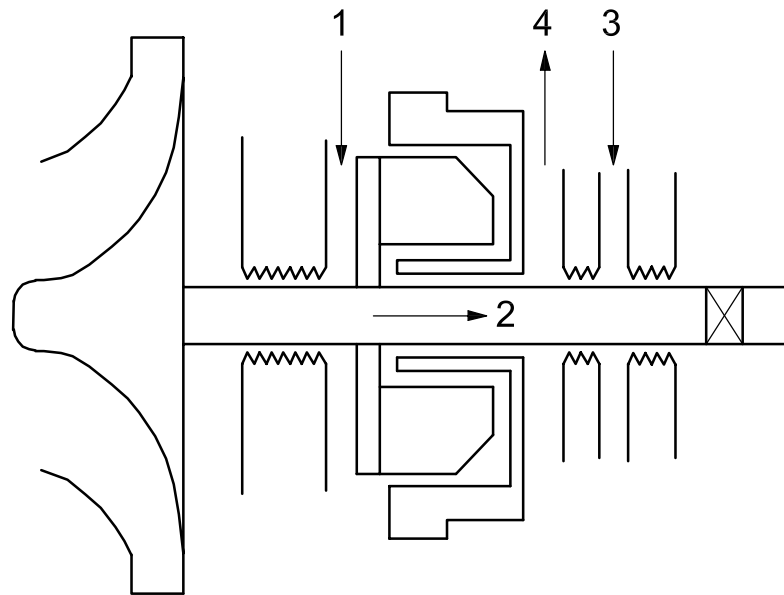

Key

- 1 seal-gas supply
- 2 seal-gas leakage
- 3 separation gas
- 4 vent gas

Figure D.1 — Single

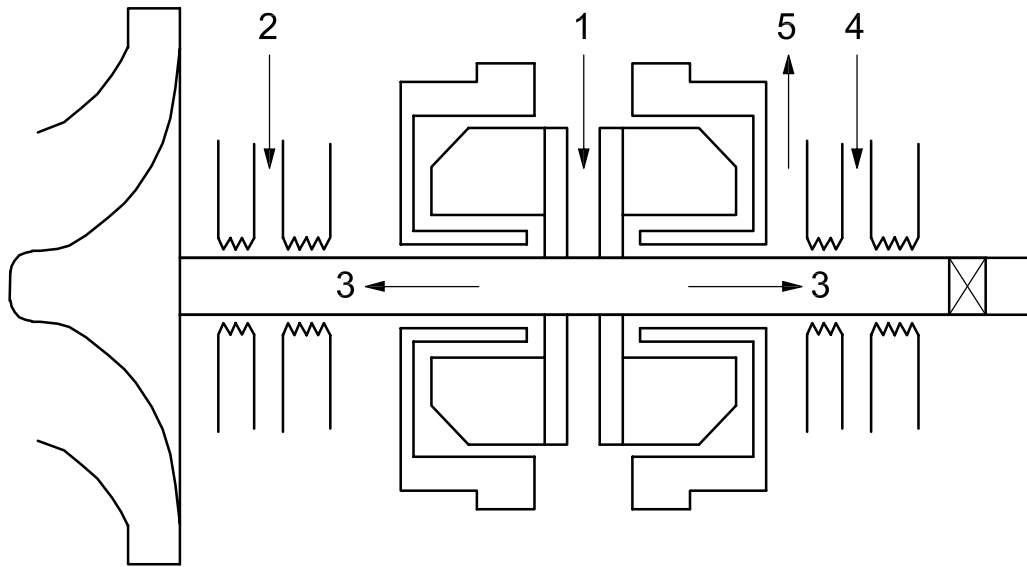

Key

- 1 seal-gas supply
- 2 seal-buffer gas
- 3 seal-gas leakage
- 4 separation gas
- 5 vent gas

Figure D.2 — Double

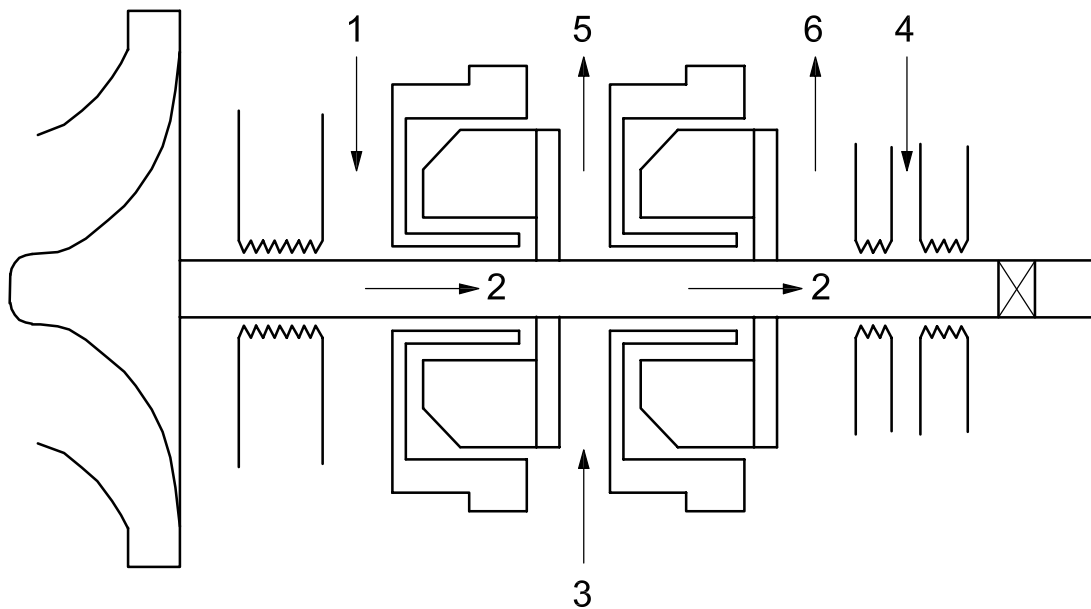

Key

- | | |
|---------------------------------|----------------------|
| 1 seal-gas supply | 4 separation gas |
| 2 seal-gas leakage | 5 primary vent gas |
| 3 secondary seal gas (optional) | 6 secondary vent gas |

Figure D.3 — Tandem

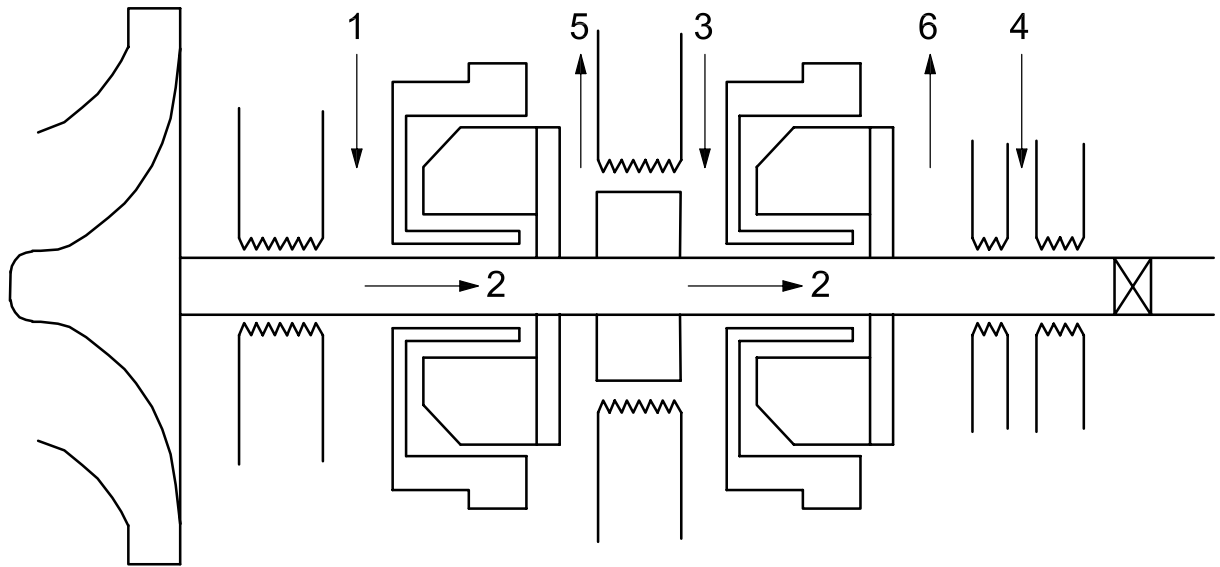
**Key**

- 1 seal-gas supply
- 2 seal-gas leakage
- 3 secondary seal gas
- 4 separation gas
- 5 primary vent gas
- 6 secondary vent gas

Figure D.4 — Tandem with intermediate labyrinth seal

Bibliography

- [1] ISO 10439, *Petroleum, chemical and gas service industries — Centrifugal compressors*
- [2] ISO 10440-1, *Petroleum, petrochemical and natural gas industries — Rotary-type positive-displacement compressors — Part 1: Process compressors*
- [3] API STD 614, *Lubrication, Shaft-Sealing, and Control-Oil Systems and Auxiliaries for Petroleum, Chemical and Gas Industry Services*
- [4] API STD 617, *Axial and Centrifugal Compressors and Expander-compressors for Petroleum, Chemical and Gas Industry Services*
- [5] API STD 619, *Rotary-Type Positive-Displacement Compressors for Petroleum, Petrochemical, and Natural Gas Industries*

BSI — British Standards Institution

BSI is the independent national body responsible for preparing British Standards. It presents the UK view on standards in Europe and at the international level. It is incorporated by Royal Charter.

Revisions

British Standards are updated by amendment or revision. Users of British Standards should make sure that they possess the latest amendments or editions.

It is the constant aim of BSI to improve the quality of our products and services. We would be grateful if anyone finding an inaccuracy or ambiguity while using this British Standard would inform the Secretary of the technical committee responsible, the identity of which can be found on the inside front cover.
Tel: +44 (0)20 8996 9000. Fax: +44 (0)20 8996 7400.

BSI offers members an individual updating service called PLUS which ensures that subscribers automatically receive the latest editions of standards.

Buying standards

Orders for all BSI, international and foreign standards publications should be addressed to Customer Services. Tel: +44 (0)20 8996 9001.
Fax: +44 (0)20 8996 7001. Email: orders@bsi-global.com. Standards are also available from the BSI website at <http://www.bsi-global.com>.

In response to orders for international standards, it is BSI policy to supply the BSI implementation of those that have been published as British Standards, unless otherwise requested.

Information on standards

BSI provides a wide range of information on national, European and international standards through its Library and its Technical Help to Exporters Service. Various BSI electronic information services are also available which give details on all its products and services. Contact the Information Centre.
Tel: +44 (0)20 8996 7111. Fax: +44 (0)20 8996 7048. Email: info@bsi-global.com.

Subscribing members of BSI are kept up to date with standards developments and receive substantial discounts on the purchase price of standards. For details of these and other benefits contact Membership Administration.
Tel: +44 (0)20 8996 7002. Fax: +44 (0)20 8996 7001.
Email: membership@bsi-global.com.

Information regarding online access to British Standards via British Standards Online can be found at <http://www.bsi-global.com/bsonline>.

Further information about BSI is available on the BSI website at <http://www.bsi-global.com>.

Copyright

Copyright subsists in all BSI publications. BSI also holds the copyright, in the UK, of the publications of the international standardization bodies. Except as permitted under the Copyright, Designs and Patents Act 1988 no extract may be reproduced, stored in a retrieval system or transmitted in any form or by any means – electronic, photocopying, recording or otherwise – without prior written permission from BSI.

This does not preclude the free use, in the course of implementing the standard, of necessary details such as symbols, and size, type or grade designations. If these details are to be used for any other purpose than implementation then the prior written permission of BSI must be obtained.

Details and advice can be obtained from the Copyright & Licensing Manager.
Tel: +44 (0)20 8996 7070. Fax: +44 (0)20 8996 7553.
Email: copyright@bsi-global.com.