

# Petroleum and natural gas industries — Cements and materials for well cementing —

## Part 2: Testing of well cements

The European Standard EN ISO 10426-2:2003, incorporating amendment A1:2005, has the status of a British Standard

ICS 75.020; 91.100.10

## National foreword

This British Standard is the UK implementation of EN ISO 10426-2:2003, incorporating amendment A1:2005 and corrigendum July 2007. It is identical with ISO 10426-2:2003, incorporating amendment 1:2005 and corrigendum June 2006.

The start and finish of text introduced or altered by corrigendum is indicated in the text by tags **AC** **AC**. Text altered by ISO corrigendum June 2006 is indicated in the text by **AC1** **AC1**.

The start and finish of text introduced or altered by ISO amendment is indicated in the text by tags **A1** **A1**. Tags indicating changes to ISO text carry the number of the ISO amendment. For example, text altered by ISO amendment 1 is indicated by **A1** **A1**.

The UK participation in its preparation was entrusted by Technical Committee PSE/17, Materials and equipment for petroleum, petrochemical and natural gas industries, to Subcommittee PSE/17/-/3, Drilling and completion fluids and well cements.

A list of organizations represented on this subcommittee can be obtained on request to its secretary.

For additional explanatory information please see the National Annex NA at the end of this standard.

This publication does not purport to include all the necessary provisions of a contract. Users are responsible for its correct application.

**Compliance with a British Standard cannot confer immunity from legal obligations.**

### Amendments issued since publication

Amd. No.	Date	Comments
15965	March 2006	See national foreword
17384 Corrigendum No. 1	31 October 2007	See national foreword

This British Standard was published under the authority of the Standards Policy and Strategy Committee on 16 January 2004

© BSI 2007

English version

**Petroleum and natural gas industries - Cements and materials  
for well cementing - Part 2: Testing of well cements  
(ISO 10426-2:2003)**

Industries du pétrole et du gaz naturel - Ciments et  
matériaux pour la cimentation des puits - Partie 2: Essais  
de ciments pour puits (ISO 10426-2:2003)

Erdöl- und Erdgasindustrie - Zemente und Materialien für  
die Zementation von Tiefbohrungen - Teil 2: Prüfungen für  
Bohrloch-Zemente (ISO 10426-2:2003)

This European Standard was approved by CEN on 1 October 2003.

CEN members are bound to comply with the CEN/CENELEC Internal Regulations which stipulate the conditions for giving this European Standard the status of a national standard without any alteration. Up-to-date lists and bibliographical references concerning such national standards may be obtained on application to the Management Centre or to any CEN member.

This European Standard exists in three official versions (English, French, German). A version in any other language made by translation under the responsibility of a CEN member into its own language and notified to the Management Centre has the same status as the official versions.

CEN members are the national standards bodies of Austria, Belgium, Cyprus, Czech Republic, Denmark, Estonia, Finland, France, Germany, Greece, Hungary, Iceland, Ireland, Italy, Latvia, Lithuania, Luxembourg, Malta, Netherlands, Norway, Poland, Portugal, Slovakia, Slovenia, Spain, Sweden, Switzerland and United Kingdom.



EUROPEAN COMMITTEE FOR STANDARDIZATION  
COMITÉ EUROPÉEN DE NORMALISATION  
EUROPÄISCHES KOMITEE FÜR NORMUNG

**Management Centre: rue de Stassart, 36 B-1050 Brussels**

## Foreword

This document (EN ISO 10426-2:2003) has been prepared by Technical Committee ISO/TC 67 "Materials, equipment and offshore structures for petroleum and natural gas industries" in collaboration with Technical Committee CEN/TC 12 "Materials, equipment and offshore structures for petroleum and natural gas industries", the secretariat of which is held by AFNOR.

This European Standard shall be given the status of a national standard, either by publication of an identical text or by endorsement, at the latest by April 2004, and conflicting national standards shall be withdrawn at the latest by April 2004.

According to the CEN/CENELEC Internal Regulations, the national standards organizations of the following countries are bound to implement this European Standard: Austria, Belgium, Czech Republic, Denmark, Finland, France, Germany, Greece, Hungary, Iceland, Ireland, Italy, Luxembourg, Malta, Netherlands, Norway, Portugal, Slovakia, Spain, Sweden, Switzerland and the United Kingdom.

**NOTE FROM CMC** The foreword is susceptible to be amended on reception of the German language version. The confirmed or amended foreword, and when appropriate, the normative annex ZA for the references to international publications with their relevant European publications will be circulated with the German version.

### Endorsement notice

The text of ISO 10426-2:2003 has been approved by CEN as EN ISO 10426-2:2003 without any modifications.

## Foreword to amendment A1

This document (EN ISO 10426-2:2003/A1:2005) has been prepared by Technical Committee ISO/TC 67 "Materials, equipment and offshore structures for petroleum and natural gas industries" in collaboration with Technical Committee CEN/TC 12 "Materials, equipment and offshore structures for petroleum and natural gas industries", the secretariat of which is held by AFNOR.

This European Standard shall be given the status of a national standard, either by publication of an identical text or by endorsement, at the latest by March 2006, and conflicting national standards shall be withdrawn at the latest by March 2006.

According to the CEN/CENELEC Internal Regulations, the national standards organizations of the following countries are bound to implement this European Standard: Austria, Belgium, Cyprus, Czech Republic, Denmark, Estonia, Finland, France, Germany, Greece, Hungary, Iceland, Ireland, Italy, Latvia, Lithuania, Luxembourg, Malta, Netherlands, Norway, Poland, Portugal, Slovakia, Slovenia, Spain, Sweden, Switzerland and United Kingdom.

### Endorsement notice

The text of ISO 10426-2:2003 has been approved by CEN as EN ISO 10426-2:2003/A1:2005 without any modifications.

INTERNATIONAL  
STANDARD

ISO  
10426-2

First edition  
2003-10-15

---

---

**Petroleum and natural gas industries —  
Cements and materials for well  
cementing —**

Part 2:  
**Testing of well cements**

*Industries du pétrole et du gaz naturel — Ciments et matériaux pour la  
cimentation des puits —*

*Partie 2: Essais de ciment pour puits*



Reference number  
ISO 10426-2:2003(E)



# Contents

Page

Foreword .....	vi
Introduction .....	vii
1 Scope .....	1
2 Normative references .....	1
3 Terms, definitions and symbols .....	1
3.1 Terms and definitions .....	1
3.2 Symbols .....	7
4 Sampling .....	8
4.1 General .....	8
4.2 Sampling cement at field location .....	8
4.3 Sampling cement blends at field location .....	8
4.4 Sampling dry cement additives at field location .....	8
4.5 Sampling liquid cement additives at field location .....	8
4.6 Sampling mixing water .....	8
4.7 Shipping and storage .....	10
4.8 Sample preparation prior to testing .....	10
4.9 Sample disposal .....	10
5 Preparation of slurry .....	10
5.1 General .....	10
5.2 Apparatus .....	10
5.3 Procedure .....	12
6 Determination of slurry density .....	14
6.1 Preferred apparatus .....	14
6.2 Calibration .....	14
6.3 Procedure .....	14
6.4 Alternative apparatus and procedure .....	16
7 Well-simulation compressive strength tests .....	16
7.1 General .....	16
7.2 Sampling .....	16
7.3 Preparation of slurry .....	17
7.4 Apparatus .....	17
7.5 Procedure .....	18
7.6 Determination of cement compressive strength at the top of long cement columns .....	20
8 Non-destructive sonic testing of cement .....	26
8.1 General .....	26
8.2 Apparatus .....	26
8.3 Sampling .....	26
8.4 Preparation of slurry .....	26
8.5 Procedure .....	26
8.6 Curing time .....	26
8.7 Curing schedules .....	26
8.8 Data reporting .....	27
9 Well-simulation thickening-time tests .....	27
9.1 General .....	27
9.2 Apparatus and material .....	27
9.3 Calibration .....	28
9.4 Test procedure .....	30

9.5	Determination of test schedule .....	32
10	Static fluid-loss tests .....	38
10.1	General .....	38
10.2	Apparatus .....	38
10.3	Safety .....	39
10.4	Mixing procedure .....	39
10.5	Conditioning procedures .....	39
10.6	Procedures for testing at temperatures $\leq 88$ °C (190 °F) .....	39
10.7	Procedures for testing at temperatures $> 88$ °C (190 °F) .....	40
10.8	Filling the static fluid-loss cell .....	42
10.9	Fluid loss test .....	43
10.10	Test completion and clean-up .....	43
11	Permeability tests .....	45
11.1	General .....	45
11.2	Apparatus .....	45
11.3	Sample preparation .....	46
11.4	Liquid permeability (cement permeameter) .....	46
11.5	Alternative procedure (core permeameter) for liquid permeability .....	47
11.6	Calculating liquid permeability .....	50
11.7	Gas permeability (core permeameter) .....	50
11.8	Calculating gas permeability .....	51
12	Determination of rheological properties and gel strength using a rotational viscometer .....	52
12.1	General .....	52
12.2	Apparatus .....	52
12.3	Calibration .....	54
12.4	Determination of rheological properties .....	54
12.5	Determination of gel strength .....	56
12.6	Modelling of the rheological behaviour .....	57
13	Calculation of pressure drop and flow regime for cement slurries in pipes and annuli .....	65
13.1	General .....	65
13.2	Newtonian fluids .....	67
13.3	Power Law fluids .....	71
13.4	Bingham Plastic fluids .....	77
13.5	Conversion factors .....	87
14	Test procedure for arctic cementing slurries .....	87
14.1	General .....	87
14.2	Preparation of cement slurry .....	87
14.3	Fluid fraction .....	87
14.4	Thickening time .....	87
14.5	Compressive strength .....	87
14.6	Freeze-thaw cycling at atmospheric pressure .....	88
14.7	Compressive strength cyclic testing .....	88
15	Well-simulation slurry stability tests .....	88
15.1	Introduction .....	88
15.2	Slurry mixing .....	89
15.3	Slurry conditioning .....	89
15.4	Free-fluid test with heated static period .....	89
15.5	Free-fluid test with ambient temperature static period .....	90
15.6	Sedimentation test .....	90
16	Compatibility of wellbore fluids .....	94
16.1	General .....	94
16.2	Preparation of test fluids .....	94
16.3	Rheology .....	95
16.4	Thickening time .....	95
16.5	Compressive strength .....	95
16.6	Solids suspension and static gel strength .....	95



16.7	Fluid loss.....	95
16.8	Water-wetting capability test (WWCT) .....	95
17	Pozzolans .....	98
17.1	General .....	98
17.2	Types of pozzolan .....	98
17.3	Physical and chemical properties .....	98
17.4	Slurry calculations .....	99
17.5	Bulk volume of a blend.....	100
Annex A	(normative) Procedure for preparation of large slurry volumes .....	102
Annex B	(normative) Calibration procedures for thermocouples, temperature-measuring systems and controllers .....	104
Annex C	(informative) Additional information relating to temperature determination.....	106
Annex D	(normative) Alternative apparatus for well thickening-time tests .....	113
Annex E	(informative) Cementing schedules .....	116
Bibliography	.....	171

## **Foreword**

ISO (the International Organisation for Standardisation) is a worldwide federation of national standards bodies (ISO member bodies). The work of preparing International Standards is normally carried out through ISO technical committees. Each member body interested in a subject for which a technical committee has been established has the right to be represented on that committee. International organisations, governmental and non-governmental, in liaison with ISO, also take part in the work. ISO collaborates closely with the International Electrotechnical Commission (IEC) on all matters of electrotechnical standardisation.

International Standards are drafted in accordance with the rules given in the ISO/IEC Directives, Part 2.

Draft International Standards adopted by the technical committees are circulated to the member bodies for voting. Publication as an International Standard requires approval by at least 75 % of the member bodies casting a vote.

Attention is drawn to the possibility that some of the elements of this document may be the subject of patent rights. ISO shall not be held responsible for identifying any or all such patent rights.

ISO 10426-2 was prepared by Technical Committee ISO/TC 67, *Materials, equipment and offshore structures for petroleum, petrochemical and natural gas industries*, Subcommittee SC 3, *Drilling and completion fluids and well cements*.

ISO 10426 consists of the following parts, under the general title *Petroleum and natural gas industries — Cements and materials for well cementing*:

- *Part 1: Specification*
- *Part 2: Testing of well cements*
- *Part 3: Testing of deepwater well cement formulations*
- *Part 4: Preparation and testing of foamed cement slurries at atmospheric pressure*

The following part is under preparation:

- *Part 5: Determination of shrinkage and expansion of well cement formulations at atmospheric pressure*

## **Foreword to amendment A1**

ISO (the International Organization for Standardization) is a worldwide federation of national standards bodies (ISO member bodies). The work of preparing International Standards is normally carried out through ISO technical committees. Each member body interested in a subject for which a technical committee has been established has the right to be represented on that committee. International organizations, governmental and non-governmental, in liaison with ISO, also take part in the work. ISO collaborates closely with the International Electrotechnical Commission (IEC) on all matters of electrotechnical standardization.

International Standards are drafted in accordance with the rules given in the ISO/IEC Directives, Part 2.

The main task of technical committees is to prepare International Standards. Draft International Standards adopted by the technical committees are circulated to the member bodies for voting. Publication as an International Standard requires approval by at least 75 % of the member bodies casting a vote.

Attention is drawn to the possibility that some of the elements of this document may be the subject of patent rights. ISO shall not be held responsible for identifying any or all such patent rights.

Amendment 1 to ISO 10426-2:2003 was prepared by Technical Committee ISO/TC 67, *Materials, equipment and offshore structures for petroleum, petrochemical and natural gas industries*, Subcommittee SC 3, *Drilling and completion fluids and well cements*.

## **Introduction**

This part of ISO 10426 is based on API RP 10B, 22nd edition, December 1997, addendum 1, October 1999.

Users of this part of ISO 10426 should be aware that further or differing requirements may be needed for individual applications. This part of ISO 10426 is not intended to inhibit a vendor from offering, or the purchaser from accepting, alternative equipment or engineering solutions for the individual application. This may be particularly applicable where there is innovative or developing technology. Where an alternative is offered, the vendor should identify any variations from this part of ISO 10426 and provide details.

In this part of ISO 10426, where practical, US Customary units are included in brackets for information.

Well cement classes and grades are defined in ISO 10426-1.



# Petroleum and natural gas industries — Cements and materials for well cementing —

## Part 2: Testing of well cements

### 1 Scope

This part of ISO 10426 specifies requirements and gives recommendations for the testing of cement slurries and related materials under simulated well conditions.

### 2 Normative references

The following referenced documents are indispensable for the application of this document. For dated references, only the edition cited applies. For undated references, the latest edition of the referenced document (including any amendments) applies.

ISO 10414-1, *Petroleum and natural gas industries — Field testing of drilling fluids — Part 1: Water-based fluids*

API RP 13J, *Testing of heavy brines (second edition), March 1996*

ASTM C 109, *Standard test method for compressive strength of hydraulic cement mortars (using 2 in. or [50 mm] cube specimens)*

ASTM C 188, *Standard test method for density of hydraulic cement*

### 3 Terms, definitions and symbols

#### 3.1 Terms and definitions

For the purposes of this document, the following terms and definitions apply.

##### 3.1.1

##### **absolute volume**

reciprocal of absolute density

NOTE It is expressed as volume per unit mass.

##### 3.1.2

##### **additive**

material added to a cement slurry to modify or enhance some desired property

NOTE Common properties that are modified include: setting time (by use of retarders or accelerators), fluid loss control, viscosity, etc.

**3.1.3**

**annulus**

space surrounding the pipe in the wellbore

NOTE The outer wall of the annular space may be either surface or casing

**3.1.4**

**assumed surface temperature**

$T_{AS}$

assumed temperature at surface used for calculating a pseudo-temperature gradient

**3.1.5**

**batch mixing**

process of mixing and holding a volume of cement slurry prior to placement in the wellbore

**3.1.6**

**Bearden units of consistency**

units used to express consistency of a cement slurry when determined on a pressurized consistometer

NOTE The symbol for consistency when expressed in Bearden units is  $B_c$ .

**3.1.7**

**blowout**

point in time at which nitrogen flows through the sample in a fluid loss test

**3.1.8**

**bulk density**

mass per unit volume of a dry material containing entrained air

**3.1.9**

**casing cementing**

complete or partial annular cementing of a full casing string

**3.1.10**

**cement**

**Portland cement**

ground clinker generally consisting of hydraulic calcium silicates and aluminates and usually containing one or more of the forms of calcium sulfate as an interground addition

NOTE 1 Hydraulic calcium silicates and aluminates are those which harden under water.

NOTE 2 Interground additions are added before grinding, rather than after grinding.

**3.1.11**

**cement class**

**cement type**

designation achieved using the ISO system of classifications of well cement in accordance with its intended use

NOTE See ISO 10426-1 for further information.

**3.1.12**

**cement grade**

designation achieved using the ISO system for denoting the sulfate resistance of a particular cement

NOTE See ISO 10426-1 for further information.

**3.1.13****cement blend**

mixture of dry cement and other dry materials

**3.1.14****clinker**

fused materials from the kiln in cement manufacturing that are interground with calcium sulfate to make cement

**3.1.15****compatibility**

capacity to form a fluid mixture that does not undergo undesirable chemical and/or physical reactions

**3.1.16****compressive strength**

strength of a set cement sample measured by the force required to crush it

NOTE It is expressed as force per unit area.

**3.1.17****consistometer**

device used to measure the thickening time of a cement slurry under specified temperature and pressure

**3.1.18****continuous-pumping squeeze-cementing operation**

squeeze-cementing operation that does not involve cessation of pumping

**3.1.19****equivalent sack**

mass of the blend of Portland cement and fly ash or pozzolan that has the same absolute volume as 42,63 kg (94 lbs) of Portland cement

**3.1.20****filtrate**

liquid that is forced out of a cement slurry during a fluid loss test

**3.1.21****fly ash**

powdered residue from the combustion of coal having pozzolanic properties

NOTE See Clause 17 for further description.

**3.1.22****free fluid**

coloured or colourless liquid which has separated from a cement slurry

**3.1.23****freeze-thaw cycle**

test involving a cement sample that is alternately exposed to temperatures above and below the freezing point of water

**3.1.24****hesitation-pumping squeeze-cementing operation**

squeeze-cementing operation that incorporates discontinuous pumping of the cement slurry

NOTE The slurry is placed into the well, the pumps are stopped for some period of time, then a volume of slurry is again pumped. The process is repeated until a predetermined pressure is reached or the volume of cement slurry has been completely pumped.

**3.1.25**

**heat-up rate**

$R_h$   
rate of slurry temperature change on going from the surface temperature,  $T_{SS}$ , to the predicted bottom-hole circulating temperature,  $T_{PBHC}$

**3.1.26**

**liner cementing**

annular cementing operations for which the top of the casing being cemented is not at the top the wellbore

**3.1.27**

**mud**

fluid that is circulated through the wellbore during drilling or workover operations

**3.1.28**

**mud balance**

beam-type balance used to measure fluid density at atmospheric pressure

**3.1.29**

**neat cement slurry**

cement slurry consisting of only cement and water

**3.1.30**

**pressure-down rate**

$R_{pd}$   
rate at which pressure is reduced from the bottom-hole pressure,  $p_{BH}$ , to the pressure at the top of cement column,  $p_{TOC}$ , during a thickening-time test

**3.1.31**

**permeability**

measure of the capacity of a porous medium to allow flow of fluids or gases

NOTE Permeability is usually expressed in millidarcy, mD.

**3.1.32**

**plug cementing**

process of placing a volume of cement in a well to form a plug across the wellbore

**3.1.33**

**pozzolan**

siliceous or siliceous and aluminous material which in finely divided form reacts with calcium hydroxide to form a cementitious material

NOTE See Clause 17 for further description.

**3.1.34**

**preflush**, noun

fluid containing no insoluble weighting agents used to separate drilling fluids and cementing slurries

**3.1.35**

**pressure vessel**

vessel in a consistometer into which the slurry container is placed for the thickening-time test

**3.1.36**

**pressurized curing vessel**

vessel used for curing a sample of cement under temperature and pressure for compressive strength testing



**3.1.37****pressure-up rate** $R_{pu}$ 

rate at which pressure is increased from the starting pressure to the bottom-hole pressure during a thickening-time test

**3.1.38****relative density****specific gravity**

ratio of the mass of a substance to the mass of an equal volume of a standard substance at a reference temperature

NOTE The standard substance is usually water; the reference temperature is usually 4 °C.

**3.1.39****sedimentation**

separation and settling of solids in a cement slurry

**3.1.40****slurry container**

container in a pressurized consistometer used to hold the slurry for conditioning purposes or for thickening-time test

**3.1.41****sonic strength**

extent of strength development of a cement sample calculated by measuring the velocity of sound through it

NOTE The calculation is based on specific mathematical correlations and not on direct measurements of strength.

**3.1.42****starting pressure** $p_S$ 

initial pressure applied to the test sample at the beginning of the thickening-time test

NOTE  $p_S$  is also used to determine the pressure-up rate.

**3.1.43****spacer**

fluid containing insoluble weighting materials that is used to separate drilling fluids and cementing slurries

**3.1.44****squeeze-cementing**

remedial process in which cementing material is forced under pressure into a specific portion of the well such as a fracture or opening

**3.1.45****static fluid loss test**

test to determine fluid lost from a cement slurry when placed against a 325 mesh screen at 6 900 kPa (1 000 psi) differential pressure

**3.1.46****static stability test**

test to determine the degree of sedimentation and free fluid development in a cement slurry

**3.1.47****stirred fluid-loss cell**

cell specially designed to allow for conditioning of the cement slurry within the same cell used to perform a static fluid loss test

**3.1.48**

**strength retrogression**

reduction in compressive strength and increase in permeability of a cement caused by exposure to temperatures exceeding 110 °C (230 °F)

**3.1.49**

**thickening time**

time required for a cement slurry to develop a selected Bearden consistency value

NOTE The results of a thickening-time test provide an indication of the length of time a cement slurry can remain pumpable under the test conditions.

**3.1.50**

**weigh batch mixer**

**scale tank**

device or system for the weighing and blending of cement with dry additives

**3.1.51**

**well simulation test**

test whose parameters are designed and modified as required to simulate the conditions found in a wellbore

**A1 3.1.52**

**water-wetting capability**

capability of a fluid to alter the quality or state of being water-wetted

NOTE A fully water-wet state is considered most desirable to provide cement bonding. **A1**

### 3.2 Symbols

For the purposes of this part of ISO 10426, the symbols given in Table 1 apply. This list is non-exhaustive.

**Table 1 — Symbols**

Symbol	Meaning
$h_{\text{TOCTVD}}$	top-of-cement true vertical depth
$p_{\text{BH}}$	$\langle \text{AC1} \rangle$ bottom-hole pressure <sup>a</sup> $\langle \text{AC1} \rangle$
$p_{\text{S}}$	starting pressure
$p_{\text{TOC}}$	top-of-cement pressure
$T_{\text{AS}}$	assumed surface temperature
$T_{\text{BHC}}$	$\langle \text{AC1} \rangle$ bottom-hole circulating temperature <sup>b</sup> $\langle \text{AC1} \rangle$
$T_{\text{BHS}}$	bottom-hole static temperature
$T_{\text{PBHC}}$	predicted bottom-hole circulating temperature
$T_{\text{MRBHS}}$	maximum recorded bottom-hole temperature after a static period
$T_{\text{MNRBHC}}$	minimum recorded bottom-hole temperature after sufficient circulation in the well to obtain a stabilized or steady-state temperature
$T_{\text{PS}}$	predicted squeeze temperature
$\nabla_{\text{PT}}$	pseudo-temperature gradient <sup>c</sup>
$T_{\text{PU}}$	pseudo-undisturbed temperature
$T_{\text{RS}}$	recorded squeeze temperature
$T_{\text{SS}}$	slurry surface temperature
$T_{\text{TOCC}}$	top-of-cement circulating temperature
$T_{\text{TOCS}}$	top-of-cement static temperature
$T_{\text{TOC}}$	top-of-cement column temperature
$T_{\text{UF}}$	undisturbed formation temperature
$t_{\text{a}}$	time to displace the leading edge of the cement slurry from bottom of the casing to the top of the annular cement column
$t_{\text{d}}$	time to displace the leading edge of cement slurry to the bottom of the wellbore or other predetermined location in the well

a  $\langle \text{AC1} \rangle$  Hydrostatic pressure at the bottom of the well, calculated from the true vertical depth and the fluid densities in the wellbore.

b The  $T_{\text{BHC}}$  can vary with time, fluid being circulated, pump rate, pipe size, etc.  $\langle \text{AC1} \rangle$

c Gradient in °C/100 m (°F/100 ft), calculated from the difference between the maximum recorded bottom-hole static temperature ( $T_{\text{MRBHS}}$ ) and the  $T_{\text{AS}}$ .

## 4 Sampling

### 4.1 General

For cement blends, the purpose for which samples are taken shall be considered. In many cases, samples of the cement, cement blend, solid and liquid additives, and mixing water may be required to test a slurry in accordance with this part of ISO 10426. The best available sampling technology shall be employed to ensure accurate samples are taken. Some commonly used sampling techniques are described in this clause.

NOTE API documents prior to API RP10B, 22nd Edition, December 1997 have dealt only with sampling unblended cement in accordance with the procedure outlined in ASTM C 183.

### 4.2 Sampling cement at field location

When sampling from bulk tanks, transport containers or sacks, the cement shall be dry and uniform. Multiple samples shall be extracted using a suitable device (Figure 1). A composite of the samples shall be prepared, packaged and labelled (see 4.7). Average sample volume shall be 8 l to 20 l. Suggested sampling procedures are also outlined in ASTM C 183.

### 4.3 Sampling cement blends at field location

Cement blends may be sampled from the weigh batch mixer (scale tank), bulk transport or extracted from the flow lines during transfer. The cement and dry additives shall be thoroughly blended prior to sampling. This can be done by transferring the cement (air blowing) from the weigh batch mixer to some other container three to six times. Samples from the bulk container may be extracted in accordance with 4.2. Samples extracted from a flow line during a transfer may be taken from a properly installed sample valve, diverted flow sampler or automatic in-line sampling device (Figure 1). The samples shall be prepared, packaged, and labelled (4.7). Sample volume shall be sufficient to perform the desired testing.

### 4.4 Sampling dry cement additives at field location

Dry cement additive samples may be extracted from a bulk container or sack. The additive shall be dry and uniform prior to sampling. Multiple samples shall be extracted from the centre of the source using a suitable sampling device (Figure 1). A composite of the samples from the same lot shall be prepared, packaged and labelled (4.7). The volume of each dry cement additive sample shall be sufficient to perform the desired testing.

### 4.5 Sampling liquid cement additives at field location

Most liquid additives are solutions or suspensions of dry materials. Prolonged storage can cause separation of the active ingredients. Thus, the active ingredients may float to the top of the container, be suspended as a phase layer, or settle to the bottom. For these reasons, liquid additives shall be thoroughly mixed prior to sampling. The sample shall then be extracted from the centre of the container using a clean, dry sampling device. A composite of the samples from the same lot shall be prepared, packaged and labelled (4.7). The volume of each liquid additive sample shall be sufficient to perform the desired testing.

### 4.6 Sampling mixing water

The mixing water shall be sampled from the source. The sample shall be extracted in such a way as to avoid contamination. The sample shall be packaged and labelled (4.7). The sample volume shall be sufficient to perform the desired testing.

Dimensions in millimetres

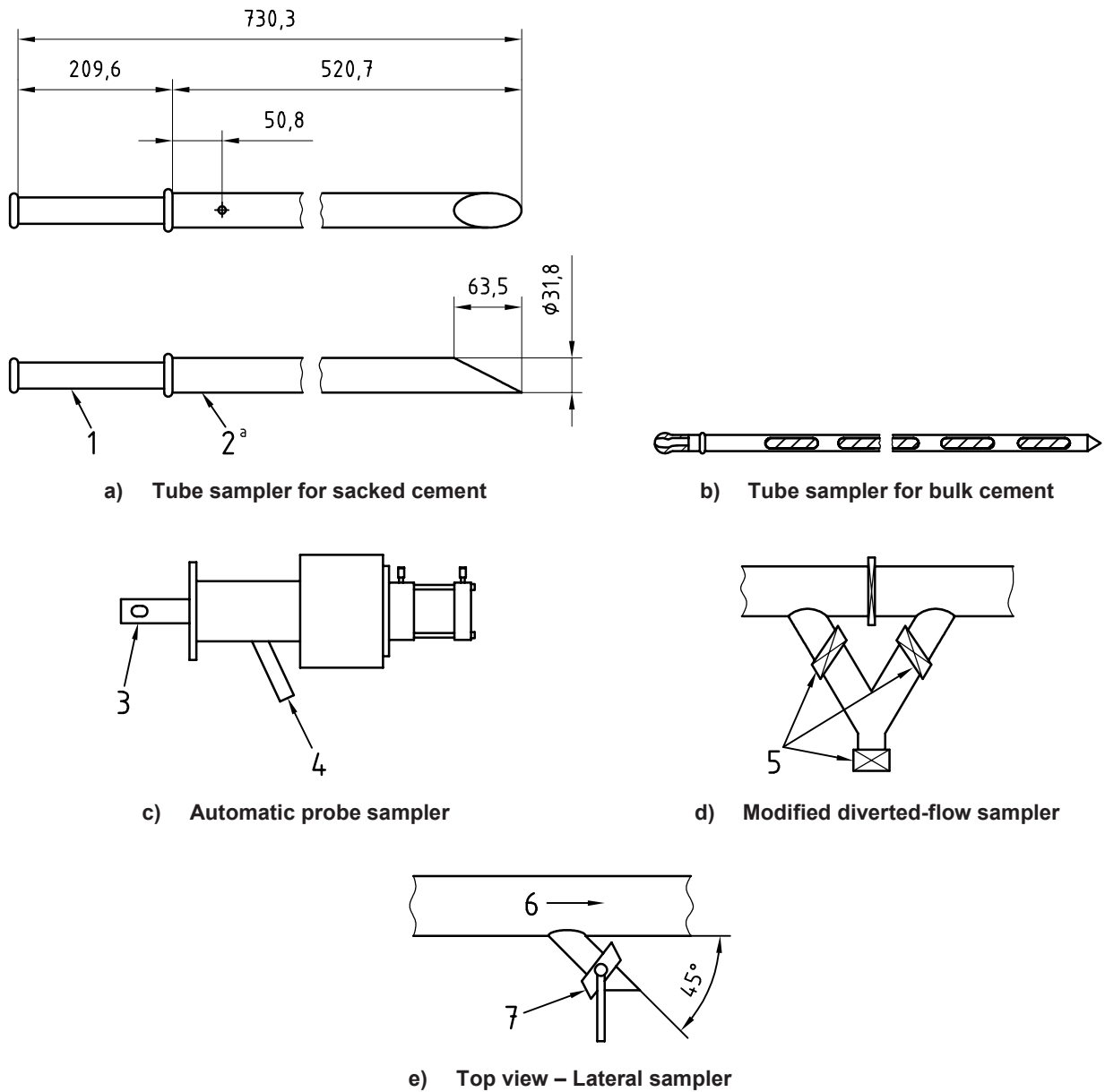

**Key**

- 1 hardwood handle
- 2 Dragg tubing
- 3 sample tube extended
- 4 product discharge
- 5 2,54 cm (1 in) ball valve
- 6 flow direction
- 7 2,54 cm (1 in) ball valve

<sup>a</sup> Approximate volume = 320 ml

**Figure 1 — Commonly used sampling devices**

#### **4.7 Shipping and storage**

Test samples shall be packaged promptly in clean, airtight, moisture-proof containers suitable for shipping and long-term storage. The containers shall be lined metal, plastic, or some other heavy-walled flexible or rigid material to assure maximum protection. Re-sealable plastic bags may be used provided the bag is placed in a protective container prior to shipping to prevent puncturing, and to contain all material that may leak out during shipping. Ordinary cloth sacks, cans or jars shall not be used. Shipping in glass containers is not recommended.

Each slurry container shall be clearly labelled and identified with the type of material, lot number, source, and date of sampling. Shipping containers shall also be labelled. The lids of containers shall not be marked, since the lids can be readily interchanged and thus lead to confusion. Any required regulatory identification or documentation shall be enclosed or securely attached to the container. All hazardous material samples shall be packaged and labelled in accordance with all regulatory requirements.

#### **4.8 Sample preparation prior to testing**

Upon arrival at the testing location the samples shall be closely examined to ensure they have remained sealed during shipment and are not contaminated. Each sample shall be thoroughly blended just prior to slurry preparation. (Clause 5)

For storage, each sample shall be transferred into a suitable, leak-proof container (if one has not been used in shipping), properly labelled and dated, and stored in a dry place where room temperatures remain fairly constant. At the time of testing, each sample shall be examined for quality and thoroughly blended just prior to slurry preparation.

Optimum shelf life(s) for all samples shall be determined by the supplier or manufacturer. If unknown, use of any cement additive that has been stored for longer than one year is not recommended.

#### **4.9 Sample disposal**

Sample disposal shall comply with all regulatory requirements.

### **5 Preparation of slurry**

#### **5.1 General**

The preparation of cement slurries varies from that of classical solid/liquid mixtures due to the reactive nature of cement. Shear rate and time at shear are important factors in the mixing of cement slurries. Varying these parameters has been shown to affect slurry performance properties.

The procedure described in this Clause is recommended for the laboratory preparation of slurries that require no special mixing conditions. If large slurry volumes are needed, the alternative method for slurry preparation given in Annex A may be used.

#### **5.2 Apparatus**

**5.2.1 Electronic balances**, with an accuracy of within  $\pm 0,1$  % of the indicated load.

Balances shall be calibrated frequently enough to ensure accuracy, and at least annually.

**5.2.2 Mechanical balances**, with weights having an accuracy within  $\pm 0,1$  % of the weight indicated.

**5.2.3 Mixing device**, of capacity 1 litre (1 quart), having bottom drive and a blade-type mixer.

Examples of mixing devices in common use for preparation of slurries are shown in Figure 2. The mixing container and the mixing blade shall be constructed of corrosion-resistant material (Figure 3). The mixing assembly shall be constructed so that the blade can be separated from the drive mechanism.

The mixing blade shall be separated from the mixing assembly and weighed prior to use and replaced with a new blade when 10 % mass loss has occurred. The blade shall also be visually inspected for damage prior to each use and replaced as necessary.

If the mixing device leaks at any time during the mixing procedure, the contents shall be discarded, the leak repaired and the procedure restarted.

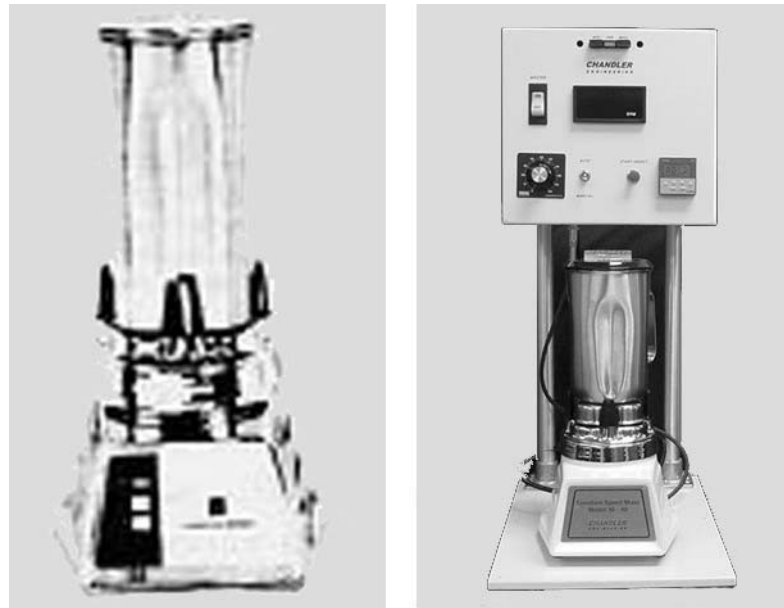
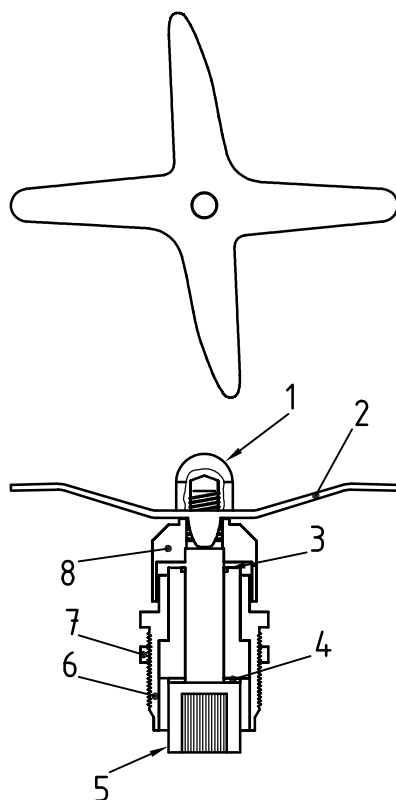

Figure 2 — Common mixing devices



**Key**

- 1 cap nut
- 2 hardened blade (installed with tapered edge down)
- 3 O-ring
- 4 thrust washer
- 5 socket head shaft
- 6 bearing holder
- 7 hexagonal nut
- 8 bearing cap

**Figure 3 — Blade assembly**

**5.3 Procedure**

**5.3.1 Determination of relative density (specific gravity) of components**

**5.3.1.1 General**

The relative density of different batches of cement can vary due to natural changes in the composition of the raw materials used in the manufacturing process. Studies have shown that cement relative density may vary from 3,10 to 3,25. This variability could result in deviation of slurry densities by as much as 0,033 kg/l for slurries with constant water-to-solids ratio. The relative density of mix water can also vary, depending on the source, resulting in slurry density inconsistencies. Determination of the relative density of all components of the slurry is necessary to properly calculate the required amounts for slurry preparation.



### 5.3.1.2 Relative density of cement and dry additives

The relative density of the cement and any dry additives may be determined by the use of a Le Chatelier flask as outlined in ASTM C 188. Alternatively, a pycnometer may be used for determining the relative density of these materials.

### 5.3.1.3 Relative density of mix water and liquid additives

The relative density of the mix water and any liquid additives shall be determined by the use of a hydrometer as outlined in API RP 13J. Alternatively, a pycnometer may be used for determining the relative density of these materials.

### 5.3.1.4 Laboratory density and volume calculations

A slurry volume of approximately 600 ml shall be sufficient to perform most laboratory test procedures while not overfilling the mixing container. Laboratory blend requirements may be calculated by use of the following formulas. Alternative, suitable equations may also be used to calculate laboratory blend requirements.

For the purpose of these calculations, assume that relative density is equal to density expressed in grams per millilitre.

$$V_s = V_c + V_w + V_a$$

$$m_s = m_c + m_w + m_a$$

$$\rho_s = m_s / V_s$$

where

$V_s$  is the slurry volume, in millilitres;

$V_c$  is the cement volume, in millilitres;

$V_w$  is the water volume, in millilitres;

$V_a$  is the additive volume, in millilitres;

$\rho_s$  is the density of slurry, in grams per millilitre;

$m_s$  is the slurry mass, in grams;

$m_c$  is the cement mass, in grams;

$m_w$  is the water mass, in grams;

$m_a$  is the additive mass, in grams;

$$V_c = m_c / \rho_c$$

where  $\rho_c$  is the density of cement, in grams per millilitre;

$$V_w = m_w / \rho_w$$

where  $\rho_w$  is the density of water, in grams per millilitre;

$$V_a = m_a / \rho_a$$

where  $\rho_a$  is the density of additive, in grams per millilitre.

### **5.3.2 Temperature of water and cement**

The temperature of the mix water, dry cement or cement blend, mixing and blending devices shall be representative of field mixing conditions. If field conditions are unknown, the temperature of the mix water and dry cement shall be  $23\text{ °C} \pm 1\text{ °C}$  ( $73\text{ °F} \pm 2\text{ °F}$ ) immediately prior to mixing. In all cases, the temperatures of the mix water and dry cement shall be measured and documented.

### **5.3.3 Mix water**

Water composition can affect slurry performance. Water from the field source shall be used. If field mix water is unavailable, a water of similar composition shall be used. If field mix water composition is unknown, deionized, distilled, or tap water may be used. The mix water and any liquid additives shall be weighed into a clean, dry, mixing container. No excess water shall be added to compensate for evaporation or wetting.

### **5.3.4 Mixing of cement and water**

Weigh dry materials and then blend thoroughly and uniformly prior to adding them to the mixing fluid. Place the mixing container with the required mass of mix water and any liquid additives on the mixer base. Turn on the motor and maintain at  $4\ 000\text{ r/min} \pm 200\text{ r/min}$  ( $66,7\text{ r/s} \pm 3,3\text{ r/s}$ ). If additives are present in the mix water, stir at the above rotational speed to thoroughly disperse them prior to the addition of cement. In certain cases, the order of addition of the additives to the mixing water can be critical. Document any special mixing procedures and mixing time. Add the cement or cement/dry additive blend at a uniform rate, in not more than 15 s if possible. Some slurry designs may take longer to completely wet the cement blend, however, the time used to add the blend shall be kept at a minimum. When all the dry materials have been added to the mix water, place the cover on the mixing container and continue mixing at  $12\ 000\text{ r/min} \pm 500\text{ r/min}$  ( $200\text{ r/s} \pm 8,3\text{ r/s}$ ) for  $35 \pm 1\text{ s}$ . Measure and document the rotational speed under load.

## **6 Determination of slurry density**

### **6.1 Preferred apparatus**

The preferred method for measuring the density of a cement slurry is by using the pressurized fluid density balance. The pressurized fluid density balance is similar in operation to the conventional mud balance, the difference being that the slurry can be placed in a fixed volume sample cup under pressure.

The purpose of placing the sample under pressure is to minimize the effect of entrained air upon slurry density measurements. A major problem found in the measurement of cement slurry densities is that often these fluids have a considerable amount of air entrained when initially mixed. By pressurizing the sample cup, any entrained air is decreased to a negligible volume, thus providing a slurry density measurement more closely in agreement with that which will be found under downhole conditions.

### **6.2 Calibration**

The calibration of the apparatus shall be verified by placing water or fluids of known density in the sample cup or by using manufacturer-specified weights for equivalent densities placed in the sample cup.

### **6.3 Procedure**

**6.3.1** The sample cup shall be filled to a level slightly below the upper edge of the cup [ $6\text{ mm} \pm 0,5\text{ mm}$  ( $1/4\text{ in}$ )].

**6.3.2** Place the lid on the cup with the check valve in the down (open) position. Push the lid downward into the mouth of the cup until surface contact is made between the outer skirt of the lid and the upper edge of the cup. Expel excess slurry through the check valve.

**CAUTION** Slurry can be expelled forcibly.

When the lid has been placed on the cup, pull the check valve up in the closed position, rinse off the cup and threads with water, and screw the threaded cap on the cup.

**6.3.3** The pressurizing pump is similar in operation to a syringe. Fill the pump by submerging the nose of the pump assembly in the slurry with the piston rod in the completely inward position. Then draw the piston rod upward, thereby filling the pump cylinder with slurry.

**6.3.4** Push the nose of the pump onto the mating O-ring surface of the check valve. Pressurize the sample cup by maintaining a downward force on the pump cylinder housing in order to hold the check valve down (open) and at the same time force the piston rod inward. Maintain approximately 230 N (50 lbf) force or greater on the piston rod, see Figure 4.

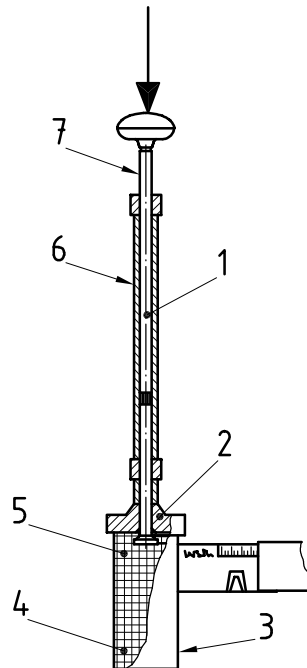

#### Key

- 1 pressurizing pump
- 2 pressurizing valve
- 3 sample cup
- 4 entrained air
- 5 slurry sample
- 6 cylinder housing
- 7 piston rod

**Figure 4 — Fluid density balance**

**6.3.5** The check valve in the lid is pressure-actuated, which means the pressure in the cup keeps the valve closed. Close the valve initially by gradually lifting the cylinder housing of the pressurizing pump while applying pressure to the piston rod. When the check valve closes, release pressure on the piston rod before disconnecting the pump.

**6.3.6** Rinse off the exterior of the cup and wipe dry. Then place the instrument on the knife edge as illustrated in Figure 5. Move the sliding weight right or left until the beam is balanced. The beam is balanced when the attached bubble is centred between the two scribed marks. Obtain the density by reading one of the four calibrated scales on the arrow side of the sliding weight.



**Figure 5 — Pressurized fluid density balance**

**6.3.7** To push the valve downward and release the pressure, reconnect the pump assembly and push downward on the pump cylinder housing.

Then empty the cup and pump assembly of its contents, and thoroughly clean all components.

For best operation, lightly grease the valve, lid and cylinder.

## **6.4 Alternative apparatus and procedure**

### **6.4.1 Alternative apparatus**

Cement slurry density may alternatively be determined by use of the mud balance.

### **6.4.2 Alternative procedure**

The procedure for using a mud balance shall be in accordance with the latest edition of ISO 10414-1 except that the slurry, after being poured into the mud balance cup, shall be puddled 25 times to eliminate entrapped air.

## **7 Well-simulation compressive strength tests**

### **7.1 General**

This clause presents procedures for well-simulation compressive strength testing. Well-simulation compressive strength tests are not required for compliance with ISO 10426-1.

The well-simulation compressive strength tests described in this clause may be used to test cements or cement blends for resistance to thermally induced strength retrogression. To do this, the cement or cement blend sample is exposed to temperature and pressure for varying periods of time and observed for changes in compressive strength. The procedure involves comparing the compressive strength observed after some initial period (such as 24 h, 48 h or 72 h) with the compressive strength observed after some extended period or periods (such as 28 d). Cements or cement blends that exhibit lower compressive strength after extended ageing may be considered to exhibit strength retrogression. The commonly cited temperature threshold for thermally induced strength retrogression is 110 °C (230 °F), although deviation from this value has been reported.

### **7.2 Sampling**

Obtain samples of the cement, additives, and mix water in accordance with Clause 4.

### 7.3 Preparation of slurry

Prepare the slurry in accordance with Clause 5.

### 7.4 Apparatus

**7.4.1 Cube moulds and compressive-strength testing machine**, conforming to the requirements of ASTM C 109, except that the moulds may be separable into more than two parts.

Moulds and testing machine for compressive strength tests shall conform to the requirements of ASTM C 109, except that the moulds may be separable into more than two parts. The mould tolerances shall be verified. Calibrate the testing device to be accurate to  $\pm 1\%$  of the load range to be measured. The moulds and testing device shall be calibrated at least every two years.

**7.4.2 Cube mould base and cover plates**, of corrosion-resistant material.

The base plate shall be of metal; the cover plate shall have a minimum thickness of 6 mm ( $\frac{1}{4}$  in). Grooves may be incorporated into the surface of the cover plate contacting the surface of the cement. Glass plates are not recommended for tests above 110 °C (230 °F) because of the risk of silica replacement.

**7.4.3 Water curing bath** or tank, having dimensions permitting the complete immersion of moulds for compressive-strength test samples in water, and capable of maintaining the specified test temperatures within  $\pm 2$  °C ( $\pm 3$  °F).

The two types of water curing baths are:

a) **atmospheric-pressure curing bath** (unpressurized), having an agitator or circulating system.

Atmospheric-pressure curing baths at or below 66 °C (150 °F) may be used for curing samples for compressive-strength testing when higher pressure is not required.

b) **pressurized curing bath**, suitable for curing samples at the appropriate final test temperature and recommended as capable of maintaining a pressure of at least 20 700 kPa (3 000 psi).

The vessel shall be capable of being heated at the desired rate.

**7.4.4 Cooling bath**, designed so that the specimen to be cooled from the curing temperature can be completely submerged in water maintained at 27 °C  $\pm$  3 °C (80 °F  $\pm$  5 °F).

**7.4.5 Temperature-measuring system**, calibrated to an accuracy of  $\pm 2$  °C ( $\pm 3$  °F) no less frequently than monthly.

The calibration procedure described in Annex B is commonly used. Three commonly used temperature-measuring systems are as follows:

a) A thermometer, of range  $-18$  °C to 104 °C (0 °F to 220 °F), with minimum scale divisions not to exceed 1 °C (2 °F) may be used in a non-pressurized vessel.

b) A thermocouple, of range  $-18$  °C to 104 °C (0 °F to 220 °F), calibrated to an accuracy of  $\pm 2$  °C ( $\pm 3$  °F) is preferred in a non-pressurized vessel.

c) A thermocouple, of range  $-18$  °C to at least 204 °C (0 °F to at least 400 °F), calibrated to an accuracy of  $\pm 2$  °C (3 °F), shall be used in pressurized vessels.

**7.4.6 Puddling rod**, corrosion-resistant, typically with a width of 6 mm  $\pm$  0,5 mm ( $\frac{1}{4}$  in).

**7.4.7 Mould-sealing grease**, possessing the following properties when subjected to anticipated test temperatures and pressures is suitable for use:

- a) a consistency to permit ease of application;
- b) good sealing properties to prevent leakage;
- c) water resistance;
- d) inert to the cement.
- e) non-corrosive in the temperature range  $-18\text{ °C}$  to at least  $204\text{ °C}$  ( $0\text{ °F}$  to at least  $400\text{ °F}$ ).

**7.4.8 Mould-release agent** (optional).

A thin layer of mould-release agent may be applied to the interior surfaces of the mould to prevent the sample from being damaged when removed from the mould.

## **7.5 Procedure**

### **7.5.1 Preparation of moulds**

The interior faces of the moulds and the contact surfaces of the plates are commonly coated with mould release agent, but may be clean and dry. The assembled moulds shall be water tight. Care shall be taken to ensure there is no bead of sealant on the interior of the mould (Figure 6).

### **7.5.2 Preparation and placement of cement slurry**

#### **7.5.2.1 Preparation**

Prepare the cement slurry in accordance with Clause 5.

#### **7.5.2.2 Placement**

Pour the cement slurry into the prepared moulds to approximately one-half of the mould depth. Puddle each sample approximately 30 times with a puddling rod after all mould chambers have received slurry. Stir the remaining slurry by hand to re-suspend the components. Fill each sample mould to overflowing with slurry and puddle the same as the first layer. After puddling, strike off the excess slurry even with the top of the mould using a straight edge. Discard specimens in moulds that leak. Place the cover plate on top of the moulds. For each test, use at least three specimens.

### **7.5.3 Curing at atmospheric pressure**

After the moulds have been filled and covered with the cover plate, immediately place them in a water curing bath maintained at the desired curing temperature. Raise the moulds off the bottom of the bath using a perforated baffle plate or suitable spacers to allow water to completely circulate around the samples during the curing period. At approximately 45 min prior to the age at which the samples are to be tested, remove the moulds from the water bath and remove the cured samples from the moulds. Immediately immerse the samples in a water cooling bath at  $27\text{ °C} \pm 3\text{ °C}$  ( $80\text{ °F} \pm 5\text{ °F}$ ) until the samples are tested.

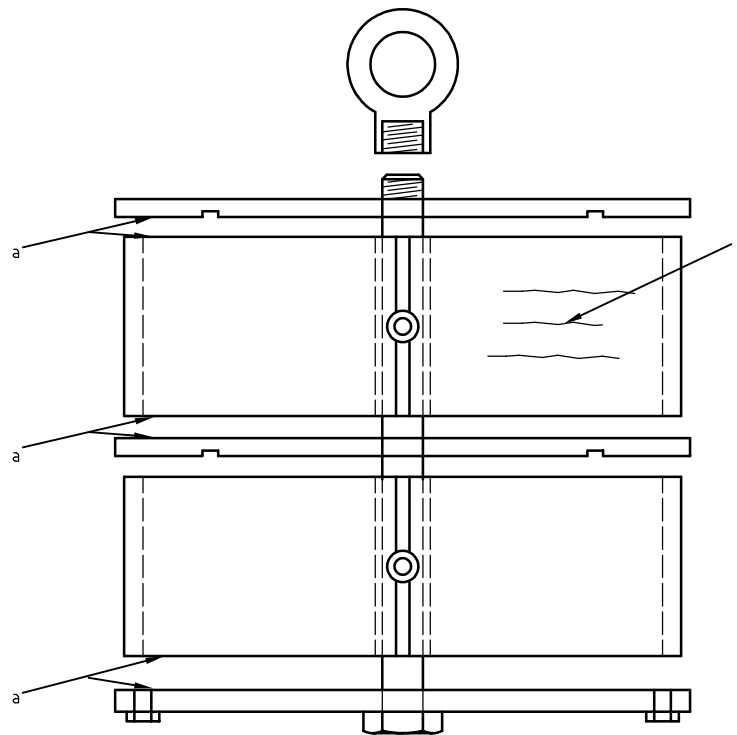
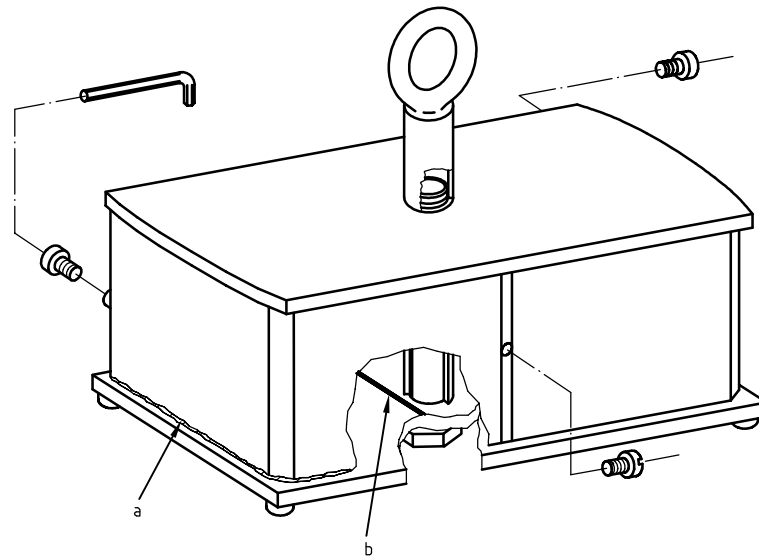

- a Grease lightly here.
- b Remove extruded grease.
- c Apply mould release agent inside sample cavity.

Figure 6 — Diagram of mould preparation

#### 7.5.4 Curing at pressures above atmospheric

After the moulds have been filled and covered with the top plate, immediately place them in a pressurized curing vessel at the desired test initiation temperature [normally  $27\text{ °C} \pm 3\text{ °C}$  ( $80\text{ °F} \pm 5\text{ °F}$ )]. Apply heat and pressure in accordance with the test schedule. Cement samples may be cured in accordance with pressure/temperature schedules provided in Table 2 (see below) or to a schedule designed to simulate conditions in a specific well.

For samples cured at or below  $90\text{ °C}$  ( $194\text{ °F}$ ), maintain test temperature and pressure until 45 min prior to testing. For test temperatures above  $90\text{ °C}$  ( $194\text{ °F}$ ), discontinue heating and allow samples to cool at such a rate that the sample temperature is  $90\text{ °C}$  ( $194\text{ °F}$ ) or less 45 min prior to testing. Maintain test pressure on the curing vessel during the cooling process. At 45 min prior to testing the samples, release the pressure gradually and remove the moulds from the curing vessel. Immediately remove the samples from the moulds and place them in a water bath maintained at  $27\text{ °C} \pm 3\text{ °C}$  ( $80\text{ °F} \pm 5\text{ °F}$ ) until the samples are tested.

#### 7.5.5 Test period

The test period is the time elapsed from subjecting the sample to heat in the curing vessel to testing the sample for strength.

#### 7.5.6 Sample testing

Test samples immediately after removal from the cooling bath. The test procedure shall be in accordance with ASTM C 109, except for the following aspects.

- a) A compressive strength testing device shall be used, and the rate of loading for samples with strength greater than  $3,5\text{ MPa}$  ( $500\text{ psi}$ ) shall be  $71,7\text{ kN} \pm 7,2\text{ kN}$  ( $16\ 000\text{ lbf} \pm 1\ 600\text{ lbf}$ ,  $4\ 000\text{ psi} \pm 400\text{ psi}$ ) per minute. For a nominal  $2\ 580,64\text{ mm}^2$  ( $4\text{ in}^2$ ) sample surface, this rate can be achieved by adjusting the load rate to obtain a gauge indicator travel from  $8,9\text{ kN}$  to  $26,8\text{ kN}$  ( $2\ 000\text{ lbf}$  and  $6\ 000\text{ lbf}$ ) gauge reading in 15 s. For samples with strength of  $3,5\text{ MPa}$  ( $500\text{ psi}$ ) or less, a loading rate of  $17,9\text{ kN} \pm 1,8\text{ kN}$  ( $1\ 000\text{ psi} \pm 100\text{ psi}$ ,  $4\ 000\text{ lbf} \pm 400\text{ lbf}$ ) per minute shall be used. For a nominal  $4\text{ in}^2$  sample surface, this rate can be achieved by adjusting the load rate to obtain a gauge indicator travel from  $8,9\text{ kN}$  to  $26,8\text{ kN}$  ( $2\ 000\text{ lbf}$  and  $6\ 000\text{ lbf}$ ) gauge reading in 1 min. Make no adjustment in the controls of the testing machine while a sample is yielding before failure.
- b) Report compressive strength as the force required to break the sample divided by the smallest measured cross-sectional area in contact with the load-bearing plates of the compression tester. Average the compressive strength of all acceptable test samples (see ASTM C 109) made from the same slurry and tested at the same time. Report compressive strength results to the nearest  $0,1\text{ MPa}$  ( $10\text{ psi}$ ) and include the test schedule used.

### 7.6 Determination of cement compressive strength at the top of long cement columns

#### 7.6.1 Guidelines for use

Use this procedure if the bottom-hole circulating temperature ( $T_{\text{BHC}}$ ) is higher than the static temperature at the top of the cement column ( $T_{\text{TOCS}}$ ).

#### 7.6.2 Procedure

**7.6.2.1** Prepare a cement slurry in accordance with Clause 5. Pour the slurry into the slurry container of a pressurized consistometer, and heat to  $T_{\text{BHC}}$  in accordance with the pressure/temperature schedules provided in Annex E or a schedule designed to simulate conditions in a specific well. Hold test temperature and pressure for 60 min to allow the cement temperature to reach equilibrium.

**7.6.2.2** Upon completion of the appropriate test schedule, plus the 60 min to reach equilibrium, cool to the top-of-cement circulating temperature ( $T_{\text{TOCC}}$ ) or  $90\text{ °C}$  ( $194\text{ °F}$ ), whichever is lower, at a rate of  $1,0\text{ °C/min}$  ( $2,0\text{ °F/min}$ ). Use the following equation to determine the cool-down time ( $t$ ), in minutes.



**For SI units:**

$$t = \frac{T_{\text{BHC}} - T_{\text{TOCC}}}{1,0 \text{ } ^\circ\text{C}} \quad (1)$$

**For US customary units:**

$$t = \frac{T_{\text{BHC}} - T_{\text{TOCC}}}{2,0 \text{ } ^\circ\text{F}} \quad (2)$$

where:

$t$  is the cool-down time, expressed in minutes;

$T_{\text{BHC}}$  is the bottom-hole circulating temperature, expressed in  $^\circ\text{C}$  or  $^\circ\text{F}$

$T_{\text{TOCC}}$  is the top-of-cement circulating temperature, expressed in  $^\circ\text{C}$  or  $^\circ\text{F}$ .

Decrease the temperature while maintaining test pressure. When the  $T_{\text{TOCC}}$  or  $90 \text{ } ^\circ\text{C}$  ( $190 \text{ } ^\circ\text{F}$ ) (whichever is lower) is reached, release the pressure slowly and remove the slurry container.

**7.6.2.3** Take care to minimize oil contamination of the slurry. Open the slurry container from the top (while leaving the paddle in place). This eliminates the need for inverting the slurry container and reduces contamination that could be caused by oil migrating through the slurry. Blot the top of the slurry with an absorbent cloth or paper towel to remove any visible oil. Transfer the slurry three (3) times between the slurry container and a beaker, to re-suspend any solids that may have settled.

**7.6.2.4** Pour the slurry into prepared moulds as specified in 7.5.2.2, and place the moulds in a preheated curing vessel [preheated to  $T_{\text{TOCC}}$  or  $90 \text{ } ^\circ\text{C}$  ( $194 \text{ } ^\circ\text{F}$ ), whichever is lower]. A non-destructive sonic test device as described in Clause 8 may also be used. No longer than 15 min after removing the slurry from the consistometer, apply  $20\,700 \text{ kPa} \pm 3\,400 \text{ kPa}$  ( $3\,000 \text{ psi} \pm 500 \text{ psi}$ ) curing pressure.

**7.6.2.5** Adjust sample temperature  $T_{\text{TOCS}}$  to the final curing temperature over a time period appropriate to well conditions, while maintaining curing pressure. If a time to reach final conditions is not known or specified, use 6 h.

**7.6.2.5** Remove samples as specified in 7.5.4.

**7.6.2.6** Test the samples for strength in accordance with procedures in 7.5.6 or Clause 8.

Table 2 — Well-simulation test schedules for curing compressive strength specimens

1	2	3	4	5	6	7	8	9						
Schedule <sup>a</sup>	Elapsed time <sup>b</sup> min	Pressure <sup>c</sup> kPa (psi)	Temperature gradient, °C/100 m depth (°F/100 ft depth) <sup>d</sup>											
			°C (°F)	°C (°F)	°C (°F)	°C (°F)	°C (°F)	°C (°F)	°C (°F)	°C (°F)	°C (°F)	°C (°F)		
	Temperature, °C (°F)													
1 Sg 305 m (1 000 ft)	15	5 500 (800)	27 (80)	27 (80)	27 (80)	27 (80)	27 (80)	27 (80)	27 (80)	27 (80)	27 (80)	27 (80)	27 (80)	
	30		27 (81)	27 (81)	27 (81)	27 (81)	27 (81)	27 (81)	27 (81)	27 (81)	27 (81)	27 (81)	27 (81)	
	60		28 (82)	28 (82)	28 (83)	28 (83)	28 (83)	29 (84)	29 (84)	29 (84)	29 (84)	29 (84)	29 (84)	
	90		28 (83)	29 (84)	29 (84)	29 (84)	29 (85)	30 (86)	30 (86)	30 (86)	30 (86)	30 (86)	30 (86)	
	120		29 (84)	29 (85)	30 (86)	31 (87)	31 (87)	31 (88)	31 (88)	31 (88)	31 (88)	31 (88)	31 (88)	
	150		29 (85)	31 (87)	31 (88)	32 (89)	32 (89)	32 (90)	32 (90)	32 (90)	32 (90)	32 (90)		
	180		31 (87)	31 (88)	32 (90)	33 (91)	33 (91)	34 (93)	34 (93)	34 (93)	34 (93)	34 (93)		
	210		31 (88)	32 (90)	33 (91)	34 (93)	34 (93)	35 (95)	35 (95)	35 (95)	35 (95)	35 (95)		
	240		32 (89)	33 (91)	34 (93)	35 (95)	35 (95)	36 (97)	36 (97)	36 (97)	36 (97)	36 (97)		
2 Sg 610 m (2 000 ft)	15	11 000 (1 600)	31 (88)	31 (88)	32 (89)	32 (89)	32 (89)	32 (90)	32 (90)	32 (90)	32 (90)	32 (90)		
	30		32 (90)	32 (90)	33 (91)	33 (91)	33 (91)	33 (92)	33 (92)	33 (92)	33 (92)	33 (92)		
	60		33 (91)	33 (92)	34 (93)	34 (94)	34 (94)	35 (95)	35 (95)	35 (95)	35 (95)	35 (95)		
	90		33 (92)	34 (93)	35 (95)	36 (97)	36 (97)	37 (99)	37 (99)	37 (99)	37 (99)	37 (99)		
	120		34 (93)	35 (95)	36 (97)	37 (99)	37 (99)	39 (102)	39 (102)	39 (102)	39 (102)	39 (102)		
	150		34 (94)	36 (97)	38 (100)	39 (102)	39 (102)	41 (105)	41 (105)	41 (105)	41 (105)			
	180		36 (96)	37 (99)	39 (102)	41 (105)	41 (105)	42 (108)	42 (108)	42 (108)	42 (108)			
	210		36 (97)	38 (100)	40 (104)	42 (107)	42 (107)	44 (111)	44 (111)	44 (111)	44 (111)			
	240		37 (98)	39 (102)	41 (106)	43 (110)	43 (110)	46 (114)	46 (114)	46 (114)	46 (114)			
3 Sg 1 220 m (4 000 ft)	15	20 700 (3 000)	33 (91)	33 (92)	34 (93)	34 (93)	34 (93)	34 (94)	34 (94)	34 (94)	34 (94)	34 (94)		
	30		37 (99)	38 (101)	39 (102)	39 (103)	39 (103)	40 (104)	40 (104)	40 (104)	40 (104)	40 (104)		
	60		39 (102)	40 (104)	41 (106)	42 (108)	42 (108)	43 (110)	43 (110)	43 (110)	43 (110)	43 (110)		
	90		40 (104)	42 (107)	43 (110)	45 (113)	45 (113)	47 (117)	47 (117)	47 (117)	47 (117)	47 (117)		
	120		42 (107)	44 (111)	46 (115)	48 (119)	48 (119)	51 (123)	51 (123)	51 (123)	51 (123)	51 (123)		
	150		43 (109)	46 (114)	48 (119)	51 (124)	51 (124)	54 (129)	54 (129)	54 (129)	54 (129)			
	180		44 (111)	47 (117)	51 (123)	54 (129)	54 (129)	57 (135)	57 (135)	57 (135)	57 (135)			
	210		46 (114)	49 (121)	53 (128)	57 (135)	57 (135)	61 (142)	61 (142)	61 (142)	61 (142)			
	240		47 (116)	51 (124)	56 (132)	60 (140)	60 (140)	64 (148)	64 (148)	64 (148)	64 (148)			
4 Sg 1 830 m (6 000 ft)	15	20 700 (3 000)	35 (95)	35 (95)	36 (96)	36 (97)	36 (97)	37 (98)	37 (98)	37 (98)	37 (98)	37 (98)		
	30		43 (109)	44 (111)	45 (113)	46 (115)	46 (115)	47 (116)	47 (116)	47 (116)	47 (116)	47 (116)		
	45		45 (113)	47 (116)	48 (118)	49 (121)	49 (121)	51 (124)	51 (124)	51 (124)	51 (124)	51 (124)		
	60		46 (115)	48 (118)	49 (121)	52 (125)	52 (125)	53 (128)	53 (128)	53 (128)	53 (128)	53 (128)		
	90		48 (118)	51 (123)	53 (128)	56 (132)	56 (132)	58 (137)	58 (137)	58 (137)	58 (137)	58 (137)		
	120		49 (121)	53 (127)	57 (134)	60 (140)	60 (140)	63 (146)	63 (146)	63 (146)	63 (146)			
	150		51 (124)	56 (132)	60 (140)	64 (147)	64 (147)	68 (155)	68 (155)	68 (155)	68 (155)			
	180		53 (128)	58 (137)	63 (146)	68 (155)	68 (155)	73 (164)	73 (164)	73 (164)	73 (164)			
	210		55 (131)	61 (141)	67 (152)	72 (162)	72 (162)	78 (173)	78 (173)	78 (173)	78 (173)			
240		57 (134)	63 (146)	70 (158)	77 (170)	77 (170)	83 (182)	83 (182)	83 (182)	83 (182)				

Table 2 — (continued)

1	2	3	4	5	6	7	8	9						
Schedule <sup>a</sup>	Elapsed time <sup>b</sup> min	Pressure <sup>c</sup> kPa (psi)	Temperature gradient, °C/100 m depth (°F/100 ft depth) <sup>d</sup>											
			°C (°F)	°C (°F)	°C (°F)	°C (°F)	°C (°F)	°C (°F)	°C (°F)	°C (°F)				
	Temperature, °C (°F)													
5 Sg 2 440 m (8 000 ft)	15	20 700 (3 000)	36 (97)	37 (98)	38 (100)	39 (102)	40 (104)	43 (109)						
	30		46 (114)	47 (116)	49 (120)	51 (124)	53 (128)	59 (139)						
	45		53 (127)	54 (130)	58 (136)	61 (141)	64 (147)	72 (161)						
	60		53 (128)	56 (133)	60 (140)	63 (146)	67 (153)	75 (167)						
	90		56 (132)	59 (139)	64 (147)	68 (155)	73 (163)	81 (178)						
	120		58 (136)	62 (144)	68 (154)	73 (164)	79 (174)	87 (189)						
	150		60 (140)	66 (150)	72 (162)	78 (173)	84 (184)	93 (199)						
	180		62 (144)	69 (156)	76 (169)	83 (182)	91 (195)	99 (210)						
	210		64 (148)	72 (162)	81 (177)	88 (191)	96 (205)	105 (221)						
	240		67 (152)	76 (168)	84 (184)	93 (200)	102 (216)	111 (232)						
6 Sg 3 050 m (10 000 ft)	15	20 700 (3 000)	37 (98)	38 (100)	39 (103)	41 (106)	43 (110)	47 (116)						
	30		47 (116)	49 (120)	53 (127)	56 (132)	60 (140)	67 (152)						
	45		57 (134)	59 (139)	66 (150)	70 (158)	77 (170)	87 (188)						
	60		61 (142)	64 (148)	72 (161)	77 (170)	84 (184)	96 (204)						
	90		63 (146)	68 (155)	76 (169)	82 (180)	91 (195)	102 (215)						
	120		66 (151)	72 (162)	81 (177)	88 (190)	97 (206)	108 (226)						
	150		69 (156)	76 (169)	85 (185)	93 (200)	103 (217)	114 (237)						
	180		72 (161)	80 (176)	90 (194)	99 (210)	109 (228)	120 (248)						
	210		74 (165)	84 (183)	94 (202)	104 (220)	115 (239)	126 (259)						
	240		77 (170)	88 (190)	99 (210)	110 (230)	121 (250)	132 (270)						
7 Sg 3 660 m (12 000 ft)	15	20 700 (3 000)	37 (98)	39 (102)	42 (107)	44 (111)	47 (116)	49 (120)						
	30		46 (115)	51 (124)	56 (133)	62 (143)	67 (152)	72 (161)						
	45		56 (133)	63 (146)	71 (160)	79 (174)	87 (188)	94 (201)						
	60		64 (148)	74 (166)	84 (184)	94 (202)	104 (220)	114 (237)						
	90		68 (155)	78 (173)	89 (192)	99 (211)	110 (230)	121 (249)						
	120		72 (162)	83 (181)	94 (201)	105 (221)	116 (241)	127 (261)						
	150		76 (168)	87 (189)	99 (210)	111 (231)	122 (252)	133 (272)						
	180		79 (175)	92 (197)	104 (219)	116 (241)	128 (263)	140 (284)						
	210		83 (181)	96 (204)	108 (227)	121 (250)	134 (273)	147 (296)						
	240		87 (188)	100 (212)	113 (236)	127 (260)	140 (284)	153 (308)						

Table 2 — (continued)

1	2	3	4	5	6	7	8	9						
Schedule <sup>a</sup>	Elapsed time <sup>b</sup> min	Pressure <sup>c</sup> kPa (psi)	Temperature gradient, °C/100 m depth (°F/100 ft depth) <sup>d</sup>											
			°C (°F)	°C (°F)	°C (°F)	°C (°F)	°C (°F)	°C (°F)	°C (°F)	°C (°F)				
	Temperature, °C (°F)													
8 Sg 4 270 m (14 000 ft)	15	20 700 (3 000)	37 (99)	40 (104)	43 (109)	46 (114)	48 (119)	51 (123)						
	30		48 (118)	53 (128)	59 (138)	64 (147)	69 (157)	75 (167)						
	45		58 (137)	67 (152)	75 (167)	83 (181)	91 (196)	99 (210)						
	60		69 (156)	79 (175)	91 (195)	102 (215)	113 (235)	123 (254)						
	75		74 (166)	87 (188)	99 (210)	111 (231)	123 (254)	135 (275)						
	90		77 (170)	89 (192)	102 (215)	114 (237)	126 (259)	138 (281)						
	120		81 (177)	93 (200)	107 (224)	119 (247)	133 (271)	146 (294)						
	150		84 (184)	98 (209)	112 (234)	126 (258)	139 (283)	153 (307)						
	180		89 (192)	103 (217)	117 (243)	132 (269)	146 (295)	160 (320)						
	210		93 (199)	108 (226)	123 (253)	137 (279)	152 (306)	167 (333)						
	240		97 (206)	112 (234)	128 (262)	143 (290)	159 (318)	174 (346)						
9 Sg 4 880 m (16 000 ft)	15	20 700 (3 000)	38 (101)	41 (106)	44 (111)	47 (116)	49 (121)	52 (126)						
	30		49 (121)	55 (131)	61 (142)	67 (152)	73 (163)	78 (173)						
	45		61 (142)	69 (157)	78 (173)	87 (188)	96 (204)	104 (219)						
	60		73 (163)	84 (183)	96 (204)	107 (224)	118 (245)	130 (266)						
	75		83 (182)	97 (207)	112 (233)	126 (258)	140 (284)	154 (309)						
	90		86 (186)	100 (212)	114 (238)	129 (264)	144 (291)	158 (316)						
	120		90 (194)	105 (221)	120 (248)	135 (275)	151 (303)	166 (330)						
	150		94 (201)	109 (229)	126 (258)	141 (286)	157 (315)	173 (343)						
	180		98 (209)	114 (238)	131 (268)	148 (298)	164 (327)	181 (357)						
	210		102 (216)	119 (247)	137 (278)	154 (309)	171 (340)	188 (370)						
	240		107 (224)	124 (256)	142 (288)	160 (320)	178 (352)	196 (384)						
10 Sg 5 490 m (18 000 ft)	15	20 700 (3 000)	39 (102)	42 (108)	45 (113)	48 (119)	51 (124)	54 (129)						
	30		51 (124)	57 (135)	63 (146)	69 (157)	76 (168)	82 (179)						
	45		63 (146)	73 (163)	82 (179)	91 (196)	100 (212)	109 (228)						
	60		76 (169)	88 (190)	100 (212)	112 (234)	124 (256)	137 (278)						
	75		88 (191)	103 (218)	119 (246)	134 (273)	149 (300)	164 (327)						
	90		95 (203)	112 (233)	129 (264)	146 (294)	162 (324)	179 (354)						
	120		99 (211)	117 (242)	134 (274)	152 (305)	169 (337)	186 (367)						
	150		104 (219)	122 (251)	140 (284)	158 (316)	176 (349)	194 (381)						
	180		108 (226)	127 (260)	146 (294)	164 (328)	183 (361)	202 (395)						
	210		112 (234)	132 (269)	151 (304)	171 (339)	190 (374)	209 (408)						
	240		117 (242)	137 (278)	157 (314)	177 (350)	197 (386)	217 (422)						

Table 2 — (continued)

1	2	3		4		5		6		7		8		9	
Schedule <sup>a</sup>	Elapsed time <sup>b</sup> min	Pressure <sup>c</sup> kPa (psi)		Temperature gradient, °C/100 m depth (°F/100 ft depth) <sup>d</sup>											
				°C	(°F)	°C	(°F)	°C	(°F)	°C	(°F)	°C	(°F)	°C	(°F)
	Temperature, °C (°F)														
11 Sg 6 100 m (20 000 ft)	15	20 700	(3 000)	40	104	43	(109)	46	(115)	49	(121)	53	(127)	56	(133)
	30			53	127	59	(139)	66	(150)	72	(162)	78	(173)	85	(185)
	45			66	151	76	(168)	86	(186)	95	(203)	104	(220)	114	(238)
	60			79	175	92	(197)	105	(221)	118	(244)	131	(267)	143	(290)
	75			92	198	108	(227)	124	(256)	141	(285)	156	(313)	173	(343)
	90			106	222	124	(256)	144	(291)	163	(326)	182	(360)	202	(395)
	120			110	230	129	(265)	149	(301)	169	(337)	189	(372)	209	(408)
	150			114	237	134	(274)	155	(311)	176	(348)	196	(384)	216	(421)
	180			118	245	139	(282)	160	(320)	181	(358)	202	(396)	223	(434)
	210			122	252	144	(291)	166	(330)	187	(369)	209	(408)	231	(447)
240			127	260	149	(300)	171	(340)	193	(380)	216	(420)	238	(460)	
AC <sub>1</sub> 12 Sg 6 710 m (22 000 ft) AC <sub>1</sub>	15	20 700	(3 000)	41	(105)	44	(111)	47	(117)	51	(123)	54	(130)	58	(136)
	30			54	(130)	61	(142)	68	(155)	75	(167)	82	(179)	88	(191)
	45			68	(155)	79	(174)	89	(192)	99	(210)	109	(229)	119	(247)
	60			82	(180)	96	(205)	109	(229)	123	(254)	137	(278)	151	(303)
	75			97	(206)	113	(236)	131	(267)	147	(297)	164	(328)	182	(359)
	90			111	(231)	131	(267)	151	(304)	172	(341)	192	(378)	212	(414)
	105			119	(246)	141	(286)	163	(326)	186	(366)	208	(406)	231	(447)
	120			121	(249)	143	(290)	166	(331)	188	(371)	211	(412)	233	(452)
	150			124	(256)	148	(298)	171	(339)	194	(381)	217	(422)	240	(464)
	180			129	(264)	152	(306)	176	(348)	199	(391)	223	(433)	246	(475)
210			133	(271)	157	(314)	181	(357)	204	(400)	228	(443)	253	(487)	
240			137	(278)	161	(322)	186	(366)	210	(410)	234	(454)	259	(498)	

<sup>a</sup> Sg is a schedule number designation.

<sup>b</sup> The temperature shall be increased in equal amounts at 15 min intervals until the 4 h (240 min) temperature is reached.  
The 4 h temperature shall be maintained until completion of test.

Final temperature shall be maintained within  $\pm 2$  °C ( $\pm 3$  °F) throughout the remainder of the curing period.

<sup>c</sup> The test pressure shall be applied as soon as specimens are placed in the pressure vessel and maintained at the given pressure within the following limits for the duration of the curing period:

Schedule 1 Sg 5 500 kPa  $\pm$  700 kPa (800 psi  $\pm$  100 psi).

Schedule 2 Sg 11 000 kPa  $\pm$  1 400 kPa (1 600 psi  $\pm$  200 psi).

Schedule 3 Sg-11 Sg 20 700 kPa  $\pm$  3 400 kPa (3 000 psi  $\pm$  500 psi).

<sup>d</sup> Temperature gradient =  $(T_{\text{BHS}} - 27$  °C) / 100 m depth or  $(T_{\text{BHS}} - 80$  °F) / 100 ft depth

$T_{\text{BHS}}$  = Bottom-Hole Static Temperature

## 8 Non-destructive sonic testing of cement

### 8.1 General

This clause presents testing procedures for the non-destructive sonic testing of cement. The apparatus transmits a sonic signal through the cement being tested. The signal transit time can be correlated to cement properties such as the time and extent of strength development.

Non-destructive sonic testing of cement is not required for compliance with ISO 10426-1.

### 8.2 Apparatus

**8.2.1 Curing cell**, which can be subjected to controlled temperature and pressure for curing the cement slurry.

The cell shall include the following systems:

a) **Temperature-measuring system**, calibrated to an accuracy of  $\pm 2$  °C ( $\pm 3$  °F).

Calibration shall be no less frequent than monthly and may be performed in accordance with the procedure described in Annex B.

b) **Sonic signal measuring system**, calibrated in accordance with the manufacturer's instructions.

### 8.3 Sampling

Samples of the cement, additives, and mix water shall be obtained in accordance with Clause 4.

### 8.4 Preparation of slurry

The slurry shall be prepared in accordance with Clause 5.

Excessive free fluid can impair the accuracy of this test. Free fluid in a slurry can cause cement to lose contact with the top cell cover plate and affect the signal being sent through the cement. The percentage of free fluid can be determined in accordance with 15.4 and 15.5.

### 8.5 Procedure

Follow the detailed operating instructions and safety precautions furnished by the manufacturer.

### 8.6 Curing time

The curing period begins with the recording of the transit time and the application of temperature and pressure, and continues until the test is terminated. Recording of transit-time data shall begin within 5 min after application of temperature and pressure.

### 8.7 Curing schedules

Cement samples may be cured in accordance with pressure/temperature schedules provided in Clause 7 or with a schedule designed to simulate specific well conditions.

NOTE Planned or unplanned changes in temperature or pressure alter the transit time.

## 8.8 Data reporting

**8.8.1** The transit time shall be continuously monitored. The strength of the cement sample shall be obtained from transit time correlations.

**8.8.2** After removal of the sample from the curing cell, it is occasionally surfaced (cut into cube) and crushed. The result obtained is not comparable to that found using the method described in Clause 7. The result shall not be reported as ISO compressive strength.

## 9 Well-simulation thickening-time tests

### 9.1 General

Recommended procedures for determining the well-simulation thickening time of a cement slurry are provided in this clause. The results of the laboratory thickening-time test provide an indication of the length of time that a cement slurry will remain pumpable in a well. The laboratory test conditions shall represent the time, temperature and pressure to which a cement slurry will be exposed during pumping operations.

Well-simulation thickening-time tests are not required for compliance with ISO 10426-1.

### 9.2 Apparatus and material

#### 9.2.1 Pressurized consistometer, see Figure 7.

The most commonly used apparatus incorporates a rotating cylindrical slurry container equipped with a stationary paddle assembly, all enclosed in a pressure vessel capable of withstanding well-simulation pressures and temperatures. The slurry container is rotated at a speed of 150 r/min  $\pm$  15 r/min. An alternative apparatus is described in Annex D.

The paddle and all parts of the slurry container exposed to the slurry shall be constructed of corrosion-resistant materials. The space between the slurry container and the walls of the pressure vessel shall be completely filled with hydrocarbon oil (9.2.2).

The temperature and consistency of the cement slurry (9.3.2) shall be measured. See Annex B for temperature-measuring systems.

**NOTE** The alternative apparatus used to conduct well-simulation thickening-time tests described in Annex D utilizes a rotating paddle and stationary slurry container. Generalized operating procedures for the alternative apparatus are also found in Annex D.

#### 9.2.2 Hydrocarbon oil, selected to have the following physical properties:

Viscosity = 7 mm/s<sup>2</sup> to 75 mm/s<sup>2</sup> at 38 °C (7 cSt to 75 cSt at 100 °F)

Specific heat = 2,1 kJ/(kg·K) to 2,4 kJ/(kg·K) (0,5 Btu/lb·°F to 0,58 Btu/lb·°F)

Thermal conductivity = 0,119 W/(m·K) to 0,133 W/(m·K) (0,068 5 Btu/h·ft<sup>2</sup>·°F/ft to 0,077 0 Btu/h·ft<sup>2</sup>·°F/ft)

Relative density = 0,85 to 0,91

A synthetic oil with suitable properties shall be used only if the test temperature exceeds the flash point of the hydrocarbon oil.

#### 9.2.3 Heating system, capable of raising the temperature of the oil bath at a rate of at least 3 °C (5 °F) per minute.

Temperature-measuring systems shall be provided for determining the temperature of the oil bath and also that of the cement slurry (see Annex B).

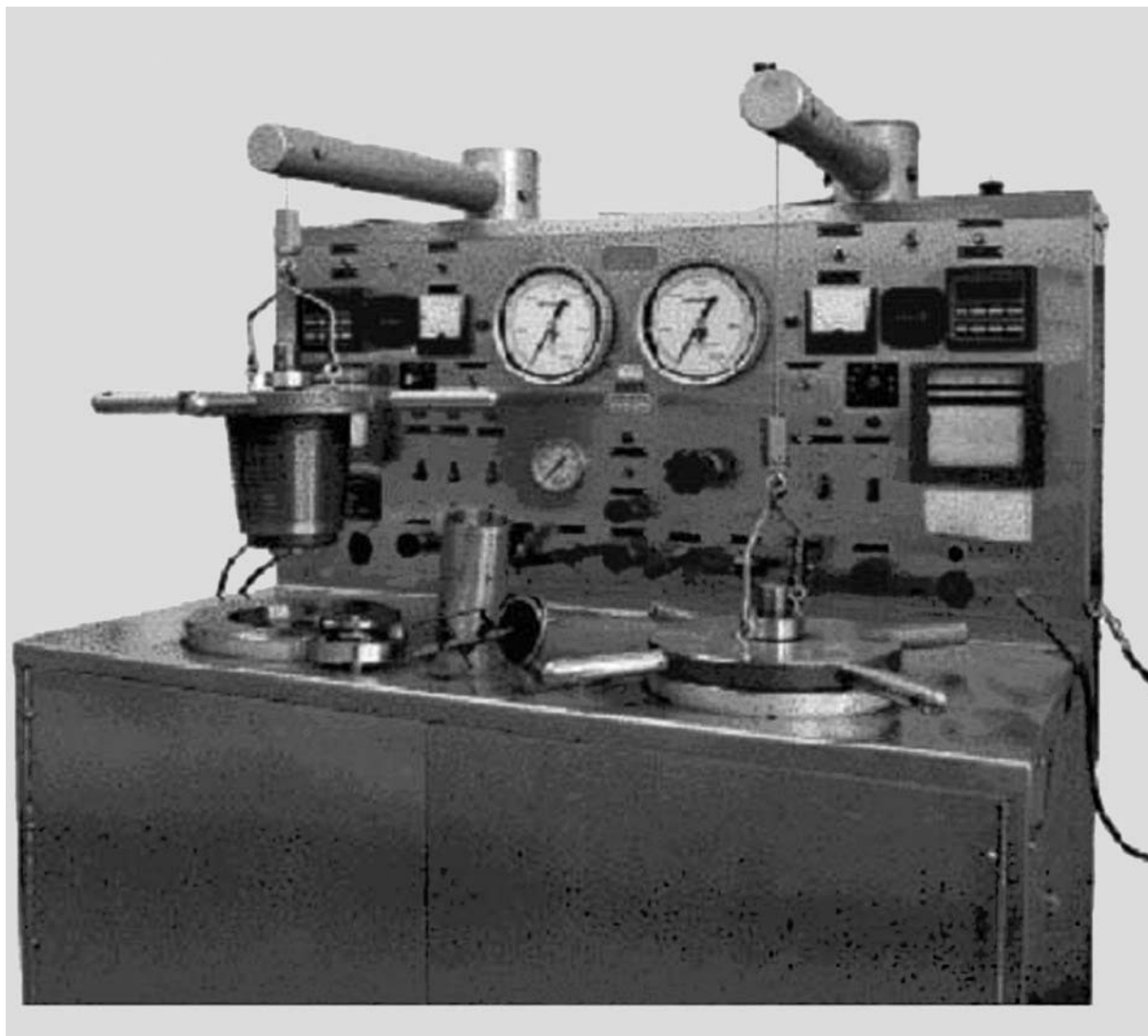

Figure 7 — Typical pressurized consistometer

### 9.3 Calibration

#### 9.3.1 General

Measurement of the thickening time of a cement slurry requires calibration and maintenance of operating systems of the pressurized consistometer, including consistency measurement, temperature-measuring systems, temperature controllers, motor speed, timer and pressure gauges.

#### 9.3.2 Consistency

Consistency of a cement slurry is expressed in Bearden units ( $B_c$ ). This value is determined by a potentiometer mechanism and voltage-measurement circuit. These shall be calibrated monthly and whenever the calibration spring, resistor or contact arm is adjusted or replaced. The following calibration method shall be used.



A weight-loaded device (Figure 8), for typical potentiometer calibration, is used to produce a series of torque-equivalent values for consistency, defined by the following equation:

$$T = 78,2 + 20,02 B_C \quad (3)$$

where:

$T$  is the torque, expressed in gram-centimetres (g-cm);

$B_C$  consistency expressed in Bearden units.

Weights are used to apply torque to the potentiometer spring, using the radius of the potentiometer frame as a lever arm. As weights are added, the contact arm is deflected and the resulting DC voltage is recorded and used to determine  $B_C$  (see manufacturer's instruction manual for procedures). An example is given in Table 3. Some devices display  $B_C$  directly.

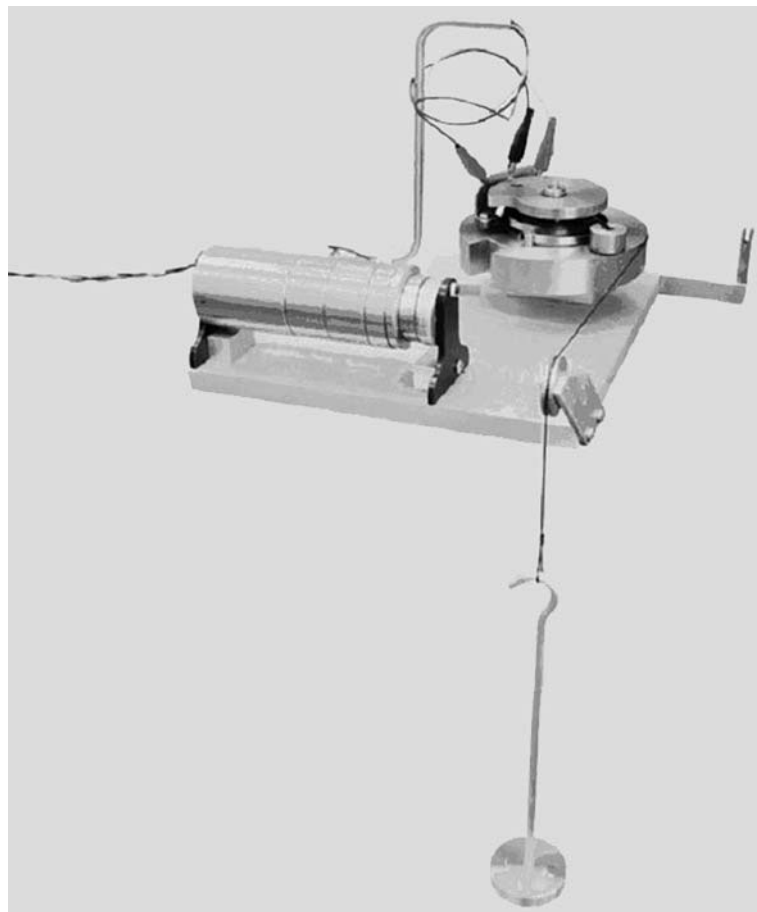

Figure 8 — Typical calibrating device for pressurized consistometer

**Table 3 — Slurry consistency vs. equivalent torque**  
(for a potentiometer mechanism with a radius of 52 mm ± 1 mm)<sup>a</sup>

Calculated torque equivalent g·cm	Mass of added weights g ± 0,1	Calculated slurry consistency $B_c$
260	50	9
520	100	22
780	150	35
1 040	200	48
1 300	250	61
1 560	300	74
1 820	350	87
2 080	400	100

<sup>a</sup> For a potentiometer mechanism with a radius other than 52 mm ± 1 mm, an appropriate table with equivalent tolerances shall be developed.

### 9.3.3 Temperature-measuring system

The temperature-measuring device system shall be calibrated to an accuracy of ± 2 °C (± 3 °F). Calibration shall be no less frequent than monthly and may be performed in accordance with the procedure described in Annex B.

### 9.3.4 Motor speed

Rotational speed of the slurry container shall be 150 r/min ± 15 r/min (2,5 rev/s ± 0,25 rev/s) and shall be checked no less frequently than every three months.

### 9.3.5 Timer

Timers shall be accurate within ± 30 s per h and shall be checked for accuracy every six months.

### 9.3.6 Pressure-measuring devices

Calibration shall be conducted annually against a deadweight tester or master gauge to 0,25 % of full range at a minimum of 25 %, 50 % and 75 % of full scale.

## 9.4 Test procedure

### 9.4.1 Operating instructions

**WARNING** This procedure requires the handling of hot, pressurized equipment and materials that are hazardous and can cause injury. Do not exceed manufacturer's safety limits. Only trained personnel shall run these tests.

Detailed operating instructions, as furnished by the equipment manufacturer, are applicable under this method and shall be followed, provided they conform to the procedure contained in this part of ISO 10426.

### 9.4.2 Assembly and filling the slurry container

Prepare and fill the slurry container via the following steps:

- a) clean and lubricate cup threads;
- b) inspect diaphragm;
- c) assemble paddle shaft assembly and secure it in the cup sleeve with flange ring;
- d) make sure the paddle turns freely;
- e) invert the slurry container assembly and fill to within 6 mm (1/4 in) of the top;
- f) strike to remove air;
- g) screw in base plate and make sure slurry is extruded through the centre hole;
- h) screw centre plug (pivot bearing) into the container;
- i) wipe all cement from the outer surfaces;
- j) recheck the paddle to make sure it turns smoothly;
- k) load the slurry container assembly into the consistometer.

NOTE Slurry segregation can occur during the filling operation. This can be reduced by stirring the slurry in the mixing container with a spatula while pouring. Segregation will be less of a problem if the time from cessation of mixing to completing the filling operation is kept to a minimum.

### 9.4.3 Initiation of test

Place the filled slurry container (9.4.2) on the drive table in the pressure vessel, start rotation of the slurry container and secure the potentiometer mechanism so as to engage the paddle shaft drive bar. Begin filling the vessel with oil. At this point, the paddle shaft shall not be rotating.

Next, securely close the head assembly of the pressure vessel, insert the temperature-sensing device through the hole in head assembly and partially engage the threads. After the pressure vessel is completely filled with oil, tighten the threads of the temperature-sensing device.

Begin operating the apparatus 5 min  $\pm$  15 s after cessation of mixing of the slurry as defined in 5.3.4.

### 9.4.4 Temperature and pressure controls

**AC1** During the test period, the temperature and pressure of the cement slurry in the slurry container should be increased in accordance with the appropriate well-simulation test schedule (see 9.5). Schedules may be calculated or taken from the tables. The temperature of the cement slurry shall be determined by use of ASTM classification "Special" Type J thermocouple (see Annex B) located in the centre of the sample container. The tip of the thermocouple shall be vertically positioned, within the paddle shaft, in the slurry cup in such a way that it is between 4,45 cm and 8,89 cm (1,75 in and 3,5 in) above the inside of the base of the sample container. As there are many models of consistometers with different dimensions, care shall be taken to ensure that the thermocouple used is compatible with the consistometer and the position of the tip of the thermocouple is in the correct location, as specified above. **AC1**

### 9.4.5 Thickening time

The thickening time is the time elapsed from the initial application of pressure and temperature to the time at which the slurry reaches a consistency deemed sufficient to make it un-pumpable (e.g. 70  $B_c$  or 100  $B_c$ ). The slurry consistency at which the thickening-time test was terminated shall be documented.

## 9.5 Determination of test schedule

### 9.5.1 General

Well-simulation thickening-time test schedules may be taken from the tables or calculated from equations as described in 9.5.2 to 9.5.4.13. Background and supporting information for these schedules is contained in Annex C.

The schedules in Annex E are based upon nominally vertical wells. The choice of table to use is based upon well depth. The choice of column within a table is based upon thermal gradient.

### 9.5.2 Casing well-simulation schedules

Casing well-simulation thickening-time schedules shall be determined as follows:

- account for surface mixing of the slurry as provided in 9.5.4.1;
- calculate time to displace leading edge of cement slurry to bottom (9.5.4.2);
- calculate bottom-hole pressure (9.5.4.5);
- determine the starting pressure (9.5.4.6);
- calculate pressure-up rate to bottom-hole pressure (9.5.4.7);
- determine the  $T_{\text{BHC}}$  for the specific thermal gradient (Table E.1);
- calculate well simulation heat-up rate by subtracting  $T_{\text{BHC}}$  from ambient temperature and dividing by time to bottom.

Once reached, the final temperature and pressure conditions shall be maintained until the thickening-time test is completed.

### 9.5.3 Liner well-simulation schedules

Liner well-simulation thickening-time schedules shall be determined as follows:

- account for surface mixing of the slurry as provided in 9.5.4.1;
- calculate time to displace leading edge of cement slurry to bottom (9.5.4.2);
- calculate bottom-hole pressure (9.5.4.5);
- determine the starting pressure (9.5.4.6);
- calculate pressure-up rate to bottom-hole pressure (9.5.4.7);
- determine the  $T_{\text{BHC}}$  for the specific thermal gradient (Table E.2);
- calculate well simulation heat-up rate by subtracting  $T_{\text{BHC}}$  from ambient temperature and dividing by time to bottom.

Once reached, the final temperature and pressure conditions shall be maintained until the thickening-time test is completed.

**9.5.4 Calculations for casing and liner schedules**

**9.5.4.1 Surface mixing of the slurry**

If batch mixing is used for the cementing operation, the slurry may be stirred in the consistometer to simulate the time and temperature. The time and slurry surface temperature ( $T_{SS}$ ) may be estimated depending upon the expected conditions at the well site.

The batch mixing simulation is done prior to the start of the thickening-time test. The batch mixing time shall be reported separately from the thickening time of the slurry. For example:

EXAMPLE Simulated batch mixing time: 1 h

Thickening time (does not include batch mixing simulation): 3 h 30 min

**9.5.4.2 Time to displace leading edge of cement slurry to wellbore bottom**

The rate of slurry displacement is calculated as follows:

$$t_d = \frac{V_p}{q} \tag{4}$$

where

$t_d$  is the time to displace the leading edge of cement slurry to bottom, expressed in minutes;

$V_p$  is the volume of the pipe, expressed in cubic metres;

$q$  is the rate at which the fluid slurry is pumped, expressed in cubic metres per minute.

**9.5.4.3 Correlation for predicted bottom-hole circulating temperatures ( $T_{PBHC}$ ) for casing or liner jobs at depths deeper than 3 048 m (10 000 ft)**

The correlation developed for predicting bottom-hole circulating temperatures is given, in degrees Celsius by:

$$T_{PBHC} = \frac{\left[ T_{AS} + \frac{(0,006\ 061 \times h_{TOCTVD} \times \nabla_{PT}) - 10,091\ 5}{1,0 - (0,000\ 015\ 052 \times h_{TOCTVD})} \right] - 32}{1,8} \tag{5}$$

or, in degrees Fahrenheit,

$$T_{PBHC} = T_{AS} + \frac{(0,006\ 061 \times h_{TOCTVD} \times \nabla_{PT}) - 10,091\ 5}{1,0 - (0,000\ 015\ 052 \times h_{TOCTVD})} \tag{6}$$

where

$T_{PBHC}$  is the predicted bottom-hole circulating temperature, expressed in °C [Equation (5)] or °F [Equation (6)];

$T_{AS}$   $\overline{AC_1}$  is the assumed surface temperature of 80 °F  $\overline{AC_1}$  ;

$h_{TOCTVD}$  is the top-of-column true vertical depth, expressed in feet;

$\nabla_{PT}$  is the pseudo-temperature gradient, expressed in °F/100 ft.

NOTE This correlation was developed using constants derived from linear regression analysis of data collected in US Customary units. The correlation using SI units has not been established.

This correlation shall not be used to predict  $T_{PBHC}$  for depths of 3 048 m (10 000 ft) or shallower, because it can give significantly higher  $T_{PBHC}$  than the  $T_{PBHC}$  found in the tables in Annex E. A different correlation is used for the predicted squeeze temperature ( $T_{PS}$ ). This correlation can be found in 9.5.6.1.

Although the  $T_{PBHC}$  correlation is based upon field measurements, there can be error associated with its use for predicting the circulating temperature in a well. The error range between this correlation and the field-measured data from which the correlation was derived is shown in Annex C. The standard deviation is 9,2 °C (16,6 °F). Whenever possible, measurements of downhole temperatures are preferred over calculated estimates.

#### 9.5.4.4 Rate of heat-up to predicted bottom-hole circulating temperature

The temperature of the cement slurry shall be increased from the slurry surface temperature ( $T_{SS}$ ) to the predicted bottom-hole circulating temperature ( $T_{PBHC}$ ) in the time required to displace the leading edge of cement slurry to bottom. The heat-up rate can be calculated using the following equation:

$$R_{\Delta T} = \frac{T_{PBHC} - T_{SS}}{t_d} \quad (7)$$

where

$R_{\Delta T}$  is the rate of temperature change, expressed in °C per minute (°F per minute);

$T_{PBHC}$  is the predicted bottom-hole circulating temperature, expressed in °C (°F);

$T_{SS}$  is the slurry surface temperature, expressed in °C (°F);

$t_d$  is the time to displace the leading edge of cement slurry to bottom, expressed in minutes.

#### 9.5.4.5 Bottom-hole pressure

The bottom-hole pressure can be calculated in SI units (or US Customary units) as follows:

$$p_{BH} = g \times \rho_{df} \times h_{TOCTVD} \quad (8)$$

where

$p_{BH}$  is the bottom-hole pressure, expressed in kilopascals (pounds per square inch);

$g$  is the acceleration of freefall, expressed in metres per second squared (feet per second squared);

$\rho_{df}$  is the density of drilling fluid, expressed in kilograms per cubic metre (pounds per gallon);

$h_{TOCTVD}$  is the top-of-column true vertical depth, expressed in metres (feet).

NOTE The bottom-hole pressure can be calculated to account for contributions of other fluids (spacers, weighted pills, etc.) in the annulus.

#### 9.5.4.6 Starting pressure

The starting pressure ( $p_S$ ) is the estimated pressure to which the leading edge of cement slurry is subjected as it leaves the cementing head.

#### 9.5.4.7 Increase in pressure (pressure-up rate) to bottom-hole pressure

Pressure on the cement slurry shall be increased to the bottom-hole pressure during the test at a pressure-up rate calculated as follows:

$$R_{pu} = \frac{p_{BH} - p_S}{t_d} \quad (9)$$

where:

$R_{pu}$  is the pressure-up rate, expressed in kilopascals per minute;

$p_{BH}$  is the bottom-hole pressure, expressed in kilopascals;

$p_S$  is the starting pressure, expressed in kilopascals;

$t_d$  is the time to displace leading edge of cement to bottom, expressed in minutes.

#### 9.5.4.8 Time at $T_{PBHC}$ and $p_{BH}$

If no measured data are available for the top-of-cement-column temperature ( $T_{TOC}$ ), the  $T_{PBHC}$  and  $p_{BH}$  shall be maintained until the completion of the thickening-time test. Skip steps in 9.5.4.9 to 9.5.4.13 below.

If reliable  $T_{TOC}$  data is available, the cement slurry may be held at the  $T_{PBHC}$  and  $p_{BH}$  for a given period, such as 30 min, as a built-in safety factor. After a holding period at  $T_{PBHC}$  and  $p_{BH}$ , the temperature and pressure on the cement slurry may be changed to the top-of-cement-column temperature ( $T_{TOC}$ ) and pressure ( $p_{TOC}$ ) using steps in 9.5.4.9 to 9.5.4.13.

#### 9.5.4.9 Time to displace the annular volume to be cemented

The time required to displace the annular volume from the bottom of the casing to the top of the annular cement column is calculated as follows:

$$t_a = \frac{V_a}{q} \quad (10)$$

where

$V_a$  is the annular volume, expressed in cubic metres;

$t_a$  is the time to displace the leading edge of cement slurry from bottom of the casing to the top of the annular cement column, expressed in minutes;

$q$  is the fluid pump rate, expressed in cubic metres per minute.

#### 9.5.4.10 Rate of temperature change to $T_{TOC}$

The temperature of the cement slurry may be changed to the  $T_{TOC}$  at a rate calculated by the following equation:

$$R_{\Delta T} = \frac{T_{TOC} - T_{PBHC}}{t_a} \quad (11)$$

where:

$R_{\Delta T}$  is the rate of temperature change to  $T_{TOC}$ , expressed in °C per minute;

$T_{PBHC}$  is the bottom-hole circulating temperature, expressed in °C;

$T_{TOC}$  is top of cement column temperature, expressed in °C;

$t_a$  is the time to displace the leading edge of the cement slurry from bottom of the casing to the top of the annular cement column, expressed in minutes.

NOTE A positive  $R_{\Delta T}$  indicates heat-up; a negative  $R_{\Delta T}$  indicates cool-down.

#### 9.5.4.11 Pressure at the top of cement column

Pressure at the top of the cement slurry column is calculated in SI units (or US Customary units) using the following equation:

$$p_{TOC} = g \times \rho_{df} \times h_{TOCTVD} \quad (12)$$

where:

$p_{TOC}$  is the pressure at the top of the cement column in the annulus, expressed in kilopascals (pounds per square inch);

$g$  is the acceleration of freefall, expressed in metres per second squared (feet per second squared);

$\rho_{df}$  is the density of drilling fluid, expressed in kilograms per cubic metre (pounds per gallon);

$h_{TOCTVD}$  is the true vertical depth at top of cement column, expressed in metres (feet).

The top of cement pressure may be calculated to account for contributions of other fluids (spacers, weighted pills, etc.) in the annulus.

#### 9.5.4.12 Rate of change in pressure down to $p_{TOC}$

The following equation is used to calculate the rate of decrease in pressure (pressure-down rate) from the bottom-hole pressure to the pressure at the top of the cement slurry column:

$$R_{pd} = \frac{p_{BH} - p_{TOC}}{t_a} \quad (13)$$

where

$R_{pd}$  is the rate of pressure change (down), expressed in kilopascals per minute;

$p_{TOC}$  is the pressure at the top of the cement column in the annulus, expressed in kilopascals;

$p_{BH}$  is the bottom-hole pressure, expressed in kilopascals;

$t_a$  is the time needed to displace the leading edge of cement slurry from the bottom of the casing to the top of the annular cement column, expressed in minutes.

#### 9.5.4.13 Completion of test with simulated temperature change

The cement slurry shall be held at the  $T_{TOC}$  temperature and  $p_{TOC}$  pressure until the thickening-time test is completed.



## 9.5.5 Tables of squeeze-cementing schedules

### 9.5.5.1 Continuous-pumping squeeze schedules

Tabular well-simulation thickening-time schedules for continuous-pumping squeeze-cementing operations are provided in Table E.3. Once reached, the final temperature and pressure conditions shown in the schedules shall be maintained until the thickening-time test is completed.

### 9.5.5.2 Hesitation-pumping squeeze schedules

Tabular well-simulation thickening-time schedules for hesitation-pumping squeeze-cementing operations are provided in Table E.4. The differences between the hesitation- and continuous-pumping schedules are that, for hesitation-pumping

- a) there is a second temperature ramp to static temperature, and
- b) stirring of the slurry is cycled on and off during the second temperature ramp.

## 9.5.6 Tailored squeeze schedules

### 9.5.6.1 Correlation to predict squeeze temperatures

The correlation developed for predicting squeeze temperatures, in SI units, is given by:

$$T_{PS} = \frac{\left[ T_{AS} + \frac{(0,007\ 6495 \times h_{TOCTVD} \times \nabla_{PT}) - 8,202\ 1}{1,0 - (0,000\ 008\ 068 \times h_{TOCTVD})} \right] - 32}{1,8} \quad (14)$$

or, for US Customary units:

$$T_{PS} = T_{AS} + \frac{(0,007\ 6495 \times h_{TOCTVD} \times \nabla_{PT}) - 8,202\ 1}{1,0 - (0,000\ 008\ 068 \times h_{TOCTVD})} \quad (15)$$

where

$T_{PS}$  is the predicted bottom-hole squeeze temperature, expressed in °C [Equation (14)] or °F [Equation (15)];

$\nabla_{PT}$  is the pseudo-temperature gradient, expressed in °F per 100 ft;

$h_{TOCTVD}$  is the true vertical depth, expressed in feet;

$T_{AS}$  AC1 is the assumed surface temperature of 80 °F AC1.

NOTE These correlations are valid only for the units shown.

Although the  $T_{PS}$  correlation is based upon field measurements, error can be associated with its use for predicting the squeeze temperature in a well. The error range between this correlation and the field-measured data from which the correlation was derived is shown in Annex C. The standard deviation is 7,2 °C (13 °F). Whenever possible, measurements of downhole temperatures are preferred over calculated estimates.

### 9.5.6.2 Equations for tailored schedules

Equations (5) through (9) under 9.5.4.3 through 9.5.4.7 shall be used for tailored schedules. These equations can be used to calculate the heat-up rate ( $R_{\Delta T}$ ) and pressure-up rate ( $R_{pu}$ ) for a squeeze simulation thickening-time test. In Equation (7), the predicted squeeze temperature,  $T_{PS}$ , shall be substituted for the  $T_{PBHC}$ . After reaching the  $T_{PS}$  and  $p_{BH}$ , the temperature and pressure profiles shall follow the anticipated temperature and pressure profiles for the remainder of the squeeze operation. Additionally, it is recommended that the stirring of the slurry be cycled, using an appropriate sequence, to simulate a hesitation technique if this is anticipated for the squeeze-cementing operation.

### 9.5.7 Plug-cementing tailored schedules

Equations (14) and (15) under 9.5.6.1 can be used for plug-cementing tailored schedules. These equations can be used to calculate the heat-up rate ( $R_{\Delta T}$ ) and pressure-up rate ( $R_{pu}$ ) for a plug-cementing simulation thickening-time test. Because of the short cement columns typically used in plug-cementing, no temperature change or pressure-down rates to the top of the cement column shall be used. Therefore, steps 9.5.4.9 through 9.5.4.13 shall not be used.

## 10 Static fluid-loss tests

### 10.1 General

This clause provides several procedures for running static fluid-loss tests. For tests at temperatures less than or equal to 88 °C (190 °F), testing may be performed using a static fluid-loss cell after slurry conditioning in an atmospheric or pressurized consistometer, or by using a stirred fluid-loss cell. For tests at temperatures greater than 88 °C (190 °F), testing may be performed using a static fluid-loss cell following conditioning in a pressurized consistometer or by using a stirred fluid-loss cell. Regardless of whether the slurry is conditioned in a consistometer or in a stirred fluid-loss cell, the fluid-loss value is determined under static conditions.

### 10.2 Apparatus

**10.2.1 High temperature, high pressure fluid-loss cell** or stirred fluid-loss cell, fitted with a 45 µm (325 mesh) screen with a 22,6 cm<sup>2</sup> (3,5 in<sup>2</sup>) filtration area backed by a 250 µm (60 mesh) screen.

If a screen with a perforated metal back is used, the end caps shall have radial grooves to provide a flow path for the cement filtrate. The screens shall be replaced when they show visible wear, damage or distortion.

The equipment manufacturer's recommendations for maximum temperatures, pressures and volumes should not be exceeded.

**10.2.2 ASTM E220 classification "special" Type J thermocouple**, mounted in the wall of the cell or immersed in the slurry, for measuring the temperature of the cement slurry.

Thermocouples and displays on consistometers and fluid-loss cells shall be calibrated in accordance with Annex B.

The location of the thermocouple shall be noted on the report form. A thermocouple mounted in the heating jacket measures the temperature of the jacket. This temperature is usually higher than the temperature inside the fluid-loss cell.

Metal thermometers shall not be used because of their relatively poor accuracy. Glass thermometers are not used because their dimensions do not allow them to be fitted in the heating jacket or the test cell.

**10.2.3 Pressure gauges**, having a scale such that pressure can be read to ± 300 kPa (± 50 psi).

Gauges shall be calibrated annually.

### 10.3 Safety

These procedures require the handling of hot, pressurized equipment and materials that are hazardous and can cause injury. Only trained personnel shall run these tests.

### 10.4 Mixing procedure

The slurry shall be mixed in accordance with Clause 5.

### 10.5 Conditioning procedures

All slurry conditioning shall start at  $27\text{ °C} \pm 1\text{ °C}$  ( $80\text{ °F} \pm 2\text{ °F}$ ), or at a temperature appropriate for the well conditions, and be heated in accordance with the appropriate schedule.

### 10.6 Procedures for testing at temperatures $\leq 88\text{ °C}$ ( $190\text{ °F}$ )

#### 10.6.1 Atmospheric-pressure conditioning

**10.6.1.1** Within 1 min after mixing, place the slurry into the container of the atmospheric-pressure consistometer.

**10.6.1.2** Heat the slurry to  $T_{PBHC}$  or  $T_{PS}$  in accordance with the thickening-time schedule that most closely simulates actual field conditions. (See optional step 10.6.4.) If the atmospheric-pressure consistometer is not equipped to measure slurry temperature, the bath shall be heated in accordance with the appropriate schedule.

It is preferred that the slurry, and not the bath, be heated in accordance with the appropriate schedule.

**10.6.1.3** After conditioning, remove the paddle and stir the slurry briskly with a spatula to ensure a uniform slurry.

**10.6.1.4** Fill the fluid-loss cell as specified in 10.8.

#### 10.6.2 Pressurized conditioning

**10.6.2.1** Any consistometer referenced in Clause 9 or Annex D may be used. The following procedure applies to the most commonly used equipment.

**10.6.2.2** Place the slurry in the container of the pressurized consistometer in accordance with the procedure in 9.4.

**10.6.2.3** Apply pressure and heat in accordance with the thickening-time schedule which most closely simulates actual field conditions. (See optional step 10.6.4.)

**10.6.2.4** At the end of the schedule, turn off the heaters and release the pressure slowly [about  $1\ 400\text{ kPa/s}$  ( $200\text{ psi/s}$ )].

**10.6.2.5** Remove the slurry container from the consistometer, keeping the container upright so that the oil does not mix with the slurry.

**10.6.2.6** Remove the top locking ring, drive bar and collar from the shaft and the diaphragm cover.

**10.6.2.7** Syringe and blot the oil from the top of the diaphragm.

**10.6.2.8** Remove the diaphragm and the support ring.

**10.6.2.9** Syringe and blot any remaining oil from the top of the slurry. If the contamination is severe, discard the slurry and begin the test again.

**10.6.2.10** Remove the paddle and stir the slurry briskly with a spatula to ensure a uniform slurry.

**10.6.2.11** Fill the fluid-loss cell as specified in 10.8.

### **10.6.3 Stirred fluid-loss cell conditioning**

**10.6.3.1** Prepare the stirred fluid-loss cell in accordance with manufacturer's instructions.

**10.6.3.2** After mixing in accordance with Clause 5, pour the slurry into a clean, dry, stirred fluid-loss cell, in accordance with manufacturer instructions.

**10.6.3.3** Complete the assembly of the fluid-loss cell (screen, O-rings, end cap, etc.).

**10.6.3.4** Apply  $3\,450\text{ kPa} \pm 300\text{ kPa}$  ( $500\text{ psi} \pm 50\text{ psi}$ ) to the cell. Do not close the pressurizing valve.

**10.6.3.5** While agitating with the paddle, heat the slurry in accordance with the thickening-time schedule which most closely simulates actual field conditions.

**10.6.3.6** Once the slurry has reached the specified temperature (and been conditioned for an optional additional period as described in 10.6.4), if required, close the test valve and invert the pressure vessel, reconnect the nitrogen to the top valve and repressurize the nitrogen supply line (if disconnected), and open the top valve slowly.

**10.6.3.7** Apply  $7\,000\text{ kPa} \pm 300\text{ kPa}$  ( $1\,000\text{ psi} \pm 50\text{ psi}$ ) differential pressure to the test cell.

**10.6.3.8** Open the test valve below the screen to begin the test as specified in 10.9.

### **10.6.4 Extra conditioning at test temperature (optional)**

Follow the procedure described in 10.6.1.2, 10.6.2.3 or 10.6.3.6 above, then hold the slurry at the specified temperature and pressure for  $30\text{ min} \pm 30\text{ s}$  or other desired conditioning period before proceeding to the next step. Document the conditioning period used.

## **10.7 Procedures for testing at temperatures > 88 °C (190 °F)**

### **10.7.1 Conditioning using pressurized consistometer**

**10.7.1.1** Any consistometer referenced in Clause 9 or Annex D may be used. The following procedure applies to the most commonly used equipment.

**10.7.1.2** Place the slurry in the container of the pressurized consistometer and begin a thickening-time test in accordance with the procedure in 9.4.

**10.7.1.3** Apply pressure and heat in accordance with the thickening-time schedule which most closely simulates actual field conditions.

**10.7.1.4** At the end of the schedule, turn off the heaters and cool as quickly as practical.

**10.7.1.5** After the slurry has cooled to approximately  $88\text{ °C}$  ( $190\text{ °F}$ ), release the pressure slowly (about  $1\,400\text{ kPa/s}$  ( $200\text{ psi/s}$ )).

**10.7.1.6** Remove the slurry container from the consistometer, keeping the container upright so that oil does not mix with the slurry.

**10.7.1.7** Remove the top locking ring, drive bar and collar from the shaft and the diaphragm cover.

**10.7.1.8** Syringe and blot the oil from the top of the diaphragm.

**10.7.1.9** Remove the diaphragm and the support ring.

**10.7.1.10** Syringe and blot any remaining oil from the top of the slurry. If the contamination is severe, discard the slurry and begin the test again.

**10.7.1.11** Remove the paddle and stir the slurry briskly with a spatula to ensure a uniform slurry.

**10.7.1.12** Fill the fluid-loss cell as specified in 10.8.

**WARNING** Overfilling of this device creates a hazard due to thermal expansion (see Table 4). Do not exceed equipment manufacturer's recommendations for maximum temperatures, pressures and volumes.

**Table 4 — Vapour pressure and volume expansion of water at temperatures between 100 °C (212 °F) and 316 °C (600 °F)**

Temperature °C (°F)	Water vapour pressure kPa (psi)	Coefficient of volume expansion for water at saturation pressure
100 (212)	100 (14,7)	1,04
121 (250)	210 (30)	1,06
149 (300)	460 (67)	1,09
177 (350)	930 (135)	1,12
204 (400)	1 700 (247)	1,16
232 (450)	2 910 (422)	1,21
260 (500)	4 690 (680)	1,27
288 (550)	7 200 (1 044)	1,36
316 (600)	10 620 (1 541)	1,47

## 10.7.2 Conditioning using stirred fluid-loss cell

**10.7.2.1** Prepare the stirred fluid-loss cell in accordance with manufacturer's instructions.

**10.7.2.2** Pour the slurry into a clean, dry, fluid-loss cell following the manufacturer's instructions.

**WARNING** Overfilling of this device creates a hazard due to thermal expansion (see Table 4). Do not exceed equipment manufacturer's recommendations for maximum temperatures, pressures and volumes.

**10.7.2.3** Complete the assembly of the stirred fluid-loss cell (screen, O-rings, end cap, etc.) in accordance with manufacturer's instructions.

**10.7.2.4** Apply and maintain  $3\,500\text{ kPa} \pm 300\text{ kPa}$  ( $500\text{ psi} \pm 50\text{ psi}$ ) (or sufficient pressure to prevent the fluid from boiling at the maximum test temperature as listed in Table 4) to the cell. Do not close the pressurizing valve.

**10.7.2.5** While agitating with the paddle, heat the slurry in accordance with the thickening-time schedule which most closely simulates actual field conditions. Monitor pressures closely to prevent over-pressurizing the cell.

**10.7.2.6** Once the slurry has reached the specified temperature (and been conditioned for an optional period as described in 10.6.4), stop stirring, close the pressurizing valve, invert the pressure vessel, reconnect the nitrogen and repressurize the nitrogen supply line (if disconnected), and open the top valve slowly.

**10.7.2.7** Connect the back-pressure receiver or condenser to the test valve below the screen. If a back-pressure receiver is used, apply sufficient pressure to the back-pressure receiver to prevent the cement filtrate from boiling at the test temperature (Table 4).

**10.7.2.8** Apply  $7\,000\text{ kPa} \pm 300\text{ kPa}$  ( $1\,000\text{ psi} \pm 50\text{ psi}$ ) differential pressure to the pressure vessel.

**10.7.2.9** Open the test valve below the screen and begin the test as specified in 10.9.

## 10.8 Filling the static fluid-loss cell

**10.8.1** Prepare the fluid-loss cell. It shall be ready to be filled when the slurry conditioning period has been completed. It shall be clean and dry.

**10.8.2** Preheat the fluid-loss cell to the test temperature of  $88\text{ °C} \pm 3\text{ °C}$  ( $190\text{ °F} \pm 5\text{ °F}$ ) for tests at  $88\text{ °C}$  ( $190\text{ °F}$ ) or greater.

**10.8.3** With the test pressure supply valve closed, pour the slurry into the fluid-loss cell to  $2,5\text{ cm} \pm 0,6\text{ cm}$  ( $1\text{ in} \pm \frac{1}{4}\text{ in}$ ) below the shoulder on which the screen rests in the  $12,7\text{ cm}$  ( $5\text{ in}$ ) cell, or  $5,1\text{ cm} \pm 0,6\text{ cm}$  ( $2\text{ in} \pm \frac{1}{4}\text{ in}$ ) below the shoulder in the  $25,4\text{ cm}$  ( $10\text{ in}$ ) cell.

**WARNING** Overfilling of this device creates a hazard due to thermal expansion (see Table 4).

**10.8.4** Place the screen and O-rings in the cell, secure the end cap in the cell. Apply pressure of  $3\,500 \pm 300\text{ kPa}$  or  $500\text{ psi} \pm 50\text{ psi}$ . Do not close the test valve.

### 10.8.5 Heating (non-stirred cell)

**10.8.5.1** For tests at temperatures  $\leq 88\text{ °C}$  ( $190\text{ °F}$ ), start the test as quickly as possible, but no more than 6 min shall elapse from the time of completion of conditioning to the start of the test (opening the bottom valve, 10.9.1). Completion of conditioning is the end of the heat-up schedule (plus optional extra conditioning).

**10.8.5.2** For tests at temperatures  $> 88\text{ °C}$  ( $190\text{ °F}$ ), heat the fluid-loss cell to the test temperature as fast as the heating jacket will heat. No more than 6 min shall elapse from the time of completion of conditioning to the start of heating. Completion of conditioning is the end of the heat-up schedule (plus optional extra conditioning) and cooling. Record the time to reach the test temperature.

**NOTE** In order for the slurry to reach the test temperature, it is sometimes necessary to set the controller temperature higher than the desired test temperature.

**10.8.6** Close the fluid-loss cell top valve, bleed the pressure from the supply line and disconnect the nitrogen line.

**10.8.7** Invert the cell so that the screen is on the bottom.

**10.8.8** Attach the back-pressure receiver (or condenser) to the outlet stem. If a back-pressure receiver is used, apply sufficient pressure to the back-pressure receiver to prevent the cement filtrate from boiling at the test temperature (Table 4).

**10.8.9** Connect the nitrogen line and apply a differential pressure of  $7\,000\text{ kPa} \pm 300\text{ kPa}$  ( $1\,000\text{ psi} \pm 50\text{ psi}$ ). Open the top fluid-loss cell valve to apply and maintain  $7\,000\text{ kPa} \pm 300\text{ kPa}$  ( $1\,000\text{ psi} \pm 50\text{ psi}$ ) differential pressure to the cell.

## 10.9 Fluid loss test

**10.9.1** Open the bottom valve to start the test within 30 s of inverting the cell. Maintain at the specified temperature for the duration of the test.

**10.9.2** Collect the filtrate and record the volume to an accuracy of  $\pm 1$  ml at 30 s, 1 min, 2 min, 5 min, 7,5 min, 10 min, 15 min, 25 min and 30 min. Alternatively, the filtrate may be continuously weighed and recorded. If weighed, measure and report the filtrate relative density at 27 °C (80 °F) and correct the recorded filtrate volumes for relative density. When a condenser is used, the filtrate volume in the condenser shall be accounted for.

The “Fluid Loss Results Reporting Form” at the end of Clause 10 may be used for recording data and other pertinent information about the test.

**10.9.3** If nitrogen blows through at less than 30 min, record the volume collected and time at which the blowout occurs. Close all valves to the cell and turn off the heater.

**10.9.4** Calculate the ISO Fluid Loss, expressed as millilitres per 30 min. For tests that run the entire 30 min without “blowing out”, measure the collected filtrate volume, double the value and report it as the fluid loss value. For tests that “blow out” in less than the 30 min test interval, use Equation (16) to calculate the ISO Fluid Loss.

$$\text{Calculated ISO Fluid Loss} = V_t \frac{10,944}{\sqrt{t}} \quad (16)$$

where

$V_t$  is the volume of filtrate collected at the time of the blowout, expressed in millilitres;

$t$  is the time of the blowout, expressed in minutes.

**10.9.5** When reporting the fluid loss of cement slurries, those for which the fluid loss was measured for a full 30 min shall be reported as “ISO Fluid Loss” while those for which the fluid “blew out” in less than 30 min shall be reported as “Calculated ISO Fluid Loss.”

## 10.10 Test completion and clean-up

**10.10.1** Cool the cell to a safe handling temperature and release the pressure.

**WARNING** Pressure can be trapped inside the cell, even if the valve stems are open or removed.

**10.10.2** After ensuring that all the pressure is released, disassemble the cell, and inspect the screen to check for holes or damage. If there is damage to the O-ring seals or screen, discard the test results and rerun the test.

**10.10.3** Carefully clean the screen to remove cement or additive residue from fluid loss.

**10.10.4** Clean and dry the fluid-loss cell in preparation for the next test. Pay particular attention to the O-rings in the cell and on the valve stems.

NOTE 1 Slurries with significant sedimentation give erroneous values for fluid loss.

NOTE 2 Fluid loss tests which do not run a full 30 min have a potential error which becomes greater as the length of the test becomes shorter.

NOTE 3 Fluid loss tests that run the full 30 min typically show 5 % variability. Tests that run less than 5 min can have a variability of more than 30 %.

Form for reporting fluid loss results

Heat-up schedule: \_\_\_\_\_ minutes to \_\_\_\_\_ °C (°F) Test temperature [\_\_\_\_\_ °C (°F)/min]

Conditioning method [ ] Atmospheric [ ] Pressurized [\_\_\_\_\_ kPa, (psi)]

[ ] Stirred fluid-loss cell

[ ] Optional extra conditioning \_\_\_\_\_ minutes

Static cell length [ ] 12,7 cm (5 in) [ ] 25,4 cm (10 in)

Cell type (ends) [ ] Double [ ] Single

Screen type [ ] 325 mesh × 60 mesh

[ ] 325 mesh × 60 mesh with perforated metal back

Time (min)	Filtrate ([ ] ml or [ ] g)	Time (min)	Filtrate ([ ] ml or [ ] g)
1/2	_____	10	_____
1	_____	15	_____
2	_____	25	_____
5	_____	30	_____
7 1/2	_____		

If filtrate weighed, relative density : \_\_\_\_\_ at 26,7 °C (80 °F)

API fluid loss = \_\_\_\_\_ ml/30 min

Blowout = \_\_\_\_\_ ml (or g) at \_\_\_\_\_ min/s

Calculated API fluid loss = \_\_\_\_\_ ml/30 min

Filter cake conditions = Thickness<sup>a</sup> \_\_\_\_\_ Consistency<sup>b</sup> \_\_\_\_\_

Time from end of conditioning to test start = \_\_\_\_\_ min

Temperature = Start of test \_\_\_\_\_ °C (°F)

End of test \_\_\_\_\_ °C (°F)

Location of thermocouple = [ ] Cell wall [ ] In slurry

Date of calibration of sensors =

	Consistometer	Fluid-loss cell
Pressure gauge	_____	_____
Thermocouple	_____	_____

<sup>a</sup> Thickness : of cake only; do not include remaining slurry if gelled.

<sup>b</sup> Consistency : hard, firm, mushy, gelled, etc.



## 11 Permeability tests

### 11.1 General

This procedure shall be used to determine the relative permeability of a set cement sample to liquids or gases. Test results can be used to enhance the design of cement slurry formulations, however they do not always provide an accurate indication of the actual permeability of a set cement under subterranean wellbore conditions.

### 11.2 Apparatus

#### 11.2.1 Cement (or core) permeameter, capable of

- a) confining a set cement sample in a sample holder assembly;
- b) displacing gas or liquid through the sample under pressure;
- c) measuring or recording the pressure and rate of flow of fluid through the sample.

There are a variety of permeameters available which can be used to perform this test. The equipment designs may be somewhat different, but their component parts and basic operating functions are similar. A cement permeameter shall include the devices described in 11.2.2, 11.2.3 and 11.2.4.

#### 11.2.2 Sample holder assembly

There are several types of sample holder assembly which can be used to confine a set cement sample, depending on the type of permeameter used for this test. Some recommended types of holder assembly are listed below:

##### a) Moulded-sample holder

The cement sample is cured in a mould of brass or stainless steel having a height of 25,40 mm (1,0 in), an inside diameter tapered from 29,31 mm (1,154 in) at the bottom to 27,94 mm (1,102 in) at the top, an outside diameter of 50,80 mm (2,0 in), and a 5,23 mm (0,206 in) by 45° bevelled top and bottom edges. This mould is then placed in the sample holder assembly of the cement permeameter and the moulded cement sample sealed in the holder assembly.

##### b) Cored-sample holder

The cement slurry is cured in a 50,8 mm × 50,8 mm (2,0 in × 2,0 in) compressive strength mould (or other suitable mould). A cylindrical sample is then prepared by coring the set cement with a 25,4 mm (1,0 in) ID diamond core drill. Water or air is used to lubricate the drill bit while coring the 25,4 mm (1,0 in) OD cement sample. The cement sample is then cut to 25,4 mm (1,0 in) length using a diamond core saw so that the ends of the sample are parallel and as perpendicular to the sides of the sample as possible.

The ends of the cored cement sample are then cleaned of any residue. The sample is placed inside a rubber core holder (Figure 9). The rubber core holder and cement sample is then placed inside the core holder assembly and secured and confined in the permeameter such that no pressurized gas or liquid can bypass the cement sample during testing.

#### 11.2.3 Pressure medium, such as compressed air, nitrogen, or any other safe and adequate means of maintaining constant gas pressure.

For gas permeability tests, the gas is transmitted under pressure directly through the cement sample.

For liquid permeability tests, the gas pressure shall be applied to a liquid-filled accumulator system (rubber bladder, tank, sealed piston reservoir, cylinder, etc.) which, in turn, displaces a liquid out of the accumulator through the cement sample. Constant gas pressure shall ensure a constant liquid flow rate into the cement sample. Alternative fluid delivery systems such as constant rate pumps may also be used.

#### **11.2.4 Measuring or recording device**

The flow rate of gas may be measured using a “ball” type flow meter or an electronic mass-flow meter. The flow rate of liquid may be measured using a flow meter (rotameter), electronic mass-flow meter, or other appropriate means. Flow rate shall be measured in millilitres per second.

When using the electronic mass-flow meter with liquid, the liquid shall be collected inside a closed, sealed reservoir on the downstream side of the specimen which, in turn, will displace air out of the reservoir through the mass-flow meter.

### **11.3 Sample preparation**

#### **11.3.1 General**

Prior to curing, prepare the cement slurry and curing mould as directed in either 11.3.2 or 11.3.3.

#### **11.3.2 Slurry**

##### **11.3.2.1 For moulded samples**

Pour the cement slurry, prepared in accordance with Clause 5, into a clean, ungreased, cement permeameter mould which has been placed on a flat plate and sealed around the exterior with a thin film of grease. Puddle the cement slurry 27 times with a stirring rod and level it with a spatula or straightedge. Carefully place a top plate on the mould so as not to trap air bubbles in the sample. Then cure the moulded sample in accordance with the curing procedure outlined in Clause 7.

##### **11.3.2.2 For cored samples**

Prepare the cement slurry in accordance with Clause 5. Then transfer the slurry into moulds prepared for compressive-strength test, and cure in accordance with the procedure outlined in Clause 7.

#### **11.3.3 Set cement**

##### **11.3.3.1 For moulded samples**

After the cement slurry has cured under the desired test conditions, remove the mould containing the sample from the curing chamber or water bath. Remove the cover plates and cool the sample under water to room temperature. Clean the sample by scraping under a stream of water to remove any residue prior to testing. A soft wire brush, emery cloth or knife blade may be used for removing residue.

##### **11.3.3.2 For cored samples**

After the cement slurry has cured under the desired test conditions, remove the mould containing the sample from the curing chamber or water bath. Remove the cover plates, cool the set cement under water to room temperature and remove from the mould. Then core the set cement in accordance with the procedure outlined in 11.2.2 b).

### **11.4 Liquid permeability (cement permeameter)**

**11.4.1** Prior to testing, saturate the sample with water. Keep the sample immersed in water until the time of testing. Seal the mould in the sample holder assembly with its larger face downward. Tighten the assembly to assure an O-ring seal at the top and bottom of the cement sample. To prevent collection of any air in the water and under the sample, the procedure described in 11.4.2 through 11.4.8 is recommended.

**11.4.2** With mercury in the system as shown (see Figure 9), valve A closed, valves B, C, and D opened, connect an aspirator bottle containing recently boiled, deaerated and filtered (using an 0,15 µm ceramic filter) water to valve C. Fill the water chamber until water over flows through valve D.

**11.4.3** With valves B, C and D closed and valve A opened, adjust the air regulator to obtain the desired pressure drop across the cement sample by observing pressure gauge G [generally 100 kPa to 1 400 kPa (20 psi to 200 psi)].

**11.4.4** Connect the aspirator bottle to valve E.

**11.4.5** With the aspirator bottle 305 mm to 610 mm (12 in to 24 in) higher than valve E, open valves D and E slightly to allow a small flow of water past the mould containing the set cement as the holder cap is screwed into place.

**11.4.6** Close valve E and fully open valve D.

**11.4.7** Connect an aspirator bottle to valve F, open valve F slightly, and allow water to flow over top of the sample and up the stem of the pipette to obtain a reference starting point.

**11.4.8** Flow water through the sample for a minimum of 15 min or until about 1 ml has been forced through the sample into the measuring tube. During this period, measure the flow rate and differential pressure at least twice.

### **11.5 Alternative procedure (core permeameter) for liquid permeability**

**11.5.1** Prior to testing, saturate the sample with water. Keep the sample immersed in water until the time of testing. Place a cored cement sample in a rubber core holder and, in turn, in a core-holder assembly (Figure 10). Then seal the cement sample in the permeameter by means of mechanical or gas confining pressure applied to the core-holder assembly.

**11.5.2** Fill the liquid accumulator in the core permeameter with deaerated, filtered (using 0,15 µm ceramic filter) deionized water.

**11.5.3** With the air regulator backed off, and all valves closed on the permeameter, apply gas pressure [2 068 kPa to 3 447 kPa (300 psi to 500 psi)] to the permeameter.

**11.5.4** Leaving valves A (gas test valve) and F closed, open valves B, C, and D to the liquid side of the permeameter, and trap valve E.

**11.5.5** Slowly increase pressure with the regulator, as observed on gauge G, until a steady stream of liquid begins to flow out of valve D above the core-holder assembly.

**11.5.6** Close valve D to divert flow through the cement sample. Increase pressure indicated on gauge G to read between 100 kPa and 1 400 kPa (20 psi and 200 psi) or until flow is observed on the downstream side of the cement sample at valve E. Close valve E to divert the flow through the flow-meter assembly.

The slowest measurable flow rate shall be used to measure permeability. High differential pressures and large flow rates can provide erroneous measurements.

**11.5.7** When the flow rate has stabilized, record the inlet pressure as indicated on gauge G ( $p_i$ ) and flow rate ( $q$ ) in millilitres per second. When completed, relieve pressure on the regulator and slowly open valves D and E to relieve any pressure in the system. Remove the cement sample.

In either case, "unsteady state" permeability is observed as an increase or decrease in differential pressure and flow rate across the core sample at constant drive pressure. "Steady state" permeability occurs when the differential pressure and flow rate remain steady at constant drive pressure. Only steady state measurements are valid.

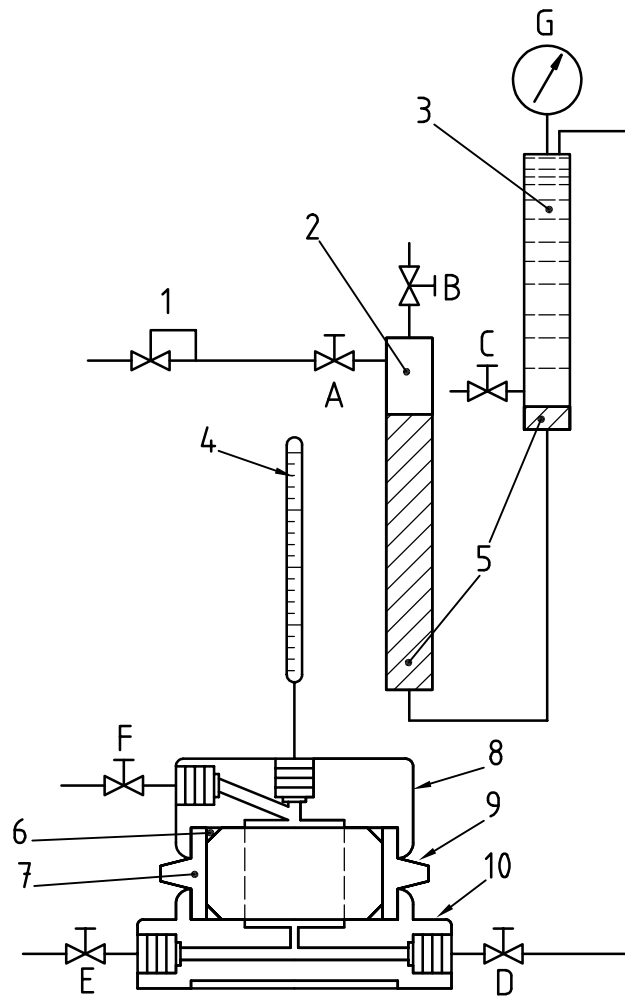
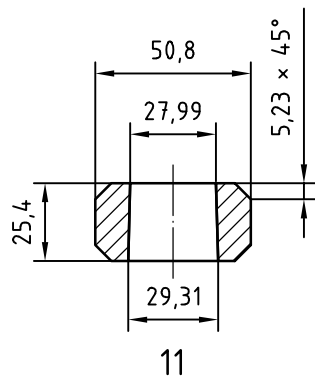

**Key**

- 1 pressure regulator
- 2 air
- 3 water
- 4 pipette measuring tube
- 5 mercury
- 6 O-ring
- 7 mould (see detail)
- 8 holder cap
- 9 holder cylinder
- 10 holder base
- 11 mould detail

A, B, C, D, E, F valves (see text)

G pressure gauge

**Figure 9 — Cement permeameter**

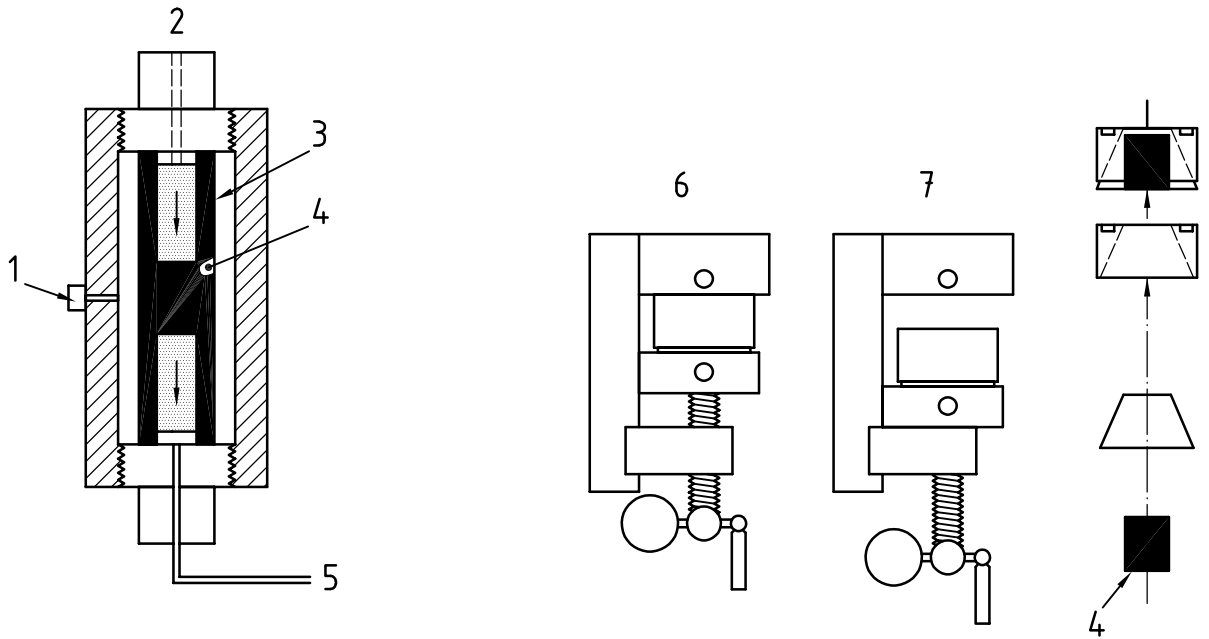

a) Hassler sleeve assembly hydraulic seal

b) Tapered sleeve assembly mechanical seal

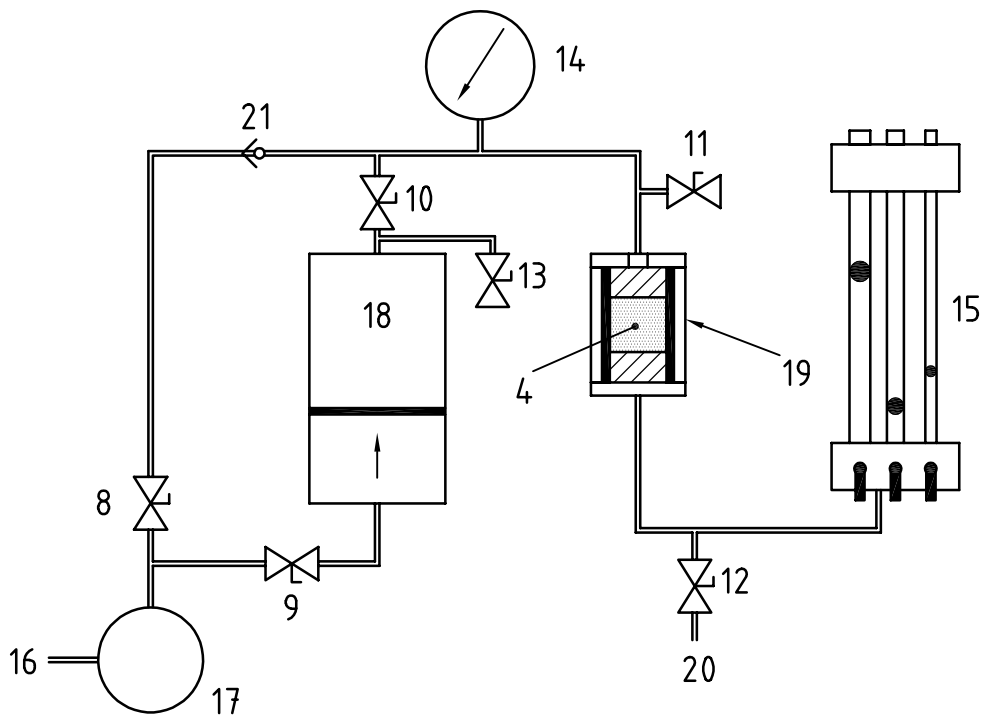

c) Assembled permeameter

<b>Key</b>	6	closed position	12	trap valve (E)	17	regulator	
1	confining pressure	7	open position	13	Fill valve (F)	18	liquid accumulator
2	fluid inlet	8	gas test valve (A)	14	inlet pressure (G)	19	core-holder assembly
3	rubber sleeve	9	liquid test valve (B)	15	flow meters	20	tube to drain
4	cement sample	10	valve (C)	16	gas inlet	21	check valve
5	tube to flow meter	11	bleed valve (D)				

Figure 10 — Liquid/gas core permeameter

## 11.6 Calculating liquid permeability

Calculate the liquid permeability  $K$  of the set cement using Darcy's Law, as given in Equation (17) (SI units of square micrometres) or Equation (18) (USC units of millidarcies). The curing temperature, curing pressure and curing time shall also be reported with the permeability measurement.

$$K = 10^5 \frac{q \cdot \mu \cdot L}{A \cdot \Delta p} \quad (17)$$

where, for SI units:

- $K$  is the permeability, expressed in square micrometres;
- $q$  is the flow rate, expressed in millilitres per second;
- $\mu$  is the liquid viscosity, expressed in pascal seconds;
- $L$  is the sample length, expressed in centimetres;
- $A$  is the cross-sectional area, expressed in centimetres squared;
- $p_i$  is the inlet pressure, expressed in kilopascals;
- $p_o$  is the outlet pressure, expressed in kilopascals;
- $\Delta p$  is  $(p_i - p_o)$ , expressed in kilopascals.

or, for USC units:

$$K = 14\,700 \frac{q \cdot \mu \cdot L}{A \cdot \Delta p} \quad (18)$$

- $K$  is the permeability, expressed in millidarcies;
- $q$  is the flow rate, expressed in millilitres per second;
- $\mu$  is the liquid viscosity, expressed in centipoise;
- $L$  is the sample length, expressed in centimetres;
- $A$  is the cross-sectional area, expressed in centimetres squared;
- $p_i$  is the inlet pressure, expressed in pounds per square inch;
- $p_o$  is the outlet pressure, expressed in pounds per square inch;
- $\Delta p$  is  $(p_i - p_o)$ , expressed in pounds per square inch.

## 11.7 Gas permeability (core permeameter)

**11.7.1** Prior to testing, dry the sample to constant mass in a drying oven or desiccator. This procedure may be used to determine the permeability of the cement sample to gas. This test can be used to quickly screen cement samples to enhance the design of extremely low permeability formulations.

**11.7.2** Prepare the sample and load into the core permeameter as outlined in 11.5.

**11.7.3** With the air regulator backed off, and all valves closed on the permeameter, apply gas pressure [2 050 Pa to 3 500 Pa (300 psi to 500 psi)] to the permeameter.

**11.7.4** Leaving valves B and C (liquid test valves) closed, open valves A and D to the gas side of the permeameter.

**11.7.5** Slowly increase pressure with the regulator until the lines have been purged of all liquid, and gas is slowly bleeding out of valve D above the core-holder assembly.

**11.7.6** Close valve D to divert the gas flow through the cement sample. Increase the pressure indicated on gauge G until a flow rate is observed at the flow-meter assembly. Be sure valve E is closed. Once the flow rate has stabilized, record the inlet pressure on gauge G ( $p_i$ ) and flow rate ( $q$ , in millilitres per second).

**11.7.7** Once the readings are taken, relieve the pressure at the regulator, open bleed valves D and E to make sure no pressure is trapped in the permeameter, and remove the cement sample.

### 11.8 Calculating gas permeability

Calculate the gas permeability  $k$  of the set cement using Darcy's Law, as given in Equation (19) in SI units of square micrometres (USC units of millidarcies). The curing temperature, curing pressure and curing time shall also be reported with the permeability measurement.

$$k = \frac{2\,000 \times \mu \times q_b \times p_b \times L}{A \times (p_i^2 - p_o^2)} \quad (19)$$

where:

$k$  is the permeability to gas, expressed in square micrometres (millidarcies);

$\mu$  is the viscosity of gas, expressed in pascal seconds (centipoise);

$q_b$  is the flow rate of gas, expressed in millilitres per second;

$p_b$  is the adjusted barometric pressure, expressed in kilopascals (standard atmospheres);

$L$  is the cement sample length, expressed in centimetres;

$A$  is the cross-sectional area, expressed in centimetres squared;

$p_i$  is the inlet pressure, expressed in kilopascals (standard atmospheres);

$p_o$  is the outlet pressure, expressed in kilopascals (standard atmospheres);

## 12 Determination of rheological properties and gel strength using a rotational viscometer

### 12.1 General

The purpose of this procedure is to characterize the rheological behaviour of cement slurries. Determination of rheological properties of cement slurries can be sensitive to the procedure being used. Therefore, a comparison of rheological properties of cement slurries obtained using different procedures is not recommended.

A standardized procedure has been developed to generate reproducible results for the oil industry. This procedure was developed after a careful analysis of many parameters which affect the rheological behaviour of cement slurries. The large majority of data was accumulated using non-dispersed slurries; however, data from some dispersed slurries were also evaluated. The results of the analysis showed that highly dispersed slurries will generally yield data of less quality with this procedure, because of possible settling while running the test.

### 12.2 Apparatus

#### 12.2.1 Rotational viscometer

##### a) Calculation of shear stress and shear rate

With this type of viscometer, the sample is confined between two concentric cylinders of radii  $R_1$  and  $R_2$  ( $R_2 > R_1$ ), one of which, the rotor, is rotating at a constant rotational speed,  $n_r$ . The rotation of the rotor in the presence of the sample produces a torque that is usually measured at the wall of the inner cylinder, but is also prevalent on the outer cylinder wall. The cylinder radii shall be such that the sample is homogeneous and the shear stress is as uniform as possible across the gap. These conditions are assumed to be satisfied if:

$$\left( \frac{R_1}{R_2} \right) > 0,9 \quad (20)$$

and

$$R_2 - R_1 > 10 \times \varnothing \quad (21)$$

where  $\varnothing$  is the diameter of the largest sample particle.

The nominal shear rate,  $\gamma$ , is calculated at the inner cylinder wall by the following expressions:

$$\boxed{\text{AC1}} \gamma = \frac{2 \times R_2^2 \times n_r}{R_2^2 - R_1^2} \boxed{\text{AC1}} \quad (22)$$

$$\gamma = \frac{\pi}{15} \times \frac{R_2^2 \times n_r}{R_2^2 - R_1^2} \quad (23)$$

where

$\gamma$  is the nominal shear rate, expressed in reciprocal seconds;

$n_r$   $\boxed{\text{AC1}}$  is the viscometer rotational speed, expressed in radians per second [Equation (22)] or revolutions per minute [Equation (23)]  $\boxed{\text{AC1}}$ ;

$R_1, R_2$  are the radii of the concentric cylinders ( $R_2 > R_1$ ), in metres (inches).



and the shear stress,  $\tau$ ,

$$\tau = \frac{T}{2 \times \pi \times R_1^2} \quad (24)$$

$$\tau = 1,44 \frac{T}{2 \times \pi \times R_1^2} \quad (25)$$

where

$\tau$  is the shear stress, expressed in pascals (pounds force per square inch);

$T$  is the torque per unit length, expressed in newtons (pound-force);

$R_1$  is the radius of the inner cylinder, in metres (inches).

The following assumptions were used in the derivation of Equations (22), (23), (24) and (25).

- The slurry is homogeneous and the shear stress is uniform in the gap.
- The flow regime in the annular gap is laminar.
- Slip at the wall is negligible.
- The fluid exhibits essentially time-independent behaviour.

The rotational viscometer shall be capable of measuring shear stress at shear rates in the range from near zero to at least as high as  $511 \text{ s}^{-1}$ . Typically used instruments provide a minimum of five readings in that range. Instruments providing less than five readings in that shear rate range are not recommended.

#### b) Description and specifications of a typical rotational viscometer

This viscometer is a direct-indicating instrument powered by a motor with or without a speed reduction gear box. The outer cylinder or sleeve is driven at a constant rotational velocity for each r/min (rev/s) setting. The rotation of the sleeve on the cement slurry produces a torque on the inner cylinder or bob. A torsion spring restrains the movement of the bob and a dial attached to the torsion spring indicates the displacement of the bob.

##### 1) Characteristics of the sleeve:

inside diameter 36,83 mm (1,450 in);

total length may vary slightly with manufacturer;

scribed line 58,4 mm (2,30 in) above bottom;

two rows of 3,18 mm ( $1/8$  in) holes, spaced 2,09 radians ( $120^\circ$ ) apart, around rotor sleeve and centred 3,2 mm ( $1/8$  in) and 9,6 mm ( $3/8$  in) below the scribed line.

##### 2) Characteristics of the bob:

diameter 34,49 mm (1,358 in);

cylinder length 38,00 mm (1,496 in);

closed, with a flat base and tapered top with a cone semi-angle of  $60^\circ$ .

When using this instrument, nominal shear rate and shear stress can be calculated from the instrument's raw data by using the expressions:

$$\gamma = 16,28 \times n_r \quad (\text{SI}) \quad (26)$$

$$\gamma = 1,705 \times n_r \quad (\text{USC}) \quad (27)$$

and

$$\tau(\text{Pa}) = 0,5099 \times F \times \theta \quad (\text{SI}) \quad (28)$$

$$\tau = 1,065 \times F \times \theta \quad (\text{USC}) \quad (29)$$

where

- $\gamma$  is the nominal shear rate, expressed in reciprocal seconds;
- $n_r$  is the viscometer rotational speed, expressed in revolutions per second (revolutions per minute);
- $\tau$  is the shear stress, expressed in pascals (pounds force per 100 square feet);
- $\theta$  is the viscometer reading, expressed in instrument degrees;
- $F$  is the instrument's torsion spring factor.

#### **12.2.2 Stopwatch or electric timer.**

**12.2.3 Thermometer or thermocouple**, capable of measuring temperature within  $\pm 0,5$  °C ( $\pm 1$  °F).

### **12.3 Calibration**

Calibration procedures for a given viscometer shall be followed as suggested by the manufacturer to assure the repeatability of the measurements.

- a) Proper operation of a direct-indicating viscometer depends, among other things, upon maintenance of the correct spring tension. Procedures for testing spring tension by a simple deadweight method or by measuring Newtonian fluids of known viscosity at specific temperatures are available from manufacturers. Rotational speeds shall be checked with a tachometer. In addition, it is important to make sure that when empty, the instrument reads zero when rotating at any speed.
- b) Although typically used instruments are generally provided with a torsion spring having a spring factor  $F = 1$  as standard, other torsion springs are available for measuring fluids having lower or higher viscosity. Each time the torsion spring is changed, the instrument shall be recalibrated. When the instrument is equipped with a torsion spring having a spring factor  $F \neq 1$ , the dial readings obtained shall be multiplied by the appropriate factor,  $F$ .
- c) The bob-sleeve assembly shall be checked for centralization before using the instrument. This shall be done by turning on the instrument and placing a small mirror underneath the bob-sleeve assembly. Severe non-centralization shall be corrected.

### **12.4 Determination of rheological properties**

The procedure below is recommended when using pressurized viscometers [for measurements above 88 °C (190 °F)] or atmospheric viscometers. For safety reasons, do not use atmospheric viscometers at temperatures above 88 °C (190 °F). Deviations from this procedure for pressurized viscometers shall only be made as required due to equipment characteristics.

Clean and dry the instrument (bob, sleeve and cup) before each test.

- a) Prepare the cement slurry in accordance with Clause 5, with the following exceptions.
  - 1) Check the blades of the blender for wear and replace as recommended in 5.2.3. (If water leakage occurs around the bearings, replace the entire blender-blade assembly.)
  - 2) When needed, add antifoam agent to the mix water before adding the solids to the water, to minimize foaming.
- b) Pour the prepared cement slurry immediately into the slurry container of an atmospheric or a pressurized consistometer for preconditioning. The slurry container shall be initially at ambient temperature, as this can avoid the possibility of thermally shocking temperature-sensitive additives. The slurry may then be heated to the desired test temperature, up to 88 °C (190 °F) in the atmospheric consistometer, or to the desired elevated temperature and pressure in a pressurized consistometer, and to the appropriate thickening-time test schedule for the cementing application.

With slurries that are not affected by thermal shock, the slurry container may be pre-heated [ $\pm 2$  °C ( $\pm 5$  °F)] at the test temperature or any other initial temperature selected by the operator, before pouring the slurry into the slurry container.

- c) After the desired preconditioning temperature (and pressure) has been reached, stir the cement slurry for a period of 20 min. If preconditioning is done in a pressurized consistometer, cool the slurry down as rapidly as possible to 88 °C (190 °F), or to the test temperature if less than 88 °C (190 °F), before releasing the pressure from the consistometer. The pressurized consistometer can then be safely opened.

Blot from the top of the slurry any oil which may have invaded the pressurized consistometer cup during the preconditioning period.

After the oil is blotted, remove the slurry paddle and stir the slurry vigorously with a spatula for 5 s to re-disperse all the solids which may have settled to the bottom of the cup.

- d) Immediately pour the cement slurry into the viscometer cup to the fill line. Maintain the viscometer cup, bob and sleeve at the test temperature  $\pm 2$  °C ( $\pm 5$  °F) for the duration of the test, by using a heated cup assembly large enough to allow good temperature control. As indicated above, the maximum test temperature for an atmospheric viscometer shall not exceed 88 °C (190 °F). During steps 12.4 c) and 12.4 d), make every effort to prevent the slurry from remaining static for any period of time.
- e) With the sleeve rotating at the lowest speed, raise the preheated cup until the liquid level is at the inscribed line on the sleeve. This operation minimizes slurry gellation and ensures uniform distribution of the slurry.
- f) Record the temperature of the slurry in the viscometer cup before taking the first reading. Take the initial instrument dial reading 10 s after continuous rotation at the lowest speed. Take all the remaining readings first in ascending order, and then in descending order, after continuous rotation of 10 s at each speed. Shifting to the next speed shall be done immediately after taking each reading. The recommended highest reading shall be taken at a shear rate (equivalent speed) of about 511 s<sup>-1</sup>. Exposing cement slurries to shear rates above 511 1/s has been reported to generate inconsistent results. If desired, after ramping up and down and after measuring the gel strength (12.5), readings at shear rates greater than 511 s<sup>-1</sup> may be taken. After taking all the readings, again record the temperature of the slurry in the viscometer cup.

NOTE Repeatability of data taken at shear rates at and below 10,2 s<sup>-1</sup> is often poor. At the discretion of the operator, readings at and below 10,2 s<sup>-1</sup> may be omitted from the test, except when measuring gel strength (12.5).

- g) Calculate the ratio of the ramp-up to ramp-down readings at each speed. This ratio can be used to help qualify certain slurry properties, as follows.
- 1) When the ratio at all the speeds is close to 1, this may suggest that the slurry is a non-settling, time-independent fluid at the average test temperature.
  - 2) Ratios mostly higher than 1 may suggest settling of the slurry at the average test temperature. In addition, if some ramp-down readings at the same rotational speed are lower by more than 5 instrument degrees (obtained with the viscometer in 12.2.1 b) with a spring factor  $F = 1$ ), this may be a further indication of the possibility of settling.
  - 3) Ratio values mostly lower than 1 may suggest gelling of the slurry.

When significant differences in the readings indicate that the cement slurry is not stable, i.e. prone to extreme settling or excessive gellation, adjustments in the slurry composition shall be considered.

- h) Report the slurry rheological measurements as the average of the readings [(ramp-up + ramp-down)/2], at the average of the temperatures recorded in Step 12.4 f). An example is shown in Table 5.

**Table 5 — Example of data from a rheological properties test**

Rotational speed r/s	Ramp-up reading	Ramp-down reading	Reading ratio	Average reading
3	21	24	0,87	22,5
6	40	36	1,11	38
30	65	83	0,78	74
60	84	100	0,84	92
100	100	115	0,87	107,5
200	137	147	0,93	142
300	170			170
Initial slurry temperature = 66 °C (150 °F)				
Final slurry temperature = 63 °C (146 °F)				
Rheological properties reported at average temperature 65 °C (148 °F)				

- i) For improved reliability of the measurements, the entire procedure may be repeated 2 or 3 times using a freshly prepared slurry each time. Each instrument reading shall then be reported as the average of all the acceptable measurements.

### 12.5 Determination of gel strength

The gel strength of a cement slurry may be measured immediately after determining the rheological properties of the slurry sample, or as an independent observation. If increasing slurry gelation is observed during the rheological measurements, a brief reconditioning of the slurry in the viscometer for 1 min at 300 r/s may disperse the gels and allow better measurement of the gel strength. For all independent tests, prepare, condition and load the slurry into the viscometer as outlined in 12.4 a) through 12.4 e).

Gel strength shall then be determined as follows.

- a) Shut off the viscometer for 10 s and record the slurry temperature.

- b) Set the viscometer at the speed equivalent to  $5,1 \text{ s}^{-1}$  and start rotation. Record the maximum observed reading immediately after turning on the instrument. Use this reading to calculate the 10 s gel strength using Equation (28).
- c) Shut off the viscometer for 10 min and record the slurry temperature. Repeat the measurements as in 12.5 b). to report the 10 min gel strength.
- d) After taking the readings, again record the temperature of the slurry in the viscometer cup.
- e) Report the slurry gel strengths at the average of the recorded temperatures.
- f) For improved reliability of the measurements, the entire procedure may be repeated 2 times or 3 times using a freshly prepared slurry each time. Report the gel strength values as the average of the acceptable measurements.

## 12.6 Modelling of the rheological behaviour

### 12.6.1 General

To be able to characterize the flow behaviour (friction pressures, flow regime, etc.) of the cement slurry in any geometry (pipe, annulus, etc.), a rheological model that best represents the data shall be selected. To do this, convert the raw data obtained (rotational velocities and torque readings) to shear rate and shear stress using Equations (22), (23), (24) and (25). Simplified equations (26), (27), (28) and (29) may be used when the viscometer in 12.2.1 b) is being used. A rheological model for the fluid can then be selected by a regression analysis or by plotting the shear rate vs. shear stress data.

The following assumptions were made to develop the equations that appear in this clause:

- a) the fluid is homogeneous;
- b) slip at the wall is negligible;
- c) the fluid exhibits essentially time-independent behaviour;
- d) the flow regime is laminar.

### 12.6.2 Rheological models

#### 12.6.2.1 General

Rheological models describe the relationship between shear stress and shear rate of a fluid. The most commonly used models to describe the rheological properties of cement slurries are the Bingham Plastic and the Power Law Models.

#### 12.6.2.2 Bingham Plastic Model

When plotting shear stress versus shear rate on Cartesian (rectangular) coordinates, a cement slurry behaving as a Bingham Plastic results in a straight line with a positive shear stress at zero shear rate (Figure 11, Curve D). For this model, the shear stress is related to the shear rate by the relationship:

$$\tau = \tau_0 + (\mu_p \times \dot{\gamma}) \quad (30)$$

where

$\tau$  is the shear stress, expressed in pascals (pounds force per 100 square feet);

$\tau_0$  is the positive shear stress at zero shear rate, expressed in pascals (pounds force per 100 square feet);

$\mu_p$  is the proportionality constant, expressed in pascal seconds;

$\gamma$  is the shear rate, expressed in reciprocal seconds.

In Equation (30),  $\tau_0$  is referred to as yield stress or yield point (often denoted as YP). Above the yield point, the shear stress of the fluid is proportional to the shear rate, and the proportionality constant  $\mu_p$  is referred to as the plastic viscosity (often denoted as PV). If in Equation (30) the yield point is equal to zero, the equation then becomes the relationship for the simplest of all rheological models, the Newtonian fluid model (Figure 11, Curve A).

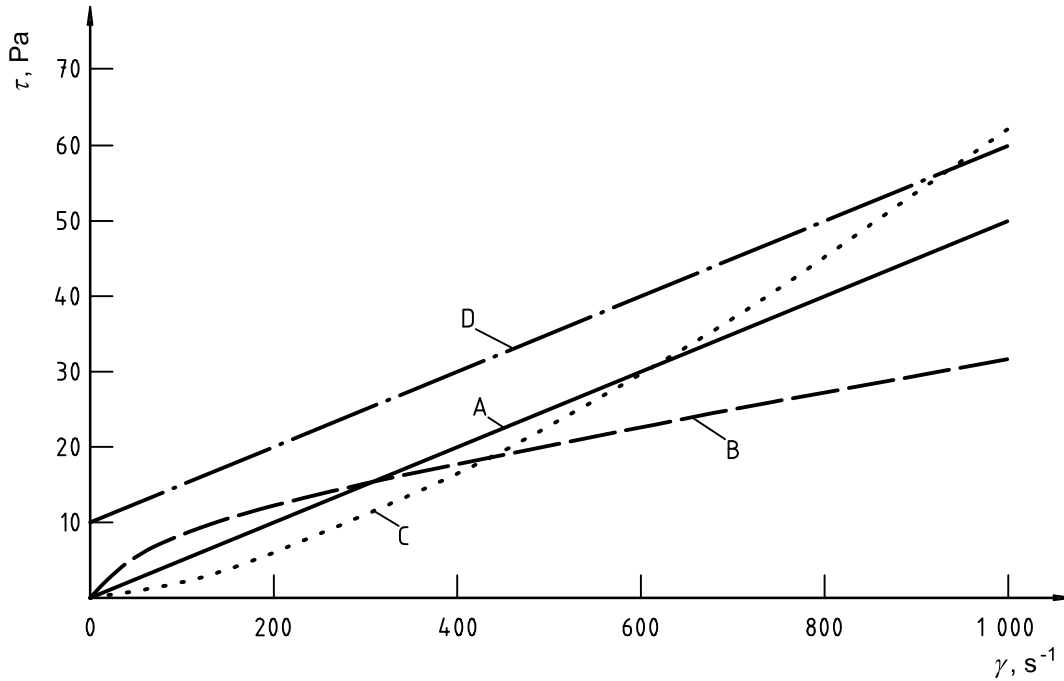

**Key**

- A Newtonian behaviour
- B Power Law ( $n < 1$ ) behaviour
- C Power Law ( $n > 1$ ) behaviour
- D Bingham Plastic behaviour

**Figure 11 — Illustration of shear stress-shear rate behaviour of various fluids on a linear plot**

**12.6.2.3 Power Law Model**

When plotting shear stress versus shear rate on Cartesian (rectangular) coordinates, this model produces a curve with zero shear stress at zero shear rate (Figure 11, Curves B and C). When plotting shear stress versus shear rate on log-log paper, a cement slurry behaving as a Power Law fluid results in a straight line (Figure 12, Curves B and C). For this model, the shear stress is related to the shear rate by the relationship:

$$\tau = k \times \gamma^n \tag{31}$$

where

$\tau$  is the shear stress, expressed in pascals (pounds force per 100 square feet);

$k$  is the consistency index (a constant), expressed in pascal seconds to the power of  $n$  ( $\text{Pa} \cdot \text{s}^n$ ) [100 pounds force seconds to the power of  $n$  per 100 square feet ( $100 \text{ lbf} \cdot \text{s}^n / 100 \text{ ft}^2$ )];

$\dot{\gamma}$  is the shear rate, expressed in reciprocal seconds;

$n$  is the Power Law flow behaviour index (Ostwald index).

In Equation (31), for shear-thinning (pseudo-plastic) fluids,  $n$  is a positive number between zero and 1 (Figure 11, Curve B). Cement slurries normally exhibit pseudo-plastic behaviour. For shear-thickening (dilatant) fluids,  $n$  is a positive number greater than one (Figure 11, Curve C). Cement slurries normally do not exhibit dilating behaviour. If in Equation (31)  $n$  is equal to 1, the equation then conforms to the Newtonian fluid model (Figure 11, Curve A).

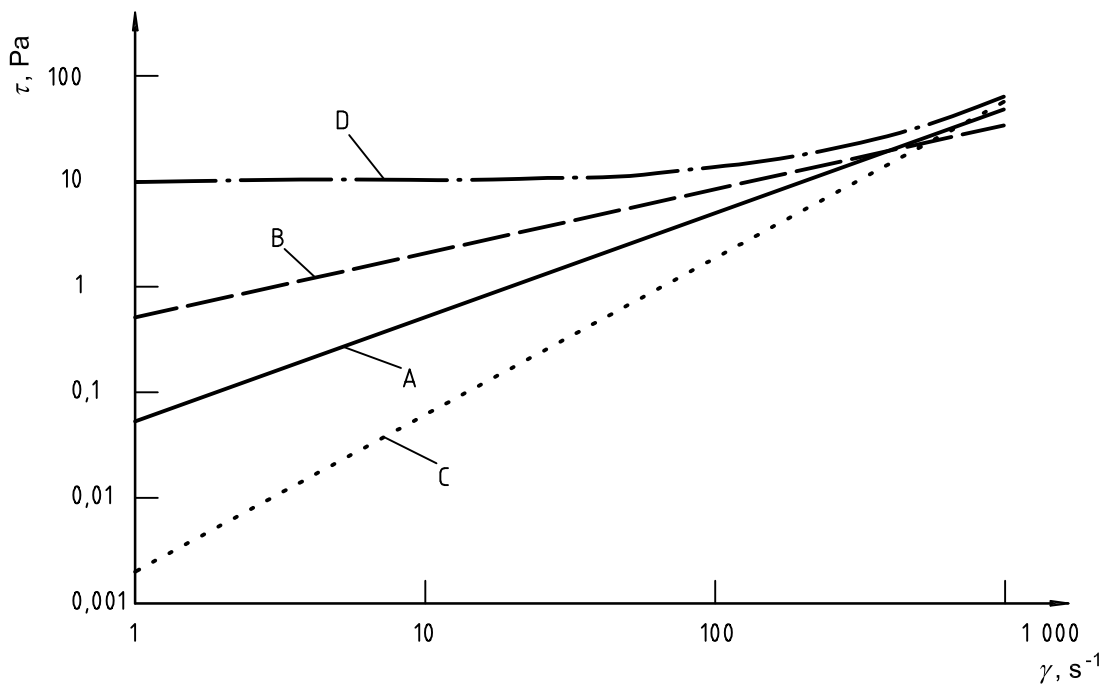

#### Key

- A Newtonian behaviour
- B Power Law ( $n < 1$ ) behaviour
- C Power Law ( $n > 1$ ) behaviour
- D Bingham Plastic behaviour

**Figure 12 — Illustration of shear stress-shear rate behaviour of various fluids on a log-log plot**

### 12.6.3 Selecting a rheological model

#### 12.6.3.1 General

The shear stress, shear rate data of the cement slurry shall be analysed according to Equations (30) and (31) to make a decision about which model best fits the data. This can best be done by performing a regression analysis on the data. The model with the best regression coefficient shall be selected as the model describing the data.

#### 12.6.3.2 Bingham Plastic Model

A regression analysis shall be performed using Equation (30) to determine the slope  $A$  and the intercept  $B$ . If shear stresses  $\tau$  are expressed in pascals (SI units) or pound-force per square inch (USC units) and shear rates  $\dot{\gamma}$  are expressed in reciprocal seconds, the Bingham Plastic parameters  $\mu_p$  and  $\tau_0$  can be derived from:

$$\mu_p = A \quad (\text{SI}) \quad (32)$$

$$\mu_p = 478,8 \times A \quad (\text{USC}) \quad (33)$$

$$\tau_0 = B \quad (\text{SI and USC}) \quad (34)$$

A negative calculated yield point is an indication that either the cement slurry has tendencies to settle, or the cement slurry may be gelling up while its rheological properties are being measured. If this happens, it is recommended that the slurry be re-mixed and its rheological properties re-measured. If the problem persists, the cement slurry could present problems downhole, and its use shall be reconsidered.

### 12.6.3.3 Power Law Model

Here, the parameters are obtained using regression analysis on the logarithmic form of Equation (31) with slope  $C$  and intercept  $D$ :

$$\log_{10} \tau = \log_{10} k + n \log_{10} \gamma \quad (35)$$

Regardless of the unit system, the flow behaviour index  $n$  can be derived directly from the slope  $C$ :

$$n = C \quad (36)$$

If shear stresses  $\tau$  are expressed in pascals and shear rates  $\gamma$  are expressed in reciprocal seconds, the consistency index,  $k$ , in Pa·s <sup>$n$</sup>  can be derived from the intercept  $D$  using:

$$k = 10^D \quad (\text{SI}) \quad (37)$$

If shear stresses  $\tau$  are expressed in lbf/in<sup>2</sup> and shear rates  $\gamma$  are expressed in reciprocal seconds, the consistency index,  $k$ , in lbf·s <sup>$n$</sup> /ft<sup>2</sup> can be derived from the intercept  $D$  using:

$$k = 0,01 \times 10^D \quad (\text{USC}) \quad (38)$$

## 12.6.4 The “two-point” method

### 12.6.4.1 General

If a regression analysis cannot be performed, a less accurate “two-point” method may be used. With this method, two data points from the shear-stress, shear-rate raw data are selected to calculate the parameters of the models. A better way to select two data points to use with this method is to plot the shear-stress, shear-rate data on Cartesian (rectangular) coordinates for the Bingham Plastic Model, and on log-log paper for the Power Law Model. After that, the “best” straight line is drawn through the data points. Two data points are then chosen on the line, and used to calculate the parameters. From these two data points, the parameters can be obtained as described in 12.6.4.2 and 12.6.4.3.

### 12.6.4.2 Bingham Plastic Model

For this method using the Bingham Plastic Model, where the subscripts <sub>1</sub> and <sub>2</sub> refer to the two selected data points, the shear stresses  $\tau$  in pascals (SI units) or pounds force per 100 square feet (USC units), and shear rates  $\gamma$  in reciprocal seconds for both unit systems, the plastic viscosity  $\mu_p$  and yield point  $\tau_0$  are calculated as follows:

$$\mu_p = \frac{\tau_2 - \tau_1}{\gamma_2 - \gamma_1} \quad (\text{SI}) \quad (39)$$



or

$$\mu_p = 478,8 \times \frac{\tau_2 - \tau_1}{\gamma_2 - \gamma_1} \quad (\text{USC}) \quad (40)$$

and

$$\tau_o = \tau_2 - \left( \gamma_2 \times \frac{\tau_2 - \tau_1}{\gamma_2 - \gamma_1} \right) \quad (\text{SI or USC}) \quad (41)$$

If the viscometer described in 12.2.1 b) is being used, and if the cement slurry is truly behaving as a Bingham Plastic fluid, the following simple expressions may be used:

$$\mu_p = 0,00150 \times F (\theta_{300} - \theta_{100}) \quad (\text{SI}) \quad (42)$$

$$\mu_p = 1,50 \times F (\theta_{300} - \theta_{100}) \quad (\text{USC}) \quad (43)$$

and

$$\tau_o = 0,4788 (F \times \theta_{300} - 1000 \times \mu_p) \quad (\text{SI}) \quad (44)$$

$$\tau_o = F (\theta_{300} - \mu_p) \quad (\text{USC}) \quad (45)$$

where

$\theta_{300}$  is the instrument's reading at 300 r/min;

$\theta_{100}$  is the instrument's reading at 100 r/min.

A better choice is to use data points selected at the denoted revolutions per minute, from the best straight line drawn through the raw data points on a Cartesian plot of revolutions per minute versus instrument readings.

#### 12.6.4.3 Power Law Model

For the Power Law Model, the parameters using the “two-point” method can be obtained as follows:

$$n = \frac{\log_{10} (\tau_2 / \tau_1)}{\log_{10} (\gamma_2 / \gamma_1)} \quad (46)$$

and

$$k = \frac{\tau_1}{\gamma_1^n} = \frac{\tau_2}{\gamma_2^n} \quad (\text{SI}) \quad (47)$$

$$k = 0,01 \times \frac{\tau_1}{\gamma_1^n} = 0,01 \times \frac{\tau_2}{\gamma_2^n} \quad (\text{USC}) \quad (48)$$

If the viscometer described in 12.2.1 b) is being used, and if the cement slurry is truly behaving as a Power Law fluid, the following simple expressions may be used:

$$n = 2,096 \times \log_{10} (\theta_{300} / \theta_{100}) \quad (49)$$

and

$$k = (F \times \theta_{300}) \times \frac{511^n}{0,4788} \tag{SI} \tag{50}$$

$$k = (F \times \theta_{300}) \times (100 \times 511^n) \tag{USC} \tag{51}$$

Again, the preferred way to obtain the instrument's readings for the last two equations is from the best straight line drawn through the raw data points on a log-log plot of r/min versus instrument readings.

**12.6.5 Examples**

Two examples are given below illustrating the selection of the best model for the given measured data.

EXAMPLE 1 The following data were obtained using the procedure outlined in this part of ISO 10426:

Velocity r/min	Reading <i>F</i> = 1	Shear rate s <sup>-1</sup>	Shear stress Pa	Shear stress (lbf/100 ft <sup>2</sup> )
3	4	5,11	2,04	4,26
6	7	10,2	3,57	7,45
30	27	51,1	13,70	28,70
60	51	102	25,00	54,30
100	78	170	39,80	83,10
200	143	340	72,80	152
300	200	511	102	213

Figures 13 and 14 show a comparison of the data plotted on Cartesian and on log-log coordinates. The figures suggest that a Power Law Model may be used for the data. From a regression analysis, the correlation coefficient for the Power Law Model was 1,000. For the Bingham Plastic, it was 0,996. The rheological parameters for the Power Law Model from the regression analysis were in this case:

<i>n</i>	<i>k</i> Pa·s <sup><i>n</i></sup>	<i>k</i> (lbf·s <sup><i>n</i></sup> /ft <sup>2</sup> )
0,854	0,494	0,010 3

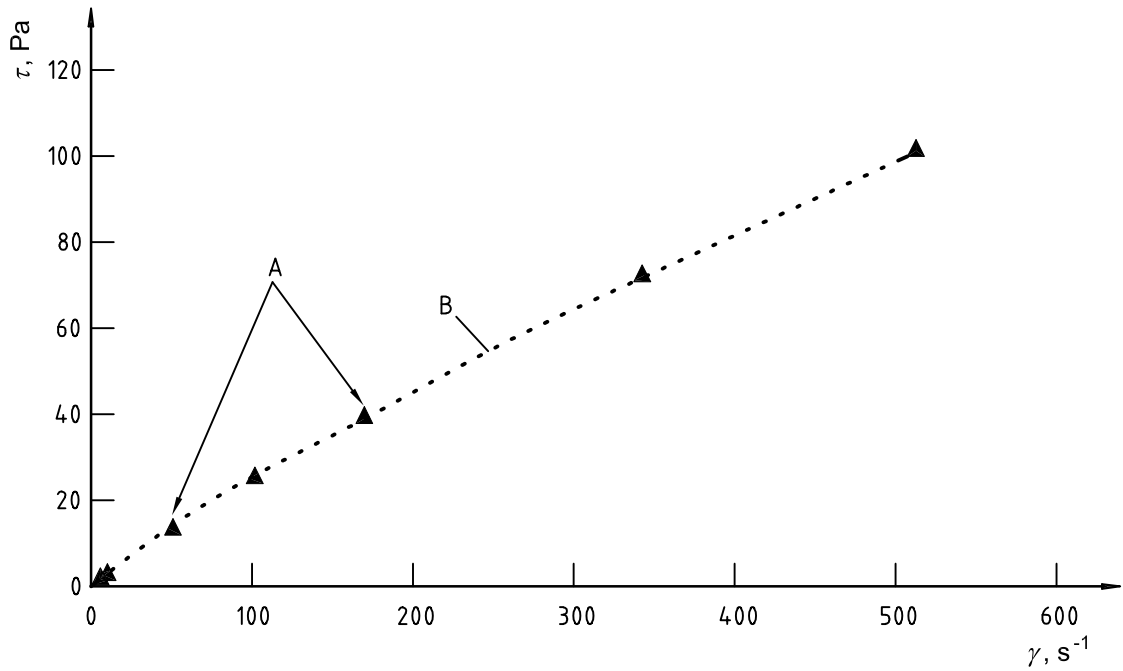

**Key**

- A Data
- B Model

Figure 13 — A linear plot of shear stress vs. shear rate for Example 1

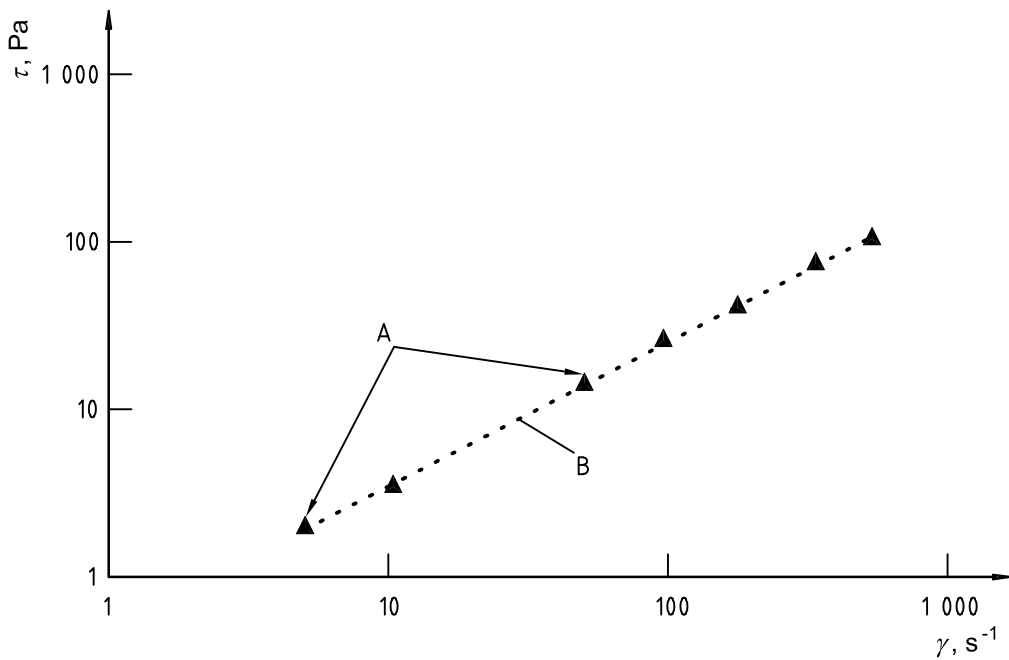

**Key**

- A Data
- B Model

Figure 14 — Logarithmic plot of shear stress vs. shear rate for Example 1

EXAMPLE 2

Velocity r/min	Reading $F = 1$	Shear rate $s^{-1}$	Shear stress Pa	Shear stress (lbf/100 ft <sup>2</sup> )
3	56	5,11	28,5	59,6
6	60	10,2	30,6	63,9
30	84	51,1	42,9	89,5
60	109	102	55,5	116
100	140	170	71,3	149
200	200	340	102	213
300	260	511	133	277

Figures 15 and 16 show that these data best fit a Bingham Plastic Model. This was verified using regression analysis. The correlation coefficients were 0,992 for the Bingham Plastic Model and 0,937 for the Power Law Model. The rheological parameters for the Bingham Plastic Model from the regression analysis were:

$\tau_0$ Pa	$\tau_0$ (lbf/100ft <sup>2</sup> )	$\mu_p$ Pa·s	$\mu_p$ (cp)
29,7	62,0	0,204	204

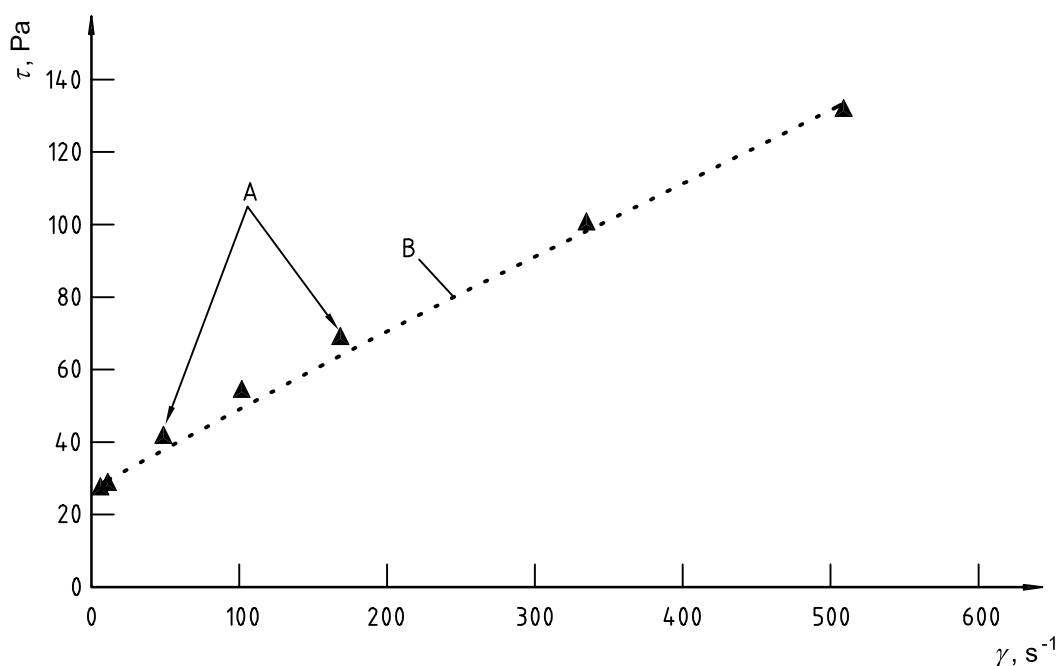

**Key**  
 A Data  
 B Model

Figure 15 — Linear plot of shear stress vs. shear rate for Example 2

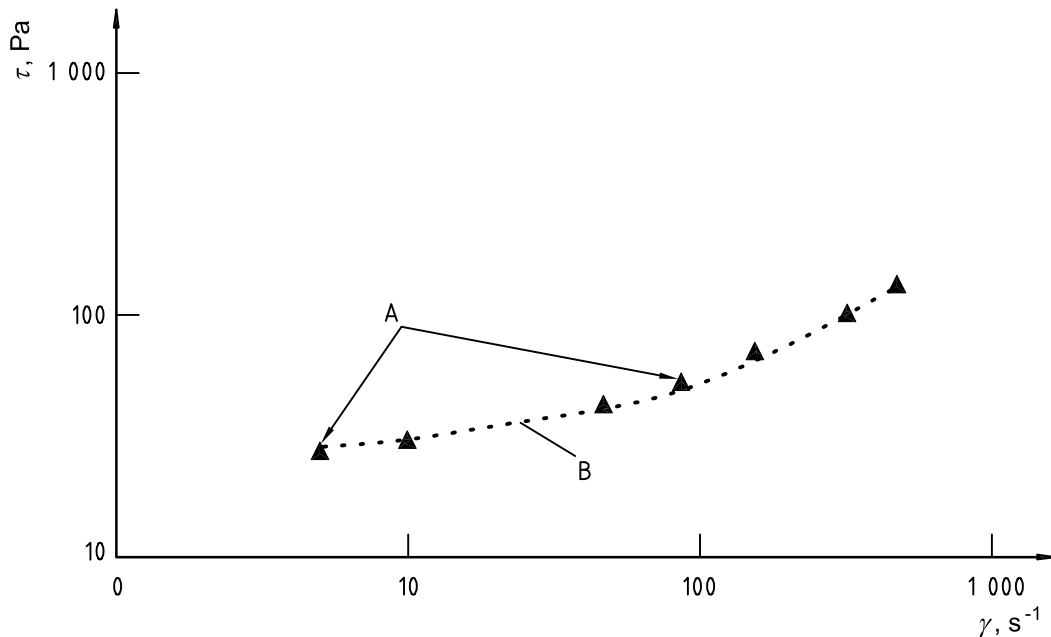

#### Key

- A Data
- B Model

Figure 16 — Logarithmic plot of shear stress vs. shear rate for Example 2

## 13 Calculation of pressure drop and flow regime for cement slurries in pipes and annuli

### 13.1 General

#### 13.1.1 Background

Selection of the rheological model which best fits the slurry rheology data is required to calculate the flow behaviour of a cement slurry in any wellbore geometry. The procedure for rheological model selection is presented in 12.6.

The following equations can be used for calculating pressure drop and flow regime for cement slurries in casing and concentric annuli. Shear rates and shear stresses change as wellbore geometries and annular tolerances change, with varying degrees of eccentricity. Also slurry behaviour is altered with changing wellbore sizes, surfaces, annular tolerances, temperatures and velocities. Rheological properties can also be affected by solid or fluid contamination of the slurry downhole, or by water loss to the surrounding formation which may increase the solids to liquid ratio. The equations given in this clause outline a procedure to estimate pressure drop and flow regime in a concentric annulus by using the rheological data from a rotational viscometer. Due to the complexity of equations needed to address eccentric annuli, they are not included in this procedure, however good computer models are available for this purpose. References in which such models are discussed are included in this clause.

#### 13.1.2 Assumptions

The following assumptions are made in these calculations:

- the fluid is assumed to be time-independent, its rheology is supposed to be well described either by a Newtonian, a Power Law or Bingham Plastic Model;

- the fluid is assumed to be homogeneous;
- the fluid temperature is assumed to be homogeneous;
- the flow is fully developed;
- for annular flow, it is assumed that the geometry is concentric.

For annular flow, we give two sets of equations. One is the pipe approximation which applies to annuli with low diameter ratios, i.e.  $d_a/D_a$  ( $d_a$  and  $D_a$  being the inner and outer diameters of the annulus, respectively). The other is the narrow slot approximation, which applies to annuli with diameter ratios typically higher than 0,3. In fact the diameter ratio can be taken into account but it leads to equations which are more complicated.

### 13.1.3 Pertinent equations

In the equations that follow in this part of ISO 10426, the multiplier  $K$  is a unit conversion constant. It has appropriate subscripts, for example:  $v$  for velocity.

To simplify the flow equations presented below, the fluid mean velocity, symbol  $v$ , is used rather than the fluid volumetric flow rate, symbol  $q$ . The relationship between these two parameters is as follows. Factors for conversion from SI to USC units are included in 13.5.

#### a) Relationship between fluid mean velocity and fluid volumetric flow rate

##### 1) Pipe flow

$$v = \frac{4q}{\pi \times d_p^2} \quad (52)$$

$$q = \frac{\pi \times d_p^2}{4} \times v \quad (53)$$

##### 2) Annular flow

$$v = \frac{4q}{\pi \times (D_a^2 - d_a^2)} \quad (54)$$

$$q = \frac{\pi \times (D_a^2 - d_a^2)}{4} \times v \quad (55)$$

where

- $v$  is the fluid mean velocity, expressed in metres per second;
- $q$  is the volumetric flow rate, expressed in cubic metres per second;
- $d_p$  is the inner diameter of the pipe, expressed in metres;
- $d_a$  is the inner diameter of the annulus, expressed in metres;
- $D_a$  is the outer diameter of the annulus, expressed in metres.

## b) Friction pressure gradients

Friction pressure gradients,  $\Delta p/L$ , will be calculated from the relationship between at least two dimensionless groups: the Reynolds number  $Re$ , and the friction factor  $f$ .

Once the friction factor is known, the friction pressure gradient can be determined from:

### 1) Pipe flow

$$\frac{\Delta p}{L} = \frac{2\rho v^2 f}{d_p} \quad (56)$$

### 2) Annular flow

$$\frac{\Delta p}{L} = \frac{2\rho v^2 f}{(D_a - d_a)} \quad (57)$$

where:

$\Delta p/L$  is the friction pressure gradient, expressed in pascals per metre (Pa/m);

$\Delta p$  is the friction pressure, expressed in pascals;

$L$  is the length of a pipe or an annulus, expressed in metres;

$\rho$  is the fluid density, expressed in kilograms per cubic metre;

$v$  is the fluid mean velocity, expressed in metres per second;

$f$  is the friction factor, the ratio of the wall shear stresses to kinetic energy per volume;

$d_p$  is the inner diameter of the pipe, expressed in metres;

$d_a$  is the inner diameter of the annulus, expressed in metres;

$D_a$  is the outer diameter of the annulus, expressed in metres.

The following clauses discuss how the friction factor is calculated for Newtonian, Power Law and Bingham Plastic fluids.

## 13.2 Newtonian fluids

### 13.2.1 Equations

For a Newtonian fluid, the Reynolds number,  $Re$ , is defined as:

#### a) Pipe flow, Reynolds number

$$Re = \frac{\rho v d_p}{\mu} \quad (58)$$

**b) Annular flow, Reynolds number**

$$Re = \frac{\rho v (D_a - d_a)}{\mu} \quad (59)$$

where

- $Re$  is the Reynolds number of a Newtonian fluid;
- $\rho$  is the density, expressed in kilograms per cubic metre;
- $v$  is the fluid mean velocity, expressed in metres per second;
- $d_p$  is the inner diameter of the pipe, expressed in metres;
- $d_a$  is the inner diameter of the annulus, expressed in metres;
- $D_a$  is the outer diameter of the annulus, expressed in metres.
- $\mu$  is the viscosity, expressed in pascal seconds (Pa·s).

Therefore the fluid mean velocity for a given value of the Reynolds number can be calculated from:

**c) Pipe flow, fluid mean velocity**

$$v = \frac{\mu Re}{\rho d_p} \quad (60)$$

**d) Annular flow, fluid mean velocity**

$$v = \frac{\mu Re}{\rho (D_a - d_a)} \quad (61)$$

where

- $Re$  is the Reynolds number;
- $\rho$  is the density, expressed in kilograms per cubic metre;
- $v$  is the fluid mean velocity, expressed in metres per second;
- $d_p$  is the inner diameter of the pipe, expressed in metres;
- $d_a$  is the inner diameter of the annulus, expressed in metres;
- $D_a$  is the outer diameter of the annulus, expressed in metres;
- $\mu$  is the viscosity, expressed in pascal seconds (Pa·s).



Depending on the value of the Reynolds number, the flow regime is classified as follows:

Flow regime	Pipe flow	Annular flow
Laminar	$Re \leq 2\,100$	$Re \leq 2\,100$
Transitional	$2\,100 < Re < 3\,000$	$2\,100 < Re < 3\,000$
Turbulent	$Re \geq 3\,000$	$Re \geq 3\,000$

The critical fluid mean velocity for turbulent flow,  $v_c$ , is given by:

**e) Pipe flow, critical fluid mean velocity**

$$v_c = \frac{3\,000 \times \mu}{\rho d_p} \tag{62}$$

**f) Annular flow, critical fluid mean velocity**

$$v_c = \frac{3\,000 \times \mu}{\rho (D_a - d_a)} \tag{63}$$

where

- $v_c$  is the critical value of  $v$ , expressed in metres per second;
- $\rho$  is the density, expressed in kilograms per cubic metre;
- $d_p$  is the inner diameter of the pipe, expressed in metres;
- $d_a$  is the inner diameter of the annulus, expressed in metres;
- $D_a$  is the outer diameter of the annulus, expressed in metres.
- $\mu$  is the viscosity, expressed in pascal seconds (Pa·s).

**g) Friction factor, laminar flow**

In laminar flow the friction factor,  $f$ , can be calculated from the following equations:

**1) Pipe flow and annular flow — Pipe**

$$f = \frac{16}{Re} \tag{64}$$

**2) Annular flow — Slot**

$$f = \frac{24}{Re} \tag{65}$$

where

- $f$  is the friction factor;
- $Re$  is the Reynolds number.

**h) Friction factor, turbulent flow**

In turbulent flow, whatever the flow geometry, the friction factor can be calculated from the following equation:

$$\frac{1}{\sqrt{f}} = 4,0 \times \log_{10} (Re \sqrt{f}) - 0,4 \quad (66)$$

where

$f$  is the friction factor;

$Re$  is the Reynolds number.

In transitional flow, a log-log approximation is performed between  $Re = 2\,100$  and  $Re = 3\,000$ .

**13.2.2 Example of calculations**

**13.2.2.1 EXAMPLE 1**

What is the critical flow rate for turbulent flow, in cubic metres per second, for a Newtonian fluid with a density of  $1\,008 \text{ kg/m}^3$  and a viscosity of  $1,8 \times 10^{-3} \text{ Pa}\cdot\text{s}$  flowing in a pipe of inner diameter  $d$   $0,059 \text{ m}$ ? The critical velocity for turbulent flow is given by:

$$v_c = \frac{3\,000 \times (1,8 \times 10^{-3})}{1\,008 \times 0,059} = 0,090\,8 \text{ m/s}$$

This gives a critical flow rate of:

$$q_c = \frac{\pi \times 0,059^2}{4} \times 0,090\,8 = 0,248 \times 10^{-3} \text{ m}^3/\text{s}$$

What is the friction pressure, in pascals, over  $500 \text{ m}$  for the same fluid flowing at  $0,015 \text{ m}^3/\text{s}$ ? Its velocity is:

$$V = \frac{4 \times 0,015}{\pi \times 0,059^2} = 5,49 \text{ m/s}$$

So its Reynolds number is:

$$Re = \frac{1\,008 \times 5,49 \times 0,059}{1,8 \times 10^{-3}} = 181\,390$$

Since  $Re$  is larger than  $3\,000$ , the flow regime is turbulent, and the value of the friction factor can be determined from:

$$f = 0,079\,0 \times 181\,390^{-0,25} = 3,83 \times 10^{-3}$$

So the friction pressure gradient is given by:

$$\frac{\Delta p}{L} = \frac{2 \times 1\,008 \times 5,49^2 \times 3,83 \times 10^{-3}}{0,059} = 3,944 \text{ Pa/m}$$

which gives a friction pressure of:

$$\Delta p = 3\,944 \times 500 = 1\,997\,000 \text{ Pa}$$

### 13.2.2.2 EXAMPLE 2

What is the critical flow rate for turbulent flow, in cubic metres per second, for a Newtonian fluid with a density of  $1\,008 \text{ kg/m}^3$  and a viscosity of  $1,8 \times 10^{-3} \text{ Pa}\cdot\text{s}$  flowing in an annulus of diameter ratio  $0,2159/0,1778$ ? The critical velocity for turbulent flow is given by:

$$v_c = \frac{3\,000 \times 1,8 \times 10^{-3}}{1\,008 \times (0,2159 - 0,1778)} = 0,141 \text{ m/s}$$

This gives a critical flow rate of:

$$q_c = \frac{\pi \times (0,2159^2 - 0,1778^2)}{4} \times 0,141 = 1,66 \times 10^{-3} \text{ m}^3/\text{s}$$

What is the friction pressure, in pascals, over 500 m for the same fluid flowing at  $0,015 \text{ m}^3/\text{s}$ ? Its velocity is:

$$v = \frac{4 \times 0,015}{\pi(0,2159^2 - 0,1778^2)} = 1,27 \text{ m/s}$$

So its Reynolds number is:

$$Re = \frac{1\,008 \times 1,27 (0,2159 - 0,1778)}{1,8 \times 10^{-3}} = 27\,165$$

Since  $Re$  is larger than 3 000, the flow regime is turbulent, and the value of the friction factor can be determined from:

$$f = 0,079\,0 \times 27\,165^{-0,25} = 3,15 \times 10^{-3}$$

So the friction pressure gradient is given by:

$$\frac{\Delta p}{L} = \frac{2 \times 100\,8 \times 1,27^2 \times 6,15 \times 10^{-3}}{(0,2159 - 0,1778)} = 515 \text{ Pa/m}$$

which gives a friction pressure of:

$$\Delta p = 525 \times 500 = 262\,500 \text{ Pa}$$

## 13.3 Power Law fluids

### 13.3.1 Equations

For a Power Law fluid:

#### a) Reynolds number:

##### 1) Pipe flow

$$Re_{PL} = \frac{\rho v^{2-n} d_p^n}{8^{n-1} [(3n+1)/(4n)]^n k} \quad (67)$$

**2) Annular flow — Pipe**

$$Re_{PL} = \frac{\rho v^{2-n} (D_a - d_a)^n}{8^{n-1} [(3n+1)/(4n)]^n k} \quad (68)$$

**3) Annular flow — Slot**

$$Re_{PL} = \frac{\rho v^{2-n} (D_a - d_a)^n}{12^{n-1} [(2n+1)/(3n)]^n k} \quad (69)$$

where:

- $Re_{PL}$  is the Reynolds number for a Power Law fluid;
- $n$  is the Power Law index;
- $k$  is the consistency index, expressed in pascals per second to the power of  $n$  (Pa·s <sup>$n$</sup> );
- $\rho$  is the fluid density, expressed in kilograms per cubic metre;
- $v$  is the fluid mean velocity, expressed in metres per second;
- $d_p$  is the inner diameter of the pipe, expressed in metres;
- $d_a$  is the inner diameter of the annulus, expressed in metres;
- $D_a$  is the outer diameter of the annulus, expressed in metres.

**b) Fluid mean velocity**

Therefore the fluid mean velocity for a given value of the Reynolds number can be calculated from:

**1) Pipe flow**

$$v = \left( \frac{8^{n-1} [(3n+1)/(4n)]^n k Re_{PL}}{\rho d_p^n} \right)^{[1/(2-n)]} \quad (70)$$

**2) Annular flow — Pipe**

$$v = \left( \frac{8^{n-1} [(3n+1)/(4n)]^n k Re_{PL}}{\rho d_p^n} \right)^{[1/(2-n)]} \quad (71)$$

**3) Annular flow — Slot**

$$v = \left( \frac{12^{n-1} [(2n+1)/(3n)]^n k Re_{PL}}{\rho (D_a - d_a)^n} \right)^{[1/(2-n)]} \quad (72)$$

where

- $v$  is the fluid mean velocity, expressed in metres per second;
- $n$  is the Power Law index of a Power Law fluid;
- $k$  is the consistency index of a Power Law fluid, expressed in pascals per second to the power of  $n$  ( $\text{Pa}\cdot\text{s}^n$ );
- $Re_{\text{PL}}$  is the Reynolds number of a Power Law fluid;
- $\rho$  is the density, expressed in kilograms per cubic metre;
- $d_{\text{p}}$  is the inner diameter of the pipe, expressed in metres;
- $d_{\text{a}}$  is the inner diameter of the annulus, expressed in metres;
- $D_{\text{a}}$  is the outer diameter of the annulus, expressed in metres.

Depending on the value of the Reynolds number, the flow regime is classified as follows:

Flow regime	Pipe flow	Annular flow
Laminar	$Re_{\text{PL}} \leq Re_{\text{PL1}}$	$Re_{\text{PL}} \leq Re_{\text{PL1}}$
Transitional	$Re_{\text{PL1}} < Re_{\text{PL}} < Re_{\text{PL2}}$	$Re_{\text{PL1}} < Re_{\text{PL}} < Re_{\text{PL2}}$
Turbulent	$Re_{\text{PL}} \geq Re_{\text{PL2}}$	$Re_{\text{PL}} \geq Re_{\text{PL2}}$

with:

$$Re_{\text{PL1}} = 3\,250 - 1\,150 \times n \tag{73}$$

$$Re_{\text{PL2}} = 4\,150 - 1\,150 \times n \tag{74}$$

### c) Critical mean fluid velocity

The critical fluid mean velocity for turbulent flow,  $v_{\text{c}}$ , is given by:

#### 1) Pipe flow

$$v_{\text{c}} = \left( \frac{8^{n-1} [(3n+1)/(4n)]^n k Re_{\text{PL}}}{\rho d_{\text{p}}^n} \right)^{[1/(2-n)]} \tag{75}$$

#### 2) Annular flow — Pipe

$$v_{\text{c}} = \left( \frac{8^{n-1} [(3n+1)/(4n)]^n k Re_{\text{PL}}}{\rho (D_{\text{a}} - d_{\text{a}})^n} \right)^{[1/(2-n)]} \tag{76}$$

#### 3) Annular flow — Slot

$$v_{\text{c}} = \left( \frac{12^{n-1} [(2n+1)/(3n)]^n k Re_{\text{PL}}}{\rho (D_{\text{a}} - d_{\text{a}})^n} \right)^{[1/(2-n)]} \tag{77}$$

where

- $v_c$  is the critical fluid mean velocity, expressed in metres per second;
- $n$  is the Power Law index of a Power Law fluid;
- $k$  is the consistency index of a Power Law fluid, expressed in Pascals per second to the power of  $n$  ( $\text{Pa}\cdot\text{s}^n$ );
- $Re_{PL}$  is the Reynolds number of a Power Law fluid;
- $\rho$  is the density, expressed in kilograms per cubic metre;
- $d_p$  is the inner diameter of the pipe, expressed in metres;
- $d_a$  is the inner diameter of the annulus, expressed in metres;
- $D_a$  is the outer diameter of the annulus, expressed in metres.

**d) Friction factor, laminar flow**

In laminar flow, the friction factor,  $f$ , can be calculated from the following equations:

**1) Pipe flow and annular flow — Pipe**

$$f = \frac{16}{Re_{PL}} \quad (78)$$

**2) Annular flow — Slot**

$$f = \frac{24}{Re_{PL}} \quad (79)$$

where

- $f$  is the friction factor;
- $Re_{PL}$  is the Reynolds number of a Power Law fluid.

**e) Friction factor, turbulent flow**

In turbulent flow, whatever the flow geometry, the friction factor can be calculated from the following equation:

$$\frac{1}{\sqrt{f}} = \frac{4,0}{n^{0,75}} \times \log_{10} \left[ Re_{PL} f^{(1-n/2)} \right] - \frac{0,4}{n^{1,2}} \quad (80)$$

where

- $f$  is the friction factor;
- $Re_{PL}$  is the Reynolds number of a Power Law fluid.

In transitional flow, a log-log approximation is performed between  $Re = Re_{PL1}$  and  $Re = Re_{PL2}$ .

### 13.3.2 Example of calculations

#### 13.3.2.1 Example 1

What is the critical flow rate for turbulent flow, in metres per second, for a Power Law fluid with a density of  $1\,560\text{ kg/m}^3$ , a Power Law index of 0,5 and a consistency index of  $0,35\text{ Pa}\cdot\text{s}^n$  flowing in a pipe of inner diameter  $d\ 0,059\text{ m}$ ? The critical velocity for turbulent flow is given by:

$$v_c = \left[ \frac{8^{-0,5} \times (2,5/2,0)^{0,5} \times 0,35 \times 3\,575}{1\,560 \times 0,059^{0,5}} \right]^{[1/(2-0,5)]} = 1,29\text{ m/s}$$

This gives a critical flow rate of:

$$q_c = \frac{\pi \times 0,059^2}{4} \times 1,29 = 3,52 \times 10^{-3}\text{ m}^3/\text{s}$$

What is the friction pressure, in pascals, over 500 m for the same fluid flowing at  $0,015\text{ m}^3/\text{s}$ ? Its velocity is:

$$v = \frac{4 \times 0,015}{\pi \times 0,059^2} = 5,49\text{ m/s}$$

So its Reynolds number is:

$$Re = \frac{1\,560 \times 5,49^{1,5} \times 0,059^{0,5}}{8^{-0,5} \times (2,5/2,0)^{0,5} \times 0,35} = 35\,230$$

Since  $Re$  is larger than 3 575, the flow regime is turbulent and the value of the friction factor can be determined from:

$$f = 0,0\,730 \times 35\,230^{-0,293} = 3,40 \times 10^{-3}$$

So the friction pressure gradient is given by:

$$\frac{\Delta p}{L} = \frac{2 \times 1\,560 \times 5,48^2 \times 3,40 \times 10^{-3}}{0,059} = 5\,420\text{ Pa/m}$$

which gives a friction pressure of:

$$\Delta p = 5\,420 \times 500 = 2\,710\,000\text{ Pa}$$

#### 13.3.2.2 Example 2

What is the critical flow rate for turbulent flow, in cubic metres per second, for a Power Law fluid with a density of  $1\,560\text{ kg/m}^3$ , a Power Law index of 0,5 and a consistency index of  $0,35\text{ Pa}\cdot\text{s}^n$  flowing in an annulus of diameter ratio  $0,2159\text{ m}/0,1778\text{ m}$ ? The critical velocity for turbulent flow is given by:

$$v_c = \left[ \frac{8^{-0,5} \times (2,5/2,0)^{0,5} \times 0,35 \times 3\,575}{1\,560 \times (0,2159 - 0,1778)^{0,5}} \right]^{[1/(2-0,5)]} = 1,38\text{ m/s}$$

for the pipe approximation, and:

$$v_c = \left[ \frac{12^{-0,5} \times (2,0/1,5)^{0,5} \times 0,35 \times 3\,575}{1\,560 \times (0,215\,9 - 0,177\,8)^{0,5}} \right]^{[1/(2-0,5)]} = 1,23 \text{ m/s}$$

for the slot approximation. This gives a critical flow rate of:

$$q_c = \frac{\pi \times (0,215\,9^2 - 0,177\,8^2)}{4} \times 1,38 = 16,26 \times 10^{-3} \text{ m}^3/\text{s}$$

for the pipe approximation and:

$$q_c = \frac{\pi \times (0,215\,9^2 - 0,177\,8^2)}{4} \times 1,23 = 14,50 \times 10^{-3} \text{ m}^3/\text{s}$$

for the slot approximation.

What is the friction pressure, in pascals, over 500 m for the same fluid flowing at 0,024 m<sup>3</sup>/s? Its velocity is:

$$v = \frac{4 \times 0,024 \times 1}{\pi \times (0,215\,9^2 - 0,177\,8^2)} = 2,04 \text{ m/s}$$

So its Reynolds number is:

$$Re = \frac{1\,560 \times 2,04^{1,5} \times (0,215\,9 - 0,177\,8)^{0,5}}{8^{-0,5} \times (2,5/2,0)^{0,5} \times 0,35} = 6\,414$$

for the pipe approximation, and:

$$Re = \frac{1\,560 \times 2,04^{1,5} \times (0,215\,9 - 0,177\,8)^{0,5}}{12^{-0,5} \times (2,0/1,5)^{0,5} \times 0,35} = 7\,855$$

for the slot approximation. Since *Re* is larger than 3 575, the flow regime is turbulent and the value of the friction factor can be determined from:

$$f = 0,073\,0 \times 6\,414^{-0,293} = 5,95 \times 10^{-3}$$

for the pipe approximation, and:

$$f = 0,073\,0 \times 7\,855^{-0,293} = 5,27 \times 10^{-3}$$

for the slot approximation. So the friction pressure gradient is given by:

$$\frac{\Delta p}{L} = \frac{2 \times 1\,560 \times 2,04^2 \times 5,595 \times 10^{-3}}{(0,215\,9 - 0,177\,8)} = 1892 \text{ Pa/m}$$

which gives a friction pressure of:

$$\Delta p = 1892 \times 500 = 1\,033\,000 \text{ Pa}$$



for the pipe approximation, and:

$$\Delta p = 1783 \times 500 = 891\,500 \text{ Pa}$$

for the slot approximation.

## 13.4 Bingham Plastic fluids

### 13.4.1 Equations

A Bingham Plastic fluid is characterized by its plastic viscosity  $\mu_p$  and yield point  $\tau_0$ . In the equations that follow, the plastic viscosity and yield point obtained from rotational viscometer data,  $\mu_{p,RV}$  and  $\tau_{0,RV}$ , are modified as follows.

$$\mu_p = K_{\mu p} \exp \left[ 0,9\,815 \ln(\mu_{p,RV} K_{\mu p,RV}) - 0,03\,832 \right] \quad (81)$$

$$\tau_0 = K_{\tau_0} (1,193 \tau_{0,RV} K_{\tau_0,RV} - 1,611) \quad (82)$$

where

$\mu_p$  is the plastic viscosity of a Bingham Plastic fluid, expressed in pascal seconds (Pa·s);

$K_{\mu p}$  is 0,001;

$\mu_{p,RV}$  is the plastic viscosity obtained from rotational viscometer, expressed in pascal seconds (Pa·s);

$K_{\mu p,RV}$  is 1 000;

$\tau_0$  is the yield stress of a Bingham Plastic fluid, expressed in pascals;

$K_{\tau_0}$  is 0,478 8;

$\tau_{0,RV}$  is the yield point obtained from rotational viscometer, expressed in pascals;

$K_{\tau_0,RV}$  is 2,088 5.

#### a) Bingham Reynolds number

For a Bingham Plastic fluid, with a plastic viscosity  $\mu_p$ , a yield point  $\tau_0$  and a density  $\rho$ , the Bingham Reynolds number,  $Re_{BP}$ , is defined as:

##### 1) Pipe flow

$$Re_{BP} = \frac{V \rho d_p}{\mu_p} \quad (83)$$

##### 2) Annular flow — Pipe

$$Re_{BP} = \frac{v \rho (D_a - d_a)}{\mu_p} \quad (84)$$

##### 3) Annular flow — Slot

$$Re_{BP} = \frac{v \rho (D_a - d_a)}{1,5 \times \mu_p} \quad (85)$$

where:

$Re_{BP}$  is the Reynolds number of a Bingham Plastic fluid;

$v$  is the fluid mean velocity, expressed in metres per second;

$\rho$  is the density, expressed in kilograms per cubic metre;

$d_p$  is the inner diameter of the pipe, expressed in metres;

$d_a$  is the inner diameter of the annulus, expressed in metres;

$D_a$  is the outer diameter of the annulus, expressed in metres;

$\mu_p$  is the plastic viscosity of a Bingham plastic fluid, expressed in pascal seconds (Pa·s).

**b) Fluid mean velocity**

Therefore the fluid mean velocity for a given value of the Reynolds number can be calculated from:

**1) Pipe flow**

$$v = \frac{\mu_p Re_{BP}}{\rho d_p} \quad (86)$$

**2) Annular flow — Pipe**

$$v = \frac{\mu_p Re_{BP}}{\rho(D_a - d_a)} \quad (87)$$

**3) Annular flow — Slot**

$$v = \frac{1,5\mu_p Re_{BP}}{\rho(D_a - d_a)} \quad (88)$$

where

$v$  is the fluid mean velocity, expressed in metres per second;

$\mu_p$  is the plastic viscosity of a Bingham Plastic fluid, expressed in pascal seconds (Pa·s);

$Re_{BP}$  is the Reynolds number of a Bingham Plastic fluid;

$\rho$  is the density, expressed in kilograms per cubic metre;

$d_p$  is the inner diameter of the pipe, expressed in metres;

$d_a$  is the inner diameter of the annulus, expressed in metres;

$D_a$  is the outer diameter of the annulus, expressed in metres.

Depending on the value of the Reynolds number, the flow regime is classified as follows:

Flow regime	Pipe flow	Annular flow
Laminar	$Re_{BP} \leq Re_{BP1}$	$Re_{BP} \leq Re_{BP1}$
Transitional	$Re_{BP1} > Re_{BP} < Re_{BP2}$	$Re_{BP1} > Re_{BP} < Re_{BP2}$
Turbulent	$Re_{BP} \geq Re_{BP2}$	$Re_{BP} \geq Re_{BP2}$

c)  $Re_{BP1}$  and  $Re_{BP2}$  are estimated as follows

1) Pipe flow and annular flow — Pipe

$$Re_{BP1} = Re_{BP2} - 866(1 - \alpha_c) \quad (89)$$

2) Annular flow — Slot

$$Re_{BP1} = Re_{BP2} - 577(1 - \alpha_c) \quad (90)$$

d)  $Re_{BP2}$  is calculated as shown below

1) Pipe flow and annular flow — Pipe

$$Re_{BP2} = \frac{He(0,968\,774 - 1,362\,439 \times \alpha_c + 0,160\,082\,2 \times \alpha_c)}{8\alpha_c} \quad (91)$$

2) Annular flow — Slot

$$Re_{BP2} = \frac{He(0,968\,774 - 1,362\,439 \times \alpha_c + 0,160\,082\,2 \times \alpha_c)}{12\alpha_c} \quad (92)$$

where

$He$  is the Hedstrom number [see e) below];

and  $\alpha_c$  is calculated from:

$$\alpha_c = \frac{3 \left( \frac{2He}{24\,500} + \frac{3}{4} \right) - \sqrt{\left( \frac{2He}{24\,500} + \frac{3}{4} \right)^2 - 4 \left( \frac{He}{24\,500} \right)^2}}{2 \left( \frac{He}{24\,500} \right)} \quad (93)$$

e) Hedstrom number

$He$  is the Hedstrom number and is calculated from:

1) Pipe flow

$$He = \frac{\tau_o \rho d_p^2}{\mu_p^2} \quad (94)$$

2) **Annular flow — Pipe**

$$He = \frac{\tau_0 \rho (D_a - d_a)^2}{\mu_p^2} \quad (95)$$

3) **Annular flow — Slot**

$$He = \frac{\tau_0 \rho (D_a - d_a)^2}{1,5^2 \mu_p^2} \quad (96)$$

where

$He$  is the Hedstrom number;

$\tau_0$  is the yield stress of a Bingham Plastic fluid, expressed in pascals;

$\rho$  is the density, expressed in kilograms per cubic metre;

$d_p$  is the inner diameter of the pipe, expressed in metres;

$d_a$  is the inner diameter of the annulus, expressed in metres;

$D_a$  is the outer diameter of the annulus, expressed in metres.

$\mu_p$  is the plastic viscosity of a Bingham Plastic fluid, expressed in pascal seconds.

f) **Critical fluid mean velocity**

The critical fluid mean velocity for turbulent flow,  $v_c$ , is given by:

1) **Pipe flow**

$$v_c = \frac{\mu_p Re_{BP2}}{\rho d_p} \quad (97)$$

2) **Annular flow — Pipe**

$$v_c = \frac{\mu_p Re_{BP2}}{\rho (D_a - d_a)} \quad (98)$$

3) **Annular flow — Slot**

$$v_c = \frac{1,5 \mu_p Re_{BP2}}{\rho (D_a - d_a)} \quad (99)$$

where

$v_c$  is the critical fluid mean velocity, expressed in metres per second;

$\mu_p$  is the plastic viscosity of a Bingham Plastic fluid, expressed in pascal seconds;

$Re_{BP2}$  is the Reynolds number of a Bingham Plastic fluid;

$\rho$  is the density, expressed in kilograms per cubic metres;

- $d_p$  is the inner diameter of the pipe, expressed in metres;
- $d_a$  is the inner diameter of the annulus, expressed in metres;
- $D_a$  is the outer diameter of the annulus, expressed in metres.

**g) Friction factor, laminar flow**

In laminar flow the friction factor,  $f$ , can be calculated from the following equations:

**1) Pipe flow and annular flow — Pipe**

$$f = 16 \left( \frac{1}{Re_{BP}} + \frac{He}{6Re_{BP}^2} \right) \quad (100)$$

**2) Annular flow — Slot**

$$f = 16 \left( \frac{1}{Re_{BP}} + \frac{(9/8)He}{6Re_{BP}^2} \right) \quad (101)$$

where

- $f$  is the friction factor;
- $Re_{BP}$  is the Reynolds number of a Bingham Plastic fluid;
- $He$  is the Hedstrom number.

From fluid mechanics, the exact analytically derived friction factor correlation for a Bingham Plastic fluid flowing through a *pipe* is:

$$f = 16 \left( \frac{1}{Re_{BP}} + \frac{He}{6Re_{BP}^2} - \frac{He^4}{3f^3 Re_{BP}^8} \right) \quad (102)$$

Equation (100) is obtained from Equation (102) when the ratio  $(\tau_o/\tau_w)^4$  can be neglected, where  $\tau_o$  is the yield stress of the fluid and  $\tau_w$  is the shear stress at the wall.

From fluid mechanics, the exact analytically derived friction factor correlation for a Bingham Plastic fluid flowing through a *slot* is:

$$f = 24 \left( \frac{1}{Re_{BP,h}} + \frac{He_h}{8Re_{BP,h}^2} - \frac{He_h^3}{6f^2 Re_{BP,h}^6} \right) \quad (103)$$

If the ratio  $(\tau_o/\tau_w)^4$  can be neglected, where  $\tau_o$  is the yield stress of the fluid and  $\tau_w$  is the shear stress at the wall, then Equation (103), friction factor correlation for a Bingham Plastic fluid flowing through a slot, can be written as:

$$f = 24 \left( \frac{1}{Re_{BP,h}} + \frac{He_h}{8Re_{BP,h}^2} \right) \quad (104)$$

where the  $Re_{BP,h}$  and  $He_h$  for slot flow are defined as:

$$Re_{BP,h} = \frac{v\rho(D_h - D_o)}{\mu_p} \quad (105)$$

and

$$He_h = \frac{\tau_o\rho(D_h - D_o)^2}{\mu_p^2} \quad (106)$$

where

$Re_{BP}$  is the Reynolds number of a Bingham Plastic fluid;

$v$  is the fluid mean velocity, expressed in metres per second;

$\rho$  is the density, expressed in kilograms per cubic metres;

$d_a$  is the inner diameter of the annulus, expressed in metres;

$D_a$  is the outer diameter of the annulus, expressed in metres.

$\mu_p$  is the plastic viscosity of a Bingham Plastic fluid, expressed in pascal seconds;

$He$  is the Hedstrom number;

$\tau_o$  is the yield stress of a Bingham Plastic fluid, expressed in pascals.

In Equation (101), friction factor of a Bingham Plastic fluid flowing through a slot, if the Reynolds and Hedstrom numbers are expressed in terms of hydraulic diameters, then the equation can be written as:

$$f = 16 \left( \frac{1,5}{Re_{BP,h}} + \frac{(9/8)He_h}{6Re_{BP,h}^2} \right) \quad (107)$$

which can be simplified to

$$f = 24 \left( \frac{1}{Re_{BP,h}} + \frac{He_h}{8Re_{BP,h}^2} \right) \quad (108)$$

which is the same as Equation (104).

Hence Equations (100) to (103) recommended here for laminar flow of a Bingham Plastic fluid can be obtained from analytically derived exact equations.

In turbulent flow, whatever the flow geometry is, the friction factor can be calculated from the following equation:

$$f = A(Re_{BP})^{-B} \quad (109)$$

where

$f$  is the friction factor;

$Re_{BP}$  is the Reynolds number of a Bingham Plastic fluid.

The constants A and B are given below.

<i>He</i>	<i>A</i>	<i>B</i>
$\leq 0,75 \times 10^5$	0,20 656	0,3 780
$0,75 \times 10^5 < He \leq 1,575 \times 10^5$	0,26 365	0,38 931
$> 1,575 \times 10^5$	0,20 521	0,35 579

In transitional flow, a log-log approximation is performed between  $Re = Re_{BP1}$  and  $Re = Re_{BP2}$ .

### 13.4.2 Examples of calculations

#### 13.4.2.1 Example 1

What is the critical flow rate for turbulent flow, in metres per second, for a Bingham Plastic fluid with a density of  $1\,560\text{ kg/m}^3$ , rotational viscometer plastic viscosity  $\mu_p$  of  $6 \times 10^{-3}\text{ Pa}\cdot\text{s}$  and rotational viscometer yield point  $\tau_0$  of  $4\text{ Pa}$ , flowing in a pipe having inner diameter  $d$  of  $0,059\text{ m}$ ?

The rotational viscometer's PV and YP are modified as:

$$\mu_p = 1 \times 0,001 \times \exp\left[0,9\,815 \ln(6 \times 10^{-3} \times 1000) - 0,03\,832\right] = 5,586 \times 10^{-3}$$

$$\tau_p = 0,4\,788 \times (1,1938 \times 4 \times 2,0\,885 - 1,611) = 4,004$$

The Hedstrom number *He* is:

$$He = \frac{4,004 \times 1\,560 \times 0,059^2}{(5,5\,862 \times 10^{-3})^2} = 696\,596$$

Once *He* is calculated,  $\alpha_c$  and  $Re_{BP2}$  are estimated as:

$$\alpha_c = \frac{3 \left[ \frac{(2 \times 696\,596)/24\,500 + 3/4}{2(696\,596/24\,500)} - \sqrt{\left[ \frac{(2 \times 696\,596)/24\,500 + 3/4}{2(696\,596/24\,500)} \right]^2 - 4(696\,596/24\,500)^2} \right]}{4} = 0,638$$

$$Re_{BP2} = \frac{696\,596 \times \left[ 0,968\,774 - (1,362\,439 \times 0,638) + (0,160\,082\,2 \times 0,638^4) \right]}{8 \times 0,638} = 17\,203$$

The critical velocity is:

$$v_c = \frac{5,586 \times 10^{-3} \times 17\,203}{1\,560 \times 0,059} = 1,04\text{ m/s}$$

and the critical flowrate is:

$$q_c = \frac{\pi \times 0,059}{4} \times 1,04 = 2,85 \times 10^{-3}\text{ m}^3/\text{s}$$

**13.4.2.2 Example 2**

What is the friction pressure, in pascals, over 500 m for the same fluid flowing at  $0,015 \text{ m}^3\cdot\text{s}^{-1}$ ?

Its velocity is:

$$v = \frac{4 \times 0,015 \times 1}{\pi \times 0,059} = 5,50 \text{ m/s}$$

So the Bingham Reynolds number is:

$$Re_{BP} = \frac{1 \times 5,50 \times 1560 \times 0,059}{5,586 2 \times 10^{-3}} = 90 620$$

Since  $Re$  is greater than  $Re_{BP2}$  (17 203) the flow regime is turbulent, and since  $He$  is greater than  $1,525 \times 10^5$  the value of the friction factor is determined from:

$$f = 0,206 56 \times 90 620^{-0,378 0} = 2,76 \times 10^{-3}$$

So the friction pressure gradient is given by:

$$\frac{\Delta p}{L} = \frac{2 \times 1560 \times 5,5 \times (2,76 \times 10^{-3}) \times 1}{0,059} = 803 \text{ Pa/m}$$

which gives a friction pressure of:

$$\Delta p = 803 \times 500 = 401 500 \text{ Pa}$$

**13.4.2.3 Example 3**

What is the critical flow rate for turbulent flow, in cubic metres per second, for a Bingham Plastic fluid with a density of  $1 560 \text{ kg/m}^3$ , a rotational viscometer plastic viscosity of  $6 \times 10^{-3} \text{ Pa}\cdot\text{s}$  and a rotational viscometer yield point of 4 Pa, flowing in a  $0,215 9/0,177 8 \text{ m}$  annulus?

The ratio is  $d_a/D_a = 0,177 8/0,215 9 = 0,823 5$

This is greater than 0,3, hence slot approximation shall be used. However, the example will be worked out for both pipe and slot models.

The critical velocity for turbulent flow is estimated as follows:

**a) Hedstrom number — Annular flow — Pipe**

$$He = \frac{4,004 \times 1560 \times (0,215 9 - 0,177 8)^2}{(5,586 \times 10^{-3})^2} = 290 580$$

**b) Hedstrom number — Annular flow — Slot**

$$He = \frac{4,004 \times 1560 \times (0,215 9 - 0,177 8)^2}{1,5^2 \times (5,586 2 \times 10^{-3})^2} = 129 150$$



c)  $\alpha_c$  — Annular flow — Pipe

$$\alpha_c = \frac{3 \left[ \frac{(2 \times 290\,580)}{24\,500} + \frac{3}{4} \right] - \sqrt{\left[ \frac{(2 \times 290\,580)}{24\,500} + \frac{3}{4} \right]^2 - 4 \left( \frac{290\,580}{24\,500} \right)^2}}{2 \left( \frac{290\,580}{24\,500} \right)} = 0,583\,6$$

d)  $\alpha_c$  — Annular flow — Slot

$$\alpha_c = \frac{3 \left[ \frac{(2 \times 129\,150)}{24\,500} + \frac{3}{4} \right] - \sqrt{\left[ \frac{(2 \times 129\,150)}{24\,500} + \frac{3}{4} \right]^2 - 4 \left( \frac{129\,150}{24\,500} \right)^2}}{2 \left( \frac{129\,150}{24\,500} \right)} = 0,515\,4$$

e) Critical Bingham Reynolds number  $Re_{BP2}$  — Annular flow — Pipe

$$Re_{BP2} = \frac{290\,580 \times \left[ 0,968\,774 - 1,362\,439 \times 0,583\,6 + 0,160\,082\,2 \times (0,583\,6)^4 \right]}{8 \times 0,583\,6} = 11\,964$$

f) Critical Bingham Reynolds number  $Re_{BP2}$  — Annular flow — Slot

$$Re_{BP2} = \frac{129\,150 \times \left[ 0,968\,774 - 1,362\,439 \times 0,515\,4 + 0,160\,082\,2 \times (0,515\,4)^4 \right]}{12 \times 0,510\,2} = 7\,040$$

## g) Critical fluid mean velocity for turbulent flow — Annular flow — Pipe

$$v_c = \frac{(5,586 \times 10^{-3}) \times 11\,964}{1560 \times (0,215\,9 - 0,177\,8)} = 1,12 \text{ m/s}$$

## h) Critical fluid mean velocity for turbulent flow — Annular flow — Slot

$$v_c = \frac{1,5 \times (5,586 \times 10^{-3}) \times 7\,040}{1560 \times (0,215\,9 - 0,177\,8)} = 0,99 \text{ m/s}$$

## i) Critical flowrate — Annular flow — Pipe

$$q_c = \frac{\pi \times (0,215\,9^2 - 0,177\,8^2) \times 1,12}{4} = 0,013 \text{ m}^3/\text{s}$$

## j) Critical flowrate — Annular flow — Slot

$$q_c = \frac{\pi \times (0,215\,9^2 - 0,177\,8^2) \times 1,12}{4} = 0,013 \text{ m}^3/\text{s}$$

## 13.4.2.4 Example 4

What is the friction pressure, in pascals, over 500 m for the same fluid flowing at 0,015 m<sup>3</sup>/s?

Its velocity is:

$$v = \frac{4 \times 0,15}{\pi(0,2159^2 - 0,1778^2)} = 1,27 \text{ m/s}$$

**a) Reynolds number — Annular flow — Pipe**

$$Re_{BP} = \frac{1,27 \times 1560 \times (0,2159 - 0,1778)}{5,5862 \times 10^{-3}} = 13\,520$$

**b) Reynolds number — Annular flow — Slot**

$$Re_{BP} = \frac{1,27 \times 1560 \times (0,2159 - 0,1778)}{1,5 \times 5,5862 \times 10^{-3}} = 9\,008$$

Since  $Re_{BP}$  is greater than  $Re_{BP2}$  in both pipe and slot models, the flow regime is turbulent.

**c) Pipe-flow model**

For the pipe-flow model, the Hedstrom number,  $He$ , is greater than  $1,575 \times 10^5$ . So the friction factor,  $f$ , is given by:

$$f = 0,20521 \times 13\,520^{-0,35579} = 6,96 \times 10^{-3}$$

Thus the friction pressure gradient is given by:

$$\frac{\Delta p}{L} = \frac{2 \times 1560 \times 1,27^2 \times (6,96 \times 10^{-3}) \times 1}{(0,2159 - 0,1778)} = 919,28 \text{ Pa/m}$$

which gives a friction pressure of:

$$\Delta p = 919,28 \times 500 = 459\,640 \text{ Pa}$$

Slot-flow model

For the slot-flow model, the Hedstrom number,  $He$ , is such that  $0,75 \times 10^5 < He < 1,575 \times 10^5$ . So the friction factor,  $f$ , is given by:

$$f = 0,263651 \times 9\,008^{-0,38931} = 7,61 \times 10^{-3}$$

So the friction pressure gradient is given by:

$$\frac{\Delta p}{L} = \frac{2 \times 1560 \times 1,27^2 \times (7,61 \times 10^{-3}) \times 1}{(0,2159 - 0,1778)} = 1005 \text{ Pa/m}$$

which gives a friction pressure of:

$$\Delta p = 1005 \times 500 = 502\,500 \text{ Pa}$$

### 13.5 Conversion factors

SI unit	to be multiplied by	to get value in USC units
Pa	$1 \times 10^{-5}$	bar
m <sup>3</sup>	6,29	bbl
m <sup>3</sup> /s	$6,29 \times 60$	bbl/min
Pa·s	1 000	cP
m	3,28	ft
m <sup>3</sup> /s	$264,19 \times 60$	gal/min
m	39,37	in
m <sup>3</sup>	1 000	l
m <sup>3</sup> /s	$1\,000 \times 60$	l/min
kg/m <sup>3</sup>	$2,2 \times (3,785\,2 \times 10^3)$	lbm/gal
kg/m <sup>3</sup>	$2,2 \times 0,304\,8^3$	lbm/ft <sup>3</sup>
Pa	2,09	lbf/100 ft <sup>2</sup>
Pa·s <sup>n</sup>	0,020 9	lbf·s <sup>n</sup> /ft <sup>2</sup>
Pa	6 894,65	psi

## 14 Test procedure for arctic cementing slurries

### 14.1 General

This procedure is intended for the testing of cement slurries that are to be placed in areas known to contain permafrost. The conditioning temperature for the test equipment, materials to be tested and the test temperatures shall be controlled to  $\pm 1\text{ °C}$  ( $\pm 2\text{ °F}$ ).

### 14.2 Preparation of cement slurry

Test samples shall be prepared according to Clause 5, except that the cement blend and mixing equipment shall be preconditioned at  $-7\text{ °C}$  ( $20\text{ °F}$ ). Mix water shall be pre-chilled to  $1\text{ °C}$  ( $34\text{ °F}$ ), and the slurry temperature shall be recorded immediately after mixing;  $\sim 4\text{ °C}$  ( $40\text{ °F}$ ) is typical. Each of the above temperatures shall be measured and reported on all tests.

### 14.3 Fluid fraction

The fluid fraction shall be expressed as percent by mass of basic dry blend (not including any additives needed for placement).

### 14.4 Thickening time

A thickening-time test shall be performed in a consistometer at  $4\text{ °C}$  ( $40\text{ °F}$ ) at atmospheric pressure.

### 14.5 Compressive strength

Specimens shall be cured at  $-7\text{ °C}$  ( $20\text{ °F}$ ) and  $4\text{ °C}$  ( $40\text{ °F}$ ) for the desired testing period, i.e. 1 d, 3 d or 7 d.

The moulds shall be preconditioned by cooling to the temperature of the curing bath, i.e.  $-7\text{ °C}$  ( $20\text{ °F}$ ) or  $4\text{ °C}$  ( $40\text{ °F}$ ).

Stir the selected cementing compositions for 90 min in a consistometer at 4 °C (40 °F) before pouring into the preconditioned moulds for curing. For curing at temperatures below 0 °C (32 °F), seal the test specimens in a container of fresh water at test temperature or 2 °C (35 °F), whichever is higher. Submerge the sealed container in a mineral oil or glycol bath at test temperature in a manner consistent with avoiding contamination of the fresh water and specimens.

EXAMPLE For 24-h compressive strengths:

- a) Stir cement slurry for 90 minutes at 4 °C (40 °F) and atmospheric pressure.
- b) Quickly pour slurry into preconditioned moulds, seal in a suitable container filled with fresh water [for tests below 0 °C (32 °F)], and submerge in curing bath.
- c) Cure slurry for 22 h at -7 °C (20 °F) or 4 °C (40 °F), and monitor temperature.
- d) Remove cubes from moulds 30 min before the test and place them in 4 °C (40 °F) water. Crush the specimens at the loading rates described in 7.5.6 a).

#### **14.6 Freeze-thaw cycling at atmospheric pressure**

Prepare slurry as in 14.2 (do not precondition the slurry as in 14.5) and cure under the following sequence (it is suggested that the cycle begin on a Monday):

- a) 48 h at 4 °C (40 °F) Monday
- b) 24 h at -7 °C (20 °F) Wednesday
- c) 24 h at 4 °C (40 °F) Thursday
- d) 72 h at 38 °C (100 °F) Friday
- e) 72 h at 77 °C (170 °F) Monday
- f) 24 h at 38 °C (100 °F) Thursday
- g) 72 h at -7 °C (20 °F) Friday
- h) Raise to 4 °C (40 °F) and repeat cycle on Monday.

#### **14.7 Compressive strength cyclic testing**

Examine the cement cubes and break them after 1 and 3 cycles under these conditions (14 d and 42 d). Cure all compressive-strength test cubes under water and in moulds during cycles with top of cement column exposed to water. Break control specimens after 48 h at 4 °C (40 °F) for reference.

### **15 Well-simulation slurry stability tests**

#### **15.1 Introduction**

The purpose of this test is to determine the static (quiescent) stability of a cement slurry. The cement slurry is conditioned to simulate dynamic placement in a wellbore. The slurry is then left static to determine if free fluid separates from the slurry or to determine if the cement slurry experiences particle sedimentation. Both the free fluid result and the sedimentation result are required in order to understand the static stability of the slurry under downhole conditions. Free fluid can be formed with minimal sedimentation, and sedimentation can take place without free fluid being formed. Therefore, both results must be evaluated to determine slurry stability. Excessive free fluid and settling are normally considered detrimental to cement sheath quality. The amount of free fluid or settling that is acceptable varies with the application.

## 15.2 Slurry mixing

Prepare the cement slurry according to Clause 5. If performing the sedimentation test described in 15.6, immediately after mixing the slurry, measure the density of the slurry using a pressurized fluid density balance.

## 15.3 Slurry conditioning

Any consistometer referenced in Clause 9 may be used. The following procedure applies to the most commonly used equipment.

Place the slurry in the container of the pressurized consistometer and begin a thickening-time test in accordance with Clause 9. Apply pressure and heat or cool according to the thickening-time schedule which most closely simulates actual field conditions. If desired, the slurry may be held at the specified temperature and pressure for  $30 \text{ min} \pm 30 \text{ s}$  or other desired conditioning period before proceeding to the next step. If the conditioning temperature is greater than  $88 \text{ }^\circ\text{C}$  ( $190 \text{ }^\circ\text{F}$ ), cool the slurry to approximately  $88 \text{ }^\circ\text{C}$  ( $190 \text{ }^\circ\text{F}$ ) for safety. If the boiling point of water in your area is less than  $100 \text{ }^\circ\text{C}$  ( $212 \text{ }^\circ\text{F}$ ), adjust test temperatures accordingly.

Release the pressure slowly [about  $1\,380 \text{ kPa/s}$  ( $200 \text{ psi/s}$ )]. Remove the slurry container from the consistometer, keeping the container upright so oil does not mix with the slurry. Remove the top locking ring, drive bar and collar from the shaft and the diaphragm cover. Syringe and blot any oil from the top of the diaphragm. Remove the diaphragm and the support ring. Syringe and blot any remaining oil from the top of the slurry. If the contamination is severe, discard the slurry and begin the test again. Remove the paddle and stir the slurry briskly with a spatula to ensure a uniform slurry.

At this point, proceed with either 15.4 or 15.5 for a free-fluid test. For a sedimentation test, proceed to 15.6.

NOTE The  $88 \text{ }^\circ\text{C}$  ( $190 \text{ }^\circ\text{F}$ ) safety temperature assumes a boiling point for water of  $100 \text{ }^\circ\text{C}$  ( $212 \text{ }^\circ\text{F}$ ).

## 15.4 Free-fluid test with heated static period

### 15.4.1 General

Pour the slurry into a clear graduated tube. The ratio of the slurry-filled length to the inside tube diameter shall be greater than 6:1 and less than 8:1. The clear tube shall be inert to well cements and shall not deform during the test. The clear tube shall be graduated such that the slurry volume placed in the tube can be visually determined with a precision of  $\pm 2 \text{ ml}$ . The free-fluid test slurry volume shall be between 100 ml and 250 ml, inclusive. Document the slurry volume placed in the tube when the tube is vertical. Document the tube dimensions as well.

Preheat (or precool) a test chamber for curing the slurry during the static period to  $T_{\text{BHC}}$  or  $88 \text{ }^\circ\text{C}$  ( $190 \text{ }^\circ\text{F}$ ), whichever is cooler. To minimize the effects of condensation on the test results, a test temperature of  $88 \text{ }^\circ\text{C}$  ( $190 \text{ }^\circ\text{F}$ ) was chosen, and a boiling point for water of  $100 \text{ }^\circ\text{C}$  ( $212 \text{ }^\circ\text{F}$ ) assumed. If the boiling point of water in your area is less than  $100 \text{ }^\circ\text{C}$  ( $212 \text{ }^\circ\text{F}$ ), adjust the  $88 \text{ }^\circ\text{C}$  ( $190 \text{ }^\circ\text{F}$ ) test temperature accordingly. This chamber may be an atmospheric heating or cooling bath/oven/jacket/chamber, or a suitable pressurized heating/cooling chamber that uses hydrocarbon oil to transmit heating/cooling to the slurry.

A bath/oven/jacket/chamber or pressurized chamber is designated hereafter in this clause as a chamber. When hydrocarbon oil is used, the oil shall have a flash point that satisfactorily meets the safety requirements of the organization performing the test.

### 15.4.2 Free-fluid tests at temperatures less than $88 \text{ }^\circ\text{C}$ ( $190 \text{ }^\circ\text{F}$ )

Immediately place the graduated tube in a heating or cooling chamber that is preheated or precooled to  $T_{\text{BHC}}$ . Cover the opening of the graduated tube to prevent evaporation. The chamber must be able to heat or cool the entire slurry. The tube can be tilted to simulate hole angle, if desired. Appropriate precautions shall be taken to ensure the static curing is performed at essentially vibration free conditions.

The temperature is maintained at  $T_{\text{BHC}}$  for the remainder of the test. The test duration is 2 h, starting from the time the slurry is poured into the clear tube. After the 2 h test period, the volume of free fluid (clear or coloured fluid on top of the cement slurry inside of the clear tube) shall be measured, with a precision of  $\pm 0,2$  ml.

The volume fraction,  $\varphi$ , of free fluid, expressed as a percent, is then calculated.

$$\varphi = \frac{V_{\text{F}}(100)}{V_{\text{S}}} \quad (110)$$

where

$V_{\text{F}}$  is the volume, in millilitres, of free fluid;

$V_{\text{S}}$  is the volume in millilitres, of slurry.

#### 15.4.3 Free-fluid test at temperatures greater than or equal to 88 °C (190 °F)

Place the graduated tube in a preheated 88 °C (190 °F) oil-filled heating chamber. Optionally, tilt the tube to simulate hole angle. Further heat the slurry to  $T_{\text{BHC}}$  in the time required to take the slurry from a depth with 88 °C (190 °F) circulating temperature to  $T_{\text{BHC}}$ . Some heating chambers may not be able to heat fast enough; in that case heat as fast as possible but minimize overshooting the  $T_{\text{BHC}}$ . Maintain the slurry at  $T_{\text{BHC}}$  until it is time to start cooling the chamber back down to 88 °C (190 °F). The time required to cool various pieces of equipment from elevated temperatures back to 88 °C (190 °F) will vary. Maintain the pressure on the curing chamber high enough throughout the test so the slurry cannot boil (Table 4). The pressure applied can simulate bottom-hole conditions, if desired. Avoid constant pump cycling, in order to prevent vibration. The schedules found in Clause 9 can be used to aid in selecting pressure- and temperature-change rates. Take appropriate precautions to ensure that the static curing is performed in essentially vibration-free conditions.

The 2 h test period is initiated when the conditioned slurry is poured into the graduated tube. Slurries need to be cooled to 88 °C (190 °F) before the free fluid can be measured. This cooling time is part of the 2 h test period. After the 2 h test period, the volume of free fluid (clear or coloured fluid on top of the cement slurry inside of the clear tube) shall be measured. Free fluid for slurries immersed in hydrocarbon oil collects above the cement but below the oil. Measure the volume of the free fluid with a precision of  $\pm 0,2$  ml.

The volume fraction of free fluid is then calculated, as a percent, in accordance with Equation (110) above.

#### 15.5 Free-fluid test with ambient temperature static period

Pour 250 ml of the slurry from 15.3 into a 250 ml graduated glass cylinder. The zero-to-250 ml graduated portion of the cylinder shall be no less than 232 mm (9 in) nor more than 250 mm (9,8 in) in length, graduated in 2 ml increments or less. Stir the slurry by hand with a spatula during pouring to ensure a uniform sample of the slurry. The 2 h test period is initiated when the conditioned slurry is poured into the graduated tube. Seal the graduated cylinder with plastic film wrap or equivalent material to prevent evaporation. The graduated glass cylinder may be inclined at an angle to simulate wellbore deviation. Take appropriate precautions to ensure that static curing is performed in essentially vibration-free conditions.

After the 2-h test period, measure the volume of free fluid (clear or coloured fluid on top of the cement slurry inside the clear tube) with a precision of  $\pm 0,2$  ml.

The volume fraction of free fluid is then calculated, as a percent, in accordance with Equation (110) above.

#### 15.6 Sedimentation test

Pour slurry from 15.3 into a sedimentation tube until it is approximately 20 mm ( $3/4$  in) from the top. The sedimentation tube shall have an inner diameter of 25 mm  $\pm$  5 mm (0,98 in  $\pm$  0,02 in). The tube length shall be a minimum of 100 mm (3,94 in). The most common tube length is approximately 200 mm (7,9 in) (see Figure 17). Lightly grease the inside of the tube, and all joints, to ensure that it is leak-tight and so that the set

cement can be removed without damage. The tube shall be inert to well cements and shall not deform during the course of the test. Puddle the slurry in the filled tube to dislodge any air bubbles, then fill the tube completely. A top closure which allows pressure communication may be used to prevent spillage of the slurry. Place the filled tube in a water-filled preheated/precooled heating/cooling chamber in a vertical position. Preheat or precool the chamber to  $T_{BHC}$  or 88 °C (190 °F) whichever is cooler (see safety note in 15.3).

Dimensions in millimetres

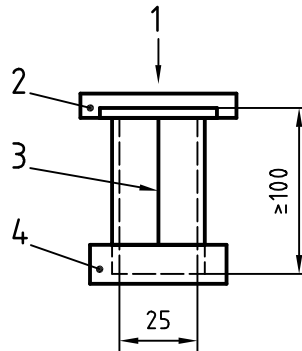

#### Key

- 1 vent hole
- 2 lid
- 3 split in tube
- 4 base

**Figure 17 — Typical sedimentation tube**

Adjust the slurry temperature further to simulate temperature changes in the wellbore. Maintain sufficient pressure to prevent boiling of the slurry (see Table 4). The pressure applied may simulate bottom-hole conditions, if desired. Avoid constant-pump cycling in order to minimize vibration. The schedules in Annex E and Clause 7 can be used to aid in selecting the temperature and pressure.

Allow the slurry to cure for 24 h or until set before removing it from the heating/cooling chamber.

Cool the chamber to 88 °C (190 °F), if required (see safety note in 15.3). Release pressure from the chamber, if required. Remove the tube from the heating/cooling chamber and bring the tube to 27 °C (80 °F) ± 6 °C (10 °F) by placing it in a water bath. Once the tube has cooled, remove the cement from the tube. Keep the cement sample immersed in water, as much as possible, to prevent it from drying out. Measure the length of the set cement specimen. Mark the specimen approximately 20 mm (3/4 in) from the bottom and from the top of the sample. Then divide the middle section, between the marks, by further marks into roughly equal pieces with a minimum of two segments. Break or cut the sample at these marks, keeping the sections in order. Keep the sections immersed in water until each is weighed. A balance with a precision of 0,01 g is necessary, a precision of 0,001 g is preferred.

The preferred method for determining the density of each section is as follows. Place a beaker containing water on the balance and tare the balance to zero. Remove a section to be measured from the water bath and gently dry it with a paper towel. Place this section on the balance beside the beaker. Record the mass and remove the section from the balance. Retare the balance to zero. Next place a noose of thin line around the section. Pick up the section by the line and suspend the section in the water in the beaker such that the sample is totally surrounded by water. The sample shall not touch the bottom or sides of the beaker. Air bubbles shall not be clinging to the section. Obtain the mass with the sample suspended in water. Remove the sample from the water and retare the balance. Repeat the procedure for each set cement section.

By applying the Archimedes Principle, calculate the relative density of each cement core section.

$$d_{\text{rel}} = \frac{m_{\text{air}}}{m_{\text{water}}} \quad (111)$$

The results are used to construct a density profile for the entire sample.

NOTE It is normal for cement slurries to experience a small density increase upon setting.

The liquid slurry density was measured prior to curing to permit the calculation of the percent density difference between the liquid sample and the set sample.

$$\% \Delta\rho = \frac{\rho_{\text{set}}}{\rho_{\text{sl}}} (100) \tag{112}$$

where

$\Delta\rho$  is the density difference;

$\rho_{\text{set}}$  is the density of the set cement segment;

$\rho_{\text{sl}}$  is the density of the cement slurry.

The density differences between slurry and set well cements can vary greatly and depend on many factors. The amount of density difference that is acceptable varies with the application. The heating/cooling, pressurizing, and cooling information that is requested in the results-Report form (Table 6) will allow other laboratories to reproduce the test. The information requested is sufficient only if the heating/cooling rate, pressurizing rate, and cool-down rate are linear. If the rates are not linear, specify the exact heating/cooling, pressurizing, and cool-down schedules on the form.

**Table 6 — Free fluid and sedimentation results-Report form**

**Slurry mixing and conditioning**

Cement temperature: \_\_\_\_\_

Mix water temperature: \_\_\_\_\_

Slurry initial temperature: \_\_\_\_\_

Slurry final temperature: \_\_\_\_\_

Time to final temperature: \_\_\_\_\_

Optional additional conditioning period: \_\_\_\_\_

Pressure profile:

Initial pressure: \_\_\_\_\_

Final pressure: \_\_\_\_\_

Time to final pressure: \_\_\_\_\_

**Free fluid test**

Length of graduated tube section: \_\_\_\_\_

Graduated tube inner diameter: \_\_\_\_\_

Test at less than 88 °C (190 °F)

Slurry volume: \_\_\_\_\_

Test temperature: \_\_\_\_\_



Test angle: \_\_\_\_\_

Measured free fluid volume: \_\_\_\_\_ ml

Vol. fraction (%) free fluid : \_\_\_\_\_

Test at greater than or equal to 88 °C (190 °F)

Slurry volume: \_\_\_\_\_

Final temperature: \_\_\_\_\_

Time to final temperature: \_\_\_\_\_ minutes

Initial test pressure: \_\_\_\_\_

Final test pressure: \_\_\_\_\_

Time to final test pressure: \_\_\_\_\_

Test angle: \_\_\_\_\_

Time to cool the slurry to 88 °C (190 °F): \_\_\_\_\_

Measured free-fluid volume: \_\_\_\_\_ ml

Vol. fraction (%) free fluid: \_\_\_\_\_

Clause 7 schedules employed: \_\_\_\_\_ Yes or \_\_\_\_\_ No

If Yes, schedule number: \_\_\_\_\_

Ambient static period

Test angle: \_\_\_\_\_

Measured free fluid volume: \_\_\_\_\_ ml

Vol. fraction (%) free fluid: \_\_\_\_\_

**Sedimentation test**

Preheated or precooled chamber temperature: \_\_\_\_\_

$T_{BHC}$ : \_\_\_\_\_

Time to  $T_{BHC}$ : \_\_\_\_\_

$T_{BHS}$ : \_\_\_\_\_

Time to  $T_{BHS}$ : \_\_\_\_\_

Initial test pressure: \_\_\_\_\_

Pressure at  $T_{BHC}$ : \_\_\_\_\_

Time to pressure at  $T_{BHC}$ : \_\_\_\_\_

Pressure at  $T_{BHS}$ : \_\_\_\_\_

Time to pressure at  $T_{BHS}$ : \_\_\_\_\_

Time at  $T_{BHS}$ : \_\_\_\_\_ hours

Time to cool the chamber to 88 °C (190 °F): \_\_\_\_\_

Length of sedimentation tube: \_\_\_\_\_

Length of set specimen: \_\_\_\_\_

Annex E schedules employed: \_\_\_\_ Yes or \_\_\_\_ No

If Yes, schedule number: \_\_\_\_\_

Clause 7 schedules employed: \_\_\_\_ Yes or \_\_\_\_ No

If Yes, schedule number: \_\_\_\_\_

Slurry density: \_\_\_\_\_

Density profile:

Top sample density: \_\_\_\_; % density diff: \_\_\_\_\_

Next sample density: \_\_\_\_; % density diff: \_\_\_\_\_

Next sample density: \_\_\_\_; % density diff: \_\_\_\_\_

Next sample density: \_\_\_\_; % density diff: \_\_\_\_\_

Next sample density: \_\_\_\_; % density diff: \_\_\_\_\_

Bottom sample density: \_\_\_\_; % density diff: \_\_\_\_\_

## 16 Compatibility of wellbore fluids

### 16.1 General

This procedure is intended for determining the degree of compatibility of wellbore fluids in cementing operations, and includes examination of rheology, static gel strength, thickening time, compressive strength, fluid loss and solids suspension. By the use of this procedure, the selection of proper preflushes and/or spacers can be made when required. User discretion shall be exercised in the selection of the portion(s) of the procedure needed.

The following test procedures are the same for preflushes and spacers. Therefore, the term spacer is used hereafter to refer to both fluids.

### 16.2 Preparation of test fluids

#### 16.2.1 Preparation of spacer

The spacer shall be freshly prepared and aged in accordance with the supplier's instructions.

#### 16.2.2 Preparation of mud

Use representative field mud. Thoroughly mix mud samples prior to testing.

#### 16.2.3 Preparation of cementing slurries

Prepare the cement slurries according to Clause 5 or Annex A. Prepare a fresh quantity of cementing slurry for each test.

#### 16.2.4 Preparation of fluid mixtures

Mixtures prepared in this clause shall be used for rheological, static gel strength, solids suspension, thickening time, compressive strength and fluid loss testing. Data for base fluids shall be obtained before mixtures are prepared. All fluid mixtures in this clause are expressed as volume fraction  $\varphi$  (percent) of the total mixture. The mixture for each test procedure shall be prepared by stirring the proper ratio of base fluids with a spatula until homogeneous. The volume of the mixture shall be sufficient to perform the desired test procedure.

### 16.3 Rheology

Rheological properties shall be determined on mixtures of cement/mud, cement/spacer and mud/spacer. The recommended ratios are 95/5, 75/25, 50/50, 25/75 and 5/95 for each fluid combination as well as a 25/50/25 mixture of mud/spacer/cement. The various-ratio mixtures may be prepared in accordance with Table 7. The rheological properties shall be measured in accordance with Clause 12. The data may be recorded on Table 8.

Table 7 — Ratio mixtures

No.	Ratio mud or cement/spacer $\varphi$ (%)	Mixing scheme
1	95/5	760 ml mud or cement / 40 ml spacer
2	75/25	100 ml spacer plus 375 ml of No. 1
3	5/95	40 ml mud or cement / 760 ml spacer
4	25/75	100 ml mud or cement plus 375 ml of No. 3
5	50/50	Equal parts of No. 1 and No. 3
6	25/50/25 mud/spacer/cement	Equal parts of No. 5 mud/spacer and No. 5 cement/spacer

### 16.4 Thickening time

Thickening-time tests shall be run on mixtures of cement/spacer. The recommended ratios are 95/5 and 75/25. The thickening-time test shall be performed in accordance with Clause 9. At the user's discretion, tests may be run on mixtures of cement/mud, spacer/mud and cement/mud/spacer.

### 16.5 Compressive strength

Compressive-strength tests shall be run on mixtures of cement/spacer. The recommended ratios are 95/5 and 75/25. The compressive-strength test shall be conducted in accordance with either Clause 7 or Clause 8. At the user's discretion, tests may be run on mixtures of cement/mud and cement/mud/spacer.

### 16.6 Solids suspension and static gel strength

**16.6.1** This procedure is designed to investigate the behaviour of fluid mixtures during and following cement slurry placement. Selection of the fluid mixtures and ratios shall be made based on results obtained from 16.4 or 16.5, at the user's discretion.

**16.6.2** Initiate a thickening-time test on the selected mixtures in accordance with Clause 9. When the specified time for heat-up has been reached, read the consistency in  $B_c$  and then cease stirring. After an elapsed time of 10 min, resume stirring while observing for any momentary gel strength development or solids settling as indicated by a maximum deflection in consistency at the instant of start-up. Continue stirring the cement slurry until one-half of the thickening time of the base cement slurry has been reached. Read the consistency in  $B_c$  and cease stirring. After an elapsed time of 10 min, resume stirring while observing for any momentary gel strength development or solids settling. This cycle may be repeated as often as desired, at the user's discretion.

### 16.7 Fluid loss

Fluid-loss tests shall be run on mixtures of cement/spacer. The recommended ratios are 95/5 and 75/25. The fluid-loss test shall be conducted in accordance with Clause 10. At the user's discretion, tests may be run on mixtures of cement/mud and cement/mud/spacer.

### **A1** 16.8 Water-wetting capability test (WWCT)

#### 16.8.1 Introduction

The water-wetting capability test (WWCT) is intended for use in determining the degree of compatibility of wellbore fluids in cementing operations. By the use of this procedure, the selection of proper preflushes and/or spacers, and/or surfactant components may be made when required. User discretion should be exercised in the selection of the portion(s) of the procedure needed. **A1**

**A1)** The WWCT is specific to evaluation of water-wetting capability of spacers and/or preflushes designed to water-wet the surfaces after these surfaces have been exposed to non-aqueous fluids, specifically oil- and synthetic-based drilling fluids. The apparent water-wetting capability of various mud/spacer interface volumes and the apparent wettability of spacer systems against oil-wetted surfaces may be evaluated using this method. This procedure does not address bulk displacement issues, nor does it directly address spacer/mud compatibility issues.

The test is applicable to aqueous spacer systems only. This procedure is not suitable for evaluating non-aqueous or non-conductive systems or mixtures of surfactants in base oils.

### 16.8.2 Method and apparatus

The apparatus provides a continuous measurement of the electrical conductivity between electrode surfaces. From the conductivity measurements, the emulsion state and apparent wettability of the fluid can be inferred if the titrating spacer fluid is conductive and the titrated drilling fluid is not. Normally, oil-external fluids are not electrically conductive. Water-based or water-external emulsion spacers are electrically conductive with the actual conductivity dependent on the solution chemistry.

### 16.8.3 Safety procedures

Observe all usual laboratory safety requirements pertaining to working with oil, synthetic, and solvent-based fluids. Note the flash points of all fluids before testing and ensure proper ventilation in the work area. All safe-handling procedures for the fluids being tested shall be observed.

### 16.8.4 Sample preparation

- Prepare a mud sample according to instructions from the supplier. Laboratory-prepared mud samples may require additional preparation, such as static aging or hot-rolling to more fully simulate field mud properties.
- Mix the spacers and/or preflush fluids to be evaluated according to manufacturer's procedures. A 500-ml volume is normally sufficient to run a single test.
- Condition all spacer fluids at anticipated Bottom Hole Circulating Temperature (BHCT) to ensure that fluids are stable and all chemicals have been conditioned and are in solution. If desired, the fluids may be conditioned for an additional 30 min  $\pm$  0,5 min at BHCT. Condition fluids under pressure using high-temperature, high-pressure (HTHP) equipment if conditioning at temperatures above 90 °C (194 °F). Fluids should be cooled below 90 ° (194 °F) before releasing pressure. Observe all safe-handling procedures for fluids being tested. This is a test conducted at atmospheric pressure. The test shall not be performed at temperatures exceeding 90 °C (194 °F).

### 16.8.5 Equipment set-up

- Prepare equipment according to instructions from supplier.
- Clean and dry test equipment before starting.
- Add the mud sample to the container.
- Heat the container to testing conditions to maintain the temperature of the test fluids. Use a stirring rate sufficient to quickly homogenise added fluids and prevent static areas. Avoid excessive shear, as it will cause air-entrainment that may affect readings and surfactant performance.

### 16.8.6 Test procedure and reporting

- Evaluate the interaction of the spacer with the drilling fluid according to manufacturer's instructions. Observe safety precautions with respect to fluid temperatures and operator safety.
- Record the starting volume of mud, volume of titrant (surfactant, flush, spacer), fluid conditioning procedure (time, temperature, etc.) and titration temperature. Slowly titrate into the mud while stirring the fluid in the test apparatus. Continue titrating until a stable conductivity measurement is reached. This indicates a water-continuous phase has been formed which is characteristic of a water-wetting state.
- Report test results as the volume percentage,  $V$ , of spacer in the mud-spacer mixture that exhibits conductivity measurements indicative of complete water wetting according to the formula:

$$V = V_s / (V_s + V_m) \times 100 \quad (113)$$

where:

$V_s$  is the volume of spacer required to change from oil to water continuous phase;

$V_m$  is the volume of mud initially in the test cell.

**EXAMPLE** For example, if 150 ml of spacer must be added to a starting mud volume of 200 ml in order to obtain a full-span reading, the result should be reported as 43 % (150 ml divided by 350 ml). **A1)**

Table 8 — Rheological compatibility of mud cement and spacer

Cement: \_\_\_\_\_

Spacer: \_\_\_\_\_

Mud: \_\_\_\_\_

Fluid mixture $\phi$ , %	Test temp. °C (°F)	Viscometer dial readings							PV $\mu_p$ mPa·s	YP $\tau_0$ Pa (lbf/in <sup>2</sup> )
		300	200	100	60	30	6	3		
100 % cement										
100 % spacer										
100 % mud										
95 % mud 5 % cement										
75 % mud 25 % cement										
50 % mud 50 % cement										
25 % mud 75 % cement										
5 % mud 95 % cement										
95 % mud 5 % spacer										
75 % mud 25 % spacer										
50 % mud 50 % spacer										
25 % mud 75 % spacer										
5 % mud 95 % spacer										
95 % cement 5 % spacer										
75 % cement 25 % spacer										
50 % cement 50 % spacer										
25 % cement 75 % spacer										
5 % cement 95 % spacer										
25 % mud 50 % spacer 25 % cement										

## 17 Pozzolans

### 17.1 General

This clause covers the recommended terminology, procedures and properties for pozzolans used in well cements.

### 17.2 Types of pozzolan

**17.2.1** Pozzolan is defined in 3.1.33 and is further described by the ASTM as siliceous and aluminous materials, which in themselves possess little or no cementitious value but will, in finely divided form and in the presence of moisture, chemically react with calcium hydroxide at ordinary temperatures to form compounds possessing cementitious properties.

**17.2.2** Class N pozzolans are naturally occurring materials such as volcanic ashes, tuffs, pumices, etc. Class N pozzolans are not widely used in well cementing.

**17.2.3** Fly ash is defined in 3.1.21 and is further described by the ASTM as finely divided residue that results from the combustion of ground or powdered coal. Fly ashes are called artificial pozzolans and are the pozzolans most commonly used in well cements.

Class F fly ash is produced as the combustion residue from anthracite or bituminous coals.

Class C fly ash is obtained by burning lignite or sub-bituminous coals. Class C fly ash can be produced with some content of calcium oxide (lime) which hydrates to form calcium hydroxide.

### 17.3 Physical and chemical properties

**17.3.1** The physical and chemical characteristics of pozzolans are listed in ASTM C 618.

**17.3.2** The average bulk density of pozzolan is used to select the storage container capacity. The average bulk density can vary between 865 kg/m<sup>3</sup> and 1 442 kg/m<sup>3</sup> (54 lbm/ft<sup>3</sup> to 90 lbm/ft<sup>3</sup>) and shall be determined by using the following procedure.

- a) Use a clean, dry 100 ml (TC type) graduated cylinder for the determination of both loose and packed apparent densities. Check the accuracy of the graduated cylinder by filling with 99,75 g of distilled water, which equals 100 ml volume at 23 °C (73 °F).
- b) Place about 200 ml of the sample to be tested in a jar of approximately 1 l (1 qt) volume, seal with a lid and hand shake to "fluff" material for 30 s.
- c) Over a 1-min period, loosely fill the tared graduate with fluffed material to the 100 ml mark. Weigh the sample and record for calculation of loose apparent bulk density.
- d) "Pack" the material from c) by gently tapping the cylinder on a hard surface, cushioned with a pad to prevent breakage of the cylinder. Record the volume of material after each 100 taps, and continue tapping until the compacted volume is unchanged. Record the packed volume of material directly from the cylinder graduations. Use this volume to calculate the packed apparent bulk density.
- e) Calculate the common field units for bulk density as follows:

$$\rho_{\text{LAB}} = \frac{1000}{100} \times m \quad (\text{SI}) \quad \boxed{A_1} \quad (114) \quad \boxed{A_1}$$

or

$$\rho_{\text{LAB}} = \frac{62,43}{100} \times m \quad (\text{USC}) \quad \boxed{\text{A}_1} \quad (115) \quad \boxed{\text{A}_1}$$

and

$$\rho_{\text{PAB}} = \frac{1000}{V} \times m \quad (\text{SI}) \quad \boxed{\text{A}_1} \quad (116) \quad \boxed{\text{A}_1}$$

or

$$\rho_{\text{PAB}} = \frac{62,43}{V} \times m \quad (\text{USC}) \quad \boxed{\text{A}_1} \quad (117) \quad \boxed{\text{A}_1}$$

where

$\rho_{\text{LAB}}$  is the loose apparent bulk density, in kilograms per cubic metre (pounds mass per cubic feet);

$\rho_{\text{PAB}}$  is the packed apparent bulk density, in kilograms per cubic metre (pounds mass per cubic feet);

$m$  is the mass, in grams, of 100 ml of loosely filled material;

$V$  is the packed volume attained by 100 ml of loosely filled material.

- f) Report average bulk density in kilograms per cubic metre (pounds mass per cubic foot) as the average of the loose and packed determinations.

**17.3.3** The relative density of pozzolan shall be measured in either a gas pycnometer, or in a Le Chatelier flask in accordance with ASTM C 188. Certain pozzolans can contain particles with a relative density less than the kerosene or naphtha specified in ASTM C 188. Suitable fluids with a relative density that prevents floating of these particles may be used. Use of a gas pycnometer is preferred for measuring the relative density of pozzolans containing unusually light particles.

The relative density of pozzolans with no particles lighter than water may determined in accordance with ASTM C 188 (Volume 04.01).

## 17.4 Slurry calculations

The terms bulk density and absolute density must be understood to prevent confusion. They both have density units, i.e. kg/m<sup>3</sup> (lbm/ft<sup>3</sup>, lbm/gal), etc. However, bulk and absolute density values for Portland cement are very different. The bulk density for Portland cement can vary, but it is usually about 1 506 kg/m<sup>3</sup> (12,6 lbm/gal or 94 lbm/ft<sup>3</sup>). The absolute density for Portland cement can vary, but it is usually about 3 138 kg/m<sup>3</sup> (26,2 lbm/gal). Bulk density includes the air space around particles, thus it is a smaller number than the absolute density. Bulk density is used to calculate storage requirements for dry powdered cement or other dry powdered materials. Absolute density is the density of the material without air around the particles and is thus a much larger number than bulk density. Absolute density is used to calculate liquid slurry properties such as slurry density, slurry water requirement, and slurry yield. Absolute density, in kg/m<sup>3</sup> (lbm/gal), can also be obtained by multiplying the relative density of a material by the density of water at 4 °C, 1 000 kg/m<sup>3</sup> (8,345 4 lbm/gal).

An item which can cause confusion, when calculating the masses of pozzolan and Portland cement for an equivalent sack of pozzolan and Portland cement blend, is that in many cementing handbooks an absolute volume factor (inverse of absolute density) is given for determining slurry calculations. The absolute densities of the pozzolan and of the Portland cement are required to perform the following calculations. The manufacturer of the pozzolan or cement shall supply the absolute density of the material (or the relative density to be used in calculating the absolute density as previously stated).



When used with Portland cement in well cementing, the amount of pozzolan is based on the absolute volume replacement of a portion of the Portland cement by an equivalent absolute volume of fly ash. These volumes are designated by a ratio of percentages such as (35:65). The first number refers to pozzolan and the second number refers to Portland cement. A (35:65) blend represents 35 % absolute volume pozzolan mixed with 65 % absolute volume cement. This designation is often not specific enough and shall be further specified. For example, 35 % Class F Fly Ash: 65 % Class G Cement would be a better designation.

As a starting point for performing slurry calculations for pozzolan/Portland cement blends, an equivalent sack of cement is defined in 3.1.19 as 42,63 kg (94 pounds) of Portland cement.

A sack of cement, 42,63 kg (94 lbm) has an absolute volume. The absolute volume can vary depending upon the absolute density of the cement. Normally, cement has an absolute density of about 3 138 kg/m<sup>3</sup> (26,20 lbm/gal). The absolute density of Portland cement can vary between 3 100 kg/m<sup>3</sup> (25,87 lbm/gal) and 3 250 kg/m<sup>3</sup> (27,12 lbm/gal). The correct absolute density value for the selected cement shall be used.

EXAMPLE 1 An example calculation, in USC units, for obtaining the absolute volume,  $V_a$ , of a sack of cement with a low absolute density of 26,00 lbm/gal is as follows:

$$V_a = \frac{94 \text{ lbm}}{26,00 \text{ lbm/U.S. gal}} = 3,62 \text{ U.S. gal}$$

Once the absolute volume of the sack of cement is known, then the pozzolan and Portland cement percentages of the absolute volume can be calculated.

EXAMPLE 2 Expanding on the above example, in USC units. If the absolute volume of a sack of cement is 3,62 gal and a 35:65 blend is wanted, then the pozzolan represents 1,27 gallons (35 % of 3,62 gal) and the Portland cement represents 2,35 gal (65 % of 3,62 gal). The absolute volume of pozzolan (1,27 gal) and the absolute volume of Portland cement (2,35 gal) are then used to calculate the pounds of each material from the absolute density values of pozzolan and Portland cement. Expanding further on the example, 2,35 gal × 26,00 lbm/gal = 61,1 lbm of Portland cement. Pozzolan absolute density can vary between 15,02 lbm/gal (1 800 kg/m<sup>3</sup>) and 24,20 lbm/gal (2 900 kg/m<sup>3</sup>), and the correct value must be known for the pozzolan material that will be used. Assume for example purposes that the absolute density of the pozzolan to be used is 20,50 lbm/ gal. Then the mass of pozzolan is 26,0 lbm (1,27 gal × 20,50 lbm/gal).

Combining the pounds of pozzolan and the pounds of cement give 87,1 lbm (61,1 lbm + 26,0 lbm) of blend. For this example, 87,1 lbm of blend would be an equivalent sack (see 3.1.19). Once the mass of the equivalent sack is known, most other additives are based on this mass.

EXAMPLE 3 For instance, let's assume that the blend has 6 % bentonite and 0,2 % retarder. The mass of bentonite per sack of blend is (6 %) × (87,1 lbm) = 5,23 lbm of bentonite per equivalent sack. The mass of retarder per sack of blend is (0,2 %) × (87,1 lbm) = 0,17 lbm per equivalent sack.

The equivalent sack mass is now known. The masses of additives in the blend are also known. Therefore slurry density and slurry yield can be calculated if the volume of mix water is known.

Conversely, if the slurry density is known, then the slurry yield and mix water requirements can be calculated. Once the value for slurry yield is determined, the number of equivalent sacks of blend for a given job can be determined from pipe and hole configuration, calliper logs, etc.

EXAMPLE 4 Assume the job requires 125 equivalent sacks. Thus, (125 sks) × (61,1 lbm/sk) = 7 638 lbm of Portland cement would be required. For the same 125-sack job, (125 sks) × (26,0 lbm/sk) = 3 250 lbm of pozzolan would be required. The masses of bentonite and retarder required are respectively, (125 sks) × (5,23 lbm/sk) = 654 lbm (296,54 kg) and (1,25 sks) × (17 lbm/sk) = 22 lbm (9,64 kg).

## 17.5 Bulk volume of a blend

17.5.1 The bulk volume of a blend of pozzolan and Portland cement will vary depending on the amount of small-particle packing between larger particles during the blending operation, and on other factors such as humidity, vibration, time, air content, and the compacting force on the materials.



17.5.2 Examples of field bulk volume measurements using actual one-sack blend masses are listed in Table 9 below:

**Table 9 — Examples of field bulk volume measurements using one-sack blend masses**

Blend	Aerated	Aerated	Packed	Packed	Average (one sack)	Average (one sack)
	m <sup>3</sup>	(ft <sup>3</sup> )	m <sup>3</sup>	(ft <sup>3</sup> )	m <sup>3</sup>	(ft <sup>3</sup> )
A <sup>a</sup>	0,033 16	1,171	0,029 17	1,03	0,031 12	1,101
B <sup>b</sup>	0,033 16	1,171	0,029 17	1,03	0,031 12	1,101
C <sup>c</sup>	0,033 16	1,171	0,024 92	0,88	0,029 02	1,025
<sup>a</sup> Blend A = (35 % Class F fly ash: 65 % Class A cement) <sup>b</sup> Blend B = (50 % Class F fly ash: 50 % Class A cement) <sup>c</sup> Blend C = (50 % Class F Fly Ash: 50 % Class H cement)						

The recommended practice for determining the bulk volume of an equivalent of pozzolan/Portland cement blend is to average the aerated (loose or fluffed) and the packed bulk volume values, as noted above.

## Annex A (normative)

### Procedure for preparation of large slurry volumes

#### A.1 General

This procedure shall only be used when an individual test requires a slurry volume greater than 600 ml. It is not intended to be used in place of Clause 5.

#### A.2 Apparatus

All apparatus shall be the same as outlined in Clause 5, except that the mixing device shall be as described in A.2.1.

##### A.2.1 Mixing device, of capacity 4 l to 5 l.

The mixing device for preparation of large slurry volumes shall be a bottom-drive, blade-type mixer. The mixing container and the mixing blade shall be constructed of corrosion-resistant material. The mixing assembly shall be constructed so that the blade can be separated from the drive mechanism. The mixing blade shall be separated from the mixing assembly and weighed prior to use, and replaced with a new blade when 10 % mass loss has occurred. The blade shall also be visually inspected for damage prior to each use and replaced as necessary. Should the mixing device leak at any time during the mixing procedure, the contents shall be discarded, the leak repaired and the procedure restarted.

An example of a mixing device in common use is shown in Figure A.1.

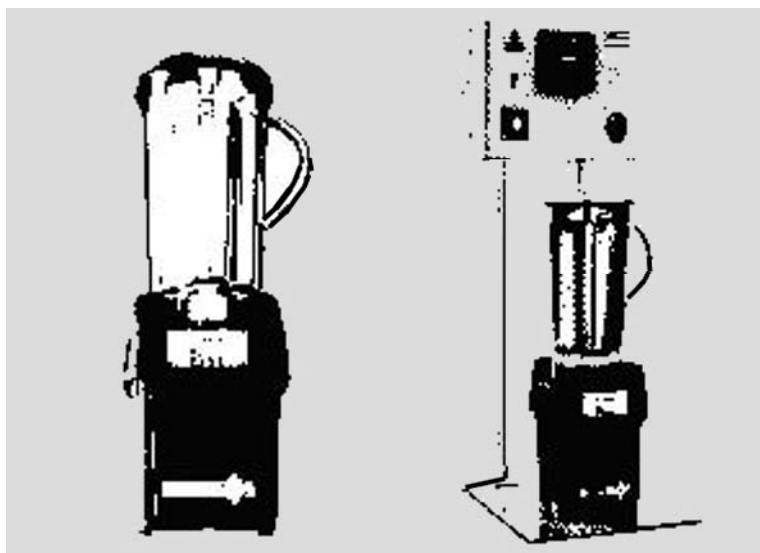

Figure A.1 — Example of a typical cement-mixing device

### A.3 Procedure

#### A.3.1 General

The procedure shall be the same as outlined in Clause 5 except as described below.

#### A.3.2 Laboratory density and volume calculations

Prepare a slurry of volume from 2 000 ml to 4 000 ml. Laboratory blend requirements can be calculated by use of the equations found in 5.3.1.4.

#### A.3.3 Mixing cement and water

Place the mixing container with the required mass of mix water and any liquid additives on the mixer base. Turn on the motor at “slow” speed (6 000 r/min or greater under no load). If additives are present in the mix water, stir at the above rotational speed to thoroughly disperse them in the mix water prior to the addition of the cement. In certain cases, the order of addition of the additives to the mixing water can be critical. Document any special mixing procedures and mixing time. Then add the cement or cement/dry additive blend to the mixing container at a uniform rate, in not more than 15 s if possible. Some slurry designs can require longer to completely wet the cement blend; however, keep the time used to add the blend at a minimum. When all of the dry materials have been added to the mix water, place the cover on the mixing container and continue mixing at “high” speed (14 000 r/min or greater under no load) for the times specified in Table A.1. If possible, measure and document rotational speed under load.

**Table A.1 — Slurry mixing time**

Slurry volume ml	High-speed mixing time s
2 000	30
3 000	45
4 000	55

## Annex B (normative)

# Calibration procedures for thermocouples, temperature-measuring systems and controllers

## B.1 General

There are several satisfactory methods for calibrating thermocouples, including methods supplied by equipment manufacturers. The reader is referred to ASTM E 220 for a more complete discussion of these procedures. No ISO procedures for calibration of temperature-measuring systems are presently available.

## B.2 Thermocouple calibration

### B.2.1 Equipment

#### B.2.1.1 General

The individual pieces of equipment needed to carry out the calibration depend on the particular technique selected. The following discussion highlights those features that need special attention, regardless of the technique.

#### B.2.1.2 Heating environment

The heating medium shall permit proper immersion of both the test thermocouple (the one being calibrated) and the reference thermocouple or reference thermometer. The medium may be a liquid bath, a fluidized solids bath, a heated block or a furnace. The equipment shall be capable of maintaining a stable temperature which is uniform throughout the test section.

#### B.2.1.3 Temperature measurement

The reference temperature of the heating medium may be measured by using either a thermometer or a thermocouple. The accuracy of the reference measuring device shall be traceable to the reference of the national body responsible for standards of temperature measurement (for example the NBS certification in the USA).

If a thermocouple is used to sense the reference temperature, the voltage output from the reference thermocouple and test thermocouple shall be determined as described in applicable national standards, such as ASTM E 220. In this case, tables of temperature vs. voltage for the type thermocouple being used must be consulted to determine the temperature. Alternatively, a direct-reading, temperature-compensated, readout instrument may be used. The accuracy of the instrument shall be traceable to national standards certification.

### B.2.2 Procedure

With the exception of the indicating instruments, the specific procedures to be followed are detailed in ASTM E 220. The items listed here are those needing special attention or related to the use of the indicated type of equipment.

- a) The test and reference thermocouple or thermometer shall be placed as close together in the heating medium as possible.

- b) After each change in the heating level, the temperature shall be allowed to remain at a stable value for 15 min before reading the reference temperature (or voltage) and the test thermocouple temperature (or voltage).
- c) Several (more than three) test temperatures which span the operating range of the equipment shall be used in the calibration procedure.
- d) If the test thermocouple does not accurately sense the temperature, a calibration curve shall be drawn and used to correct the indicated temperatures from the test thermocouple. Occasionally, small inaccuracies in thermocouple response can be compensated for during the calibration of the temperature-measuring system being used in conjunction with the thermocouple (B.3).
- e) If the test thermocouple error is greater than that specified by the manufacturer, the thermocouple shall be replaced by one that meets the thermocouple accuracy limits. The special type "J" thermocouple has error limits equal to or better than  $\pm 1\text{ }^{\circ}\text{C}$  ( $\pm 2\text{ }^{\circ}\text{F}$ ) up to  $277\text{ }^{\circ}\text{C}$  ( $530\text{ }^{\circ}\text{F}$ ).

### B.3 Calibration of temperature-measuring systems and controllers

#### B.3.1 Equipment

The calibration of temperature-measuring systems and controllers requires a millivolt source, the correct connecting thermocouple extension cable for the type thermocouple being used and, possibly, a thermometer and a table of reference voltages. Signal sources, or calibrators, are of two types, namely, uncompensated and cold-junction compensated. Several commercial calibrators are available which are cold-junction compensated and have a digital display of the temperature equivalent of the millivolt signal being supplied. The accuracy of all calibration equipment shall be traceable to national standards certification. Some older galvanometer type temperature-indicating instruments and controllers require a stronger signal for operation than the newer potentiometric and digital type temperature-measuring systems and controllers, and thus require a calibrator with sufficient signal strength to give an accurate calibration.

#### B.3.2 Procedure

Follow the manufacturer's procedure for calibrating temperature-measuring systems and controllers. For greatest accuracy, allow proper warm-up time for calibrators, temperature-measuring systems and controllers as specified by the manufacturer. The following are reminders of items needing special attention.

- a) Fit the thermocouple extension cable with a proper thermocouple-grade adapter to permit plugging it into the same receptacle used for connecting the test equipment thermocouple. Take care to ensure the correct polarity of the connections.
- b) Thermocouple calibrators with cold-junction compensation need only be properly connected with the proper thermocouple extension cable and thermocouple connectors. The temperature-measuring systems and/or controllers using this signal shall have the same temperature readout within the accuracy of the temperature or controllers as supplied by the manufacturer.
- c) Uncompensated thermocouple calibrators require a thermometer to determine the cold-junction temperature of the thermocouple extension cable connection of the calibrator. This cold-junction temperature shall be set on the calibrator by the operator.
- d) The use of an uncompensated millivolt potentiometer requires that the temperature at the calibrator/thermocouple extension cable terminals be read with a thermometer of known accuracy. The millivolt equivalent of this temperature is then subtracted from the equivalent test millivolt signal to obtain the calibrator millivolt signal used. These voltages may be found in reference millivolt/temperature tables for the type of thermocouple in use.

## Annex C (informative)

### Additional information relating to temperature determination

#### C.1 Introduction

This annex contains background information relating to the development of the cementing schedules contained in Clause 9. This information is important in the development of a correct test schedule but was considered too unwieldy to include in the well-simulation thickening-time test procedure itself. Additional information about the development of correlations to predict down-hole temperatures for cementing operations is available in API Report 10 TR 3 [6].

#### C.2 Development of predicted bottom-hole circulating temperature

The correlation for the predicted bottom-hole circulating temperature ( $T_{PBHC}$ ) was developed from temperature measurements in 66 wells. Data were obtained for wells drilled with water-based and oil-based drilling fluids. Well depths ranged from 2 362 m to 7 571 m (7 750 ft to 24 840 ft).

A maximum recorded bottom-hole static temperature ( $T_{MRBHS}$ ) and a minimum recorded bottom-hole circulating temperature ( $T_{MNRBHC}$ ) were measured in each well. Measurements were made using temperature sensors run near the end of the drill string on a clean-up trip prior to running casing. The  $T_{MRBHS}$  was the highest temperature recorded prior to commencing circulation of the wellbore. For wells used to develop the correlation, the static time (non-circulating period) ranged from 24 h to 138 h, with an average of 37,7 h. The  $T_{MNRBHC}$  was the pseudo-stabilized temperature at the end of the circulating period. The average circulation time for wells used to develop this correlation was 6,7 h.

In developing this correlation, it was determined that the circulating temperature was a function of the well depth and a temperature gradient. Other factors, such as drilling fluid type, circulating rate, circulating time, inlet temperature of the circulated fluid and drill pipe/hole size, were evaluated for their effect on the circulating temperature. No clearly distinguishable effects of these factors were observed or determined from the data collected. Therefore, the  $T_{MNRBHC}$  was correlated only to the well depth and a pseudo-temperature gradient ( $\nabla_{PT}$ ).

The  $\nabla_{PT}$  is calculated from the difference between the  $T_{MRBHS}$  and the assumed surface temperature ( $T_{AS}$ ) of 27 °C (80 °F), and the true vertical depth of the well. The  $\nabla_{PT}$  is calculated according to either of the following equations:

$$\nabla_{PT}, \text{ } ^\circ\text{C}/100 \text{ m} = \frac{T_{MRBHS} - 27 \text{ } ^\circ\text{C}}{h_{TOCTVD} 100 \text{ m}} \quad (\text{SI}) \quad (\text{C.1})$$

or

$$\nabla_{PT}, \text{ } ^\circ\text{F}/100 \text{ ft} = \frac{T_{MRBHS} - 80 \text{ } ^\circ\text{F}}{h_{TOCTVD} 100 \text{ ft}} \quad (\text{USC}) \quad (\text{C.2})$$

where

$\nabla_{PT}$  is the pseudo-temperature gradient;

$h_{TOCTVD}$  is the top-of-column true vertical depth of the well in which the temperature was measured, expressed in metres (feet).

The true temperature gradient may be different from the pseudo-temperature gradient  $\nabla_{PT}$  of the well, depending upon the difference between the  $T_{MRBHS}$  and the temperature of the undisturbed formation ( $T_{UF}$ ) at the depth at which the temperature measurement was made. The longer a wellbore is allowed to remain static prior to temperature measurement, the closer the  $T_{MRBHS}$  will be to the  $T_{UF}$ .

Although the  $T_{PBHC}$  correlation is based upon field measurements, error can be associated with its use for predicting the circulating temperature in a well. The error range between this correlation and the field-measured data from which the correlation was derived is shown in **Figure C.2**. The standard deviation is 9,2 °C (16,6 °F). Whenever possible, measurements of downhole temperatures are preferred over calculated estimates.

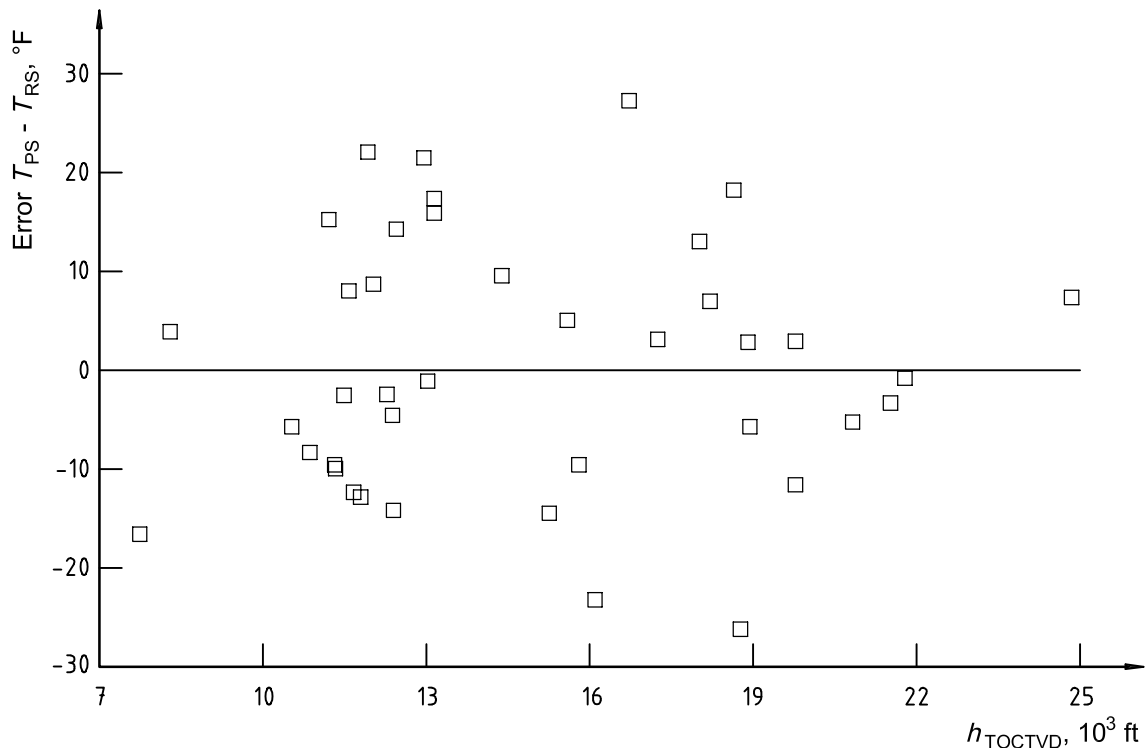

**Figure C.1 — Error range of predicted versus measured squeeze temperatures for the 40 data points used to develop the  $T_{PS}$  correlation**

### C.3 Well-simulation casing-cementing schedules

These schedules represent average well conditions developed from surveys of cementing operations. To develop these schedules, the time required for the cement slurry to reach the bottom, mud weight and starting pressure were collected from a survey of 584 casing cementing operations conducted between 1987 and 1989. Average values for each of these variables were determined for average depths from 305 m to 6 710 m (1 000 ft to 22 000 ft) in the survey data. A linear regression analysis performed on these average values was used to prepare tabular schedules.

The final temperature listed in the tabular schedules is the predicted bottom-hole circulating temperature ( $T_{PBHC}$ ). The  $T_{PBHC}$  values are taken from two sources. For well depths of 3 050 m (10 000 ft) or shallower, the  $T_{PBHC}$  are from API RP 10B [1]. For depths greater than 3 050 m (10 000 ft), the  $T_{PBHC}$  values are from the correlation developed from the well survey. Two sources for  $T_{PBHC}$  are used because of the lack of circulating-temperature data for depths shallower than 3 050 m (10 000 ft). Only two of the 66 data points used to develop the correlation were from depths shallower than 3 050 m (10 000 ft).

## C.4 Well-simulation liner-cementing schedules

These schedules represent average well conditions developed from surveys of cementing operations. To develop these schedules, the times for the leading edge of cement slurry to reach bottom, the mud weights and the starting pressures were collected from a survey of 125 liner-cementing operations conducted between 1986 and 1989. Values for each of these variables were determined in the same manner described for the development of casing-cementing thickening-time schedules. The predicted bottom-hole circulating temperatures in the liner-cementing schedules were taken from the operating casing-cementing tabular schedules for the corresponding well depth.

## C.5 Development of predicted squeeze-cementing temperature correlation

The correlation for the predicted squeeze temperature ( $T_{PS}$ ) was developed from temperature measurements in 40 wells. Data were obtained for wells drilled with water-based and oil-based drilling fluids. Well depths varied from 2 362 m to 7 571 m (7 750 ft to 24 840 ft).

A maximum recorded bottom-hole static temperature ( $T_{MRBHS}$ ) and a recorded squeeze temperature ( $T_{RS}$ ) were measured in each well. Measurements were made using temperature sensors run near the end of the drill string on a clean-up trip prior to running casing. The  $T_{MRBHS}$  was the highest temperature recorded prior to commencing circulation of the wellbore. For wells used to develop the correlation, the static time (non-circulating period) ranged from 24 h to 138 h, with an average of 38,1 h. The  $T_{RS}$  was the temperature recorded after pumping one drill-string volume of drilling fluid while taking returns up the annulus. The average time required to pump one drill-string volume was 37 min.

In developing this correlation, it was determined that the squeeze temperature was a function of the well depth and a temperature gradient. Other factors, such as drilling fluid type, circulating rate, inlet temperature of the circulating fluid, and drill pipe/hole size, were evaluated for their effect on the squeeze temperature. No clearly distinguishable effects of these other factors were observed or determined from the data collected. There was insufficient data for the wells investigated to determine the effect of fluid type (water or drilling fluids) on squeeze temperature. Therefore, the  $T_{RS}$  was correlated only to the well depth and pseudo-temperature gradient ( $\nabla_{PT}$ ).

Although the  $T_{PS}$  correlation is based upon field measurements, error can be associated with its use for predicting the squeeze temperature in a well. The error range between this correlation and the field-measured data from which the correlation was derived is shown in AC1 Figure C.1.AC1 The standard deviation is 7,2 °C (13,0 °F). Whenever possible, measurements of downhole temperatures are preferred over calculated estimates.

## C.6 Development of well-simulation squeeze-cementing tabular schedules

Two types of tabular well-simulation thickening-time schedules for squeeze-cementing operations were prepared: continuous-pumping schedules and hesitation-squeeze schedules.

To develop these schedules, the time for the cement to reach the bottom of the workstring, the fluid weight, the circulating pressure, the final squeeze pressure, and the time to apply final squeeze pressure were collected from a survey of 180 squeeze-cementing operations conducted between 1985 and 1987. Average values for each of these variables were determined for average depths from 305 m to 5 486 m (1 000 ft to 18 000 ft) in the survey data. These average values were curve-fit using a polynomial function, and the predicted values from the curve fit were used to prepare tabular schedules. Starting surface pressures were taken from squeeze-cementing tabular schedules in API Spec 10 [2]. The  $T_{PS}$  in the tabular schedules are from the correlation.



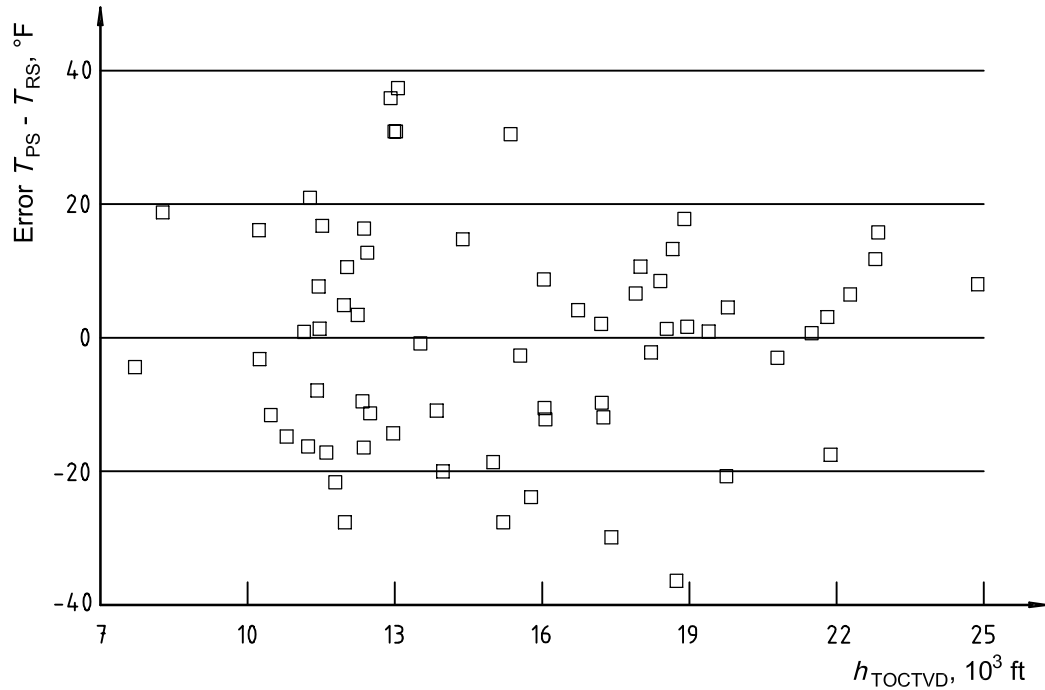

**Figure C.2 — Error range of predicted versus measured squeeze temperatures for the 66 data points used to develop the  $T_{PBHC}$  correlation**

For continuous-pumping squeeze tabular schedules, the temperature of the cement slurry is increased to the  $T_{PS}$  and the  $p_{BH}$  within the amount of time required for the leading edge of cement slurry to reach the bottom of the workstring. The amount of time is based upon the correlation for average time to bottom developed from the survey data. The temperature is held constant at the  $T_{PS}$  while the pressure is increased to the final squeeze pressure over time. The time over which the pressure is increased is based upon the correlation developed from the survey data. Temperature is held at the  $T_{PS}$  and pressure is held at the final squeeze pressure for the duration of the thickening-time test.

Hesitation-squeeze schedules are the same as the continuous-pumping squeeze-cementing schedules until the squeeze pressure is reached. Pressure on the cement slurry is held at the final squeeze pressure for the duration of the test. After reaching the final squeeze pressure, the hesitation-squeeze schedule increases the temperature of the slurry from the  $T_{PS}$  to the pseudo-undisturbed temperature ( $T_{PU}$ ) at a heating rate of 0,1 °C/min (0,2 °F/min). The  $T_{PU}$  is calculated in SI units using the following equation:

$$T_{PU} = [(\nabla_{PT})(h_{TOCTVD}/100)] + 27 \text{ °C} \quad \text{(SI units) (C.3)}$$

where

$T_{PU}$  is the pseudo-undisturbed temperature, expressed in °C;

$\nabla_{PT}$  is the pseudo-temperature gradient, expressed in °C/100 m;

$h_{TOCTVD}$  is the true vertical depth, expressed in metres;

27 °C is the assumed surface temperature.

or in USC units:

$$T_{PU} = [(\nabla_{PT})(h_{TOCTVD}/100)] + 80 \text{ } ^\circ\text{F} \quad (\text{USC units}) \quad (\text{C.4})$$

where

- $T_{PU}$  is the pseudo-undisturbed temperature, expressed in  $^\circ\text{F}$ ;
- $\nabla_{PT}$  is the pseudo-temperature gradient, expressed in  $^\circ\text{F}/100 \text{ ft}$
- $h_{TOCTVD}$  is the true vertical depth, expressed in feet;
- $80 \text{ } ^\circ\text{F}$  is the assumed surface temperature.

The motor on the consistometer is cycled off (10 min) and on (5 min) during this final heating period. The motor cycling is designed to detect viscosity increases during static periods while “hesitating” during a squeeze operation. Cycling of the motor is continued for the duration of the test.

## C.7 Application of predicted circulating and squeeze temperatures to offshore wells

Some of the data used in the development of correlations for predicting bottom-hole circulating temperatures and squeeze temperatures were from offshore wells. Only data from offshore wells in less than 250 ft of water were included in the data set used to develop the correlations. Also, the water depth was less than three percent of the true vertical depth at which the temperature was measured. The  $\nabla_{PT}$  was calculated from sea level using a  $T_{AS}$  of  $27 \text{ } ^\circ\text{C}$  ( $80 \text{ } ^\circ\text{F}$ ).

$T_{PBHC}$  and  $T_{PS}$  from the correlations developed from this data may be significantly different from the temperatures at shallow depths below the seafloor in offshore wells. Whenever possible, measured temperatures are preferred over predicted temperatures.

## C.8 Plug-cementing tailored schedules

The squeeze temperatures predicted using the equations were developed from down-hole temperature measurements after one workstring volume had been circulated. The average circulating time for the data used to prepare the  $T_{PS}$  correlation was 36,9 min. Predicted circulating temperatures from API RP 10B [1] were developed from downhole temperature measurements after a period of circulation typically greater than 2 h.

Therefore, selection of test temperature for plug cementing shall be based upon the anticipated amount of circulation time prior to the cementing operation. Whenever possible, use measured temperatures over predicted values.

## C.9 Explanation of some temperature-related terms

### C.9.1 Assumed surface temperature ( $T_{AS}$ )

The assumed temperature at the surface is used for purposes of calculating a pseudo-temperature gradient ( $\nabla_{PT}$ ). The 1974 API data set used a  $T_{AS}$  value of  $24 \text{ } ^\circ\text{C}$  ( $75 \text{ } ^\circ\text{F}$ ) for calculation of the pseudo-temperature gradient values listed in earlier API well cement standards. The 1984 API data set used a  $T_{AS}$  value of  $27 \text{ } ^\circ\text{C}$  ( $80 \text{ } ^\circ\text{F}$ ), as does the 1991 selected data set.

### C.9.2 Average time-to-bottom

This value was used in compiling the tabular casing and liner schedules found in Clause 7. These values are based on actual times-to-bottom at each depth, obtained from the API Casing Survey taken from 1987 to 1989 (covering 584 data points). The casing survey was for full casing strings and a few inner-string jobs, but no liners.

The curve for average time-to-bottom was developed by dividing the survey data into depth ranges, computing average time-to-bottom for each depth range, and using a simple linear regression analysis curve fit to these average values.

### C.9.3 Maximum recorded bottom-hole static temperature ( $T_{MRBHS}$ )

The  $T_{MRBHS}$  is the maximum temperature recorded at the bottom of a wellbore, after a static period (non-circulation normally of up to 24 h or more) and prior to start of circulation. The longer the static period of non-circulation, the closer the  $T_{MRBHS}$  will approach the undisturbed formation temperature ( $T_{UF}$ ). The  $T_{MRBHS}$  value is preferably determined by a temperature sensor run in the drill string that is tripped into the wellbore during a clean-up trip after logging and prior to running casing. Maximum recorded log temperatures are sometimes used. The 1974 data, used in API Spec 10 [2], consisted of 41 data points that were used to determine the pseudo-temperature gradients contained in the "cementing schedules." These data points were obtained by temperature sensors at various static times from 7 h to 76 h. The average static period for all wells measured was 27,9 h. The 1991 selected set of data, used in API RP 10B [1], consists of 66 data points used to determine the pseudo-temperature gradients contained in the "casing cementing schedules" and equations. These data points also were obtained by temperature sensors at various static times from 24 h to 138 h. The average static period was also shown to be 37,7 h. One attribute of the 1991 selected data set was that all static times were greater than 24 h.

### C.9.4 Minimum recorded bottom-hole circulating temperature ( $T_{MNRBHC}$ )

The  $T_{MNRBHC}$  is the minimum temperature recorded at the bottom of a wellbore, after circulation time sufficient to achieve a nearly stabilized or steady-state circulating temperature. The  $T_{MNRBHC}$  is usually determined by a temperature sensor run in the drill string that is tripped into the wellbore during a clean-up trip after logging and prior to running casing. The temperature is obtained, after some time period of circulating the wellbore, prior to tripping the pipe off bottom. The  $T_{MNRBHC}$  is dependent upon well geometry, fluid properties, circulation rate, etc., and is not necessarily the minimum bottom-hole circulating temperature of a cement slurry.

### C.9.5 Predicted bottom-hole circulating temperature ( $T_{PBHC}$ )

The  $T_{PBHC}$  is the predicted temperature obtained from Clause 9, tabulated schedules or equations, for the bottom-hole depth and pseudo-temperature gradient ( $\nabla_{PT}$ ). This is a calculated value based on field data and associated correlation techniques, used to develop the schedules and equations. When using the tabulated schedules, this is the temperature listed for the maximum time shown in that schedule. The  $T_{PBHC}$  is used for both casing and liner schedules. The actual wellbore temperature is dependent upon well geometry, fluid properties, circulation rate, etc., and is not necessarily the bottom-hole circulating temperature of a cement slurry.

### C.9.6 Predicted squeeze temperature ( $T_{PS}$ )

The  $T_{PS}$  is the predicted squeeze temperature obtained using Clause 9 tabulated squeeze schedules or equations, for the selected depth and temperature gradient. When using the tabulated continuous-pumping squeeze schedules, the  $T_{PS}$  is the temperature listed for the maximum time shown in that schedule. When using the tabulated hesitation-squeeze schedules, the  $T_{PS}$  is the temperature in the schedule at the end of the first temperature ramp. The actual wellbore squeeze temperature is dependent upon well geometry, fluid properties, circulation rate, circulating time and inlet temperature of the fluid.

### C.9.7 Pseudo-temperature gradient ( $\nabla_{PT}$ )

This is a calculated value based on field data and associated correlation techniques which were used to develop the schedules and equations. The  $\nabla_{PT}$  is a temperature change per unit of depth, determined by an equation using an assumed surface temperature ( $T_{AS}$ ), defined as 27 °C (80 °F), and a maximum recorded bottom-hole static temperature ( $T_{MRBHS}$ ). See Equation (C.1).

The  $\nabla_{PT}$  is used in Clause 9 to develop well-simulation testing schedules of temperature and pressure versus time.

### C.9.8 Pseudo-undisturbed temperature ( $T_{PU}$ )

This is the temperature at a given depth calculated in Equations (C.3) and (C.4).

The  $T_{PU}$  at the bottom of the wellbore is equal to the maximum recorded bottom-hole static temperature ( $T_{MRBHS}$ ). It is intended that the static time, for this equation, equal or exceed 24 h.

### C.9.9 Recorded squeeze temperature ( $T_{RS}$ )

This is the temperature recorded at the end of the workstring at the calculated time when a volume of fluid equal to the internal volume of the workstring has been circulated. This also represents the temperature at the time when the leading edge of cement slurry would reach the end of the workstring. The  $T_{RS}$  is usually determined by a temperature sensor run in the workstring that is tripped into the wellbore during a clean-up trip. The workstring for the 1991 selected data set was at the bottom of the wellbore and the data were usually collected after logging and prior to running casing. The actual wellbore squeeze temperature is dependent upon well geometry, fluid properties, circulation rate, circulating time and inlet temperature of the fluid.

### C.9.10 Static time

This is the amount of time between the end of the last circulation of the wellbore and the time at which the maximum recorded bottom-hole static temperature ( $T_{MRBHS}$ ) was observed.

### C.9.11 Undisturbed formation temperature ( $T_{UF}$ )

This is the temperature of the geologic formation, at the depth of interest, prior to its first penetration by a drill bit, or the temperature attained at a depth in a well after the well is shut in for a period long enough to return to the adjacent undisturbed (virgin) geological formation temperature.

## Annex D (normative)

### Alternative apparatus for well thickening-time tests

#### D.1 General

This annex presents a description of an alternative pressurized consistometer for the well-simulation thickening-time testing of cement slurries.

#### D.2 Apparatus

**D.2.1 Consistometer**, having a rotating paddle and a stationary cup design and constructed such that the cement slurry can be subjected to the temperatures and pressures required by the well-simulation test schedules described in 9.5.

Paddle torque is sensed by motor load or alternate torque sensors to provide slurry consistency measurements equivalent to those of the typical consistometer described in 9.2. Slurry temperature and pressure controls are provided as depicted in Figure D.1 and Figure D.2. The apparatus shall be capable of duplicating the test conditions and measurements required of the typical consistometer described in 9.2.

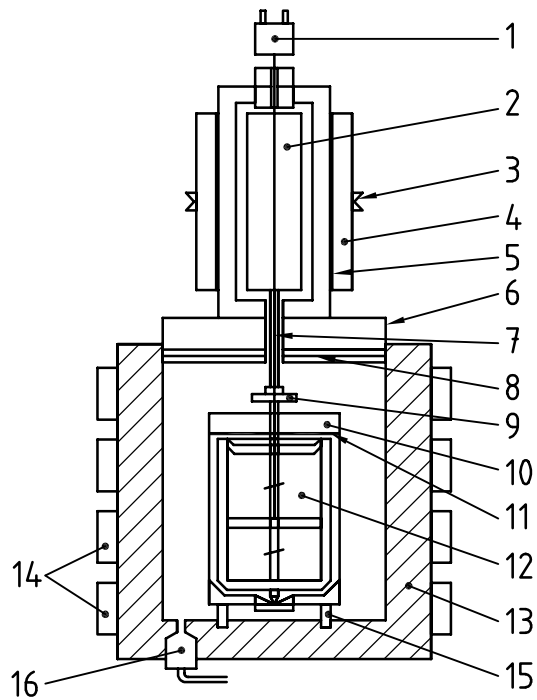

**Key**

- 1 slurry temperature sensor
- 2 inner magnet
- 3 drive pulley
- 4 outer magnet
- 5 pressure housing
- 6 lid
- 7 drive shaft
- 8 lid seal
- 9 paddle drive coupling
- 10 pressure medium
- 11 isolator (slurry/pressure medium)
- 12 slurry container and slurry
- 13 pressure chamber
- 14 heater elements
- 15 slurry container retainers
- 16 fluid fill/empty

**Figure D.1 — Alternative consistometer design for well-simulation thickening time, Example 1**

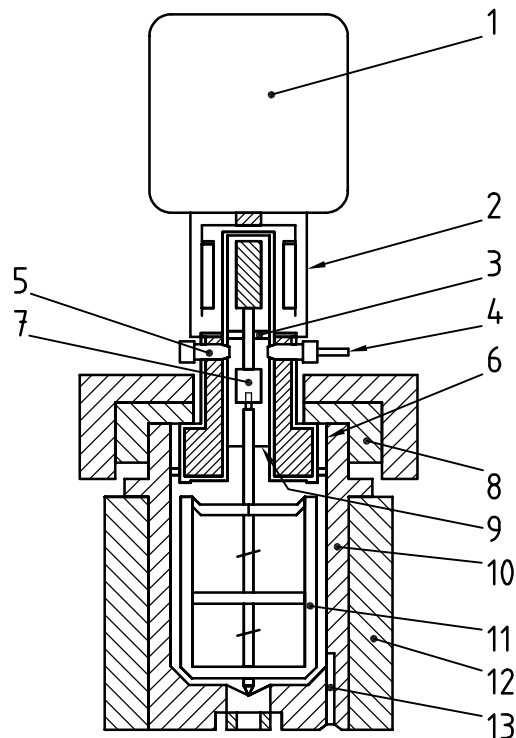

#### Key

- 1 motor/generator
- 2 magnetic drive
- 3 pressure-transmitting seal
- 4 oil-pressuring port
- 5 air vent
- 6 auxiliary thermocouple
- 7 mechanical coupling
- 8 auxiliary heater jacket
- 9 oil/cement interface
- 10 slurry pressure vessel
- 11 rotating paddle
- 12 main heating/cooling jacket
- 13 main thermocouple well

**Figure D.2 — Alternative consistometer design for well-simulation thickening time, Example 2**

### D.3 Calibration

The equipment manufacturer's procedures for the calibration of the pressurized consistometer, including consistency measurement, temperature measurement, temperature controllers, motor speed, timer and pressure gauges, shall be followed. The same specifications and frequency of calibration apply to the use of this alternative device as the typical consistometer of 9.2.

### D.4 Test procedure

The equipment manufacturer's detailed procedures for the operation and maintenance of the equipment shall be followed and shall satisfy the intent of the general procedures in Clause 9. Some modifications may be necessary to accommodate the design variations of the alternative device. Do not exceed manufacturer's safety limits.

## Annex E (informative)

### Cementing schedules

Table E.1 — Casing well-simulation tests

1	2		3		4		5		6		7	
Depth ( $h_{\text{TOCTVD}}$ )	Temperature gradient, °C/100 m depth (°F/100 ft depth)											
	1,6 (0,9)		2,0 (1,1)		2,4 (1,3)		2,7 (1,5)		3,1 (1,7)		3,5 (1,9)	
	Temperature											
	°C	(°F)	°C	(°F)	°C	(°F)	°C	(°F)	°C	(°F)	°C	(°F)
305 m (1 000 ft)	27	(80)	27	(80)	27	(80)	27	(80)	27	(80)	27	(80)
610 m (2 000 ft)	32	(89)	32	(89)	32	(90)	32	(90)	33	(91)	33	(91)
1 020 m (4 000 ft)	37	(99)	38	(100)	38	(101)	39	(102)	39	(103)	40	(104)
1 830 m (6 000 ft)	44	(112)	46	(114)	47	(116)	48	(118)	49	(120)	52	(126)
2 440 m (8 000 ft)	52	(126)	54	(129)	57	(135)	60	(140)	63	(146)	71	(160)
3 050 m (10 000 ft)	61	(141)	63	(146)	70	(158)	75	(167)	82	(180)	93	(200)
3 660 m (12 000 ft)	64	(148)	74	(165)	84	(183)	94	(201)	104	(219)	113	(236)
4 270 m (14 000 ft)	73	(164)	85	(185)	97	(207)	109	(228)	121	(250)	133	(271)
4 880 m (16 000 ft)	83	(182)	97	(207)	112	(233)	126	(258)	140	(284)	154	(309)
5 490 m (18 000 ft)	94	(201)	111	(231)	127	(261)	144	(291)	161	(321)	177	(350)
6 100 m (20 000 ft)	106	(222)	124	(256)	144	(291)	163	(326)	182	(360)	202	(395)
6 710 m (22 000 ft)	118	(244)	140	(284)	162	(324)	184	(364)	207	(404)	229	(444)



Table E.2 — Liner well-simulation tests

1	2		3		4		5		6		7	
Depth ( $h_{\text{TOCTVD}}$ )	Temperature gradient, °C/100 m depth (°F/100 ft depth)											
	1,6	(0,9)	2,0	(1,1)	2,4	(1,3)	2,7	(1,5)	3,1	(1,7)	3,5	(1,9)
	Temperature											
	°C	(°F)	°C	(°F)	°C	(°F)	°C	(°F)	°C	(°F)	°C	(°F)
305 m (1 000 ft)	27	(80)	27	(80)	27	(80)	27	(80)	27	(80)	27	(80)
610 m (2 000 ft)	32	(89)	32	(89)	32	(90)	32	(90)	33	(91)	33	(91)
1 020 m (4 000 ft)	37	(99)	38	(100)	38	(101)	39	(102)	39	(103)	40	(104)
1 830 m (6 000 ft)	44	(112)	46	(114)	47	(116)	48	(118)	49	(120)	52	(126)
2 440 m (8 000 ft)	52	(126)	54	(129)	57	(135)	60	(140)	63	(146)	71	(160)
3 050 m (10 000 ft)	61	(141)	63	(146)	70	(158)	75	(167)	82	(180)	93	(200)
3 660 m (12 000 ft)	64	(148)	74	(165)	84	(183)	94	(201)	104	(219)	113	(236)
4 270 m (14 000 ft)	73	(164)	85	(185)	97	(207)	109	(228)	121	(250)	133	(271)
4 880 m (16 000 ft)	83	(182)	97	(207)	112	(233)	126	(258)	140	(284)	154	(309)
5 490 m (18 000 ft)	94	(201)	111	(231)	127	(261)	144	(291)	161	(321)	177	(350)
6 100 m (20 000 ft)	106	(222)	124	(256)	144	(291)	163	(326)	182	(360)	202	(395)
6 710 m (22 000 ft)	118	(244)	140	(284)	162	(324)	184	(364)	207	(404)	229	(444)

Table E.3 — Continuous-pumping squeeze well-simulation tests

1	2	3	4	5	6	7	8
Time	Pressure	Temperature gradient, °C/100 m depth (°F/100 ft depth)					
		1,6 (0,9)	2,0 (1,1)	2,4 (1,3)	2,7 (1,5)	3,1 (1,7)	3,5 (1,9)
min	kPa (psi)	Temperature					
		°C (°F)	°C (°F)	°C (°F)	°C (°F)	°C (°F)	°C (°F)
		Depth: 305 m (1 000 ft)			Mud density: 1,10 kg/l (9,2 lbm/gal)		
0	3 400 (500)	27 (80)	27 (80)	27 (80)	27 (80)	27 (80)	27 (80)
1	3 400 (500)	27 (80)	27 (80)	28 (82)	28 (83)	29 (85)	30 (86)
2	3 600 (520)	27 (80)	27 (80)	28 (82)	28 (83)	29 (85)	30 (86)
3	3 700 (540)	27 (80)	27 (80)	28 (82)	28 (83)	29 (85)	30 (86)
4	3 900 (560)	27 (80)	27 (80)	28 (82)	28 (83)	29 (85)	30 (86)
5	4 000 (580)	27 (80)	27 (80)	28 (82)	28 (83)	29 (85)	30 (86)
6	4 100 (600)	27 (80)	27 (80)	28 (82)	28 (83)	29 (85)	30 (86)
7	4 300 (620)	27 (80)	27 (80)	28 (82)	28 (83)	29 (85)	30 (86)
8	4 400 (640)	27 (80)	27 (80)	28 (82)	28 (83)	29 (85)	30 (86)
9	4 600 (660)	27 (80)	27 (80)	28 (82)	28 (83)	29 (85)	30 (86)
10	4 700 (680)	27 (80)	27 (80)	28 (82)	28 (83)	29 (85)	30 (86)
11	4 800 (700)	27 (80)	27 (80)	28 (82)	28 (83)	29 (85)	30 (86)
12	5 000 (720)	27 (80)	27 (80)	28 (82)	28 (83)	29 (85)	30 (86)
13	5 100 (740)	27 (80)	27 (80)	28 (82)	28 (83)	29 (85)	30 (86)
14	5 200 (760)	27 (80)	27 (80)	28 (82)	28 (83)	29 (85)	30 (86)
15	5 400 (780)	27 (80)	27 (80)	28 (82)	28 (83)	29 (85)	30 (86)
Ramp (deg/min)		0,00 (0,00)	0,00 (0,00)	1,11 (2,00)	1,67 (3,00)	2,78 (5,00)	3,33 (6,00)
Ramp time		1 min					
Temp. dwell		14 min					
Pressure rate (per min)		0 kPa (0 psi) for 1 min, then 143 kPa (20 psi) for 14 min					

Table E.3 (continued)

1	2	3	4	5	6	7	8		
Time	Pressure	Temperature gradient, °C/100 m depth (°F/100 ft depth)							
		1,6 (0,9)	2,0 (1,1)	2,4 (1,3)	2,7 (1,5)	3,1 (1,7)	3,5 (1,9)		
		Temperature							
min	kPa (psi)	°C (°F)	°C (°F)	°C (°F)	°C (°F)	°C (°F)	°C (°F)	°C (°F)	
		Depth: 610 m (2 000 ft)				Mud density: 1,13 kg/l (9,40 lbm/gal)			
0	3 400 (500)	27 (80)	27 (80)	27 (80)	27 (80)	27 (80)	27 (80)	27 (80)	
1	4 100 (600)	28 (82)	28 (82)	28 (83)	29 (84)	29 (85)	30 (86)	30 (86)	
2	4 800 (700)	29 (84)	29 (85)	30 (86)	31 (88)	32 (89)	33 (91)	33 (91)	
3	5 500 (800)	30 (85)	31 (87)	31 (89)	33 (91)	34 (94)	36 (96)	36 (96)	
4	6 200 (900)	30 (86)	32 (89)	33 (92)	35 (95)	37 (98)	38 (101)	38 (101)	
5	6 500 (940)	30 (86)	32 (89)	33 (92)	35 (95)	37 (98)	38 (101)	38 (101)	
6	6 800 (980)	30 (86)	32 (89)	33 (92)	35 (95)	37 (98)	38 (101)	38 (101)	
7	7 000 (1 020)	30 (86)	32 (89)	33 (92)	35 (95)	37 (98)	38 (101)	38 (101)	
8	7 300 (1 060)	30 (86)	32 (89)	33 (92)	35 (95)	37 (98)	38 (101)	38 (101)	
9	7 600 (1 100)	30 (86)	32 (89)	33 (92)	35 (95)	37 (98)	38 (101)	38 (101)	
10	7 900 (1 140)	30 (86)	32 (89)	33 (92)	35 (95)	37 (98)	38 (101)	38 (101)	
11	8 100 (1 180)	30 (86)	32 (89)	33 (92)	35 (95)	37 (98)	38 (101)	38 (101)	
12	8 400 (1 220)	30 (86)	32 (89)	33 (92)	35 (95)	37 (98)	38 (101)	38 (101)	
13	8 700 (1 260)	30 (86)	32 (89)	33 (92)	35 (95)	37 (98)	38 (101)	38 (101)	
14	9 000 (1 300)	30 (86)	32 (89)	33 (92)	35 (95)	37 (98)	38 (101)	38 (101)	
15	9 200 (1 340)	30 (86)	32 (89)	33 (92)	35 (95)	37 (98)	38 (101)	38 (101)	
16	9 500 (1 380)	30 (86)	32 (89)	33 (92)	35 (95)	37 (98)	38 (101)	38 (101)	
17	9 800 (1 420)	30 (86)	32 (89)	33 (92)	35 (95)	37 (98)	38 (101)	38 (101)	
18	10 100 (1 460)	30 (86)	32 (89)	33 (92)	35 (95)	37 (98)	38 (101)	38 (101)	
19	10 300 (1 500)	30 (86)	32 (89)	33 (92)	35 (95)	37 (98)	38 (101)	38 (101)	
20	10 600 (1 540)	30 (86)	32 (89)	33 (92)	35 (95)	37 (98)	38 (101)	38 (101)	
Ramp (deg/min)		0,83 (1,50)	1,25 (2,25)	1,67 (3,00)	2,08 (3,75)	2,50 (4,50)	2,92 (5,25)	2,92 (5,25)	
Ramp time		4 min							
Temp. dwell		16 min							
Pressure rate (per min)		700 kPa (100 psi) for 4 min, then 275 kPa (40 psi) for 16 min							

Table E.3 (continued)

1	2	3	4	5	6	7	8
Time	Pressure	Temperature gradient, °C/100 m depth (°F/100 ft depth)					
		1,6 (0,9)	2,0 (1,1)	2,4 (1,3)	2,7 (1,5)	3,1 (1,7)	3,5 (1,9)
		Temperature					
min	kPa (psi)	°C (°F)	°C (°F)	°C (°F)	°C (°F)	°C (°F)	°C (°F)
		Depth: 1 220 m (4 000 ft)			Mud density: 1,16 kg/l (9,7 lbm/gal)		
0	3 400 (500)	27 (80)	27 (80)	27 (80)	27 (80)	27 (80)	27 (80)
1	4 600 (660)	28 (82)	28 (83)	29 (84)	29 (84)	29 (85)	30 (86)
2	5 700 (820)	29 (84)	30 (86)	31 (87)	32 (89)	32 (90)	33 (92)
3	6 800 (980)	31 (87)	32 (89)	33 (91)	34 (93)	35 (95)	36 (97)
4	7 900 (1 140)	32 (89)	33 (92)	35 (95)	36 (97)	38 (100)	39 (103)
5	9 000 (1 300)	33 (91)	34 (94)	37 (98)	39 (102)	41 (105)	43 (109)
6	10 100 (1 460)	34 (93)	36 (97)	39 (102)	41 (106)	43 (110)	46 (115)
7	11 200 (1 620)	36 (96)	38 (100)	41 (106)	43 (110)	46 (115)	49 (120)
8	12 300 (1 780)	37 (98)	39 (103)	43 (109)	46 (115)	49 (120)	52 (126)
9	13 400 (1 940)	38 (100)	41 (106)	45 (113)	48 (119)	52 (125)	56 (132)
10	13 800 (2 005)	38 (100)	41 (106)	45 (113)	48 (119)	52 (125)	56 (132)
11	14 300 (2 070)	38 (100)	41 (106)	45 (113)	48 (119)	52 (125)	56 (132)
12	14 700 (2 135)	38 (100)	41 (106)	45 (113)	48 (119)	52 (125)	56 (132)
13	15 200 (2 200)	38 (100)	41 (106)	45 (113)	48 (119)	52 (125)	56 (132)
14	15 600 (2 265)	38 (100)	41 (106)	45 (113)	48 (119)	52 (125)	56 (132)
15	16 100 (2 330)	38 (100)	41 (106)	45 (113)	48 (119)	52 (125)	56 (132)
16	16 500 (2 395)	38 (100)	41 (106)	45 (113)	48 (119)	52 (125)	56 (132)
17	17 000 (2 460)	38 (100)	41 (106)	45 (113)	48 (119)	52 (125)	56 (132)
18	17 400 (2 525)	38 (100)	41 (106)	45 (113)	48 (119)	52 (125)	56 (132)
19	17 900 (2 590)	38 (100)	41 (106)	45 (113)	48 (119)	52 (125)	56 (132)
20	18 300 (2 655)	38 (100)	41 (106)	45 (113)	48 (119)	52 (125)	56 (132)
21	18 800 (2 720)	38 (100)	41 (106)	45 (113)	48 (119)	52 (125)	56 (132)
22	19 200 (2 785)	38 (100)	41 (106)	45 (113)	48 (119)	52 (125)	56 (132)
23	19 700 (2 850)	38 (100)	41 (106)	45 (113)	48 (119)	52 (125)	56 (132)
24	20 100 (2 915)	38 (100)	41 (106)	45 (113)	48 (119)	52 (125)	56 (132)
25	20 500 (2 980)	38 (100)	41 (106)	45 (113)	48 (119)	52 (125)	56 (132)
Ramp (deg/min)		1,23 (2,22)	1,61 (2,89)	2,04 (3,67)	2,41 (4,33)	2,78 (5,00)	3,21 (5,78)
Ramp time		9 min					
Temp. dwell		16 min					
Pressure rate per min		1 111 kPa (160 psi) for 9 min, then 444 kPa (65 psi) for 16 min					

Table E.3 (continued)

1	2	3	4	5	6	7	8		
Time	Pressure	Temperature gradient, °C/100 m depth (°F/100 ft depth)							
		1,6 (0,9)	2,0 (1,1)	2,4 (1,3)	2,7 (1,5)	3,1 (1,7)	3,5 (1,9)		
		Temperature							
min	kPa (psi)	°C (°F)	°C (°F)	°C (°F)	°C (°F)	°C (°F)	°C (°F)	°C (°F)	
Depth: 1 830 m (6 000 ft)				Mud density: 1,22 kg/l (10,2 lbm/gal)					
0	5 500 (800)	27 (80)	27 (80)	27 (80)	27 (80)	27 (80)	27 (80)	27 (80)	
1	6 700 (970)	28 (83)	28 (83)	29 (84)	29 (85)	29 (85)	30 (86)	30 (86)	
2	7 900 (1 140)	29 (85)	30 (86)	31 (88)	32 (89)	32 (90)	33 (92)	33 (92)	
3	9 000 (1 310)	31 (88)	32 (89)	33 (92)	34 (94)	36 (96)	37 (98)	37 (98)	
4	10 200 (1 480)	32 (90)	34 (93)	35 (95)	37 (98)	38 (101)	40 (104)	40 (104)	
5	11 400 (1 650)	34 (93)	36 (96)	37 (99)	39 (103)	41 (106)	43 (110)	43 (110)	
6	12 500 (1 820)	35 (95)	37 (99)	39 (103)	42 (107)	44 (111)	47 (116)	47 (116)	
7	13 700 (1 990)	37 (98)	39 (102)	42 (107)	44 (112)	47 (116)	50 (122)	50 (122)	
8	14 900 (2 160)	38 (100)	41 (105)	44 (111)	47 (117)	50 (122)	53 (127)	53 (127)	
9	16 100 (2 330)	39 (103)	42 (108)	46 (115)	49 (121)	53 (127)	56 (133)	56 (133)	
10	17 200 (2 500)	41 (105)	44 (111)	48 (119)	52 (126)	56 (132)	59 (139)	59 (139)	
11	18 400 (2 670)	42 (108)	46 (115)	50 (122)	54 (130)	58 (137)	63 (145)	63 (145)	
12	19 600 (2 840)	43 (110)	48 (118)	52 (126)	57 (135)	62 (143)	66 (151)	66 (151)	
13	20 800 (3 010)	45 (113)	49 (121)	54 (130)	59 (139)	64 (148)	69 (157)	69 (157)	
14	21 900 (3 180)	46 (115)	51 (124)	57 (134)	62 (144)	67 (153)	73 (163)	73 (163)	
15	22 400 (3 250)	46 (115)	51 (124)	57 (134)	62 (144)	67 (153)	73 (163)	73 (163)	
16	22 900 (3 320)	46 (115)	51 (124)	57 (134)	62 (144)	67 (153)	73 (163)	73 (163)	
17	23 400 (3 390)	46 (115)	51 (124)	57 (134)	62 (144)	67 (153)	73 (163)	73 (163)	
18	23 900 (3 460)	46 (115)	51 (124)	57 (134)	62 (144)	67 (153)	73 (163)	73 (163)	
19	24 300 (3 530)	46 (115)	51 (124)	57 (134)	62 (144)	67 (153)	73 (163)	73 (163)	
20	24 800 (3 600)	46 (115)	51 (124)	57 (134)	62 (144)	67 (153)	73 (163)	73 (163)	
21	25 300 (3 670)	46 (115)	51 (124)	57 (134)	62 (144)	67 (153)	73 (163)	73 (163)	
22	25 800 (3 740)	46 (115)	51 (124)	57 (134)	62 (144)	67 (153)	73 (163)	73 (163)	
23	26 300 (3 810)	46 (115)	51 (124)	57 (134)	62 (144)	67 (153)	73 (163)	73 (163)	
24	26 800 (3 880)	46 (115)	51 (124)	57 (134)	62 (144)	67 (153)	73 (163)	73 (163)	
25	27 200 (3 950)	46 (115)	51 (124)	57 (134)	62 (144)	67 (153)	73 (163)	73 (163)	
26	27 700 (4 020)	46 (115)	51 (124)	57 (134)	62 (144)	67 (153)	73 (163)	73 (163)	
27	28 200 (4 090)	46 (115)	51 (124)	57 (134)	62 (144)	67 (153)	73 (163)	73 (163)	
28	28 700 (4 160)	46 (115)	51 (124)	57 (134)	62 (144)	67 (153)	73 (163)	73 (163)	
29	29 200 (4 230)	46 (115)	51 (124)	57 (134)	62 (144)	67 (153)	73 (163)	73 (163)	

Table E.3 (continued)

1	2	3	4	5	6	7	8
Time	Pressure	Temperature gradient, °C/100 m depth (°F/100 ft depth)					
		1,6 (0,9)	2,0 (1,1)	2,4 (1,3)	2,7 (1,5)	3,1 (1,7)	3,5 (1,9)
		Temperature					
min	kPa (psi)	°C (°F)	°C (°F)	°C (°F)	°C (°F)	°C (°F)	°C (°F)
		Depth: 1 830 m (6 000 ft)			Mud density: 1,22 kg/l (10,2 lbm/gal)		
30	29 600 (4 300)	46 (115)	51 (124)	57 (134)	62 (144)	67 (153)	73 (163)
31	30 100 (4 370)	46 (115)	51 (124)	57 (134)	62 (144)	67 (153)	73 (163)
32	30 600 (4 440)	46 (115)	51 (124)	57 (134)	62 (144)	67 (153)	73 (163)
33	31 100 (4 510)	46 (115)	51 (124)	57 (134)	62 (144)	67 (153)	73 (163)
34	31 600 (4 580)	46 (115)	51 (124)	57 (134)	62 (144)	67 (153)	73 (163)
35	32 100 (4 650)	46 (115)	51 (124)	57 (134)	62 (144)	67 (153)	73 (163)
Ramp (deg/min)		1,39 (2,50)	1,74 (3,14)	2,14 (3,86)	2,54 (4,57)	2,89 (5,21)	3,29 (5,93)
Ramp time		14 min					
Temp. dwell		21 min					
Pressure rate (per min)		1 171 kPa (170 psi) for 14 min, then 486 kPa (70 psi) for 21 min					

Table E.3 (continued)

1	2	3	4	5	6	7	8		
Time	Pressure	Temperature gradient, °C/100 m depth (°F/100 ft depth)							
		1,6 (0,9)	2,0 (1,1)	2,4 (1,3)	2,7 (1,5)	3,1 (1,7)	3,5 (1,9)		
		Temperature							
min	kPa (psi)	°C (°F)	°C (°F)	°C (°F)	°C (°F)	°C (°F)	°C (°F)	°C (°F)	
Depth: 2 440 m (8 000 ft)				Mud density: 1,29 kg/l (10,8 lbm/gal)					
0	6 900 (1 000)	27 (80)	27 (80)	27 (80)	27 (80)	27 (80)	27 (80)	27 (80)	
1	8 200 (1 185)	28 (83)	28 (83)	29 (84)	29 (85)	29 (85)	30 (86)	30 (86)	
2	9 400 (1 370)	29 (85)	31 (87)	31 (88)	32 (89)	33 (91)	33 (92)	33 (92)	
3	10 700 (1 555)	31 (88)	32 (90)	33 (92)	34 (94)	36 (96)	37 (98)	37 (98)	
4	12 000 (1 740)	33 (91)	34 (93)	36 (96)	37 (99)	38 (101)	40 (104)	40 (104)	
5	13 300 (1 925)	34 (93)	36 (97)	38 (100)	39 (103)	42 (107)	44 (111)	44 (111)	
6	14 500 (2 110)	36 (96)	38 (100)	40 (104)	42 (108)	44 (112)	47 (117)	47 (117)	
7	15 800 (2 295)	37 (98)	39 (103)	42 (108)	45 (113)	48 (118)	51 (123)	51 (123)	
8	17 100 (2 480)	38 (101)	42 (107)	44 (112)	47 (117)	51 (123)	54 (129)	54 (129)	
9	18 400 (2 665)	40 (104)	43 (110)	47 (116)	50 (122)	53 (128)	57 (135)	57 (135)	
10	19 700 (2 850)	41 (106)	45 (113)	49 (120)	53 (127)	57 (134)	61 (141)	61 (141)	
11	20 900 (3 035)	43 (109)	47 (117)	51 (124)	56 (131)	59 (139)	64 (147)	64 (147)	
12	22 200 (3 220)	44 (112)	49 (120)	53 (128)	58 (136)	62 (144)	67 (153)	67 (153)	
13	23 500 (3 405)	46 (114)	51 (123)	56 (132)	61 (141)	66 (150)	71 (159)	71 (159)	
14	24 800 (3 590)	47 (117)	52 (126)	58 (136)	63 (146)	68 (155)	74 (165)	74 (165)	
15	26 000 (3 775)	48 (119)	54 (130)	60 (140)	66 (150)	72 (161)	78 (172)	78 (172)	
16	27 300 (3 960)	50 (122)	56 (133)	62 (144)	68 (155)	74 (166)	81 (178)	81 (178)	
17	28 600 (4 145)	52 (125)	58 (136)	64 (148)	71 (160)	77 (171)	84 (184)	84 (184)	
18	29 900 (4 330)	53 (127)	60 (140)	67 (152)	73 (164)	81 (177)	88 (190)	88 (190)	
19	31 100 (4 515)	54 (130)	62 (143)	69 (156)	76 (169)	83 (182)	91 (196)	91 (196)	
20	31 700 (4 600)	54 (130)	62 (143)	69 (156)	76 (169)	83 (182)	91 (196)	91 (196)	
21	32 300 (4 685)	54 (130)	62 (143)	69 (156)	76 (169)	83 (182)	91 (196)	91 (196)	
22	32 900 (4 770)	54 (130)	62 (143)	69 (156)	76 (169)	83 (182)	91 (196)	91 (196)	
23	33 500 (4 855)	54 (130)	62 (143)	69 (156)	76 (169)	83 (182)	91 (196)	91 (196)	
24	34 100 (4 940)	54 (130)	62 (143)	69 (156)	76 (169)	83 (182)	91 (196)	91 (196)	
25	34 600 (5 025)	54 (130)	62 (143)	69 (156)	76 (169)	83 (182)	91 (196)	91 (196)	
26	35 200 (5 110)	54 (130)	62 (143)	69 (156)	76 (169)	83 (182)	91 (196)	91 (196)	
27	35 800 (5 195)	54 (130)	62 (143)	69 (156)	76 (169)	83 (182)	91 (196)	91 (196)	
28	36 400 (5 280)	54 (130)	62 (143)	69 (156)	76 (169)	83 (182)	91 (196)	91 (196)	
29	37 000 (5 365)	54 (130)	62 (143)	69 (156)	76 (169)	83 (182)	91 (196)	91 (196)	
30	37 600 (5 450)	54 (130)	62 (143)	69 (156)	76 (169)	83 (182)	91 (196)	91 (196)	
31	38 200 (5 535)	54 (130)	62 (143)	69 (156)	76 (169)	83 (182)	91 (196)	91 (196)	
32	38 700 (5 620)	54 (130)	62 (143)	69 (156)	76 (169)	83 (182)	91 (196)	91 (196)	
33	39 300 (5 705)	54 (130)	62 (143)	69 (156)	76 (169)	83 (182)	91 (196)	91 (196)	
34	39 900 (5 790)	54 (130)	62 (143)	69 (156)	76 (169)	83 (182)	91 (196)	91 (196)	

Table E.3 (continued)

1	2	3	4	5	6	7	8		
Time	Pressure	Temperature gradient, °C/100 m depth (°F/100 ft depth)							
		1,6 (0,9)	2,0 (1,1)	2,4 (1,3)	2,7 (1,5)	3,1 (1,7)	3,5 (1,9)		
		Temperature							
min	kPa (psi)	°C (°F)	°C (°F)	°C (°F)	°C (°F)	°C (°F)	°C (°F)	°C (°F)	
		Depth: 2 440 m (8 000 ft)				Mud density: 1,29 kg/l (10,8 lbm/gal)			
35	40 500 (5 875)	54 (130)	62 (143)	69 (156)	76 (169)	83 (182)	91 (196)		
36	41 100 (5 960)	54 (130)	62 (143)	69 (156)	76 (169)	83 (182)	91 (196)		
37	41 700 (6 045)	54 (130)	62 (143)	69 (156)	76 (169)	83 (182)	91 (196)		
38	42 300 (6 130)	54 (130)	62 (143)	69 (156)	76 (169)	83 (182)	91 (196)		
39	42 900 (6 215)	54 (130)	62 (143)	69 (156)	76 (169)	83 (182)	91 (196)		
40	43 400 (6 300)	54 (130)	62 (143)	69 (156)	76 (169)	83 (182)	91 (196)		
Ramp (deg/min)		1,46 (2,63)	1,84 (3,32)	2,22 (4,00)	2,60 (4,68)	2,98 (5,37)	3,39 (6,11)		
Ramp time		19 min							
Temp. dwell		21 min							
Pressure rate (per min)		1 274 kPa (185 psi) for 19 min, then 586 kPa (85 psi) for 21 min							



Table E.3 (continued)

1	2	3	4	5	6	7	8
Time	Pressure	Temperature gradient, °C/100 m depth (°F/100 ft depth)					
		1,6 (0,9)	2,0 (1,1)	2,4 (1,3)	2,7 (1,5)	3,1 (1,7)	3,5 (1,9)
		Temperature					
min	kPa (psi)	°C (°F)	°C (°F)	°C (°F)	°C (°F)	°C (°F)	°C (°F)
Depth: 3 050 m (10 000 ft)				Mud density: 1,38 kg/l (11,5 lbm/gal)			
0	9 000 (1 300)	27 (80)	27 (80)	27 (80)	27 (80)	27 (80)	27 (80)
1	10 300 (1 500)	28 (83)	28 (83)	29 (84)	29 (85)	30 (86)	30 (86)
2	11 700 (1 700)	30 (86)	31 (87)	31 (88)	32 (90)	33 (91)	33 (92)
3	13 100 (1 900)	31 (88)	32 (90)	33 (92)	35 (95)	36 (97)	37 (99)
4	14 500 (2 100)	33 (91)	34 (94)	36 (97)	37 (99)	39 (102)	41 (105)
5	15 900 (2 300)	34 (94)	36 (97)	38 (101)	40 (104)	42 (108)	44 (111)
6	17 200 (2 500)	36 (97)	38 (101)	41 (105)	43 (109)	45 (113)	47 (117)
7	18 600 (2 700)	37 (99)	40 (104)	43 (109)	46 (114)	48 (119)	51 (123)
8	20 000 (2 900)	39 (102)	42 (108)	45 (113)	48 (119)	51 (124)	54 (130)
9	21 400 (3 100)	41 (105)	44 (111)	47 (117)	51 (123)	54 (130)	58 (136)
10	22 800 (3 300)	42 (108)	46 (115)	49 (121)	53 (128)	57 (135)	61 (142)
11	24 100 (3 500)	43 (110)	48 (118)	52 (125)	56 (133)	61 (141)	64 (148)
12	25 500 (3 700)	45 (113)	50 (122)	54 (130)	59 (138)	64 (146)	68 (155)
13	26 900 (3 900)	47 (116)	52 (125)	57 (134)	62 (143)	67 (152)	72 (161)
14	28 300 (4 100)	48 (119)	53 (128)	59 (138)	64 (148)	70 (158)	75 (167)
15	29 600 (4 300)	49 (121)	56 (132)	61 (142)	67 (152)	73 (163)	78 (173)
16	31 000 (4 500)	51 (124)	57 (135)	63 (146)	69 (157)	76 (169)	82 (179)
17	32 400 (4 700)	53 (127)	59 (139)	66 (150)	72 (162)	79 (174)	86 (186)
18	33 800 (4 900)	54 (130)	61 (142)	68 (154)	75 (167)	82 (180)	89 (192)
19	35 200 (5 100)	56 (132)	63 (146)	70 (158)	78 (172)	85 (185)	92 (198)
20	36 500 (5 300)	57 (135)	65 (149)	73 (163)	81 (177)	88 (191)	96 (204)
21	37 900 (5 500)	59 (138)	67 (153)	75 (167)	83 (181)	91 (196)	99 (210)
22	39 300 (5 700)	61 (141)	69 (156)	77 (171)	86 (186)	94 (202)	103 (217)
23	40 700 (5 900)	62 (143)	71 (160)	79 (175)	88 (191)	97 (207)	106 (223)
24	42 100 (6 100)	63 (146)	73 (163)	82 (179)	91 (196)	101 (213)	109 (229)
25	42 700 (6 195)	63 (146)	73 (163)	82 (179)	91 (196)	101 (213)	109 (229)
26	43 400 (6 290)	63 (146)	73 (163)	82 (179)	91 (196)	101 (213)	109 (229)
27	44 000 (6 385)	63 (146)	73 (163)	82 (179)	91 (196)	101 (213)	109 (229)
28	44 700 (6 480)	63 (146)	73 (163)	82 (179)	91 (196)	101 (213)	109 (229)
29	45 300 (6 575)	63 (146)	73 (163)	82 (179)	91 (196)	101 (213)	109 (229)
30	46 000 (6 670)	63 (146)	73 (163)	82 (179)	91 (196)	101 (213)	109 (229)
31	46 600 (6 765)	63 (146)	73 (163)	82 (179)	91 (196)	101 (213)	109 (229)
32	47 300 (6 860)	63 (146)	73 (163)	82 (179)	91 (196)	101 (213)	109 (229)
33	48 000 (6 955)	63 (146)	73 (163)	82 (179)	91 (196)	101 (213)	109 (229)
34	48 600 (7 050)	63 (146)	73 (163)	82 (179)	91 (196)	101 (213)	109 (229)

Table E.3 (continued)

1	2	3	4	5	6	7	8
Time	Pressure	Temperature gradient, °C/100 m depth (°F/100 ft depth)					
		1,6 (0,9)	2,0 (1,1)	2,4 (1,3)	2,7 (1,5)	3,1 (1,7)	3,5 (1,9)
		Temperature					
min	kPa (psi)	°C (°F)	°C (°F)	°C (°F)	°C (°F)	°C (°F)	°C (°F)
		Depth: 3 050 m (10 000 ft)			Mud density: 1,38 kg/l (11,5 lbm/gal)		
35	49 300 (7 145)	63 (146)	73 (163)	82 (179)	91 (196)	101 (213)	109 (229)
36	49 900 (7 240)	63 (146)	73 (163)	82 (179)	91 (196)	101 (213)	109 (229)
37	50 600 (7 335)	63 (146)	73 (163)	82 (179)	91 (196)	101 (213)	109 (229)
38	51 200 (7 430)	63 (146)	73 (163)	82 (179)	91 (196)	101 (213)	109 (229)
39	51 900 (7 525)	63 (146)	73 (163)	82 (179)	91 (196)	101 (213)	109 (229)
40	52 500 (7 620)	63 (146)	73 (163)	82 (179)	91 (196)	101 (213)	109 (229)
41	53 200 (7 715)	63 (146)	73 (163)	82 (179)	91 (196)	101 (213)	109 (229)
42	53 800 (7 810)	63 (146)	73 (163)	82 (179)	91 (196)	101 (213)	109 (229)
43	54 500 (7 905)	63 (146)	73 (163)	82 (179)	91 (196)	101 (213)	109 (229)
44	55 200 (8 000)	63 (146)	73 (163)	82 (179)	91 (196)	101 (213)	109 (229)
45	55 800 (8 095)	63 (146)	73 (163)	82 (179)	91 (196)	101 (213)	109 (229)
Ramp (deg/min)		1,53 (2,75)	1,92 (3,46)	2,29 (4,13)	2,68 (4,83)	3,08 (5,54)	3,45 (6,21)
Ramp time		24 min					
Temp. dwell		21 min					
Pressure rate (per min)		1 379 kPa (200 psi) for 24 min, then 652 kPa (95 psi) for 21 min					

Table E.3 (continued)

1	2	3	4	5	6	7	8		
Time	Pressure	Temperature gradient, °C/100 m depth (°F/100 ft depth)							
		1,6 (0,9)	2,0 (1,1)	2,4 (1,3)	2,7 (1,5)	3,1 (1,7)	3,5 (1,9)		
		Temperature							
min	kPa (psi)	°C (°F)	°C (°F)	°C (°F)	°C (°F)	°C (°F)	°C (°F)	°C (°F)	
Depth: 3 660 m (12 000 ft)				Mud density: 1,49 kg/l (12,4 lbm/gal)					
0	10 300 (1 500)	27 (80)	27 (80)	27 (80)	27 (80)	27 (80)	27 (80)	27 (80)	
1	11 900 (1 720)	28 (83)	29 (84)	29 (84)	29 (85)	30 (86)	30 (86)	30 (86)	
2	13 400 (1 940)	30 (86)	31 (87)	31 (88)	32 (90)	33 (91)	34 (93)	34 (93)	
3	14 900 (2 160)	31 (88)	33 (91)	34 (93)	35 (95)	36 (97)	37 (99)	37 (99)	
4	16 400 (2 380)	33 (91)	34 (94)	36 (97)	38 (100)	39 (103)	41 (105)	41 (105)	
5	17 900 (2 600)	34 (94)	37 (98)	38 (101)	41 (105)	42 (108)	44 (112)	44 (112)	
6	19 400 (2 820)	36 (97)	38 (101)	41 (105)	43 (110)	46 (114)	48 (118)	48 (118)	
7	21 000 (3 040)	38 (100)	41 (105)	43 (110)	46 (115)	49 (120)	51 (124)	51 (124)	
8	22 500 (3 260)	39 (103)	42 (108)	46 (114)	48 (119)	52 (125)	55 (131)	55 (131)	
9	24 000 (3 480)	41 (105)	44 (112)	48 (118)	51 (124)	55 (131)	58 (137)	58 (137)	
10	25 500 (3 700)	42 (108)	47 (116)	50 (122)	54 (129)	58 (137)	62 (143)	62 (143)	
11	27 000 (3 920)	44 (111)	48 (119)	53 (127)	57 (134)	61 (142)	66 (150)	66 (150)	
12	28 500 (4 140)	46 (114)	51 (123)	55 (131)	59 (139)	64 (148)	69 (156)	69 (156)	
13	30 100 (4 360)	47 (117)	52 (126)	57 (135)	62 (144)	68 (154)	72 (162)	72 (162)	
14	31 600 (4 580)	49 (120)	54 (130)	59 (139)	65 (149)	71 (159)	76 (169)	76 (169)	
15	33 100 (4 800)	50 (122)	56 (133)	62 (144)	68 (154)	74 (165)	79 (175)	79 (175)	
16	34 600 (5 020)	52 (125)	58 (137)	64 (148)	71 (159)	77 (170)	83 (182)	83 (182)	
17	36 100 (5 240)	53 (128)	60 (140)	67 (152)	73 (164)	80 (176)	87 (188)	87 (188)	
18	37 600 (5 460)	55 (131)	62 (144)	69 (156)	76 (169)	83 (182)	90 (194)	90 (194)	
19	39 200 (5 680)	57 (134)	64 (147)	72 (161)	79 (174)	86 (187)	94 (201)	94 (201)	
20	40 700 (5 900)	58 (137)	66 (151)	74 (165)	82 (179)	89 (193)	97 (207)	97 (207)	
21	42 200 (6 120)	59 (139)	68 (155)	76 (169)	84 (184)	93 (199)	101 (213)	101 (213)	
22	43 700 (6 340)	61 (142)	70 (158)	78 (173)	87 (188)	96 (204)	104 (220)	104 (220)	
23	45 200 (6 560)	63 (145)	72 (162)	81 (178)	89 (193)	99 (210)	108 (226)	108 (226)	
24	46 700 (6 780)	64 (148)	74 (165)	83 (182)	92 (198)	102 (216)	111 (232)	111 (232)	
25	48 300 (7 000)	66 (151)	76 (169)	86 (186)	95 (203)	105 (221)	115 (239)	115 (239)	
26	49 800 (7 220)	68 (154)	78 (172)	88 (190)	98 (208)	108 (227)	118 (245)	118 (245)	
27	51 300 (7 440)	69 (156)	80 (176)	91 (195)	101 (213)	112 (233)	122 (251)	122 (251)	
28	52 800 (7 660)	71 (159)	82 (179)	93 (199)	103 (218)	114 (238)	126 (258)	126 (258)	
29	54 300 (7 880)	72 (162)	84 (183)	95 (203)	106 (223)	118 (244)	129 (264)	129 (264)	
30	55 100 (7 985)	72 (162)	84 (183)	95 (203)	106 (223)	118 (244)	129 (264)	129 (264)	
31	55 800 (8 090)	72 (162)	84 (183)	95 (203)	106 (223)	118 (244)	129 (264)	129 (264)	
32	56 500 (8 195)	72 (162)	84 (183)	95 (203)	106 (223)	118 (244)	129 (264)	129 (264)	
33	57 200 (8 300)	72 (162)	84 (183)	95 (203)	106 (223)	118 (244)	129 (264)	129 (264)	
34	58 000 (8 405)	72 (162)	84 (183)	95 (203)	106 (223)	118 (244)	129 (264)	129 (264)	

Table E.3 (continued)

1	2	3	4	5	6	7	8
Time	Pressure	Temperature gradient, °C/100 m depth (°F/100 ft depth)					
		1,6 (0,9)	2,0 (1,1)	2,4 (1,3)	2,7 (1,5)	3,1 (1,7)	3,5 (1,9)
		Temperature					
min	kPa (psi)	°C (°F)	°C (°F)	°C (°F)	°C (°F)	°C (°F)	°C (°F)
		Depth: 3 660 m (12 000 ft)			Mud density: 1,49 kg/l (12,4 lbm/gal)		
35	58 700 (8 510)	72 (162)	84 (183)	95 (203)	106 (223)	118 (244)	129 (264)
36	59 400 (8 615)	72 (162)	84 (183)	95 (203)	106 (223)	118 (244)	129 (264)
37	60 100 (8 720)	72 (162)	84 (183)	95 (203)	106 (223)	118 (244)	129 (264)
38	60 800 (8 825)	72 (162)	84 (183)	95 (203)	106 (223)	118 (244)	129 (264)
39	61 600 (8 930)	72 (162)	84 (183)	95 (203)	106 (223)	118 (244)	129 (264)
40	62 300 (9 035)	72 (162)	84 (183)	95 (203)	106 (223)	118 (244)	129 (264)
41	63 000 (9 140)	72 (162)	84 (183)	95 (203)	106 (223)	118 (244)	129 (264)
42	63 700 (9 245)	72 (162)	84 (183)	95 (203)	106 (223)	118 (244)	129 (264)
43	64 500 (9 350)	72 (162)	84 (183)	95 (203)	106 (223)	118 (244)	129 (264)
44	65 200 (9 455)	72 (162)	84 (183)	95 (203)	106 (223)	118 (244)	129 (264)
45	65 900 (9 560)	72 (162)	84 (183)	95 (203)	106 (223)	118 (244)	129 (264)
46	66 600 (9 665)	72 (162)	84 (183)	95 (203)	106 (223)	118 (244)	129 (264)
47	67 400 (9 770)	72 (162)	84 (183)	95 (203)	106 (223)	118 (244)	129 (264)
48	68 100 (9 875)	72 (162)	84 (183)	95 (203)	106 (223)	118 (244)	129 (264)
49	68 800 (9 980)	72 (162)	84 (183)	95 (203)	106 (223)	118 (244)	129 (264)
50	69 500 (10 085)	72 (162)	84 (183)	95 (203)	106 (223)	118 (244)	129 (264)
Ramp (deg/min)		1,57 (2,83)	1,97 (3,55)	2,36 (4,24)	2,74 (4,93)	3,14 (5,66)	3,52 (6,34)
Ramp time		29 min					
Temp. dwell		21 min					
Pressure rate (per min)		1 517 kPa (220 psi) for 29 min, then 724 kPa (105 psi) for 21 min					

Table E.3 (continued)

1	2	3	4	5	6	7	8		
Time	Pressure	Temperature gradient, °C/100 m depth (°F/100 ft depth)							
		1,6 (0,9)	2,0 (1,1)	2,4 (1,3)	2,7 (1,5)	3,1 (1,7)	3,5 (1,9)		
		Temperature							
min	kPa (psi)	°C (°F)	°C (°F)	°C (°F)	°C (°F)	°C (°F)	°C (°F)	°C (°F)	
		Depth: 4 270 m (14 000 ft)				Mud density: 1,59 kg/l (13,3 lbm/gal)			
0	12 400 (1 800)	27 (80)	27 (80)	27 (80)	27 (80)	27 (80)	27 (80)	27 (80)	
1	14 000 (2 035)	28 (83)	29 (84)	29 (84)	29 (85)	30 (86)	30 (86)	30 (86)	
2	15 700 (2 270)	30 (86)	31 (87)	32 (89)	32 (90)	33 (92)	34 (93)	34 (93)	
3	17 300 (2 505)	32 (89)	33 (91)	34 (93)	35 (95)	36 (97)	37 (99)	37 (99)	
4	18 900 (2 740)	33 (92)	35 (95)	36 (97)	38 (100)	39 (103)	41 (106)	41 (106)	
5	20 500 (2 975)	35 (95)	37 (98)	39 (102)	41 (105)	43 (109)	44 (112)	44 (112)	
6	22 100 (3 210)	36 (97)	39 (102)	41 (106)	43 (110)	46 (115)	48 (119)	48 (119)	
7	23 800 (3 445)	38 (100)	41 (106)	43 (110)	46 (115)	49 (120)	52 (125)	52 (125)	
8	25 400 (3 680)	39 (103)	43 (109)	46 (115)	49 (120)	52 (126)	56 (132)	56 (132)	
9	27 000 (3 915)	41 (106)	45 (113)	48 (119)	52 (126)	56 (132)	59 (138)	59 (138)	
10	28 600 (4 150)	43 (109)	47 (116)	51 (124)	55 (131)	59 (138)	63 (145)	63 (145)	
11	30 200 (4 385)	44 (112)	49 (120)	53 (128)	58 (136)	62 (143)	66 (151)	66 (151)	
12	31 900 (4 620)	46 (115)	51 (124)	56 (132)	61 (141)	65 (149)	70 (158)	70 (158)	
13	33 500 (4 855)	48 (118)	53 (127)	58 (137)	63 (146)	68 (155)	73 (164)	73 (164)	
14	35 100 (5 090)	49 (121)	55 (131)	61 (141)	66 (151)	72 (161)	77 (171)	77 (171)	
15	36 700 (5 325)	51 (124)	57 (135)	63 (145)	69 (156)	74 (166)	81 (177)	81 (177)	
16	38 300 (5 560)	53 (127)	59 (138)	66 (150)	72 (161)	78 (172)	84 (184)	84 (184)	
17	40 000 (5 795)	54 (130)	61 (142)	68 (154)	74 (166)	81 (178)	88 (190)	88 (190)	
18	41 600 (6 030)	56 (132)	63 (146)	70 (158)	77 (171)	84 (184)	91 (196)	91 (196)	
19	43 200 (6 265)	57 (135)	65 (149)	73 (163)	80 (176)	88 (190)	95 (203)	95 (203)	
20	44 800 (6 500)	59 (138)	67 (153)	75 (167)	83 (181)	91 (195)	98 (209)	98 (209)	
21	46 400 (6 735)	61 (141)	69 (157)	77 (171)	86 (186)	94 (201)	102 (216)	102 (216)	
22	48 100 (6 970)	62 (144)	71 (160)	80 (176)	88 (191)	97 (207)	106 (222)	106 (222)	
23	49 700 (7 205)	64 (147)	73 (164)	82 (180)	91 (196)	101 (213)	109 (229)	109 (229)	
24	51 300 (7 440)	66 (150)	76 (168)	84 (184)	94 (201)	103 (218)	113 (235)	113 (235)	
25	52 900 (7 675)	67 (153)	77 (171)	87 (189)	97 (206)	107 (224)	117 (242)	117 (242)	
26	54 500 (7 910)	69 (156)	79 (175)	89 (193)	100 (212)	110 (230)	120 (248)	120 (248)	
27	56 200 (8 145)	71 (159)	81 (178)	92 (198)	103 (217)	113 (236)	124 (255)	124 (255)	
28	57 800 (8 380)	72 (162)	83 (182)	94 (202)	106 (222)	116 (241)	127 (261)	127 (261)	
29	59 400 (8 615)	73 (164)	86 (186)	97 (206)	108 (227)	119 (247)	131 (268)	131 (268)	
30	61 000 (8 850)	75 (167)	87 (189)	99 (211)	111 (232)	123 (253)	134 (274)	134 (274)	
31	62 600 (9 085)	77 (170)	89 (193)	102 (215)	114 (237)	126 (259)	138 (281)	138 (281)	
32	64 300 (9 320)	78 (173)	92 (197)	104 (219)	117 (242)	129 (264)	142 (287)	142 (287)	
33	65 900 (9 555)	80 (176)	93 (200)	107 (224)	119 (247)	132 (270)	146 (294)	146 (294)	
34	67 500 (9 790)	82 (179)	96 (204)	109 (228)	122 (252)	136 (276)	149 (300)	149 (300)	

Table E.3 (continued)

1	2	3	4	5	6	7	8
Time	Pressure	Temperature gradient, °C/100 m depth (°F/100 ft depth)					
		1,6 (0,9)	2,0 (1,1)	2,4 (1,3)	2,7 (1,5)	3,1 (1,7)	3,5 (1,9)
		Temperature					
min	kPa (psi)	°C (°F)	°C (°F)	°C (°F)	°C (°F)	°C (°F)	°C (°F)
		Depth: 4 270 m (14 000 ft)			Mud density: 1,59 kg/l (13,3 lbm/gal)		
35	68 200 (9 895)	82 (179)	96 (204)	109 (228)	122 (252)	136 (276)	149 (300)
36	69 000 (10 000)	82 (179)	96 (204)	109 (228)	122 (252)	136 (276)	149 (300)
37	69 700 (10 105)	82 (179)	96 (204)	109 (228)	122 (252)	136 (276)	149 (300)
38	70 400 (10 210)	82 (179)	96 (204)	109 (228)	122 (252)	136 (276)	149 (300)
39	71 100 (10 315)	82 (179)	96 (204)	109 (228)	122 (252)	136 (276)	149 (300)
40	71 800 (10 420)	82 (179)	96 (204)	109 (228)	122 (252)	136 (276)	149 (300)
41	72 600 (10 525)	82 (179)	96 (204)	109 (228)	122 (252)	136 (276)	149 (300)
42	73 300 (10 630)	82 (179)	96 (204)	109 (228)	122 (252)	136 (276)	149 (300)
43	74 000 (10 735)	82 (179)	96 (204)	109 (228)	122 (252)	136 (276)	149 (300)
44	74 700 (10 840)	82 (179)	96 (204)	109 (228)	122 (252)	136 (276)	149 (300)
45	75 500 (10 945)	82 (179)	96 (204)	109 (228)	122 (252)	136 (276)	149 (300)
46	76 200 (11 050)	82 (179)	96 (204)	109 (228)	122 (252)	136 (276)	149 (300)
47	76 900 (11 155)	82 (179)	96 (204)	109 (228)	122 (252)	136 (276)	149 (300)
48	77 600 (11 260)	82 (179)	96 (204)	109 (228)	122 (252)	136 (276)	149 (300)
49	78 400 (11 365)	82 (179)	96 (204)	109 (228)	122 (252)	136 (276)	149 (300)
50	79 100 (11 470)	82 (179)	96 (204)	109 (228)	122 (252)	136 (276)	149 (300)
51	79 800 (11 575)	82 (179)	96 (204)	109 (228)	122 (252)	136 (276)	149 (300)
52	80 500 (11 680)	82 (179)	96 (204)	109 (228)	122 (252)	136 (276)	149 (300)
53	81 300 (11 785)	82 (179)	96 (204)	109 (228)	122 (252)	136 (276)	149 (300)
54	82 000 (11 890)	82 (179)	96 (204)	109 (228)	122 (252)	136 (276)	149 (300)
55	82 700 (11 995)	82 (179)	96 (204)	109 (228)	122 (252)	136 (276)	149 (300)
Ramp (deg/min)		1,62 (2,91)	2,03 (3,65)	2,42 (4,35)	2,81 (5,06)	3,2 (5,76)	3,59 (6,47)
Ramp time		34 min					
Temp. dwell		21 min					
Pressure rate (per min)		1 621 kPa (235 psi) for 34 min, then 724 kPa (105 psi) for 21 min					

Table E.3 (continued)

1	2	3	4	5	6	7	8
Time	Pressure	Temperature gradient, °C/100 m depth (°F/100 ft depth)					
		1,6 (0,9)	2,0 (1,1)	2,4 (1,3)	2,7 (1,5)	3,1 (1,7)	3,5 (1,9)
		Temperature					
min	kPa (psi)	°C (°F)	°C (°F)	°C (°F)	°C (°F)	°C (°F)	°C (°F)
Depth: 4 880 m (16 000 ft)			Mud density: 1,73 kg/l (14,4 lbm/gal)				
0	13 800 (2 000)	27 (80)	27 (80)	27 (80)	27 (80)	27 (80)	27 (80)
1	15 500 (2 255)	28 (83)	29 (84)	29 (84)	29 (85)	30 (86)	31 (87)
2	17 300 (2 510)	30 (86)	31 (87)	32 (89)	32 (90)	33 (92)	34 (93)
3	19 100 (2 765)	32 (89)	33 (91)	34 (93)	35 (95)	37 (98)	38 (100)
4	20 800 (3 020)	33 (92)	35 (95)	37 (98)	38 (101)	39 (103)	41 (106)
5	22 600 (3 275)	35 (95)	37 (99)	39 (102)	41 (106)	43 (109)	45 (113)
6	24 300 (3 530)	37 (98)	39 (102)	42 (107)	44 (111)	46 (115)	49 (120)
7	26 100 (3 785)	38 (101)	41 (106)	44 (111)	47 (116)	49 (121)	52 (126)
8	27 900 (4 040)	40 (104)	43 (110)	46 (115)	49 (121)	53 (127)	56 (133)
9	29 600 (4 295)	42 (107)	45 (113)	49 (120)	52 (126)	56 (133)	60 (140)
10	31 400 (4 550)	43 (110)	47 (117)	51 (124)	56 (132)	59 (139)	63 (146)
11	33 100 (4 805)	45 (113)	49 (121)	54 (129)	58 (137)	63 (145)	67 (153)
12	34 900 (5 060)	47 (116)	52 (125)	56 (133)	61 (142)	66 (150)	71 (159)
13	36 600 (5 315)	48 (119)	53 (128)	59 (138)	64 (147)	69 (156)	74 (166)
14	38 400 (5 570)	50 (122)	56 (132)	61 (142)	67 (152)	72 (162)	78 (173)
15	40 200 (5 825)	52 (125)	58 (136)	64 (147)	69 (157)	76 (168)	82 (179)
16	41 900 (6 080)	53 (128)	59 (139)	66 (151)	72 (162)	79 (174)	86 (186)
17	43 700 (6 335)	55 (131)	62 (143)	68 (155)	76 (168)	82 (180)	89 (192)
18	45 400 (6 590)	57 (134)	64 (147)	71 (160)	78 (173)	86 (186)	93 (199)
19	47 200 (6 845)	58 (137)	66 (151)	73 (164)	81 (178)	89 (192)	97 (206)
20	49 000 (7 100)	60 (140)	68 (154)	76 (169)	84 (183)	92 (197)	100 (212)
21	50 700 (7 355)	62 (143)	70 (158)	78 (173)	87 (188)	95 (203)	104 (219)
22	52 500 (7 610)	63 (146)	72 (162)	81 (178)	89 (193)	98 (209)	108 (226)
23	54 200 (7 865)	65 (149)	74 (166)	83 (182)	93 (199)	102 (215)	111 (232)
24	56 000 (8 120)	67 (152)	76 (169)	86 (186)	96 (204)	105 (221)	115 (239)
25	57 700 (8 375)	68 (155)	78 (173)	88 (191)	98 (209)	108 (227)	118 (245)
26	59 500 (8 530)	70 (158)	81 (177)	91 (195)	101 (214)	112 (233)	122 (252)
27	61 300 (8 885)	72 (161)	82 (180)	93 (200)	104 (219)	115 (239)	126 (259)
28	63 000 (9 140)	73 (164)	84 (184)	96 (204)	107 (224)	118 (244)	129 (265)
29	64 800 (9 395)	75 (167)	87 (188)	98 (209)	109 (229)	121 (250)	133 (272)
30	66 500 (9 650)	77 (170)	89 (192)	101 (213)	113 (235)	124 (256)	137 (278)
31	68 300 (9 905)	78 (173)	91 (195)	103 (218)	116 (240)	128 (262)	141 (285)
32	70 100 (10 160)	80 (176)	93 (199)	106 (222)	118 (245)	131 (268)	144 (292)
33	71 800 (10 415)	82 (179)	95 (203)	108 (226)	121 (250)	134 (274)	148 (298)
34	73 600 (10 670)	83 (182)	97 (206)	111 (231)	124 (255)	138 (280)	152 (305)

Table E.3 (continued)

1	2	3	4	5	6	7	8
Time	Pressure	Temperature gradient, °C/100 m depth (°F/100 ft depth)					
		1,6 (0,9)	2,0 (1,1)	2,4 (1,3)	2,7 (1,5)	3,1 (1,7)	3,5 (1,9)
min	kPa (psi)	Temperature					
		°C (°F)	°C (°F)	°C (°F)	°C (°F)	°C (°F)	°C (°F)
		Depth: 4 880 m (16 000 ft)			Mud density: 1,73 kg/l (14,4 lbm/gal)		
35	75 300 (10 925)	85 (185)	99 (210)	113 (235)	127 (260)	141 (286)	156 (312)
36	77 100 (11 180)	87 (188)	101 (214)	116 (240)	130 (266)	144 (291)	159 (318)
37	78 800 (11 435)	88 (191)	103 (218)	118 (244)	133 (271)	147 (297)	163 (325)
38	80 600 (11 690)	90 (194)	105 (221)	121 (249)	136 (276)	151 (303)	166 (331)
39	82 400 (11 945)	92 (197)	107 (225)	123 (253)	138 (281)	154 (309)	170 (338)
40	83 300 (12 085)	92 (197)	107 (225)	123 (253)	138 (281)	154 (309)	170 (338)
41	84 300 (12 225)	92 (197)	107 (225)	123 (253)	138 (281)	154 (309)	170 (338)
42	85 300 (12 365)	92 (197)	107 (225)	123 (253)	138 (281)	154 (309)	170 (338)
43	86 200 (12 505)	92 (197)	107 (225)	123 (253)	138 (281)	154 (309)	170 (338)
44	87 200 (12 645)	92 (197)	107 (225)	123 (253)	138 (281)	154 (309)	170 (338)
45	88 200 (12 785)	92 (197)	107 (225)	123 (253)	138 (281)	154 (309)	170 (338)
46	89 100 (12 925)	92 (197)	107 (225)	123 (253)	138 (281)	154 (309)	170 (338)
47	90 100 (13 065)	92 (197)	107 (225)	123 (253)	138 (281)	154 (309)	170 (338)
48	91 000 (13 205)	92 (197)	107 (225)	123 (253)	138 (281)	154 (309)	170 (338)
49	92 000 (13 345)	92 (197)	107 (225)	123 (253)	138 (281)	154 (309)	170 (338)
50	93 000 (13 485)	92 (197)	107 (225)	123 (253)	138 (281)	154 (309)	170 (338)
51	93 900 (13 625)	92 (197)	107 (225)	123 (253)	138 (281)	154 (309)	170 (338)
52	94 900 (13 765)	92 (197)	107 (225)	123 (253)	138 (281)	154 (309)	170 (338)
53	95 900 (13 905)	92 (197)	107 (225)	123 (253)	138 (281)	154 (309)	170 (338)
54	96 800 (14 045)	92 (197)	107 (225)	123 (253)	138 (281)	154 (309)	170 (338)
55	97 800 (14 185)	92 (197)	107 (225)	123 (253)	138 (281)	154 (309)	170 (338)
Ramp (deg/min)		1,67 (3,00)	2,07 (3,72)	2,47 (4,44)	2,86 (5,15)	3,26 (5,87)	3,68 (6,62)
Ramp time		39 min					
Temp. dwell		16 min					
Pressure rate (per min)		1 759 kPa (255 psi) for 39 min, then 963 kPa (140 psi) for 16 min					



Table E.3 (continued)

1	2	3	4	5	6	7	8
Time	Pressure	Temperature gradient, °C/100 m depth (°F/100 ft depth)					
		1,6 (0,9)	2,0 (1,1)	2,4 (1,3)	2,7 (1,5)	3,1 (1,7)	3,5 (1,9)
min	kPa (psi)	Temperature					
		°C (°F)	°C (°F)	°C (°F)	°C (°F)	°C (°F)	°C (°F)
		Depth: 5 490 m (18 000 ft)			Mud density: 1,87 kg/l (15,6 lbm/gal)		
0	15 200 (2 200)	27 (80)	27 (80)	27 (80)	27 (80)	27 (80)	27 (80)
1	17 100 (2 475)	28 (83)	29 (84)	29 (85)	29 (85)	30 (86)	31 (87)
2	19 000 (2 750)	30 (86)	31 (88)	32 (89)	33 (91)	33 (92)	34 (93)
3	20 900 (3 025)	32 (89)	33 (91)	34 (94)	36 (96)	37 (98)	38 (100)
4	22 800 (3 300)	33 (92)	35 (95)	37 (98)	38 (101)	40 (104)	42 (107)
5	24 600 (3 575)	35 (95)	37 (99)	39 (103)	41 (106)	43 (110)	46 (114)
6	26 500 (3 850)	37 (98)	39 (103)	42 (107)	44 (112)	47 (116)	49 (120)
7	28 400 (4 125)	38 (101)	42 (107)	44 (112)	47 (117)	50 (122)	53 (127)
8	30 300 (4 400)	41 (105)	44 (111)	47 (116)	50 (122)	53 (128)	57 (134)
9	32 200 (4 675)	42 (108)	46 (114)	49 (121)	53 (127)	57 (134)	61 (141)
10	34 100 (4 950)	44 (111)	48 (118)	52 (125)	56 (133)	60 (140)	64 (147)
11	36 000 (5 225)	46 (114)	50 (122)	54 (130)	59 (138)	63 (146)	68 (154)
12	37 900 (5 500)	47 (117)	52 (126)	57 (135)	62 (143)	67 (152)	72 (161)
13	39 800 (5 775)	49 (120)	54 (130)	59 (139)	65 (149)	70 (158)	75 (167)
14	41 700 (6 050)	51 (123)	56 (133)	62 (144)	68 (154)	73 (164)	79 (174)
15	43 600 (6 325)	52 (126)	58 (137)	64 (148)	71 (159)	77 (170)	83 (181)
16	45 500 (6 600)	54 (129)	61 (141)	67 (153)	73 (164)	80 (176)	87 (188)
17	47 400 (6 875)	56 (132)	63 (145)	69 (157)	77 (170)	83 (182)	90 (194)
18	49 300 (7 150)	57 (135)	65 (149)	72 (162)	79 (175)	87 (188)	94 (201)
19	51 200 (7 425)	59 (138)	67 (153)	74 (166)	82 (180)	90 (194)	98 (208)
20	53 100 (7 700)	61 (141)	69 (156)	77 (171)	85 (185)	93 (200)	102 (215)
21	55 000 (7 975)	62 (144)	71 (160)	79 (175)	88 (191)	97 (206)	105 (221)
22	56 900 (8 250)	64 (148)	73 (164)	82 (180)	91 (196)	100 (212)	109 (228)
23	58 800 (8 525)	66 (151)	76 (168)	85 (185)	94 (201)	103 (218)	113 (235)
24	60 700 (8 800)	68 (154)	78 (172)	87 (189)	97 (207)	107 (224)	116 (241)
25	62 600 (9 075)	69 (157)	79 (175)	90 (194)	100 (212)	110 (230)	120 (248)
26	64 500 (9 350)	71 (160)	82 (179)	92 (198)	103 (217)	113 (236)	124 (255)
27	66 400 (9 625)	73 (163)	84 (183)	95 (203)	106 (222)	117 (242)	128 (262)
28	68 300 (9 900)	74 (166)	86 (187)	97 (207)	109 (228)	120 (248)	131 (268)
29	70 200 (10 175)	76 (169)	88 (191)	100 (212)	112 (233)	123 (254)	135 (275)
30	72 100 (10 450)	78 (172)	91 (195)	102 (216)	114 (238)	127 (260)	139 (282)
31	73 900 (10 725)	79 (175)	92 (198)	105 (221)	117 (243)	130 (266)	143 (289)
32	75 800 (11 000)	81 (178)	94 (202)	107 (225)	121 (249)	133 (272)	146 (295)
33	77 700 (11 275)	83 (181)	97 (206)	110 (230)	123 (254)	137 (278)	150 (302)
34	79 600 (11 550)	84 (184)	99 (210)	113 (235)	126 (259)	140 (284)	154 (309)

Table E.3 (continued)

1	2	3	4	5	6	7	8
Time	Pressure	Temperature gradient, °C/100 m depth (°F/100 ft depth)					
		1,6 (0,9)	2,0 (1,1)	2,4 (1,3)	2,7 (1,5)	3,1 (1,7)	3,5 (1,9)
min	kPa (psi)	Temperature					
		°C (°F)	°C (°F)	°C (°F)	°C (°F)	°C (°F)	°C (°F)
		Depth: 5 490 m (18 000 ft)			Mud density: 1,87 kg/l (15,6 lbm/gal)		
35	81 500 (11 825)	86 (187)	101 (214)	115 (239)	129 (265)	143 (290)	157 (315)
36	83 400 (12 100)	88 (190)	103 (217)	118 (244)	132 (270)	147 (296)	161 (322)
37	85 300 (12 375)	90 (194)	105 (221)	120 (248)	135 (275)	150 (302)	165 (329)
38	87 200 (12 650)	92 (197)	107 (225)	123 (253)	138 (280)	153 (308)	169 (336)
39	89 100 (12 925)	93 (200)	109 (229)	125 (257)	141 (286)	157 (314)	172 (342)
40	91 000 (13 200)	95 (203)	112 (233)	128 (262)	144 (291)	160 (320)	176 (349)
41	92 900 (13 475)	97 (206)	114 (237)	130 (266)	147 (296)	163 (326)	180 (356)
42	94 800 (13 750)	98 (209)	116 (240)	133 (271)	149 (301)	167 (332)	184 (363)
43	96 700 (14 025)	100 (212)	118 (244)	135 (275)	153 (307)	170 (338)	187 (369)
44	98 600 (14 300)	102 (215)	120 (248)	138 (280)	156 (312)	173 (344)	191 (376)
45	99 500 (14 435)	102 (215)	120 (248)	138 (280)	156 (312)	173 (344)	191 (376)
46	100 500 (14 570)	102 (215)	120 (248)	138 (280)	156 (312)	173 (344)	191 (376)
47	101 400 (14 705)	102 (215)	120 (248)	138 (280)	156 (312)	173 (344)	191 (376)
48	102 300 (14 840)	102 (215)	120 (248)	138 (280)	156 (312)	173 (344)	191 (376)
49	103 300 (14 975)	102 (215)	120 (248)	138 (280)	156 (312)	173 (344)	191 (376)
50	104 200 (15 110)	102 (215)	120 (248)	138 (280)	156 (312)	173 (344)	191 (376)
51	105 100 (15 245)	102 (215)	120 (248)	138 (280)	156 (312)	173 (344)	191 (376)
52	106 000 (15 380)	102 (215)	120 (248)	138 (280)	156 (312)	173 (344)	191 (376)
53	107 000 (15 515)	102 (215)	120 (248)	138 (280)	156 (312)	173 (344)	191 (376)
54	107 900 (15 650)	102 (215)	120 (248)	138 (280)	156 (312)	173 (344)	191 (376)
55	108 800 (15 785)	102 (215)	120 (248)	138 (280)	156 (312)	173 (344)	191 (376)
56	109 800 (15 920)	102 (215)	120 (248)	138 (280)	156 (312)	173 (344)	191 (376)
57	110 700 (16 055)	102 (215)	120 (248)	138 (280)	156 (312)	173 (344)	191 (376)
58	111 600 (16 190)	102 (215)	120 (248)	138 (280)	156 (312)	173 (344)	191 (376)
59	112 600 (16 325)	102 (215)	120 (248)	138 (280)	156 (312)	173 (344)	191 (376)
60	113 500 (16 460)	102 (215)	120 (248)	138 (280)	156 (312)	173 (344)	191 (376)
Ramp (deg/min)		1,71 (3,07)	2,12 (3,82)	2,53 (4,55)	2,93 (5,27)	3,33 (6,00)	3,74 (6,73)
Ramp time		44 min					
Temp. dwell		16 min					
Pressure rate (per min)		1 895 kPa (275 psi) for 44 min, then 931 kPa (135 psi) for 16 min					

Table E.3 (continued)

1	2	3	4	5	6	7	8
Time	Pressure	Temperature gradient, °C/100 m depth (°F/100 ft depth)					
		1,6 (0,9)	2,0 (1,1)	2,4 (1,3)	2,7 (1,5)	3,1 (1,7)	3,5 (1,9)
min	kPa (psi)	Temperature					
		°C (°F)	°C (°F)	°C (°F)	°C (°F)	°C (°F)	°C (°F)
		Depth: 6 095 m (20 000 ft)			Mud density: 2,03 kg/l (16,9 lbm/gal)		
0	16 500 (2 400)	27 (80)	27 (80)	27 (80)	27 (80)	27 (80)	27 (80)
1	18 600 (2 695)	28 (83)	29 (84)	29 (85)	29 (85)	30 (86)	31 (87)
2	20 600 (2 990)	30 (86)	31 (88)	32 (89)	33 (91)	33 (92)	34 (94)
3	22 700 (3 285)	32 (89)	33 (92)	34 (94)	36 (96)	37 (98)	38 (101)
4	24 700 (3 580)	34 (93)	36 (96)	37 (99)	39 (102)	40 (104)	42 (108)
5	26 700 (3 875)	36 (96)	37 (99)	39 (103)	42 (107)	44 (111)	46 (114)
6	28 800 (4 170)	37 (99)	39 (103)	42 (108)	44 (112)	47 (117)	49 (121)
7	30 800 (4 465)	39 (102)	42 (107)	44 (112)	48 (118)	51 (123)	53 (128)
8	32 800 (4 760)	41 (105)	44 (111)	47 (117)	51 (123)	54 (129)	57 (135)
9	34 900 (5 055)	42 (108)	46 (115)	50 (122)	53 (128)	57 (135)	61 (142)
10	36 900 (5 350)	44 (111)	48 (119)	52 (126)	57 (134)	61 (141)	65 (149)
11	38 900 (5 645)	46 (115)	51 (123)	55 (131)	59 (139)	64 (147)	69 (156)
12	41 000 (5 940)	48 (118)	53 (127)	58 (136)	63 (145)	67 (153)	73 (163)
13	43 000 (6 235)	49 (121)	55 (131)	60 (140)	66 (150)	71 (160)	76 (169)
14	45 000 (6 530)	51 (124)	57 (135)	63 (145)	68 (155)	74 (166)	80 (176)
15	47 100 (6 825)	53 (127)	59 (138)	65 (149)	72 (161)	78 (172)	84 (183)
16	49 100 (7 120)	54 (130)	61 (142)	68 (154)	74 (166)	81 (178)	88 (190)
17	51 100 (7 415)	56 (133)	63 (146)	71 (159)	78 (172)	84 (184)	92 (197)
18	53 200 (7 710)	58 (137)	66 (150)	73 (163)	81 (177)	88 (190)	96 (204)
19	55 200 (8 005)	60 (140)	68 (154)	76 (168)	83 (182)	91 (196)	99 (211)
20	57 200 (8 300)	62 (143)	70 (158)	78 (173)	87 (188)	94 (202)	103 (218)
21	59 300 (8 595)	63 (146)	72 (162)	81 (177)	89 (193)	98 (209)	107 (224)
22	61 300 (8 890)	65 (149)	74 (166)	83 (182)	93 (199)	102 (215)	111 (231)
23	63 300 (9 185)	67 (152)	77 (170)	86 (187)	96 (204)	105 (221)	114 (238)
24	65 400 (9 480)	68 (155)	79 (174)	88 (191)	98 (209)	108 (227)	118 (245)
25	67 400 (9 775)	71 (159)	81 (177)	91 (196)	102 (215)	112 (233)	122 (252)
26	69 400 (10 070)	72 (162)	83 (181)	93 (200)	104 (220)	115 (239)	126 (259)
27	71 500 (10 365)	74 (165)	85 (185)	96 (205)	107 (225)	118 (245)	130 (266)
28	73 500 (10 660)	76 (168)	87 (189)	99 (210)	111 (231)	122 (251)	134 (273)
29	75 500 (10 955)	77 (171)	89 (193)	101 (214)	113 (236)	126 (258)	137 (279)
30	77 600 (11 250)	79 (174)	92 (197)	104 (219)	117 (242)	129 (264)	141 (286)
31	79 600 (11 545)	81 (177)	94 (201)	107 (224)	119 (247)	132 (270)	145 (293)
32	81 600 (11 840)	83 (181)	96 (205)	109 (228)	122 (252)	136 (276)	149 (300)
33	83 700 (12 135)	84 (184)	98 (209)	112 (233)	126 (258)	139 (282)	153 (307)
34	85 700 (12 430)	86 (187)	101 (213)	114 (238)	128 (263)	142 (288)	157 (314)

Table E.3 (continued)

1	2	3	4	5	6	7	8
Time	Pressure	Temperature gradient, °C/100 m depth (°F/100 ft depth)					
		1,6 (0,9)	2,0 (1,1)	2,4 (1,3)	2,7 (1,5)	3,1 (1,7)	3,5 (1,9)
min	kPa (psi)	Temperature					
		°C (°F)	°C (°F)	°C (°F)	°C (°F)	°C (°F)	°C (°F)
		Depth: 6 095 m (20 000 ft)			Mud density: 2,03 kg/l (16,9 lbm/gal)		
35	87 700 (12 725)	88 (190)	102 (216)	117 (242)	132 (269)	146 (294)	161 (321)
36	89 800 (13 020)	89 (193)	104 (220)	119 (247)	134 (274)	149 (300)	164 (328)
37	91 800 (13 315)	91 (196)	107 (224)	122 (251)	137 (279)	153 (307)	168 (334)
38	93 800 (13 610)	93 (199)	109 (228)	124 (256)	141 (285)	156 (313)	172 (341)
39	95 900 (13 905)	95 (203)	111 (232)	127 (261)	143 (290)	159 (319)	176 (348)
40	97 900 (14 200)	97 (206)	113 (236)	129 (265)	147 (296)	163 (325)	179 (355)
41	99 900 (14 495)	98 (209)	116 (240)	132 (270)	149 (301)	166 (331)	183 (362)
42	102 000 (14 790)	100 (212)	118 (244)	135 (275)	152 (306)	169 (337)	187 (369)
43	104 000 (15 085)	102 (215)	120 (248)	137 (279)	156 (312)	173 (343)	191 (376)
44	106 000 (15 380)	103 (218)	122 (252)	140 (284)	158 (317)	176 (349)	195 (383)
45	108 100 (15 675)	105 (221)	124 (255)	142 (288)	161 (322)	180 (356)	198 (389)
46	110 100 (15 970)	107 (225)	126 (259)	145 (293)	164 (328)	183 (362)	202 (396)
47	112 100 (16 265)	109 (228)	128 (263)	148 (298)	167 (333)	187 (368)	206 (403)
48	114 200 (16 560)	111 (231)	131 (267)	150 (302)	171 (339)	190 (374)	210 (410)
49	116 200 (16 855)	112 (234)	133 (271)	153 (307)	173 (344)	193 (380)	214 (417)
50	117 400 (17 030)	112 (234)	133 (271)	153 (307)	173 (344)	193 (380)	214 (417)
51	118 600 (17 205)	112 (234)	133 (271)	153 (307)	173 (344)	193 (380)	214 (417)
52	119 800 (17 380)	112 (234)	133 (271)	153 (307)	173 (344)	193 (380)	214 (417)
53	121 000 (17 555)	112 (234)	133 (271)	153 (307)	173 (344)	193 (380)	214 (417)
54	122 200 (17 730)	112 (234)	133 (271)	153 (307)	173 (344)	193 (380)	214 (417)
55	123 500 (17 905)	112 (234)	133 (271)	153 (307)	173 (344)	193 (380)	214 (417)
56	124 700 (18 080)	112 (234)	133 (271)	153 (307)	173 (344)	193 (380)	214 (417)
57	125 900 (18 255)	112 (234)	133 (271)	153 (307)	173 (344)	193 (380)	214 (417)
58	127 100 (18 430)	112 (234)	133 (271)	153 (307)	173 (344)	193 (380)	214 (417)
59	128 300 (18 605)	112 (234)	133 (271)	153 (307)	173 (344)	193 (380)	214 (417)
60	129 500 (18 780)	112 (234)	133 (271)	153 (307)	173 (344)	193 (380)	214 (417)
Ramp (deg/min)		1,74 (3,14)	2,17 (3,90)	2,57 (4,63)	2,99 (5,39)	3,40 (6,12)	3,82 (6,88)
Ramp time		49 min					
Temp. dwell		11 min					
Pressure rate (per min)		2 035 kPa (295 psi) for 49 min, then 1 209 kPa (175 psi) for 11 min					

Table E.3 (continued)

1	2	3	4	5	6	7	8
Time	Pressure	Temperature gradient, °C/100 m depth (°F/100 ft depth)					
		1,6 (0,9)	2,0 (1,1)	2,4 (1,3)	2,7 (1,5)	3,1 (1,7)	3,5 (1,9)
min	kPa (psi)	Temperature					
		°C (°F)	°C (°F)	°C (°F)	°C (°F)	°C (°F)	°C (°F)
		Depth: 6 705 m (22 000 ft)			Mud density: 2,18 kg/l (18,2 lbm/gal)		
0	17 900 (2 600)	27 (80)	27 (80)	27 (80)	27 (80)	27 (80)	27 (80)
1	20 100 (2 910)	28 (83)	29 (84)	29 (85)	30 (86)	30 (86)	31 (87)
2	22 200 (3 220)	30 (86)	31 (88)	32 (89)	33 (91)	34 (93)	34 (94)
3	24 300 (3 530)	32 (90)	33 (92)	34 (94)	36 (97)	37 (99)	38 (101)
4	26 500 (3 840)	34 (93)	36 (96)	37 (99)	39 (102)	41 (105)	42 (108)
5	28 600 (4 150)	36 (96)	38 (100)	40 (104)	42 (108)	44 (111)	46 (115)
6	30 800 (4 460)	37 (99)	40 (104)	42 (108)	45 (113)	48 (118)	50 (122)
7	32 900 (4 770)	39 (103)	42 (108)	45 (113)	48 (119)	51 (124)	54 (129)
8	35 000 (5 080)	41 (106)	44 (112)	48 (118)	51 (124)	54 (130)	58 (136)
9	37 200 (5 390)	43 (109)	47 (116)	51 (123)	54 (130)	58 (136)	62 (143)
10	39 300 (5 700)	44 (112)	49 (120)	53 (127)	57 (135)	62 (143)	66 (150)
11	41 400 (6 010)	46 (115)	51 (124)	56 (132)	61 (141)	65 (149)	69 (157)
12	43 600 (6 320)	48 (119)	53 (128)	58 (137)	63 (146)	68 (155)	73 (164)
13	45 700 (6 630)	50 (122)	56 (132)	61 (142)	67 (152)	72 (161)	77 (171)
14	47 900 (6 940)	52 (125)	58 (136)	63 (146)	69 (157)	76 (168)	81 (178)
15	50 000 (7 250)	53 (128)	60 (140)	66 (151)	73 (163)	79 (174)	85 (185)
16	52 100 (7 560)	56 (132)	62 (144)	69 (156)	76 (168)	82 (180)	89 (192)
17	54 300 (7 870)	57 (135)	64 (148)	72 (161)	79 (174)	86 (186)	93 (199)
18	56 400 (8 180)	59 (138)	67 (152)	74 (165)	82 (179)	89 (193)	97 (206)
19	58 500 (8 490)	61 (141)	69 (156)	77 (170)	85 (185)	93 (199)	101 (213)
20	60 700 (8 800)	62 (144)	71 (160)	79 (175)	88 (190)	96 (205)	104 (220)
21	62 800 (9 110)	64 (148)	73 (164)	82 (180)	91 (196)	99 (211)	108 (227)
22	65 000 (9 420)	66 (151)	76 (168)	84 (184)	94 (201)	103 (218)	112 (234)
23	67 100 (9 730)	68 (154)	78 (172)	87 (189)	97 (207)	107 (224)	116 (241)
24	69 200 (10 040)	69 (157)	80 (176)	90 (194)	100 (212)	110 (230)	120 (248)
25	71 400 (10 350)	72 (161)	82 (180)	93 (199)	103 (218)	113 (236)	124 (255)
26	73 500 (10 660)	73 (164)	84 (184)	95 (203)	106 (223)	117 (243)	128 (262)
27	75 600 (10 970)	75 (167)	87 (188)	98 (208)	109 (229)	121 (249)	132 (270)
28	77 800 (11 280)	77 (170)	88 (191)	101 (213)	112 (234)	124 (255)	136 (277)
29	79 900 (11 590)	78 (173)	91 (195)	103 (217)	116 (240)	128 (262)	140 (284)
30	82 100 (11 900)	81 (177)	93 (199)	106 (222)	118 (245)	131 (268)	144 (291)
31	84 200 (12 210)	82 (180)	95 (203)	108 (227)	122 (251)	134 (274)	148 (298)
32	86 300 (12 520)	84 (183)	97 (207)	111 (232)	124 (256)	138 (280)	152 (305)
33	88 500 (12 830)	86 (186)	99 (211)	113 (236)	128 (262)	142 (287)	156 (312)
34	90 600 (13 140)	88 (190)	102 (215)	116 (241)	131 (267)	145 (293)	159 (319)

Table E.3 (continued)

1	2	3	4	5	6	7	8
Time	Pressure	Temperature gradient, °C/100 m depth (°F/100 ft depth)					
		1,6 (0,9)	2,0 (1,1)	2,4 (1,3)	2,7 (1,5)	3,1 (1,7)	3,5 (1,9)
		Temperature					
min	kPa (psi)	°C (°F)	°C (°F)	°C (°F)	°C (°F)	°C (°F)	°C (°F)
		Depth: 6 705 m (22 000 ft)			Mud density: 2,18 kg/l (18,2 lbm/gal)		
35	92 700 (13 450)	89 (193)	104 (219)	119 (246)	134 (273)	148 (299)	163 (326)
36	94 900 (13 760)	91 (196)	106 (223)	122 (251)	137 (278)	152 (305)	167 (333)
37	97 000 (14 070)	93 (199)	108 (227)	124 (255)	140 (284)	156 (312)	171 (340)
38	99 200 (14 380)	94 (202)	111 (231)	127 (260)	143 (289)	159 (318)	175 (347)
39	101 300 (14 690)	97 (206)	113 (235)	129 (265)	146 (295)	162 (324)	179 (354)
40	103 400 (15 000)	98 (209)	115 (239)	132 (270)	149 (300)	166 (330)	183 (361)
41	105 600 (15 310)	100 (212)	117 (243)	134 (274)	152 (306)	169 (337)	187 (368)
42	107 700 (15 620)	102 (215)	119 (247)	137 (279)	155 (311)	173 (343)	191 (375)
43	109 800 (15 930)	104 (219)	122 (251)	140 (284)	158 (317)	176 (349)	194 (382)
44	112 000 (16 240)	106 (222)	124 (255)	143 (289)	161 (322)	179 (355)	198 (389)
45	114 100 (16 550)	107 (225)	126 (259)	145 (293)	164 (328)	183 (362)	202 (396)
46	116 200 (16 860)	109 (228)	128 (263)	148 (298)	167 (333)	187 (368)	206 (403)
47	118 400 (17 170)	111 (231)	131 (267)	151 (303)	171 (339)	190 (374)	210 (410)
48	120 500 (17 480)	113 (235)	133 (271)	153 (308)	173 (344)	193 (380)	214 (417)
49	122 700 (17 790)	114 (238)	135 (275)	156 (312)	177 (350)	197 (387)	218 (424)
50	124 800 (18 100)	116 (241)	137 (279)	158 (317)	179 (355)	201 (393)	222 (431)
51	126 900 (18 410)	118 (244)	139 (283)	161 (322)	183 (361)	204 (399)	226 (438)
52	129 100 (18 720)	120 (248)	142 (287)	164 (327)	186 (366)	207 (405)	229 (445)
53	131 200 (19 030)	122 (251)	144 (291)	166 (331)	189 (372)	211 (412)	233 (452)
54	133 300 (19 340)	123 (254)	146 (295)	169 (336)	192 (377)	214 (418)	237 (459)
55	134 600 (19 515)	123 (254)	146 (295)	169 (336)	192 (377)	214 (418)	237 (459)
56	135 800 (19 690)	123 (254)	146 (295)	169 (336)	192 (377)	214 (418)	237 (459)
57	137 000 (19 865)	123 (254)	146 (295)	169 (336)	192 (377)	214 (418)	237 (459)
58	138 200 (20 040)	123 (254)	146 (295)	169 (336)	192 (377)	214 (418)	237 (459)
59	139 400 (20 215)	123 (254)	146 (295)	169 (336)	192 (377)	214 (418)	237 (459)
60	140 600 (20 390)	123 (254)	146 (295)	169 (336)	192 (377)	214 (418)	237 (459)
61	141 800 (20 565)	123 (254)	146 (295)	169 (336)	192 (377)	214 (418)	237 (459)
62	143 000 (20 740)	123 (254)	146 (295)	169 (336)	192 (377)	214 (418)	237 (459)
63	144 200 (20 915)	123 (254)	146 (295)	169 (336)	192 (377)	214 (418)	237 (459)
64	145 400 (21 090)	123 (254)	146 (295)	169 (336)	192 (377)	214 (418)	237 (459)
65	146 600 (21 265)	123 (254)	146 (295)	169 (336)	192 (377)	214 (418)	237 (459)
Ramp (deg/min)		1,79 (3,22)	2,21 (3,98)	2,63 (4,74)	3,06 (5,50)	3,48 (6,26)	3,90 (7,02)
Ramp time		54 min					
Temp. dwell		11 min					
Pressure rate (per min)		2 137 kPa (310 psi) for 54 min, then 1 209 kPa (175 psi) for 11 min					

Table E.4 — Hesitation-squeeze well-simulation tests

1	2	3	4	5	6	7	8	9									
Time min	Pressure kPa (psi)	Temperature gradient, °C/100 m depth (°F/100 ft depth)												Stirring			
		1,6 (0,9)		2,0 (1,1)		2,4 (1,3)		2,7 (1,5)		3,1 (1,7)		3,5 (1,9)					
		Temperature															
°C (°F)						°C (°F)						°C (°F)					
Depth: 305 m (1 000 ft)						Mud density: 1,10 kg/l (9,2 lbm/gal)											
0	3 400 (500)	27 (80)	27 (80)	27 (80)	27 (80)	27 (80)	27 (80)	27 (80)	27 (80)	27 (80)	27 (80)	27 (80)	27 (80)	On			
1	3 400 (500)	27 (80)	27 (80)	27 (80)	28 (82)	28 (83)	29 (85)	30 (86)	30 (86)	30 (86)	30 (86)	30 (86)	30 (86)	On			
2	3 600 (520)	27 (80)	27 (80)	27 (80)	28 (82)	28 (83)	29 (85)	30 (86)	30 (86)	30 (86)	30 (86)	30 (86)	30 (86)	On			
3	3 700 (540)	27 (80)	27 (80)	27 (80)	28 (82)	28 (83)	29 (85)	30 (86)	30 (86)	30 (86)	30 (86)	30 (86)	30 (86)	On			
4	3 900 (560)	27 (80)	27 (80)	27 (80)	28 (82)	28 (83)	29 (85)	30 (86)	30 (86)	30 (86)	30 (86)	30 (86)	30 (86)	On			
5	4 000 (580)	27 (80)	27 (80)	27 (80)	28 (82)	28 (83)	29 (85)	30 (86)	30 (86)	30 (86)	30 (86)	30 (86)	30 (86)	On			
6	4 100 (600)	27 (80)	27 (80)	27 (80)	28 (82)	28 (83)	29 (85)	30 (86)	30 (86)	30 (86)	30 (86)	30 (86)	30 (86)	On			
7	4 300 (620)	27 (80)	27 (80)	27 (80)	28 (82)	28 (83)	29 (85)	30 (86)	30 (86)	30 (86)	30 (86)	30 (86)	30 (86)	On			
8	4 400 (640)	27 (80)	27 (80)	27 (80)	28 (82)	28 (83)	29 (85)	30 (86)	30 (86)	30 (86)	30 (86)	30 (86)	30 (86)	On			
9	4 600 (660)	27 (80)	27 (80)	27 (80)	28 (82)	28 (83)	29 (85)	30 (86)	30 (86)	30 (86)	30 (86)	30 (86)	30 (86)	On			
10	4 700 (680)	27 (80)	27 (80)	27 (80)	28 (82)	28 (83)	29 (85)	30 (86)	30 (86)	30 (86)	30 (86)	30 (86)	30 (86)	On			
11	4 800 (700)	27 (80)	27 (80)	27 (80)	28 (82)	28 (83)	29 (85)	30 (86)	30 (86)	30 (86)	30 (86)	30 (86)	30 (86)	On			
12	5 000 (720)	27 (80)	27 (80)	27 (80)	28 (82)	28 (83)	29 (85)	30 (86)	30 (86)	30 (86)	30 (86)	30 (86)	30 (86)	On			
13	5 100 (740)	27 (80)	27 (80)	27 (80)	28 (82)	28 (83)	29 (85)	30 (86)	30 (86)	30 (86)	30 (86)	30 (86)	30 (86)	On			
14	5 200 (760)	27 (80)	27 (80)	27 (80)	28 (82)	28 (83)	29 (85)	30 (86)	30 (86)	30 (86)	30 (86)	30 (86)	30 (86)	On			
15	5 400 (780)	27 (80)	27 (80)	27 (80)	28 (82)	28 (83)	29 (85)	30 (86)	30 (86)	30 (86)	30 (86)	30 (86)	30 (86)	Off			
25	5 400 (780)	28 (82)	28 (82)	28 (82)	29 (84)	29 (85)	31 (87)	31 (88)	31 (88)	31 (88)	31 (88)	31 (88)	31 (88)	On			
30	5 400 (780)	28 (83)	28 (83)	28 (83)	29 (85)	30 (86)	31 (88)	32 (89)	32 (89)	32 (89)	32 (89)	32 (89)	32 (89)	Off			
40	5 400 (780)	29 (85)	29 (85)	29 (85)	31 (87)	31 (88)	32 (90)	33 (91)	33 (91)	33 (91)	33 (91)	33 (91)	33 (91)	On			
45	5 400 (780)	30 (86)	30 (86)	30 (86)	31 (88)	32 (89)	33 (91)	33 (92)	33 (92)	33 (92)	33 (92)	33 (92)	33 (92)	Off			
55	5 400 (780)	31 (88)	31 (88)	31 (88)	32 (90)	33 (91)	34 (93)	34 (94)	34 (94)	34 (94)	34 (94)	34 (94)	34 (94)	On			
60	5 400 (780)	32 (89)	32 (89)	32 (89)	33 (91)	33 (92)	34 (94)	35 (95)	35 (95)	35 (95)	35 (95)	35 (95)	35 (95)	Off			
70	5 400 (780)	32 (89)	33 (91)	33 (91)	34 (93)	34 (94)	36 (96)	36 (97)	36 (97)	36 (97)	36 (97)	36 (97)	36 (97)	On			
75	5 400 (780)	32 (89)	33 (91)	33 (91)	34 (93)	35 (95)	36 (97)	37 (98)	37 (98)	37 (98)	37 (98)	37 (98)	37 (98)	Off			
85	5 400 (780)	32 (89)	33 (91)	33 (91)	34 (93)	35 (95)	36 (97)	37 (99)	37 (99)	37 (99)	37 (99)	37 (99)	37 (99)	On			
90	5 400 (780)	32 (89)	33 (91)	33 (91)	34 (93)	35 (95)	36 (97)	37 (99)	37 (99)	37 (99)	37 (99)	37 (99)	37 (99)	Off			
100	5 400 (780)	32 (89)	33 (91)	33 (91)	34 (93)	35 (95)	36 (97)	37 (99)	37 (99)	37 (99)	37 (99)	37 (99)	37 (99)	On			
105	5 400 (780)	32 (89)	33 (91)	33 (91)	34 (93)	35 (95)	36 (97)	37 (99)	37 (99)	37 (99)	37 (99)	37 (99)	37 (99)	Off			

Table E.4 (continued)

1	2	3	4	5	6	7	8	9
Time min	Pressure kPa (psi)	Temperature gradient, °C/100 m depth (°F/100 ft depth)						Stirring
		1,6 (0,9)	2,0 (1,1)	2,4 (1,3)	2,7 (1,5)	3,1 (1,7)	3,5 (1,9)	
	Temperature							
		°C (°F)	°C (°F)	°C (°F)	°C (°F)	°C (°F)	°C (°F)	
Depth: 305 m (1 000 ft)				Mud density: 1,10 kg/l (9,2 lbm/gal)				
<b>Segment 1</b>								
Ramp (deg/min)		0,00 (0,00)	0,00 (0,00)	1,11 (2,00)	1,67 (3,00)	2,78 (5,00)	3,33 (6,00)	
Ramp time		1 min						
Temp. dwell		14 min						
Pressure rate (per min)		0 kPa (0 psi) for 1 min, then 143 kPa (20 psi) for 14 min						
<b>Segment 2</b>								
Ramp (deg/min)		0,11 (0,20)	0,11 (0,20)	0,11 (0,20)	0,11 (0,20)	0,11 (0,20)	0,11 (0,20)	
Ramp time		45 min	55 min	55 min	60 min	60 min	65 min	



Table E.4 (continued)

1	2		3		4		5		6		7		8		9
Time min	Pressure kPa (psi)		Temperature gradient, °C/100 m depth (°F/100 ft depth)												Stirring
			1,6 (0,9)	2,0 (1,1)	2,4 (1,3)	2,7 (1,5)	3,1 (1,7)	3,5 (1,9)	Temperature						
	°C (°F)	°C (°F)	°C (°F)	°C (°F)	°C (°F)	°C (°F)	°C (°F)	°C (°F)	°C (°F)	°C (°F)	°C (°F)	°C (°F)	Depth: 610 m (2 000 ft) Mud density: 1,13 kg/l (9,40 lbm/gal)		
0	3 400 (500)		27 (80)	27 (80)	27 (80)	27 (80)	27 (80)	27 (80)	27 (80)	27 (80)	27 (80)	27 (80)	27 (80)	27 (80)	On
1	4 100 (600)		28 (82)	28 (82)	28 (83)	28 (83)	28 (83)	29 (84)	29 (84)	29 (85)	29 (85)	29 (85)	29 (85)	29 (85)	On
2	4 800 (700)		28 (83)	29 (85)	30 (86)	30 (86)	31 (88)	31 (88)	32 (89)	32 (89)	33 (91)	33 (91)	33 (91)	33 (91)	On
3	5 500 (800)		29 (85)	31 (87)	31 (89)	31 (89)	33 (91)	33 (91)	34 (94)	34 (94)	36 (96)	36 (96)	36 (96)	36 (96)	On
4	6 200 (900)		30 (86)	32 (89)	33 (92)	33 (92)	35 (95)	35 (95)	37 (98)	37 (98)	38 (101)	38 (101)	38 (101)	38 (101)	On
5	6 500 (940)		30 (86)	32 (89)	33 (92)	33 (92)	35 (95)	35 (95)	37 (98)	37 (98)	38 (101)	38 (101)	38 (101)	38 (101)	On
6	6 800 (980)		30 (86)	32 (89)	33 (92)	33 (92)	35 (95)	35 (95)	37 (98)	37 (98)	38 (101)	38 (101)	38 (101)	38 (101)	On
7	7 000 (1 020)		30 (86)	32 (89)	33 (92)	33 (92)	35 (95)	35 (95)	37 (98)	37 (98)	38 (101)	38 (101)	38 (101)	38 (101)	On
8	7 300 (1 060)		30 (86)	32 (89)	33 (92)	33 (92)	35 (95)	35 (95)	37 (98)	37 (98)	38 (101)	38 (101)	38 (101)	38 (101)	On
9	7 600 (1 100)		30 (86)	32 (89)	33 (92)	33 (92)	35 (95)	35 (95)	37 (98)	37 (98)	38 (101)	38 (101)	38 (101)	38 (101)	On
10	7 900 (1 140)		30 (86)	32 (89)	33 (92)	33 (92)	35 (95)	35 (95)	37 (98)	37 (98)	38 (101)	38 (101)	38 (101)	38 (101)	On
11	8 100 (1 180)		30 (86)	32 (89)	33 (92)	33 (92)	35 (95)	35 (95)	37 (98)	37 (98)	38 (101)	38 (101)	38 (101)	38 (101)	On
12	8 400 (1 220)		30 (86)	32 (89)	33 (92)	33 (92)	35 (95)	35 (95)	37 (98)	37 (98)	38 (101)	38 (101)	38 (101)	38 (101)	On
13	8 700 (1 260)		30 (86)	32 (89)	33 (92)	33 (92)	35 (95)	35 (95)	37 (98)	37 (98)	38 (101)	38 (101)	38 (101)	38 (101)	On
14	9 000 (1 300)		30 (86)	32 (89)	33 (92)	33 (92)	35 (95)	35 (95)	37 (98)	37 (98)	38 (101)	38 (101)	38 (101)	38 (101)	On
15	9 200 (1 340)		30 (86)	32 (89)	33 (92)	33 (92)	35 (95)	35 (95)	37 (98)	37 (98)	38 (101)	38 (101)	38 (101)	38 (101)	On
16	9 500 (1 380)		30 (86)	32 (89)	33 (92)	33 (92)	35 (95)	35 (95)	37 (98)	37 (98)	38 (101)	38 (101)	38 (101)	38 (101)	On
17	9 800 (1 420)		30 (86)	32 (89)	33 (92)	33 (92)	35 (95)	35 (95)	37 (98)	37 (98)	38 (101)	38 (101)	38 (101)	38 (101)	On
18	10 100 (1 460)		30 (86)	32 (89)	33 (92)	33 (92)	35 (95)	35 (95)	37 (98)	37 (98)	38 (101)	38 (101)	38 (101)	38 (101)	On
19	10 300 (1 500)		30 (86)	32 (89)	33 (92)	33 (92)	35 (95)	35 (95)	37 (98)	37 (98)	38 (101)	38 (101)	38 (101)	38 (101)	On
20	10 600 (1 540)		30 (86)	32 (89)	33 (92)	33 (92)	35 (95)	35 (95)	37 (98)	37 (98)	38 (101)	38 (101)	38 (101)	38 (101)	Off
30	10 600 (1 540)		31 (88)	33 (91)	34 (94)	34 (94)	36 (97)	36 (97)	38 (100)	38 (100)	39 (103)	39 (103)	39 (103)	39 (103)	On
35	10 600 (1 540)		32 (89)	33 (92)	35 (95)	35 (95)	37 (98)	37 (98)	38 (101)	38 (101)	40 (104)	40 (104)	40 (104)	40 (104)	Off
45	10 600 (1 540)		33 (91)	34 (94)	36 (97)	36 (97)	38 (100)	38 (100)	39 (103)	39 (103)	41 (106)	41 (106)	41 (106)	41 (106)	On
50	10 600 (1 540)		33 (92)	35 (95)	37 (98)	37 (98)	38 (101)	38 (101)	40 (104)	40 (104)	42 (107)	42 (107)	42 (107)	42 (107)	Off
60	10 600 (1 540)		34 (94)	36 (97)	38 (100)	38 (100)	39 (103)	39 (103)	41 (106)	41 (106)	43 (109)	43 (109)	43 (109)	43 (109)	On
65	10 600 (1 540)		35 (95)	37 (98)	38 (101)	38 (101)	40 (104)	40 (104)	42 (107)	42 (107)	43 (110)	43 (110)	43 (110)	43 (110)	Off
75	10 600 (1 540)		36 (97)	38 (100)	39 (103)	39 (103)	41 (106)	41 (106)	43 (109)	43 (109)	44 (112)	44 (112)	44 (112)	44 (112)	On
80	10 600 (1 540)		37 (98)	38 (101)	40 (104)	40 (104)	42 (107)	42 (107)	43 (110)	43 (110)	45 (113)	45 (113)	45 (113)	45 (113)	Off
90	10 600 (1 540)		37 (98)	39 (102)	41 (106)	41 (106)	43 (109)	43 (109)	44 (112)	44 (112)	46 (115)	46 (115)	46 (115)	46 (115)	On
95	10 600 (1 540)		37 (98)	39 (102)	41 (106)	41 (106)	43 (110)	43 (110)	45 (113)	45 (113)	47 (116)	47 (116)	47 (116)	47 (116)	Off
105	10 600 (1 540)		37 (98)	39 (102)	41 (106)	41 (106)	43 (110)	43 (110)	46 (114)	46 (114)	48 (118)	48 (118)	48 (118)	48 (118)	On
110	10 600 (1 540)		37 (98)	39 (102)	41 (106)	41 (106)	43 (110)	43 (110)	46 (114)	46 (114)	48 (118)	48 (118)	48 (118)	48 (118)	Off
120	10 600 (1 540)		37 (98)	39 (102)	41 (106)	41 (106)	43 (110)	43 (110)	46 (114)	46 (114)	48 (118)	48 (118)	48 (118)	48 (118)	On
125	10 600 (1 540)		37 (98)	39 (102)	41 (106)	41 (106)	43 (110)	43 (110)	46 (114)	46 (114)	48 (118)	48 (118)	48 (118)	48 (118)	Off

Table E.4 (continued)

1	2	3	4	5	6	7	8	9
Time	Pressure	Temperature gradient, °C/100 m depth (°F/100 ft depth)						Stirring
		1,6 (0,9)	2,0 (1,1)	2,4 (1,3)	2,7 (1,5)	3,1 (1,7)	3,5 (1,9)	
		Temperature						
min	kPa (psi)	°C (°F)	°C (°F)	°C (°F)	°C (°F)	°C (°F)	°C (°F)	
Depth: 610 m (2 000 ft)				Mud density: 1,13 kg/l (9,40 lbm/gal)				
135	10 600 (1 540)	37 (98)	39 (102)	41 (106)	43 (110)	46 (114)	48 (118)	On
140	10 600 (1 540)	37 (98)	39 (102)	41 (106)	43 (110)	46 (114)	48 (118)	Off
<b>Segment 1</b>								
Ramp (deg/min)		0,83 (1,50)	1,25 (2,25)	1,67 (3,00)	2,08 (3,75)	2,50 (4,50)	2,92 (5,25)	
Ramp time		4 min						
Temp. dwell		16 min						
Pressure rate (per min)		700 kPa (100 psi) for 4 min, then 275 kPa (40 psi) for 16 min						
<b>Segment 2</b>								
Ramp (deg/min)		0,11 (0,20)	0,11 (0,20)	0,11 (0,20)	0,11 (0,20)	0,11 (0,20)	0,11 (0,20)	
Ramp time		60 min	65 min	70 min	75 min	80 min	85 min	

Table E.4 (continued)

1	2	3	4	5	6	7	8	9
Time min	Pressure kPa (psi)	Temperature gradient, °C/100 m depth (°F/100 ft depth)						Stirring
		1,6 (0,9)	2,0 (1,1)	2,4 (1,3)	2,7 (1,5)	3,1 (1,7)	3,5 (1,9)	
		Temperature						
		°C (°F)	°C (°F)	°C (°F)	°C (°F)	°C (°F)	°C (°F)	
Depth: 1 220 m (4 000 ft)				Mud density: 1,16 kg/l (9,7 lbm/gal)				
0	3 400 (500)	27 (80)	27 (80)	27 (80)	27 (80)	27 (80)	27 (80)	On
1	4 600 (660)	28 (82)	28 (83)	29 (84)	29 (84)	29 (85)	30 (86)	On
2	5 700 (820)	29 (84)	30 (86)	31 (87)	32 (89)	32 (90)	33 (92)	On
3	6 800 (980)	31 (87)	32 (89)	33 (91)	34 (93)	35 (95)	36 (97)	On
4	7 900 (1 140)	32 (89)	33 (92)	35 (95)	36 (97)	38 (100)	39 (103)	On
5	9 000 (1 300)	33 (91)	34 (94)	37 (98)	39 (102)	41 (105)	43 (109)	On
6	10 100 (1 460)	34 (93)	36 (97)	39 (102)	41 (106)	43 (110)	46 (115)	On
7	11 200 (1 620)	36 (96)	38 (100)	41 (106)	43 (110)	46 (115)	49 (120)	On
8	12 300 (1 780)	37 (98)	39 (103)	43 (109)	46 (115)	49 (120)	52 (126)	On
9	13 400 (1 940)	38 (100)	41 (106)	45 (113)	48 (119)	52 (125)	56 (132)	On
10	13 800 (2 005)	38 (100)	41 (106)	45 (113)	48 (119)	52 (125)	56 (132)	On
11	14 300 (2 070)	38 (100)	41 (106)	45 (113)	48 (119)	52 (125)	56 (132)	On
12	14 700 (2 135)	38 (100)	41 (106)	45 (113)	48 (119)	52 (125)	56 (132)	On
13	15 200 (2 200)	38 (100)	41 (106)	45 (113)	48 (119)	52 (125)	56 (132)	On
14	15 600 (2 265)	38 (100)	41 (106)	45 (113)	48 (119)	52 (125)	56 (132)	On
15	16 100 (2 330)	38 (100)	41 (106)	45 (113)	48 (119)	52 (125)	56 (132)	On
16	16 500 (2 395)	38 (100)	41 (106)	45 (113)	48 (119)	52 (125)	56 (132)	On
17	17 000 (2 460)	38 (100)	41 (106)	45 (113)	48 (119)	52 (125)	56 (132)	On
18	17 400 (2 525)	38 (100)	41 (106)	45 (113)	48 (119)	52 (125)	56 (132)	On
19	17 900 (2 590)	38 (100)	41 (106)	45 (113)	48 (119)	52 (125)	56 (132)	On
20	18 300 (2 655)	38 (100)	41 (106)	45 (113)	48 (119)	52 (125)	56 (132)	On
21	18 800 (2 720)	38 (100)	41 (106)	45 (113)	48 (119)	52 (125)	56 (132)	On
22	19 200 (2 785)	38 (100)	41 (106)	45 (113)	48 (119)	52 (125)	56 (132)	On
23	19 700 (2 850)	38 (100)	41 (106)	45 (113)	48 (119)	52 (125)	56 (132)	On
24	20 100 (2 915)	38 (100)	41 (106)	45 (113)	48 (119)	52 (125)	56 (132)	On
25	20 500 (2 980)	38 (100)	41 (106)	45 (113)	48 (119)	52 (125)	56 (132)	Off
35	20 500 (2 980)	39 (102)	42 (108)	46 (115)	49 (121)	53 (127)	57 (134)	On
40	20 500 (2 980)	39 (103)	43 (109)	47 (116)	50 (122)	53 (128)	57 (135)	Off
50	20 500 (2 980)	41 (105)	44 (111)	48 (118)	51 (124)	54 (130)	58 (137)	On
55	20 500 (2 980)	41 (106)	44 (112)	48 (119)	52 (125)	55 (131)	59 (138)	Off
65	20 500 (2 980)	42 (108)	46 (114)	49 (121)	53 (127)	56 (133)	60 (140)	On
70	20 500 (2 980)	43 (109)	46 (115)	50 (122)	53 (128)	57 (134)	61 (141)	Off
80	20 500 (2 980)	44 (111)	47 (117)	51 (124)	54 (130)	58 (136)	62 (143)	On
85	20 500 (2 980)	44 (112)	48 (118)	52 (125)	55 (131)	58 (137)	62 (144)	Off
95	20 500 (2 980)	46 (114)	49 (120)	53 (127)	56 (133)	59 (139)	63 (146)	On

Table E.4 (continued)

1	2	3	4	5	6	7	8	9
Time min	Pressure kPa (psi)	Temperature gradient, °C/100 m depth (°F/100 ft depth)						Stirring
		1,6 (0,9)	2,0 (1,1)	2,4 (1,3)	2,7 (1,5)	3,1 (1,7)	3,5 (1,9)	
		Temperature						
		°C (°F)	°C (°F)	°C (°F)	°C (°F)	°C (°F)	°C (°F)	
Depth: 1 220 m (4 000 ft)				Mud density: 1,16 kg/l (9,7 lbm/gal)				
100	20 500 (2 980)	46 (115)	49 (121)	53 (128)	57 (134)	60 (140)	64 (147)	Off
110	20 500 (2 980)	47 (116)	51 (123)	54 (130)	58 (136)	61 (142)	65 (149)	On
115	20 500 (2 980)	47 (116)	51 (124)	55 (131)	58 (137)	62 (143)	66 (150)	Off
125	20 500 (2 980)	47 (116)	51 (124)	56 (132)	59 (139)	63 (145)	67 (152)	On
130	20 500 (2 980)	47 (116)	51 (124)	56 (132)	60 (140)	63 (146)	67 (153)	Off
140	20 500 (2 980)	47 (116)	51 (124)	56 (132)	60 (140)	64 (148)	68 (155)	On
145	20 500 (2 980)	47 (116)	51 (124)	56 (132)	60 (140)	64 (148)	69 (156)	Off
155	20 500 (2 980)	47 (116)	51 (124)	56 (132)	60 (140)	64 (148)	69 (156)	On
160	20 500 (2 980)	47 (116)	51 (124)	56 (132)	60 (140)	64 (148)	69 (156)	Off
170	20 500 (2 980)	47 (116)	51 (124)	56 (132)	60 (140)	64 (148)	69 (156)	On
<b>Segment 1</b>								
Ramp (deg/min)		1,23 (2,22)	1,61 (2,89)	2,04 (3,67)	2,41 (4,33)	2,78 (5,00)	3,21 (5,78)	
Ramp time		9 min						
Temp. dwell		16 min						
Pressure rate (per min)		1 111 kPa (160 psi) for 9 min, then 444 kPa (65 psi) for 16 min						
<b>Segment 2</b>								
Ramp (deg/min)		0,11 (0,20)	0,11 (0,20)	0,11 (0,20)	0,11 (0,20)	0,11 (0,20)	0,11 (0,20)	
Ramp time		80 min	90 min	95 min	105 min	115 min	120 min	

Table E.4 (continued)

1	2	3	4	5	6	7	8	9
Time min	Pressure kPa (psi)	Temperature gradient, °C/100 m depth (°F/100 ft depth)						Stirring
		1,6 (0,9)	2,0 (1,1)	2,4 (1,3)	2,7 (1,5)	3,1 (1,7)	3,5 (1,9)	
		Temperature						
		°C (°F)	°C (°F)	°C (°F)	°C (°F)	°C (°F)	°C (°F)	
Depth: 1 830 m (6 000 ft)				Mud density: 1,22 kg/l (10,2 lbm/gal)				
0	5 500 (800)	27 (80)	27 (80)	27 (80)	27 (80)	27 (80)	27 (80)	On
1	6 700 (970)	28 (83)	28 (83)	29 (84)	29 (85)	29 (85)	30 (86)	On
2	7 900 (1 140)	29 (85)	30 (86)	31 (88)	32 (89)	32 (90)	33 (92)	On
3	9 000 (1 310)	31 (88)	32 (89)	33 (92)	34 (94)	36 (96)	37 (98)	On
4	10 200 (1 480)	32 (90)	34 (93)	35 (95)	37 (98)	38 (101)	40 (104)	On
5	11 400 (1 650)	34 (93)	36 (96)	37 (99)	39 (103)	41 (106)	43 (110)	On
6	12 500 (1 820)	35 (95)	37 (99)	39 (103)	42 (107)	44 (111)	47 (116)	On
7	13 700 (1 990)	37 (98)	39 (102)	42 (107)	44 (112)	47 (117)	50 (122)	On
8	14 900 (2 160)	38 (100)	41 (105)	44 (111)	47 (117)	50 (122)	53 (127)	On
9	16 100 (2 330)	39 (103)	42 (108)	46 (115)	49 (121)	53 (127)	56 (133)	On
10	17 200 (2 500)	41 (105)	44 (111)	48 (119)	52 (126)	56 (132)	59 (139)	On
11	18 400 (2 670)	42 (108)	46 (115)	50 (122)	54 (130)	58 (137)	63 (145)	On
12	19 600 (2 840)	43 (110)	48 (118)	52 (126)	57 (135)	62 (143)	66 (151)	On
13	20 800 (3 010)	45 (113)	49 (121)	54 (130)	59 (139)	64 (148)	69 (157)	On
14	21 900 (3 180)	46 (115)	51 (124)	57 (134)	62 (144)	67 (153)	73 (163)	On
15	22 400 (3 250)	46 (115)	51 (124)	57 (134)	62 (144)	67 (153)	73 (163)	On
16	22 900 (3 320)	46 (115)	51 (124)	57 (134)	62 (144)	67 (153)	73 (163)	On
17	23 400 (3 390)	46 (115)	51 (124)	57 (134)	62 (144)	67 (153)	73 (163)	On
18	23 900 (3 460)	46 (115)	51 (124)	57 (134)	62 (144)	67 (153)	73 (163)	On
19	24 300 (3 530)	46 (115)	51 (124)	57 (134)	62 (144)	67 (153)	73 (163)	On
20	24 800 (3 600)	46 (115)	51 (124)	57 (134)	62 (144)	67 (153)	73 (163)	On
21	25 300 (3 670)	46 (115)	51 (124)	57 (134)	62 (144)	67 (153)	73 (163)	On
22	25 800 (3 740)	46 (115)	51 (124)	57 (134)	62 (144)	67 (153)	73 (163)	On
23	26 300 (3 810)	46 (115)	51 (124)	57 (134)	62 (144)	67 (153)	73 (163)	On
24	26 800 (3 880)	46 (115)	51 (124)	57 (134)	62 (144)	67 (153)	73 (163)	On
25	27 200 (3 950)	46 (115)	51 (124)	57 (134)	62 (144)	67 (153)	73 (163)	On
26	27 700 (4 020)	46 (115)	51 (124)	57 (134)	62 (144)	67 (153)	73 (163)	On
27	28 200 (4 090)	46 (115)	51 (124)	57 (134)	62 (144)	67 (153)	73 (163)	On
28	28 700 (4 160)	46 (115)	51 (124)	57 (134)	62 (144)	67 (153)	73 (163)	On
29	29 200 (4 230)	46 (115)	51 (124)	57 (134)	62 (144)	67 (153)	73 (163)	On
30	29 600 (4 300)	46 (115)	51 (124)	57 (134)	62 (144)	67 (153)	73 (163)	On
31	30 100 (4 370)	46 (115)	51 (124)	57 (134)	62 (144)	67 (153)	73 (163)	On
32	30 600 (4 440)	46 (115)	51 (124)	57 (134)	62 (144)	67 (153)	73 (163)	On
33	31 100 (4 510)	46 (115)	51 (124)	57 (134)	62 (144)	67 (153)	73 (163)	On
34	31 600 (4 580)	46 (115)	51 (124)	57 (134)	62 (144)	67 (153)	73 (163)	On

Table E.4 (continued)

1	2	3	4	5	6	7	8	9
Time min	Pressure kPa (psi)	Temperature gradient, °C/100 m depth (°F/100 ft depth)						Stirring
		1,6 (0,9)	2,0 (1,1)	2,4 (1,3)	2,7 (1,5)	3,1 (1,7)	3,5 (1,9)	
		Temperature						
		°C (°F)	°C (°F)	°C (°F)	°C (°F)	°C (°F)	°C (°F)	
Depth: 1 830 m (6 000 ft)				Mud density: 1,22 kg/l (10,2 lbm/gal)				
35	32 100 (4 650)	46 (115)	51 (124)	57 (134)	62 (144)	67 (153)	73 (163)	On
45	32 100 (4 650)	47 (117)	52 (126)	58 (136)	63 (146)	68 (155)	74 (165)	Off
50	32 100 (4 650)	48 (118)	53 (127)	58 (137)	64 (147)	69 (156)	74 (166)	On
60	32 100 (4 650)	49 (120)	54 (129)	59 (139)	65 (149)	70 (158)	76 (168)	Off
65	32 100 (4 650)	49 (121)	54 (130)	60 (140)	66 (150)	71 (159)	76 (169)	On
75	32 100 (4 650)	51 (123)	56 (132)	61 (142)	67 (152)	72 (161)	77 (171)	Off
80	32 100 (4 650)	51 (124)	56 (133)	62 (143)	67 (153)	72 (162)	78 (172)	On
90	32 100 (4 650)	52 (126)	57 (135)	63 (145)	68 (155)	73 (164)	79 (174)	Off
95	32 100 (4 650)	53 (127)	58 (136)	63 (146)	69 (156)	74 (165)	79 (175)	On
105	32 100 (4 650)	54 (129)	59 (138)	64 (148)	70 (158)	75 (167)	81 (177)	Off
110	32 100 (4 650)	54 (130)	59 (139)	65 (149)	71 (159)	76 (168)	81 (178)	On
120	32 100 (4 650)	56 (132)	61 (141)	66 (151)	72 (161)	77 (170)	82 (180)	Off
125	32 100 (4 650)	56 (133)	61 (142)	67 (152)	72 (162)	77 (171)	83 (181)	On
135	32 100 (4 650)	57 (134)	62 (144)	68 (154)	73 (164)	78 (173)	84 (183)	Off
140	32 100 (4 650)	57 (134)	63 (145)	68 (155)	74 (165)	79 (174)	84 (184)	On
150	32 100 (4 650)	57 (134)	63 (146)	69 (157)	75 (167)	80 (176)	86 (186)	Off
155	32 100 (4 650)	57 (134)	63 (146)	70 (158)	76 (168)	81 (177)	86 (187)	On
165	32 100 (4 650)	57 (134)	63 (146)	70 (158)	77 (170)	82 (179)	87 (189)	Off
170	32 100 (4 650)	57 (134)	63 (146)	70 (158)	77 (170)	82 (180)	88 (190)	On
180	32 100 (4 650)	57 (134)	63 (146)	70 (158)	77 (170)	83 (182)	89 (192)	Off
185	32 100 (4 650)	57 (134)	63 (146)	70 (158)	77 (170)	83 (182)	89 (193)	On
195	32 100 (4 650)	57 (134)	63 (146)	70 (158)	77 (170)	83 (182)	90 (194)	Off
200	32 100 (4 650)	57 (134)	63 (146)	70 (158)	77 (170)	83 (182)	90 (194)	On
<b>Segment 1</b>								
Ramp (deg/min)		1,39 (2,50)	1,74 (3,14)	2,14 (3,86)	2,54 (4,57)	2,89 (5,21)	3,29 (5,93)	
Ramp time		14 min						
Temp. dwell		21 min						
Pressure rate (per min)		1 171 kPa (170 psi) for 14 min, then 486 kPa (70 psi) for 21 min						
<b>Segment 2</b>								
Ramp (deg/min)		0,11 (0,20)	0,11 (0,20)	0,11 (0,20)	0,11 (0,20)	0,11 (0,20)	0,11 (0,20)	
Ramp time		95 min	110 min	120 min	130 min	145 min	155 min	

Table E.4 (continued)

1	2	3	4	5	6	7	8	9
Time min	Pressure kPa (psi)	Temperature gradient, °C/100 m depth (°F/100 ft depth)						Stirring
		1,6 (0,9)	2,0 (1,1)	2,4 (1,3)	2,7 (1,5)	3,1 (1,7)	3,5 (1,9)	
		Temperature						
		°C (°F)	°C (°F)	°C (°F)	°C (°F)	°C (°F)	°C (°F)	
Depth: 2 440 m (8 000 ft)				Mud density: 1,29 kg/l (10,8 lbm/gal)				
0	6 900 (1 000)	27 (80)	27 (80)	27 (80)	27 (80)	27 (80)	27 (80)	On
1	8 200 (1 185)	28 (83)	28 (83)	29 (84)	29 (85)	29 (85)	30 (86)	On
2	9 400 (1 370)	29 (85)	31 (87)	31 (88)	32 (89)	33 (91)	33 (92)	On
3	10 700 (1 555)	31 (88)	32 (90)	33 (92)	34 (94)	36 (96)	37 (98)	On
4	12 000 (1 740)	33 (91)	34 (93)	36 (96)	37 (99)	38 (101)	40 (104)	On
5	13 300 (1 925)	34 (93)	36 (97)	38 (100)	39 (103)	42 (107)	44 (111)	On
6	14 500 (2 110)	36 (96)	38 (100)	40 (104)	42 (108)	44 (112)	47 (117)	On
7	15 800 (2 295)	37 (98)	39 (103)	42 (108)	45 (113)	48 (118)	51 (123)	On
8	17 100 (2 480)	38 (101)	42 (107)	44 (112)	47 (117)	51 (123)	54 (129)	On
9	18 400 (2 665)	40 (104)	43 (110)	47 (116)	50 (122)	53 (128)	57 (135)	On
10	19 700 (2 850)	41 (106)	45 (113)	49 (120)	53 (127)	57 (134)	61 (141)	On
11	20 900 (3 035)	43 (109)	47 (116)	51 (124)	56 (132)	59 (139)	64 (147)	On
12	22 200 (3 220)	44 (112)	49 (120)	53 (128)	58 (136)	62 (144)	67 (153)	On
13	23 500 (3 405)	46 (114)	51 (123)	56 (132)	61 (141)	66 (150)	71 (159)	On
14	24 800 (3 590)	47 (117)	52 (126)	58 (136)	63 (146)	68 (155)	74 (165)	On
15	26 000 (3 775)	48 (119)	54 (130)	60 (140)	66 (150)	72 (161)	78 (172)	On
16	27 300 (3 960)	50 (122)	56 (133)	62 (144)	68 (155)	74 (166)	81 (178)	On
17	28 600 (4 145)	52 (125)	58 (136)	64 (148)	71 (160)	77 (171)	84 (184)	On
18	29 900 (4 330)	53 (127)	60 (140)	67 (152)	73 (164)	81 (177)	88 (190)	On
19	31 100 (4 515)	54 (130)	62 (143)	69 (156)	76 (169)	83 (182)	91 (196)	On
20	31 700 (4 600)	54 (130)	62 (143)	69 (156)	76 (169)	83 (182)	91 (196)	On
21	32 300 (4 685)	54 (130)	62 (143)	69 (156)	76 (169)	83 (182)	91 (196)	On
22	32 900 (4 770)	54 (130)	62 (143)	69 (156)	76 (169)	83 (182)	91 (196)	On
23	33 500 (4 855)	54 (130)	62 (143)	69 (156)	76 (169)	83 (182)	91 (196)	On
24	34 100 (4 940)	54 (130)	62 (143)	69 (156)	76 (169)	83 (182)	91 (196)	On
25	34 600 (5 025)	54 (130)	62 (143)	69 (156)	76 (169)	83 (182)	91 (196)	On
26	35 200 (5 110)	54 (130)	62 (143)	69 (156)	76 (169)	83 (182)	91 (196)	On
27	35 800 (5 195)	54 (130)	62 (143)	69 (156)	76 (169)	83 (182)	91 (196)	On
28	36 400 (5 280)	54 (130)	62 (143)	69 (156)	76 (169)	83 (182)	91 (196)	On
29	37 000 (5 365)	54 (130)	62 (143)	69 (156)	76 (169)	83 (182)	91 (196)	On
30	37 600 (5 450)	54 (130)	62 (143)	69 (156)	76 (169)	83 (182)	91 (196)	On
31	38 200 (5 535)	54 (130)	62 (143)	69 (156)	76 (169)	83 (182)	91 (196)	On
32	38 700 (5 620)	54 (130)	62 (143)	69 (156)	76 (169)	83 (182)	91 (196)	On
33	39 300 (5 705)	54 (130)	62 (143)	69 (156)	76 (169)	83 (182)	91 (196)	On
34	39 900 (5 790)	54 (130)	62 (143)	69 (156)	76 (169)	83 (182)	91 (196)	On

Table E.4 (continued)

1	2	3	4	5	6	7	8	9
Time	Pressure	Temperature gradient, °C/100 m depth (°F/100 ft depth)						Stirring
		1,6 (0,9)	2,0 (1,1)	2,4 (1,3)	2,7 (1,5)	3,1 (1,7)	3,5 (1,9)	
min	kPa (psi)	Temperature						
		°C (°F)	°C (°F)	°C (°F)	°C (°F)	°C (°F)	°C (°F)	
Depth: 2 440 m (8 000 ft)				Mud density: 1,29 kg/l (10,8 lbm/gal)				
35	40 500 (5 875)	54 (130)	62 (143)	69 (156)	76 (169)	83 (182)	91 (196)	On
36	41 100 (5 960)	54 (130)	62 (143)	69 (156)	76 (169)	83 (182)	91 (196)	On
37	41 700 (6 045)	54 (130)	62 (143)	69 (156)	76 (169)	83 (182)	91 (196)	On
38	42 300 (6 130)	54 (130)	62 (143)	69 (156)	76 (169)	83 (182)	91 (196)	On
39	42 900 (6 215)	54 (130)	62 (143)	69 (156)	76 (169)	83 (182)	91 (196)	On
40	43 400 (6 300)	54 (130)	62 (143)	69 (156)	76 (169)	83 (182)	91 (196)	Off
50	43 400 (6 300)	56 (132)	63 (145)	70 (158)	77 (171)	84 (184)	92 (198)	On
55	43 400 (6 300)	56 (133)	63 (146)	71 (159)	78 (172)	85 (185)	93 (199)	Off
65	43 400 (6 300)	57 (135)	64 (148)	72 (161)	79 (174)	86 (187)	94 (201)	On
70	43 400 (6 300)	58 (136)	65 (149)	72 (162)	79 (175)	87 (188)	94 (202)	Off
80	43 400 (6 300)	59 (138)	66 (151)	73 (164)	81 (177)	88 (190)	96 (204)	On
85	43 400 (6 300)	59 (139)	67 (152)	74 (165)	81 (178)	88 (191)	96 (205)	Off
95	43 400 (6 300)	61 (141)	68 (154)	75 (167)	82 (180)	89 (193)	97 (207)	On
100	43 400 (6 300)	61 (142)	68 (155)	76 (168)	83 (181)	90 (194)	98 (208)	Off
110	43 400 (6 300)	62 (144)	69 (157)	77 (170)	84 (183)	91 (196)	99 (210)	On
115	43 400 (6 300)	63 (145)	70 (158)	77 (171)	84 (184)	92 (197)	99 (211)	Off
125	43 400 (6 300)	64 (147)	71 (160)	78 (173)	86 (186)	93 (199)	101 (213)	On
130	43 400 (6 300)	64 (148)	72 (161)	79 (174)	86 (187)	93 (200)	101 (214)	Off
140	43 400 (6 300)	66 (150)	73 (163)	80 (176)	87 (189)	94 (202)	102 (216)	On
145	43 400 (6 300)	66 (151)	73 (164)	81 (177)	88 (190)	95 (203)	103 (217)	Off
155	43 400 (6 300)	67 (152)	74 (166)	82 (179)	89 (192)	96 (205)	104 (219)	On
160	43 400 (6 300)	67 (152)	75 (167)	82 (180)	89 (193)	97 (206)	104 (220)	Off
170	43 400 (6 300)	67 (152)	76 (168)	83 (182)	91 (195)	98 (208)	106 (222)	On
175	43 400 (6 300)	67 (152)	76 (168)	84 (183)	91 (196)	98 (209)	106 (223)	Off
185	43 400 (6 300)	67 (152)	76 (168)	84 (184)	92 (198)	99 (211)	107 (225)	On
190	43 400 (6 300)	67 (152)	76 (168)	84 (184)	93 (199)	100 (212)	108 (226)	Off
200	43 400 (6 300)	67 (152)	76 (168)	84 (184)	93 (200)	101 (214)	109 (228)	On
205	43 400 (6 300)	67 (152)	76 (168)	84 (184)	93 (200)	102 (215)	109 (229)	Off
215	43 400 (6 300)	67 (152)	76 (168)	84 (184)	93 (200)	102 (216)	111 (231)	On
220	43 400 (6 300)	67 (152)	76 (168)	84 (184)	93 (200)	102 (216)	111 (232)	Off



Table E.4 (continued)

1	2	3	4	5	6	7	8	9
Time min	Pressure kPa (psi)	Temperature gradient, °C/100 m depth (°F/100 ft depth)						Stirring
		1,6 (0,9)	2,0 (1,1)	2,4 (1,3)	2,7 (1,5)	3,1 (1,7)	3,5 (1,9)	
		Temperature						
		°C (°F)	°C (°F)	°C (°F)	°C (°F)	°C (°F)	°C (°F)	
		Depth: 2 440 m (8 000 ft)			Mud density: 1,29 kg/l (10,8 lbm/gal)			
230	43 400 (6 300)	67 (152)	76 (168)	84 (184)	93 (200)	102 (216)	111 (232)	On
235	43 400 (6 300)	67 (152)	76 (168)	84 (184)	93 (200)	102 (216)	111 (232)	Off
<b>Segment 1</b>								
Ramp (deg/min)		1,46 (2,63)	1,84 (3,32)	2,22 (4,00)	2,60 (4,68)	2,98 (5,57)	3,39 (6,11)	
Ramp time		19 min						
Temp. dwell		21 min						
Pressure rate (per min)		1 379 kPa (185 psi) for 19 min, then 586 kPa (85 psi) for 21 min						
<b>Segment 2</b>								
Ramp (deg/min)		0,11 (0,20)	0,11 (0,20)	0,11 (0,20)	0,11 (0,20)	0,11 (0,20)	0,11 (0,20)	
Ramp time		110 min	125 min	140 min	155 min	170 min	180 min	

Table E.4 (continued)

1	2	3	4	5	6	7	8	9
Time min	Pressure kPa (psi)	Temperature gradient, °C/100 m depth (°F/100 ft depth)						Stirring
		1,6 (0,9)	2,0 (1,1)	2,4 (1,3)	2,7 (1,5)	3,1 (1,7)	3,5 (1,9)	
		Temperature						
		°C (°F)	°C (°F)	°C (°F)	°C (°F)	°C (°F)	°C (°F)	
Depth: 3 050 m (10 000 ft)				Mud density: 1,38 kg/l (11,5 lbm/gal)				
0	9 000 (1 300)	27 (80)	27 (80)	27 (80)	27 (80)	27 (80)	27 (80)	On
1	10 300 (1 500)	28 (83)	28 (83)	29 (84)	29 (85)	30 (86)	30 (86)	On
2	11 700 (1 700)	30 (86)	31 (87)	31 (88)	32 (90)	33 (91)	33 (92)	On
3	13 100 (1 900)	31 (88)	32 (90)	33 (92)	35 (95)	36 (97)	37 (99)	On
4	14 500 (2 100)	33 (91)	34 (94)	36 (97)	37 (99)	39 (102)	41 (105)	On
5	15 900 (2 300)	34 (94)	36 (97)	38 (101)	40 (104)	42 (108)	44 (111)	On
6	17 200 (2 500)	36 (97)	38 (101)	41 (105)	43 (109)	45 (113)	47 (117)	On
7	18 600 (2 700)	37 (99)	40 (104)	43 (109)	46 (114)	48 (119)	51 (123)	On
8	20 000 (2 900)	39 (102)	42 (108)	45 (113)	48 (119)	51 (124)	54 (130)	On
9	21 400 (3 100)	41 (105)	44 (111)	47 (117)	51 (124)	54 (130)	58 (136)	On
10	22 800 (3 300)	42 (108)	46 (115)	49 (121)	53 (128)	57 (135)	61 (142)	On
11	24 100 (3 500)	43 (110)	48 (118)	52 (125)	56 (133)	61 (141)	64 (148)	On
12	25 500 (3 700)	45 (113)	50 (122)	54 (130)	59 (138)	64 (147)	68 (155)	On
13	26 900 (3 900)	47 (116)	52 (125)	57 (134)	62 (143)	67 (152)	72 (161)	On
14	28 300 (4 100)	48 (119)	53 (128)	59 (138)	64 (148)	70 (158)	75 (167)	On
15	29 600 (4 300)	49 (121)	56 (132)	61 (142)	67 (153)	73 (163)	78 (173)	On
16	31 000 (4 500)	51 (124)	57 (135)	63 (146)	69 (157)	76 (169)	82 (179)	On
17	32 400 (4 700)	53 (127)	59 (139)	66 (150)	72 (162)	79 (174)	86 (186)	On
18	33 800 (4 900)	54 (130)	61 (142)	68 (154)	75 (167)	82 (180)	89 (192)	On
19	35 200 (5 100)	56 (132)	63 (146)	70 (158)	78 (172)	85 (185)	92 (198)	On
20	36 500 (5 300)	57 (135)	65 (149)	73 (163)	81 (177)	88 (191)	96 (204)	On
21	37 900 (5 500)	59 (138)	67 (153)	75 (167)	83 (182)	91 (196)	99 (210)	On
22	39 300 (5 700)	61 (141)	69 (156)	77 (171)	86 (186)	94 (202)	103 (217)	On
23	40 700 (5 900)	62 (143)	71 (160)	79 (175)	88 (191)	97 (207)	106 (223)	On
24	42 100 (6 100)	63 (146)	73 (163)	82 (179)	91 (196)	101 (213)	109 (229)	On
25	42 700 (6 195)	63 (146)	73 (163)	82 (179)	91 (196)	101 (213)	109 (229)	On
26	43 400 (6 290)	63 (146)	73 (163)	82 (179)	91 (196)	101 (213)	109 (229)	On
27	44 000 (6 385)	63 (146)	73 (163)	82 (179)	91 (196)	101 (213)	109 (229)	On
28	44 700 (6 480)	63 (146)	73 (163)	82 (179)	91 (196)	101 (213)	109 (229)	On
29	45 300 (6 575)	63 (146)	73 (163)	82 (179)	91 (196)	101 (213)	109 (229)	On
30	46 000 (6 670)	63 (146)	73 (163)	82 (179)	91 (196)	101 (213)	109 (229)	On
31	46 600 (6 765)	63 (146)	73 (163)	82 (179)	91 (196)	101 (213)	109 (229)	On
32	47 300 (6 860)	63 (146)	73 (163)	82 (179)	91 (196)	101 (213)	109 (229)	On
33	48 000 (6 955)	63 (146)	73 (163)	82 (179)	91 (196)	101 (213)	109 (229)	On
34	48 600 (7 050)	63 (146)	73 (163)	82 (179)	91 (196)	101 (213)	109 (229)	On

Table E.4 (continued)

1	2	3	4	5	6	7	8	9
Time min	Pressure kPa (psi)	Temperature gradient, °C/100 m depth (°F/100 ft depth)						Stirring
		1,6 (0,9)	2,0 (1,1)	2,4 (1,3)	2,7 (1,5)	3,1 (1,7)	3,5 (1,9)	
		Temperature						
		°C (°F)	°C (°F)	°C (°F)	°C (°F)	°C (°F)	°C (°F)	
Depth: 3 050 m (10 000 ft)				Mud density: 1,38 kg/l (11,5 lbm/gal)				
35	49 300 (7 145)	63 (146)	73 (163)	82 (179)	91 (196)	101 (213)	109 (229)	On
36	49 900 (7 240)	63 (146)	73 (163)	82 (179)	91 (196)	101 (213)	109 (229)	On
37	50 600 (7 335)	63 (146)	73 (163)	82 (179)	91 (196)	101 (213)	109 (229)	On
38	51 200 (7 430)	63 (146)	73 (163)	82 (179)	91 (196)	101 (213)	109 (229)	On
39	51 900 (7 525)	63 (146)	73 (163)	82 (179)	91 (196)	101 (213)	109 (229)	On
40	52 500 (7 620)	63 (146)	73 (163)	82 (179)	91 (196)	101 (213)	109 (229)	On
41	53 200 (7 715)	63 (146)	73 (163)	82 (179)	91 (196)	101 (213)	109 (229)	On
42	53 800 (7 810)	63 (146)	73 (163)	82 (179)	91 (196)	101 (213)	109 (229)	On
43	54 500 (7 905)	63 (146)	73 (163)	82 (179)	91 (196)	101 (213)	109 (229)	On
44	55 200 (8 000)	63 (146)	73 (163)	82 (179)	91 (196)	101 (213)	109 (229)	On
45	55 800 (8 095)	63 (146)	73 (163)	82 (179)	91 (196)	101 (213)	109 (229)	Off
55	55 800 (8 095)	64 (148)	74 (165)	83 (181)	92 (198)	102 (215)	111 (231)	On
60	55 800 (8 095)	65 (149)	74 (166)	83 (182)	93 (199)	102 (216)	111 (232)	Off
70	55 800 (8 095)	66 (151)	76 (168)	84 (184)	94 (201)	103 (218)	112 (234)	On
75	55 800 (8 095)	67 (152)	76 (169)	85 (185)	94 (202)	104 (219)	113 (235)	Off
85	55 800 (8 095)	68 (154)	77 (171)	86 (187)	96 (204)	105 (221)	114 (237)	On
90	55 800 (8 095)	68 (155)	78 (172)	87 (188)	96 (205)	106 (222)	114 (238)	Off
100	55 800 (8 095)	69 (157)	79 (174)	88 (190)	97 (207)	107 (224)	116 (240)	On
105	55 800 (8 095)	70 (158)	79 (175)	88 (191)	98 (208)	107 (225)	116 (241)	Off
115	55 800 (8 095)	71 (160)	81 (177)	89 (193)	99 (210)	108 (227)	117 (243)	On
120	55 800 (8 095)	72 (161)	81 (178)	90 (194)	99 (211)	109 (228)	118 (244)	Off
130	55 800 (8 095)	73 (163)	82 (180)	91 (196)	101 (213)	110 (230)	119 (246)	On
135	55 800 (8 095)	73 (164)	83 (181)	92 (197)	101 (214)	111 (231)	119 (247)	Off
145	55 800 (8 095)	74 (166)	84 (183)	93 (199)	102 (216)	112 (233)	121 (249)	On
150	55 800 (8 095)	75 (167)	84 (184)	93 (200)	103 (217)	112 (234)	121 (250)	Off
160	55 800 (8 095)	76 (169)	86 (186)	94 (202)	104 (219)	113 (236)	122 (252)	On
165	55 800 (8 095)	77 (170)	86 (187)	95 (203)	104 (220)	114 (237)	123 (253)	Off
175	55 800 (8 095)	77 (170)	87 (189)	96 (205)	106 (222)	115 (239)	124 (255)	On
180	55 800 (8 095)	77 (170)	88 (190)	97 (206)	106 (223)	116 (240)	124 (256)	Off
190	55 800 (8 095)	77 (170)	88 (190)	98 (208)	107 (225)	117 (242)	126 (258)	On
195	55 800 (8 095)	77 (170)	88 (190)	98 (209)	108 (226)	117 (243)	126 (259)	Off
205	55 800 (8 095)	77 (170)	88 (190)	99 (210)	109 (228)	118 (245)	127 (261)	On
210	55 800 (8 095)	77 (170)	88 (190)	99 (210)	109 (229)	119 (246)	128 (262)	Off
220	55 800 (8 095)	77 (170)	88 (190)	99 (210)	110 (230)	120 (248)	129 (264)	On
225	55 800 (8 095)	77 (170)	88 (190)	99 (210)	110 (230)	121 (249)	129 (265)	Off

Table E.4 (continued)

1	2	3	4	5	6	7	8	9
Time min	Pressure kPa (psi)	Temperature gradient, °C/100 m depth (°F/100 ft depth)						Stirring
		1,6 (0,9)	2,0 (1,1)	2,4 (1,3)	2,7 (1,5)	3,1 (1,7)	3,5 (1,9)	
		Temperature						
		°C (°F)	°C (°F)	°C (°F)	°C (°F)	°C (°F)	°C (°F)	
Depth: 3 050 m (10 000 ft)				Mud density: 1,38 kg/l (11,5 lbm/gal)				
235	55 800 (8 095)	77 (170)	88 (190)	99 (210)	110 (230)	121 (250)	131 (267)	On
240	55 800 (8 095)	77 (170)	88 (190)	99 (210)	110 (230)	121 (250)	131 (268)	Off
250	55 800 (8 095)	77 (170)	88 (190)	99 (210)	110 (230)	121 (250)	132 (270)	On
255	55 800 (8 095)	77 (170)	88 (190)	99 (210)	110 (230)	121 (250)	132 (270)	Off
<b>Segment 1</b>								
Ramp (deg/min)		1,53 (2,75)	1,92 (3,46)	2,29 (4,13)	2,68 (4,63)	3,08 (5,54)	3,45 (6,21)	
Ramp time		24 min						
Temp. dwell		21 min						
Pressure rate (per min)		1 379 kPa (200 psi) for 24 min, then 652 kPa (95 psi) for 21 min						
<b>Segment 2</b>								
Ramp (deg/min)		0,11 (0,20)	0,11 (0,20)	0,11 (0,20)	0,11 (0,20)	0,11 (0,20)	0,11 (0,20)	
Ramp time		120 min	135 min	155 min	170 min	185 min	205 min	

Table E.4 (continued)

1	2	3	4	5	6	7	8	9
Time min	Pressure kPa (psi)	Temperature gradient, °C/100 m depth (°F/100 ft depth)						Stirring
		1,6 (0,9)	2,0 (1,1)	2,4 (1,3)	2,7 (1,5)	3,1 (1,7)	3,5 (1,9)	
		Temperature						
		°C (°F)	°C (°F)	°C (°F)	°C (°F)	°C (°F)	°C (°F)	
Depth: 3 660 m (12 000 ft)				Mud density: 1,49 kg/l (12,4 lbm/gal)				
0	10 300 (1 500)	27 (80)	27 (80)	27 (80)	27 (80)	27 (80)	27 (80)	On
1	11 900 (1 720)	28 (83)	29 (84)	29 (84)	29 (85)	30 (86)	30 (86)	On
2	13 400 (1 940)	30 (86)	31 (87)	31 (88)	32 (90)	33 (91)	34 (93)	On
3	14 900 (2 160)	31 (88)	33 (91)	34 (93)	35 (95)	36 (97)	37 (99)	On
4	16 400 (2 380)	33 (91)	34 (94)	36 (97)	38 (100)	39 (103)	41 (105)	On
5	17 900 (2 600)	34 (94)	37 (98)	38 (101)	41 (105)	42 (108)	44 (112)	On
6	19 400 (2 820)	36 (97)	38 (101)	41 (105)	43 (110)	46 (114)	48 (118)	On
7	21 000 (3 040)	38 (100)	41 (105)	43 (110)	46 (115)	49 (120)	51 (124)	On
8	22 500 (3 260)	39 (103)	42 (108)	46 (114)	48 (119)	52 (125)	55 (131)	On
9	24 000 (3 480)	41 (105)	44 (112)	48 (118)	51 (124)	55 (131)	58 (137)	On
10	25 500 (3 700)	42 (108)	47 (116)	50 (122)	54 (129)	58 (137)	62 (143)	On
11	27 000 (3 920)	44 (111)	48 (119)	53 (127)	57 (134)	61 (142)	66 (150)	On
12	28 500 (4 140)	46 (114)	51 (123)	55 (131)	59 (139)	64 (148)	69 (156)	On
13	30 100 (4 360)	47 (117)	52 (126)	57 (135)	62 (144)	68 (154)	72 (162)	On
14	31 600 (4 580)	49 (120)	54 (130)	59 (139)	65 (149)	71 (159)	76 (169)	On
15	33 100 (4 800)	50 (122)	56 (133)	62 (144)	68 (154)	74 (165)	79 (175)	On
16	34 600 (5 020)	52 (125)	58 (137)	64 (148)	71 (159)	77 (170)	83 (182)	On
17	36 100 (5 240)	53 (128)	60 (140)	67 (152)	73 (164)	80 (176)	87 (188)	On
18	37 600 (5 460)	55 (131)	62 (144)	69 (156)	76 (169)	83 (182)	90 (194)	On
19	39 200 (5 680)	57 (134)	64 (147)	72 (161)	79 (174)	86 (187)	94 (201)	On
20	40 700 (5 900)	58 (137)	66 (151)	74 (165)	82 (179)	89 (193)	97 (207)	On
21	42 200 (6 120)	59 (139)	68 (155)	76 (169)	84 (184)	93 (199)	101 (213)	On
22	43 700 (6 340)	61 (142)	70 (158)	78 (173)	87 (188)	96 (204)	104 (220)	On
23	45 200 (6 560)	63 (145)	72 (162)	81 (178)	89 (193)	99 (210)	108 (226)	On
24	46 700 (6 780)	64 (148)	74 (165)	83 (182)	92 (198)	102 (216)	111 (232)	On
25	48 300 (7 000)	66 (151)	76 (169)	86 (186)	95 (203)	105 (221)	115 (239)	On
26	49 800 (7 220)	68 (154)	78 (172)	88 (190)	98 (208)	108 (227)	118 (245)	On
27	51 300 (7 440)	69 (156)	80 (176)	91 (195)	101 (213)	112 (233)	122 (251)	On
28	52 800 (7 660)	71 (159)	82 (179)	93 (199)	103 (218)	114 (238)	126 (258)	On
29	54 300 (7 880)	72 (162)	84 (183)	95 (203)	106 (223)	118 (244)	129 (264)	On
30	55 100 (7 985)	72 (162)	84 (183)	95 (203)	106 (223)	118 (244)	129 (264)	On
31	55 800 (8 090)	72 (162)	84 (183)	95 (203)	106 (223)	118 (244)	129 (264)	On
32	56 500 (8 195)	72 (162)	84 (183)	95 (203)	106 (223)	118 (244)	129 (264)	On
33	57 200 (8 300)	72 (162)	84 (183)	95 (203)	106 (223)	118 (244)	129 (264)	On
34	58 000 (8 405)	72 (162)	84 (183)	95 (203)	106 (223)	118 (244)	129 (264)	On

Table E.4 (continued)

1	2	3	4	5	6	7	8	9
Time min	Pressure kPa (psi)	Temperature gradient, °C/100 m depth (°F/100 ft depth)						Stirring
		1,6 (0,9)	2,0 (1,1)	2,4 (1,3)	2,7 (1,5)	3,1 (1,7)	3,5 (1,9)	
		Temperature						
°C (°F)			°C (°F)		°C (°F)		°C (°F)	
Depth: 3 660 m (12 000 ft)				Mud density: 1,49 kg/l (12,4 lbm/gal)				
35	58 700 (8 510)	72 (162)	84 (183)	95 (203)	106 (223)	118 (244)	129 (264)	On
36	59 400 (8 615)	72 (162)	84 (183)	95 (203)	106 (223)	118 (244)	129 (264)	On
37	60 100 (8 720)	72 (162)	84 (183)	95 (203)	106 (223)	118 (244)	129 (264)	On
38	60 800 (8 825)	72 (162)	84 (183)	95 (203)	106 (223)	118 (244)	129 (264)	On
39	61 600 (8 930)	72 (162)	84 (183)	95 (203)	106 (223)	118 (244)	129 (264)	On
40	62 300 (9 035)	72 (162)	84 (183)	95 (203)	106 (223)	118 (244)	129 (264)	On
41	63 000 (9 140)	72 (162)	84 (183)	95 (203)	106 (223)	118 (244)	129 (264)	On
42	63 700 (9 245)	72 (162)	84 (183)	95 (203)	106 (223)	118 (244)	129 (264)	On
43	64 500 (9 350)	72 (162)	84 (183)	95 (203)	106 (223)	118 (244)	129 (264)	On
44	65 200 (9 455)	72 (162)	84 (183)	95 (203)	106 (223)	118 (244)	129 (264)	On
45	65 900 (9 560)	72 (162)	84 (183)	95 (203)	106 (223)	118 (244)	129 (264)	On
46	66 600 (9 665)	72 (162)	84 (183)	95 (203)	106 (223)	118 (244)	129 (264)	On
47	67 400 (9 770)	72 (162)	84 (183)	95 (203)	106 (223)	118 (244)	129 (264)	On
48	68 100 (9 875)	72 (162)	84 (183)	95 (203)	106 (223)	118 (244)	129 (264)	On
49	68 800 (9 980)	72 (162)	84 (183)	95 (203)	106 (223)	118 (244)	129 (264)	On
50	69 500 (10 085)	72 (162)	84 (183)	95 (203)	106 (223)	118 (244)	129 (264)	Off
60	69 500 (10 085)	73 (164)	85 (185)	96 (205)	107 (225)	119 (246)	130 (266)	On
65	69 500 (10 085)	74 (165)	86 (186)	97 (206)	108 (226)	119 (247)	131 (267)	Off
75	69 500 (10 085)	75 (167)	87 (188)	98 (208)	109 (228)	121 (249)	132 (269)	On
80	69 500 (10 085)	76 (168)	87 (189)	98 (209)	109 (229)	121 (250)	132 (270)	Off
90	69 500 (10 085)	77 (170)	88 (191)	99 (211)	111 (231)	122 (252)	133 (272)	On
95	69 500 (10 085)	77 (171)	89 (192)	100 (212)	111 (232)	123 (253)	134 (273)	Off
105	69 500 (10 085)	78 (173)	90 (194)	101 (214)	112 (234)	124 (255)	135 (275)	On
110	69 500 (10 085)	79 (174)	91 (195)	102 (215)	113 (235)	124 (256)	136 (276)	Off
120	69 500 (10 085)	80 (176)	92 (197)	103 (217)	114 (237)	126 (258)	137 (278)	On
125	69 500 (10 085)	81 (177)	92 (198)	103 (218)	114 (238)	126 (259)	137 (279)	Off
135	69 500 (10 085)	82 (179)	93 (200)	104 (220)	116 (240)	127 (261)	138 (281)	On
140	69 500 (10 085)	82 (180)	94 (201)	105 (221)	116 (241)	128 (262)	139 (282)	Off
150	69 500 (10 085)	83 (182)	95 (203)	106 (223)	117 (243)	129 (264)	140 (284)	On
155	69 500 (10 085)	84 (183)	96 (204)	107 (224)	118 (244)	129 (265)	141 (285)	Off
165	69 500 (10 085)	85 (185)	97 (206)	108 (226)	119 (246)	131 (267)	142 (287)	On
170	69 500 (10 085)	86 (186)	97 (207)	108 (227)	119 (247)	131 (268)	142 (288)	Off
180	69 500 (10 085)	87 (188)	98 (209)	109 (229)	121 (249)	132 (270)	143 (290)	On
185	69 500 (10 085)	87 (188)	99 (210)	110 (230)	121 (250)	133 (271)	144 (291)	Off
195	69 500 (10 085)	87 (188)	100 (212)	111 (232)	122 (252)	134 (273)	145 (293)	On

Table E.4 (continued)

1	2	3	4	5	6	7	8	9
Time min	Pressure kPa (psi)	Temperature gradient, °C/100 m depth (°F/100 ft depth)						Stirring
		1,6 (0,9)	2,0 (1,1)	2,4 (1,3)	2,7 (1,5)	3,1 (1,7)	3,5 (1,9)	
		Temperature						
		°C (°F)	°C (°F)	°C (°F)	°C (°F)	°C (°F)	°C (°F)	
Depth: 3 660 m (12 000 ft)				Mud density: 1,49 kg/l (12,4 lbm/gal)				
200	69 500 (10 085)	87 (188)	100 (212)	112 (233)	123 (253)	134 (274)	146 (294)	Off
210	69 500 (10 085)	87 (188)	100 (212)	113 (235)	124 (255)	136 (276)	147 (296)	On
215	69 500 (10 085)	87 (188)	100 (212)	113 (236)	124 (256)	136 (277)	147 (297)	Off
225	69 500 (10 085)	87 (188)	100 (212)	113 (236)	126 (258)	137 (279)	148 (299)	On
230	69 500 (10 085)	87 (188)	100 (212)	113 (236)	126 (259)	138 (280)	149 (300)	Off
240	69 500 (10 085)	87 (188)	100 (212)	113 (236)	127 (260)	139 (282)	150 (302)	On
245	69 500 (10 085)	87 (188)	100 (212)	113 (236)	127 (260)	139 (283)	151 (303)	Off
255	69 500 (10 085)	87 (188)	100 (212)	113 (236)	127 (260)	140 (284)	152 (305)	On
260	69 500 (10 085)	87 (188)	100 (212)	113 (236)	127 (260)	140 (284)	152 (306)	Off
270	69 500 (10 085)	87 (188)	100 (212)	113 (236)	127 (260)	140 (284)	153 (308)	On
275	69 500 (10 085)	87 (188)	100 (212)	113 (236)	127 (260)	140 (284)	153 (308)	Off
<b>Segment 1</b>								
Ramp (deg/min)		1,57 (2,83)	1,97 (3,55)	2,36 (4,24)	2,74 (4,93)	3,14 (5,66)	3,52 (6,34)	
Ramp time		29 min						
Temp. dwell		21 min						
Pressure rate (per min)		1 517 kPa (220 psi) for 29 min, then 724 kPa (105 psi) for 21 min						
<b>Segment 2</b>								
Ramp (deg/min)		0,11 (0,20)	0,11 (0,20)	0,11 (0,20)	0,11 (0,20)	0,11 (0,20)	0,11 (0,20)	
Ramp time		130 min	145 min	165 min	185 min	200 min	220 min	

Table E.4 (continued)

1	2	3	4	5	6	7	8	9
Time min	Pressure kPa (psi)	Temperature gradient, °C/100 m depth (°F/100 ft depth)						Stirring
		1,6 (0,9)	2,0 (1,1)	2,4 (1,3)	2,7 (1,5)	3,1 (1,7)	3,5 (1,9)	
		Temperature						
		°C (°F)	°C (°F)	°C (°F)	°C (°F)	°C (°F)	°C (°F)	
Depth: 4 270 m (14 000 ft)				Mud density: 1,59 kg/l (13,3 lbm/gal)				
0	12 400 (1 800)	27 (80)	27 (80)	27 (80)	27 (80)	27 (80)	27 (80)	On
1	14 000 (2 035)	28 (83)	29 (84)	29 (84)	29 (85)	30 (86)	30 (86)	On
2	15 700 (2 270)	30 (86)	31 (87)	32 (89)	32 (90)	33 (92)	34 (93)	On
3	17 300 (2 505)	32 (89)	33 (91)	34 (93)	35 (95)	36 (97)	37 (99)	On
4	18 900 (2 740)	33 (92)	35 (95)	36 (97)	38 (100)	39 (103)	41 (106)	On
5	20 500 (2 975)	35 (95)	37 (98)	39 (102)	41 (105)	43 (109)	44 (112)	On
6	22 100 (3 210)	36 (97)	39 (102)	41 (106)	43 (110)	46 (115)	48 (119)	On
7	23 800 (3 445)	38 (100)	41 (106)	43 (110)	46 (115)	49 (120)	52 (125)	On
8	25 400 (3 680)	39 (103)	43 (109)	46 (115)	49 (120)	52 (126)	56 (132)	On
9	27 000 (3 915)	41 (106)	45 (113)	48 (119)	52 (126)	56 (132)	59 (138)	On
10	28 600 (4 150)	43 (109)	47 (116)	51 (124)	55 (131)	59 (138)	63 (145)	On
11	30 200 (4 385)	44 (112)	49 (120)	53 (128)	58 (136)	62 (143)	66 (151)	On
12	31 900 (4 620)	46 (115)	51 (124)	56 (132)	61 (141)	65 (149)	70 (158)	On
13	33 500 (4 855)	48 (118)	53 (127)	58 (137)	63 (146)	68 (155)	73 (164)	On
14	35 100 (5 090)	49 (121)	55 (131)	61 (141)	66 (151)	72 (161)	77 (171)	On
15	36 700 (5 325)	51 (124)	57 (135)	63 (145)	69 (156)	74 (166)	81 (177)	On
16	38 300 (5 560)	53 (127)	59 (138)	66 (150)	72 (161)	78 (172)	84 (184)	On
17	40 000 (5 795)	54 (130)	61 (142)	68 (154)	74 (166)	81 (178)	88 (190)	On
18	41 600 (6 030)	56 (132)	63 (146)	70 (158)	77 (171)	84 (184)	91 (196)	On
19	43 200 (6 265)	57 (135)	65 (149)	73 (163)	80 (176)	88 (190)	95 (203)	On
20	44 800 (6 500)	59 (138)	67 (153)	75 (167)	83 (181)	91 (195)	98 (209)	On
21	46 400 (6 735)	61 (141)	69 (157)	77 (171)	86 (186)	94 (201)	102 (216)	On
22	48 100 (6 970)	62 (144)	71 (160)	80 (176)	88 (191)	97 (207)	106 (222)	On
23	49 700 (7 205)	64 (147)	73 (164)	82 (180)	91 (196)	101 (213)	109 (229)	On
24	51 300 (7 440)	66 (150)	76 (168)	84 (184)	94 (201)	103 (218)	113 (235)	On
25	52 900 (7 675)	67 (153)	77 (171)	87 (189)	97 (206)	107 (224)	117 (242)	On
26	54 500 (7 910)	69 (156)	79 (175)	89 (193)	100 (212)	110 (230)	120 (248)	On
27	56 200 (8 145)	71 (159)	81 (178)	92 (198)	103 (217)	113 (236)	124 (255)	On
28	57 800 (8 380)	72 (162)	83 (182)	94 (202)	106 (222)	116 (241)	127 (261)	On
29	59 400 (8 615)	73 (164)	86 (186)	97 (206)	108 (227)	119 (247)	131 (268)	On
30	61 000 (8 850)	75 (167)	87 (189)	99 (211)	111 (232)	123 (253)	134 (274)	On
31	62 600 (9 085)	77 (170)	89 (193)	102 (215)	114 (237)	126 (259)	138 (281)	On
32	64 300 (9 320)	78 (173)	92 (197)	104 (219)	117 (242)	129 (264)	142 (287)	On
33	65 900 (9 555)	80 (176)	93 (200)	107 (224)	119 (247)	132 (270)	146 (294)	On
34	67 500 (9 790)	82 (179)	96 (204)	109 (228)	122 (252)	136 (276)	149 (300)	On



Table E.4 (continued)

1	2	3	4	5	6	7	8	9
Time min	Pressure kPa (psi)	Temperature gradient, °C/100 m depth (°F/100 ft depth)						Stirring
		1,6 (0,9)	2,0 (1,1)	2,4 (1,3)	2,7 (1,5)	3,1 (1,7)	3,5 (1,9)	
		Temperature						
		°C (°F)	°C (°F)	°C (°F)	°C (°F)	°C (°F)	°C (°F)	
Depth: 4 270 m (14 000 ft)				Mud density: 1,59 kg/l (13,3 lbm/gal)				
35	68 200 (9 895)	82 (179)	96 (204)	109 (228)	122 (252)	136 (276)	149 (300)	On
36	69 000 (10 000)	82 (179)	96 (204)	109 (228)	122 (252)	136 (276)	149 (300)	On
37	69 700 (10 105)	82 (179)	96 (204)	109 (228)	122 (252)	136 (276)	149 (300)	On
38	70 400 (10 210)	82 (179)	96 (204)	109 (228)	122 (252)	136 (276)	149 (300)	On
39	71 100 (10 315)	82 (179)	96 (204)	109 (228)	122 (252)	136 (276)	149 (300)	On
40	71 800 (10 420)	82 (179)	96 (204)	109 (228)	122 (252)	136 (276)	149 (300)	On
41	72 600 (10 525)	82 (179)	96 (204)	109 (228)	122 (252)	136 (276)	149 (300)	On
42	73 300 (10 630)	82 (179)	96 (204)	109 (228)	122 (252)	136 (276)	149 (300)	On
43	74 000 (10 735)	82 (179)	96 (204)	109 (228)	122 (252)	136 (276)	149 (300)	On
44	74 700 (10 840)	82 (179)	96 (204)	109 (228)	122 (252)	136 (276)	149 (300)	On
45	75 500 (10 945)	82 (179)	96 (204)	109 (228)	122 (252)	136 (276)	149 (300)	On
46	76 200 (11 050)	82 (179)	96 (204)	109 (228)	122 (252)	136 (276)	149 (300)	On
47	76 900 (11 155)	82 (179)	96 (204)	109 (228)	122 (252)	136 (276)	149 (300)	On
48	77 600 (11 260)	82 (179)	96 (204)	109 (228)	122 (252)	136 (276)	149 (300)	On
49	78 400 (11 365)	82 (179)	96 (204)	109 (228)	122 (252)	136 (276)	149 (300)	On
50	79 100 (11 470)	82 (179)	96 (204)	109 (228)	122 (252)	136 (276)	149 (300)	On
51	79 800 (11 575)	82 (179)	96 (204)	109 (228)	122 (252)	136 (276)	149 (300)	On
52	80 500 (11 680)	82 (179)	96 (204)	109 (228)	122 (252)	136 (276)	149 (300)	On
53	81 300 (11 785)	82 (179)	96 (204)	109 (228)	122 (252)	136 (276)	149 (300)	On
54	82 000 (11 890)	82 (179)	96 (204)	109 (228)	122 (252)	136 (276)	149 (300)	On
55	82 700 (11 995)	82 (179)	96 (204)	109 (228)	122 (252)	136 (276)	149 (300)	Off
65	82 700 (11 995)	83 (181)	97 (206)	110 (230)	123 (254)	137 (278)	150 (302)	On
70	82 700 (11 995)	83 (182)	97 (207)	111 (231)	124 (255)	137 (279)	151 (303)	Off
80	82 700 (11 995)	84 (184)	98 (209)	112 (233)	125 (257)	138 (281)	152 (305)	On
85	82 700 (11 995)	85 (185)	99 (210)	112 (234)	126 (258)	139 (282)	152 (306)	Off
95	82 700 (11 995)	86 (187)	100 (212)	113 (236)	127 (260)	140 (284)	153 (308)	On
100	82 700 (11 995)	87 (188)	101 (213)	114 (237)	127 (261)	141 (285)	154 (309)	Off
110	82 700 (11 995)	88 (190)	102 (215)	115 (239)	128 (263)	142 (287)	155 (311)	On
115	82 700 (11 995)	88 (191)	102 (216)	116 (240)	129 (264)	142 (288)	156 (312)	Off
125	82 700 (11 995)	89 (193)	103 (218)	117 (242)	130 (266)	143 (290)	157 (314)	On
130	82 700 (11 995)	90 (194)	104 (219)	117 (243)	131 (267)	144 (291)	157 (315)	Off
140	82 700 (11 995)	91 (196)	105 (221)	118 (245)	132 (269)	145 (293)	158 (317)	On
145	82 700 (11 995)	92 (197)	106 (222)	119 (246)	132 (270)	146 (294)	159 (318)	Off
155	82 700 (11 995)	93 (199)	107 (224)	120 (248)	133 (272)	147 (296)	160 (320)	On
160	82 700 (11 995)	93 (200)	107 (225)	121 (249)	134 (273)	147 (297)	161 (321)	Off

Table E.4 (continued)

1	2	3	4	5	6	7	8	9
Time min	Pressure kPa (psi)	Temperature gradient, °C/100 m depth (°F/100 ft depth)						Stirring
		1,6 (0,9)	2,0 (1,1)	2,4 (1,3)	2,7 (1,5)	3,1 (1,7)	3,5 (1,9)	
		Temperature						
		°C (°F)	°C (°F)	°C (°F)	°C (°F)	°C (°F)	°C (°F)	
Depth: 4 270 m (14 000 ft)				Mud density: 1,59 kg/l (13,3 lbm/gal)				
170	82 700 (11 995)	94 (202)	108 (227)	122 (251)	135 (275)	148 (299)	162 (323)	On
175	82 700 (11 995)	95 (203)	109 (228)	122 (252)	136 (276)	149 (300)	162 (324)	Off
185	82 700 (11 995)	96 (205)	110 (230)	123 (254)	137 (278)	150 (302)	163 (326)	On
190	82 700 (11 995)	97 (206)	111 (231)	124 (255)	137 (279)	151 (303)	164 (327)	Off
200	82 700 (11 995)	97 (206)	112 (233)	125 (257)	138 (281)	152 (305)	165 (329)	On
205	82 700 (11 995)	97 (206)	112 (234)	126 (258)	139 (282)	152 (306)	166 (330)	Off
215	82 700 (11 995)	97 (206)	112 (234)	127 (260)	140 (284)	153 (308)	167 (332)	On
220	82 700 (11 995)	97 (206)	112 (234)	127 (261)	141 (285)	154 (309)	167 (333)	Off
230	82 700 (11 995)	97 (206)	112 (234)	128 (262)	142 (287)	155 (311)	168 (335)	On
235	82 700 (11 995)	97 (206)	112 (234)	128 (262)	142 (288)	156 (312)	169 (336)	Off
245	82 700 (11 995)	97 (206)	112 (234)	128 (262)	143 (290)	157 (314)	170 (338)	On
250	82 700 (11 995)	97 (206)	112 (234)	128 (262)	143 (290)	157 (315)	171 (339)	Off
260	82 700 (11 995)	97 (206)	112 (234)	128 (262)	143 (290)	158 (317)	172 (341)	On
265	82 700 (11 995)	97 (206)	112 (234)	128 (262)	143 (290)	159 (318)	172 (342)	Off
275	82 700 (11 995)	97 (206)	112 (234)	128 (262)	143 (290)	159 (318)	173 (344)	On
280	82 700 (11 995)	97 (206)	112 (234)	128 (262)	143 (290)	159 (318)	174 (345)	Off
290	82 700 (11 995)	97 (206)	112 (234)	128 (262)	143 (290)	159 (318)	174 (346)	On
295	82 700 (11 995)	97 (206)	112 (234)	128 (262)	143 (290)	159 (318)	174 (346)	Off
<b>Segment 1</b>								
Ramp (deg/min)		1,62 (2,91)	2,03 (3,65)	2,42 (4,35)	2,81 (5,06)	3,20 (5,76)	3,59 (6,47)	
Ramp time		34 min						
Temp. dwell		21 min						
Pressure rate (per min)		1 621 kPa (235 psi) for 34 min, then 724 kPa (105 psi) for 21 min						
<b>Segment 2</b>								
Ramp (deg/min)		0,11 (0,20)	0,11 (0,20)	0,11 (0,20)	0,11 (0,20)	0,11 (0,20)	0,11 (0,20)	
Ramp time		135 min	150 min	170 min	190 min	210 min	230 min	

Table E.4 (continued)

1	2	3	4	5	6	7	8	9
Time min	Pressure kPa (psi)	Temperature gradient, °C/100 m depth (°F/100 ft depth)						Stirring
		1,6 (0,9)	2,0 (1,1)	2,4 (1,3)	2,7 (1,5)	3,1 (1,7)	3,5 (1,9)	
		Temperature						
		°C (°F)	°C (°F)	°C (°F)	°C (°F)	°C (°F)	°C (°F)	
Depth: 4 880 m (16 000 ft)				Mud density: 1,73 kg/l (14,4 lbm/gal)				
0	13 800 (2 000)	27 (80)	27 (80)	27 (80)	27 (80)	27 (80)	27 (80)	On
1	15 500 (2 255)	28 (83)	29 (84)	29 (84)	29 (85)	30 (86)	31 (87)	On
2	17 300 (2 510)	30 (86)	31 (87)	32 (89)	32 (90)	33 (92)	34 (93)	On
3	19 100 (2 765)	32 (89)	33 (91)	34 (93)	35 (95)	37 (98)	38 (100)	On
4	20 800 (3 020)	33 (92)	35 (95)	37 (98)	38 (101)	39 (103)	41 (106)	On
5	22 600 (3 275)	35 (95)	37 (99)	39 (102)	41 (106)	43 (109)	45 (113)	On
6	24 300 (3 530)	37 (98)	39 (102)	42 (107)	44 (111)	46 (115)	49 (120)	On
7	26 100 (3 785)	38 (101)	41 (106)	44 (111)	47 (116)	49 (121)	52 (126)	On
8	27 900 (4 040)	40 (104)	43 (110)	46 (115)	49 (121)	53 (127)	56 (133)	On
9	29 600 (4 295)	42 (107)	45 (113)	49 (120)	52 (126)	56 (133)	60 (140)	On
10	31 400 (4 550)	43 (110)	47 (117)	51 (124)	56 (132)	59 (139)	63 (146)	On
11	33 100 (4 805)	45 (113)	49 (121)	54 (129)	58 (137)	63 (145)	67 (153)	On
12	34 900 (5 060)	47 (116)	52 (125)	56 (133)	61 (142)	66 (150)	71 (159)	On
13	36 600 (5 315)	48 (119)	53 (128)	59 (138)	64 (147)	69 (156)	74 (166)	On
14	38 400 (5 570)	50 (122)	56 (132)	61 (142)	67 (152)	72 (162)	78 (173)	On
15	40 200 (5 825)	52 (125)	58 (136)	64 (147)	69 (157)	76 (168)	82 (179)	On
16	41 900 (6 080)	53 (128)	59 (139)	66 (151)	72 (162)	79 (174)	86 (186)	On
17	43 700 (6 335)	55 (131)	62 (143)	68 (155)	76 (168)	82 (180)	89 (192)	On
18	45 400 (6 590)	57 (134)	64 (147)	71 (160)	78 (173)	86 (186)	93 (199)	On
19	47 200 (6 845)	58 (137)	66 (151)	73 (164)	81 (178)	89 (192)	97 (206)	On
20	49 000 (7 100)	60 (140)	68 (154)	76 (169)	84 (183)	92 (197)	100 (212)	On
21	50 700 (7 355)	62 (143)	70 (158)	78 (173)	87 (188)	95 (203)	104 (219)	On
22	52 500 (7 610)	63 (146)	72 (162)	81 (178)	89 (193)	98 (209)	108 (226)	On
23	54 200 (7 865)	65 (149)	74 (166)	83 (182)	93 (199)	102 (215)	111 (232)	On
24	56 000 (8 120)	67 (152)	76 (169)	86 (186)	96 (204)	105 (221)	115 (239)	On
25	57 700 (8 375)	68 (155)	78 (173)	88 (191)	98 (209)	108 (227)	118 (245)	On
26	59 500 (8 630)	70 (158)	81 (177)	91 (195)	101 (214)	112 (233)	122 (252)	On
27	61 300 (8 885)	72 (161)	82 (180)	93 (200)	104 (219)	115 (239)	126 (259)	On
28	63 000 (9 140)	73 (164)	84 (184)	96 (204)	107 (224)	118 (244)	129 (265)	On
29	64 800 (9 395)	75 (167)	87 (188)	98 (209)	109 (229)	121 (250)	133 (272)	On
30	66 500 (9 650)	77 (170)	89 (192)	101 (213)	113 (235)	124 (256)	137 (278)	On
31	68 300 (9 905)	78 (173)	91 (195)	103 (218)	116 (240)	128 (262)	141 (285)	On
32	70 100 (10 160)	80 (176)	93 (199)	106 (222)	118 (245)	131 (268)	144 (292)	On
33	71 800 (10 415)	82 (179)	95 (203)	108 (226)	121 (250)	134 (274)	148 (298)	On
34	73 600 (10 670)	83 (182)	97 (206)	111 (231)	124 (255)	138 (280)	152 (305)	On

Table E.4 (continued)

1	2	3	4	5	6	7	8	9
Time min	Pressure kPa (psi)	Temperature gradient, °C/100 m depth (°F/100 ft depth)						Stirring
		1,6 (0,9)	2,0 (1,1)	2,4 (1,3)	2,7 (1,5)	3,1 (1,7)	3,5 (1,9)	
		Temperature						
		°C (°F)	°C (°F)	°C (°F)	°C (°F)	°C (°F)	°C (°F)	
Depth: 4 880 m (16 000 ft)				Mud density: 1,73 kg/l (14,4 lbm/gal)				
35	75 300 (10 925)	85 (185)	99 (210)	113 (235)	127 (260)	141 (286)	156 (312)	On
36	77 100 (11 180)	87 (188)	101 (214)	116 (240)	130 (266)	144 (291)	159 (318)	On
37	78 800 (11 435)	88 (191)	103 (218)	118 (244)	133 (271)	147 (297)	163 (325)	On
38	80 600 (11 690)	90 (194)	105 (221)	121 (249)	136 (276)	151 (303)	166 (331)	On
39	82 400 (11 945)	92 (197)	107 (225)	123 (253)	138 (281)	154 (309)	170 (338)	On
40	83 300 (12 085)	92 (197)	107 (225)	123 (253)	138 (281)	154 (309)	170 (338)	On
41	84 300 (12 225)	92 (197)	107 (225)	123 (253)	138 (281)	154 (309)	170 (338)	On
42	85 300 (12 365)	92 (197)	107 (225)	123 (253)	138 (281)	154 (309)	170 (338)	On
43	86 200 (12 505)	92 (197)	107 (225)	123 (253)	138 (281)	154 (309)	170 (338)	On
44	87 200 (12 645)	92 (197)	107 (225)	123 (253)	138 (281)	154 (309)	170 (338)	On
45	88 200 (12 785)	92 (197)	107 (225)	123 (253)	138 (281)	154 (309)	170 (338)	On
46	89 100 (12 925)	92 (197)	107 (225)	123 (253)	138 (281)	154 (309)	170 (338)	On
47	90 100 (13 065)	92 (197)	107 (225)	123 (253)	138 (281)	154 (309)	170 (338)	On
48	91 000 (13 205)	92 (197)	107 (225)	123 (253)	138 (281)	154 (309)	170 (338)	On
49	92 000 (13 345)	92 (197)	107 (225)	123 (253)	138 (281)	154 (309)	170 (338)	On
50	93 000 (13 485)	92 (197)	107 (225)	123 (253)	138 (281)	154 (309)	170 (338)	On
51	93 900 (13 625)	92 (197)	107 (225)	123 (253)	138 (281)	154 (309)	170 (338)	On
52	94 900 (13 765)	92 (197)	107 (225)	123 (253)	138 (281)	154 (309)	170 (338)	On
53	95 900 (13 905)	92 (197)	107 (225)	123 (253)	138 (281)	154 (309)	170 (338)	On
54	96 800 (14 045)	92 (197)	107 (225)	123 (253)	138 (281)	154 (309)	170 (338)	On
55	97 800 (14 185)	92 (197)	107 (225)	123 (253)	138 (281)	154 (309)	170 (338)	Off
65	97 800 (14 185)	93 (199)	108 (227)	124 (255)	139 (283)	155 (311)	171 (340)	On
70	97 800 (14 185)	93 (200)	109 (228)	124 (256)	140 (284)	156 (312)	172 (341)	Off
80	97 800 (14 185)	94 (202)	110 (230)	126 (258)	141 (286)	157 (314)	173 (343)	On
85	97 800 (14 185)	95 (203)	111 (231)	126 (259)	142 (287)	157 (315)	173 (344)	Off
95	97 800 (14 185)	96 (205)	112 (233)	127 (261)	143 (289)	158 (317)	174 (346)	On
100	97 800 (14 185)	97 (206)	112 (234)	128 (262)	143 (290)	159 (318)	175 (347)	Off
110	97 800 (14 185)	98 (208)	113 (236)	129 (264)	144 (292)	160 (320)	176 (349)	On
115	97 800 (14 185)	98 (209)	114 (237)	129 (265)	145 (293)	161 (321)	177 (350)	Off
125	97 800 (14 185)	99 (211)	115 (239)	131 (267)	146 (295)	162 (323)	178 (352)	On
130	97 800 (14 185)	100 (212)	116 (240)	131 (268)	147 (296)	162 (324)	178 (353)	Off
140	97 800 (14 185)	101 (214)	117 (242)	132 (270)	148 (298)	163 (326)	179 (355)	On
145	97 800 (14 185)	102 (215)	117 (243)	133 (271)	148 (299)	164 (327)	180 (356)	Off
155	97 800 (14 185)	103 (217)	118 (245)	134 (273)	149 (301)	165 (329)	181 (358)	On
160	97 800 (14 185)	103 (218)	119 (246)	134 (274)	150 (302)	166 (330)	182 (359)	Off

Table E.4 (continued)

1	2	3	4	5	6	7	8	9
Time min	Pressure kPa (psi)	Temperature gradient, °C/100 m depth (°F/100 ft depth)						Stirring
		1,6 (0,9)	2,0 (1,1)	2,4 (1,3)	2,7 (1,5)	3,1 (1,7)	3,5 (1,9)	
		Temperature						
		°C (°F)	°C (°F)	°C (°F)	°C (°F)	°C (°F)	°C (°F)	
Depth: 4 880 m (16 000 ft)				Mud density: 1,73 kg/l (14,4 lbm/gal)				
170	97 800 (14 185)	104 (220)	120 (248)	136 (276)	151 (304)	167 (332)	183 (361)	On
175	97 800 (14 185)	105 (221)	121 (249)	136 (277)	152 (305)	167 (333)	183 (362)	Off
185	97 800 (14 185)	106 (223)	122 (251)	137 (279)	153 (307)	168 (335)	184 (364)	On
190	97 800 (14 185)	107 (224)	122 (252)	138 (280)	153 (308)	169 (336)	185 (365)	Off
200	97 800 (14 185)	107 (224)	123 (254)	139 (282)	154 (310)	170 (338)	186 (367)	On
205	97 800 (14 185)	107 (224)	124 (255)	139 (283)	155 (311)	171 (339)	187 (368)	Off
215	97 800 (14 185)	107 (224)	124 (256)	141 (285)	156 (313)	172 (341)	188 (370)	On
220	97 800 (14 185)	107 (224)	124 (256)	141 (286)	157 (314)	172 (342)	188 (371)	Off
230	97 800 (14 185)	107 (224)	124 (256)	142 (288)	158 (316)	173 (344)	189 (373)	On
235	97 800 (14 185)	107 (224)	124 (256)	142 (288)	158 (317)	174 (345)	190 (374)	Off
245	97 800 (14 185)	107 (224)	124 (256)	142 (288)	159 (319)	175 (347)	191 (376)	On
250	97 800 (14 185)	107 (224)	124 (256)	142 (288)	160 (320)	176 (348)	192 (377)	Off
260	97 800 (14 185)	107 (224)	124 (256)	142 (288)	160 (320)	177 (350)	193 (379)	On
265	97 800 (14 185)	107 (224)	124 (256)	142 (288)	160 (320)	177 (351)	193 (380)	Off
275	97 800 (14 185)	107 (224)	124 (256)	142 (288)	160 (320)	178 (352)	194 (382)	On
280	97 800 (14 185)	107 (224)	124 (256)	142 (288)	160 (320)	178 (352)	195 (383)	Off
290	97 800 (14 185)	107 (224)	124 (256)	142 (288)	160 (320)	178 (352)	196 (384)	On
295	97 800 (14 185)	107 (224)	124 (256)	142 (288)	160 (320)	178 (352)	196 (384)	Off
<b>Segment 1</b>								
Ramp (deg/min)		1,67 (3,00)	2,07 (3,72)	2,47 (4,44)	2,86 (5,15)	3,26 (5,87)	3,68 (6,62)	
Ramp time		39 min						
Temp. dwell		16 min						
Pressure rate (per min)		1 759 kPa (255 psi) for 39 min, then 963 kPa (140 psi) for 16 min						
<b>Segment 2</b>								
Ramp (deg/min)		0,11 (0,20)	0,11 (0,20)	0,11 (0,20)	0,11 (0,20)	0,11 (0,20)	0,11 (0,20)	
Ramp time		135 min	155 min	175 min	195 min	215 min	230 min	

Table E.4 (continued)

1	2	3	4	5	6	7	8	9
Time  min	Pressure  kPa (psi)	Temperature gradient, °C/100 m depth (°F/100 ft depth)						Stirring
		1,6 (0,9)	2,0 (1,1)	2,4 (1,3)	2,7 (1,5)	3,1 (1,7)	3,5 (1,9)	
		Temperature						
		°C (°F)	°C (°F)	°C (°F)	°C (°F)	°C (°F)	°C (°F)	
Depth: 5 490 m (18 000 ft)				Mud density: 1,87 kg/l (15,6 lbm/gal)				
0	15 200 (2 200)	27 (80)	27 (80)	27 (80)	27 (80)	27 (80)	27 (80)	On
1	17 100 (2 475)	28 (83)	29 (84)	29 (85)	29 (85)	30 (86)	31 (87)	On
2	19 000 (2 750)	30 (86)	31 (88)	32 (89)	33 (91)	33 (92)	34 (93)	On
3	20 900 (3 025)	32 (89)	33 (91)	34 (94)	36 (96)	37 (98)	38 (100)	On
4	22 800 (3 300)	33 (92)	35 (95)	37 (98)	38 (101)	40 (104)	42 (107)	On
5	24 600 (3 575)	35 (95)	37 (99)	39 (103)	41 (106)	43 (110)	46 (114)	On
6	26 500 (3 850)	37 (98)	39 (103)	42 (107)	44 (112)	47 (116)	49 (120)	On
7	28 400 (4 125)	38 (101)	42 (107)	44 (112)	47 (117)	50 (122)	53 (127)	On
8	30 300 (4 400)	41 (105)	44 (111)	47 (116)	50 (122)	53 (128)	57 (134)	On
9	32 200 (4 675)	42 (108)	46 (114)	49 (121)	53 (127)	57 (134)	61 (141)	On
10	34 100 (4 950)	44 (111)	48 (118)	52 (125)	56 (133)	60 (140)	64 (147)	On
11	36 000 (5 225)	46 (114)	50 (122)	54 (130)	59 (138)	63 (146)	68 (154)	On
12	37 900 (5 500)	47 (117)	52 (126)	57 (135)	62 (143)	67 (152)	72 (161)	On
13	39 800 (5 775)	49 (120)	54 (130)	59 (139)	65 (149)	70 (158)	75 (167)	On
14	41 700 (6 050)	51 (123)	56 (133)	62 (144)	68 (154)	73 (164)	79 (174)	On
15	43 600 (6 325)	52 (126)	58 (137)	64 (148)	71 (159)	77 (170)	83 (181)	On
16	45 500 (6 600)	54 (129)	61 (141)	67 (153)	73 (164)	80 (176)	87 (188)	On
17	47 400 (6 875)	56 (132)	63 (145)	69 (157)	77 (170)	83 (182)	90 (194)	On
18	49 300 (7 150)	57 (135)	65 (149)	72 (162)	79 (175)	87 (188)	94 (201)	On
19	51 200 (7 425)	59 (138)	67 (153)	74 (166)	82 (180)	90 (194)	98 (208)	On
20	53 100 (7 700)	61 (141)	69 (156)	77 (171)	85 (185)	93 (200)	102 (215)	On
21	55 000 (7 975)	62 (144)	71 (160)	79 (175)	88 (191)	97 (206)	105 (221)	On
22	56 900 (8 250)	64 (148)	73 (164)	82 (180)	91 (196)	100 (212)	109 (228)	On
23	58 800 (8 525)	66 (151)	76 (168)	85 (185)	94 (201)	103 (218)	113 (235)	On
24	60 700 (8 800)	68 (154)	78 (172)	87 (189)	97 (207)	107 (224)	116 (241)	On
25	62 600 (9 075)	69 (157)	79 (175)	90 (194)	100 (212)	110 (230)	120 (248)	On
26	64 500 (9 350)	71 (160)	82 (179)	92 (198)	103 (217)	113 (236)	124 (255)	On
27	66 400 (9 625)	73 (163)	84 (183)	95 (203)	106 (222)	117 (242)	128 (262)	On
28	68 300 (9 900)	74 (166)	86 (187)	97 (207)	109 (228)	120 (248)	131 (268)	On
29	70 200 (10 175)	76 (169)	88 (191)	100 (212)	112 (233)	123 (254)	135 (275)	On
30	72 100 (10 450)	78 (172)	91 (195)	102 (216)	114 (238)	127 (260)	139 (282)	On
31	73 900 (10 725)	79 (175)	92 (198)	105 (221)	117 (243)	130 (266)	143 (289)	On
32	75 800 (11 000)	81 (178)	94 (202)	107 (225)	121 (249)	133 (272)	146 (295)	On
33	77 700 (11 275)	83 (181)	97 (206)	110 (230)	123 (254)	137 (278)	150 (302)	On
34	79 600 (11 550)	84 (184)	99 (210)	113 (235)	126 (259)	140 (284)	154 (309)	On

Table E.4 (continued)

1	2	3	4	5	6	7	8	9
Time min	Pressure kPa (psi)	Temperature gradient, °C/100 m depth (°F/100 ft depth)						Stirring
		1,6 (0,9)	2,0 (1,1)	2,4 (1,3)	2,7 (1,5)	3,1 (1,7)	3,5 (1,9)	
		Temperature						
		°C (°F)	°C (°F)	°C (°F)	°C (°F)	°C (°F)	°C (°F)	
Depth: 5 490 m (18 000 ft)				Mud density: 1,87 kg/l (15,6 lbm/gal)				
35	81 500 (11 825)	86 (187)	101 (214)	115 (239)	129 (265)	143 (290)	157 (315)	On
36	83 400 (12 100)	88 (190)	103 (217)	118 (244)	132 (270)	147 (296)	161 (322)	On
37	85 300 (12 375)	90 (194)	105 (221)	120 (248)	135 (275)	150 (302)	165 (329)	On
38	87 200 (12 650)	92 (197)	107 (225)	123 (253)	138 (280)	153 (308)	169 (336)	On
39	89 100 (12 925)	93 (200)	109 (229)	125 (257)	141 (286)	157 (314)	172 (342)	On
40	91 000 (13 200)	95 (203)	112 (233)	128 (262)	144 (291)	160 (320)	176 (349)	On
41	92 900 (13 475)	97 (206)	114 (237)	130 (266)	147 (296)	163 (326)	180 (356)	On
42	94 800 (13 750)	98 (209)	116 (240)	133 (271)	149 (301)	167 (332)	184 (363)	On
43	96 700 (14 025)	100 (212)	118 (244)	135 (275)	153 (307)	170 (338)	187 (369)	On
44	98 600 (14 300)	102 (215)	120 (248)	138 (280)	156 (312)	173 (344)	191 (376)	On
45	99 500 (14 435)	102 (215)	120 (248)	138 (280)	156 (312)	173 (344)	191 (376)	On
46	100 500 (14 570)	102 (215)	120 (248)	138 (280)	156 (312)	173 (344)	191 (376)	On
47	101 400 (14 705)	102 (215)	120 (248)	138 (280)	156 (312)	173 (344)	191 (376)	On
48	102 300 (14 840)	102 (215)	120 (248)	138 (280)	156 (312)	173 (344)	191 (376)	On
49	103 300 (14 975)	102 (215)	120 (248)	138 (280)	156 (312)	173 (344)	191 (376)	On
50	104 200 (15 110)	102 (215)	120 (248)	138 (280)	156 (312)	173 (344)	191 (376)	On
51	105 100 (15 245)	102 (215)	120 (248)	138 (280)	156 (312)	173 (344)	191 (376)	On
52	106 000 (15 380)	102 (215)	120 (248)	138 (280)	156 (312)	173 (344)	191 (376)	On
53	107 000 (15 515)	102 (215)	120 (248)	138 (280)	156 (312)	173 (344)	191 (376)	On
54	107 900 (15 650)	102 (215)	120 (248)	138 (280)	156 (312)	173 (344)	191 (376)	On
55	108 800 (15 785)	102 (215)	120 (248)	138 (280)	156 (312)	173 (344)	191 (376)	On
56	109 800 (15 920)	102 (215)	120 (248)	138 (280)	156 (312)	173 (344)	191 (376)	On
57	110 700 (16 055)	102 (215)	120 (248)	138 (280)	156 (312)	173 (344)	191 (376)	On
58	111 600 (16 190)	102 (215)	120 (248)	138 (280)	156 (312)	173 (344)	191 (376)	On
59	112 600 (16 325)	102 (215)	120 (248)	138 (280)	156 (312)	173 (344)	191 (376)	On
60	113 500 (16 460)	102 (215)	120 (248)	138 (280)	156 (312)	173 (344)	191 (376)	Off
70	113 500 (16 460)	103 (217)	121 (250)	139 (282)	157 (314)	174 (346)	192 (378)	On
75	113 500 (16 460)	103 (218)	122 (251)	139 (283)	157 (315)	175 (347)	193 (379)	Off
85	113 500 (16 460)	104 (220)	123 (253)	141 (285)	158 (317)	176 (349)	194 (381)	On
90	113 500 (16 460)	105 (221)	123 (254)	141 (286)	159 (318)	177 (350)	194 (382)	Off
100	113 500 (16 460)	106 (223)	124 (256)	142 (288)	160 (320)	178 (352)	196 (384)	On
105	113 500 (16 460)	107 (224)	125 (257)	143 (289)	161 (321)	178 (353)	196 (385)	Off
115	113 500 (16 460)	108 (226)	126 (259)	144 (291)	162 (323)	179 (355)	197 (387)	On
120	113 500 (16 460)	108 (227)	127 (260)	144 (292)	162 (324)	180 (356)	198 (388)	Off
130	113 500 (16 460)	109 (229)	128 (262)	146 (294)	163 (326)	181 (358)	199 (390)	On



Table E.4 (continued)

1	2	3	4	5	6	7	8	9
Time	Pressure	Temperature gradient, °C/100 m depth (°F/100 ft depth)						Stirring
		1,6 (0,9)	2,0 (1,1)	2,4 (1,3)	2,7 (1,5)	3,1 (1,7)	3,5 (1,9)	
min	kPa (psi)	Temperature						Stirring
		°C (°F)	°C (°F)	°C (°F)	°C (°F)	°C (°F)	°C (°F)	
		Depth: 5 490 m (18 000 ft)			Mud density: 1,87 kg/l (15,6 lbm/gal)			
135	113 500 (16 460)	110 (230)	128 (263)	146 (295)	164 (327)	182 (359)	199 (391)	Off
145	113 500 (16 460)	111 (232)	129 (265)	147 (297)	165 (329)	183 (361)	201 (393)	On
150	113 500 (16 460)	112 (233)	130 (266)	148 (298)	166 (330)	183 (362)	201 (394)	Off
160	113 500 (16 460)	113 (235)	131 (268)	149 (300)	167 (332)	184 (364)	202 (396)	On
165	113 500 (16 460)	113 (236)	132 (269)	149 (301)	167 (333)	185 (365)	203 (397)	Off
175	113 500 (16 460)	114 (238)	133 (271)	151 (303)	168 (335)	186 (367)	204 (399)	On
180	113 500 (16 460)	115 (239)	133 (272)	151 (304)	169 (336)	187 (368)	204 (400)	Off
190	113 500 (16 460)	116 (241)	134 (274)	152 (306)	170 (338)	188 (370)	206 (402)	On
195	113 500 (16 460)	117 (242)	135 (275)	153 (307)	171 (339)	188 (371)	206 (403)	Off
205	113 500 (16 460)	117 (242)	136 (277)	154 (309)	172 (341)	189 (373)	207 (405)	On
210	113 500 (16 460)	117 (242)	137 (278)	154 (310)	172 (342)	190 (374)	208 (406)	Off
220	113 500 (16 460)	117 (242)	137 (278)	156 (312)	173 (344)	191 (376)	209 (408)	On
225	113 500 (16 460)	117 (242)	137 (278)	156 (313)	174 (345)	192 (377)	209 (409)	Off
235	113 500 (16 460)	117 (242)	137 (278)	157 (314)	175 (347)	193 (379)	211 (411)	On
240	113 500 (16 460)	117 (242)	137 (278)	157 (314)	176 (348)	193 (380)	211 (412)	Off
250	113 500 (16 460)	117 (242)	137 (278)	157 (314)	177 (350)	194 (382)	212 (414)	On
255	113 500 (16 460)	117 (242)	137 (278)	157 (314)	177 (350)	195 (383)	213 (415)	Off
265	113 500 (16 460)	117 (242)	137 (278)	157 (314)	177 (350)	196 (385)	214 (417)	On
270	113 500 (16 460)	117 (242)	137 (278)	157 (314)	177 (350)	197 (386)	214 (418)	Off
280	113 500 (16 460)	117 (242)	137 (278)	157 (314)	177 (350)	197 (386)	216 (420)	On
285	113 500 (16 460)	117 (242)	137 (278)	157 (314)	177 (350)	197 (386)	216 (421)	Off
295	113 500 (16 460)	117 (242)	137 (278)	157 (314)	177 (350)	197 (386)	217 (422)	On
300	113 500 (16 460)	117 (242)	137 (278)	157 (314)	177 (350)	197 (386)	217 (422)	Off
<b>Segment 1</b>								
Ramp (deg/min)		1,71 (3,07)	2,12 (3,82)	2,53 (4,55)	2,93 (5,27)	3,33 (6,00)	3,74 (6,73)	
Ramp time		44 min						
Temp. dwell		16 min						
Pressure rate (per min)		1 895 kPa (275 psi) for 44 min, then 931 kPa (135 psi) for 16 min						
<b>Segment 2</b>								
Ramp (deg/min)		0,11 (0,20)	0,11 (0,20)	0,11 (0,20)	0,11 (0,20)	0,11 (0,20)	0,11 (0,20)	
Ramp time		135 min	150 min	170 min	190 min	210 min	235 min	



Table E.4 (continued)

1	2	3	4	5	6	7	8	9
Time min	Pressure kPa (psi)	Temperature gradient, °C/100 m depth (°F/100 ft depth)						Stirring
		1,6 (0,9)	2,0 (1,1)	2,4 (1,3)	2,7 (1,5)	3,1 (1,7)	3,5 (1,9)	
		Temperature						
		°C (°F)	°C (°F)	°C (°F)	°C (°F)	°C (°F)	°C (°F)	
Depth: 6 095 m (20 000 ft)				Mud density: 2,03 kg/l (16,9 lbm/gal)				
0	16 500 (2 400)	27 (80)	27 (80)	27 (80)	27 (80)	27 (80)	27 (80)	On
1	18 600 (2 695)	28 (83)	29 (84)	29 (85)	29 (85)	30 (86)	31 (87)	On
2	20 600 (2 990)	30 (86)	31 (88)	32 (89)	33 (91)	33 (92)	34 (94)	On
3	22 700 (3 285)	32 (89)	33 (92)	34 (94)	36 (96)	37 (98)	38 (101)	On
4	24 700 (3 580)	34 (93)	36 (96)	37 (99)	39 (102)	40 (104)	42 (108)	On
5	26 700 (3 875)	36 (96)	37 (99)	39 (103)	42 (107)	44 (111)	46 (114)	On
6	28 800 (4 170)	37 (99)	39 (103)	42 (108)	44 (112)	47 (117)	49 (121)	On
7	30 800 (4 465)	39 (102)	42 (107)	44 (112)	48 (118)	51 (123)	53 (128)	On
8	32 800 (4 760)	41 (105)	44 (111)	47 (117)	51 (123)	54 (129)	57 (135)	On
9	34 900 (5 055)	42 (108)	46 (115)	50 (122)	53 (128)	57 (135)	61 (142)	On
10	36 900 (5 350)	44 (111)	48 (119)	52 (126)	57 (134)	61 (141)	65 (149)	On
11	38 900 (5 645)	46 (115)	51 (123)	55 (131)	59 (139)	64 (147)	69 (156)	On
12	41 000 (5 940)	48 (118)	53 (127)	58 (136)	63 (145)	67 (153)	73 (163)	On
13	43 000 (6 235)	49 (121)	55 (131)	60 (140)	66 (150)	71 (160)	76 (169)	On
14	45 000 (6 530)	51 (124)	57 (135)	63 (145)	68 (155)	74 (166)	80 (176)	On
15	47 100 (6 825)	53 (127)	59 (138)	65 (149)	72 (161)	78 (172)	84 (183)	On
16	49 100 (7 120)	54 (130)	61 (142)	68 (154)	74 (166)	81 (178)	88 (190)	On
17	51 100 (7 415)	56 (133)	63 (146)	71 (159)	78 (172)	84 (184)	92 (197)	On
18	53 200 (7 710)	58 (137)	66 (150)	73 (163)	81 (177)	88 (190)	96 (204)	On
19	55 200 (8 005)	60 (140)	68 (154)	76 (168)	83 (182)	91 (196)	99 (211)	On
20	57 200 (8 300)	62 (143)	70 (158)	78 (173)	87 (188)	94 (202)	103 (218)	On
21	59 300 (8 595)	63 (146)	72 (162)	81 (177)	89 (193)	98 (209)	107 (224)	On
22	61 300 (8 890)	65 (149)	74 (166)	83 (182)	93 (199)	102 (215)	111 (231)	On
23	63 300 (9 185)	67 (152)	77 (170)	86 (187)	96 (204)	105 (221)	114 (238)	On
24	65 400 (9 480)	68 (155)	79 (174)	88 (191)	98 (209)	108 (227)	118 (245)	On
25	67 400 (9 775)	71 (159)	81 (177)	91 (196)	102 (215)	112 (233)	122 (252)	On
26	69 400 (10 070)	72 (162)	83 (181)	93 (200)	104 (220)	115 (239)	126 (259)	On
27	71 500 (10 365)	74 (165)	85 (185)	96 (205)	107 (225)	118 (245)	130 (266)	On
28	73 500 (10 660)	76 (168)	87 (189)	99 (210)	111 (231)	122 (251)	134 (273)	On
29	75 500 (10 955)	77 (171)	89 (193)	101 (214)	113 (236)	126 (258)	137 (279)	On
30	77 600 (11 250)	79 (174)	92 (197)	104 (219)	117 (242)	129 (264)	141 (286)	On
31	79 600 (11 545)	81 (177)	94 (201)	107 (224)	119 (247)	132 (270)	145 (293)	On
32	81 600 (11 840)	83 (181)	96 (205)	109 (228)	122 (252)	136 (276)	149 (300)	On
33	83 700 (12 135)	84 (184)	98 (209)	112 (233)	126 (258)	139 (282)	153 (307)	On
34	85 700 (12 430)	86 (187)	101 (213)	114 (238)	128 (263)	142 (288)	157 (314)	On

Table E.4 (continued)

1	2	3	4	5	6	7	8	9	
Time	Pressure	Temperature gradient, °C/100 m depth (°F/100 ft depth)						Stirring	
		1,6 (0,9)	2,0 (1,1)	2,4 (1,3)	2,7 (1,5)	3,1 (1,7)	3,5 (1,9)		
		Temperature							
min	kPa (psi)	°C (°F)	°C (°F)	°C (°F)	°C (°F)	°C (°F)	°C (°F)		
Depth: 6 095 m (20 000 ft)			Mud density: 2,03 kg/l (16,9 lbm/gal)						
35	87 700 (12 725)	88 (190)	102 (216)	117 (242)	132 (269)	146 (294)	161 (321)	On	
36	89 800 (13 020)	89 (193)	104 (220)	119 (247)	134 (274)	149 (300)	164 (328)	On	
37	91 800 (13 315)	91 (196)	107 (224)	122 (251)	137 (279)	153 (307)	168 (334)	On	
38	93 800 (13 610)	93 (199)	109 (228)	124 (256)	141 (285)	156 (313)	172 (341)	On	
39	95 900 (13 905)	95 (203)	111 (232)	127 (261)	143 (290)	159 (319)	176 (348)	On	
40	97 900 (14 200)	97 (206)	113 (236)	129 (265)	147 (296)	163 (325)	179 (355)	On	
41	99 900 (14 495)	98 (209)	116 (240)	132 (270)	149 (301)	166 (331)	183 (362)	On	
42	102 000 (14 790)	100 (212)	118 (244)	135 (275)	152 (306)	169 (337)	187 (369)	On	
43	104 000 (15 085)	102 (215)	120 (248)	137 (279)	156 (312)	173 (343)	191 (376)	On	
44	106 000 (15 380)	103 (218)	122 (252)	140 (284)	158 (317)	176 (349)	195 (383)	On	
45	108 100 (15 675)	105 (221)	124 (255)	142 (288)	161 (322)	180 (356)	198 (389)	On	
46	110 100 (15 970)	107 (225)	126 (259)	145 (293)	164 (328)	183 (362)	202 (396)	On	
47	112 100 (16 265)	109 (228)	128 (263)	148 (298)	167 (333)	187 (368)	206 (403)	On	
48	114 200 (16 560)	111 (231)	131 (267)	150 (302)	171 (339)	190 (374)	210 (410)	On	
49	116 200 (16 855)	112 (234)	133 (271)	153 (307)	173 (344)	193 (380)	214 (417)	On	
50	117 400 (17 030)	112 (234)	133 (271)	153 (307)	173 (344)	193 (380)	214 (417)	On	
51	118 600 (17 205)	112 (234)	133 (271)	153 (307)	173 (344)	193 (380)	214 (417)	On	
52	119 800 (17 380)	112 (234)	133 (271)	153 (307)	173 (344)	193 (380)	214 (417)	On	
53	121 000 (17 555)	112 (234)	133 (271)	153 (307)	173 (344)	193 (380)	214 (417)	On	
54	122 200 (17 730)	112 (234)	133 (271)	153 (307)	173 (344)	193 (380)	214 (417)	On	
55	123 500 (17 905)	112 (234)	133 (271)	153 (307)	173 (344)	193 (380)	214 (417)	On	
56	124 700 (18 080)	112 (234)	133 (271)	153 (307)	173 (344)	193 (380)	214 (417)	On	
57	125 900 (18 255)	112 (234)	133 (271)	153 (307)	173 (344)	193 (380)	214 (417)	On	
58	127 100 (18 430)	112 (234)	133 (271)	153 (307)	173 (344)	193 (380)	214 (417)	On	
59	128 300 (18 605)	112 (234)	133 (271)	153 (307)	173 (344)	193 (380)	214 (417)	On	
60	129 500 (18 780)	112 (234)	133 (271)	153 (307)	173 (344)	193 (380)	214 (417)	Off	
70	129 500 (18 780)	113 (236)	134 (273)	154 (309)	174 (346)	194 (382)	215 (419)	On	
75	129 500 (18 780)	114 (237)	134 (274)	154 (310)	175 (347)	195 (383)	216 (420)	Off	
85	129 500 (18 780)	115 (239)	136 (276)	156 (312)	176 (349)	196 (385)	217 (422)	On	
90	129 500 (18 780)	116 (240)	136 (277)	156 (313)	177 (350)	197 (386)	217 (423)	Off	
100	129 500 (18 780)	117 (242)	137 (279)	157 (315)	178 (352)	198 (388)	218 (425)	On	
105	129 500 (18 780)	117 (243)	138 (280)	158 (316)	178 (353)	198 (389)	219 (426)	Off	
115	129 500 (18 780)	118 (245)	139 (282)	159 (318)	179 (354)	199 (391)	220 (428)	On	
120	129 500 (18 780)	119 (246)	139 (283)	159 (319)	180 (356)	200 (392)	221 (429)	Off	
130	129 500 (18 780)	120 (248)	141 (285)	161 (321)	181 (357)	201 (394)	222 (431)	On	

Table E.4 (continued)

1	2	3	4	5	6	7	8	9
Time min	Pressure kPa (psi)	Temperature gradient, °C/100 m depth (°F/100 ft depth)						Stirring
		1,6 (0,9)	2,0 (1,1)	2,4 (1,3)	2,7 (1,5)	3,1 (1,7)	3,5 (1,9)	
		Temperature						
		°C (°F)	°C (°F)	°C (°F)	°C (°F)	°C (°F)	°C (°F)	
		Depth: 6 095 m (20 000 ft)			Mud density: 2,03 kg/l (16,9 lbm/gal)			
135	129 500 (18 780)	121 (249)	141 (286)	161 (322)	182 (359)	202 (395)	222 (432)	Off
145	129 500 (18 780)	122 (251)	142 (288)	162 (324)	183 (360)	203 (397)	223 (434)	On
150	129 500 (18 780)	122 (252)	143 (289)	163 (325)	183 (362)	203 (398)	224 (435)	Off
160	129 500 (18 780)	123 (254)	144 (291)	164 (327)	184 (364)	204 (400)	225 (437)	On
165	129 500 (18 780)	124 (255)	144 (292)	164 (328)	185 (365)	205 (401)	226 (438)	Off
175	129 500 (18 780)	125 (257)	146 (294)	166 (330)	186 (367)	206 (403)	227 (440)	On
180	129 500 (18 780)	126 (258)	146 (295)	166 (331)	187 (368)	207 (404)	227 (441)	Off
190	129 500 (18 780)	127 (260)	147 (297)	167 (333)	188 (370)	208 (406)	228 (443)	On
195	129 500 (18 780)	127 (260)	148 (298)	168 (334)	188 (371)	208 (407)	229 (444)	Off
205	129 500 (18 780)	127 (260)	149 (300)	169 (336)	189 (373)	209 (409)	230 (446)	On
210	129 500 (18 780)	127 (260)	149 (300)	169 (337)	190 (374)	210 (410)	231 (447)	Off
220	129 500 (18 780)	127 (260)	149 (300)	171 (339)	191 (376)	211 (412)	232 (449)	On
225	129 500 (18 780)	127 (260)	149 (300)	171 (340)	192 (377)	212 (413)	232 (450)	Off
235	129 500 (18 780)	127 (260)	149 (300)	171 (340)	193 (379)	213 (415)	233 (452)	On
240	129 500 (18 780)	127 (260)	149 (300)	171 (340)	193 (380)	213 (416)	234 (453)	Off
250	129 500 (18 780)	127 (260)	149 (300)	171 (340)	193 (380)	214 (418)	235 (455)	On
255	129 500 (18 780)	127 (260)	149 (300)	171 (340)	193 (380)	215 (419)	236 (456)	Off
265	129 500 (18 780)	127 (260)	149 (300)	171 (340)	193 (380)	216 (420)	237 (458)	On
270	129 500 (18 780)	127 (260)	149 (300)	171 (340)	193 (380)	216 (420)	237 (459)	Off
280	129 500 (18 780)	127 (260)	149 (300)	171 (340)	193 (380)	216 (420)	238 (460)	On
285	129 500 (18 780)	127 (260)	149 (300)	171 (340)	193 (380)	216 (420)	238 (460)	Off
295	129 500 (18 780)	127 (260)	149 (300)	171 (340)	193 (380)	216 (420)	238 (460)	On
300	129 500 (18 780)	127 (260)	149 (300)	171 (340)	193 (380)	216 (420)	238 (460)	Off
<b>Segment 1</b>								
Ramp (deg/min)		1,74 (3,14)	2,17 (3,90)	2,57 (4,63)	2,99 (5,39)	3,40 (6,12)	3,82 (6,88)	
Ramp time		49 min						
Temp. dwell		11 min						
Pressure rate (per min)		2 035 kPa (295 psi) for 49 min, then 1 209 kPa (175 psi) for 11 min						
<b>Segment 2</b>								
Ramp (deg/min)		0,11 (0,20)	0,11 (0,20)	0,11 (0,20)	0,11 (0,20)	0,11 (0,20)	0,11 (0,20)	
Ramp time		130 min	145 min	165 min	180 min	200 min	215 min	

Table E.4 — (continued)

1	2	3	4	5	6	7	8	9		
Time min	Pressure kPa (psi)	Temperature gradient, °C/100 m depth (°F/100 ft depth)								Stirring
		1,6 (0,9)	2,0 (1,1)	2,4 (1,3)	2,7 (1,5)	3,1 (1,7)	3,5 (1,9)	Temperature		
		°C (°F)	°C (°F)	°C (°F)	°C (°F)	°C (°F)	°C (°F)	°C (°F)	°C (°F)	
Depth: 6 705 m (22 000 ft)				Mud density: 2,18 kg/l (18,2 lbm/gal)						
0	17 900 (2 600)	27 (80)	27 (80)	27 (80)	27 (80)	27 (80)	27 (80)	27 (80)	On	
1	20 100 (2 910)	28 (83)	29 (84)	29 (85)	30 (86)	30 (86)	30 (86)	31 (87)	On	
2	22 200 (3 220)	30 (86)	31 (88)	32 (89)	33 (91)	34 (93)	34 (93)	34 (94)	On	
3	24 300 (3 530)	32 (90)	33 (92)	34 (94)	36 (97)	37 (99)	37 (99)	38 (101)	On	
4	26 500 (3 840)	34 (93)	36 (96)	37 (99)	39 (102)	41 (105)	41 (105)	42 (108)	On	
5	28 600 (4 150)	36 (96)	38 (100)	40 (104)	42 (108)	44 (111)	44 (111)	46 (115)	On	
6	30 800 (4 460)	37 (99)	40 (104)	42 (108)	45 (113)	48 (118)	48 (118)	50 (122)	On	
7	32 900 (4 770)	39 (103)	42 (108)	45 (113)	48 (119)	51 (124)	51 (124)	54 (129)	On	
8	35 000 (5 080)	41 (106)	44 (112)	48 (118)	51 (124)	54 (130)	54 (130)	58 (136)	On	
9	37 200 (5 390)	43 (109)	47 (116)	51 (123)	54 (130)	58 (136)	58 (136)	62 (143)	On	
10	39 300 (5 700)	44 (112)	49 (120)	53 (127)	57 (135)	62 (143)	62 (143)	66 (150)	On	
11	41 400 (6 010)	46 (115)	51 (124)	56 (132)	61 (141)	65 (149)	65 (149)	69 (157)	On	
12	43 600 (6 320)	48 (119)	53 (128)	58 (137)	63 (146)	68 (155)	68 (155)	73 (164)	On	
13	45 700 (6 630)	50 (122)	56 (132)	61 (142)	67 (152)	72 (161)	72 (161)	77 (171)	On	
14	47 900 (6 940)	52 (125)	58 (136)	63 (146)	69 (157)	76 (168)	76 (168)	81 (178)	On	
15	50 000 (7 250)	53 (128)	60 (140)	66 (151)	73 (163)	79 (174)	79 (174)	85 (185)	On	
16	52 100 (7 560)	56 (132)	62 (144)	69 (156)	76 (168)	82 (180)	82 (180)	89 (192)	On	
17	54 300 (7 870)	57 (135)	64 (148)	72 (161)	79 (174)	86 (186)	86 (186)	93 (199)	On	
18	56 400 (8 180)	59 (138)	67 (152)	74 (165)	82 (179)	89 (193)	89 (193)	97 (206)	On	
19	58 500 (8 490)	61 (141)	69 (156)	77 (170)	85 (185)	93 (199)	93 (199)	101 (213)	On	
20	60 700 (8 800)	62 (144)	71 (160)	79 (175)	88 (190)	96 (205)	96 (205)	104 (220)	On	
21	62 800 (9 110)	64 (148)	73 (164)	82 (180)	91 (196)	99 (211)	99 (211)	108 (227)	On	
22	65 000 (9 420)	66 (151)	76 (168)	84 (184)	94 (201)	103 (218)	103 (218)	112 (234)	On	
23	67 100 (9 730)	68 (154)	78 (172)	87 (189)	97 (207)	107 (224)	107 (224)	116 (241)	On	
24	69 200 (10 040)	69 (157)	80 (176)	90 (194)	100 (212)	110 (230)	110 (230)	120 (248)	On	
25	71 400 (10 350)	72 (161)	82 (180)	93 (199)	103 (218)	113 (236)	113 (236)	124 (255)	On	
26	73 500 (10 660)	73 (164)	84 (184)	95 (203)	106 (223)	117 (243)	117 (243)	128 (262)	On	
27	75 600 (10 970)	75 (167)	87 (188)	98 (208)	109 (229)	121 (249)	121 (249)	132 (270)	On	
28	77 800 (11 280)	77 (170)	88 (191)	101 (213)	112 (234)	124 (255)	124 (255)	136 (277)	On	
29	79 900 (11 590)	78 (173)	91 (195)	103 (217)	116 (240)	128 (262)	128 (262)	140 (284)	On	
30	82 100 (11 900)	81 (177)	93 (199)	106 (222)	118 (245)	131 (268)	131 (268)	144 (291)	On	
31	84 200 (12 210)	82 (180)	95 (203)	108 (227)	122 (251)	134 (274)	134 (274)	148 (298)	On	
32	86 300 (12 520)	84 (183)	97 (207)	111 (232)	124 (256)	138 (280)	138 (280)	152 (305)	On	
33	88 500 (12 830)	86 (186)	99 (211)	113 (236)	128 (262)	142 (287)	142 (287)	156 (312)	On	
34	90 600 (13 140)	88 (190)	102 (215)	116 (241)	131 (267)	145 (293)	145 (293)	159 (319)	On	

Table E.4 (continued)

1	2	3	4	5	6	7	8	9
Time min	Pressure kPa (psi)	Temperature gradient, °C/100 m depth (°F/100 ft depth)						Stirring
		1,6 (0,9)	2,0 (1,1)	2,4 (1,3)	2,7 (1,5)	3,1 (1,7)	3,5 (1,9)	
		Temperature						
		°C (°F)	°C (°F)	°C (°F)	°C (°F)	°C (°F)	°C (°F)	
Depth: 6 705 m (22 000 ft)						Mud density: 2,18 kg/l (18,2 lbm/gal)		
35	92 700 (13 450)	89 (193)	104 (219)	119 (246)	134 (273)	148 (299)	163 (326)	On
36	94 900 (13 760)	91 (196)	106 (223)	122 (251)	137 (278)	152 (305)	167 (333)	On
37	97 000 (14 070)	93 (199)	108 (227)	124 (255)	140 (284)	156 (312)	171 (340)	On
38	99 200 (14 380)	94 (202)	111 (231)	127 (260)	143 (289)	159 (318)	175 (347)	On
39	101 300 (14 690)	97 (206)	113 (235)	129 (265)	146 (295)	162 (324)	179 (354)	On
40	103 400 (15 000)	98 (209)	115 (239)	132 (270)	149 (300)	166 (330)	183 (361)	On
41	105 600 (15 310)	100 (212)	117 (243)	134 (274)	152 (306)	169 (337)	187 (368)	On
42	107 700 (15 620)	102 (215)	119 (247)	137 (279)	155 (311)	173 (343)	191 (375)	On
43	109 800 (15 930)	104 (219)	122 (251)	140 (284)	158 (317)	176 (349)	194 (382)	On
44	112 000 (16 240)	106 (222)	124 (255)	143 (289)	161 (322)	179 (355)	198 (389)	On
45	114 100 (16 550)	107 (225)	126 (259)	145 (293)	164 (328)	183 (362)	202 (396)	On
46	116 200 (16 860)	109 (228)	128 (263)	148 (298)	167 (333)	187 (368)	206 (403)	On
47	118 400 (17 170)	111 (231)	131 (267)	151 (303)	171 (339)	190 (374)	210 (410)	On
48	120 500 (17 480)	113 (235)	133 (271)	153 (308)	173 (344)	193 (380)	214 (417)	On
49	122 700 (17 790)	114 (238)	135 (275)	156 (312)	177 (350)	197 (387)	218 (424)	On
50	124 800 (18 100)	116 (241)	137 (279)	158 (317)	179 (355)	201 (393)	222 (431)	On
51	126 900 (18 410)	118 (244)	139 (283)	161 (322)	183 (361)	204 (399)	226 (438)	On
52	129 100 (18 720)	120 (248)	142 (287)	164 (327)	186 (366)	207 (405)	229 (445)	On
53	131 200 (19 030)	122 (251)	144 (291)	166 (331)	189 (372)	211 (412)	233 (452)	On
54	133 300 (19 340)	123 (254)	146 (295)	169 (336)	192 (377)	214 (418)	237 (459)	On
55	134 600 (19 515)	123 (254)	146 (295)	169 (336)	192 (377)	214 (418)	237 (459)	On
56	135 800 (19 690)	123 (254)	146 (295)	169 (336)	192 (377)	214 (418)	237 (459)	On
57	137 000 (19 865)	123 (254)	146 (295)	169 (336)	192 (377)	214 (418)	237 (459)	On
58	138 200 (20 040)	123 (254)	146 (295)	169 (336)	192 (377)	214 (418)	237 (459)	On
59	139 400 (20 215)	123 (254)	146 (295)	169 (336)	192 (377)	214 (418)	237 (459)	On
60	140 600 (20 390)	123 (254)	146 (295)	169 (336)	192 (377)	214 (418)	237 (459)	On
61	141 800 (20 565)	123 (254)	146 (295)	169 (336)	192 (377)	214 (418)	237 (459)	On
62	143 000 (20 740)	123 (254)	146 (295)	169 (336)	192 (377)	214 (418)	237 (459)	On
63	144 200 (20 915)	123 (254)	146 (295)	169 (336)	192 (377)	214 (418)	237 (459)	On
64	145 400 (21 090)	123 (254)	146 (295)	169 (336)	192 (377)	214 (418)	237 (459)	On
65	146 600 (21 265)	123 (254)	146 (295)	169 (336)	192 (377)	214 (418)	237 (459)	Off
75	146 600 (21 265)	124 (256)	147 (297)	170 (338)	193 (379)	216 (420)	238 (461)	On
80	146 600 (21 265)	125 (257)	148 (298)	171 (339)	193 (380)	216 (421)	239 (462)	Off
90	146 600 (21 265)	126 (259)	149 (300)	172 (341)	194 (382)	217 (423)	240 (464)	On
95	146 600 (21 265)	127 (260)	149 (301)	172 (342)	195 (383)	218 (424)	241 (465)	Off

Table E.4 (continued)

1	2	3	4	5	6	7	8	9
Time min	Pressure kPa (psi)	Temperature gradient, °C/100 m depth (°F/100 ft depth)						Stirring
		1,6 (0,9)	2,0 (1,1)	2,4 (1,3)	2,7 (1,5)	3,1 (1,7)	3,5 (1,9)	
		Temperature						
		°C (°F)	°C (°F)	°C (°F)	°C (°F)	°C (°F)	°C (°F)	
		Depth: 6 705 m (22 000 ft)			Mud density: 2,18 kg/l (18,2 lbm/gal)			
105	146 600 (21 265)	128 (262)	151 (303)	173 (344)	196 (385)	219 (426)	242 (467)	On
110	146 600 (21 265)	128 (263)	151 (304)	174 (345)	197 (386)	219 (427)	242 (468)	Off
120	146 600 (21 265)	129 (265)	152 (306)	175 (347)	198 (388)	221 (429)	243 (470)	On
125	146 600 (21 265)	130 (266)	153 (307)	176 (348)	198 (389)	221 (430)	244 (471)	Off
135	146 600 (21 265)	131 (268)	154 (309)	177 (350)	199 (391)	222 (432)	245 (473)	On
140	146 600 (21 265)	132 (269)	154 (310)	177 (351)	200 (392)	223 (433)	246 (474)	Off
150	146 600 (21 265)	133 (271)	156 (312)	178 (353)	201 (394)	224 (435)	247 (476)	On
155	146 600 (21 265)	133 (272)	156 (313)	179 (354)	202 (395)	224 (436)	247 (477)	Off
165	146 600 (21 265)	134 (274)	157 (315)	180 (356)	203 (397)	226 (438)	248 (479)	On
170	146 600 (21 265)	135 (275)	158 (316)	181 (357)	203 (398)	226 (439)	249 (480)	Off
180	146 600 (21 265)	136 (277)	159 (318)	182 (359)	204 (400)	227 (441)	250 (482)	On
185	146 600 (21 265)	137 (278)	159 (319)	182 (360)	205 (401)	228 (442)	251 (483)	Off
195	146 600 (21 265)	137 (278)	161 (321)	183 (362)	206 (403)	229 (444)	252 (485)	On
200	146 600 (21 265)	137 (278)	161 (322)	184 (363)	207 (404)	229 (445)	252 (486)	Off
210	146 600 (21 265)	137 (278)	161 (322)	185 (365)	208 (406)	231 (447)	253 (488)	On
215	146 600 (21 265)	137 (278)	161 (322)	186 (366)	208 (407)	231 (448)	254 (489)	Off
225	146 600 (21 265)	137 (278)	161 (322)	186 (366)	209 (409)	232 (450)	255 (491)	On
230	146 600 (21 265)	137 (278)	161 (322)	186 (366)	210 (410)	233 (451)	256 (492)	Off
240	146 600 (21 265)	137 (278)	161 (322)	186 (366)	210 (410)	234 (453)	257 (494)	On
245	146 600 (21 265)	137 (278)	161 (322)	186 (366)	210 (410)	234 (454)	257 (495)	Off
255	146 600 (21 265)	137 (278)	161 (322)	186 (366)	210 (410)	234 (454)	258 (497)	On
260	146 600 (21 265)	137 (278)	161 (322)	186 (366)	210 (410)	234 (454)	259 (498)	Off
270	146 600 (21 265)	137 (278)	161 (322)	186 (366)	210 (410)	234 (454)	259 (498)	On
275	146 600 (21 265)	137 (278)	161 (322)	186 (366)	210 (410)	234 (454)	259 (498)	Off
<b>Segment 1</b>								
Ramp (deg/min)		1,79 (3,22)	2,21 (3,98)	2,63 (4,74)	3,06 (5,50)	3,48 (6,26)	3,90 (7,02)	
Ramp time		54 min						
Temp. dwell		11 min						
Pressure rate (per min)		2 137 kPa (310 psi) for 54 min, then 1 209 kPa (175 psi) for 11 min						
<b>Segment 2</b>								
Ramp (deg/min)		0,11 (0,20)	0,11 (0,20)	0,11 (0,20)	0,11 (0,20)	0,11 (0,20)	0,11 (0,20)	
Ramp time		120 min	135 min	150 min	165 min	180 min	195 min	

## Bibliography

- [1] API RP10B, *Recommended practice for testing well cements*, 22nd edition, December 1997
- [2] API Spec 10, *Specification for materials and testing for well cements*, 5th edition, July 1990
- [3] ASTM C 183, *Standard practice for sampling and the amount of testing of hydraulic cement*
- [4] ASTM C 618, *Standard specification for coal fly ash and raw or calcined natural pozzolan for use in concrete*
- [5] ASTM E 220, *Standard test method for calibration of thermocouples by comparison techniques*
- [6] API Report 10TR3, *Technical report on temperatures for API cement operating thickening time tests*, 1st edn., May 1999





**National annex NA (informative)****Additional information on the testing of well cements****NA.1 Operating free-fluid tests**

The operating free-fluid tests given in Clause **15**, namely the free-fluid test with heated static period (**15.4**) and the free-fluid test with ambient temperature static period (**15.5**) are variants of the original free-fluid test (measuring cylinder method) given in API Specification 10A. They differ from the free-fluid test specified in BS EN ISO 10426-1:2000, Clause **8**, which involves a conical flask for the actual measurement of free fluid.

No limits on percentage free fluid are quoted for the operating free-fluid tests, since the value required depends on how critical the actual well cement slurry is for each specific downhole cementing job. For cementing critical well sections, zero free fluid is normally required. For non-critical well sections the maximum limit is higher, but is unlikely to exceed 3,5 ml (1,4 %) for most well cementing jobs. In some instances a lower limit is set, depending upon the well conditions.

**NA.2 Schedules for laboratory testing of well cements**

The cementing Schedules given in Annex E (informative) are considered to be an improvement on the previous Schedules given in the now obsolete publication API Specification 10. On a global basis there are different geothermal pressure/temperature gradients in different areas. Consequently, depths quoted should be regarded as approximate and not as a necessarily correct value of depth in a given location.

A number of past and present Schedules, originally developed by the API for use at different well depths, are still periodically employed in some individual laboratory quality control tests for well cements and/or additives for use with well cements. Examples of idealized mud densities pertaining to the original well depths designed are given for information in Table NA.1.

**Table NA.1 — Description of Schedules 1 to 11**

Schedule no.	Original depth designed for <sup>a</sup>		Mud density <sup>a</sup>	
	metres	(feet)	kg/L	(lb/US gal)
1	305	(1 000)	1,2	(10)
2	610	(2 000)	1,2	(10)
3	1 220	(4 000)	1,2	(10)
4	1 830	(6 000)	1,2	(10)
5	2 440	(8 000)	1,2	(10)
6	3 050	(10 000)	1,4	(12)
7	3 660	(12 000)	1,7	(14)
8	4 270	(14 000)	1,9	(16)
9	4 880	(16 000)	2,0	(17)
10	5 490	(18 000)	2,2	(18)
11	6 100	(20 000)	2,3	(19)

<sup>a</sup> Note the commentary given in NA.2 concerning well depths, mud densities, different geothermal temperatures and pressure gradients.

Schedules 4, 5, 6, 8 and 9 have now become ISO Schedules. They are used for the specification testing of different classes of well cements, and are described in BS EN ISO 10426-1. The former API Schedules 1, 2, 3, 7, 10 and 11 together with the ISO Schedules 4, 5, 6, 8 and 9 have been periodically used in some laboratories for additional non-mandatory testing, such as thickening time under specified pressure/temperature conditions. This is done to check the performance of well cements under a variety of conditions with or without different additives. For instance, Schedules 1 to 4 are used for shallow well testing, Schedules 5 to 8 for medium depth well testing and Schedules 9 to 11 for deep well testing.

The API casing cementing Schedules 1, 2, 3, 7, 10 and 11 were given in API RP 10B, but were later withdrawn as they were not mandatory specification requirements. However, they are still used in the optional in-house quality control testing of well cements. These former casing Schedules are set out here for information in Table NA.2, Table NA.3, Table NA.4, Table NA.5, Table NA.6 and Table NA.7, giving both the SI units and the original US customary units in parenthesis. Temperature and pressure is maintained within  $\pm 1$  °C ( $\pm 2$  °F) and  $\pm 0,7$  MPa ( $\pm 100$  psi) of the given Schedule throughout the test.

Table NA.2 — Schedule 1 test

Elapsed time min	Pressure		Temperature	
	MPa	(psi)	°C	(°F)
0	3,4	(500)	27	(80)
2	4,1	(600)	27	(80)
4	5,5	(800)	27	(80)
6	6,2	(900)	27	(80)
7	7,0	(1 000)	27	(80)

Table NA.3 — Schedule 2 test

Elapsed time min	Pressure		Temperature	
	MPa	(psi)	°C	(°F)
0	3,4	(500)	27	(80)
2	4,8	(700)	28	(82)
4	6,9	(1 000)	29	(85)
6	8,2	(1 200)	31	(87)
8	9,7	(1 400)	32	(90)
9	10,6	(1 540)	33	(91)

Table NA.4 — Schedule 3 test

Elapsed time min	Pressure		Temperature	
	MPa	(psi)	°C	(°F)
0	3,4	(500)	27	(80)
2	5,5	(800)	28	(83)
4	7,6	(1 100)	31	(87)
6	9,7	(1 400)	32	(90)
8	11,6	(1 700)	34	(93)
10	13,8	(2 000)	36	(96)
12	15,9	(2 300)	38	(100)
14	17,6	(2 580)	39	(103)

Table NA.5 — Schedule 7 test

Elapsed time min	Pressure		Temperature	
	MPa	(psi)	°C	(°F)
0	10,3	(1 500)	27	(80)
2	13,1	(1 900)	29	(84)
4	16,6	(2 300)	31	(88)
6	18,6	(2 700)	34	(93)
8	21,4	(3 100)	36	(97)
10	24,1	(3 500)	38	(101)
12	26,9	(3 900)	41	(105)
14	29,6	(4 300)	43	(109)
16	32,4	(4 700)	45	(113)
18	35,2	(5 100)	48	(118)
20	37,9	(5 500)	50	(122)
22	40,7	(5 900)	52	(126)
24	43,4	(6 300)	54	(130)
26	46,2	(6 700)	57	(134)
28	49,0	(7 100)	59	(139)
30	51,7	(7 500)	62	(143)
32	53,8	(7 800)	64	(147)
34	56,5	(8 200)	66	(151)
36	59,3	(8 600)	68	(155)
38	62,1	(9 000)	71	(159)
40	64,9	(9 400)	73	(164)
42	67,6	(9 800)	76	(168)
44	70,5	(10 230)	78	(172)

Table NA.6 — Schedule 10 test

Elapsed time min	Pressure		Temperature	
	MPa	(psi)	°C	(°F)
0	13,8	(2 000)	27	(80)
2	17,2	(2 500)	31	(87)
4	20,7	(3 000)	34	(93)
6	24,1	(3 500)	38	(100)
8	27,6	(4 000)	41	(106)
10	31,0	(4 500)	45	(113)
12	34,5	(5 000)	48	(119)
14	38,0	(5 500)	52	(126)
16	41,4	(6 000)	56	(133)
18	44,8	(6 500)	59	(139)
20	48,3	(7 000)	63	(146)
22	51,7	(7 500)	67	(152)
24	55,2	(8 000)	71	(159)
26	58,6	(8 500)	74	(165)
28	62,1	(9 000)	78	(172)
30	65,5	(9 500)	82	(179)
32	68,9	(10 000)	85	(185)
34	72,4	(10 500)	89	(192)
36	75,8	(11 000)	92	(198)
38	79,3	(11 500)	96	(205)
40	82,7	(12 000)	99	(211)
42	86,2	(12 500)	103	(218)
44	89,6	(13 000)	107	(224)
46	93,1	(13 500)	111	(231)
48	96,5	(14 000)	114	(238)
50	100,0	(14 500)	118	(244)
52	103,4	(15 000)	122	(251)
54	106,9	(15 500)	125	(257)
56	110,3	(16 000)	129	(264)
58	113,8	(16 500)	132	(270)
60	117,3	(17 000)	136	(277)
62	120,7	(17 500)	140	(284)
64	124,1	(18 000)	143	(290)
66	127,6	(18 500)	147	(297)
67	129,6	(18 800)	149	(300)

Table NA.7 — Schedule 11 test

Elapsed time min	Pressure		Temperature	
	MPa	(psi)	°C	(°F)
0	15,5	(2 250)	27	(80)
2	19,3	(2 800)	31	(87)
4	22,8	(3 300)	34	(94)
6	26,2	(3 800)	38	(101)
8	30,3	(4 400)	42	(108)
10	33,8	(4 900)	46	(115)
12	37,2	(5 400)	50	(122)
14	40,7	(5 900)	54	(129)
16	44,8	(6 500)	57	(135)
18	48,3	(7 000)	61	(142)
20	51,7	(7 500)	65	(149)
22	55,2	(8 000)	69	(156)
24	59,3	(8 600)	73	(163)
26	62,7	(9 100)	77	(170)
28	66,2	(9 600)	81	(177)
30	69,6	(10 100)	84	(184)
32	73,8	(10 700)	88	(191)
34	77,2	(11 200)	92	(198)
36	80,7	(11 700)	96	(205)
38	84,1	(12 200)	100	(212)
40	88,3	(12 800)	104	(219)
42	91,7	(13 300)	108	(226)
44	95,1	(13 800)	112	(233)
46	98,6	(14 300)	115	(239)
48	102,7	(14 900)	119	(246)
50	106,2	(15 400)	123	(253)
52	109,6	(15 900)	127	(260)
54	113,1	(16 400)	131	(267)
56	117,2	(17 000)	134	(274)
58	120,7	(17 500)	138	(281)
60	124,1	(18 000)	142	(288)
62	128,2	(18 600)	146	(295)
64	131,7	(19 100)	150	(302)
66	135,1	(19 600)	154	(309)
68	138,6	(20 100)	158	(316)
70	142,7	(20 700)	162	(323)
72	146,2	(21 200)	166	(330)
74	149,6	(21 700)	169	(337)
75	151,5	(21 970)	171	(340)

### **NA.3 Free lime**

Free lime (CaO) in cements is measured either by the ethylene glycol method or by X-ray diffraction.

Simple mandatory limits for free lime are not ascribed on a worldwide basis, because of the many interactive effects from other cement constituents which influence overall cementitious reactivity. High levels of free lime can affect:

- a) additive (especially retarder) responses;
- b) rheological characteristics of well cement slurries (like plastic viscosity and yield point);
- c) fluid loss results (high).

Optimization of free lime levels is achieved on a plant-by-plant basis. In most circumstances a useful “rule of thumb” guide for free lime limits applies as follows:

- a) if the magnesium oxide (MgO) content of the cement is 1,5 % mass or less, free lime is limited to 1,0 % mass or below;
- b) if the MgO content lies above 1,5 % mass, the free lime is limited to 0,5 % mass or below.

There are some individual exceptions to this “rule of thumb”, for example where higher free lime levels give adequate retardation with appropriate retarder concentrations.

**National bibliography**

API Specification 10, *Specification for Materials and Testing for Well Cements*. 5th Edition. Washington DC: American Petroleum Institute, 1990.

API Specification 10A, *Well Cements*. 22nd Edition. Washington DC: American Petroleum Institute, 1995.

API RP 10B, *Recommended Practice for Testing Oilwell Cements and Cement Additives*. 12th Edition. Washington DC: American Petroleum Institute, 1963.

BS EN ISO 10426-1:2000 including Amendment 1:2002, *Petroleum and natural gas industries — Cements and materials for well cementing — Part 1: Specification*.





---

---

## BSI — British Standards Institution

BSI is the independent national body responsible for preparing British Standards. It presents the UK view on standards in Europe and at the international level. It is incorporated by Royal Charter.

### Revisions

British Standards are updated by amendment or revision. Users of British Standards should make sure that they possess the latest amendments or editions.

It is the constant aim of BSI to improve the quality of our products and services. We would be grateful if anyone finding an inaccuracy or ambiguity while using this British Standard would inform the Secretary of the technical committee responsible, the identity of which can be found on the inside front cover. Tel: +44 (0)20 8996 9000. Fax: +44 (0)20 8996 7400.

BSI offers members an individual updating service called PLUS which ensures that subscribers automatically receive the latest editions of standards.

### Buying standards

Orders for all BSI, international and foreign standards publications should be addressed to Customer Services. Tel: +44 (0)20 8996 9001. Fax: +44 (0)20 8996 7001. Email: [orders@bsi-global.com](mailto:orders@bsi-global.com). Standards are also available from the BSI website at <http://www.bsi-global.com>.

In response to orders for international standards, it is BSI policy to supply the BSI implementation of those that have been published as British Standards, unless otherwise requested.

### Information on standards

BSI provides a wide range of information on national, European and international standards through its Library and its Technical Help to Exporters Service. Various BSI electronic information services are also available which give details on all its products and services. Contact the Information Centre. Tel: +44 (0)20 8996 7111. Fax: +44 (0)20 8996 7048. Email: [info@bsi-global.com](mailto:info@bsi-global.com).

Subscribing members of BSI are kept up to date with standards developments and receive substantial discounts on the purchase price of standards. For details of these and other benefits contact Membership Administration. Tel: +44 (0)20 8996 7002. Fax: +44 (0)20 8996 7001. Email: [membership@bsi-global.com](mailto:membership@bsi-global.com).

Information regarding online access to British Standards via British Standards Online can be found at <http://www.bsi-global.com/bsonline>.

Further information about BSI is available on the BSI website at <http://www.bsi-global.com>.

### Copyright

Copyright subsists in all BSI publications. BSI also holds the copyright, in the UK, of the publications of the international standardization bodies. Except as permitted under the Copyright, Designs and Patents Act 1988 no extract may be reproduced, stored in a retrieval system or transmitted in any form or by any means – electronic, photocopying, recording or otherwise – without prior written permission from BSI.

This does not preclude the free use, in the course of implementing the standard, of necessary details such as symbols, and size, type or grade designations. If these details are to be used for any other purpose than implementation then the prior written permission of BSI must be obtained.

Details and advice can be obtained from the Copyright & Licensing Manager. Tel: +44 (0)20 8996 7070. Fax: +44 (0)20 8996 7553. Email: [copyright@bsi-global.com](mailto:copyright@bsi-global.com).