

**Thermal bridges in
building construction
— Heat flows and
surface temperatures
— Detailed
calculations (ISO
10211:2007)**

ICS 91.120.10

National foreword

This British Standard is the UK implementation of EN ISO 10211:2007. It supersedes BS EN ISO 10211-1:1996 and BS EN ISO 10211-2:2001 which are withdrawn.

The UK participation in its preparation was entrusted to Technical Committee B/540, Energy performance of materials components and buildings.

A list of organizations represented on this committee can be obtained on request to its secretary.

This publication does not purport to include all the necessary provisions of a contract. Users are responsible for its correct application.

Compliance with a British Standard cannot confer immunity from legal obligations.

This British Standard was published under the authority of the Standards Policy and Strategy Committee on 28 February 2009

© BSI 2009

ISBN 978 0 580 64346 0

Amendments/corrigenda issued since publication

Date	Comments

EUROPEAN STANDARD

EN ISO 10211

NORME EUROPÉENNE

EUROPÄISCHE NORM

December 2007

ICS 91.120.10

Supersedes EN ISO 10211-1:1995, EN ISO 10211-2:2001

English Version

Thermal bridges in building construction - Heat flows and surface temperatures - Detailed calculations (ISO 10211:2007)

Ponts thermiques dans les bâtiments - Flux thermiques et températures superficielles - Calculs détaillés (ISO 10211:2007)

Wärmebrücken im Hochbau - Wärmeströme und Oberflächentemperaturen - Detaillierte Berechnungen (ISO 10211:2007)

This European Standard was approved by CEN on 7 December 2007.

CEN members are bound to comply with the CEN/CENELEC Internal Regulations which stipulate the conditions for giving this European Standard the status of a national standard without any alteration. Up-to-date lists and bibliographical references concerning such national standards may be obtained on application to the CEN Management Centre or to any CEN member.

This European Standard exists in three official versions (English, French, German). A version in any other language made by translation under the responsibility of a CEN member into its own language and notified to the CEN Management Centre has the same status as the official versions.

CEN members are the national standards bodies of Austria, Belgium, Bulgaria, Cyprus, Czech Republic, Denmark, Estonia, Finland, France, Germany, Greece, Hungary, Iceland, Ireland, Italy, Latvia, Lithuania, Luxembourg, Malta, Netherlands, Norway, Poland, Portugal, Romania, Slovakia, Slovenia, Spain, Sweden, Switzerland and United Kingdom.



EUROPEAN COMMITTEE FOR STANDARDIZATION
COMITÉ EUROPÉEN DE NORMALISATION
EUROPÄISCHES KOMITEE FÜR NORMUNG

Management Centre: rue de Stassart, 36 B-1050 Brussels

Foreword

This document (EN ISO 10211:2007) has been prepared by Technical Committee ISO/TC 163 "Thermal performance and energy use in the built environment" in collaboration with Technical Committee CEN/TC 89 "Thermal performance of buildings and building components", the secretariat of which is held by SIS.

This European Standard shall be given the status of a national standard, either by publication of an identical text or by endorsement, at the latest by June 2008, and conflicting national standards shall be withdrawn at the latest by June 2008.

Attention is drawn to the possibility that some of the elements of this document may be the subject of patent rights. CEN [and/or CENELEC] shall not be held responsible for identifying any or all such patent rights.

This document supersedes EN ISO 10211-1:1995, EN ISO 10211-2:2001.

According to the CEN/CENELEC Internal Regulations, the national standards organizations of the following countries are bound to implement this European Standard: Austria, Belgium, Bulgaria, Cyprus, Czech Republic, Denmark, Estonia, Finland, France, Germany, Greece, Hungary, Iceland, Ireland, Italy, Latvia, Lithuania, Luxembourg, Malta, Netherlands, Norway, Poland, Portugal, Romania, Slovakia, Slovenia, Spain, Sweden, Switzerland and the United Kingdom.

Endorsement notice

The text of ISO 10211:2007 has been approved by CEN as a EN ISO 10211:2007 without any modification.

Contents

Page

Foreword.....	v
Introduction	vi
1 Scope	1
2 Normative references	1
3 Terms, definitions, symbols, units and subscripts.....	2
3.1 Terms and definitions	2
3.2 Symbols and units.....	6
3.3 Subscripts	7
4 Principles.....	7
5 Modelling of the construction	7
5.1 Dimension systems	7
5.2 Rules for modelling	7
5.3 Conditions for simplifying the geometrical model.....	13
6 Input data.....	17
6.1 General.....	17
6.2 Thermal conductivities of materials	18
6.3 Surface resistances	18
6.4 Boundary temperatures	18
6.5 Thermal conductivity of quasi-homogeneous layers	18
6.6 Equivalent thermal conductivity of air cavities	18
6.7 Determining the temperature in an adjacent unheated room	19
7 Calculation method.....	19
7.1 Solution technique.....	19
7.2 Calculation rules.....	19
8 Determination of thermal coupling coefficients and heat flow rate from 3-D calculations	20
8.1 Two boundary temperatures, unpartitioned model.....	20
8.2 Two boundary temperatures, partitioned model	20
8.3 More than two boundary temperatures	21
9 Calculations using linear and point thermal transmittances from 3-D calculations	21
9.1 Calculation of thermal coupling coefficient.....	21
9.2 Calculation of linear and point thermal transmittances	22
10 Determination of thermal coupling coefficient, heat flow rate and linear thermal transmittance from 2-D calculations.....	23
10.1 Two boundary temperatures	23
10.2 More than two boundary temperatures	23
10.3 Determination of the linear thermal transmittance	23
10.4 Determination of the linear thermal transmittance for wall/floor junctions.....	24
10.5 Determination of the external periodic heat transfer coefficient for ground floors	25
11 Determination of the temperature at the internal surface	26
11.1 Determination of the temperature at the internal surface from 3-D calculations	26
11.2 Determination of the temperature at the internal surface from 2-D calculations	27
12 Input and output data	28
12.1 Input data.....	28
12.2 Output data.....	28
Annex A (normative) Validation of calculation methods	30

Annex B (informative) Examples of the determination of the linear and point thermal transmittances	37
Annex C (informative) Determination of values of thermal coupling coefficient and temperature weighting factor for more than two boundary temperatures	40
Bibliography	45

Foreword

ISO (the International Organization for Standardization) is a worldwide federation of national standards bodies (ISO member bodies). The work of preparing International Standards is normally carried out through ISO technical committees. Each member body interested in a subject for which a technical committee has been established has the right to be represented on that committee. International organizations, governmental and non-governmental, in liaison with ISO, also take part in the work. ISO collaborates closely with the International Electrotechnical Commission (IEC) on all matters of electrotechnical standardization.

International Standards are drafted in accordance with the rules given in the ISO/IEC Directives, Part 2.

The main task of technical committees is to prepare International Standards. Draft International Standards adopted by the technical committees are circulated to the member bodies for voting. Publication as an International Standard requires approval by at least 75 % of the member bodies casting a vote.

Attention is drawn to the possibility that some of the elements of this document may be the subject of patent rights. ISO shall not be held responsible for identifying any or all such patent rights.

ISO 10211 was prepared by Technical Committee ISO/TC 163, *Thermal performance and energy use in the built environment*, Subcommittee SC 2, *Calculation methods*.

This first edition of ISO 10211 cancels and replaces ISO 10211-1:1995 and ISO 10211-2:2001, which have been technically revised.

The principal changes are as follows:

- this first edition of ISO 10211 merges the title and general contents of ISO 10211-1:1995 and ISO 10211-2:2001 into a single document;
- Clause 3 indicates that ISO 10211 now uses only temperature factor, and not temperature difference ratio;
- 5.2.2 specifies that cut-off planes are to be located at the larger of 1 m and three times the thickness of the flanking element;
- 5.2.4 contains a revised version of Table 1 to correct error for three-dimensional calculations and to clarify intentions;
- 5.2.7 specifies that acceptable criterion is either on heat flow or on surface temperature; the heat flow criterion has been changed from 2 % to 1 %;
- 6.3 specifies that surface resistance values are to be obtained from ISO 6946 for heat flow calculations and from ISO 13788 for condensation calculations; the contents of Annexes E and G of ISO 10211-1:1995 have been deleted in favour of references to ISO 13788;
- 6.6 specifies that data for air cavities is obtained from ISO 6946, EN 673 or ISO 10077-2; the contents of Annex B of ISO 10211-1:1995 have been deleted in favour of these references;
- 10.4 contains text formerly in ISO 13370, revised to specify that linear thermal transmittance values for wall/floor junctions are the difference between the numerical result and the result from using ISO 13370 (a more consistent definition);
- Annex A contains corrections to results for case 3; the conformity criterion for case 3 has been changed from 2 % of heat flow to 1 %; a new case 4 has been added;
- Annex C contains a corrected procedure;
- all remaining annexes from ISO 10211-1:1995 and ISO 10211-2:2001 have been deleted.

Introduction

Thermal bridges, which in general occur at any junction between building components or where the building structure changes composition, have two consequences compared with those of the unbridged structure:

- a) a change in heat flow rate, and
- b) a change in internal surface temperature.

Although similar calculation procedures are used, the procedures are not identical for the calculation of heat flows and of surface temperatures.

A thermal bridge usually gives rise to three-dimensional or two-dimensional heat flows, which can be precisely determined using detailed numerical calculation methods as described in this International Standard.

In many applications, numerical calculations based on a two-dimensional representation of the heat flows provide results of adequate accuracy, especially when the constructional element is uniform in one direction.

A discussion of other methods for assessing the effect of thermal bridges is provided in ISO 14683.

ISO 10211 was originally published in two parts, dealing with three-dimensional and two-dimensional calculations separately.

Thermal bridges in building construction — Heat flows and surface temperatures — Detailed calculations

1 Scope

This International Standard sets out the specifications for a three-dimensional and a two-dimensional geometrical model of a thermal bridge for the numerical calculation of:

- heat flows, in order to assess the overall heat loss from a building or part of it;
- minimum surface temperatures, in order to assess the risk of surface condensation.

These specifications include the geometrical boundaries and subdivisions of the model, the thermal boundary conditions, and the thermal values and relationships to be used.

This International Standard is based upon the following assumptions:

- all physical properties are independent of temperature;
- there are no heat sources within the building element.

This International Standard can also be used for the derivation of linear and point thermal transmittances and of surface temperature factors.

2 Normative references

The following referenced documents are indispensable for the application of this document. For dated references, only the edition cited applies. For undated references, the latest edition of the referenced document (including any amendments) applies.

ISO 6946, *Building components and building elements — Thermal resistance and thermal transmittance — Calculation method*

ISO 7345, *Thermal insulation — Physical quantities and definitions*

ISO 13370:2007, *Thermal performance of buildings — Heat transfer via the ground — Calculation methods*

ISO 13788, *Hygrothermal performance of building components and building elements — Internal surface temperature to avoid critical surface humidity and interstitial condensation — Calculation methods*

3 Terms, definitions, symbols, units and subscripts

3.1 Terms and definitions

For the purposes of this document, the terms and definitions given in ISO 7345 and the following apply.

3.1.1

thermal bridge

part of the building envelope where the otherwise uniform thermal resistance is significantly changed by full or partial penetration of the building envelope by materials with a different thermal conductivity, and/or a change in thickness of the fabric, and/or a difference between internal and external areas, such as occur at wall/floor/ceiling junctions

3.1.2

linear thermal bridge

thermal bridge with a uniform cross-section along one of the three orthogonal axes

3.1.3

point thermal bridge

localized thermal bridge whose influence can be represented by a point thermal transmittance

3.1.4

three-dimensional geometrical model

3-D geometrical model

geometrical model, deduced from building plans, such that for each of the orthogonal axes the cross-section perpendicular to that axis changes within the boundary of the model

See Figure 1.

3.1.5

three-dimensional flanking element

3-D flanking element

part of a 3-D geometrical model which, when considered in isolation, can be represented by a 2-D geometrical model

See Figures 1 and 2.

3.1.6

three-dimensional central element

3-D central element

part of a 3-D geometrical model which is not a 3-D flanking element

See Figure 1.

NOTE A central element is represented by a 3-D geometrical model.

3.1.7

two-dimensional geometrical model

2-D geometrical model

geometrical model, deduced from building plans, such that for one of the orthogonal axes the cross-section perpendicular to that axis does not change within the boundaries of the model

See Figure 2.

NOTE A 2-D geometrical model is used for two-dimensional calculations.

3.1.8

two-dimensional flanking element

2-D flanking element

part of a 2-D geometrical model which, when considered in isolation, consists of plane, parallel material layers

3.1.9

two-dimensional central element

2-D central element

part of a 2-D geometrical model which is not a 2-D flanking element

3.1.10

construction planes

planes in the 3-D or 2-D geometrical model which separate different materials, and/or the geometrical model from the remainder of the construction, and/or the flanking elements from the central element

See Figure 3.

3.1.11

cut-off planes

construction planes that are boundaries to the 3-D or 2-D geometrical model by separating the model from the remainder of the construction

See Figure 3.

3.1.12

auxiliary planes

planes which, in addition to the construction planes, divide the geometrical model into a number of cells

3.1.13

quasi-homogeneous layer

layer which consists of two or more materials with different thermal conductivities, but which can be considered as a homogeneous layer with an effective thermal conductivity

See Figure 4.

3.1.14

temperature factor at the internal surface

difference between internal surface temperature and external temperature, divided by the difference between internal temperature and external temperature, calculated with a surface resistance R_{si} at the internal surface

3.1.15

temperature weighting factor

weighting factor which states the respective influence of the temperatures of the different thermal environments upon the surface temperature at the point under consideration

3.1.16

external boundary temperature

external air temperature, assuming that the air temperature and the radiant temperature seen by the surface are equal

3.1.17

internal boundary temperature

operative temperature, taken for the purposes of this International Standard as the arithmetic mean value of internal air temperature and mean radiant temperature of all surfaces surrounding the internal environment

3.1.18

thermal coupling coefficient

heat flow rate per temperature difference between two environments which are thermally connected by the construction under consideration

3.1.19

linear thermal transmittance

heat flow rate in the steady state divided by length and by the temperature difference between the environments on either side of a thermal bridge

NOTE The linear thermal transmittance is a quantity describing the influence of a linear thermal bridge on the total heat flow.

3.1.20

point thermal transmittance

heat flow rate in the steady state divided by the temperature difference between the environments on either side of a thermal bridge

NOTE The point thermal transmittance is a quantity describing the influence of a point thermal bridge on the total heat flow.

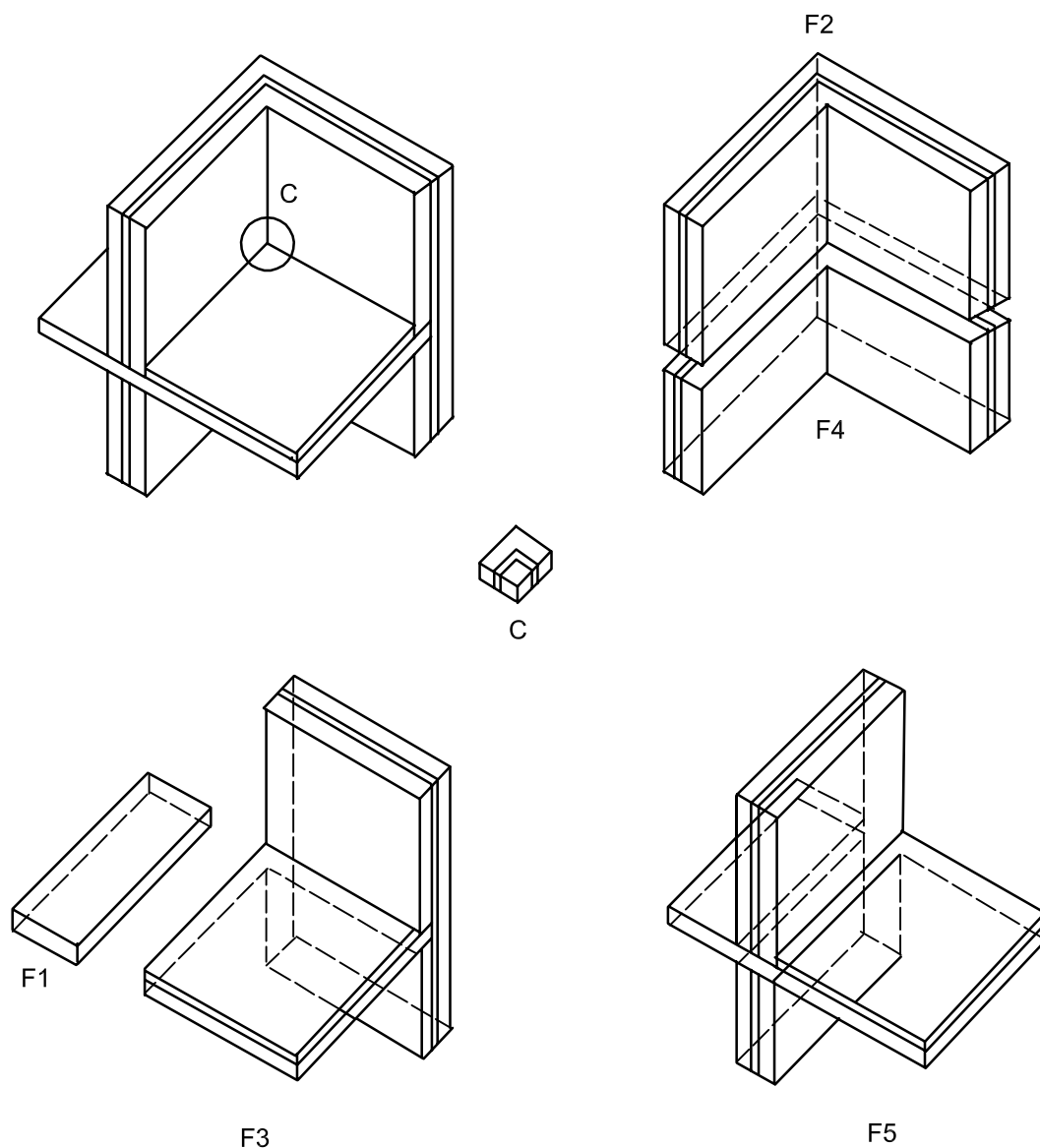

Key

F1, F2, F3, F4, F5 3-D flanking elements

C 3-D central element

NOTE 3-D Flanking elements have constant cross-sections perpendicular to at least one axis; the 3-D central element is the remaining part.

Figure 1 — 3-D geometrical model with five 3-D flanking elements and one 3-D central element

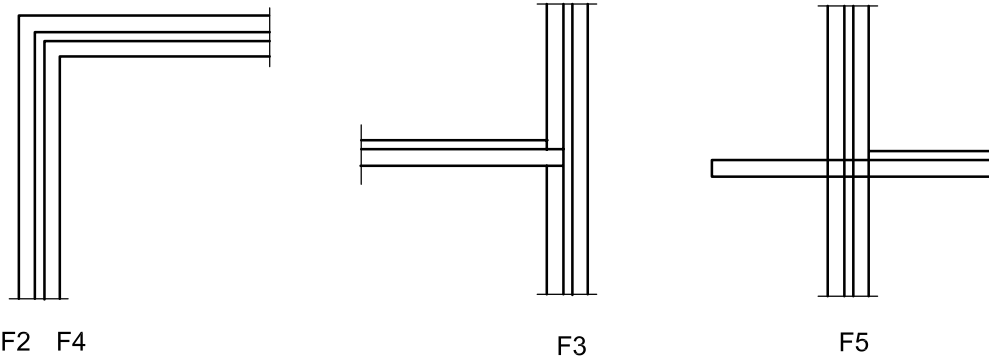

Key

F2, F3, F4, F5 3-D flanking elements

C 3-D central element

NOTE F2 to F5 refer to Figure 1.

Figure 2 — Cross-sections of the 3-D flanking elements in a 3-D geometrical model treated as 2-D geometrical models

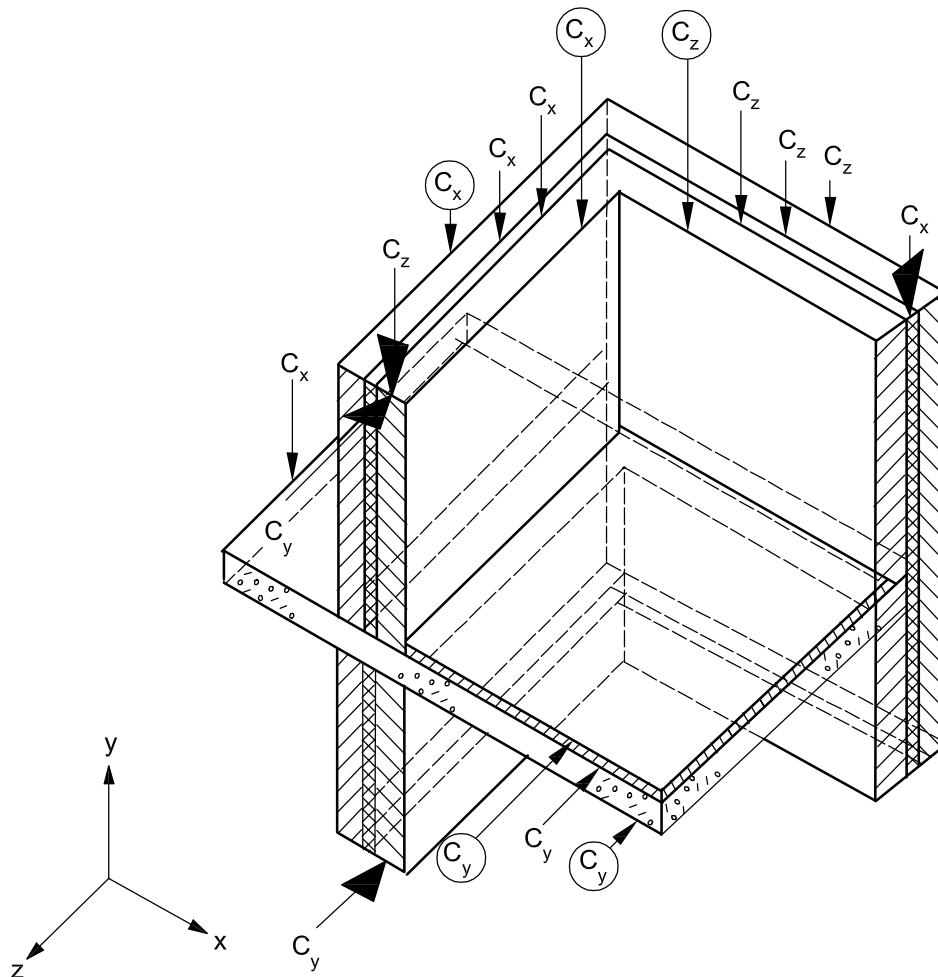

Key

C_x construction planes perpendicular to the x-axis

C_y construction planes perpendicular to the y-axis

C_z construction planes perpendicular to the z-axis

NOTE Cut-off planes are indicated with enlarged arrows; planes that separate flanking elements from central element are encircled.

Figure 3 — Example of a 3-D geometrical model showing construction planes

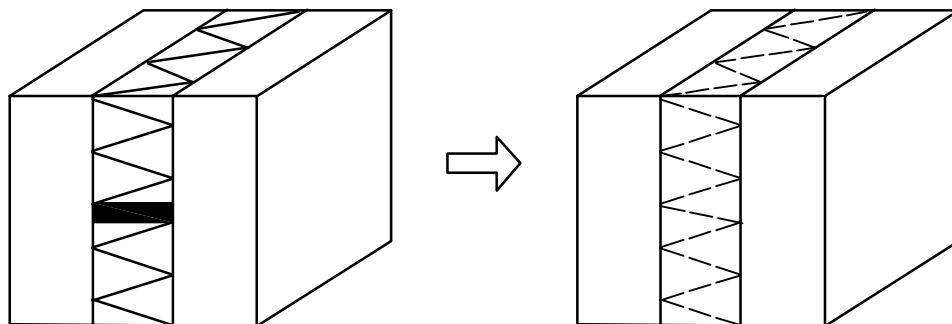

Figure 4 — Example of a minor point thermal bridge giving rise to three-dimensional heat flow, incorporated into a quasi-homogeneous layer

3.2 Symbols and units

Symbol	Quantity	Unit
A	area	m^2
B'	characteristic dimension of floor	m
b	width	m
d	thickness	m
f_{Rsi}	temperature factor at the internal surface	—
g	temperature weighting factor	—
h	height	m
L_{2D}	thermal coupling coefficient from two-dimensional calculation	$W/(m \cdot K)$
L_{3D}	thermal coupling coefficient from three-dimensional calculation	W/K
l	length	m
q	density of heat flow rate	W/m^2
R	thermal resistance	$m^2 \cdot K/W$
R_{se}	external surface resistance	$m^2 \cdot K/W$
R_{si}	internal surface resistance	$m^2 \cdot K/W$
T	thermodynamic temperature	K
U	thermal transmittance	$W/(m^2 \cdot K)$
V	volume	m^3
w	wall thickness	m
Φ	heat flow rate	W
λ	thermal conductivity	$W/(m \cdot K)$
θ	Celsius temperature	$^{\circ}C$
$\Delta\theta$	temperature difference	K
χ	point thermal transmittance	W/K
Ψ	linear thermal transmittance	$W/(m \cdot K)$

3.3 Subscripts

Subscript	Definition
e	external
i	internal
min	minimum
s	surface

4 Principles

The temperature distribution within, and the heat flow through, a construction can be calculated if the boundary conditions and constructional details are known. For this purpose, the geometrical model is divided into a number of adjacent material cells, each with a homogeneous thermal conductivity. The criteria which shall be met when constructing the model are given in Clause 5.

In Clause 6, instructions are given for the determination of the values of thermal conductivity and boundary conditions.

The temperature distribution is determined either by means of an iterative calculation or by a direct solution technique, after which the temperature distribution within the material cells is determined by interpolation. The calculation rules and the method of determining the temperature distribution are described in Clause 7.

The results of the calculations can be used to determine linear thermal transmittances, point thermal transmittances and internal surface temperatures. The equations for doing so are provided in Clauses 9, 10 and 11.

Specific procedures for window frames are given in ISO 10077-2.

5 Modelling of the construction

5.1 Dimension systems

Lengths may be measured using internal dimensions, overall internal dimensions or external dimensions, provided that the same system is used consistently for all parts of a building.

NOTE For further information on dimension systems, see ISO 13789.

5.2 Rules for modelling

5.2.1 General

It is not usually feasible to model a complete building using a single geometrical model. In most cases, the building may be partitioned into several parts (including the subsoil, where appropriate) by using cut-off planes. This partitioning shall be performed in such a way that all differences are avoided in the results of calculation between the partitioned building and the building when treated as a whole. This partitioning into several geometrical models is achieved by choosing suitable cut-off planes.

5.2.2 Cut-off planes for a 3-D geometrical model for calculation of total heat flow and/or surface temperatures

The geometrical model includes the central element(s), the flanking elements and, where appropriate, the subsoil. The geometrical model is delimited by cut-off planes.

Cut-off planes shall be positioned as follows:

- at a symmetry plane if this is less than d_{\min} from the central element (see Figure 5);
- at least d_{\min} from the central element if there is no nearer symmetry plane (see Figure 6);
- in the ground, in accordance with 5.2.4,

where d_{\min} is the greater of 1 m and three times the thickness of the flanking element concerned.

A geometrical model can contain more than one thermal bridge. In such cases, cut-off planes need to be situated at least d_{\min} from each thermal bridge, or need to be at a symmetry plane (see Figure 6).

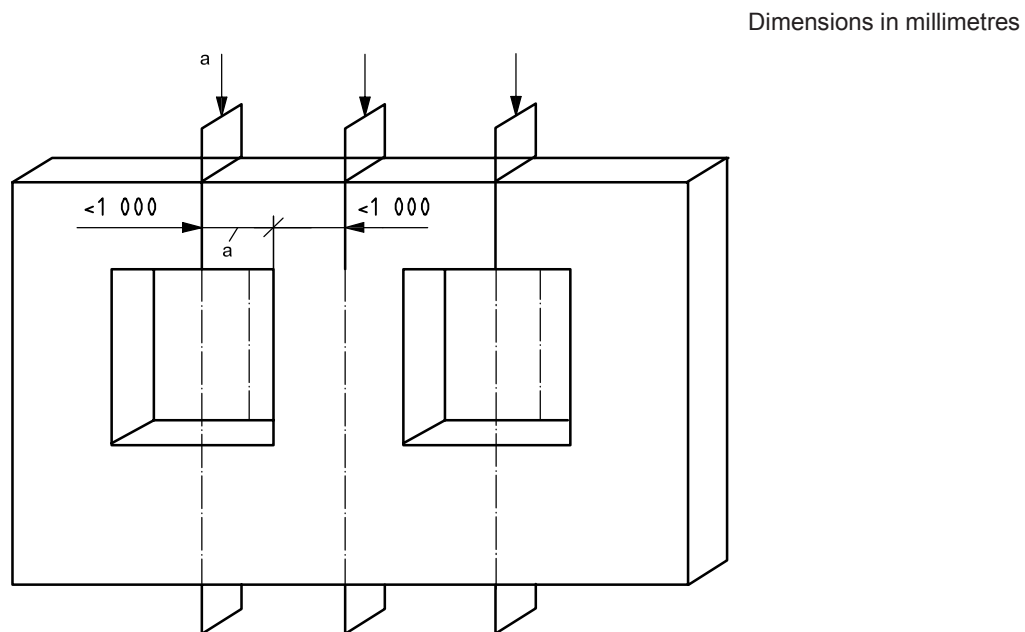

a Arrows indicate the symmetry planes.

Figure 5 — Symmetry planes which can be used as cut-off planes

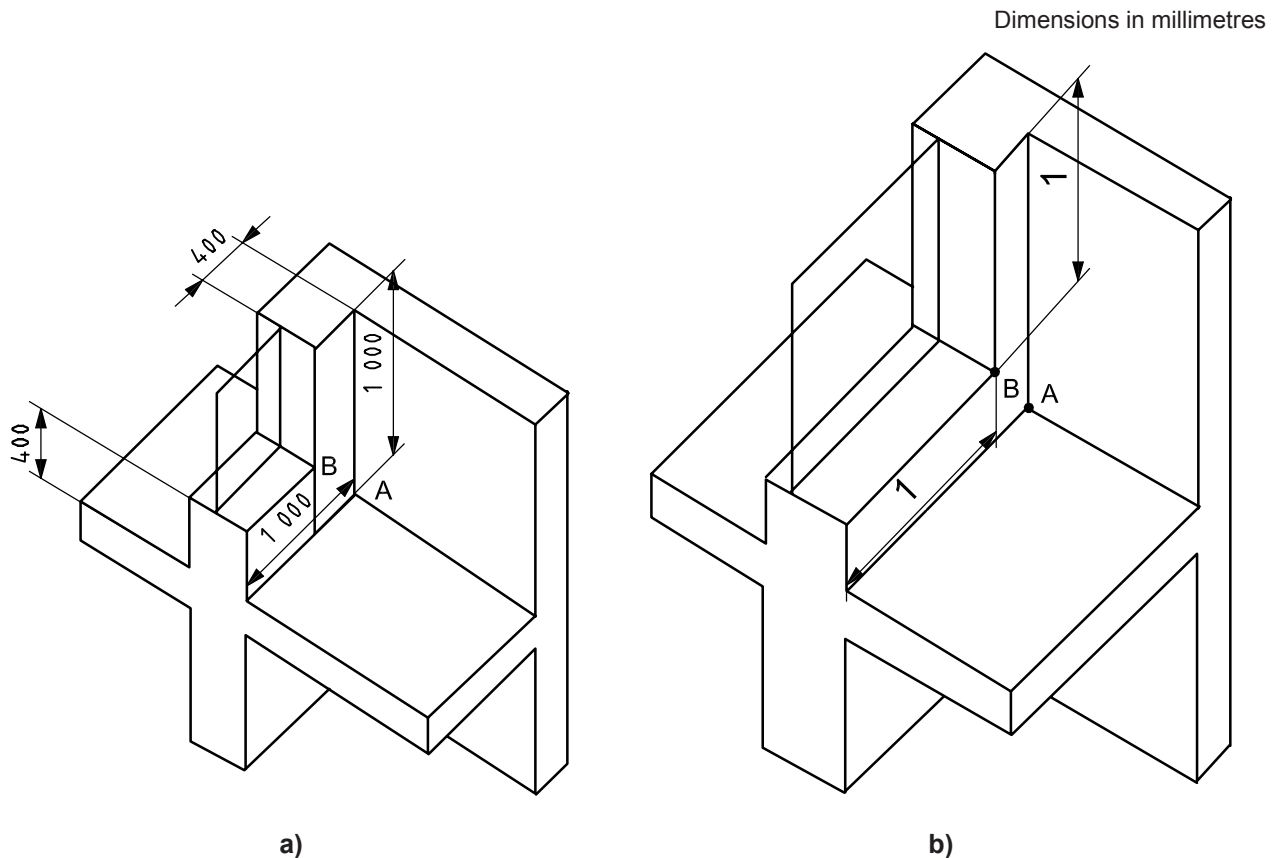

Key

- 1 1 000 mm or at a symmetry plane
- A thermal bridge at the corner of the internal room
- B thermal bridge around the window in the external wall

NOTE Thermal bridge B does not fulfil the condition of being at least d_{\min} (= 1 m) from a cut-off plane [Figure 6 a)]. This is corrected by extending the model in two directions [Figure 6 b)].

Figure 6 — 3-D geometrical model containing two thermal bridges

5.2.3 Cut-off planes for a 2-D geometrical model

The same rules as given in 5.2.2 apply to a 2-D geometrical model. Examples are shown in Figures 7 and 8. In Figure 8, the left-hand drawing may be used if the thermal bridge is symmetrical.

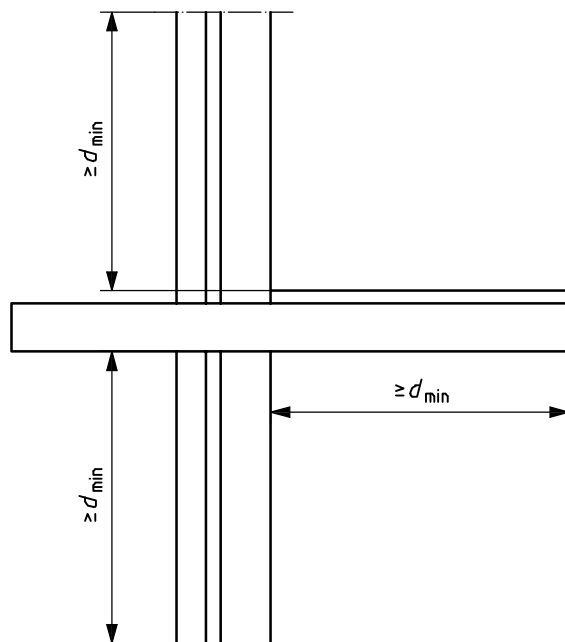

Key
 d_{\min} minimum thickness

Figure 7 — Location of cut-off planes at least d_{\min} from the central element in a 2-D geometrical model

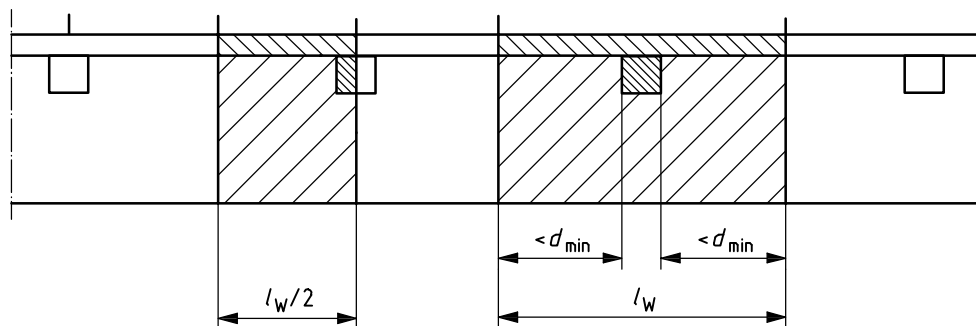

Key
 d_{\min} minimum thickness
 l_W fixed distance

Figure 8 — Example of a construction with linear thermal bridges at fixed distances, l_W , showing symmetry planes which can be used as cut-off planes

5.2.4 Cut-off planes in the ground

Where the calculation involves heat transfer via the ground (foundations, ground floors, basements), the cut-off planes in the ground shall be positioned as indicated in Table 1.

Table 1 — Location of cut-off planes in the ground

Direction	Distance to central element	
	Purpose of the calculation	
	Surface temperatures only	Heat flow and surface temperatures ^a
Horizontal distance to vertical plane, inside the building	at least three times wall thickness	$0,5 \times \text{floor dimension}^b$
Horizontal distance to vertical plane, outside the building	at least three times wall thickness	$2,5 \times \text{floor width}^{c, d}$
Vertical distance to horizontal plane below ground level	at least 3 m	$2,5 \times \text{floor width}^c$
Vertical distance to horizontal plane below floor level (applies only if the level of the floor under consideration is more than 2 m below the ground level)	at least 1 m	$2,5 \times \text{floor width}^c$
<p>^a See Figures 9 and 10.</p> <p>^b In a 3-D geometrical model, the floor dimensions (length and width) inside the building are to be considered separately in each direction (see Figure 9).</p> <p>^c In a 3-D geometrical model, the distance outside the building and below ground is to be based on the smaller dimension (width) of the floor (see Figure 9).</p> <p>^d If vertical symmetry planes are known, for example as a result of adjacent buildings, they can be used as cut-off planes.</p>		

For two-dimensional calculations, there is a vertical symmetry plane in the middle of the floor (so that one half of the building is modelled). For three-dimensional calculations on a rectangular building, vertical adiabatic boundaries are taken in the ground mid-way across the floor in each direction (so that one quarter of the building is modelled). For non-rectangular buildings, it is necessary either to model the complete building (together with the ground on all sides), or to convert the problem to a two-dimensional one using a building of infinite length and of width equal to the characteristic dimension of the floor, B' (see ISO 13370).

EXAMPLE For the floor illustrated in Figure 9, $B' = bc/(b + c)$.

All cut-off planes shall be adiabatic boundaries.

5.2.5 Periodic heat flows via the ground

Similar criteria to those in 5.2.4 apply to time-dependent numerical calculations for the determination of periodic heat transfer coefficients (as defined in ISO 13370), except that adiabatic cut-off planes may be taken at positions equal to twice the periodic penetration depth measured from the edge of the floor in any direction (if these dimensions are less than those specified in 5.2.4). For further details, see 10.5.

5.2.6 Adjustments to dimensions

Adjustments to the dimensions of the geometrical model with respect to the actual geometry are allowed if they have no significant influence on the result of the calculation; this can be assumed if the conditions in 5.3.2 are satisfied.

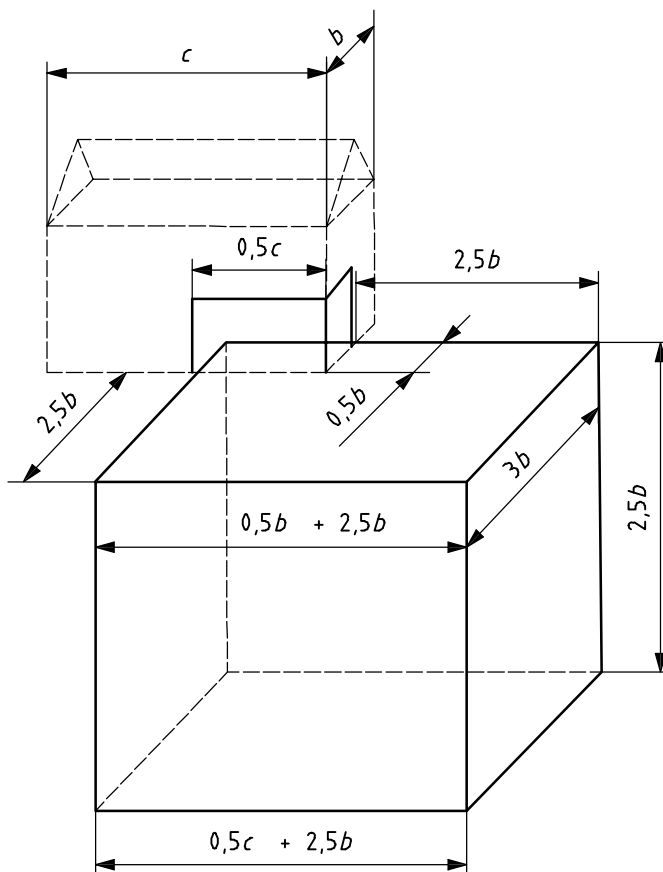

Key

b, c dimensions of floor

NOTE The floor dimensions are $b \times c$, with $c > b$

Figure 9 — Illustration of cut-off planes for 3-D geometrical model which includes the ground

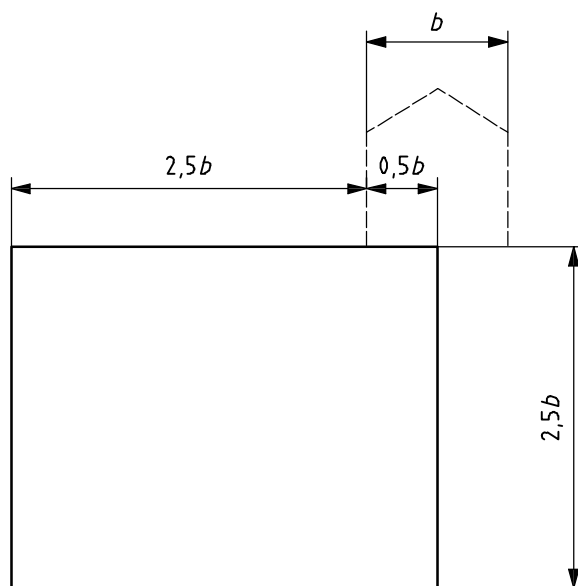

Key

b width of floor

Figure 10 — Illustration of cut-off planes for 2-D geometrical model which includes the ground

5.2.7 Auxiliary planes

The number of auxiliary planes in the model shall be such that at least one of the following criteria is met:

- doubling the number of subdivisions does not change the calculated heat flow through by more than 1 %, or
- doubling the number of subdivisions does not change the temperature factor at the inside surface, f_{Rsi} , by more than 0,005.

NOTE 1 Requirements for validation of calculation methods are given in A.2.

NOTE 2 A satisfactory sub-division of the geometrical model will usually be obtained by arranging for the sub-divisions to be smallest within any central element, and gradually increasing in size to larger sub-divisions near cut-off planes.

5.2.8 Quasi-homogeneous layers and materials

In a geometrical model, materials with different thermal conductivities may be replaced by a material with a single thermal conductivity if the conditions in 5.3.3 are satisfied.

NOTE Examples are joints in masonry, wall-ties in thermally insulated cavities, screws in wooden laths, roof tiles and the associated air cavity and tile battens.

5.3 Conditions for simplifying the geometrical model

5.3.1 General

Calculation results obtained from a geometrical model with no simplifications shall have precedence over those obtained from a geometrical model with simplifications.

NOTE This is important when the results of a calculation are close to any required value.

The adjustments described in 5.3.2 can be made.

5.3.2 Conditions for adjusting dimensions to simplify the geometrical model

Adjustment to the dimensions may be made only to materials with thermal conductivity less than 3 W/(m·K), as described below.

- a) Change in the location of the surface of a block of material adjacent to the internal or external surface of the geometrical model (see Figure 11): for the location of surfaces which are not flat, the local adjustment perpendicular to the mean location of the internal or external surface, d_c , shall not exceed

$$d_c = R_c \lambda \quad (1)$$

where

R_c is equal to 0,03 m²·K/W;

λ is the thermal conductivity of the material in question.

EXAMPLE Inclined surfaces, rounded edges and profiled surfaces such as roof tiles.

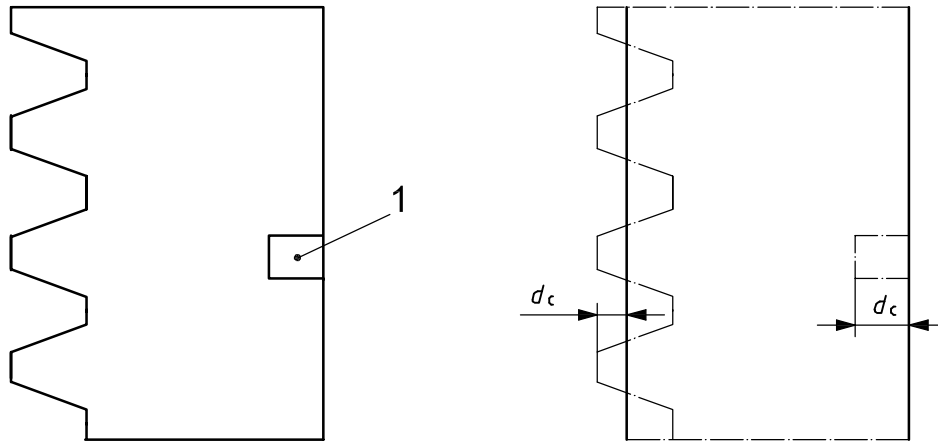

Key

- 1 wall socket
- d_c local adjustment perpendicular to the mean location of the internal or external surface

Figure 11 — Change in the location of the internal or external surface

b) Change in the interface of two regions of different material:

- the relocation of the interface shall take place in a direction perpendicular to the internal surface;
- the relocation of the interface shall be such that the material with the lower thermal conductivity is replaced by the material with the higher thermal conductivity (see Figure 12).

EXAMPLE Recesses for sealing strips, kit joints, adjusting blocks, wall sockets, inclined surfaces and other connecting details.

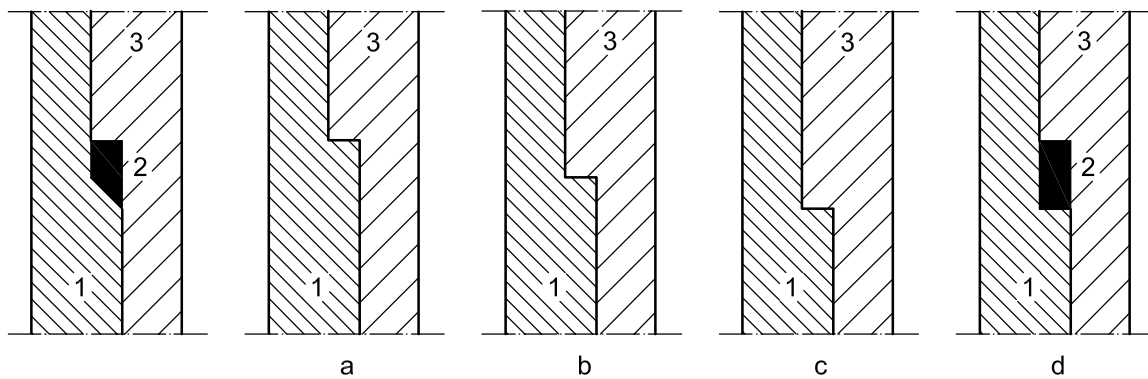

Combination		Simplifications			
Material block	Thermal conductivity	a	b	c	d
1	λ_1	$\lambda_1 > \lambda_2$	$\lambda_1 > \lambda_3$	$\lambda_1 < \lambda_3$	$\lambda_1 < \lambda_2$
2	λ_2				
3	λ_3		$\lambda_3 > \lambda_2$	$\lambda_3 > \lambda_2$	$\lambda_3 < \lambda_2$

Figure 12 — Four possibilities for relocating the interface between three material blocks, depending on the ratio of their thermal conductivities, λ

c) Neglecting thin layers:

- non-metallic layers with a thickness of not more than 1 mm may be ignored;
- thin metallic layers may be ignored if it is established that they have a negligible effect on the heat transfer.

EXAMPLE Thin membranes which resist the passage of moisture, water vapour or wind-driven air.

d) Neglecting appendages attached to the outside surface: components of the building which have been attached to the outside surface (i.e. attached at discrete points) may be neglected.

EXAMPLE Rainwater gutters and discharge pipes.

5.3.3 Conditions for using quasi-homogeneous material layers to simplify the geometrical model

5.3.3.1 All calculations

The following conditions for incorporating minor linear and point thermal bridges into a quasi-homogeneous layer apply in all cases:

- the layers of material in question are located in a part of the construction which, after simplification, becomes a flanking element;
- the thermal conductivity of the quasi-homogeneous layer after simplification is not more than 1,5 times the lowest thermal conductivity of the materials present in the layer before simplification.

5.3.3.2 Calculations performed to obtain the thermal coupling coefficient L_{3D} or L_{2D}

The effective thermal conductivity of the quasi-homogeneous layer, λ' , shall be calculated in accordance with Equation (2) or (3):

$$\lambda' = \frac{d}{\frac{A}{L_{3D}} - R_{si} - R_{se} - \sum \frac{d_j}{\lambda_j}} \quad (2)$$

$$\lambda' = \frac{d}{\frac{l_{tb}}{L_{2D}} - R_{si} - R_{se} - \sum \frac{d_j}{\lambda_j}} \quad (3)$$

where

d is the thickness of the thermally inhomogeneous layer;

A is the area of the building component;

l_{tb} is the length of a linear thermal bridge;

L_{3D} is the thermal coupling coefficient of the building component determined by a 3-D calculation;

L_{2D} is the thermal coupling coefficient of the building component determined by a 2-D calculation;

d_j is the thickness of any homogeneous layer which is part of the building element;

λ_j are the thermal conductivities of these homogeneous layers.

NOTE The use of Equation (2) or (3) is appropriate if a number of identical minor thermal bridges are present (wall-ties, joints in masonry, hollow blocks, etc.). The calculation of the thermal coupling coefficient can be restricted to a basic area that is representative of the inhomogeneous layer. For instance, a cavity wall with four wall-ties per square metre can be represented by a basic area of 0,25 m² with one wall-tie.

5.3.3.3 Calculations performed to obtain the internal surface temperature or the linear thermal transmittance, Ψ , or the point thermal transmittance, χ

See Clause 9 for calculations using linear and point thermal transmittances from 3-D calculations.

The effective thermal conductivity of the quasi-homogeneous layer, λ' , may be taken as

$$\lambda' = \frac{(A_1\lambda_1 + \dots + A_n\lambda_n)}{(A_1 + \dots + A_n)} \quad (4)$$

where

$\lambda_1, \dots, \lambda_n$ are the thermal conductivities of the constituent materials;

A_1, \dots, A_n are the areas of the constituent materials measured in the plane of the layer,

provided that

- the thermal bridges in the layer under consideration are at, or nearly at, right angles to the internal or external surface of the building element and penetrate the layer over its entire thickness;
- the thermal resistance (surface to surface) of the building element after simplification is at least 1,5 (m²·K)/W;
- the conditions of at least one of the groups stated in Table 2 are met (see Figure 13).

Table 2 — Specific conditions for incorporating linear or point thermal bridges into a quasi-homogeneous layer

Group ^a	λ_{tb} ^b W/(m·K)	A_{tb} ^c m ²	R_0 ^e m ² ·K/W	$R_{t,i}$ ^f m ² ·K/W	λ_i ^g W/(m·K)	d_i ^h m
1	≤ 1,5	≤ 0,05 × l_{tb} ^d	≤ 0,5	—	—	—
2	> 3	≤ 30 × 10 ⁻⁶	≤ 0,5	—	—	—
3	> 3	≤ 30 × 10 ⁻⁶	> 0,5	≥ 0,5	—	—
4	> 3	≤ 30 × 10 ⁻⁶	> 0,5	< 0,5	≥ 0,5	≥ 0,1

NOTE 1 Group 1 includes linear thermal bridges. Examples are joints in masonry, wooden battens in air cavities or in insulated cavities of minor thickness.

NOTE 2 Group 2 includes such items as wall-ties, insofar as they are fitted in masonry or concrete or are located in an air cavity, as well as nails and screws in layers of material or strips with the indicated maximum thermal resistance.

NOTE 3 Groups 3 and 4 include such items as cavity ties, insofar as they penetrate an insulation layer which has a higher thermal resistance than that indicated for group 2. The inner leaf therefore needs to have thermal properties that limit the influence of the thermal bridge on the internal surface temperature, e.g. if the inner leaf has a sufficient thermal resistance (group 3) or the thermal conductivity of the inner leaf is such that the heat flow through the cavity ties is adequately distributed over the internal surface; most masonry or concrete inner leaves are examples of group 4.

^a See Figure 13.

^b λ_{tb} is the thermal conductivity of the thermal bridge to be incorporated into the quasi-homogeneous layer.

^c A_{tb} is the area of the cross-section of the thermal bridge.

^d l_{tb} is the length of a linear thermal bridge.

^e R_0 is the thermal resistance of the layer without the presence of the point thermal bridge.

^f $R_{t,i}$ is the total thermal resistance of the layers between the quasi-homogeneous layer considered and the internal surface.

^g λ_i is the thermal conductivity of the material layer between the quasi-homogeneous layer considered and the internal surface with the highest value of $\lambda_i \cdot d_i$.

^h d_i is the thickness of the same layer.

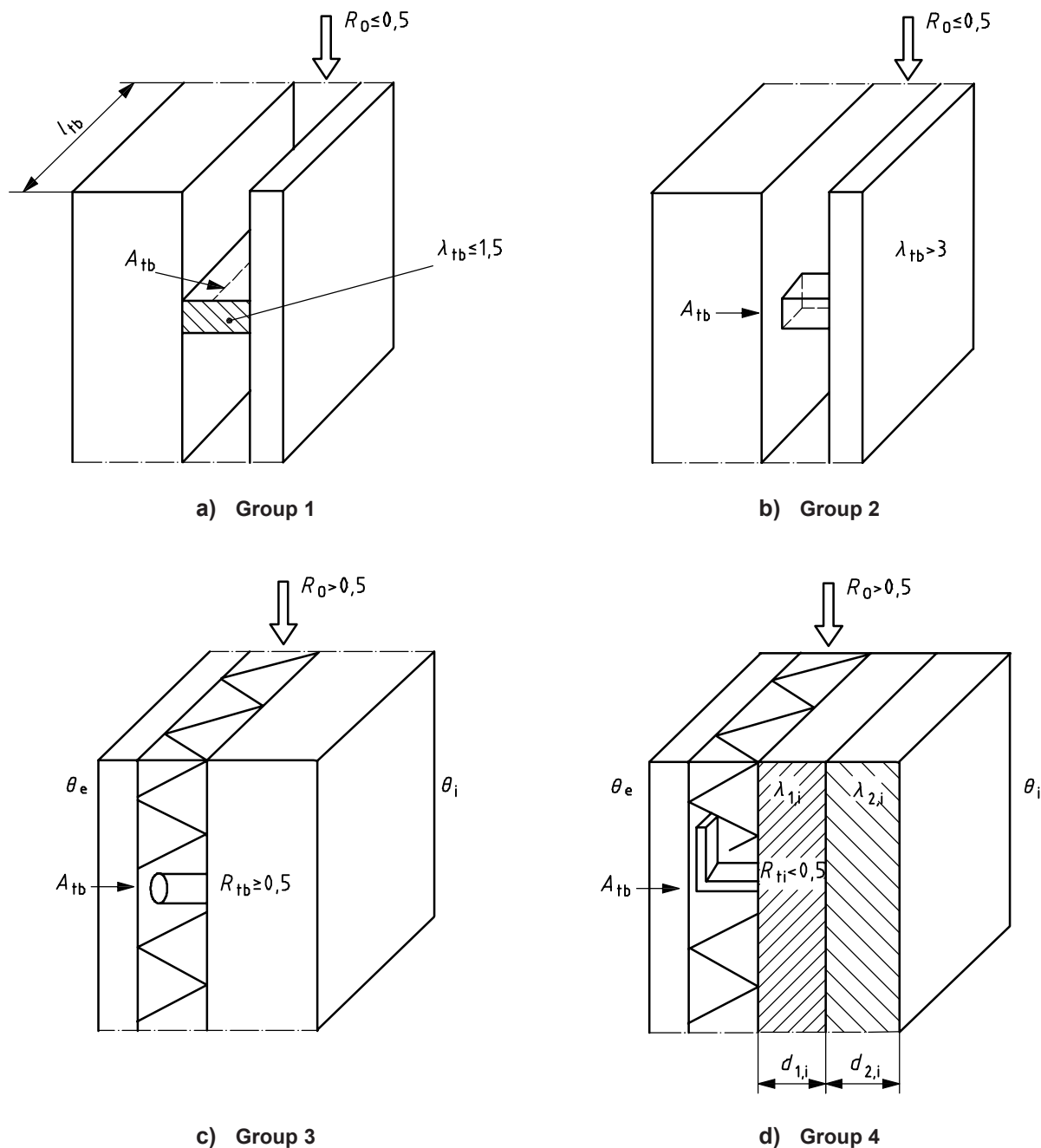

For key of symbols, see Table 2.

Figure 13 — Specific conditions for incorporating linear and point thermal bridges in a quasi-homogeneous layer for the groups given in Table 2

6 Input data

6.1 General

Use values as described in this clause unless non-standard values are justified for a particular situation.

NOTE Non-standard values can be justified by local conditions (e.g. established temperature distributions in the ground) or by specific material properties (e.g. the effect of a low emissivity coating on the surface resistance).

6.2 Thermal conductivities of materials

The design values of thermal conductivities of building materials and products should either be calculated in accordance with ISO 10456, or taken from tabulated values such as in ISO 10456.

The thermal conductivity of soil can be taken as 2,0 W/(m·K).

NOTE Other values for the thermal conductivity of the soil can be used if information on the local soil condition is available (see ISO 13370).

6.3 Surface resistances

For the calculation of heat flow rates, surface resistances shall be in accordance with ISO 6946, depending on the direction of heat flow. However, the value of R_{si} corresponding to horizontal heat flow may be used for all surfaces when

- a) the direction of heat flow is uncertain or is liable to vary, or
- b) a whole building is being modelled in a single calculation.

For the calculation of internal surface temperatures for the purposes of evaluating condensation risk, surface resistances shall be in accordance with ISO 13788.

6.4 Boundary temperatures

Table 3 gives the boundary temperatures which shall be used.

Table 3 — Boundary temperatures

Location	Boundary temperature
Internal	Internal boundary temperature
Internal in unheated rooms	See 6.7
External	External boundary temperature
Soil (horizontal cut-off plane)	At the distance below ground level given in Table 1: adiabatic boundary condition

6.5 Thermal conductivity of quasi-homogeneous layers

The thermal conductivity of quasi-homogeneous layers shall be calculated in accordance with Equations (2), (3) and (4).

6.6 Equivalent thermal conductivity of air cavities

An air cavity shall be considered as a homogeneous conductive material with a thermal conductivity λ_g .

If the thermal resistance of an air layer or cavity is known, its equivalent thermal conductivity, λ_g , is obtained from

$$\lambda_g = \frac{d_g}{R_g} \quad (5)$$

where

d_g is the thickness of the air layer;

R_g is the thermal resistance in the main direction of heat flow.

Thermal resistances of air layers and cavities bounded by opaque materials shall be obtained by the procedure in ISO 6946.

For the thermal resistance of air layers in multiple glazing, see EN 673. Information about the treatment of cavities in window frames is given in ISO 10077-2.

Air cavities with dimensions of more than 0,5 m along each one of the orthogonal axis shall be treated as rooms (see 6.7).

6.7 Determining the temperature in an adjacent unheated room

If sufficient information is available, the temperature in an adjacent unheated room may be calculated in accordance with ISO 13789.

If the temperature in an adjacent unheated room is unknown and cannot be calculated in accordance with ISO 13789 because the necessary information is not available, the heat flows and internal surface temperatures cannot be calculated. However, all required coupling coefficients and temperature weighting factors can be calculated and presented in accordance with Annex C.

7 Calculation method

7.1 Solution technique

The geometrical model is divided into a number of cells, each with a characteristic point (called a node). By applying the laws of energy conservation ($\text{div } q = 0$) and Fourier ($q = -\lambda \text{ grad } \theta$) and taking into account the boundary conditions, a system of equations is obtained which is a function of the temperatures at the nodes. The solution of this system, either by a direct solution technique or by an iterative method, provides the node temperatures from which the temperature field can be determined. From the temperature distribution, the heat flows can be calculated by applying Fourier's law.

Calculation methods shall be verified in accordance with the requirements of Annex A.

7.2 Calculation rules

7.2.1 Heat flows between material cells and adjacent environment

The density of heat flow rate, q , perpendicular to the interface between a material cell and the adjacent environment shall satisfy

$$q = \frac{(\theta - \theta_s)}{R_s} \quad (6)$$

where

θ is the internal or external reference temperature;

θ_s is the temperature at the internal or external surface;

R_s is the internal or external surface resistance.

7.2.2 Heat flows at cut-off planes

The cut-off planes shall be adiabatic (i.e. zero heat flow).

7.2.3 Solution of the equations

The equations shall be solved in accordance with the requirements given in A.2.

7.2.4 Calculation of the temperature distribution

The temperature distribution within each material cell shall be calculated by interpolation between the node temperatures.

NOTE Linear interpolation suffices.

8 Determination of thermal coupling coefficients and heat flow rate from 3-D calculations

8.1 Two boundary temperatures, unpartitioned model

If there are only two environments with two different temperatures (e.g. one internal and one external temperature), and if the total room or building is calculated three-dimensionally from a single model, then the total thermal coupling coefficient, $L_{3D,1,2}$, can be obtained from the total heat flow rate, Φ , of the room or building, as follows:

$$\Phi = L_{3D,1,2}(\theta_1 - \theta_2) \quad (7)$$

8.2 Two boundary temperatures, partitioned model

If the room or building has been partitioned (see Figure 14), the total $L_{3D,i,j}$ value is calculated from Equation (8):

$$L_{3D,i,j} = \sum_{k=1}^{N_k} U_{k(i,j)} \cdot A_k + \sum_{m=1}^{N_m} L_{2D,m(i,j)} \cdot l_m + \sum_{n=1}^{N_n} L_{3D,n(i,j)} \quad (8)$$

where

$L_{3D,n(i,j)}$ is the thermal coupling coefficient obtained from a 3-D calculation for part n of the room or building;

$L_{2D,m(i,j)}$ is the thermal coupling coefficient obtained from a 2-D calculation for part m of the room or building;

l_m is the length over which the value $L_{2D,m(i,j)}$ applies;

$U_{k(i,j)}$ is the thermal transmittance obtained from a 1-D calculation for part k of the room or building;

A_k is the area over which the value U_k applies;

N_n is the total number of 3-D parts;

N_m is the total number of 2-D parts;

N_k is the total number of 1-D parts.

NOTE In Equation (8), $\sum A_k$ is less than the total surface area of the envelope because some of the surface area is included in the 2-D and 3-D terms.

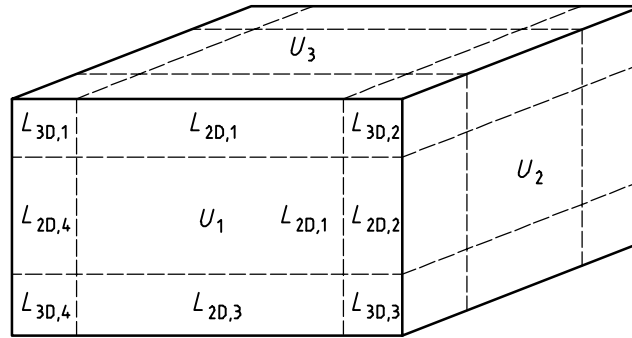

Figure 14 — Building envelope partitioned into 3-D, 2-D and 1-D geometrical models

8.3 More than two boundary temperatures

The heat flow rate, $\Phi_{i,j}$, from environment i to a thermally connected environment j is given by

$$\Phi_{i,j} = L_{3D,i,j}(\theta_i - \theta_j) \quad (9)$$

The total heat flow rate from a room or building can be calculated using the principles as stated in Clause 4. The heat flow rate to/from a room at temperature θ_i can be calculated from

$$\Phi = \sum_j [L_{3D,i,j}(\theta_i - \theta_j)] \quad (10)$$

where

$L_{3D,i,j}$ are the coupling coefficients between the room and adjacent rooms or external environments;

θ_j are the temperatures of adjacent rooms or external environments.

The total heat flow rate to/from a building can be calculated from

$$\Phi = \sum_i \sum_j [L_{3D,i,j}(\theta_i - \theta_j)] \quad (11)$$

where

θ_i are the temperatures of internal rooms;

θ_j are the temperatures of external environments;

$L_{3D,i,j}$ are the corresponding coupling coefficients.

NOTE C.1 provides a method to calculate the thermal coupling coefficients.

9 Calculations using linear and point thermal transmittances from 3-D calculations

9.1 Calculation of thermal coupling coefficient

The relationship between $L_{3D,i,j}$ and thermal transmittances is given by

$$L_{3D,i,j} = \sum_{k=1}^{N_k} U_{k(i,j)} \cdot A_k + \sum_{m=1}^{N_m} \Psi_{m(i,j)} \cdot l_m + \sum_{n=1}^{N_n} \chi_{n(i,j)} \quad (12)$$

where

- $U_{k(i,j)}$ is the thermal transmittance of part k of the room or building;
- A_k is the area over which the value $U_{k(i,j)}$ applies;
- $\Psi_{m(i,j)}$ is the linear thermal transmittance of part m of the room or building;
- l_m is the length over which the value $\Psi_{m(i,j)}$ applies;
- $\chi_{n(i,j)}$ is the point thermal transmittance of part n of the room or building;
- N_k is the number of thermal transmittances;
- N_m is the number of linear thermal transmittances;
- N_n is the number of point thermal transmittances.

NOTE 1 In Equation (12), ΣA_k is equal to the total surface area of the envelope.

NOTE 2 $L_{3D,i,j}$ is equivalent to the heat transfer coefficient, H , used in other standards.

9.2 Calculation of linear and point thermal transmittances

Ψ values are determined from

$$\Psi = L_{2D} - \sum_{j=1}^{N_j} U_j \cdot l_j \quad (13)$$

where

- L_{2D} is the thermal coupling coefficient obtained from a 2-D calculation of the component separating the two environments being considered;
- U_j is the thermal transmittance of the 1-D component, j , separating the two environments being considered;
- l_j is the length over which the value U_j applies.

χ values are determined from

$$\chi = L_{3D} - \sum_{i=1}^{N_i} U_i \cdot A_i - \sum_{j=1}^{N_j} \Psi_j \cdot l_j \quad (14)$$

where

- L_{3D} is the thermal coupling coefficient obtained from a 3-D calculation of the 3-D component separating the two environments being considered;
- U_i is the thermal transmittance of the 1-D component i separating the two environments being considered;
- A_i is the area over which the value U_i applies;
- Ψ_j are linear thermal transmittances calculated using Equation (18);
- l_j is the length over which the value Ψ_j applies;

N_j is the number of 2-D components;

N_i is the number of 1-D components.

When determining Ψ and χ values, it is necessary to state which dimensions (e.g. internal or external) are being used, because for several types of thermal bridges, the Ψ and χ values depend on this choice.

NOTE Annex B provides examples of the calculation of Ψ and χ values.

10 Determination of thermal coupling coefficient, heat flow rate and linear thermal transmittance from 2-D calculations

10.1 Two boundary temperatures

The heat flow rate per metre length, Φ_l , of the linear thermal bridge from the internal environment, designated by the subscript "i", to the external environment, designated by the subscript "e", is given by

$$\Phi_l = L_{2D}(\theta_i - \theta_e) \quad (15)$$

where L_{2D} is the thermal coupling coefficient obtained from a 2-D calculation of the component separating the two environments being considered.

10.2 More than two boundary temperatures

The heat flow rate, $\Phi_{i,j}$, from environment i to a thermally connected environment j is given by

$$\Phi_{i,j} = L_{2D,i,j}(\theta_i - \theta_j) \quad (16)$$

For more than two environments with different temperatures (e.g. different internal temperatures or different external temperatures), the total heat flow rate Φ to/from the room or the building can be calculated from

$$\Phi = \sum_{i < j} [L_{2D,i,j}(\theta_i - \theta_j)] \quad (17)$$

where $L_{2D,i,j}$ are the coupling coefficients between each pair of environments.

10.3 Determination of the linear thermal transmittance

The linear thermal transmittance considered of the linear thermal bridge separating the two environments being, Ψ , is given by

$$\Psi = L_{2D} - \sum_{j=1}^{N_j} U_j l_j \quad (18)$$

where

U_j is the thermal transmittance of the 1-D component j separating the two environments being considered;

l_j is the length within the 2-D geometrical model over which the value U_j applies;

N_j is the number of 1-D components.

When determining the linear thermal transmittance, it is necessary to state which dimensions (e.g. internal or external) are being used, because for several types of thermal bridges, the value of the linear thermal transmittance depends on this choice.

10.4 Determination of the linear thermal transmittance for wall/floor junctions

10.4.1 Numerical calculations using a two-dimensional geometrical model can be used to determine values of linear thermal transmittance for wall/floor junctions.

Model the full detail, including half the floor width or 4 m (whichever is the smaller), and a section of the wall to height h_W , and calculate L_{2D} as the heat flow rate per temperature difference and per perimeter length. h_W shall be the minimum distance from the junction to a cut-off plane in accordance with the criteria in 5.2.3 and h_f shall be the height of the top of the floor slab above ground level (see Figure 15). The dimensions of the model outside the building and below ground extend to 2,5 times the floor width or 20 m (whichever is the smaller). See also 5.2.4.

If the calculation is done using a 4 m floor width (i.e. $B' = 8$ m), the result can be used for any floor of greater size ($B' > 8$ m).

10.4.2 Option A Then calculate the thermal transmittance of the floor, U_g , using the simplified procedure in ISO 13370, using the same value for B' and including any all-over insulation of the floor slab. Calculate Ψ_g from Equation (19) using internal dimensions, and from Equation (20) using external dimensions:

$$\Psi_g = L_{2D} - h_W U_W - 0,5 \times B' U_g \tag{19}$$

$$\Psi_g = L_{2D} - (h_W + h_f) U_W - 0,5 \times (B' + w) U_g \tag{20}$$

where U_W is the thermal transmittance of the wall above ground, as modelled in the numerical calculation.

NOTE Option A is especially suitable if the simplified procedure in ISO 13370 will be used for calculating the heat transfer via the ground for any floor size.

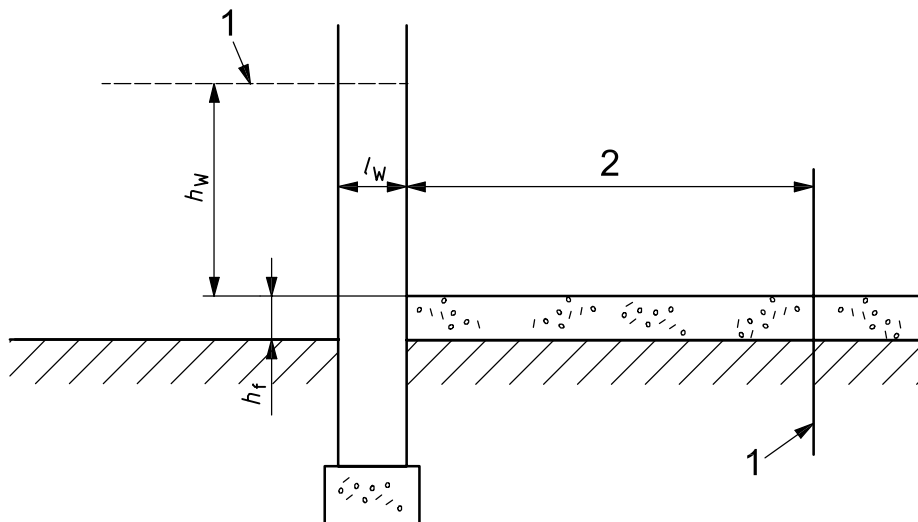

Key

- 1 adiabatic boundary
- 2 $0,5 \times B'$ or 4 m
- h_f height of the top of the floor slab above ground level
- h_W minimum distance from junction to cut-off plane (see 5.2.3)
- l_W fixed distance

NOTE The dimensions of the model extend to $2,5 \times B'$ or 20 m outside the building and below ground.

Figure 15 — Model for calculation of linear thermal transmittance of wall/floor junction

10.4.3 Option B Alternatively, replace all material below ground with soil (but retaining any all-over floor insulation) and remove the wall down to outside ground level (see Figure 16). Use adiabatic boundaries where the wall was previously in contact with the floor slab or the ground. Obtain $L_{2D,a}$ by a second numerical calculation on the revised detail.

Then

$$\Psi_g = L_{2D} - h_W U_W - L_{2D,a} \quad (21)$$

NOTE For an example of the treatment of suspended floors, see C.5.

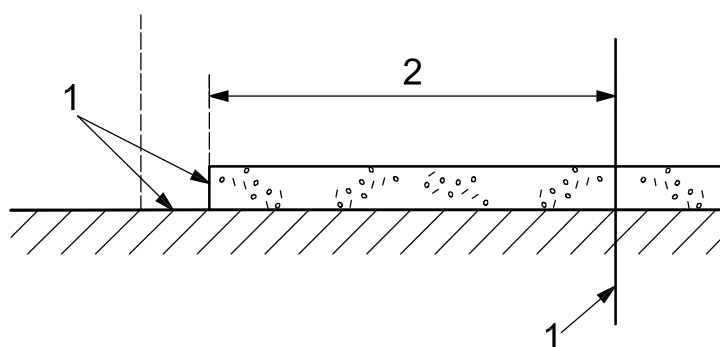

Key

- 1 adiabatic boundary
- 2 $0,5 \times B'$ or 4 m

Figure 16 — Model for second numerical calculation for Option B

10.5 Determination of the external periodic heat transfer coefficient for ground floors

The geometrical model of 10.4 can be used with a time-dependent numerical calculation method to determine both Ψ_g and the external periodic heat transfer coefficient, H_{pe} . The size of the time-steps should be such as to ensure a stable calculation. Determine the mean total heat flow through the internal surfaces in W/m for each month of the year. The calculation is continued until the heat flow through the internal surfaces for the month of December of the last year differs by less than 1 % from the heat flow in December for the previous year. This can normally be obtained by calculating at least 10 years.

The internal temperature is kept at a constant value, $\bar{\theta}_i$, and the external temperature, at time t , in °C, $\theta_e(t)$, is represented by

$$\theta_e(t) = \bar{\theta}_e - \hat{\theta}_e \cos\left(2\pi \frac{t - \tau}{12}\right) \quad (22)$$

where

- $\bar{\theta}_e$ is the annual average external temperature, in °C;
- $\hat{\theta}_e$ is the amplitude of variations in monthly mean external temperature, in K;
- t is the time, expressed in months ($t = 0$ at the beginning of January);
- τ is the time, expressed in months, at which the minimum external temperature occurs.

For further information, including properties of the ground, see ISO 13370.

For each month, obtain the heat flow, q_m , additional to that accounted for by U_W and U_g :

$$q_m = q_{c,m} - h_W U_W (\bar{\theta}_i - \theta_{e,m}) - 0,5 B' U_g (\bar{\theta}_i - \bar{\theta}_e) \quad (23)$$

where $q_{c,m}$ is the mean heat flow through the internal surfaces in month m , as obtained from the numerical results. Then

$$\Psi_g = \frac{\sum_{m=1}^{12} q_m}{12(\bar{\theta}_i - \bar{\theta}_e)} \quad (24)$$

and

$$H_{pe} = P \frac{q_{\max} - q_{\min}}{2\hat{\theta}_e} \quad (25)$$

where

P is the exposed perimeter of the floor;

q_{\max} is the maximum value of q_m ;

q_{\min} is the minimum value of q_m .

NOTE H_{pe} calculated using Equation (25) includes Ψ_g .

11 Determination of the temperature at the internal surface

11.1 Determination of the temperature at the internal surface from 3-D calculations

11.1.1 Two boundary temperatures

If there are only two environments involved and the subsoil is not a part of the geometrical model, the surface temperatures can be expressed in a dimensionless form in accordance with Equation (26):

$$f_{Rsi}(x,y,z) = \frac{\theta_{si}(x,y,z) - \theta_e}{(\theta_i - \theta_e)} \quad (26)$$

where

$f_{Rsi}(x,y,z)$ is the temperature factor at the internal surface at point (x,y,z) ;

$\theta_{si}(x,y,z)$ is the temperature at the internal surface at point (x,y,z) ;

θ_i is the internal temperature;

θ_e is the external temperature.

The temperature factor shall be calculated with an error of less than 0,005.

11.1.2 More than two boundary temperatures

If there are more than two boundary temperatures, the temperature weighting factor, g , shall be used. The temperature weighting factors provide the means to calculate the temperature at any location at the inner surface with coordinates (x,y,z) as a linear function of any set of boundary temperatures.

NOTE 1 At least three boundary temperatures are involved if the geometrical model includes internal environments with different temperatures.

Using the temperature weighting factors, the surface temperature at location (x,y,z) in environment j is given by

$$\theta_j(x,y,z) = g_{j,1}(x,y,z) \theta_1 + g_{j,2}(x,y,z) \theta_2 + \dots + g_{j,n}(x,y,z) \theta_n \quad (27)$$

with

$$g_{j,1}(x,y,z) + g_{j,2}(x,y,z) + \dots + g_{j,n}(x,y,z) = 1 \quad (28)$$

NOTE 2 C.3 provides a method for calculating the weighting factors.

Calculate the internal surface temperature, θ_{si} , at the location of interest by inserting the calculated values of $g_{j,i}$ and the actual boundary temperatures, θ_i , in Equation (27).

NOTE 3 The location of interest is normally the point with the lowest internal surface temperature. This location can vary if the boundary temperatures are changed.

11.2 Determination of the temperature at the internal surface from 2-D calculations

11.2.1 Two boundary temperatures

When there are only two environments involved, the surface temperatures can be expressed in a dimensionless form in accordance with Equation (29):

$$f_{Rsi}(x,y) = \frac{\theta_{si}(x,y) - \theta_e}{\theta_i - \theta_e} \quad (29)$$

where

$f_{Rsi}(x,y)$ is the temperature factor for the internal surface at point (x,y) ;

$\theta_{si}(x,y)$ is the temperature for the internal surface at point (x,y) ;

θ_i is the internal temperature;

θ_e is the external temperature.

The temperature factor shall be calculated with an error of less than 0,005.

11.2.2 Three boundary temperatures

If there are three boundary temperatures involved, temperature weighting factors, g , shall be used. Temperature weighting factors provide the means to calculate the temperature at any location of the internal surface with coordinates (x,y) as a linear function of any set of boundary temperatures.

The surface temperatures at the location (x,y) in environment j are given by

$$\theta_j(x,y) = g_{j,1}(x,y) \theta_1 + g_{j,2}(x,y) \theta_2 + g_{j,3}(x,y) \theta_3 \quad (30)$$

with

$$g_{j,1}(x,y) + g_{j,2}(x,y) + g_{j,3}(x,y) = 1 \quad (31)$$

NOTE The weighting factors at the location of interest can be calculated in accordance with Annex C. The location of interest is normally the point with the lowest internal surface temperature. This location can vary if the boundary temperatures are changed.

Calculate the internal surface temperature, θ_{si} , at the location of interest by inserting the calculated values of $g_{j,1}$, $g_{j,2}$ and $g_{j,3}$ and the actual boundary temperatures, θ_1 , θ_2 and θ_3 , in Equation (30).

12 Input and output data

12.1 Input data

The report of the calculation shall contain the following information:

- a) description of structure:
 - building plans including dimensions and materials;
 - for a completed building, any known alterations to the construction and/or physical measurements and details from inspection;
 - other relevant remarks;
- b) description of the geometrical model:
 - 2-D or 3-D geometrical model with dimensions;
 - input data showing the location of the construction planes and any auxiliary planes, together with the thermal conductivities of the various materials;
 - the applied boundary temperatures;
 - a calculation of the boundary temperature in an adjacent area, when appropriate;
 - the surface resistances and the areas to which they apply;
 - any dimensional adjustments in accordance with 5.3.2;
 - any quasi-homogeneous layers and the thermal conductivities calculated in accordance with 5.3.3;
 - any non-standard values used with justification of the deviation from standard values (see 6.1).

12.2 Output data

12.2.1 General

The following calculation results shall be reported as values that are independent of the boundary temperatures:

- thermal coupling coefficient L_{3D} or L_{2D} between adjacent rooms involved in heat transfer through the building components;

NOTE 1 An example is given in Table C.2.

- if appropriate, the linear thermal transmittance, Ψ , of the linear thermal bridge, stating whether internal or external dimensions were used;
- temperature factor, f_{Rsi} , for the points of lowest surface temperatures in each room involved (including the location of these points); if more than two boundary temperatures are used, the temperature weighting factors shall be reported.

NOTE 2 An example of how to report temperature weighting factors is given in Table C.4.

All output values shall be given to at least three significant figures.

12.2.2 Calculation of the heat transmission using the thermal coupling coefficient

The heat transmission from environment i to environment j is given by Equation (10) if there are more than two boundary temperatures, by Equation (9) if there are two boundary temperatures, or by Equation (15) for a 2-D geometrical model.

12.2.3 Calculation of the surface temperatures using weighting factors

The lowest internal surface temperature exposed to room j is given by Equation (27) for a 3-D geometrical model or by Equation (30) for a 2-D geometrical model.

12.2.4 Additional output data

For a specific set of boundary temperatures, the following additional values shall be presented:

- heat flow rates, in watts per metre (for 2-D cases) or in watts (for 3-D cases), for each pair of rooms of interest;
- minimum surface temperatures, in degrees Celsius, and the location of the points with minimum surface temperature in each room of interest.

12.2.5 Estimate of error

Numerical procedures give approximate solutions which converge to analytical solutions, if one exists. In order to evaluate the reliability of the results, the residual error should be estimated, as described below.

- In order to estimate errors due to insufficient numbers of cells, additional calculation(s) shall be made in accordance with A.2. The difference in results for both calculations shall be stated.
- In order to estimate errors arising in the numerical solution of the equation system, the sum of heat flows (positive and negative) over all boundaries of the building component divided by the total heat flow shall be given.

NOTE A.2 specifies that this quotient is to be less than 0,000 1.

Annex A (normative)

Validation of calculation methods

A.1 Test reference cases

A.1.1 General

In order to be classified as a three-dimensional steady-state high precision method, a calculation method shall give results corresponding to those of the test reference cases 1, 2, 3, and 4, represented respectively in Figures A.1, A.2, A.3 and A.4.

In order to be classified as a two-dimensional steady-state high precision method, it shall give results corresponding to those of the test reference cases 1 and 2, represented respectively in Figures A.1 and A.2.

A.1.2 Case 1

The heat transfer through half a square column, with known surface temperatures, can be calculated analytically, as shown in Figure A.1. The analytical solution at 28 points of an equidistant grid is given in the same figure. The difference between the temperatures calculated by the method being validated and the temperatures listed shall not exceed 0,1 °C.

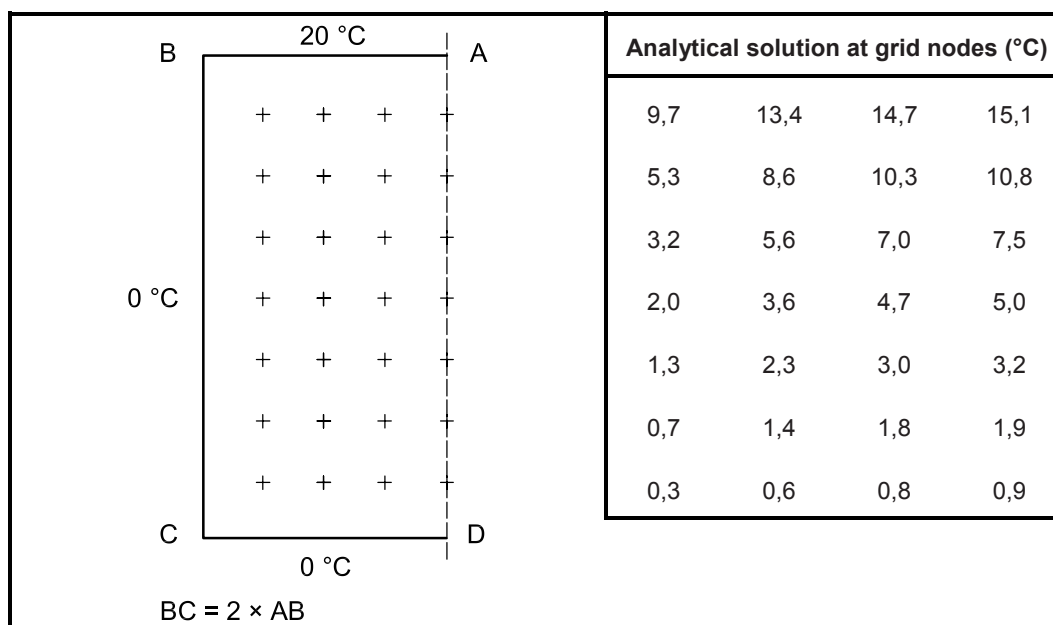
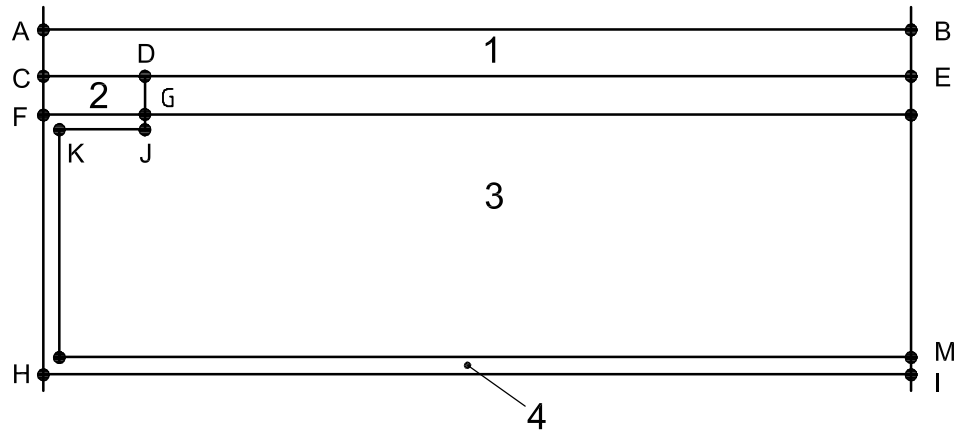

Figure A.1 — Test reference case 1: comparison with the analytical solution

A.1.3 Case 2

A.1.3.1 Description of model for case 2

An example of two-dimensional heat transfer is given in Figure A.2 and Tables A.1 and A.2.



Key

- 1 concrete
- 2 wood
- 3 insulation
- 4 aluminium

Figure A.2 — Test reference case 2: two-dimensional heat transfer

Table A.1 — Description of model for case 2

Dimensions mm	Thermal conductivity W/(m·K)	Boundary conditions
AB = 500	1: 1,15	AB: 0 °C with $R_{se} = 0,06 \text{ m}^2\cdot\text{K/W}$
AC = 6	2: 0,12	HI: 20 °C with $R_{si} = 0,11 \text{ m}^2\cdot\text{K/W}$
CD = 15	3: 0,029	
CF = 5	4: 230	
EM = 40		
GJ = 1,5		
IM = 1,5		
FG – KJ = 1,5		

A.1.3.2 Numerical solution for case 2

Table A.2 — Temperature results for case 2

Temperatures °C		
A: 7,1		B: 0,8
C: 7,9	D: 6,3	E: 0,8
F: 16,4	G: 16,3	
H: 16,8		I: 18,3
Total heat flow rate: 9,5 W/m		

The difference between the temperatures calculated by the method being validated and the temperatures listed shall not exceed 0,1 °C. The difference between the heat flow calculated by the method being validated and the heat flow listed shall not exceed 0,1 W/m.

A.1.4 Case 3

A.1.4.1 Description of model for case 3

An example of three-dimensional heat transfer is given in Figure A.3 and Tables A.3, A.4 and A.5.

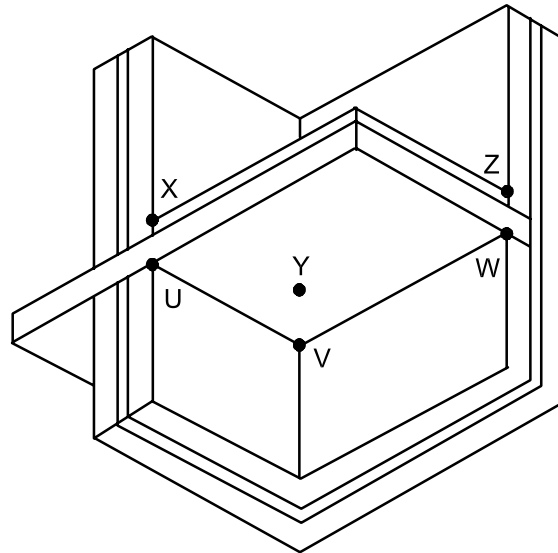

NOTE Y and V are three-dimensional corners.

a) Perspective view

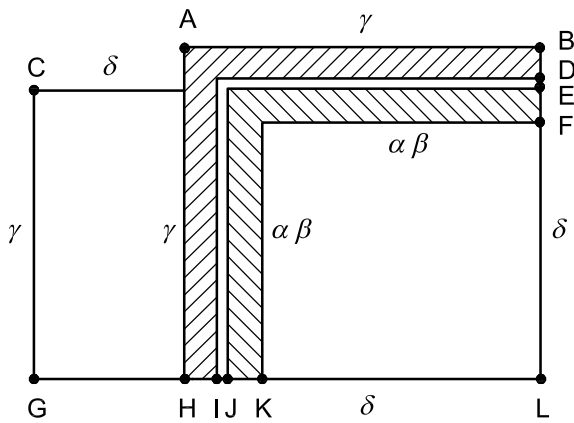

b) Horizontal section

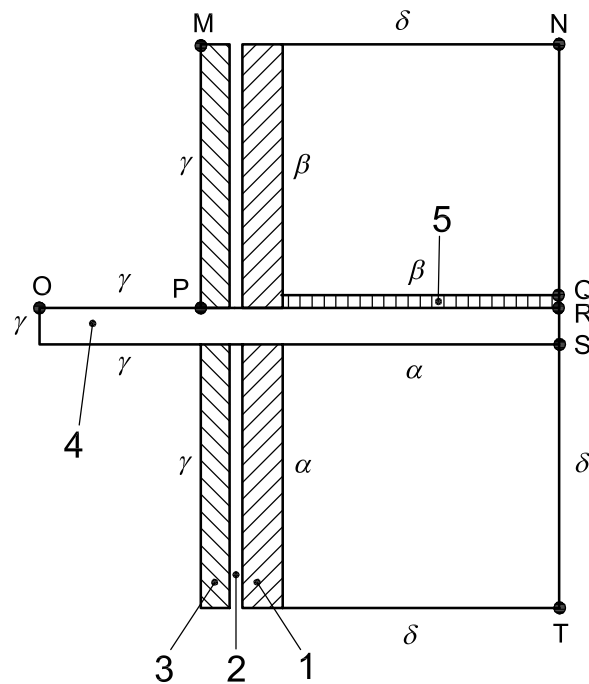

c) Vertical section

Figure A.3 — Test reference case 3: three-dimensional geometrical model

Table A.3 — Description of the model for case 3

Dimensions mm	Thermal conductivity W/(m·K)	Boundary conditions
AB = 1300	1: 0,7	α : 20 °C with $R_{si} = 0,20 \text{ m}^2\cdot\text{K/W}$
BD = HI = 100	2: 0,04	β : 15 °C with $R_{si} = 0,20 \text{ m}^2\cdot\text{K/W}$
DE = IJ = 50	3: 1,0	γ : 0 °C with $R_{se} = 0,05 \text{ m}^2\cdot\text{K/W}$
EF = JK = 150	4: 2,5	δ : adiabatic
FL = KL = 1 000	5: 1,0	
CG = 1150		
GH = 600		
MP = ST = 1 000		
QR = 50		
RS = 150		
NQ = 950		
OP = 600		

A.1.4.2 Numerical solution for case 3: surface temperature factors

Table A.4 — Temperature results for case 3

Environment	Temperature factors		
	g_γ	g_α	g_β
γ	1,000	0,000	0,000
α	0,378	0,399	0,223
β	0,331	0,214	0,455

The lowest surface temperatures in the environments α and β are in the corners of both indoor environments:

$$\theta_{\min} = g_\gamma \cdot \theta_\gamma + g_\alpha \cdot \theta_\alpha + g_\beta \cdot \theta_\beta \quad (\text{A.1})$$

$$\theta_{\alpha,\min} = 0,378 \times 0 + 0,223 \times 15 + 0,399 \times 20 = 11,32 \text{ °C} \quad (\text{A.2})$$

$$\theta_{\beta,\min} = 0,331 \times 0 + 0,455 \times 15 + 0,214 \times 20 = 11,11 \text{ °C} \quad (\text{A.3})$$

The difference between the lowest internal surface temperature of both environments calculated by the method being validated and the temperature listed shall not exceed 0,1 °C.

A.1.4.3 Numerical solution for case 3: heat flows

Table A.5 — Thermal coupling coefficients for case 3

Environment	Thermal coupling coefficients W/K		
	γ	α	β
γ	—	1,781	1,624
α	1,781	—	2,094
β	1,624	2,094	—

The heat flow between pairs of environments is calculated as follows:

— for β and γ :

$$\Phi_{\beta,\gamma} = L_{\beta,\gamma} \Delta\theta_{\beta,\gamma} = 1,624 \times (15 - 0) = 24,36 \text{ W} \quad (\text{A.4})$$

— for β and α :

$$\Phi_{\beta,\alpha} = L_{\beta,\alpha} \Delta\theta_{\beta,\alpha} = 2,094 \times (20 - 15) = 10,47 \text{ W} \quad (\text{A.5})$$

— for α and γ :

$$\Phi_{\alpha,\gamma} = L_{\alpha,\gamma} \Delta\theta_{\alpha,\gamma} = 1,781 \times (20 - 0) = 35,62 \text{ W} \quad (\text{A.6})$$

The heat flow from internal to external environment is calculated as follows:

$$\Phi_{\beta,\gamma} + \Phi_{\alpha,\gamma} = 24,36 + 35,62 = 58,98 \text{ W} \quad (\text{A.7})$$

The heat flow balance for the environments β and α is calculated as follows:

$$\Phi_{\beta,\gamma} + \Phi_{\beta,\alpha} = 24,36 + 10,47 = 34,83 \text{ W} \quad (\text{A.8})$$

$$\Phi_{\alpha,\gamma} + \Phi_{\alpha,\beta} = 35,62 - 10,47 = 25,15 \text{ W} \quad (\text{A.9})$$

The difference between the heat flows calculated by the method being validated and the heat flows listed shall not exceed 1 %.

A.1.5 Case 4

Case 4 is a three-dimensional thermal bridge consisting of an iron bar penetrating an insulation layer, as shown in Figure A.4 and Tables A.6 and A.7.

The difference between the lowest internal surface temperatures calculated by the method being validated and the temperature listed shall not exceed 0,005 °C. The difference between the heat flow calculated by the method being validated and the heat flow listed, shall not exceed 1 %.

Table A.6 — Description of model for case 4

Dimensions mm	Thermal conductivity W/(m·K)	Boundary conditions
Insulation: 1 000 × 1 000 × 200	Insulation: 0,1 W/(m·K)	Internal: 1 °C with $R_{si} = 0,10 \text{ m}^2 \cdot \text{K/W}$
Iron bar: 600 × 100 × 50	Iron bar: 50 W/(m·K)	External: 0 °C with $R_{se} = 0,10 \text{ m}^2 \cdot \text{K/W}$
		Cut-off planes: adiabatic

Table A.7 — Numerical solution for case 4

Heat flow	0,540 W
Highest surface temperature on the external side	0,805 °C

Dimensions in millimetres

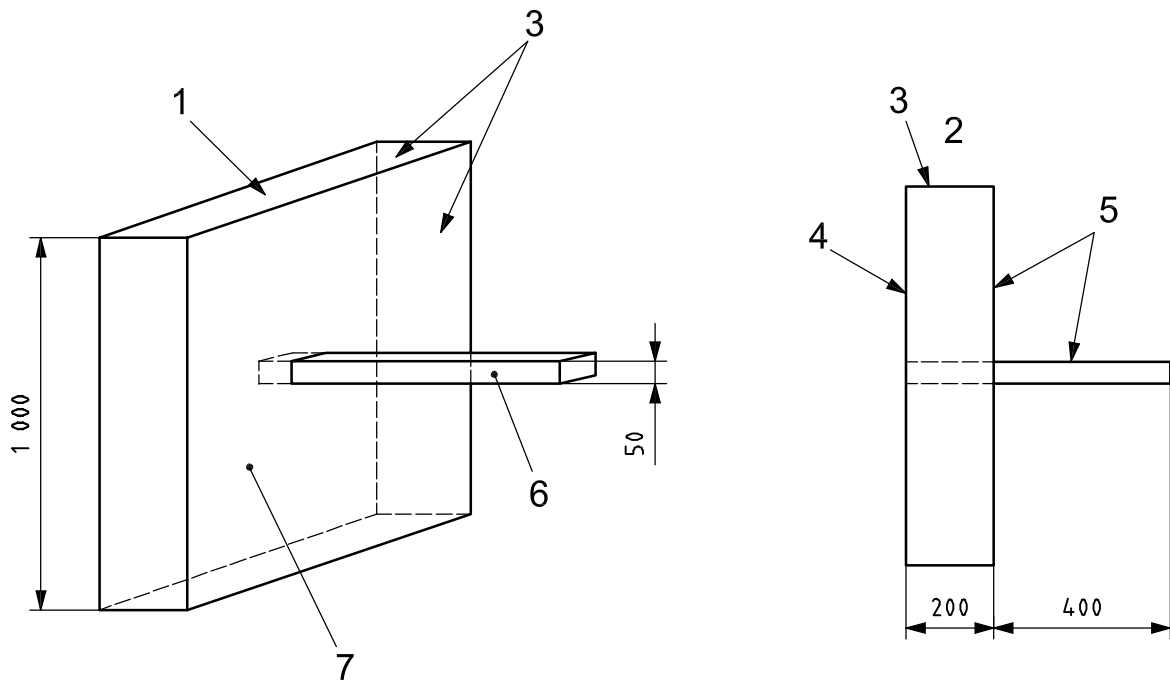

Key

- 1 top
- 2 top view
- 3 adiabatic cut-off planes
- 4 external surface
- 5 internal surface
- 6 iron bar
- 7 insulation

Figure A.4 — Test reference case 4: iron bar penetrating an insulation layer

A.2 General considerations and requirements for validation of calculation methods

High precision calculation methods are known as numerical methods (e.g. finite element method, finite difference method, heat balance method). These numerical methods require a subdivision of the object considered. The method is a set of rules to form a system of equations, the number of which is proportional to the number of subdivisions. The system is solved using either a direct solution method or an iterative method. The solution of the system is normally the temperatures at specific points, from which the temperatures at any point of the object considered can be derived (by interpolation); the heat flows through specific surfaces can also be derived.

The numerical method being validated shall meet the requirements listed below.

- a) The method shall provide temperatures and heat flows.
- b) The extent of subdivision of the object (i.e. the number of cells, nodes) is not “method defined” but “user defined”, although in practice the degree of subdivision is “machine limited”. Therefore, in the test reference cases, the method being validated shall be able to calculate temperatures and heat flows at locations other than those listed.
- c) For an increasing number of subdivisions, the solution of the method being validated shall converge to the analytical solution, if such a solution exists (e.g. test reference case 1).

NOTE For an increasing number of subdivisions, the solution converges. The number of subdivisions required to obtain good accuracy depends on the problem considered and on the solution technique. The error is expected to take the form $\alpha/N^{\beta/3}$ where α and β are constants for a given problem and N is the total number of nodes in the model.

- d) The number of subdivisions shall be determined as follows: the sum of the absolute values of all the heat flows entering the object is calculated twice, for n nodes (or cells) and for $2n$ nodes (or cells). The difference between these two results shall not exceed 1 %. If not, further subdivisions shall be made until this criterion is met.
- e) If the system solution technique is iterative, the iteration shall continue until the sum of all heat flows (positive and negative) entering the object, divided by half the sum of the absolute values of all these heat flows, is less than 0,000 1.

Annex B (informative)

Examples of the determination of the linear and point thermal transmittances

B.1 General

This annex shows two typical arrangements of building components:

- Case 1 with two separate environments;
- Case 2 with three separate environments.

For each case, the specific equations to be used in determining Ψ and χ values are given.

Figures B.1 and B.2 illustrate the lengths for internal dimensions. If external dimensions are being used, the same formulae apply with the lengths measured to the external surfaces of the components.

B.2 Case 1

A 3-D building component separating two environments, R_1 and R_0 . The equations in Figure B.1 are used to determine Ψ and χ values.

B.3 Case 2

A 3-D building component separating three environments. Consider the two environments, R_1 and R_0 . The equations in Figure B.2 are used to determine Ψ and χ values.

Dimensions in millimetres

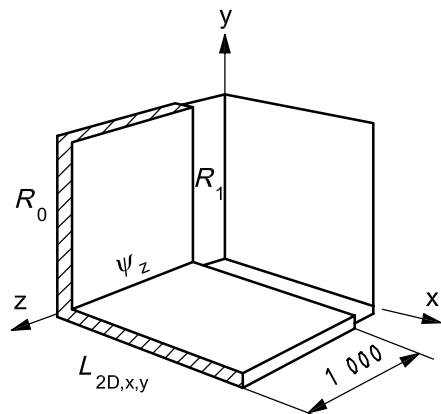
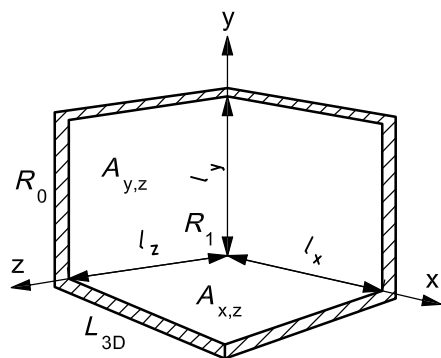

$$\Psi_z = L_{2D,x,y} - U_{x,z} l_x - U_{y,z} l_y$$

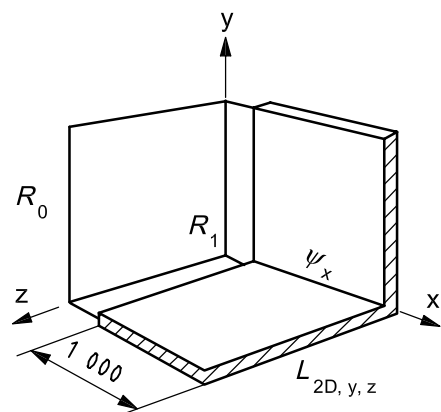

$$\Psi_x = L_{2D,y,z} - U_{x,y} l_y - U_{x,z} l_z$$

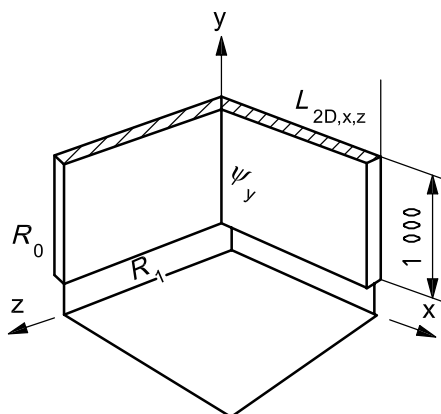

$$\Psi_y = L_{2D,x,z} - U_{x,y} l_y - U_{y,z} l_z$$

$$\chi = L_{3D} - L_{2D,x,y} l_z - L_{2D,y,z} l_x - L_{2D,x,z} l_y + U_{x,y} A_{x,y} + U_{x,z} A_{x,z} + U_{y,z} A_{y,z}$$

NOTE For explanations of symbols, see 3.2.

Figure B.1 — Case 1: 3-D building component separating two environments

Dimensions in millimetres

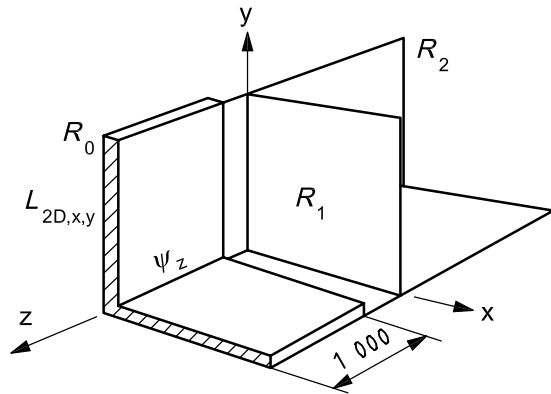
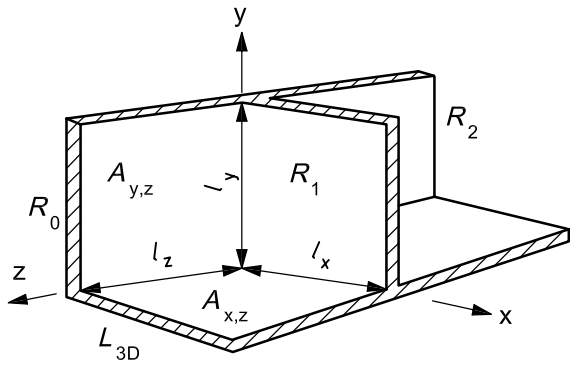

$$\Psi_z = L_{2D,x,y} - U_{x,z} l_x - U_{y,z} l_y$$

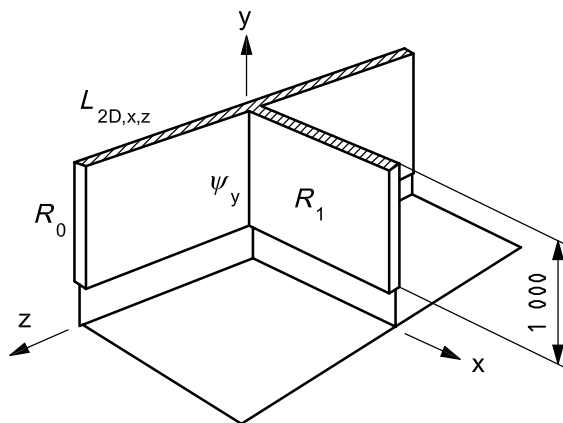

$$\Psi_y = L_{2D,x,z} - U_{y,z} l_z$$

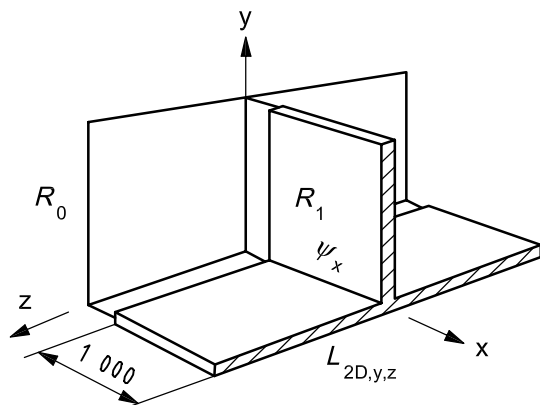

$$\Psi_x = L_{2D,y,z} - U_{x,z} l_z$$

$$\chi = L_{3D} - L_{2D,x,y} l_z - L_{2D,y,z} l_x - L_{2D,x,z} l_y + U_{y,z} A_{y,z} + U_{x,z} A_{x,z} + U_{x,y} A_{x,y}$$

NOTE For explanations of symbols, see 3.2.

Figure B.2 — Case 2: 3-D building component separating three environments

Annex C (informative)

Determination of values of thermal coupling coefficient and temperature weighting factor for more than two boundary temperatures

C.1 Determination of the thermal coupling coefficients, L

For a model with n boundary temperatures, there are up to $n(n-1)/2$ separate coupling coefficients. The coefficients are derived through undertaking calculations by assigning boundary temperatures to each environment as shown in Table C.1. The total number of calculations needed is equal to the number of environments directly connected to each other, which in practice can be less than $n(n-1)/2$. The result of each calculation is a sum of L values, giving a system of simultaneous equations which are then solved to obtain the individual thermal coupling coefficients.

NOTE Temperature differences of 1 K are shown in Table C.1 to illustrate the calculation scheme. Any suitable non-zero value can be used for the actual calculation. It is advisable that temperature-dependent properties be evaluated with regard to the expected internal and external temperatures in practice.

Table C.1 — Scheme for calculating L values in the case of n boundary temperatures

Calculation number	Boundary temperatures, °C				Result of calculation
	θ_1	θ_2	θ_i	θ_n	
1	1	0	0	0	$\sum_{k \neq 1} L_{1,k}$
2	0	1	0	0	$\sum_{k \neq 2} L_{2,k}$
i	0	0	1	0	$\sum_{k \neq i} L_{i,k}$
n	0	0	0	1	$\sum_{k \neq n} L_{n,k}$
$n + 1$	1	1	0	0	$\sum_{k \neq 1,2} L_{1,k} + \sum_{k \neq 1,2} L_{2,k}$
$n + 2$	1	0	1	0	$\sum_{k \neq 1,i} L_{1,k} + \sum_{k \neq 1,i} L_{i,k}$

C.2 Report of the thermal coupling coefficients, L

In the case of thermal bridges, only the thermal coupling coefficients, $L_{i,j}$, for each pair of environments thermally connected to the building component under consideration are of interest. This reduces the number of environments involved.

The thermal coupling coefficients, $L_{i,j}$, should be given in the form of Table C.2. For any two environments that are not thermally connected to each other, L should be reported as 0.

NOTE 1 More than three environments are unusual.

Table C.2 — Presentation scheme of L values for n boundary temperatures

Environment number	1	2	i	n
1	—	$L_{1,2}$	$L_{1,i}$	$L_{1,n}$
2	$L_{2,1}$	—	$L_{2,i}$	$L_{2,n}$
i	$L_{i,1}$	$L_{i,2}$	—	$L_{i,n}$
n	$L_{n,1}$	$L_{n,2}$	$L_{n,i}$	—

NOTE 2 The scheme is symmetric, with $L_{i,j} = L_{j,i}$.

The set of R_{s_i} values used in the calculation of the L values should be reported, together with a sketch that shows to which inner surface area each R_{s_i} value applies.

C.3 Determination of the temperature weighting factors, g

For a model with n boundary temperatures, the weighting factors can be calculated by repeating $(n-1)$ times the calculation of the temperature at the selected point; in each successive calculation, every boundary temperature is taken as 0 °C except one boundary temperature, which is taken as 1 °C, as shown in Table C.3.

Table C.3 — Scheme for calculating g values in the case of n boundary temperatures

Calculation number	Boundary temperatures, °C				Weighting factors
	θ_1	θ_2	θ_i	θ_n	
1	1	0	0	0	g_1
2	0	1	0	0	g_2
i	0	0	1	0	g_i
$n-1$	0	0	0	1	g_{n-1}

After $(n-1)$ calculations g_n follows from Equation (28).

C.4 Report of the temperature weighting factors, g

The temperature weighting factors of the points of lowest temperature for a building component with n environments involved should be given in accordance with Table C.4.

Table C.4 — Presentation scheme of g values for n boundary temperatures

Environment number	1	2	i	n
1	$g_{1,1}$	$g_{1,2}$	$g_{1,i}$	$g_{1,n}$
2	$g_{2,1}$	$g_{2,2}$	$g_{2,i}$	$g_{2,n}$
i	$g_{i,1}$	$g_{i,2}$	$g_{i,i}$	$g_{i,n}$
n	$g_{n,1}$	$g_{n,2}$	$g_{n,i}$	$g_{n,n}$

NOTE In the case of three thermally different environments, the minimum surface temperature in two rooms is normally of interest. This means that the scheme of Table C.3 is applied twice, with a total of four calculations in order to derive the values for Table C.4.

The set of R_{si} values used in the calculation of the g values should be reported together with a sketch that shows to which internal surface area each R_{si} value applies.

C.5 Example

C.5.1 Calculation of the geometrical model

The example illustrates a 2-D calculation for a suspended floor. There are three boundary temperatures: the internal environment, θ_i , the external environment, θ_e , and the underfloor space, θ_u (see Figure C.1).

The temperature in the underfloor space depends on the internal and external temperatures, and also on the thermal properties of the construction. Because of the latter, it is not known *a priori*.

The thermal coupling coefficients are:

- L_{ie} : thermal coupling coefficient between internal and external environments;
- L_{iu} : thermal coupling coefficient between internal environment and underfloor space;
- L_{ue} : thermal coupling coefficient between underfloor space and external environment.

NOTE 1 L_{ue} includes heat flow through the ground. For soil dimensions, see 5.2.4.

The underfloor space is ventilated from outside. If the ventilation is not included in the numerical model, L_{ue} is divided into two components:

$$L_{ue} = L_{ue,c} + L_{ue,v} \quad (\text{C.1})$$

where

$L_{ue,c}$ is the thermal coupling coefficient for heat conduction through the walls of the underfloor space and through the ground;

$L_{ue,v}$ represents the heat transfer attributable to exchange of air between the underfloor and the external environment.

NOTE 2 Any unventilated airspaces are included within the numerical model (using an equivalent thermal conductivity).

The separate thermal coupling coefficients are obtained following the scheme in C.1. The same geometrical model is calculated three times with different boundary conditions, as shown in Table C.5. Φ is the total heat flow. There are two possibilities, as described below.

- a) Modelling calculations do not allow for air exchange. The software is run for heat conduction only, and the ventilation is allowed for separately.
- b) Modelling calculations do allow for air exchange. The software is run inclusive of the ventilation of the underfloor space, set at a rate appropriate to the ventilation arrangements (see ISO 13370:2007, Annex E). In this case, there is no need to consider the transmission and ventilation components of L_{ue} separately.

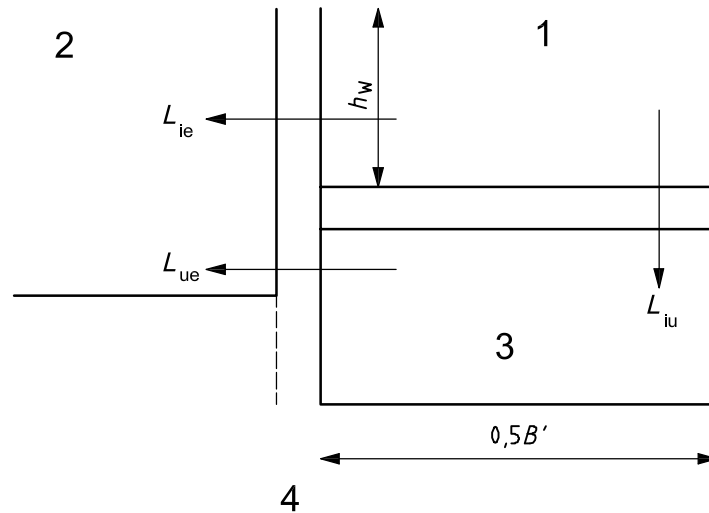

Key

- 1 internal environment, θ_i
- 2 external environment, θ_e
- 3 underfloor space, θ_u
- 4 ground
- B' characteristic dimension of floor
- h_W minimum distance from junction to cut-off plane
- L_{ie} thermal coupling coefficient between internal and external environments
- L_{iu} thermal coupling coefficient between internal environment and underfloor space
- L_{ue} thermal coupling coefficient between underfloor space and external environment

Figure C.1 — Schematic of suspended floor

Table C.5 — Modelling conditions

Calculation number	θ_i °C	θ_e °C	θ_u °C	Result of calculation	
				if modelling calculations do not take account of air exchange	if modelling calculations do take account of air exchange
1	1	0	0	$L_1 = L_{ie} + L_{iu}$	$L_1 = L_{ie} + L_{iu}$
2	0	1	0	$L_2 = L_{ie} + L_{ue,c}$	$L_2 = L_{ie} + L_{ue}$
3	0	0	1	$L_3 = L_{iu} + L_{ue,c}$	$L_3 = L_{iu} + L_{ue}$

From the results of the modelling calculations, the thermal coupling coefficients of interest are obtained by solving the simultaneous equations, leading to:

$$L_{iu} = 0,5 \times (L_1 - L_2 + L_3) \tag{C.2}$$

$$L_{ie} = 0,5 \times (L_1 + L_2 - L_3) \tag{C.3}$$

$$L_{ue,c} = 0,5 \times (L_2 + L_3 - L_1) \text{ [if modelling does not include air exchange]} \tag{C.4}$$

$$L_{ue} = 0,5 \times (L_2 + L_3 - L_1) \text{ [if modelling does include air exchange]} \tag{C.5}$$

C.5.2 Ventilation air exchange not included in the model

If ventilation air exchange between the underfloor space and the outside is not included in the model, the ventilation term $L_{ue,v}$ is calculated using Equation (C.6):

$$L_{ue,v} = \rho c_p \dot{V} \quad (C.6)$$

where

ρ is the density of air;

c_p is the specific heat of air at constant pressure;

\dot{V} is the volumetric flow rate per perimeter length (see ISO 13370:2007, Annex E).

L_{ue} is then obtained using Equation (C.1).

The total heat flow inside to outside is

$$\Phi = L_{iu}(\theta_i - \theta_u) + L_{ie}(\theta_i - \theta_e) \quad (C.7)$$

leading to

$$\Phi = \left(\frac{L_{iu} L_{ue}}{L_{iu} + L_{ue}} + L_{ie} \right) (\theta_i - \theta_e) \quad (C.8)$$

In general

$$\Phi = L_{2D}(\theta_i - \theta_e) \quad (C.9)$$

where L_{2D} is the thermal coupling coefficient from inside to outside, so that

$$L_{2D} = \left(\frac{L_{iu} L_{ue}}{L_{iu} + L_{ue}} + L_{ie} \right) \quad (C.10)$$

The linear thermal transmittance for the wall/floor junction is obtained in accordance with 10.4:

$$\Psi_g = L_{2D} - h_w U_w - 0,5 \times B' U \quad (C.11)$$

C.5.3 Ventilation air exchange included in model

In this case, θ_u is not assigned. The numerical calculation is run once with boundary temperatures θ_i and θ_e giving L_{2D} , and Ψ_g is obtained from Equation (C.11).

NOTE This can give a slightly different result, as the underfloor space is modelled as a solid with equivalent thermal conductivity instead of a single node.

Bibliography

- [1] ISO 10077-2, *Thermal performance of windows, doors and shutters — Calculation of thermal transmittance — Part 2: Numerical method for frames*
- [2] ISO 10456, *Building materials and products — Hygrothermal properties — Tabulated design values and procedures for determining declared and design thermal values*
- [3] ISO 13789, *Thermal performance of buildings — Transmission and ventilation heat transfer coefficients — Calculation method*
- [4] ISO 14683, *Thermal bridges in building construction — Linear thermal transmittance — Simplified methods and default values*
- [5] EN 673, *Glass in building — Determination of thermal transmittance (U value) — Calculation method*

BSI - British Standards Institution

BSI is the independent national body responsible for preparing British Standards. It presents the UK view on standards in Europe and at the international level. It is incorporated by Royal Charter.

Revisions

British Standards are updated by amendment or revision. Users of British Standards should make sure that they possess the latest amendments or editions.

It is the constant aim of BSI to improve the quality of our products and services. We would be grateful if anyone finding an inaccuracy or ambiguity while using this British Standard would inform the Secretary of the technical committee responsible, the identity of which can be found on the inside front cover. Tel: +44 (0)20 8996 9000. Fax: +44 (0)20 8996 7400.

BSI offers members an individual updating service called PLUS which ensures that subscribers automatically receive the latest editions of standards.

Buying standards

Orders for all BSI, international and foreign standards publications should be addressed to Customer Services. Tel: +44 (0)20 8996 9001. Fax: +44 (0)20 8996 7001 Email: orders@bsigroup.com You may also buy directly using a debit/credit card from the BSI Shop on the Website <http://www.bsigroup.com/shop>

In response to orders for international standards, it is BSI policy to supply the BSI implementation of those that have been published as British Standards, unless otherwise requested.

Information on standards

BSI provides a wide range of information on national, European and international standards through its Library and its Technical Help to Exporters Service. Various BSI electronic information services are also available which give details on all its products and services. Contact Information Centre. Tel: +44 (0)20 8996 7111 Fax: +44 (0)20 8996 7048 Email: info@bsigroup.com

Subscribing members of BSI are kept up to date with standards developments and receive substantial discounts on the purchase price of standards. For details of these and other benefits contact Membership Administration. Tel: +44 (0)20 8996 7002 Fax: +44 (0)20 8996 7001 Email: membership@bsigroup.com

Information regarding online access to British Standards via British Standards Online can be found at <http://www.bsigroup.com/BSOL>

Further information about BSI is available on the BSI website at <http://www.bsigroup.com>.

Copyright

Copyright subsists in all BSI publications. BSI also holds the copyright, in the UK, of the publications of the international standardization bodies. Except as permitted under the Copyright, Designs and Patents Act 1988 no extract may be reproduced, stored in a retrieval system or transmitted in any form or by any means – electronic, photocopying, recording or otherwise – without prior written permission from BSI.

This does not preclude the free use, in the course of implementing the standard, of necessary details such as symbols, and size, type or grade designations. If these details are to be used for any other purpose than implementation then the prior written permission of BSI must be obtained.

Details and advice can be obtained from the Copyright and Licensing Manager. Tel: +44 (0)20 8996 7070 Email: copyright@bsigroup.com