



BSI Standards Publication

**Pipes and fittings made of  
crosslinked polyethylene  
(PE-X) — Estimation of the  
degree of crosslinking by  
determination of the gel  
content**

### National foreword

This British Standard is the UK implementation of EN ISO 10147:2012. It is identical to ISO 10147:2011. It supersedes BS EN 579:1994 and BS ISO 10147:2011, which are withdrawn.

The UK participation in its preparation was entrusted by Technical Committee PRI/88, Plastics piping systems, to Subcommittee PRI/88/4, Test Methods - Plastic Piping.

A list of organizations represented on this committee can be obtained on request to its secretary.

This publication does not purport to include all the necessary provisions of a contract. Users are responsible for its correct application.

© The British Standards Institution 2013

Published by BSI Standards Limited 2013

ISBN 978 0 580 77441 6

ICS 23.040.20; 23.040.45

**Compliance with a British Standard cannot confer immunity from legal obligations.**

This British Standard was published under the authority of the Standards Policy and Strategy Committee on 31 January 2013.

### Amendments issued since publication

Amd. No.	Date	Text affected
----------	------	---------------

---

EUROPEAN STANDARD

**EN ISO 10147**

NORME EUROPÉENNE

EUROPÄISCHE NORM

December 2012

ICS 23.040.20; 23.040.45

Supersedes EN 579:1993

English Version

Pipes and fittings made of crosslinked polyethylene (PE-X) -  
Estimation of the degree of crosslinking by determination of the  
gel content (ISO 10147:2011)

Tubes et raccords en polyéthylène réticulé (PE-X) -  
Estimation du degré de réticulation par le mesurage du  
taux de gel (ISO 10147:2011)

Rohre und Fittings aus vernetztem Polyethylen (PE-X) -  
Berechnung des Grades der Vernetzung durch  
Bestimmung des Gel-Gehaltes (ISO 10147:2011)

This European Standard was approved by CEN on 10 August 2012.

CEN members are bound to comply with the CEN/CENELEC Internal Regulations which stipulate the conditions for giving this European Standard the status of a national standard without any alteration. Up-to-date lists and bibliographical references concerning such national standards may be obtained on application to the CEN-CENELEC Management Centre or to any CEN member.

This European Standard exists in three official versions (English, French, German). A version in any other language made by translation under the responsibility of a CEN member into its own language and notified to the CEN-CENELEC Management Centre has the same status as the official versions.

CEN members are the national standards bodies of Austria, Belgium, Bulgaria, Croatia, Cyprus, Czech Republic, Denmark, Estonia, Finland, Former Yugoslav Republic of Macedonia, France, Germany, Greece, Hungary, Iceland, Ireland, Italy, Latvia, Lithuania, Luxembourg, Malta, Netherlands, Norway, Poland, Portugal, Romania, Slovakia, Slovenia, Spain, Sweden, Switzerland, Turkey and United Kingdom.



EUROPEAN COMMITTEE FOR STANDARDIZATION  
COMITÉ EUROPÉEN DE NORMALISATION  
EUROPÄISCHES KOMITEE FÜR NORMUNG

**Management Centre: Avenue Marnix 17, B-1000 Brussels**

## Contents

Page

Foreword.....	3
---------------	---

## Foreword

The text of ISO 10147:2011 has been prepared by Technical Committee ISO/TC 138 "Plastics pipes, fittings and valves for the transport of fluids" of the International Organization for Standardization (ISO) and has been taken over as EN ISO 10147:2012 by Technical Committee CEN/TC 155 "Plastics piping systems and ducting systems" the secretariat of which is held by NEN.

This European Standard shall be given the status of a national standard, either by publication of an identical text or by endorsement, at the latest by June 2013, and conflicting national standards shall be withdrawn at the latest by June 2013.

Attention is drawn to the possibility that some of the elements of this document may be the subject of patent rights. CEN [and/or CENELEC] shall not be held responsible for identifying any or all such patent rights.

This document supersedes EN 579:1993.

According to the CEN/CENELEC Internal Regulations, the national standards organisations of the following countries are bound to implement this European Standard: Austria, Belgium, Bulgaria, Croatia, Cyprus, Czech Republic, Denmark, Estonia, Finland, Former Yugoslav Republic of Macedonia, France, Germany, Greece, Hungary, Iceland, Ireland, Italy, Latvia, Lithuania, Luxembourg, Malta, Netherlands, Norway, Poland, Portugal, Romania, Slovakia, Slovenia, Spain, Sweden, Switzerland, Turkey and the United Kingdom.

### Endorsement notice

The text of ISO 10147:2011 has been approved by CEN as a EN ISO 10147:2012 without any modification.

# Pipes and fittings made of crosslinked polyethylene (PE-X) — Estimation of the degree of crosslinking by determination of the gel content

## 1 Scope

This International Standard specifies a method for the assessment of the degree of crosslinking in crosslinked polyethylene (PE-X) pipes and fittings by determination of the gel content by solvent extraction.

## 2 Principle

The mass of a test piece taken from a pipe or a fitting is measured before and after immersion of the test piece in a solvent for a specified period of time. The degree of crosslinking is expressed as the percentage by mass of the insoluble material.

For the minimum applicable values for the degree of crosslinking refer to the product or system standards.

## 3 Solvent

**3.1 Xylene**, an isomeric mixture with a purity  $\geq 98$  % volume fraction and a boiling range of 137 °C to 144 °C, to which a 1 % volume fraction of antioxidant has been added.

The antioxidant may be either 2,2-methylene-*bis*(4-methyl-6-*tert*-butylphenol) or antioxidants based on 3-(3,5-di-*tert*-butyl-4-hydroxyphenyl) propionate or a combination of these.

**WARNING — Xylene is a harmful and inflammable solvent that can be absorbed through the skin and, as such, should be handled carefully. Attention is drawn to any relevant regulations and associated exposure limits. Use only in a ventilated hood. Check the effectiveness of the hood before starting the test. Do not inhale the vapour. The appropriate safety equipment should be worn. Excessive inhalation of the vapour may cause dizziness, headache or both. In the event of excessive vapour inhalation, seek fresh, clean air.**

## 4 Apparatus

The following apparatus is required in order to carry out the test.

**4.1 Reflux condenser**, of the general type shown in Figure 1.

**4.2 Round-bottomed flask**, of at least 500 ml capacity.

**4.3 Heating mantle**, to fit the flask (4.2), and with sufficient heating capacity to boil xylene (boiling range: 137 °C to 144 °C).

**4.4 Cage**, with lid, large enough to contain a test piece (see Clause 5).

The cage shall be made of wire cloth or mesh, of aluminium or stainless steel, with a pore size of  $(125 \pm 25)$   $\mu\text{m}$  and sufficient to retain the sample. The wire cloth or mesh shall be free of grease, oil or other contaminants soluble in xylene. If not, it shall be washed with acetone and dried before use.

**4.5 Lathe with automatic feed**, for machining out test pieces, or **microtome** or **other suitable cutting tool**.

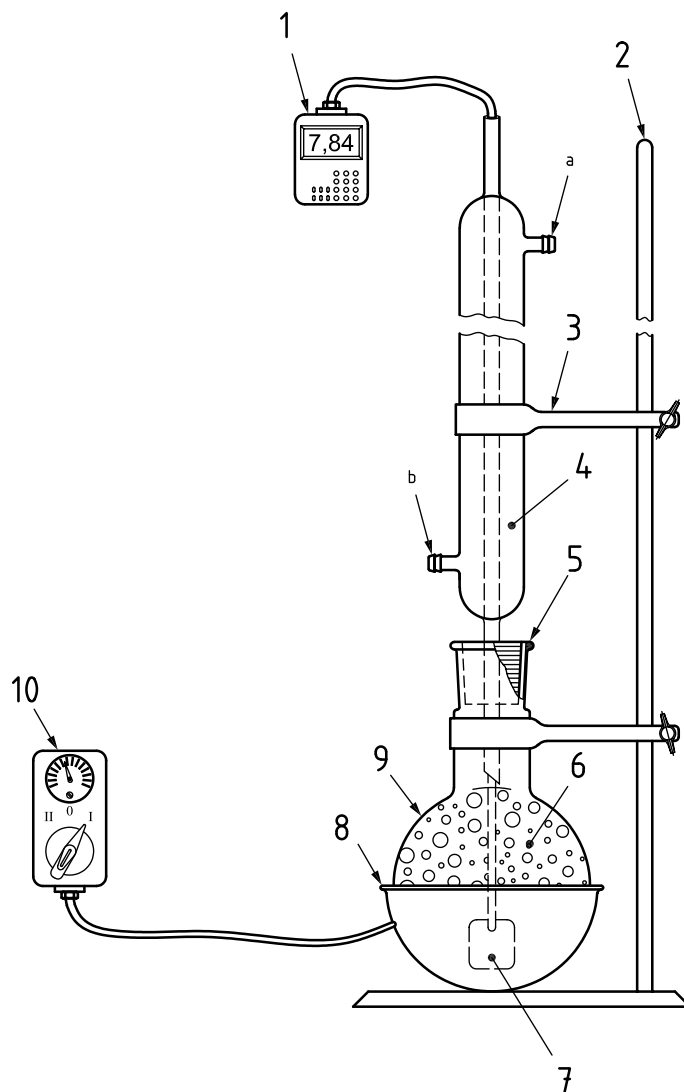

**Key**

- 1 identification tag and fine wire attached to cage
  - 2 stand
  - 3 ring clamp
  - 4 reflux condenser
  - 5 ground-glass joint or cork
  - 6 xylene
  - 7 wire cage enclosing test piece
  - 8 heating mantle
  - 9 wide-necked round-bottomed flask
  - 10 variable transformer
- a Water out.  
b Water in.

**Figure 1 — Extraction apparatus**

**4.6 Vacuum oven or forced-ventilation oven**, capable of maintaining the specified conditions (see 6.6).

**4.7 Balance**, capable of weighing the cage, with or without a test piece, to an accuracy of 1 mg.

## 5 Preparation of test pieces

The test pieces are prepared in accordance with the following instructions.

Any protective layer on the pipe or test sample shall be removed prior to preparation of test pieces.

Unless otherwise specified in the referring standard, at least two test pieces shall be prepared.

Each test piece shall comprise a slice or shaving having a thickness of  $(0,2 \pm 0,02)$  mm, taken from a cross-section of the pipe or fitting to include the full wall thickness round at least one circumference unless specified otherwise by the referring standard. The mass of the test piece shall be  $\geq 0,2$  g.

The degree of crosslinking can vary through the wall thickness of a pipe or fitting and therefore, for surface or midwall measurements, test pieces shall be machined accordingly.

It is recommended that a lathe be used to machine test pieces from pipe. Alternatively, a microtome or other suitable cutting tool can be used to obtain the test pieces from fittings.

## 6 Procedure

**6.1** Weigh a clean, dry cage including the lid (see 4.4), to an accuracy of 1 mg (mass  $m_1$ ).

**6.2** Place a test piece in the cage, close the lid and weigh the cage and test piece together to an accuracy of 1 mg (mass  $m_2$ ).

**6.3** Place the cage and test piece in the flask (4.2) and ensure that there is sufficient xylene solvent to maintain total immersion and to provide a ratio by mass of solvent to test piece of at least 200:1.

The solvent can be re-used after distillation with the addition of a further 1 % volume fraction of antioxidant (3.1). In case of dispute, use a new or freshly distilled solution.

**6.4** Boil the solvent vigorously to ensure good agitation for  $8 \text{ h} \pm 30 \text{ min}$ .

**6.5** Carefully remove the cage and the residue of the test piece from the solution after the time specified in 6.4.

**CAUTION — Take care when removing the cage from the boiling solution (see 3.1).**

**6.6** Complete the drying of the residue, or cage, lid and residue, by placing them for at least 3 h in:

- a) either a vacuum oven (see 4.6), kept at  $(90 \pm 2)$  °C under a vacuum (negative pressure) of at least 0,85 bar (85 kPa), i.e. approximately 0,15 bar absolute pressure or less; or
- b) a forced-ventilation oven (see 4.6), with an adequate extraction facility, kept at  $(140 \pm 2)$  °C.

**6.7** Allow to cool to ambient temperature and weigh the residue (mass  $m_4$ ) or the cage, lid and residue (mass  $m_3$ ) to an accuracy of 1 mg.

## 7 Calculation and expression of results

Calculate the degree of crosslinking,  $G$ , of the material in the individual test pieces as the percentage by mass of the insoluble material, using one of the following equations as appropriate:



when only the residue was weighed:

$$G = \frac{m_4}{m_2 - m_1} \times 100$$

when the cage, lid and residue were weighed:

$$G = \frac{m_3 - m_1}{m_2 - m_1} \times 100$$

where

$m_1$  is the mass of the cage and lid, in milligrams;

$m_2$  is the mass of the original test piece, the cage and the lid, in milligrams;

$m_3$  is the mass of the residue, cage and lid, in milligrams;

$m_4$  is the mass of the residue, in milligrams.

Express the result to the nearest whole number.

The mass of any filler present in the material shall be taken into account.

The average degree of crosslinking,  $G_a$ , can be calculated from the individual results of a number of samples.

## 8 Test report

The test report shall include the following information:

- a) a reference to this International Standard, i.e ISO 10147, and, if applicable, to the standards making reference to this one;
- b) all details necessary for the identification of the test piece;
- c) the degree of crosslinking,  $G$ , for the individual test pieces and the average,  $G_a$ , stating the number of samples tested;
- d) details of any variation in the specified procedure and of any abnormal behaviour observed during the test;
- e) the date of the test.





# British Standards Institution (BSI)

BSI is the national body responsible for preparing British Standards and other standards-related publications, information and services.

BSI is incorporated by Royal Charter. British Standards and other standardization products are published by BSI Standards Limited.

## About us

We bring together business, industry, government, consumers, innovators and others to shape their combined experience and expertise into standards-based solutions.

The knowledge embodied in our standards has been carefully assembled in a dependable format and refined through our open consultation process. Organizations of all sizes and across all sectors choose standards to help them achieve their goals.

## Information on standards

We can provide you with the knowledge that your organization needs to succeed. Find out more about British Standards by visiting our website at [bsigroup.com/standards](http://bsigroup.com/standards) or contacting our Customer Services team or Knowledge Centre.

## Buying standards

You can buy and download PDF versions of BSI publications, including British and adopted European and international standards, through our website at [bsigroup.com/shop](http://bsigroup.com/shop), where hard copies can also be purchased.

If you need international and foreign standards from other Standards Development Organizations, hard copies can be ordered from our Customer Services team.

## Subscriptions

Our range of subscription services are designed to make using standards easier for you. For further information on our subscription products go to [bsigroup.com/subscriptions](http://bsigroup.com/subscriptions).

With **British Standards Online (BSOL)** you'll have instant access to over 55,000 British and adopted European and international standards from your desktop. It's available 24/7 and is refreshed daily so you'll always be up to date.

You can keep in touch with standards developments and receive substantial discounts on the purchase price of standards, both in single copy and subscription format, by becoming a **BSI Subscribing Member**.

**PLUS** is an updating service exclusive to BSI Subscribing Members. You will automatically receive the latest hard copy of your standards when they're revised or replaced.

To find out more about becoming a BSI Subscribing Member and the benefits of membership, please visit [bsigroup.com/shop](http://bsigroup.com/shop).

With a **Multi-User Network Licence (MUNL)** you are able to host standards publications on your intranet. Licences can cover as few or as many users as you wish. With updates supplied as soon as they're available, you can be sure your documentation is current. For further information, email [bsmusales@bsigroup.com](mailto:bsmusales@bsigroup.com).

## BSI Group Headquarters

389 Chiswick High Road London W4 4AL UK

## Revisions

Our British Standards and other publications are updated by amendment or revision.

We continually improve the quality of our products and services to benefit your business. If you find an inaccuracy or ambiguity within a British Standard or other BSI publication please inform the Knowledge Centre.

## Copyright

All the data, software and documentation set out in all British Standards and other BSI publications are the property of and copyrighted by BSI, or some person or entity that owns copyright in the information used (such as the international standardization bodies) and has formally licensed such information to BSI for commercial publication and use. Except as permitted under the Copyright, Designs and Patents Act 1988 no extract may be reproduced, stored in a retrieval system or transmitted in any form or by any means – electronic, photocopying, recording or otherwise – without prior written permission from BSI. Details and advice can be obtained from the Copyright & Licensing Department.

## Useful Contacts:

### Customer Services

**Tel:** +44 845 086 9001

**Email (orders):** [orders@bsigroup.com](mailto:orders@bsigroup.com)

**Email (enquiries):** [cservices@bsigroup.com](mailto:cservices@bsigroup.com)

### Subscriptions

**Tel:** +44 845 086 9001

**Email:** [subscriptions@bsigroup.com](mailto:subscriptions@bsigroup.com)

### Knowledge Centre

**Tel:** +44 20 8996 7004

**Email:** [knowledgecentre@bsigroup.com](mailto:knowledgecentre@bsigroup.com)

### Copyright & Licensing

**Tel:** +44 20 8996 7070

**Email:** [copyright@bsigroup.com](mailto:copyright@bsigroup.com)



...making excellence a habit.™