

BS EN ISO 10139-2:2016



BSI Standards Publication

Dentistry — Soft lining materials for removable dentures

Part 2: Materials for long-term use (ISO 10139-2:2016)

National foreword

This British Standard is the UK implementation of EN ISO 10139-2:2016. It supersedes BS EN ISO 10139-2:2009 which is withdrawn.

The UK participation in its preparation was entrusted to Technical Committee CH/106/2, Prosthodontic materials.

A list of organizations represented on this committee can be obtained on request to its secretary.

This publication does not purport to include all the necessary provisions of a contract. Users are responsible for its correct application.

© The British Standards Institution 2016. Published by BSI Standards Limited 2016

ISBN 978 0 580 92758 4

ICS 11.060.10

Compliance with a British Standard cannot confer immunity from legal obligations.

This British Standard was published under the authority of the Standards Policy and Strategy Committee on 31 July 2016.

Amendments issued since publication

Date	Text affected
------	---------------

EUROPEAN STANDARD

EN ISO 10139-2

NORME EUROPÉENNE

EUROPÄISCHE NORM

July 2016

ICS 11.060.10

Supersedes EN ISO 10139-2:2009

English Version

Dentistry - Soft lining materials for removable dentures - Part 2: Materials for long-term use (ISO 10139-2:2016)

Médecine bucco-dentaire - Produits souples pour
intradors de prothèses dentaires amovibles - Partie 2:
Produits pour usage à long terme (ISO 10139-2:2016)

Zahnheilkunde - Weichbleibende
Unterfütterungswerkstoffe für Prothesen - Teil 2:
Werkstoffe für die Langzeitanwendung (ISO/FDIS
10139-2:2016)

This European Standard was approved by CEN on 12 May 2016.

CEN members are bound to comply with the CEN/CENELEC Internal Regulations which stipulate the conditions for giving this European Standard the status of a national standard without any alteration. Up-to-date lists and bibliographical references concerning such national standards may be obtained on application to the CEN-CENELEC Management Centre or to any CEN member.

This European Standard exists in three official versions (English, French, German). A version in any other language made by translation under the responsibility of a CEN member into its own language and notified to the CEN-CENELEC Management Centre has the same status as the official versions.

CEN members are the national standards bodies of Austria, Belgium, Bulgaria, Croatia, Cyprus, Czech Republic, Denmark, Estonia, Finland, Former Yugoslav Republic of Macedonia, France, Germany, Greece, Hungary, Iceland, Ireland, Italy, Latvia, Lithuania, Luxembourg, Malta, Netherlands, Norway, Poland, Portugal, Romania, Slovakia, Slovenia, Spain, Sweden, Switzerland, Turkey and United Kingdom.



EUROPEAN COMMITTEE FOR STANDARDIZATION
COMITÉ EUROPÉEN DE NORMALISATION
EUROPÄISCHES KOMITEE FÜR NORMUNG

CEN-CENELEC Management Centre: Avenue Marnix 17, B-1000 Brussels

European foreword

This document (EN ISO 10139-2:2016) has been prepared by Technical Committee ISO/TC 106 “Dentistry” in collaboration with Technical Committee CEN/TC 55 “Dentistry” the secretariat of which is held by DIN.

This European Standard shall be given the status of a national standard, either by publication of an identical text or by endorsement, at the latest by January 2017, and conflicting national standards shall be withdrawn at the latest by January 2017.

Attention is drawn to the possibility that some of the elements of this document may be the subject of patent rights. CEN [and/or CENELEC] shall not be held responsible for identifying any or all such patent rights.

This document supersedes EN ISO 10139-2:2009.

According to the CEN-CENELEC Internal Regulations, the national standards organizations of the following countries are bound to implement this European Standard: Austria, Belgium, Bulgaria, Croatia, Cyprus, Czech Republic, Denmark, Estonia, Finland, Former Yugoslav Republic of Macedonia, France, Germany, Greece, Hungary, Iceland, Ireland, Italy, Latvia, Lithuania, Luxembourg, Malta, Netherlands, Norway, Poland, Portugal, Romania, Slovakia, Slovenia, Spain, Sweden, Switzerland, Turkey and the United Kingdom.

Endorsement notice

The text of ISO 10139-2:2016 has been approved by CEN as EN ISO 10139-2:2016 without any modification.

Contents

Page

Foreword	iv
Introduction	v
1 Scope	1
2 Normative references	1
3 Terms and definitions	1
4 Classification	2
5 Requirements	2
5.1 Shore A hardness, 24 h.....	2
5.2 Shore A hardness, 30 d.....	2
5.3 Bond strength.....	2
5.4 Sorption.....	2
5.5 Solubility.....	2
6 Sampling	3
7 Test methods	3
7.1 Test conditions.....	3
7.2 Shore A hardness.....	3
7.2.1 Apparatus.....	3
7.2.2 Preparation of test samples.....	3
7.2.3 Procedure.....	3
7.2.4 Expression of results.....	4
7.3 Bond strength.....	4
7.3.1 Materials.....	4
7.3.2 Preparation of acrylic denture base plates.....	4
7.3.3 Preparation of test specimens.....	5
7.3.4 Procedure for tensile testing.....	5
7.4 Water sorption and solubility.....	6
7.4.1 Materials.....	6
7.4.2 Apparatus.....	7
7.4.3 Preparation of test specimens.....	8
7.4.4 Procedure.....	8
7.4.5 Calculation and expression of results.....	9
8 Requirements for packaging, marking and instructions supplied by manufacturer	9
8.1 Packaging.....	9
8.2 Marking.....	9
8.3 Manufacturer's instructions for use.....	10
Bibliography	12

Foreword

ISO (the International Organization for Standardization) is a worldwide federation of national standards bodies (ISO member bodies). The work of preparing International Standards is normally carried out through ISO technical committees. Each member body interested in a subject for which a technical committee has been established has the right to be represented on that committee. International organizations, governmental and non-governmental, in liaison with ISO, also take part in the work. ISO collaborates closely with the International Electrotechnical Commission (IEC) on all matters of electrotechnical standardization.

The procedures used to develop this document and those intended for its further maintenance are described in the ISO/IEC Directives, Part 1. In particular the different approval criteria needed for the different types of ISO documents should be noted. This document was drafted in accordance with the editorial rules of the ISO/IEC Directives, Part 2 (see www.iso.org/directives).

Attention is drawn to the possibility that some of the elements of this document may be the subject of patent rights. ISO shall not be held responsible for identifying any or all such patent rights. Details of any patent rights identified during the development of the document will be in the Introduction and/or on the ISO list of patent declarations received (see www.iso.org/patents).

Any trade name used in this document is information given for the convenience of users and does not constitute an endorsement.

For an explanation on the meaning of ISO specific terms and expressions related to conformity assessment, as well as information about ISO's adherence to the WTO principles in the Technical Barriers to Trade (TBT) see the following URL: [Foreword - Supplementary information](#)

The committee responsible for this document is ISO/TC 106, *Dentistry*, Subcommittee SC 2, *Prosthetic materials*.

This third edition cancels and replaces the second edition (ISO 10139-2:2009), of which it constitutes a minor revision to harmonize the definition of long-term use with other international definitions (30 days).

ISO 10139 consists of the following parts, under the general title *Dentistry — Soft lining materials for removable dentures*:

- *Part 1: Materials for short-term use*
- *Part 2: Materials for long-term use*

Introduction

Denture lining materials for long-term use are classified in this part of ISO 10139 according to their softness. Although it is not claimed that any particular level of softness is superior to another, this classification is intended to assist clinicians because clinicians will have more information with which to make an informed choice.

Specific qualitative and quantitative requirements for freedom from biological hazard are not included in this part of ISO 10139. Information relevant to assessing possible biological or toxicological hazards is given in ISO 7405 and ISO 10993-1.

Dentistry — Soft lining materials for removable dentures —

Part 2: Materials for long-term use

1 Scope

This part of ISO 10139 specifies requirements for softness, adhesion, water sorption and water solubility, as well as for packaging, marking and manufacturer's instructions for soft denture lining materials suitable for long-term use. These materials may also be used for maxillofacial prostheses.

2 Normative references

The following referenced documents, in whole or in part, are normatively referenced in this document and are indispensable for its application. For dated references, only the edition cited applies. For undated references, the latest edition of the referenced document (including any amendments) applies.

ISO 1942, *Dentistry — Vocabulary*

ISO 3696, *Water for analytical laboratory use — Specification and test methods*

ISO 6344-1, *Coated abrasives — Grain size analysis — Part 1: Grain size distribution test*

ISO 7619-1, *Rubber, vulcanized or thermoplastic — Determination of indentation hardness — Part 1: Durometer method (Shore hardness)*

ISO 8601, *Data elements and interchange formats — Information interchange — Representation of dates and times*

ISO 20795-1, *Dentistry — Base polymers — Part 1: Denture base polymers*

3 Terms and definitions

For the purposes of this document, the terms and definitions given in ISO 1942 and the following apply.

3.1

soft denture lining material

soft resilient material bonded to the fitting surface of a denture to reduce trauma to the supporting tissues

3.2

long-term use

use for a period of more than 30 d

3.3

immediate container

container that is in direct contact with the material

4 Classification

Soft lining materials for long-term use are classified into the following types according to Shore A hardness of 24 h specimens (5.1) as determined in accordance with 7.2:

- **Type A:** soft;
- **Type B:** extra soft.

5 Requirements

5.1 Shore A hardness, 24 h

When 24 h test specimens are subjected to a 5 s Shore A hardness test in accordance with 7.2.3.2, the material shall conform to the requirements for the relevant type as shown in Table 1. For a material to be classified as a particular type, the mean Shore A hardness for at least two of the three specimens shall conform to the requirements for that type, as specified in Table 1. If the results for two or more specimens are greater than 50, the material shall be deemed not to conform to this part of ISO 10139.

Table 1 — Shore A hardness, 24 h – 5 s

Type	Shore A (24 h – 5 s)
A (soft)	$25 < \text{Shore A} \leq 50$
B (extra soft)	$\text{Shore A} \leq 25$

5.2 Shore A hardness, 30 d

When 30 d test specimens are subjected to a 5 s Shore A hardness test in accordance with 7.2.3.3, the material shall conform to the requirements for the relevant type as shown in Table 2 for at least two of the three specimens. If the results for two or more specimens are greater than 55 for Type A materials or greater than 35 for Type B materials, the material shall be deemed not to conform to this part of ISO 10139.

Table 2 — Shore A hardness, 30 d – 5 s

Type	Shore A (30 d – 5 s)
A (soft)	≤ 55
B (extra soft)	≤ 35

5.3 Bond strength

The bond strength of the lining material to denture base shall be at least 1,0 MPa for eight out of 10 tested specimens for Type A materials and at least 0,5 MPa for eight out of ten tested specimens for Type B materials when tested in accordance with 7.3.

5.4 Sorption

The increase in mass per volume (water sorption) shall not exceed $20 \mu\text{g}/\text{mm}^3$ for at least four out of five tested specimens when the processed lining material is tested in accordance with 7.4.

5.5 Solubility

The loss in mass per volume (water solubility) shall not exceed $3 \mu\text{g}/\text{mm}^3$ for at least four out of five tested specimens when the processed lining material is tested in accordance with 7.4.

If the loss in mass per volume (water solubility) does exceed $3 \mu\text{g}/\text{mm}^3$ for at least two out of five tested specimens when the processed lining material is tested in accordance with [7.4](#), the manufacturer of the material shall state the amount and the nature of the solubles from the material.

6 Sampling

The test sample shall consist of a retail package, or packages, from the same batch and containing enough material to carry out the specified tests, plus an allowance for any repeat tests, if necessary.

7 Test methods

7.1 Test conditions

Unless specified otherwise by the manufacturer, prepare and test all specimens at a temperature of $(23 \pm 2) ^\circ\text{C}$. Measurement equipment shall be used in a calibrated condition.

7.2 Shore A hardness

7.2.1 Apparatus

7.2.1.1 Shore A hardness equipment, corresponding to ISO 7619-1 with a precision of ± 1 HS.

7.2.1.2 Water bath, capable of being maintained at $(37 \pm 1) ^\circ\text{C}$, with water complying with grade 2 of ISO 3696.

7.2.1.3 Mould, suitable for producing test specimens of at least 35 mm diameter and at least 6 mm thick, constructed using a smooth metal or polymer disc as a template. A mould release agent, e.g. Polytetrafluoroethylene (PTFE) spray, may be used to avoid the adherence of material.

7.2.1.4 Timing device, accurate to 0,1 s.

7.2.2 Preparation of test samples

Prepare each test specimen in the mould cavity in accordance with the manufacturer's instructions. Remove the specimen from the mould ([7.2.1.3](#)) and store it in the water bath ([7.2.1.2](#)) at $(37 \pm 1) ^\circ\text{C}$ for (24 ± 1) h prior to testing. Prepare the three test specimens.

7.2.3 Procedure

7.2.3.1 General

Carry out the test procedure in accordance with [7.2.3.2](#), [7.2.3.3](#) and ISO 7619-1 on each of the three test specimens. For the measurements, place the specimens on a flat and solid base and lower the Shore A hardness tester ([7.2.1.1](#)) gradually onto the surface of the specimen in such a way that the indenter foot just touches the specimen surface. The surface of the specimens and the contact surface of the Shore A hardness tester shall be coplanar. Ensure that the indenter is normal to the specimen surface. Five measurements shall be made for each of the specimens at each testing time. The loading points shall be uniformly distributed on the surface and shall have a distance of at least 5 mm from the edge of the specimen.

7.2.3.2 Shore A hardness test, 24 h specimen

Remove the specimen from the water ([7.2.1.2](#)) bath 24 h after preparation and measure the Shore A hardness immediately. Record the values 5 s after loading, using a timing device ([7.2.1.4](#)). Make

all recordings within (2 ± 1) min of having removed the specimen from the water bath. Return the specimens to the water bath. Calculate the mean of the five Shore A values for each of the three specimens (results a, b and c).

Return the specimens to the water bath and maintain them in it for an additional 29 d. Change the water every 7 d with water complying with grade 2 of ISO 3696.

7.2.3.3 Shore A hardness test, 30 d specimen

Remove the specimen from the water bath (7.2.1.2) 29 d after the first testing and measure the Shore A hardness immediately. Record the values 5 s after the loading using a timing device (7.2.1.4). Make all recordings within (2 ± 1) min after having removed the specimen from the water bath. Use fresh loading points and ensure that no measurement is made closer than 2 mm to a previous one. Calculate the mean of the five Shore A values for each of the three specimens (results x, y and z).

7.2.4 Expression of results

Record the test results for each of the three specimens in the format illustrated in Table 3.

Table 3 — Shore A hardness

Age of specimen	Mean Shore A of specimen		
	1	2	3
24 h	a	b	c
30 d	x	y	z

7.3 Bond strength

7.3.1 Materials

7.3.1.1 Acrylic denture base material, in accordance with the instruction given in 8.3 g) and complying with ISO 20795-1.

7.3.1.2 Standard metallographic grinding paper, P500 in accordance with ISO 6344-1 (with a median grain size of 30 μm).

7.3.1.3 Water bath, capable of maintaining a constant temperature of (37 ± 1) °C, with water complying with grade 2 of ISO 3696.

7.3.1.4 Collars, made from polyethylene or other non-adhering materials, cut from suitable tubing, with an internal diameter of $(10 \pm 0,5)$ mm and a thickness of $(3 \pm 0,25)$ mm.

7.3.1.5 Micrometer or calliper, accurate to 0,01 mm and fitted with parallel anvils.

7.3.1.6 Clamp, such as G-cramp or similar.

7.3.1.7 Tensile testing machine, with a vertical set-up, capable of an even displacement of 10 mm/min.

7.3.2 Preparation of acrylic denture base plates

Prepare sufficient plates of the dimension (25 ± 3) mm² and $(3 \pm 0,5)$ mm thick of the acrylic denture base material (7.3.1.1) by the method recommended by the manufacturer. Prepare the specimens in gypsum casts using the recommended curing cycle. The plates may be made individually or cut from larger pieces (up to 80 mm \times 80 mm).

Maintain the flat surfaces of the plates in plano-parallel configuration while the surfaces are ground (wet) using P500 paper (7.3.1.2) ensuring that the dimensions of the individual plates still conform to the dimensions above. Avoid touching the bonding surface after grinding.

Store the plates for $(30 \pm 2) d$ in the water bath (7.3.1.3) at $(37 \pm 1) ^\circ\text{C}$ before use.

Measure the internal diameter of the polyethylene collar (7.3.1.4) with the micrometer or calliper (7.3.1.5) to a precision of 0,05 mm and use this to calculate the adhesive area, A , in square millimetres.

7.3.3 Preparation of test specimens

Use the lining material and the adhesive supplied by the manufacturer according to the instructions for mixing, application and setting.

Immediately after removing the acrylic plates from the storage water, dry as recommended by the manufacturer or by using the method described in 7.4.4.2, and apply the adhesive to both surfaces of the acrylic plates that will be involved in bonding, following manufacturer's instructions. Make sure not to touch the adhesive surface.

Apply the prepared (mixed) soft lining material to the adhesive surfaces of the acrylic plates using slight excess while being confined within the collar (7.3.1.4) (see Figure 1). Clamp (7.3.1.6) the plates during setting. Maintain the clamped arrangement at room temperature $(23 \pm 2) ^\circ\text{C}$, unless curing at a higher temperature is recommended. At 1 h after application of the soft material to the base, place the bonded specimen into the water bath (7.3.1.3) at $(37 \pm 1) ^\circ\text{C}$ for $(23 \pm 1) \text{ h}$.

Prepare a minimum of 10 test specimens.

7.3.4 Procedure for tensile testing

Remove the specimen from the water bath and immediately transfer it to a tensile testing machine (7.3.1.7). Fix the specimen in the testing machine in a vertical alignment. Ensure that no torsion forces are made upon the specimen and keep the specimen in vertical alignment during testing. This may be facilitated using sections of a PMMA rod bonded to the acrylic plates with cyanoacrylate cement (see Figure 1). The PMMA rod may be applied just before testing or immediately after making the bond.

Carry out the tensile test at a displacement rate of 10 mm/min. Record the maximum load, F , recorded during debonding.

Repeat the test for a total of 10 specimens and calculate each bond strength, B , (in MPa) according to Formula (1):

$$B = \frac{F}{A} \quad (1)$$

where

F is the maximum load, in Newtons, before debonding;

A is the adhesive area, in square millimetres.

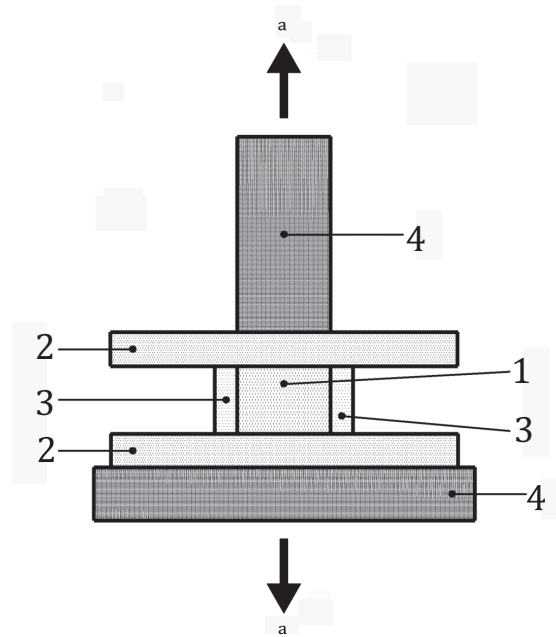

Key

- 1 test material (lining material)
- 2 acrylic denture base plates
- 3 collar
- 4 PMMA-rods (optional)
- a Direction of the tensile stress.

Figure 1 — Tensile test setup for bond strength measurement

7.4 Water sorption and solubility

7.4.1 Materials

7.4.1.1 Sheet of polyester film, having a thickness of $(50 \pm 25) \mu\text{m}$ to cover the steel mould ([7.4.2.1](#)).

7.4.1.2 Silica gel, freshly dried for (300 ± 10) min at $(130 \pm 5) ^\circ\text{C}$.

7.4.1.3 Water, complying with grade 2 of ISO 3696.

Dimensions in millimetres

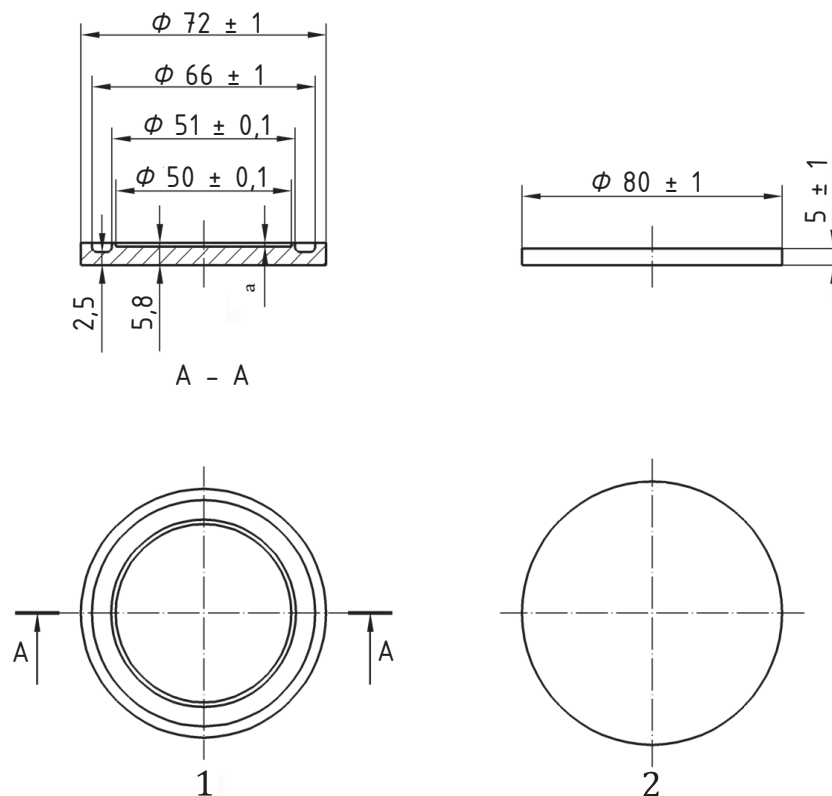

Key

- 1 mould
- 2 cover
- a Mould depth ($0,5 \pm 0,05$) mm to form specimen.

NOTE Dimensional tolerances not specified are $\pm 0,2$ mm.

Figure 2 — Stainless steel mould and cover for specimen preparation for water sorption and solubility

7.4.2 Apparatus

7.4.2.1 Circular stainless steel mould and cover, having the dimensions shown in [Figure 2](#), mounted in gypsum in separate halves of a denture flask.

7.4.2.2 Hydraulic or hand press and clamp, where applicable.

7.4.2.3 Micrometer or dial calliper, accurate to 0,01 mm and fitted with parallel anvils.

7.4.2.4 Rack, to keep the specimens parallel and separated.

7.4.2.5 Two desiccators.

7.4.2.6 Oven, maintained at (37 ± 1) °C.

7.4.2.7 Polymer-coated tweezers.

7.4.2.8 Towel, clean and dry.

7.4.2.9 Analytical balance, accurate to 0,1 mg.

7.4.3 Preparation of test specimens

Make five specimens from separate mixes. Mix the lining material and pack the mixture into the mould (7.4.2.1) with the polyester film (7.4.1.1) against the steel cover of the mould. Process the mixture in accordance with the manufacturer's instructions, but retain the polyester film during the processing cycle.

Check with a micrometer or dial calliper (7.4.2.3) to ensure that each specimen has a diameter of (50 ± 1) mm and a thickness of $(0,5 \pm 0,1)$ mm and that the top and bottom surfaces are flat.

7.4.4 Procedure

7.4.4.1 Conditioned specimens

Place the specimens in the rack (7.4.2.4) inside one of the desiccators (7.4.2.5) containing freshly dried silica gel (7.4.1.2). Store the desiccator in the oven (7.4.2.6) at (37 ± 1) °C for (23 ± 1) h and then remove the desiccator from the oven.

Transfer the specimens kept in the rack directly to the second desiccator which has been supplied with freshly dried silica gel. The second desiccator is kept at (23 ± 2) °C. After (60 ± 10) min in the second desiccator, the specimens are ready for weighing.

Use an analytical balance (7.4.2.9) to weigh the specimen to an accuracy of 0,1 mg. Keep the desiccator sealed except for the shortest possible period required for removing and replacing specimens. After all the specimens have been weighed, replace the silica gel in the first desiccator with freshly dried gel and place the desiccator in the oven.

Repeat the cycle described until a constant mass, m_1 , to be called the "conditioned mass", is reached, i.e. until the loss in mass of each specimen is not more than 0,2 mg between successive weighings. At this point, measure the diameter and the thickness of each specimen to an accuracy of 0,01 mm. Calculate the volume, V , of each specimen using the mean of three diameter measurements and the mean of five thickness measurements. The thickness measurements are taken in the centre and at four equally spaced locations around the circumference.

7.4.4.2 Wet specimens

Immerse the conditioned specimens in water (7.4.1.3) at (37 ± 1) °C for $7 \text{ d} \pm 2 \text{ h}$. After this time, remove the discs from the water with polymer-coated tweezers (7.4.2.7), wipe with a clean, dry towel (7.4.2.8) until free from visible moisture, wave in the air for (15 ± 1) s and weigh (60 ± 10) s after removal from the water (to an accuracy of 0,1 mg). Record the mass as m_2 .

7.4.4.3 Reconditioned specimens

After this weighing, recondition the specimens to constant mass in the desiccator as described in 7.4.4.1. Record the mass of the "reconditioned" specimens as m_3 .

It is essential that the same conditions be applied as for the first drying process, using the same number of specimens and the freshly dried silica gel in the desiccators.

7.4.5 Calculation and expression of results

7.4.5.1 Water sorption

Calculate the value for the water sorption, w_{sp} , for each of the five specimens, expressed in micrograms per cubic millimetre ($\mu\text{g}/\text{mm}^3$), using [Formula \(2\)](#):

$$w_{sp} = \frac{m_2 - m_3}{V} \quad (2)$$

where

m_2 is the mass of the specimen, in micrograms (μg), after immersion in water (see [7.4.4.2](#));

m_3 is the reconditioned mass of the specimen, in micrograms (μg) (see [7.4.4.3](#));

V is the volume of the specimen, in cubic millimetres (mm^3) (see [7.4.4.1](#)).

Round off the calculated values for water sorption to the nearest microgram per cubic millimetre ($\mu\text{g}/\text{mm}^3$).

7.4.5.2 Water solubility

Calculate the soluble matter per unit volume, w_{sl} , leached out during immersion, expressed in micrograms per cubic millimetre ($\mu\text{g}/\text{mm}^3$), for each of the five specimens using [Formula \(3\)](#):

$$w_{sl} = \frac{m_1 - m_3}{V} \quad (3)$$

where

m_1 is the conditioned mass of the specimen, in microgram (μg) (see [7.4.4.1](#));

m_3 and V are as given in [7.4.5.1](#).

Round off the values calculated for water solubility to the nearest $0,1 \mu\text{g}/\text{mm}^3$.

8 Requirements for packaging, marking and instructions supplied by manufacturer

8.1 Packaging

The components shall be supplied in sealed immediate containers made of materials which shall neither contaminate nor permit contamination of the contents. The immediate containers shall be packaged so as to prevent damage or leakage during transit and storage.

An outer package may also be used to present the immediate containers as a single unit.

8.2 Marking

The outer packages and, if appropriate, the immediate containers or wrappings of the components, shall be clearly marked with the following information:

- a) the trade name of the product;
- b) the manufacturer's name or trademark and address, or those of the agent in the country of sale;

- c) the description of the contents including the following:
 - 1) the type of material, according to Shore A hardness, as determined in accordance with [7.2](#);
 - 2) the number of this part of ISO 10139, i.e. ISO 10139-2;
 - 3) the chemical nature of the system, for example, heat-polymerizable or auto-polymerizable acrylic polymer, and silicone;
 - 4) a statement that the product is a soft lining material for long-term use in removable dentures or maxillofacial prostheses;
 - 5) the amount and type of solubles (if the solubility of the material is greater than 3 µg/mm³, see [5.5](#));
- d) the net content of the components, expressed in grams or millilitres;
- e) the batch code (lot number) of the material;
- f) the expiry date, expressed according to ISO 8601, beyond which the material might not exhibit its required properties (year, month);
- g) the recommended conditions of storage;
- h) any hazard warnings, where appropriate, for toxic, hazardous, inflammable or irritating characteristics and flash point of liquid;
- i) any pharmaceutically active ingredient present and referred to in the material claim for use.

In those cases where the size of the immediate container or package is too small to fit in all the details, reference shall be made on the outer package to a leaflet inside which the additional information shall be provided.

8.3 Manufacturer's instructions for use

Instructions for use shall accompany each package and shall include at least the following information:

- a) the information listed in [8.2](#) with the exception of the information in [8.2](#) e) and f);
- b) the fields of application;
- c) the contraindications, side-effects and interactions with other substances, if appropriate;
- d) a detailed description of the working procedure including the following information, where appropriate:
 - 1) an indication of how to prepare the surface of the denture base to be lined;
 - 2) the procedure for mixing or preparing the material, including information on the mixing ratio of the components and, if applicable, the mixing time and working time;
 - 3) the procedure for application to the denture base, flasking and packing;
 - 4) all details of the application procedure, curing procedure, time, temperature, cooling, deflasking and any need for specialized equipment, where applicable;
 - 5) the instructions for finishing and polishing;
 - 6) a statement of any procedure or method to be employed to ensure bonding with the denture base, if appropriate;
- e) any information on the care of the lined denture by the patient and recommendations for cleaning, including reference to any method or material which would be inappropriate for cleaning the lining;

- f) any information on environmental conditions which may adversely affect the material, such as temperature, humidity or ambient light, and the disposal of waste, if precautions are necessary;
- g) the (chemical) type of denture base material(s) recommended for lining.

Bibliography

- [1] ISO 7405, *Dentistry — Evaluation of biocompatibility of medical devices used in dentistry*
- [2] ISO 10993-1, *Biological evaluation of medical devices — Part 1: Evaluation and testing within a risk management process*

British Standards Institution (BSI)

BSI is the national body responsible for preparing British Standards and other standards-related publications, information and services.

BSI is incorporated by Royal Charter. British Standards and other standardization products are published by BSI Standards Limited.

About us

We bring together business, industry, government, consumers, innovators and others to shape their combined experience and expertise into standards-based solutions.

The knowledge embodied in our standards has been carefully assembled in a dependable format and refined through our open consultation process. Organizations of all sizes and across all sectors choose standards to help them achieve their goals.

Information on standards

We can provide you with the knowledge that your organization needs to succeed. Find out more about British Standards by visiting our website at bsigroup.com/standards or contacting our Customer Services team or Knowledge Centre.

Buying standards

You can buy and download PDF versions of BSI publications, including British and adopted European and international standards, through our website at bsigroup.com/shop, where hard copies can also be purchased.

If you need international and foreign standards from other Standards Development Organizations, hard copies can be ordered from our Customer Services team.

Copyright in BSI publications

All the content in BSI publications, including British Standards, is the property of and copyrighted by BSI or some person or entity that owns copyright in the information used (such as the international standardization bodies) and has formally licensed such information to BSI for commercial publication and use.

Save for the provisions below, you may not transfer, share or disseminate any portion of the standard to any other person. You may not adapt, distribute, commercially exploit, or publicly display the standard or any portion thereof in any manner whatsoever without BSI's prior written consent.

Storing and using standards

Standards purchased in soft copy format:

- A British Standard purchased in soft copy format is licensed to a sole named user for personal or internal company use only.
- The standard may be stored on more than 1 device provided that it is accessible by the sole named user only and that only 1 copy is accessed at any one time.
- A single paper copy may be printed for personal or internal company use only.

Standards purchased in hard copy format:

- A British Standard purchased in hard copy format is for personal or internal company use only.
- It may not be further reproduced – in any format – to create an additional copy. This includes scanning of the document.

If you need more than 1 copy of the document, or if you wish to share the document on an internal network, you can save money by choosing a subscription product (see 'Subscriptions').

Reproducing extracts

For permission to reproduce content from BSI publications contact the BSI Copyright & Licensing team.

Subscriptions

Our range of subscription services are designed to make using standards easier for you. For further information on our subscription products go to bsigroup.com/subscriptions.

With **British Standards Online (BSOL)** you'll have instant access to over 55,000 British and adopted European and international standards from your desktop. It's available 24/7 and is refreshed daily so you'll always be up to date.

You can keep in touch with standards developments and receive substantial discounts on the purchase price of standards, both in single copy and subscription format, by becoming a **BSI Subscribing Member**.

PLUS is an updating service exclusive to BSI Subscribing Members. You will automatically receive the latest hard copy of your standards when they're revised or replaced.

To find out more about becoming a BSI Subscribing Member and the benefits of membership, please visit bsigroup.com/shop.

With a **Multi-User Network Licence (MUNL)** you are able to host standards publications on your intranet. Licences can cover as few or as many users as you wish. With updates supplied as soon as they're available, you can be sure your documentation is current. For further information, email subscriptions@bsigroup.com.

Revisions

Our British Standards and other publications are updated by amendment or revision.

We continually improve the quality of our products and services to benefit your business. If you find an inaccuracy or ambiguity within a British Standard or other BSI publication please inform the Knowledge Centre.

Useful Contacts

Customer Services

Tel: +44 345 086 9001

Email (orders): orders@bsigroup.com

Email (enquiries): cservices@bsigroup.com

Subscriptions

Tel: +44 345 086 9001

Email: subscriptions@bsigroup.com

Knowledge Centre

Tel: +44 20 8996 7004

Email: knowledgecentre@bsigroup.com

Copyright & Licensing

Tel: +44 20 8996 7070

Email: copyright@bsigroup.com

BSI Group Headquarters

389 Chiswick High Road London W4 4AL UK