

Dentistry — Soft lining materials for removable dentures —

Part 1: Materials for short-term use

The European Standard EN ISO 10139-1:2005 has the status of a
British Standard

ICS 11.060.10

National foreword

This British Standard is the official English language version of EN ISO 10139-1:2005. It is identical with ISO 10139-1:2005. It supersedes BS EN 30139-1:1994 which is withdrawn.

The UK participation in its preparation was entrusted by Technical Committee CH/106, Dentistry, to Subcommittee CH/106/2, Prosthodontic materials, which has the responsibility to:

- aid enquirers to understand the text;
- present to the responsible international/European committee any enquiries on the interpretation, or proposals for change, and keep UK interests informed;
- monitor related international and European developments and promulgate them in the UK.

A list of organizations represented on this subcommittee can be obtained on request to its secretary.

Cross-references

The British Standards which implement international or European publications referred to in this document may be found in the *BSI Catalogue* under the section entitled “International Standards Correspondence Index”, or by using the “Search” facility of the *BSI Electronic Catalogue* or of British Standards Online.

This publication does not purport to include all the necessary provisions of a contract. Users are responsible for its correct application.

Compliance with a British Standard does not of itself confer immunity from legal obligations.

Summary of pages

This document comprises a front cover, an inside front cover, the EN ISO title page, the EN ISO foreword page, the ISO title page, pages ii to v, a blank page, pages 1 to 10, an inside back cover and a back cover.

The BSI copyright notice displayed in this document indicates when the document was last issued.

Amendments issued since publication

Amd. No.	Date	Comments

This British Standard was published under the authority of the Standards Policy and Strategy Committee on 2 November 2005

© BSI 2 November 2005

ISBN 0 580 46590 X

English version

Dentistry - Soft lining materials for removable dentures - Part 1:
Materials for short-term use (ISO 10139-1:2005)

Art dentaire - Produits souples pour intrados de prothèses
dentaires amovibles - Partie 1: Produits pour usage à court
terme (ISO 10139-1:2005)

Zahnheilkunde - Weichbleibende Unterfütterungswerkstoffe
für Prothesen - Teil 1: Werkstoffe für kurzzeitige
Anwendungen (ISO 10139-1:2005)

This European Standard was approved by CEN on 3 February 2005.

CEN members are bound to comply with the CEN/CENELEC Internal Regulations which stipulate the conditions for giving this European Standard the status of a national standard without any alteration. Up-to-date lists and bibliographical references concerning such national standards may be obtained on application to the Central Secretariat or to any CEN member.

This European Standard exists in three official versions (English, French, German). A version in any other language made by translation under the responsibility of a CEN member into its own language and notified to the Central Secretariat has the same status as the official versions.

CEN members are the national standards bodies of Austria, Belgium, Cyprus, Czech Republic, Denmark, Estonia, Finland, France, Germany, Greece, Hungary, Iceland, Ireland, Italy, Latvia, Lithuania, Luxembourg, Malta, Netherlands, Norway, Poland, Portugal, Slovakia, Slovenia, Spain, Sweden, Switzerland and United Kingdom.



EUROPEAN COMMITTEE FOR STANDARDIZATION
COMITÉ EUROPÉEN DE NORMALISATION
EUROPÄISCHES KOMITEE FÜR NORMUNG

Management Centre: rue de Stassart, 36 B-1050 Brussels

EN ISO 10139-1:2005

Foreword

This document (EN ISO 10139-1:2005) has been prepared by Technical Committee ISO/TC 106 "Dentistry" in collaboration with Technical Committee CEN/TC 55 "Dentistry", the secretariat of which is held by DIN.

This European Standard shall be given the status of a national standard, either by publication of an identical text or by endorsement, at the latest by August 2005, and conflicting national standards shall be withdrawn at the latest by August 2005.

This document supersedes EN 30139-1:1994.

According to the CEN/CENELEC Internal Regulations, the national standards organizations of the following countries are bound to implement this European Standard: Austria, Belgium, Cyprus, Czech Republic, Denmark, Estonia, Finland, France, Germany, Greece, Hungary, Iceland, Ireland, Italy, Latvia, Lithuania, Luxembourg, Malta, Netherlands, Norway, Poland, Portugal, Slovakia, Slovenia, Spain, Sweden, Switzerland and United Kingdom.

Endorsement notice

The text of ISO 10139-1:2005 has been approved by CEN as EN ISO 10139-1:2005 without any modifications.

INTERNATIONAL
STANDARD

ISO
10139-1

Second edition
2005-02-15

**Dentistry — Soft lining materials for
removable dentures —**

Part 1:
Materials for short-term use

*Art dentaire — Produits souples pour intrados de prothèses dentaires
amovibles —*

Partie 1: Produits pour usage à court terme



Reference number
ISO 10139-1:2005(E)

Contents

Page

Foreword	iv
Introduction	v
1 Scope	1
2 Normative references	1
3 Terms and definitions	1
4 Classification	1
4.1 Types	1
4.2 Classes	2
5 Requirements	2
5.1 Development of elastic recovery	2
5.2 Change in compliance with age as measured by depth of penetration	2
6 Sampling	3
7 Test methods	3
7.1 Ambient conditions for testing	3
7.2 Measurement of elastic recovery	3
7.3 Test of compliance as measured by depth of penetration	5
8 Requirement for labelling, marking and instructions supplied by the manufacturer	8
8.1 Packaging	8
8.2 Marking	8
8.3 Manufacturer's instructions for use	9
Bibliography	10

Foreword

ISO (the International Organization for Standardization) is a worldwide federation of national standards bodies (ISO member bodies). The work of preparing International Standards is normally carried out through ISO technical committees. Each member body interested in a subject for which a technical committee has been established has the right to be represented on that committee. International organizations, governmental and non-governmental, in liaison with ISO, also take part in the work. ISO collaborates closely with the International Electrotechnical Commission (IEC) on all matters of electrotechnical standardization.

International Standards are drafted in accordance with the rules given in the ISO/IEC Directives, Part 2.

The main task of technical committees is to prepare International Standards. Draft International Standards adopted by the technical committees are circulated to the member bodies for voting. Publication as an International Standard requires approval by at least 75 % of the member bodies casting a vote.

Attention is drawn to the possibility that some of the elements of this document may be the subject of patent rights. ISO shall not be held responsible for identifying any or all such patent rights.

ISO 10139-1 was prepared by Technical Committee ISO/TC 106, *Dentistry*, Subcommittee SC 2, *Prosthetic materials*.

This second edition cancels and replaces the first edition (ISO 10139-1:1991), which has been technically revised.

ISO 10139 consists of the following parts, under the general title *Dentistry — Soft lining materials for removable dentures*:

- *Part 1: Materials for short-term use*
- *Part 2: Materials for long-term use*

Introduction

Clinically, short-term denture-lining materials are used commonly as tissue conditioners and as temporary soft lining materials. It is believed that their use as functional impression materials is now less common. Therefore, the tests are designed to cover the more common usages.

It is recognized that the short-term material, when used as a tissue conditioner, is commonly changed every few days with the aim of returning the mucosa to a healthy condition as quickly as possible. As a temporary soft lining, the material is commonly placed in immediate dentures and in dentures that need to be modified as part of implant treatment. Therefore the specification has been so designed to necessitate that a material exhibit the required properties over a 7-d period. It is of course recognized that there are a number of clinical situations where it is appropriate to retain the soft lining in the denture for periods longer than 7 d. It is also recognized that manufacturers may wish to provide more than one set of times, temperatures, proportions and procedures to mix or prepare the material properly in order that the material can satisfy the requirements of more than one type or class.

In its earliest stage, the soft lining material is usually removed from the mouth so that it can be adjusted and tidied. If the material attains a particular level of elastic recovery, removal from the mouth will not result in unacceptable distortion. Therefore, denture lining materials for short-term use are classified in this part of ISO 10139 according to the time at which 10 % elastic recovery is established. (When stating the time at which 10 % elastic recovery is established, the manufacturer is to take, as zero time, the end of mixing.)

The other classification is related to initial compliance.

Although it is not claimed that any particular time at which 10 % elastic recovery is attained or level of compliance is superior to another, these classifications are intended to assist clinicians who will now have more information with which to make an informed choice.

In an attempt to establish some degree of harmony with the procedures used to evaluate related dental materials, the displacement rheometer, which is used to measure the setting characteristics of elastomeric impression materials, has been adopted to measure elastic recovery of the short-term soft lining materials (ISO 4823:2000). This method supersedes the consistency test.

This part of ISO 10139 does not include specific qualitative and quantitative requirements for freedom from biological hazard. When possible biological or toxicological hazards need to be assessed, refer to ISO 7405 (see the Bibliography).

Dentistry — Soft lining materials for removable dentures —

Part 1: Materials for short-term use

1 Scope

This part of ISO 10139 specifies requirements for the physical properties, test methods, packaging, marking and manufacturer's instructions for denture lining materials suitable for short-term use.

2 Normative references

The following referenced documents are indispensable for the application of this document. For dated references, only the edition cited applies. For undated references, the latest edition of the referenced document (including any amendments) applies.

ISO 3696, *Water for analytical laboratory use — Specification and test methods*

3 Terms and definitions

For the purposes of this document, the following terms and definitions apply.

3.1

tissue conditioning material

soft lining material, placed in the fitting surface of a denture, that is intended to be in contact with the denture-supporting mucosa, commonly for a period of up to 7 d, with the aim of assisting its return to a healthy condition

3.2

temporary soft lining material for dentures

soft lining material for dentures that is intended to be used for a limited period to improve fit, retention and comfort

4 Classification

4.1 Types

Materials for short-term use shall be classified into the following types according to development of elastic recovery (see 5.1) as determined in accordance with 7.2:

- Type A: allows short time before removal from the mouth (5 min or less than 5 min);
- Type B: allows extended time before removal from the mouth (more than 5 min).

4.2 Classes

The materials shall be further subdivided into classes according to their initial compliance as measured by initial resistance to indentation (see 5.2) determined in accordance with 7.3:

- Class 1: high initial compliance;
- Class 2: low initial compliance.

5 Requirements

5.1 Development of elastic recovery

When specimens are subjected to the displacement rheometer test in accordance with 7.2, two of the three specimens of the material shall conform to the requirement for the relevant type as shown in Table 1. If only one specimen meets the requirement, the material shall be deemed not to conform to this part of ISO 10139.

Table 1 — Development of elastic recovery

Type	Time at which 10 % recovery is attained at test carried out at 37 °C
	<i>t</i> min
A	$t \leq 5$
B	$t > 5$

5.2 Change in compliance with age as measured by depth of penetration

5.2.1 Depth of penetration at 2 h

When 2-h old test specimens are subjected to the depth of penetration test in accordance with 7.3, two of the three specimens of the material shall conform to the requirements of the particular class as shown in Table 2. If only one specimen meets the requirement, the material shall be deemed not to conform to this part of ISO 10139.

Table 2 — Depth of penetration

Class	Depth of penetration at 2 h
	mm
1	$\geq 1,5$
2	$< 1,5$

5.2.2 Depth of penetration at 7 d

The depth of penetration at 7 d shall be no less than 0,5 mm. If only one specimen meets this requirement the material shall be deemed not to conform to this part of ISO 10139.

6 Sampling

The test sample shall consist of a retail package, or packages, from the same batch.

7 Test methods

7.1 Ambient conditions for testing

All tests shall be conducted at (23 ± 1) °C unless otherwise stated.

7.2 Measurement of elastic recovery

7.2.1 Apparatus

7.2.1.1 Displacement rheometer (see Figure 1).

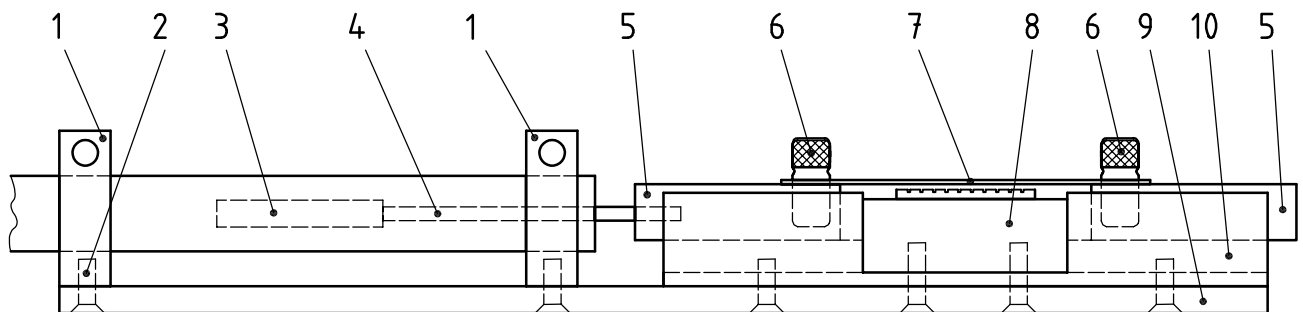

Key

1	LVDT support	6	plate aligning and locking pins
2	flat head assembly screws	7	perforated test plate
3	LVDT core	8	slotted test specimen pedestal
4	core carrier rod	9	instrument base
5	sliding polymer blocks	10	glide track

Figure 1 — Displacement rheometer

NOTE See ISO 4823:2000 for further figures which contain full details and dimensions of the displacement rheometer.

No lubricants shall be used in attempts to reduce friction between the bearing surfaces [(5) and (10) of Figure 1] of the test instrument.

Before using the instrument, the following procedure to determine whether the friction between bearing areas of the instrument is within acceptable limits shall be used.

- a) Detach the linear variable displacement transducer (LVDT) core carrier rod [(4) of Figure 1] from the sliding polymer blocks [(5) of Figure 1].
- b) Clean and dry the bearing surfaces and examine them for defects that can be detected by touch (burrs, nicks, etc). Eliminate any such defects.
- c) Seat the sliding blocks in the glide track [(10) of Figure 1], and use the perforated test plate [(7) of Figure 1] and the plate aligning and locking pins [(6) of Figure 1] to connect the parts for testing.
- d) Elevate one end of the instrument so that the base is at 20° to horizontal.

- e) Then, by hand, move the sliding block/perforated test plate assembly in the glide track to the upper extreme position and release it immediately. If the assembly moves freely to the lower extreme position under the pull of gravity, the friction is within acceptable limits.
- f) Repeat the preceding step with the opposite end of the instrument elevated to determine whether freedom of movement in the opposite direction is acceptable.
- g) Turn the perforated test plate [(7) of Figure 1] upside down and repeat steps e) and f). If the friction cannot be reduced to acceptable limits by removal of burrs, contaminates, etc. it may be necessary to resurface the bearing areas to eliminate binding interferences and check that the perforated test plate is not distorted.
- h) Upon achieving acceptable limits for friction, re-attach the core carrier rod.

7.2.1.2 Linear variable displacement transducer (LVDT), having a linear working range > 12,5 mm.

The transducer shall be passive, i.e. not spring-loaded.

7.2.1.3 Power supply (± 15 V d.c., regulated), for modulating the LVDT signals.

7.2.1.4 Recorder, compatible with the LVDT and associated equipment.

7.2.1.5 Water bath, capable of maintaining the upper surface of the slotted specimen pedestal [(8) of Figure 1] at (37 ± 1) °C.

7.2.1.6 Instrument for measuring temperature, of the upper surface of the slotted specimen pedestal [(8) of Figure 1].

7.2.1.7 Timing device, accurate to $\pm 0,1$ s.

7.2.2 Instrumentation assembly and adjustment

Connect the LVDT (7.2.1.2) to the recorder (7.2.1.4) through the power supply (7.2.1.3).

Adjust the LVDT body position, as required, to establish a body/core relationship whereby a full scale deflection of the recorder pen will indicate a rheometer displacement of 3,5 mm.

Confirm that the recorder pen reflects a linear function of the rheometer displacement.

7.2.3 Preparation of test specimens

Each specimen shall be prepared in accordance with the manufacturer's instructions and at ambient temperature (7.1).

If the manufacturer provides more than one set of instructions each additional set shall be subjected to the test procedure.

NOTE Manufacturers may wish to provide more than one set of times, temperatures, proportions and procedures to mix or prepare the material properly in order that the material can satisfy the requirements of more than one type or class.

7.2.4 Test procedure

Start the timing device (7.2.1.7) on completion of the mix. At 60 s, deposit an increment of about 2 ml of the material in the centre of the top surface of the slotted test specimen pedestal [(8) of Figure 1]. Force the perforated test plate [(7) of Figure 1] into the material, until the underside of both ends of the plate contact the upper surfaces of the sliding polymer blocks [(5) of Figure 1] and so that the material extrudes through at least 28 of the perforations.

Align the locking pin holes in the perforated test plate with the pin holes in the sliding blocks, and insert the locking pins [(6) of Figure 1] to secure the parts prior to testing.

The temperature of the water flowing through the slotted specimen pedestal should be such that a temperature of (37 ± 1) °C is recorded on the top surface of the pedestal.

Zero the chart recorder pen before activating the recorder chart drive to begin the test schedule described below. At 1 min before the time recommended by the manufacturer as being the earliest safe removal time (see Introduction for explanation), use finger pressure against the sliding polymer block [(5) of Figure 1] so as to displace the sliding block/perforated plate assembly by 0,25 mm, as reflected by the recorder tracing. Remove the finger pressure 5 s after completing the displacement and observe the behaviour of the recorder trace.

NOTE An alternative to displacing the sliding block/perforated plate manually is to apply a force to the end of sliding polymer blocks [(5) of Figure 1] through a modified measuring instrument such as a micrometer.

Repeat the displacement procedure every 30 s.

Record the time at which the test specimen first exhibits an elastic recovery of 10 %.

Carry out the above test procedure on each of three test specimens.

7.3 Test of compliance as measured by depth of penetration

7.3.1 Apparatus

7.3.1.1 Penetrometer instrument, as shown in Figure 2, equipped with a cylindrical penetrator (1), 1 mm in diameter, which is fixed on a vertical rod (3).

The vertical rod plus the cylindrical penetrator shall have a total mass of (50 ± 5) g. The penetrometer shall have a locking device (4) that permits fixing the penetrator at any vertical position and a means of measuring the depth of penetration.

The dial gauge (2) shall be capable of measuring to 0,1 mm.

7.3.1.2 Three beakers, of 100 ml capacity.

7.3.1.3 Water bath, capable of being maintained at (37 ± 1) °C and large enough to carry three 100 ml beakers (7.3.1.2).

7.3.1.4 Flat plate, having dimensions of (50 ± 5) mm \times (50 ± 5) mm \times $(4 \pm 0,5)$ mm made of unplasticized poly(methyl methacrylate) (PMMA), such as Plexiglas or Perspex¹⁾.

1) Plexiglas and Perspex are trademarks. This information is given for the convenience of users of this International Standard and does not constitute an endorsement by ISO of the products named. Equivalent products may be used if they can be shown to lead to the same results.

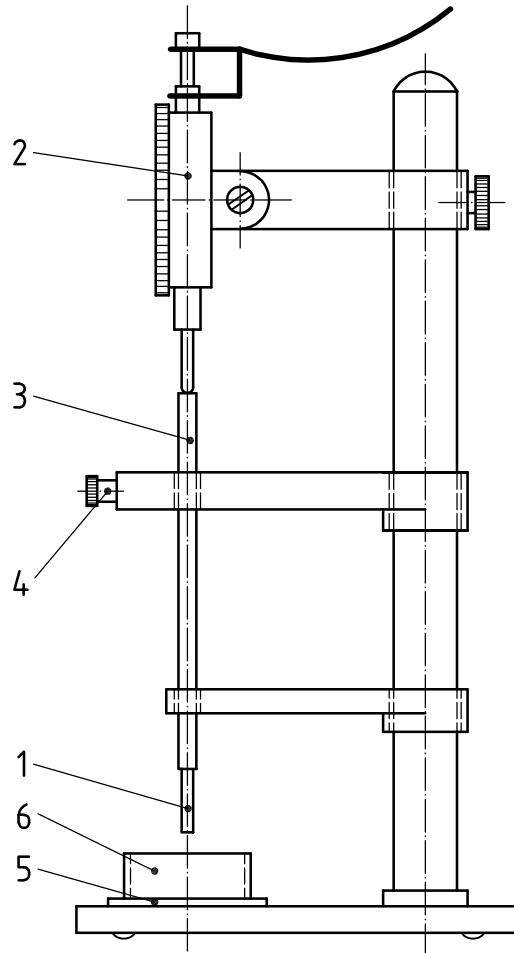

Key

- 1 cylindrical penetrator
- 2 dial indicator (gauge)
- 3 vertical rod
- 4 locking device
- 5 PMMA plate
- 6 metal ring

Figure 2 — Penetrometer

7.3.1.5 Metal ring, having a (30 ± 1) mm internal diameter and $(3 \pm 0,1)$ mm high, see Figure 3.

The metal ring is non-reactive or can be made non-reactive to soft lining material. All penetration points are at least 5 mm inside the metal ring and are at least 5 mm from each other. Each A (or B) penetration point is $120^\circ \pm 2^\circ$ from another A (or B) penetration point.

7.3.1.6 Unplasticized polyester film, or other suitable material that does not affect the physical properties of the short-term soft lining material, of (50 ± 30) μm thickness.

Dimensions in millimetres

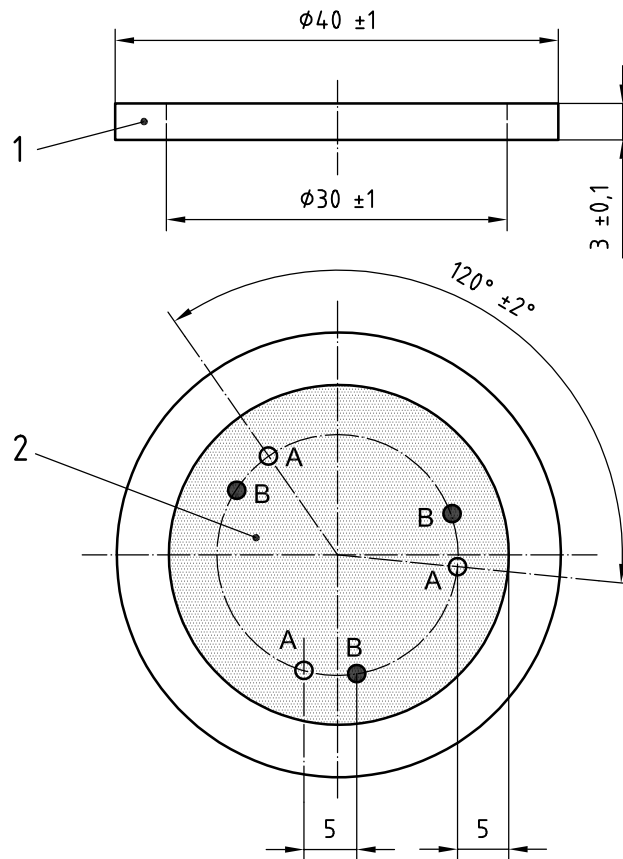
**Key**

- 1 metal ring
- 2 soft lining material
- A penetration points at 2 h
- B penetration points at 7 d

Figure 3 — Metal ring for penetration test

7.3.1.7 Glass plate, having dimensions of (50 ± 5) mm \times (50 ± 5) mm \times $(6 \pm 0,5)$ mm.

7.3.1.8 Weight piece, weighing $(2 \pm 0,1)$ kg.

7.3.1.9 Timing device, accurate to $\pm 0,1$ s.

7.3.2 Reagents

7.3.2.1 Water, conforming to the requirements in ISO 3696 or similar.

7.3.3 Procedure

Prepare a sample of approximately 20 ml according to the manufacturer's instructions at ambient temperature (see 7.1).

If the manufacturer provides more than one set of instructions each additional set shall be subjected to the test procedure. (See Note to 7.2.3.)

Place the metal ring (7.3.1.5) on the PMMA plate (7.3.1.4) and fill it to a slight excess with the mixed material. Cover the material with the polyester film (7.3.1.6). Place the glass plate (7.3.1.7) on top and apply the weight piece (7.3.1.8). Ten minutes after the start of mixing, remove the load and the glass plate. Place the sample in a 100 ml beaker (7.3.1.2) of water (7.3.2.1) at $(37 \pm 1) ^\circ\text{C}$, ensuring that the water covers the sample. Store the beaker in the water bath (7.3.1.3) at $(37 \pm 1) ^\circ\text{C}$.

Remove the specimen from the water bath 118 min after the start of mixing and return it to ambient conditions. Remove the polyester film. Place the specimen under the penetrometer instrument (7.3.1.1) and bring the cylindrical penetrator [(1) of Figure 2] just into contact with the surface of the specimen and lock in position. Bring the rod from the dial gauge [(2) of Figure 2] into contact with the vertical rod [(3) of Figure 2] and adjust the dial gauge to zero. Ensure that the dial gauge is removed from the rod before loading the specimen.

Release the vertical rod for $(3 \pm 0,1) \text{ s}$ 120 min after the start of the mixing, allowing the penetrator to penetrate the specimen and lock it in position. Bring the rod of the dial indicator into contact with the adjusted vertical rod again, and record the depth of penetration in millimetres. Bring the cylindrical penetrator into contact with a new area on the specimen and repeat this test at 120,5 min and 121 min. Record the mean of the three measurements (see Table 2).

Store the specimen again in water at $(37 \pm 1) ^\circ\text{C}$. Repeat the test after 7 d. Carry out the first penetration at 2 min following removal from the water bath. Record the mean of the three measurements (see 5.2.2).

If the design of the apparatus allows the depth of penetration and time characteristics to be recorded, it is permissible to take the measurements directly from the time–distance curve.

Test three samples with three readings (penetrations) from each sample. Ensure that each penetration is at least 5 mm from the ring and from each of the other penetrations. Locate the three penetration points on the perimeter of $(20 \pm 1) \text{ mm}$ diameter circle $(120 \pm 2)^\circ$ apart.

Figure 3 shows the location of the areas where the penetrator is to be placed.

8 Requirement for labelling, marking and instructions supplied by the manufacturer

8.1 Packaging

The components shall be supplied in sealed containers made of materials that shall neither contaminate, nor permit contamination, of the contents. The immediate containers shall be packaged so as to prevent damage or leakage during transit and storage.

An outer package may also be used to present the containers as a single unit.

8.2 Marking

The outer packages and the immediate containers or wrappings of the components shall be clearly marked with the following information:

- a) the trade name of the product;
- b) the manufacturer's name or trademark and address, or those of the agent in the country of sale;
- c) the description of the contents including the following:
 - 1) the type and class of material, as determined in accordance with Clause 7,
 - 2) the number of this part of ISO 10139, i.e. ISO 10139-1,
 - 3) the chemical nature of the system, for example plasticized acrylics, silicones,
 - 4) a statement that the product is a soft lining material for short-term use in removable dentures;

- d) the net content of the components expressed in grams for solids and millilitres for liquids;
- e) the lot number (batch code);
- f) the expiry date beyond which the material might not exhibit its required properties (year, month);
- g) the recommended conditions of storage;
- h) any hazard warnings, where appropriate, for toxic, hazardous, inflammable or irritating characteristics and flash point of liquid;
- i) any pharmaceutically active ingredients present and referred to in the material claim or use.

In those cases where the size of the immediate container or package is too small to fit in all the details, reference shall be made on the outer package to a leaflet inside where the additional information shall be provided.

8.3 Manufacturer's instructions for use

Instructions for use shall accompany each package and, at minimum, shall include the following information:

- a) the information listed in 8.2 with the exception of the information in 8.2 e);
- b) the fields of application;
- c) the contraindications, side-effects and interactions with other substances, if appropriate;
- d) the time, temperature, proportions and procedure to mix or prepare the material properly;
- e) information on the care of the lined denture by the patient and recommendations for cleaning, including reference to any method or material which would be inappropriate for cleaning the lining;
- f) information on the disinfecting of the lined denture by the dentist or dental technician in order to minimize the possibility of cross-infection; include reference to any method or material that would be inappropriate;
- g) any information on environmental conditions that may adversely affect the material, such as temperature, humidity or ambient light, and the disposal of waste, if precautions are necessary.

Bibliography

- [1] ISO 4823:2000, *Dentistry — Elastomeric impression materials*
- [2] ISO 7405, *Dentistry — Preclinical evaluation of biocompatibility of medical devices used in dentistry — Test methods for dental materials*

BSI — British Standards Institution

BSI is the independent national body responsible for preparing British Standards. It presents the UK view on standards in Europe and at the international level. It is incorporated by Royal Charter.

Revisions

British Standards are updated by amendment or revision. Users of British Standards should make sure that they possess the latest amendments or editions.

It is the constant aim of BSI to improve the quality of our products and services. We would be grateful if anyone finding an inaccuracy or ambiguity while using this British Standard would inform the Secretary of the technical committee responsible, the identity of which can be found on the inside front cover.
Tel: +44 (0)20 8996 9000. Fax: +44 (0)20 8996 7400.

BSI offers members an individual updating service called PLUS which ensures that subscribers automatically receive the latest editions of standards.

Buying standards

Orders for all BSI, international and foreign standards publications should be addressed to Customer Services. Tel: +44 (0)20 8996 9001.
Fax: +44 (0)20 8996 7001. Email: orders@bsi-global.com. Standards are also available from the BSI website at <http://www.bsi-global.com>.

In response to orders for international standards, it is BSI policy to supply the BSI implementation of those that have been published as British Standards, unless otherwise requested.

Information on standards

BSI provides a wide range of information on national, European and international standards through its Library and its Technical Help to Exporters Service. Various BSI electronic information services are also available which give details on all its products and services. Contact the Information Centre.
Tel: +44 (0)20 8996 7111. Fax: +44 (0)20 8996 7048. Email: info@bsi-global.com.

Subscribing members of BSI are kept up to date with standards developments and receive substantial discounts on the purchase price of standards. For details of these and other benefits contact Membership Administration.
Tel: +44 (0)20 8996 7002. Fax: +44 (0)20 8996 7001.
Email: membership@bsi-global.com.

Information regarding online access to British Standards via British Standards Online can be found at <http://www.bsi-global.com/bsonline>.

Further information about BSI is available on the BSI website at <http://www.bsi-global.com>.

Copyright

Copyright subsists in all BSI publications. BSI also holds the copyright, in the UK, of the publications of the international standardization bodies. Except as permitted under the Copyright, Designs and Patents Act 1988 no extract may be reproduced, stored in a retrieval system or transmitted in any form or by any means – electronic, photocopying, recording or otherwise – without prior written permission from BSI.

This does not preclude the free use, in the course of implementing the standard, of necessary details such as symbols, and size, type or grade designations. If these details are to be used for any other purpose than implementation then the prior written permission of BSI must be obtained.

Details and advice can be obtained from the Copyright & Licensing Manager.
Tel: +44 (0)20 8996 7070. Fax: +44 (0)20 8996 7553.
Email: copyright@bsi-global.com.