

BS EN ISO 9934-1:2016



BSI Standards Publication

Non-destructive testing — Magnetic particle testing

Part 1: General principles
(ISO 9934-1:2016)

bsi.

National foreword

This British Standard is the UK implementation of EN ISO 9934-1:2016. It supersedes BS EN ISO 9934-1:2015 which is withdrawn.

The UK participation in its preparation was entrusted to Technical Committee WEE/46, Non-destructive testing.

A list of organizations represented on this committee can be obtained on request to its secretary.

This publication does not purport to include all the necessary provisions of a contract. Users are responsible for its correct application.

© The British Standards Institution 2016.
Published by BSI Standards Limited 2016

ISBN 978 0 580 93987 7

ICS 19.100

Compliance with a British Standard cannot confer immunity from legal obligations.

This British Standard was published under the authority of the Standards Policy and Strategy Committee on 31 December 2016.

Amendments/corrigenda issued since publication

Date	Text affected
------	---------------

EUROPEAN STANDARD

EN ISO 9934-1

NORME EUROPÉENNE

EUROPÄISCHE NORM

December 2016

ICS 19.100

Supersedes EN ISO 9934-1:2015

English Version

**Non-destructive testing - Magnetic particle testing - Part 1:
General principles (ISO 9934-1:2016)**Essais non destructifs - Magnétoscopie - Partie 1:
Principes généraux du contrôle (ISO 9934-1:2016)Zerstörungsfreie Prüfung - Magnetpulverprüfung - Teil
1: Allgemeine Grundlagen (ISO 9934-1:2016)

This European Standard was approved by CEN on 21 October 2016.

CEN members are bound to comply with the CEN/CENELEC Internal Regulations which stipulate the conditions for giving this European Standard the status of a national standard without any alteration. Up-to-date lists and bibliographical references concerning such national standards may be obtained on application to the CEN-CENELEC Management Centre or to any CEN member.

This European Standard exists in three official versions (English, French, German). A version in any other language made by translation under the responsibility of a CEN member into its own language and notified to the CEN-CENELEC Management Centre has the same status as the official versions.

CEN members are the national standards bodies of Austria, Belgium, Bulgaria, Croatia, Cyprus, Czech Republic, Denmark, Estonia, Finland, Former Yugoslav Republic of Macedonia, France, Germany, Greece, Hungary, Iceland, Ireland, Italy, Latvia, Lithuania, Luxembourg, Malta, Netherlands, Norway, Poland, Portugal, Romania, Slovakia, Slovenia, Spain, Sweden, Switzerland, Turkey and United Kingdom.

EUROPEAN COMMITTEE FOR STANDARDIZATION
COMITÉ EUROPÉEN DE NORMALISATION
EUROPÄISCHES KOMITEE FÜR NORMUNG**CEN-CENELEC Management Centre: Avenue Marnix 17, B-1000 Brussels**

Contents	Page
European foreword.....	3

European foreword

This document (EN ISO 9934-1:2016) has been prepared by Technical Committee ISO/TC 135 "Non-destructive testing" in collaboration with Technical Committee CEN/TC 138 "Non-destructive testing" the secretariat of which is held by AFNOR.

This European Standard shall be given the status of a national standard, either by publication of an identical text or by endorsement, at the latest by June 2017, and conflicting national standards shall be withdrawn at the latest by June 2017.

Attention is drawn to the possibility that some of the elements of this document may be the subject of patent rights. CEN [and/or CENELEC] shall not be held responsible for identifying any or all such patent rights.

This document supersedes EN ISO 9934-1:2015.

According to the CEN-CENELEC Internal Regulations, the national standards organizations of the following countries are bound to implement this European Standard: Austria, Belgium, Bulgaria, Croatia, Cyprus, Czech Republic, Denmark, Estonia, Finland, Former Yugoslav Republic of Macedonia, France, Germany, Greece, Hungary, Iceland, Ireland, Italy, Latvia, Lithuania, Luxembourg, Malta, Netherlands, Norway, Poland, Portugal, Romania, Slovakia, Slovenia, Spain, Sweden, Switzerland, Turkey and the United Kingdom.

Endorsement notice

The text of ISO 9934-1:2016 has been approved by CEN as EN ISO 9934-1:2016 without any modification.

Contents

Page

Foreword	iv
1 Scope	1
2 Normative references	1
3 Terms and definitions	1
4 Qualification and certification of personnel	2
5 Safety and environment	2
6 Testing procedure	2
7 Surface preparation	2
8 Magnetization	2
8.1 General requirements	2
8.2 Verification of magnetization	3
8.3 Magnetizing techniques	4
8.3.1 General	4
8.3.2 Current flow techniques	4
8.3.3 Magnetic flow techniques	6
9 Detection media	10
9.1 Properties and selection of media	10
9.2 Testing of detection media	10
9.3 Application of detection media	10
10 Viewing conditions	10
11 Overall performance test	10
12 Interpretation and recording of indications	11
13 Demagnetization	11
14 Cleaning	11
15 Test report	12
Annex A (informative) Example for determination of currents required to achieve specified tangential field strengths for various magnetization techniques	13
Bibliography	17

Foreword

ISO (the International Organization for Standardization) is a worldwide federation of national standards bodies (ISO member bodies). The work of preparing International Standards is normally carried out through ISO technical committees. Each member body interested in a subject for which a technical committee has been established has the right to be represented on that committee. International organizations, governmental and non-governmental, in liaison with ISO, also take part in the work. ISO collaborates closely with the International Electrotechnical Commission (IEC) on all matters of electrotechnical standardization.

The procedures used to develop this document and those intended for its further maintenance are described in the ISO/IEC Directives, Part 1. In particular the different approval criteria needed for the different types of ISO documents should be noted. This document was drafted in accordance with the editorial rules of the ISO/IEC Directives, Part 2 (see www.iso.org/directives).

Attention is drawn to the possibility that some of the elements of this document may be the subject of patent rights. ISO shall not be held responsible for identifying any or all such patent rights. Details of any patent rights identified during the development of the document will be in the Introduction and/or on the ISO list of patent declarations received (see www.iso.org/patents).

Any trade name used in this document is information given for the convenience of users and does not constitute an endorsement.

For an explanation on the meaning of ISO specific terms and expressions related to conformity assessment, as well as information about ISO's adherence to the World Trade Organization (WTO) principles in the Technical Barriers to Trade (TBT) see the following URL: www.iso.org/iso/foreword.html.

The committee responsible for this document is ISO/TC 135, *Non-destructive testing*, Subcommittee SC 2, *Surface methods*.

This third edition cancels and replaces the second edition (ISO 9934-1:2015), of which it constitutes a minor revision, with the modification for clarity of Clause 13 and other editorial improvements.

A list of all parts in the ISO 9934 series, published under the general title *Non-destructive testing — Magnetic particle testing*, can be found on the ISO website.

Non-destructive testing — Magnetic particle testing —

Part 1: General principles

1 Scope

This document specifies general principles for the magnetic particle testing of ferromagnetic materials. Magnetic particle testing is primarily applicable to the detection of surface-breaking discontinuities, particularly cracks. It can also detect discontinuities just below the surface but its sensitivity diminishes rapidly with depth.

This document specifies the surface preparation of the part to be tested, magnetization techniques, requirements and application of the detection media, and the recording and interpretation of results. Acceptance criteria are not defined. Additional requirements for the magnetic particle testing of particular items are defined in product standards (see the relevant International Standards or European standards).

This document does not apply to the residual magnetization method.

2 Normative references

The following documents are referred to in the text in such a way that some or all of their content constitutes requirements of this document. For dated references, only the edition cited applies. For undated references, the latest edition of the referenced document (including any amendments) applies.

ISO 3059, *Non-destructive testing — Penetrant testing and magnetic particle testing — Viewing conditions*

ISO 9934-2, *Non-destructive testing — Magnetic particle testing — Part 2: Detection media*

ISO 9934-3, *Non-destructive testing — Magnetic particle testing — Part 3: Equipment*

ISO 12707, *Non-destructive testing — Magnetic particle testing — Vocabulary*

EN 1330-1, *Non-destructive testing — Terminology — Part 1: General terms*

EN 1330-2, *Non-destructive testing — Terminology — Part 2: Terms common to non-destructive testing methods*

3 Terms and definitions

For the purposes of this document, the terms and definitions given in ISO 12707, EN 1330-1 and EN 1330-2 apply.

ISO and IEC maintain terminological databases for use in standardization at the following addresses:

- IEC Electropedia: available at <http://www.electropedia.org/>
- ISO Online browsing platform: available at <http://www.iso.org/obp>

4 Qualification and certification of personnel

It is assumed that magnetic particle testing is performed by qualified and capable personnel. In order to provide this qualification, it is recommended to certify the personnel in accordance with ISO 9712 or equivalent.

5 Safety and environment

International, regional, national and/or local regulations which include health, safety and environment may exist and may need to be taken into account.

Magnetic particle testing often creates high magnetic fields close to the object under test and the magnetizing equipment. Items sensitive to these fields should be excluded from such areas.

6 Testing procedure

When required at the time of enquiry and order, magnetic particle testing shall be performed in accordance with a written procedure.

The procedure can take the form of a brief technique sheet, containing a reference to this and other appropriate standards. The procedure should specify testing parameters in sufficient detail for the test to be repeatable.

All testing shall be performed in accordance with an approved written procedure or the relevant product standard shall be referenced

7 Surface preparation

Areas to be tested shall be free from dirt, scale, loose rust, weld spatter, grease, oil, and any other foreign materials that can affect the test sensitivity.

The surface quality requirements are dependent upon the size and orientation of the discontinuity to be detected. The surface shall be prepared so that relevant indications can be clearly distinguished from false indications.

Non-ferromagnetic coatings up to approximately 50 μm thickness, such as unbroken adherent paint layers, do not normally impair detection sensitivity. Thicker coatings reduce sensitivity. Under these conditions, the sensitivity shall be verified.

There shall be a sufficient visual contrast between the indications and the test surface. For the non-fluorescent technique, it might be necessary to apply a uniform, thin, temporarily adherent layer of approved contrast aid paint.

8 Magnetization

8.1 General requirements

The minimum magnetic flux density (B) regarded as adequate for testing is 1 T. The applied magnetic field (H) required to achieve this in low-alloy and low-carbon steels is determined by the relative permeability of the material. This varies according to the material, the temperatures, and also with the applied magnetic field and for these reasons, it is not possible to provide a definitive requirement for the applied magnetic field. However, typically a tangential field of approximately 2 kA/m will be required.

Where time varying currents (I) are used to produce a magnetic field (which will also be time varying), it is important to control the crest factor (shape) of the waveform and the method of measurement of the current in order to establish a repeatable technique. Both peak and RMS measurements are

typically used and measurement of the values can be affected by the response of the instrument. For this reason, only instruments that respond directly to the waveform shall be used (e.g. true RMS meters with appropriate crest factor capability for accurate RMS measurements). Instruments that calculate peak or RMS values based on theoretical calculation derived from other values shall not be used. This shall also apply to instruments used to measure magnetic fields

Smooth shaped waveforms provide low crest factors and least variation between peak and true RMS values and are regarded as preferable for magnetic particle testing. Waveforms with a crest factor (i.e. I_{pk}/I_{RMS}) greater than 3 shall not be used without documented evidence of the effectiveness of the technique.

When using multidirectional magnetization techniques, the current used shall be purely sinusoidal or phase controlled but the phase cutting shall not be more than 90°. Practical demonstration that the technique is effective in all directions shall be carried out (e.g. using sample parts with known defects or shim type indicators).

Provided the permeability is in the normal range and the current measurement methods are controlled as described, calculations based on the use of 2 kA/m can provide a valuable method of technique preparation. The use of either peak current or true RMS current is acceptable if the crest factor is known. Knowing the entire waveform of the magnetizing curve would be optimal, but knowing the crest factor is a good practical approximation. For pure sinusoidal waveforms, the relationship between peak, mean, and RMS is shown in [Annex A](#). Techniques based on calculation shall be verified before implementation.

NOTE 1 For steels, with low relative permeability, a higher tangential field strength might be necessary. If magnetization is too high, spurious background indications can appear, which could mask relevant indications.

If cracks or other linear discontinuities are likely to be aligned in a particular direction, the magnetic flux shall be aligned perpendicular to this direction where possible.

NOTE 2 The flux can be regarded as effective in detecting discontinuities aligned up to 60° from the optimum direction. Full coverage can then be achieved by magnetizing the surface in two perpendicular directions.

Magnetic particle testing should be regarded as a surface NDT method; however, discontinuities close to the surface can also be detected. For time varying waveforms, the depth of magnetization (skin depth) will depend on the frequency of the current waveform. Magnetic leakage fields produced by imperfections below the surface will fall rapidly with distance. Therefore, although magnetic particle testing is not recommended for the detection of imperfections other than on the surface, it can be noted that the use of smooth DC or rectified waveforms can improve detection of imperfections just below the surface.

8.2 Verification of magnetization

The adequacy of the surface flux density shall be established by one or more of the following methods:

- a) by testing a representative component containing fine natural or artificial discontinuities in the least favourable locations;
- b) by measuring the tangential field strength as close as possible to the surface (information on this is given in ISO 9934-3);
- c) by calculating the tangential field strength for current flow methods — simple calculations are possible in many cases, and they form the basis for current values specified in [Annex A](#);
- d) by the use of other methods based on established principles.

Flux indicators (e.g. shim-type), placed in contact with the surface under test, provide a guide to the magnitude and direction of the tangential field strength, but should not be used to verify that the tangential field strength is acceptable.

8.3 Magnetizing techniques

8.3.1 General

This subclause describes a range of magnetization techniques. Multi-directional magnetization can be used to find discontinuities in any direction. In the case of simple-shaped objects, formulae are given in [Annex A](#) for achieving approximate tangential field strengths. Magnetizing equipment shall meet the requirements of and be used in accordance with ISO 9934-3.

Magnetizing techniques are described in the following subclauses.

More than one technique might be necessary to find discontinuities on all test surfaces and in all orientations. Demagnetization might be required where the residual field from the first magnetization cannot be overcome. Techniques other than those listed can be used provided they give adequate magnetization, in accordance with [8.1](#).

8.3.2 Current flow techniques

8.3.2.1 Axial current flow

Current flow offers high sensitivity for detection of discontinuities parallel to the direction of the current.

Current passes through the component, which shall be in good electrical contact with the pads. A typical arrangement is shown in [Figure 1](#). The current is assumed to be distributed evenly over the surface and shall be derived from the peripheral dimensions. An example of approximate formula for the current required to achieve a specified tangential field strength is given in [Annex A](#).

Care shall be taken to avoid damage to the component at the point of electrical contacts. Possible hazards include excessive heat, burning, and arcing.

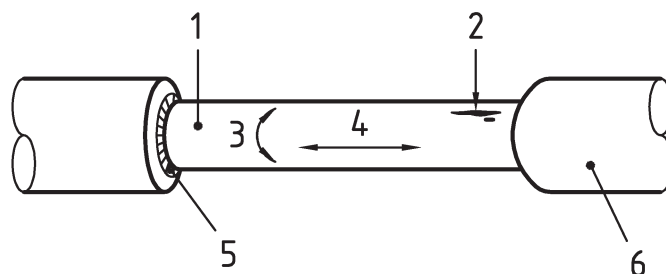

Key

1	specimen	4	current
2	flaw	5	contact pad
3	flux density	6	contact head

Figure 1 — Axial current flow

8.3.2.2 Prods; Current flow

Current is passed between hand-held or clamped contact prods as shown in [Figure 2](#), providing an inspection of a small area of a larger surface. The prods are then moved in a prescribed pattern to cover the required total area. Examples of testing patterns are shown in [Figures 2](#) and [3](#). Approximate formulae for the current required to achieve a specified tangential field strength are given in [Annex A](#).

This technique offers the highest sensitivity for discontinuities elongated parallel to the direction of the current. Particular care shall be taken to avoid surface damage due to burning or contamination of the component by the prods. Arcing or excessive heating shall be regarded as a defect requiring a verdict

on acceptability. If further testing is required on such affected areas, it shall be carried out using a different technique.

Dimensions in millimetres

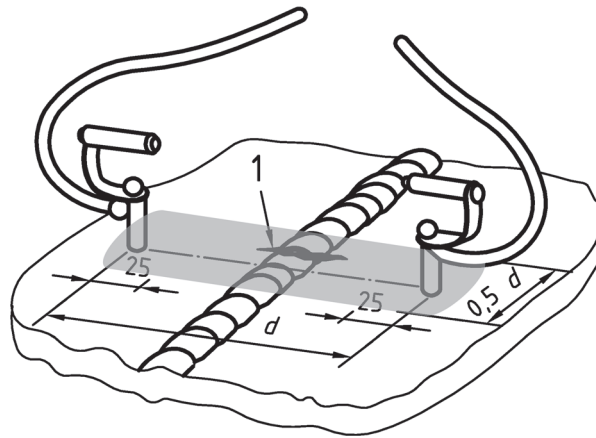

Key

1 flaw

Figure 2 — Prods; Current flow

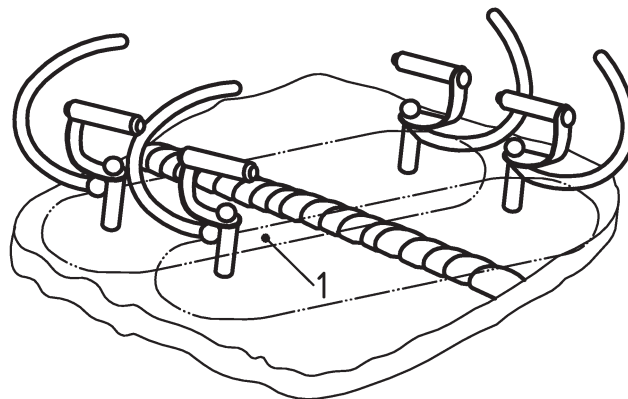

Key

1 overlap

Figure 3 — Prods; Current flow

8.3.2.3 Induced current flow

Current is induced in a ring shaped component by making it, in effect, the secondary of a transformer, as shown in [Figure 4](#). An example of an approximate formula for the induced current required to achieve a specified tangential field strength is given in [Annex A](#).

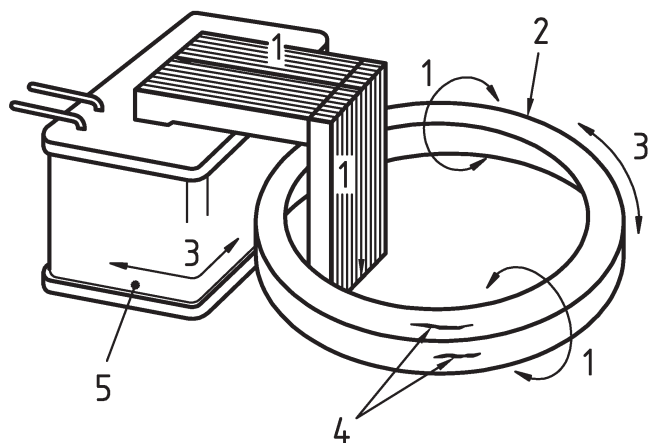

Key

- | | |
|------------|----------------------------|
| 1 flux | 4 flaw |
| 2 specimen | 5 transformer primary coil |
| 3 current | |

Figure 4 — Induced current flow

8.3.3 Magnetic flow techniques

8.3.3.1 Threading conductor

Current is passed through an insulated bar or flexible cable, placed within the bore of a component or through an aperture, as shown in [Figure 5](#).

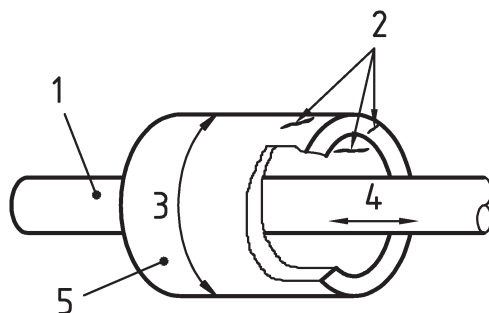

Key

- | | |
|---------------------------|------------|
| 1 insulated threading bar | 4 current |
| 2 flaws | 5 specimen |
| 3 flux density | |

Figure 5 — Threading conductor

This method offers the highest sensitivity for discontinuities parallel to the direction of current flow. The example of approximate formula given in [Annex A](#) for a central conductor is also applicable in this case. For a non-central conductor, the tangential field strength shall be verified by measurement.

8.3.3.2 Adjacent conductor(s)

One or more insulated current-carrying cables or bars are laid parallel to the surface of the component, adjacent to the area to be tested and supported at a distance, d , above it, as shown in [Figures 6 and 7](#).

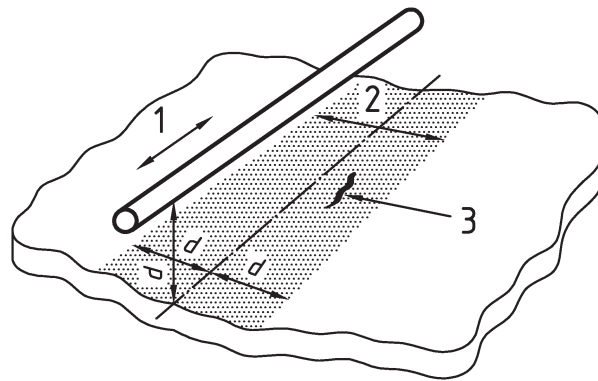

Key

- 1 current
- 2 flux density
- 3 flaw

Figure 6 — Adjacent conductor

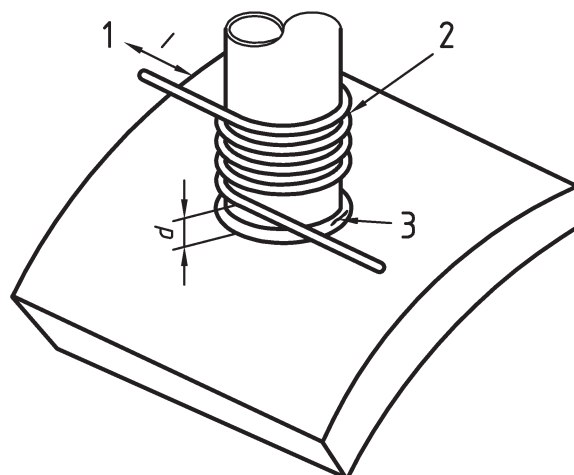

Key

- 1 current
- 2 n turns
- 3 flaw direction

Figure 7 — Adjacent cable (coiled)

The adjacent conductor technique of magnetization requires the material being tested to be in close proximity to a current flowing in one direction. The return cable for the electric current shall be arranged to be as far removed from the testing zone as possible and, in all cases, this distance shall be greater than $10 d$, where $2 d$ is the width of the tested area

The cable shall be moved over the component at intervals of less than $2 d$ to ensure that the inspection areas overlap. An example of an approximate formula for the current required to achieve a specified tangential field strength in the test zone is given in [Annex A](#).

8.3.3.3 Fixed installation

The component, or a portion of it, is placed in contact with the poles of an electromagnet, as shown in [Figure 8](#).

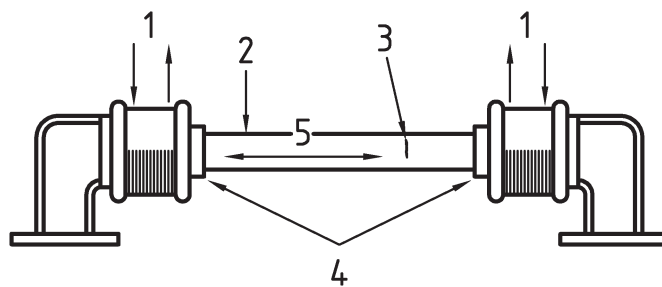

Key

- | | | | |
|---|----------|---|--------------|
| 1 | current | 4 | pole piece |
| 2 | specimen | 5 | flux density |
| 3 | flaw | | |

Figure 8 — Magnetic flow

8.3.3.4 Portable electromagnet (yoke)

The poles of an AC electromagnet (yoke) are placed in contact with the component surface as shown in [Figure 9](#). The testing area shall not be greater than that defined by a circle inscribed between the pole pieces and shall exclude the zone immediately adjacent to the poles. An example of a suitable testing area is shown in [Figure 9](#).

Dimension in millimetres

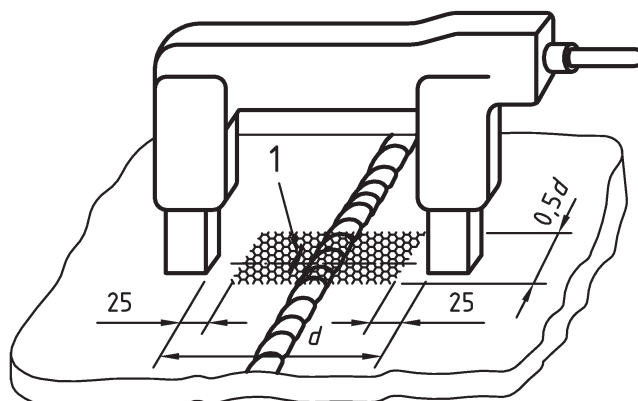

Key

- 1 flaw

Figure 9 — Portable electromagnet (yoke)

The magnetization requirements defined in [8.1](#) can only be met with AC electromagnets. DC electromagnets and permanent magnets may only be used by agreement at the time of enquiry and order.

8.3.3.5 Rigid coil

The component is placed within a current-carrying coil so that it is magnetized in the direction parallel to the axis of the coil, as shown in [Figure 10](#). Highest sensitivity is achieved for discontinuities elongated perpendicular to the coil axis.

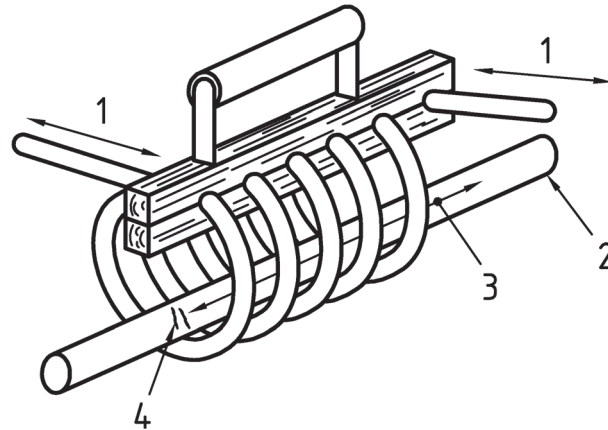

Key

- | | | | |
|---|----------|---|--------------|
| 1 | current | 3 | flux density |
| 2 | specimen | 4 | flaws |

Figure 10 — Rigid coil

When using rigid coils of a helical form, the pitch of the helix shall be less than 25 % of the coil diameter.

For short components, where the length to diameter ratio is less than 5, it is recommended that magnetic extenders be used. The current required to achieve the necessary magnetization is thus reduced.

An example of an approximate formula is given in [Annex A](#) for the current required to achieve a specified tangential field strength.

8.3.3.6 Flexible coil

A coil is formed by winding a current-carrying cable tightly around the component. The area to be tested shall lie between the turns of the coil, as shown in [Figure 11](#).

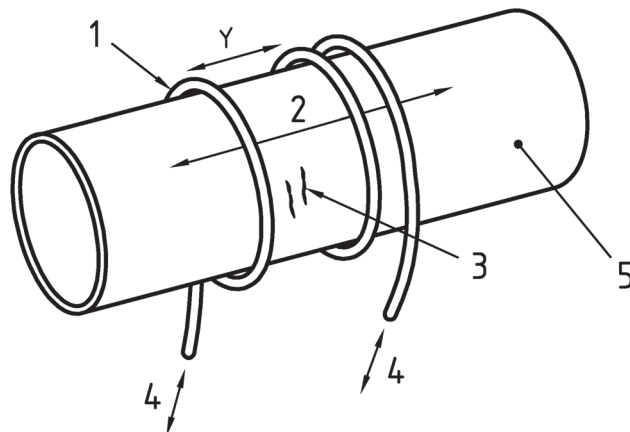

Key

- | | | | |
|---|-----------------|---|----------|
| 1 | insulated cable | 4 | current |
| 2 | flux density | 5 | specimen |
| 3 | flaws | | |

Figure 11 — Flexible coil

The [Annex A](#) gives approximate formulae for the current required to achieve a specified tangential field strength.

9 Detection media

9.1 Properties and selection of media

The characterization of detection media shall be in accordance with ISO 9934-2.

Various types of detection media exist in magnetic particle testing. Usually the detection media is a suspension of coloured (including black) or fluorescent magnetic particles in a carrier fluid. Water-based carriers shall contain wetting agents and usually a corrosion inhibitor.

Dry powders are also available. They are generally less able to reveal fine surface discontinuities.

Fluorescent detection media usually gives the highest sensitivity provided there is an appropriate surface finish, good drainage to maximize indication contrast, and well controlled viewing conditions, in accordance with [Clause 10](#).

Coloured detection media can also offer high sensitivity if the contrast with the part surface is sufficient. Black and other colours are available.

NOTE To achieve good colour contrast between discontinuities and the test surface, it might be necessary to apply a thin layer of contrast aid paint in accordance with [Clauses 7](#) and [10](#).

9.2 Testing of detection media

ISO 9934-2 defines mandatory and recommended tests that are to be carried out before or periodically during inspection.

A sensitivity check shall be carried out before and periodically during testing, in accordance with ISO 9934-2 using a suitable reference piece.

If a magnetic ink is re-used or re-circulated, particular care shall be taken to maintain its performance.

9.3 Application of detection media

For the continuous technique, the detecting media shall be applied immediately prior to and during the magnetization. The application shall cease before magnetization is terminated. Sufficient time shall be allowed for indications to develop before moving or examining the component or structure under test.

Dry powder, when used, shall be applied in a manner that minimizes disturbance of the indications.

During application of a magnetic ink, it shall be allowed to flow onto the surface with very little pressure so that the magnetic particles are allowed to form an indication without being washed off.

After applying a suspension, the component shall be allowed to drain so as to improve the contrast of any indications.

10 Viewing conditions

The viewing conditions shall meet the requirements of ISO 3059.

There shall be good contrast between the detection media and the test surface. Where viewing is obstructed, the component or equipment shall be moved to permit adequate viewing of all areas. Care shall be taken to ensure that indications are not disturbed after magnetization has stopped and before the component has been inspected and indications recorded.

11 Overall performance test

Before testing begins, an overall performance test shall be carried out to reveal discrepancies in either the procedure or the magnetization technique or the detection media.

The most reliable test is to inspect a representative part containing natural or artificial discontinuities of a known type, location, size, and size distribution. Test parts shall be demagnetized and free from indications resulting from previous tests.

In the absence of actual production parts with known discontinuities, fabricated test pieces with artificial discontinuities, e.g. flux shunting indicators of the cross or shim-type, can be used.

12 Interpretation and recording of indications

Care should be taken to differentiate between true indications and spurious or false indications, such as scratches, changes of section, boundary between regions of different magnetic properties, or magnetic writing. The operator shall carry out any necessary testing and observations to identify and, if possible, to eliminate the reason for such false indications.

NOTE Light surface dressing might be of value where permitted.

All indications which cannot be confidently discounted as false shall be classified as linear or rounded, in accordance with the following definition, and shall be recorded as required by the product standard.

Linear indications are those indications in which the length is more than three times the width. Rounded indications are indications that are circular or elliptical and where the length is less or equal to three times the width.

13 Demagnetization

When required at the time of enquiry and order, post-test demagnetization shall be carried out by an appropriate technique, in order to reduce the residual field strength to a level which is below the agreed maximum permitted value. If viewing for indications is carried out after demagnetization, indications shall be preserved by a suitable method.

There are occasional circumstances when demagnetization is necessary before testing is carried out. This is when the initial level of residual magnetism is such that adherent swarf, opposing flux or spurious indications could limit the effectiveness of the test.

Magnetic field remaining after magnetization can be determined by detecting the residual field strength using a residual field meter, a Hall effect instrument or by an agreed physical method (e.g. compass test). Generally, this will require moving the sensitive element all over the part and observing the maximum level. Care shall be taken when using Hall effect instruments (designed to measure tangential field strength) because these are not designed to provide accurate, quantitative measurement of fields perpendicular to a surface which may be encountered when checking for residual magnetization.

NOTE Demagnetization using an alternating field can be achieved by reducing the field strength from an initial value equal to, or greater than that used for magnetization.

A complete demagnetization is often very difficult to achieve, especially when the test object has been magnetized using DC. For components initially magnetized using DC techniques, low frequency or reversing DC demagnetization is to be used.

14 Cleaning

After testing and acceptance, if required, all components shall be cleaned to remove detecting media.

NOTE In addition, it might be necessary to protect the component against corrosion.

15 Test report

If a test report is required it shall include, as a minimum, the following information:

- a) name of the company;
- b) work location;
- c) description and identity of the part tested;
- d) stage of test (e.g. before or after heat treatment, before or after final machining);
- e) reference to standards, the written test procedure and the technique sheets used;
- f) description of equipment used;
- g) magnetization technique, including (as appropriate) indicated current values, tangential field strengths, waveform, contact or pole spacing, coil dimensions, etc.;
- h) detection media used, and contrast aid paint if used;
- i) surface preparation;
- j) viewing conditions;
- k) maximum residual field strength after test, if appropriate;
- l) method of recording or marking of indications;
- m) date of test;
- n) name, qualification, and signature of the person performing the tests.

The test report shall also contain the test results, including a detailed description of the indications and a statement as to whether they meet the acceptance criteria.

Annex A (informative)

Example for determination of currents required to achieve specified tangential field strengths for various magnetization techniques

A.1 General

All formulae can be used to give the approximate current required to provide adequate magnetization for simple-shaped components or parts of larger components. When magnetization is generated from time varying currents, the rms. value is the required quantity. The current is expressed in terms of the tangential field strength, H , on the perimeter of the test zone, as required by [8.1](#). Examples of determination of currents required to achieve specified tangential field strengths for various magnetization techniques are given hereafter.

A.2 Axial current flow ([8.3.2.1](#) and [Figure 1](#))

The required current, I , is given by [Formula \(A.1\)](#):

$$I = H \times p \quad (\text{A.1})$$

where

I is the current [A];

p is the component perimeter [mm];

H is the tangential field strength [kA/m].

With items of varying cross section, a single value of current shall be used only when the current values required to magnetize the largest and smallest sections are in a ratio of less than 1,5:1. When a single value of current is used the largest section shall govern the current value.

A.3 Prods; Current flow ([8.3.2.2](#) and [Figures 2](#) and [3](#))

To inspect a rectangular test zone as shown in [Figures 2](#) and [3](#), the rms. Current, I , is given by [Formula \(A.2\)](#):

$$I = 2,5 H \times d \quad (\text{A.2})$$

where

I is the intensity of current [A];

d is the prod spacing [mm];

H is the tangential field strength [kA/m].

This formula applies for d up to 200 mm.

Alternatively, the test zone can be a circle inscribed between the prods but excluding the area within 25 mm of each prod. In this case,

$$I = 3H \times d \quad (\text{A.3})$$

In both cases, the formulae are only reliable when the radius of curvature of the inspection surface exceeds half the prod spacing.

A.4 Induced current flow (8.3.2.3 and Figure 4)

The required current, I_{ind} , is given by Formula (A.4):

$$I_{\text{ind}} = H \times p \quad (\text{A.4})$$

where

I_{ind} is the current [A];

p is the component perimeter [mm];

H is the tangential field strength [kA/m].

With items of varying cross section, a single value of current shall be used only when the current values required to magnetize the largest and smallest sections are in a ratio of less than 1,5:1. When a single value of current is used, the largest section shall govern the current value.

NOTE The induced current cannot be easily calculated from the primary current.

A.5 Threading conductor (8.3.3.1 and Figure 5)

For a central conductor, the current is given by A.1.

If the test part is a hollow pipe or similar item, the current shall be calculated according to the outside diameter when testing the outside surface, and according to the inside diameter when testing the inner surface.

A.6 Adjacent conductor (8.3.3.2 and Figures 6 and 7)

To achieve the required magnetization, the cable shall be mounted so that its centreline is at a perpendicular distance, d , from the test surface.

The width of the effective test area on each side of the cable centreline is then d , and the rms current flowing in the cable is required to be:

$$I = 4\pi \times d \times H \quad (\text{A.5})$$

where

I is the rms current [A];

d is the distance of cable above the surface [mm];

H is the tangential field strength [kA/m].

When testing radiused corners on cylindrical components or branch joints (e.g. stub-to-header welds), the cable can be wrapped around the surface of the component or the branch and several turns may be

bunched in the form of a closely wrapped coil as shown in [Figure 7](#). In this case, the surface inspected shall lie within a distance, d , of the cable or the coil windings, where $d = NI/4H$ and NI are the ampere-turns.

A.7 Rigid coil ([8.3.3.5](#) and [Figure 10](#))

Where the component occupies less than 10 % of the coil cross-sectional area and the component is placed along the axis at the bottom of the coil, [Formula \(A.6\)](#) shall apply and the test shall be repeated at coil-length intervals.

$$NI = \frac{0,4H \times K}{L/D} \quad (\text{A.6})$$

where

N is the number of effective coil turns;

I is the current [A];

H is the tangential field strength [kA/m];

L/D is the ratio of the length of a component to its diameter for components of circular section (in the case of components of non-circular section, $D = \text{perimeter}/\pi$);

$K = 22\,000$ for an AC source (rms value) and for full-wave rectified current (mean value);

$K = 11\,000$ for half-wave rectified current (mean value).

NOTE Where components have a ratio of L/D greater than 20, the ratio is considered to be 20.

With short components (i.e. L/D smaller than 5), [Formula \(A.6\)](#) results in large values of current. To minimize the current, extenders shall be used to increase the effective length of the part.

A.8 Flexible coil formed by flexible cable ([8.3.3.6](#) and [Figure 11](#))

To achieve the required magnetization using direct or rectified current, the rms value of the current flowing in the cable shall have a minimum value of:

$$I = 3H[T + (Y^2/4T)] \quad (\text{A.7})$$

where

I is the rms value of the current [A];

H is the tangential field strength [kA/m];

T is the wall thickness of the component, in millimetres, or its radius if it is in the form of a solid bar of circular section;



Y is the spacing between adjacent windings in the coil, in millimetres.

To achieve the required magnetization using alternating current, the rms value of the current flowing in the cable shall have a minimum value of

$$I = 3H[10 + (Y^2/40)] \quad (\text{A.8})$$

A.9 Wave forms

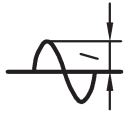
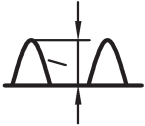
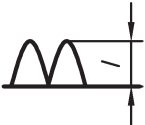
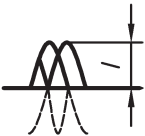
Table A.1 — Relationship between peak mean and rms values for various sinusoidal waveforms

Wave form	Peak	Mean	rms	rms/means
Alternating current 	I	0	$0,707 I$ $(=I/\sqrt{2})$	—
Alternating current half-wave rectified 	I	$0,318 I$ $(=I/\pi)$	$0,5 I$	1,57
Alternating full-wave rectified 	I	$0,637 I$ $(=2I/\pi)$	$0,707 I$ $(=I/\sqrt{2})$	1,11
Three phase half-wave rectified 	I	$0,827 I$	$0,841 I$	1,02
Three phase sinusoidal full wave rectified 	I	$0,955 I$ $(3I/\pi)$		

Bibliography

- [1] ISO 9712, *Non-destructive testing — Qualification and certification of NDT personnel*

British Standards Institution (BSI)

BSI is the national body responsible for preparing British Standards and other standards-related publications, information and services.

BSI is incorporated by Royal Charter. British Standards and other standardization products are published by BSI Standards Limited.

About us

We bring together business, industry, government, consumers, innovators and others to shape their combined experience and expertise into standards-based solutions.

The knowledge embodied in our standards has been carefully assembled in a dependable format and refined through our open consultation process. Organizations of all sizes and across all sectors choose standards to help them achieve their goals.

Information on standards

We can provide you with the knowledge that your organization needs to succeed. Find out more about British Standards by visiting our website at bsigroup.com/standards or contacting our Customer Services team or Knowledge Centre.

Buying standards

You can buy and download PDF versions of BSI publications, including British and adopted European and international standards, through our website at bsigroup.com/shop, where hard copies can also be purchased.

If you need international and foreign standards from other Standards Development Organizations, hard copies can be ordered from our Customer Services team.

Copyright in BSI publications

All the content in BSI publications, including British Standards, is the property of and copyrighted by BSI or some person or entity that owns copyright in the information used (such as the international standardization bodies) and has formally licensed such information to BSI for commercial publication and use.

Save for the provisions below, you may not transfer, share or disseminate any portion of the standard to any other person. You may not adapt, distribute, commercially exploit, or publicly display the standard or any portion thereof in any manner whatsoever without BSI's prior written consent.

Storing and using standards

Standards purchased in soft copy format:

- A British Standard purchased in soft copy format is licensed to a sole named user for personal or internal company use only.
- The standard may be stored on more than 1 device provided that it is accessible by the sole named user only and that only 1 copy is accessed at any one time.
- A single paper copy may be printed for personal or internal company use only.

Standards purchased in hard copy format:

- A British Standard purchased in hard copy format is for personal or internal company use only.
- It may not be further reproduced – in any format – to create an additional copy. This includes scanning of the document.

If you need more than 1 copy of the document, or if you wish to share the document on an internal network, you can save money by choosing a subscription product (see 'Subscriptions').

Reproducing extracts

For permission to reproduce content from BSI publications contact the BSI Copyright & Licensing team.

Subscriptions

Our range of subscription services are designed to make using standards easier for you. For further information on our subscription products go to bsigroup.com/subscriptions.

With **British Standards Online (BSOL)** you'll have instant access to over 55,000 British and adopted European and international standards from your desktop. It's available 24/7 and is refreshed daily so you'll always be up to date.

You can keep in touch with standards developments and receive substantial discounts on the purchase price of standards, both in single copy and subscription format, by becoming a **BSI Subscribing Member**.

PLUS is an updating service exclusive to BSI Subscribing Members. You will automatically receive the latest hard copy of your standards when they're revised or replaced.

To find out more about becoming a BSI Subscribing Member and the benefits of membership, please visit bsigroup.com/shop.

With a **Multi-User Network Licence (MUNL)** you are able to host standards publications on your intranet. Licences can cover as few or as many users as you wish. With updates supplied as soon as they're available, you can be sure your documentation is current. For further information, email subscriptions@bsigroup.com.

Revisions

Our British Standards and other publications are updated by amendment or revision.

We continually improve the quality of our products and services to benefit your business. If you find an inaccuracy or ambiguity within a British Standard or other BSI publication please inform the Knowledge Centre.

Useful Contacts

Customer Services

Tel: +44 345 086 9001

Email (orders): orders@bsigroup.com

Email (enquiries): cservices@bsigroup.com

Subscriptions

Tel: +44 345 086 9001

Email: subscriptions@bsigroup.com

Knowledge Centre

Tel: +44 20 8996 7004

Email: knowledgecentre@bsigroup.com

Copyright & Licensing

Tel: +44 20 8996 7070

Email: copyright@bsigroup.com

BSI Group Headquarters

389 Chiswick High Road London W4 4AL UK