

Gas cylinders — Refillable seamless steel gas cylinders — Design, construction and testing

**Part 2: Quenched and tempered
steel cylinders with tensile strength
greater than or equal to 1 100 MPa
(ISO 9809-2:2010)**

ICS 23.020.30

National foreword

This British Standard is the UK implementation of EN ISO 9809-2:2010. It supersedes BS EN 1964-2:2001 which is withdrawn.

The UK participation in its preparation was entrusted to Technical Committee PVE/3/3, Gas containers - Transportable gas containers - Cylinder design, construction and testing at the time of manufacture.

A list of organizations represented on this committee can be obtained on request to its secretary.

This publication does not purport to include all the necessary provisions of a contract. Users are responsible for its correct application.

Compliance with a British Standard cannot confer immunity from legal obligations.

This British Standard was published under the authority of the Standards Policy and Strategy Committee on 30 June 2010

© BSI 2010

ISBN 978 0 580 53692 2

Amendments/corrigenda issued since publication

Date	Comments

English Version

Gas cylinders - Refillable seamless steel gas cylinders - Design,
construction and testing - Part 2: Quenched and tempered steel
cylinders with tensile strength greater than or equal to 1 100
MPa (ISO 9809-2:2010)

Bouteilles à gaz - Bouteilles à gaz rechargeables en acier
sans soudure - Conception, construction et essais - Partie
2: Bouteilles en acier trempé et revenu ayant une
résistance à la traction supérieure ou égale à 1 100 MPa
(ISO 9809-2:2010)

Gasflaschen - Wiederbefüllbare nahtlose Gasflaschen aus
Stahl - Gestaltung, Konstruktion und Prüfung - Teil 2:
Flaschen aus vergütetem Stahl mit einer Zugfestigkeit
größer als oder gleich 1 100 MPa (ISO 9809-2:2010)

This European Standard was approved by CEN on 18 March 2010.

CEN members are bound to comply with the CEN/CENELEC Internal Regulations which stipulate the conditions for giving this European Standard the status of a national standard without any alteration. Up-to-date lists and bibliographical references concerning such national standards may be obtained on application to the CEN Management Centre or to any CEN member.

This European Standard exists in three official versions (English, French, German). A version in any other language made by translation under the responsibility of a CEN member into its own language and notified to the CEN Management Centre has the same status as the official versions.

CEN members are the national standards bodies of Austria, Belgium, Bulgaria, Croatia, Cyprus, Czech Republic, Denmark, Estonia, Finland, France, Germany, Greece, Hungary, Iceland, Ireland, Italy, Latvia, Lithuania, Luxembourg, Malta, Netherlands, Norway, Poland, Portugal, Romania, Slovakia, Slovenia, Spain, Sweden, Switzerland and United Kingdom.



EUROPEAN COMMITTEE FOR STANDARDIZATION
COMITÉ EUROPÉEN DE NORMALISATION
EUROPÄISCHES KOMITEE FÜR NORMUNG

Management Centre: Avenue Marnix 17, B-1000 Brussels

Foreword

This document (EN ISO 9809-2:2010) has been prepared by Technical Committee ISO/TC 58 "Gas cylinders" in collaboration with Technical Committee CEN/TC 23 "Transportable gas cylinders", the secretariat of which is held by BSI.

This European Standard shall be given the status of a national standard, either by publication of an identical text or by endorsement, at the latest by October 2010, and conflicting national standards shall be withdrawn at the latest by October 2010.

Attention is drawn to the possibility that some of the elements of this document may be the subject of patent rights. CEN [and/or CENELEC] shall not be held responsible for identifying any or all such patent rights.

This document supersedes EN 1964-2:2001.

This document has been prepared under a mandate given to CEN by the European Commission and the European Free Trade Association, and supports essential requirements of EU Directive(s).

For Specific European requirements, see normative Annex NA, which is an integral part of this document.

According to the CEN/CENELEC Internal Regulations, the national standards organizations of the following countries are bound to implement this European Standard: Austria, Belgium, Bulgaria, Croatia, Cyprus, Czech Republic, Denmark, Estonia, Finland, France, Germany, Greece, Hungary, Iceland, Ireland, Italy, Latvia, Lithuania, Luxembourg, Malta, Netherlands, Norway, Poland, Portugal, Romania, Slovakia, Slovenia, Spain, Sweden, Switzerland and the United Kingdom.

Endorsement notice

The text of ISO 9809-2:2010 has been approved by CEN as a EN ISO 9809-2:2010 without any modification.

Annex NA (normative) **Specific European requirements**

NA.1 Normative references

The following referenced documents are indispensable for the application of this document. For dated references, only the edition cited applies. For undated references, the latest edition of the referenced document (including any amendments) applies.

EN 473, *Non-destructive testing — Qualification and certification of NDT personnel — General principles*

EN ISO 11114-4, *Transportable gas cylinders — Compatibility of cylinder and valve materials with gas contents — Part 4: Test methods for selecting metallic materials resistant to hydrogen embrittlement*

EN ISO 13769, *Gas cylinders — Stamp marking*

NA.2 Technical requirements

With reference to the clauses in the main body of the text, the following additional requirements shall apply:

5 Inspection and testing

The following informative note shall be added to Clause 5:

“NOTE The conformity of cylinders shall be assessed in accordance with the regulations in force at the time of manufacture. RID/ADR/ADN includes requirements for conformity assessment consisting of type approval, supervision of manufacture and initial inspection and test. If conformity is assessed in accordance with Council Directive 99/36/EC on transportable pressure equipment (TPED), modules B+D or B+F should be used. If other modules are used, the cylinders will not be in conformity with this standard and the number of this standard shall not be marked.”

11.2 Hydraulic test

11.2.2 Volumetric expansion test

“NOTE The initial inspection and tests regarding hydraulic test are regulated by RID, ADR which take precedence over Clause 11.2.2.

13 Marking

Marking shall be in accordance with EN ISO 13769.

“NOTE The marking of gas cylinders is regulated by RID, ADR and ADN which take precedence over any clause in this standard. The European Directive on the TPED includes additional marking requirements (π -marking). It is important to know that these provisions are subject to regular revisions. This may lead to temporary noncompliance with EN ISO 13769.”

Annex A

Annex A shall be taken as normative.

B.2 General requirements

The second paragraph shall be replaced by the following: "The operation of the test equipment shall be by personnel certified at least to level 1 of EN 473 and supervised by qualified and experienced personnel certified to level 2 or level 3 of EN 473.

Additionally the following note shall be added to the end of this clause:

"NOTE As it is considered that the qualifications of personnel according to EN 473 and ISO 9712 are comparable, certification of the personnel to either standard should be accepted."

Contents

Page

Foreword	iv
Introduction.....	v
1 Scope	1
2 Normative references	1
3 Terms and definitions	2
4 Symbols.....	3
5 Inspection and testing	4
6 Materials	4
7 Design.....	7
8 Construction and workmanship	11
9 Type approval procedure.....	13
10 Batch tests	19
11 Tests/examinations on every cylinder	27
12 Certification.....	28
13 Marking.....	29
Annex A (informative) Description and evaluation of manufacturing imperfections and conditions for rejection of seamless steel gas cylinders at time of final visual inspection by the manufacturer.....	30
Annex B (normative) Ultrasonic examination	36
Annex C (informative) Type approval certificate	42
Annex D (informative) Acceptance certificate.....	43
Bibliography.....	45

Foreword

ISO (the International Organization for Standardization) is a worldwide federation of national standards bodies (ISO member bodies). The work of preparing International Standards is normally carried out through ISO technical committees. Each member body interested in a subject for which a technical committee has been established has the right to be represented on that committee. International organizations, governmental and non-governmental, in liaison with ISO, also take part in the work. ISO collaborates closely with the International Electrotechnical Commission (IEC) on all matters of electrotechnical standardization.

International Standards are drafted in accordance with the rules given in the ISO/IEC Directives, Part 2.

The main task of technical committees is to prepare International Standards. Draft International Standards adopted by the technical committees are circulated to the member bodies for voting. Publication as an International Standard requires approval by at least 75 % of the member bodies casting a vote.

Attention is drawn to the possibility that some of the elements of this document may be the subject of patent rights. ISO shall not be held responsible for identifying any or all such patent rights.

ISO 9809-2 was prepared by Technical Committee ISO/TC 58, *Gas cylinders*, Subcommittee SC 3, *Cylinder design*.

This second edition cancels and replaces the first edition (ISO 9809-2:2000), which has been technically revised.

- a) the reduction of maximum sulfur content in 6.2.2 from 0,010 % to 0,005 %, which is now applicable to all strength levels;
- b) the note in 7.3 regarding limitation of the F factor was deleted (as required by the United Nations *Recommendations on the Transport of Dangerous Goods: Model Regulations*);
- c) the modification of provisions for ultrasonic examination in 8.4 to include ultrasonic examination on the cylindrical area to be closed, prior to the forming process;
- d) the addition of the requirement of a base check according to 9.2.6 for all cylinder types during prototype testing;
- e) the addition of the requirement of a base check according to 9.2.6 for cylinders made from continuously cast billet material during batch testing.

ISO 9809 consists of the following parts, under the general title *Gas cylinders — Refillable seamless steel gas cylinders — Design, construction and testing*:

- *Part 1: Quenched and tempered steel cylinders with tensile strength less than 1 100 MPa*
- *Part 2: Quenched and tempered steel cylinders with tensile strength greater than or equal to 1 100 MPa*
- *Part 3: Normalized steel cylinders*

Stainless steel cylinders with tensile strength of less than 1 100 MPa will form the subject of a part 4.

Introduction

This part of ISO 9809 provides a specification for the design, manufacture, inspection and testing of a seamless steel cylinder for worldwide usage. The objective is to balance design and economic efficiency against international acceptance and universal utility.

ISO 9809 (all parts) aims to eliminate existing concern; about climate, duplicate inspections and restrictions because of a lack of definitive International Standards. This part of ISO 9809 should not be construed as reflecting on the suitability of the practice of any nation or region.

This part of ISO 9809 addresses the general requirements on design, construction and initial inspection and test of pressure receptacles of the United Nations *Recommendations on the Transport of Dangerous Goods: Model Regulations*.

It is intended to be used under a variety of regulatory regimes, but is suitable for use with the conformity assessment system in 6.2.2.5 of the above-mentioned Model Regulations.

Gas cylinders — Refillable seamless steel gas cylinders — Design, construction and testing —

Part 2:

Quenched and tempered steel cylinders with tensile strength greater than or equal to 1 100 MPa

1 Scope

This part of ISO 9809 specifies minimum requirements for the material, design, construction and workmanship, manufacturing processes, examination and testing at manufacture of refillable quenched and tempered seamless steel gas cylinders of water capacities from 0,5 l up to and including 150 l for compressed, liquefied and dissolved gases. This part of ISO 9809 is applicable to cylinders with a maximum tensile strength $R_{ma} \geq 1\,100$ MPa. It is not applicable to cylinders with $R_{ma, max} > 1\,300$ MPa for diameters > 140 mm and guaranteed wall thicknesses $a' \geq 12$ mm and $R_{ma, max} > 1\,400$ MPa for diameters ≤ 140 mm and guaranteed wall thicknesses $a' \geq 6$ mm, because beyond these limits, additional requirements can apply.

NOTE 1 If desired, cylinders of water capacity less than 0,5 l and between 150 l and 500 l can be manufactured and certified to be in compliance with this part of ISO 9809.

NOTE 2 For quenched and tempered steel cylinders with maximum tensile strength less than 1 100 MPa, see ISO 9809-1. For normalized steel cylinders, see ISO 9809-3.

NOTE 3 Grades and strength ranges of steels used for these types of cylinders might not be compatible with some gas service (see 6.1.4) and operational conditions.

2 Normative references

The following referenced documents are indispensable for the application of this document. For dated references, only the edition cited applies. For undated references, the latest edition of the referenced document (including any amendments) applies.

ISO 148-1, *Metallic materials — Charpy pendulum impact test — Part 1: Test method*

ISO 6506-1, *Metallic materials — Brinell hardness test — Part 1: Test method*

ISO 6508-1, *Metallic materials — Rockwell hardness test — Part 1: Test method (scales A, B, C, D, E, F, G, H, K, N, T)*

ISO 6892-1, *Metallic materials — Tensile testing — Part 1: Method of test at room temperature*

ISO 7438, *Metallic materials — Bend test*

ISO 9329-1, *Seamless steel tubes for pressure purposes — Technical delivery conditions — Part 1: Unalloyed steels with specified room temperature properties*

ISO 9712, *Non-destructive testing — Qualification and certification of personnel*

ISO 11114-1, *Transportable gas cylinders — Compatibility of cylinder and valve materials with gas contents — Part 1: Metallic materials*

ISO 13769, *Gas cylinders — Stamp marking*

3 Terms and definitions

For the purposes of this document, the following terms and definitions apply.

3.1 batch
quantity of up to 200 cylinders plus cylinders for destructive testing of the same nominal diameter, thickness, length and design made successively on the same equipment, from the same cast of steel and subjected to the same heat treatment for the same duration of time

3.2 burst pressure
 p_b
highest pressure reached in a cylinder during a burst test

3.3 design stress factor
 F
ratio of equivalent wall stress at test pressure, p_h , to guaranteed minimum yield strength, R_{eg}

3.4 quenching
hardening heat treatment in which a cylinder, which has been heated to a uniform temperature above the upper critical point, Ac_3 , of the steel, is cooled rapidly in a suitable medium

3.5 tempering
toughening heat treatment which follows quenching, in which the cylinder is heated to a uniform temperature below the lower critical point, Ac_1 , of the steel

3.6 test pressure
 p_h
required pressure applied during a pressure test

NOTE It is used for cylinder wall thickness calculation.

3.7 working pressure
settled pressure of a compressed gas at a uniform reference temperature of 15 °C in a full gas cylinder

3.8 yield strength
stress value corresponding to the upper yield strength, ReH , or for steels which do not exhibit a defined yield, the 0,2 % proof strength (non-proportional extension), $Rp0,2$ (see ISO 6892-1)

4 Symbols

a	Calculated minimum thickness, in millimetres, of the cylindrical shell
a'	Guaranteed minimum thickness, in millimetres, of the cylindrical shell
a_1	Guaranteed minimum thickness, in millimetres, of a concave base at the knuckle (see Figure 2)
a_2	Guaranteed minimum thickness, in millimetres, at the centre of a concave base (see Figure 2)
A	Percentage elongation after fracture
b	Guaranteed minimum thickness, in millimetres, at the centre of a convex base (see Figure 1)
c	Maximum permissible deviation of burst profile, in millimetres (see Figure 12 and Figure 13)
d	Depth of artificial flaw, in millimetres, in flawed cylinder burst test and flawed cylinder cycle test (see Figure 5)
D	Nominal outside diameter of the cylinder, in millimetres (see Figure 1 and Figure 2)
D_c	External diameter, in millimetres, of cutter milling tool for flawed cylinder burst test and flawed cylinder cycle test (see Figure 5)
D_f	Diameter, in millimetres, of former (see Figure 8)
F	Design stress factor (variable) (see 3.3)
h	Outside depth (concave base end), in millimetres (see Figure 2)
H	Outside height, in millimetres, of domed part (convex head or base end) (see Figure 1)
l_o	Length of artificial flaw, in millimetres, in flawed cylinder burst test and flawed cylinder cycle test (see Figure 5)
l	Length of cylindrical part of the cylinder, in millimetres (see Figure 3)
L_o	Original gauge length, in millimetres, as defined in ISO 6892-1 (see Figure 7)
n	Ratio of the diameter of the bend test former to actual thickness of test piece, t
p_b	Measured burst pressure, in bars ¹⁾ , above atmospheric pressure
p_f	Measured failure pressure, in bars, above atmospheric pressure
p_h	Hydraulic test pressure, in bars, above atmospheric pressure
p_y	Observed pressure when cylinder starts yielding during hydraulic bursting test, in bars, above atmospheric pressure
r	Inside knuckle radius, in millimetres (see Figure 1 and Figure 2)
r_c	Cutter tip radius of milling tool for artificial flaw, in millimetres, for flawed cylinder burst test and flawed cylinder cycle test (see Figure 5)
R_{eg}	Minimum guaranteed value of the yield strength (see 7.1.1), in megapascals, for the finished cylinder
R_{ea}	Actual value of the yield strength, in megapascals, as determined by the tensile test (see 10.2)

1) 1 bar = 10^5 Pa = 0,1 MPa.

R_{mg}	Minimum guaranteed value of the tensile strength, in megapascals, for the finished cylinder
R_{ma}	Actual value of tensile strength, in megapascals, as determined by the tensile test (see 10.2)
$R_{ma, max}$	Maximum actual value of the tensile strength range, in megapascals
$R_{ma, min}$	Minimum actual value of the tensile strength range, in megapascals
S_o	Original cross-sectional area of tensile test piece, in square millimetres, in accordance with ISO 6892-1
t	Actual thickness of the test specimen, in millimetres
t_m	Average cylinder wall thickness at position of testing during the flattening test, in millimetres
V	Water capacity of cylinder, in litres
w	Width, in millimetres, of the tensile test piece (see Figure 7)

5 Inspection and testing

NOTE Evaluation of conformity can be carried out according to the regulations recognized by the country(ies) in which the cylinders are intended to be used.

To ensure that the cylinders conform to this part of ISO 9809, they shall be subject to inspection and testing in accordance with Clauses 9, 10 and 11 by an inspection body (hereinafter referred to as "the inspector") authorized to do so.

Equipment used for measurement, testing and examination during production shall be maintained and calibrated within a documented quality management system.

6 Materials

6.1 General requirements

6.1.1 Materials for the manufacture of gas cylinders shall fall within one of the following categories:

- a) internationally recognized cylinder steels;
- b) nationally recognized cylinder steels;
- c) new cylinder steels resulting from technical progress.

For all categories, the relevant conditions specified in 6.2 and 6.3 shall be satisfied.

6.1.2 The material used for the manufacture of gas cylinders shall be steel, other than rimming quality, with non-ageing properties, and shall be fully killed with aluminium and/or silicon.

In cases where examination of this non-ageing property is required by the customer, the criteria by which it is to be specified should be agreed with the customer and inserted in the order.

6.1.3 The cylinder manufacturer shall establish means to identify the cylinders with the cast of steel from which they are made.

6.1.4 High strength cylinders made in accordance with this part of ISO 9809 are normally not compatible with corrosive or embrittling gases (see ISO 11114-1). They may nevertheless be used with these gases provided that their compatibility is proven by a recognized test method, e.g. ISO 11114-4.

6.1.5 Wherever continuously cast billet material is used, the manufacturer shall ensure that there are no deleterious imperfections (porosity) in the material to be used for making cylinders (see 9.2.6)

6.2 Controls on chemical composition

6.2.1 The chemical composition of all steels shall be defined at least by:

- the carbon, manganese and silicon contents in all cases;
- the chromium, nickel and molybdenum contents or other alloying elements intentionally added to the steel;
- the maximum sulfur and phosphorus contents in all cases.

The carbon, manganese and silicon contents and, where appropriate, the chromium, nickel and molybdenum contents shall be given, with tolerances, such that the differences between the maximum and minimum values of the cast do not exceed the values shown in Table 1.

Table 1 — Chemical composition tolerances

Element	Maximum content (mass fraction)	Permissible range (mass fraction)
	%	%
Carbon	< 0,30 %	0,03
	≥ 0,30 %	0,04
Manganese	All values	0,20
Silicon	All values	0,15
Chromium	< 1,20 %	0,20
	≥ 1,20 %	0,30
Nickel	All values	0,30
Molybdenum	< 0,50 %	0,10
	≥ 0,50 %	0,15

The combined content of the following elements: vanadium, niobium, titanium, boron and zirconium, shall not exceed 0,15 %.

The actual content of any element deliberately added shall be reported and their maximum content shall be representative of good steel making practice.

6.2.2 Sulfur and phosphorus in the cast analysis of material used for the manufacture of gas cylinders shall not exceed the values shown in Table 2.

Table 2 — Maximum sulfur and phosphorus limits in % (mass fraction)

Sulfur	0,005
Phosphorus	0,015

6.2.3 The cylinder manufacturer shall obtain and provide certificates of cast (heat) analyses of the steels supplied for the construction of gas cylinders.

Should check analyses be required, they shall be carried out either on specimens taken during manufacture from the material in the form as supplied by the steel maker to the cylinder manufacturer or from finished cylinders. In any check analysis, the maximum permissible deviation from the limits specified for the cast analyses shall conform to the values specified in ISO 9329-1.

6.3 Heat treatment

6.3.1 The cylinder manufacturer shall certify the heat treatment process applied to the finished cylinders.

6.3.2 Quenching in media other than mineral oil is permissible, provided that:

- the method produces cylinders free of cracks;
- the manufacturer ensures that the rate of cooling does not produce any cracks in the cylinder;
- every production cylinder is subjected to a method of non-destructive testing to prove freedom from cracks, if the average rate of cooling in the medium is greater than 80 % of that in water at 20 °C without additives;
- during the production of cylinders, the concentration of the quenchant is checked and recorded during every shift to ensure that the limits are maintained. Further documented checks shall be carried out to ensure that the chemical properties of the quenchant are not degraded.

6.3.3 The tempering process shall achieve the required mechanical properties.

The actual temperature to which a type of steel is subjected for a given tensile strength shall not deviate by more than 30 °C from the temperature specified by the cylinder manufacturer.

6.4 Failure to meet test requirements

In the event of failure to meet the test requirements, retesting or reheat treatment and retesting shall be carried out as follows to the satisfaction of the inspector.

- a) If there is evidence of a fault in carrying out a test, or an error of measurement, a further test shall be performed. If the result of this test is satisfactory, the first test shall be ignored.
- b) If the test has been carried out in a satisfactory manner, the cause of test failure shall be identified.
 - 1) If the failure is considered to be due to the heat treatment applied, the manufacturer may subject all the cylinders implicated by the failure to a further heat treatment, e.g. if the failure is in a test representing the prototype or batch cylinders. Test failure shall require reheat treatment of all the represented cylinders prior to retesting.

This reheat treatment shall consist of re-tempering or re-quenching and tempering.

Whenever cylinders are reheat treated, the minimum guaranteed wall thickness shall be maintained.

Only the relevant prototype or batch tests needed to prove the acceptability of the new batch shall be performed again. If one or more tests prove even partially unsatisfactory, all cylinders of the batch shall be rejected.

- 2) If the failure is due to a cause other than the heat treatment applied, all cylinders with imperfections shall be either rejected or repaired such that the repaired cylinders pass the test(s) required for the repair. They shall then be re-instated as part of the original batch.

7 Design

7.1 General requirements

7.1.1 The calculation of the wall thickness of the pressure-containing parts shall be related to the guaranteed minimum yield strength, R_{eg} , of the material in the finished cylinder.

7.1.2 Cylinders may be designed with one or two openings along the central cylinder axis only.

7.1.3 For calculation purposes, the value of R_{eg} shall not exceed 0,90 R_{mg} .

7.1.4 The internal pressure upon which the calculation of wall thickness is based shall be the hydraulic test pressure p_h .

7.2 Limitation on tensile strength

The maximum value of the tensile strength is limited by the ability of the steel to meet the requirements of Clauses 9 and 10. The maximum range of tensile strength shall be 120 MPa (i.e. $R_{ma, \max} - R_{ma, \min} \leq 120$ MPa).

However, the actual value of the tensile strength as determined in 10.2 shall not exceed 1 300 MPa for cylinders with an outside diameter greater than 140 mm, and 1 400 MPa for cylinders with an outside diameter equal to or less than 140 mm.

7.3 Calculation of cylindrical shell thickness

The guaranteed minimum thickness of the cylindrical shell, a' , shall not be less than the thickness calculated using Equations (1) and (2), and additionally condition (3) shall be satisfied:

$$a = \frac{D}{2} \left(1 - \sqrt{\frac{10 F R_{eg} - \sqrt{3} p_h}{10 F R_{eg}}} \right) \quad (1)$$

where the value of F is the lesser of $\frac{0,65}{R_{eg}/R_{mg}}$ or 0,77.

R_{eg}/R_{mg} shall not exceed 0,90.

The wall thickness shall also satisfy Equation (2):

$$a \geq \frac{D}{250} + 1 \quad (2)$$

with an absolute minimum of $a = 1,5$ mm.

The burst ratio shall be satisfied by test as given in Equation (3):

$$p_b/p_h \geq 1,6 \quad (3)$$

NOTE 1 If the result of these requirements is a guaranteed thickness of the cylindrical shell $a' \geq 12$ mm for diameter $D \geq 140$ mm, or a guaranteed thickness of the cylindrical shell, $a' \geq 6$ mm for diameter $D \leq 140$ mm, such a design is outside the scope of this part of ISO 9809 (see Clause 1).

NOTE 2 It is generally assumed that $p_h = 1,5$ times working pressure for compressed gases for cylinders designed and manufactured to this part of ISO 9809.

7.4 Calculation of convex ends (heads and bases)

7.4.1 The thickness, b , at the centre of a convex end shall be not less than that required by the following criteria:

where the inside knuckle radius, r , is not less than $0,075D$, then

$$b \geq 1,5 a \text{ for } 0,40 > H/D \geq 0,20;$$

$$b \geq a \text{ for } H/D \geq 0,40.$$

To obtain a satisfactory stress distribution in the region where the end joins the shell, any thickening of the end that may be required shall be gradual from the point of juncture, particularly at the base. For the application of this rule, the point of juncture between the shell and the end is defined by the horizontal lines indicating dimension H in Figure 1.

7.4.2 The cylinder manufacturer shall prove by the pressure cycling test detailed in 9.2.3 that the design is satisfactory.

The shapes shown in Figure 1 are typical of convex heads and base ends. Shapes a), c) and d) are base ends and shape b) is a head.

7.5 Calculation of concave base ends

When concave base ends (see Figure 2) are used, the following design values are recommended:

$$a_1 \geq 2a$$

$$a_2 \geq 2a$$

$$h \geq 0,12D$$

$$r \geq 0,075D$$

The design drawing shall at least show values for a_1 , a_2 , h and r .

To obtain a satisfactory stress distribution, the thickness of the cylinder shall increase progressively in the transition region between the cylindrical part and the base.

The cylinder manufacturer shall in any case prove by the pressure cycling test detailed in 9.2.3 that the design is satisfactory.

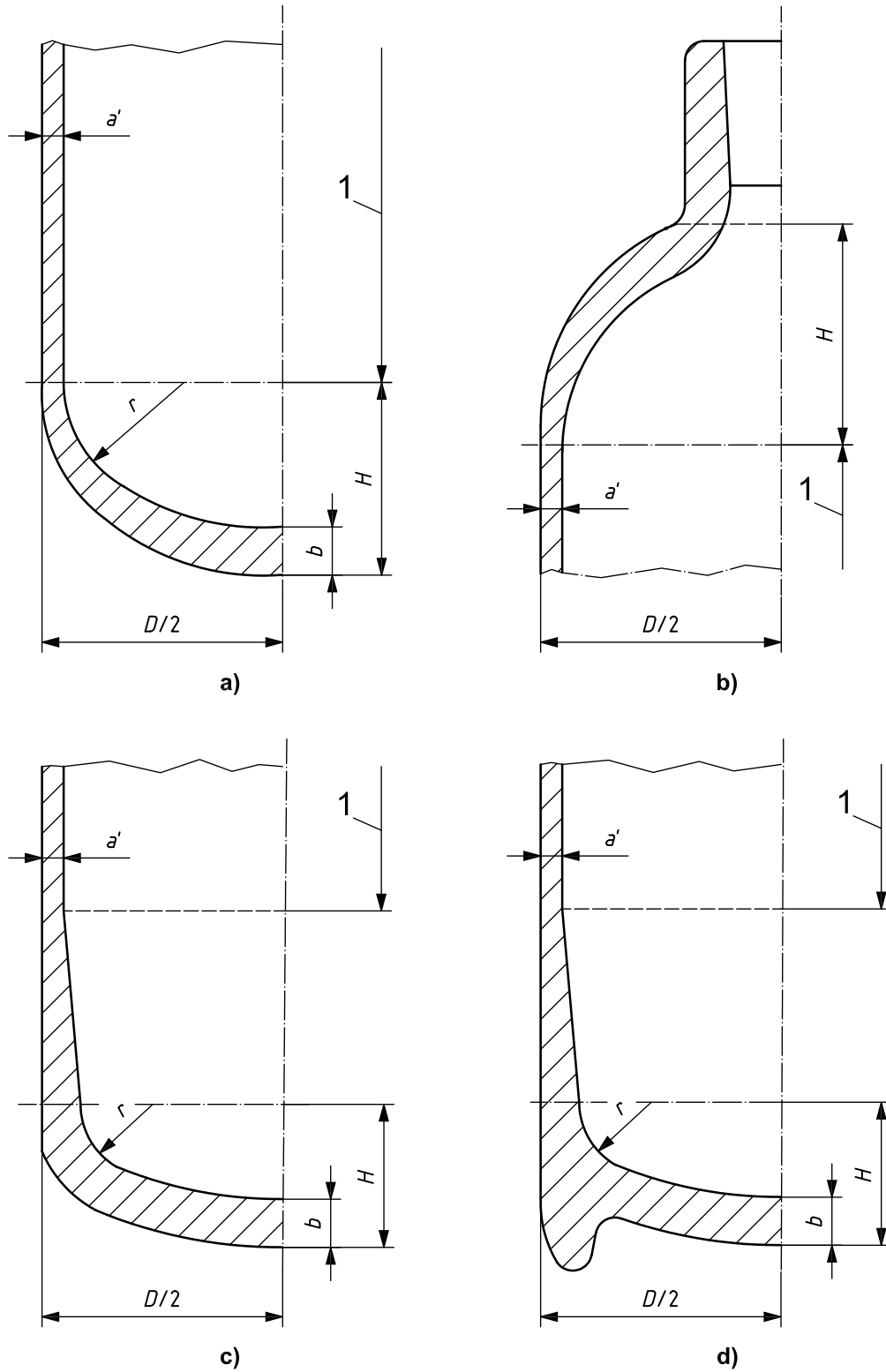

Key

1 cylindrical part

Figure 1 — Typical convex ends

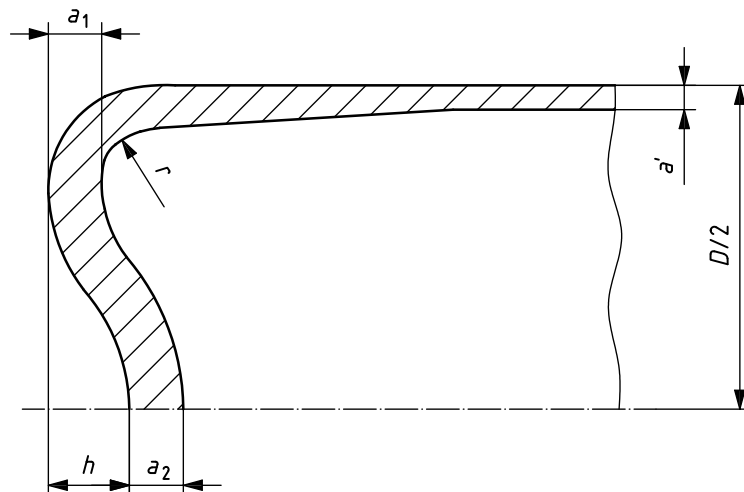

Figure 2 — Concave base end

7.6 Neck design

7.6.1 The external diameter and thickness of the formed neck end of the cylinder shall be adequate for the torque applied in fitting the valve to the cylinder. The torque may vary according to the diameter of thread, the form of thread and the sealant used in the fitting of the valve.

NOTE For guidance on torques, see ISO 13341.

7.6.2 In establishing the minimum thickness, consideration shall be given to obtaining a thickness of wall in the cylinder neck which will prevent permanent expansion of the neck during the initial and subsequent fittings of the valve into the cylinder without support of an attachment. The external diameter and thickness of the formed neck end of the cylinder shall not be damaged (no permanent expansion or crack) by the application of the maximum design torque required to fit the valve to the cylinder (see ISO 13341) and the stresses when the cylinder is subjected to its test pressure. In specific cases (e.g. very thin walled cylinders), where these stresses cannot be supported by the neck itself, the neck may be designed to require reinforcement, such as a neck ring or shrunk on collar, provided the reinforcement material and dimensions are clearly specified by the manufacturer and this configuration is part of the type approval procedure.

7.7 Foot rings

When a foot ring is provided, it shall be sufficiently strong and made of material compatible with that of the cylinder. The shape should preferably be cylindrical and shall give the cylinder sufficient stability. The foot ring shall be secured to the cylinder by a method other than welding, brazing or soldering. Any gaps which may form water traps shall be sealed by a method other than welding brazing or soldering. This is particularly important in the case of high strength cylinders.

7.8 Neck rings

When a neck ring is provided, it shall be sufficiently strong and made of material compatible with that of the cylinder and shall be securely attached by a method other than welding, brazing or soldering.

The manufacturer shall ensure that the axial load to remove the neck ring is greater than 10 times the weight of the empty cylinder and not less than 1 000 N, and that the torque to turn the neck ring is greater than 100 Nm.

7.9 Design drawing

A fully dimensioned drawing shall be prepared, which includes the specification of the material and details relevant to the design of the permanent fittings. Dimensions of non-safety related fittings can be agreed on between the customer and manufacturer and need not be shown on the design drawing.

8 Construction and workmanship

8.1 General

The cylinder shall be produced by

- a) forging or drop forging from a solid ingot or billet,
- b) manufacturing from seamless tube, or
- c) pressing from a flat plate.

Metal shall not be added in the process of closure of the end. Manufacturing defects shall not be corrected by plugging of bases.

8.2 Wall thickness

During production, each cylinder or semi-finished shell shall be examined for thickness. The wall thickness at any point shall be not less than the minimum thickness specified.

8.3 Surface imperfections

The internal and external surfaces of the finished cylinder shall be free from imperfections which could adversely affect the safe working of the cylinder.

NOTE For examples of imperfections and assistance on their evaluation, see Annex A.

8.4 Ultrasonic examination

8.4.1 After completion of the final heat treatment and after the final cylindrical wall thickness has been achieved each cylinder shall be ultrasonically examined for internal, external and sub-surface imperfections in accordance with Annex B.

For small completed cylinders with a cylindrical length of less than 200 mm or where the product of $p_h \times V < 600$, the ultrasonic examination is not necessary.

8.4.2 Regardless of the size of the cylinder, in addition to the ultrasonic examination as specified in 8.4.1, the cylindrical area to be closed (that creates the shoulder and in case of cylinders made from tube, also the base) shall be ultrasonically examined prior to the forming process to detect any defects that after closure could be positioned in the cylinder ends.

NOTE This examination does not necessarily cover the tests required in 6.3.2.

8.5 Out-of-roundness

The out-of-roundness of the cylindrical shell, i.e. the difference between the maximum and minimum outside diameters at the same cross-section, shall not exceed 2 % of the mean of these diameters.

8.6 Mean diameter

The mean outside diameter of the cylindrical part outside the transition zones on a cross-section shall not deviate by more than $\pm 1\%$ from the nominal design outside diameter.

8.7 Straightness

The maximum deviation of the cylindrical part of the shell from a straight line shall not exceed 3 mm/m length (see Figure 3).

8.8 Verticality and stability

For a cylinder designed to stand on its base, the deviation from vertical shall not exceed 10 mm/m length (see Figure 3), and the outer diameter of the surface in contact with the ground is recommended to be greater than 75 % of the nominal outside diameter.

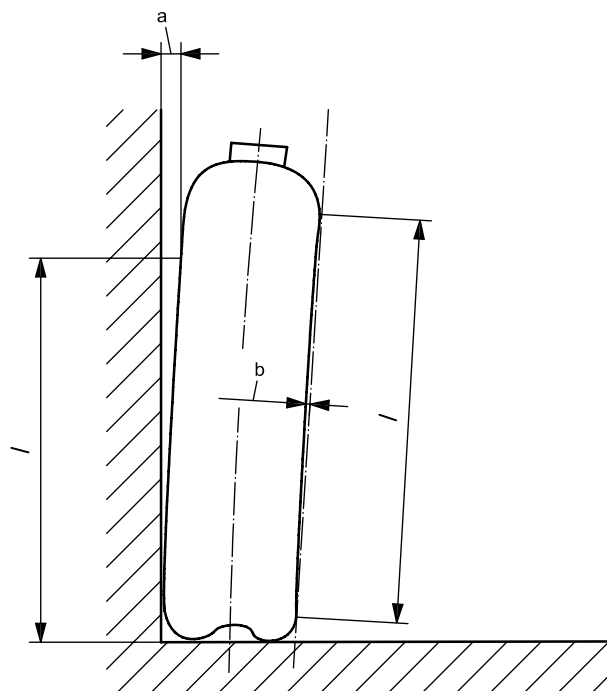

Key

- a maximum $0,01 \times l$ (see 8.8)
- b maximum $0,003 \times l$ (see 8.7)

Figure 3 — Illustration of deviation of cylindrical part of shell from a straight line and from vertical

8.9 Neck threads

The internal neck threads shall conform to a recognized standard agreed on between the parties to permit the use of a corresponding valve, thus minimizing neck stresses following the valve torquing operation. Internal neck threads shall be checked using gauges corresponding to the agreed neck thread or by an alternative method agreed on between the parties.

NOTE For example, where the neck thread is specified to be in accordance with ISO 11116-1, the corresponding gauges are specified in ISO 11116-2.

Particular care shall be taken to ensure that neck threads are accurately cut, are of full form and free from any sharp profiles e.g. burrs.

9 Type approval procedure

9.1 General requirements

A technical specification of each new design of cylinder or cylinder family as defined in f), including design drawing, design calculations, steel details, manufacturing process and heat treatment details, shall be submitted by the manufacturer to the inspector. The type approval tests detailed in 9.2 shall be carried out on each new design under the supervision of the inspector.

A cylinder shall be considered to be of a new design, compared with an existing approved design, when at least one of the following applies:

- a) it is manufactured in a different factory;
- b) it is manufactured by a different process (see 8.1); this includes the case when major process changes are made during the production period, e.g. end forging to spinning, change in heat treatment process;
- c) it is manufactured from a steel of different specified chemical composition range from that defined in 6.2.1;
- d) it is given a different heat treatment beyond the limits stipulated in 6.3;
- e) the base or the base profile has changed, e.g. concave, convex, hemispherical or also if there is a change in base thickness/cylinder diameter ratio;
- f) the overall length of the cylinder has increased by more than 50 % (cylinders with a length/diameter ratio less than 3 shall not be used as reference cylinders for any new design with this ratio greater than 3);
- g) the nominal outside diameter has changed;
- h) the guaranteed minimum thickness has changed;
- i) the hydraulic test pressure, p_h , has been increased (where a cylinder is to be used for lower-pressure duty than that for which design approval has been given, it shall not be deemed to be a new design);
- j) the guaranteed minimum yield strength, R_{eg} , and/or the guaranteed minimum tensile strength, R_{mg} , for the finished cylinder have changed.

9.2 Prototype tests

9.2.1 General requirements

A minimum of 50 cylinders, which are guaranteed by the manufacturer to be representative of the new design, shall be made available for prototype testing. However, if for special applications the total number of cylinders required is less than 50, a sufficient number of cylinders shall be made to complete the prototype tests required, in addition to the production quantity, but in this case, the approval validity is limited to this particular production batch.

In the course of the type approval process, the inspector shall select the necessary cylinders for testing and

- a) verify that:
 - the design conforms to the requirements of Clause 7.
 - the thicknesses of the walls and ends on two cylinders (those taken for mechanical testing) meet the requirements of 7.3 to 7.6, the measurements being taken at least at three transverse sections of the cylindrical part and on a longitudinal section of the base and head;

- the requirements of Clause 6 are complied with;
 - the requirements of 7.7, 7.8 and 8.5 to 8.9 inclusive are complied with for all cylinders selected for inspection;
 - the internal and external surfaces of the cylinders are free of any imperfection which might make them unsafe to use (for examples, see Annex A);
- b) supervise the following tests on the cylinders selected:
- the tests specified in 10.1.2 a) (hydraulic burst test) on two cylinders, the cylinders bearing representative stamp markings;
 - the tests specified in 10.1.2 b) (mechanical testing) on two cylinders, the test pieces' being identifiable with the batch. Hardness tests shall be carried out on the tensile test pieces to verify the hardness/tensile correlation (see 9.2.2);
 - a hardness survey, comprising four hardness tests at 90° to each other at each end of the cylindrical wall, on the two cylinders selected for mechanical testing. The maximum range of Brinell hardness on each cylinder shall be 25 HB; the manufacturer shall establish the equivalent range to this when an alternative hardness testing method is used;
 - the tests specified in 9.2.3 (pressure cycling test) on two cylinders, the cylinders bearing representative stamp markings;
 - the tests specified in 9.2.4 (flawed cylinder burst test) on at least two cylinders of the batch with the highest hardness value (mean of the two measurements);
 - the tests specified in 9.2.5 (flawed cylinder cycle test) on two cylinders;
 - the tests specified in 9.2.6 (base check) on the two cylinders selected for mechanical testing.
 - the geometrical requirements for the neck thread are complied with for all cylinders selected for inspection.

Consideration should be given to selecting cylinders which represent the lower and upper values of the hardness range within the batch.

9.2.2 Verification of hardness/tensile correlation

The manufacturer shall demonstrate to the satisfaction of the inspector that the hardness range specified is related to the tensile range specified in 7.2. When Brinell hardness testing is used, the following procedure shall be adopted.

Prior to the presentation of a first batch of cylinders for prototype testing, the manufacturer shall establish a linear regression between R_{ma} and HB for the type of steel and heat treatment method used, using a minimum of 20 values of R_{ma} and HB tested on 10 cylinders at each end. The hardness values shall be obtained on complete cylinders tested on the production line hardness testing machine; the tensile test pieces shall be taken at the hardness test spot. The values obtained shall cover the anticipated tensile range.

In order to determine the limits for the hardness range as required in 11.3, a scatter of 10 HB around HB 1 and HB 2 shall be permitted (to allow for example for measurement tolerance). The guaranteed hardness range shall therefore be:

$$HB_{min.} = HB 1 - 10 HB$$

$$HB_{max.} = HB 2 + 10 HB$$

However, the maximum hardness range $HB_{max.} - HB_{min.}$ shall not exceed 55 HB (equivalent to ≤ 200 MPa; see Figure 4).

NOTE It might be helpful to establish a separate correlation for each family of cylinders considering the different reactions (elasticity, wall thickness, etc.) to hardness testing.

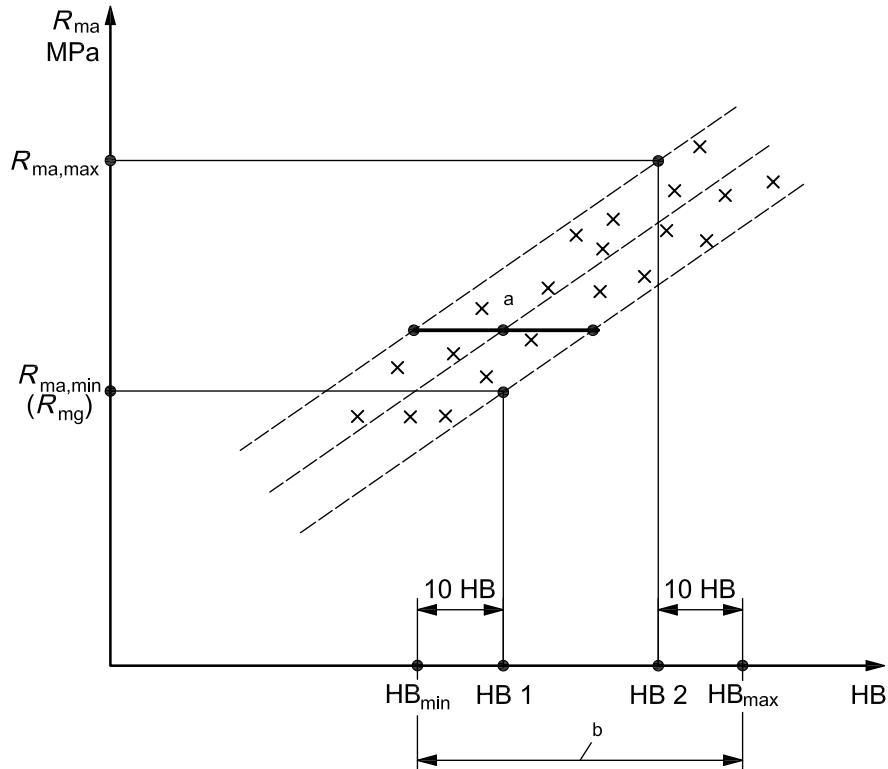

Key

- a scatter band, max. ± 10 HB
- b hardness range, max. 55 HB

Figure 4 — Hardness/tensile test graph

At the prototype stage, hardness tests shall be carried out as described in 9.2.1 b) at the spot where the tensile test specimen is taken. The results of hardness and tensile strength shall be compared with the graph established by the manufacturer to determine whether or not they are within the scatter band (see Figure 4). When hardness measurements are outside the hardness limits as stated above, see 6.4.

NOTE An equivalent test procedure can be used, provided equivalence of the scatter band and the maximum hardness range can be demonstrated.

9.2.3 Pressure cycling test

This test shall be carried out on cylinders bearing representative markings, with a non-corrosive liquid subjecting the cylinders to successive reversals at an upper cyclic pressure, which is at least equal to the hydraulic test pressure p_h . The cylinders shall withstand 12 000 cycles without failure.

For cylinders with a hydraulic test pressure $p_h > 450$ bar, the upper cyclic pressure may be reduced to two thirds of this test pressure. In this case, the cylinders shall withstand 80 000 cycles without failure.

The value of the lower cyclic pressure shall not exceed 10 % of the upper cyclic pressure, but shall have an absolute maximum of 30 bar.

The cylinder shall actually experience the maximum and minimum cyclic pressures during the test.

The frequency of reversals of pressure shall not exceed 0,25 Hz (15 cycles/min). The temperature measured on the outside surface of the cylinder shall not exceed 50 °C during the test.

After the test, the cylinder bases shall be sectioned in order to measure the thickness and to ensure that this thickness is sufficiently close to the minimum thickness prescribed in the design and shall be within the usual production tolerances. In no case shall the actual base thickness exceed the minimum value(s) specified on the drawing by more than 15 %.

The test shall be considered satisfactory if the cylinder attains the required number of cycles without developing a leak.

9.2.4 Flawed cylinder burst test

9.2.4.1 General

The flawed cylinder burst test shall be carried out to determine if the failure pressure, p_f , which produces the leak (and not a burst) with a flaw of a given size is greater than two thirds of the test pressure ($2/3 p_h$) of the cylinder, adjusted for the actual thickness versus calculated minimum wall thickness.

9.2.4.2 Details of flaw

See Figure 5.

The flaw shall be machined longitudinally, approximately at mid-length of the cylindrical part of the cylinder. The flaw shall be located at the point of minimum wall thickness, t , of the midsection, based on thickness measurement at four points around the cylinder.

The flaw length, l_o , shall be the overall length of cut and shall be at least equal to Equation (4):

$$l_o = 1,6 \sqrt{D a} \quad (4)$$

The flaw cutter shall be approximately 12,5 mm thick with an angle of 45° and a tip radius, r_c , of $(0,25 \pm 0,025)$ mm. The cutter diameter, D_c , shall be 50 mm for cylinders with a diameter, D , less than or equal to 140 mm, and 65 mm to 80 mm for cylinders with D greater than 140 mm.

A standard Charpy V-notch cutter is recommended, sharpened regularly to ensure that the tip radius meets the requirements.

The depth, d , of the flaw shall be adjusted to obtain a leak by hydropressurization. "Leak" means that the crack has not propagated by more than 10 % outside the machined flaw length, as measured on the external surface, i.e. total length shall be not greater than $1,1 \times l_o$. The flaw depth shall be at least 60% of the actual wall thickness, t , of the cylinder at the flaw location.

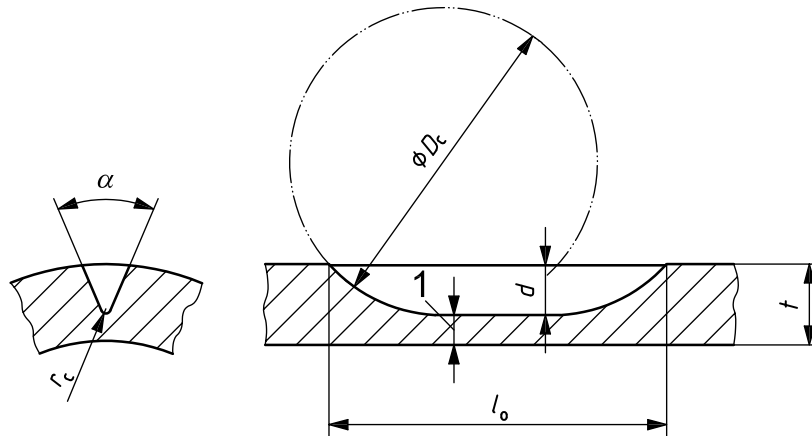

Key

- α 45° cutter angle
- 1 ligament
- D_c cutter diameter
- r_c cutter profile radius

Figure 5 — Profile of artificial flaw

9.2.4.3 Test procedure

The test shall be performed by monotonic pressurization or cyclic pressurization as described in this subclause.

a) Monotonic pressurization

The cylinder shall be pressurized hydrostatically as described in 10.5 (hydraulic bursting test), until pressure is released from the cylinder at the flaw location.

b) Cyclic pressurization

The test shall be performed as described in 9.2.3 with the upper cyclic pressure being two thirds of the test pressure ($2/3 p_h$) of the cylinder adjusted for actual thickness versus calculated minimum wall thickness (i.e. $2/3 p_h \times t/a$).

9.2.4.4 Acceptance criteria for the flawed cylinder burst test

The cylinder shall have passed the test if the following conditions are met.

a) For cylinders tested using monotonic pressurization:

- the failure pressure, p_f , shall be equal to or greater than two thirds of the test pressure ($2/3 \times p_h$) of the cylinder adjusted for the actual thickness versus calculated minimum wall thickness and the failure mode shall be by a “leak”, i.e. $p_f/(2/3 p_h) \geq 1,0 t/a$;
- if these requirements are not fulfilled (i.e. failure occurs below $2/3 p_h \times 1,0 t/a$), but the failure mode is a leak, a new test may be performed with a shallower flaw. If burst type failure occurs at a pressure greater than $2/3 p_h \times 1,0 t/a$, but the flaw depth is shallow, a new test may be performed with a deeper flaw;
- a total crack length measured on the external surface of 1,1 times the original machined length is allowed, i.e. total crack length shall not be greater than $1,1 l_o$.

b) For cylinders tested using cyclic pressurization:

- fatigue crack growth beyond the original machined flaw length is allowed. However, the failure mode shall be by a “leak”.

9.2.5 Flawed cylinder cycle test

9.2.5.1 Test conditions

The flawed cylinder cycle test shall be carried out as described in 9.2.3, with the exception that the cycling frequency shall not exceed 5 cycles/min.

The cylinders shall contain an artificial flaw as described in 9.2.5.2.

9.2.5.2 Details of flaw

See Figure 5.

The flaw shall be machined longitudinally, approximately at mid-length of the cylindrical part of the cylinder. The flaw shall be located at minimum wall thickness, t , of the midsection.

The flaw length, l_0 , shall be the overall length of cut and shall be at least equal to:

$$l_0 = 1,6 \sqrt{D} a \pm 1 \text{ mm}$$

The flaw cutter shall be approximately 12,5 mm thick with an angle of 45° and a tip radius, r_c of $(0,25 \pm 0,025)$ mm. The cutter diameter, D_c , shall be 50 mm for cylinders with a diameter D less than or equal to 140 mm, and 65 mm to 80 mm for cylinders with D greater than 140 mm.

A standard Charpy V-notch cutter is recommended, sharpened regularly to ensure that the tip radius meets the requirements.

The depth, d , of the flaw shall be not less than 10 % of the wall thickness t .

When measuring the actual flaw depth, a deviation not exceeding 0,1 mm is acceptable (e.g. for an actual wall thickness of 7,0 mm the flaw depth shall in no case be less than 0,6 mm).

9.2.5.3 Acceptance criteria for the flawed cylinder cycle test

The cylinder shall have passed the test if the number of cycles attained without failure exceeds 3 500, as a mean value of the two cylinders tested, but with an absolute minimum of 3 000.

The test report shall include actual details of the test as follows, in addition to cylinder design details:

- pressure range;
- cycle rate;
- temperature range;
- actual flaw length;
- actual wall thickness;
- actual flaw depth;
- number of cycles obtained without failure.

If the test is continued to failure, the mode of failure shall be reported (i.e. leak or burst).

If the cylinders pass a minimum of 12 000 cycles without failure, the unflawed pressure cycling test as required in 9.2.1 b) and specified in 9.2.3 need not be carried out.

9.2.6 Base check

A meridian section shall be made in the base centre of the cylinder and one of the surfaces thus obtained polished for examination under a magnification of between $\times 5$ and $\times 10$.

The cylinder shall be regarded as defective if the presence of cracks is detected. It shall also be regarded as defective if the dimensions of any pores or inclusions present reach values considered to pose a threat to safety.

In cases where the base is suspected to be plugged, the section shall be etched after the first examination to verify the absence of a plug. Plugged cylinders shall not be approved.

In no case shall the sound thickness (i.e. the thickness with no imperfections) in the base centre be less than the minimum specified thickness (see 7.4.1).

9.3 Type approval certificate

If the results of the prototype tests and checks according to 9.2 are satisfactory, the inspector shall issue a type approval certificate. Annex C provides a typical example of a suitable form of type approval certificate. Other formats with at least the same content are also acceptable.

10 Batch tests

10.1 General requirements

10.1.1 All tests for checking the quality of the gas cylinder shall be carried out on material from finished cylinders. Each cast of steel shall be represented by a set of batch test results (see 3.1).

For the purposes of batch testing, the manufacturer shall provide the inspector with:

- the type approval certificate;
- the certificates stating the cast analysis of the steel supplied for the construction of the cylinders;
- evidence that appropriate heat treatment has been performed;
- certificates showing the ultrasonic examination results;
- a list of the cylinders, stating serial numbers and stamp markings as required;
- confirmation that threads have been checked in accordance with gauging requirements. The gauges to be used shall be specified (e.g. ISO 11191).

10.1.2 During batch testing, the inspector shall undertake the following.

- Ascertain that the type approval certificate has been obtained and that the cylinders conform to it.
- Check whether the requirements given in Clauses 5, 6 and 7 have been met and, in particular, check by an external and internal visual examination of the cylinders whether their construction is satisfactory. The inspector shall verify that the requirements of 7.7, 7.8 and 8.2 to 8.9 have been fulfilled by the manufacturer. The visual examination shall cover at least 10 % of the cylinders submitted. However, if an unacceptable imperfection is found (for examples, see Annex A), 100 % of cylinders shall be visually inspected.

- Select the necessary cylinders per batch for destructive testing and carry out the tests specified in 10.1.2 a) (hydraulic burst tests) and 10.1.2 b) (mechanical testing). Where alternative tests are permitted, the purchaser and manufacturer shall agree on which tests are to be carried out.
- Supervise the test specified in 9.2.4 (flawed cylinder burst test) on one cylinder when the Charpy values do not meet the B-values in Table 3 (see 10.4.2);
- Supervise the test specified in 9.2.4 (flawed cylinder burst test) on two cylinders when the Charpy values are less than 80 % of the approved Charpy values (i.e. those obtained during the type approval), and the approved Charpy values are higher than the B-values in Table 3 (see 10.4.2). If the flawed cylinder burst test is then satisfied, the new values shall become the approved reference Charpy values.
- Supervise the test specified in 9.2.4 (flawed cylinder burst test) for cylinders with a wall thickness < 3 mm where no impact tests are required. This test shall be carried out on one cylinder per cast or, if the cast exceeds 1 000 cylinders, one cylinder per 1 000 cylinders or part thereof.
- Check whether the information supplied by the manufacturer referred to in 10.1.1 is correct; random checks shall be carried out.
- Assess the results of hardness testing referred to in 11.3.

NOTE Consideration can be given to selecting cylinders representing the lower and upper values of the hardness range within the batch.

The following tests shall be carried out on each batch of cylinders.

- a) On one cylinder, one hydraulic bursting test (see 10.5).
- b) On a further cylinder:
 - one tensile test in the longitudinal direction (see 10.2);
 - either two bend tests (see 10.3.1) in a circumferential direction, one flattening test (see 10.3.2) or one ring flattening test (see 10.3.3);
 - when the thickness of the cylinder permits the machining of a test piece at least 3 mm thick, three impact tests in the transverse or longitudinal direction as required in 10.4;
 - for cylinders made from continuously cast billet material, a base check in accordance with 9.2.6.

NOTE For the location of test pieces, see Figure 6.

- c) If necessary, on further cylinders:
 - one or two flawed cylinder burst tests, depending on the Charpy impact values obtained in the batch test.

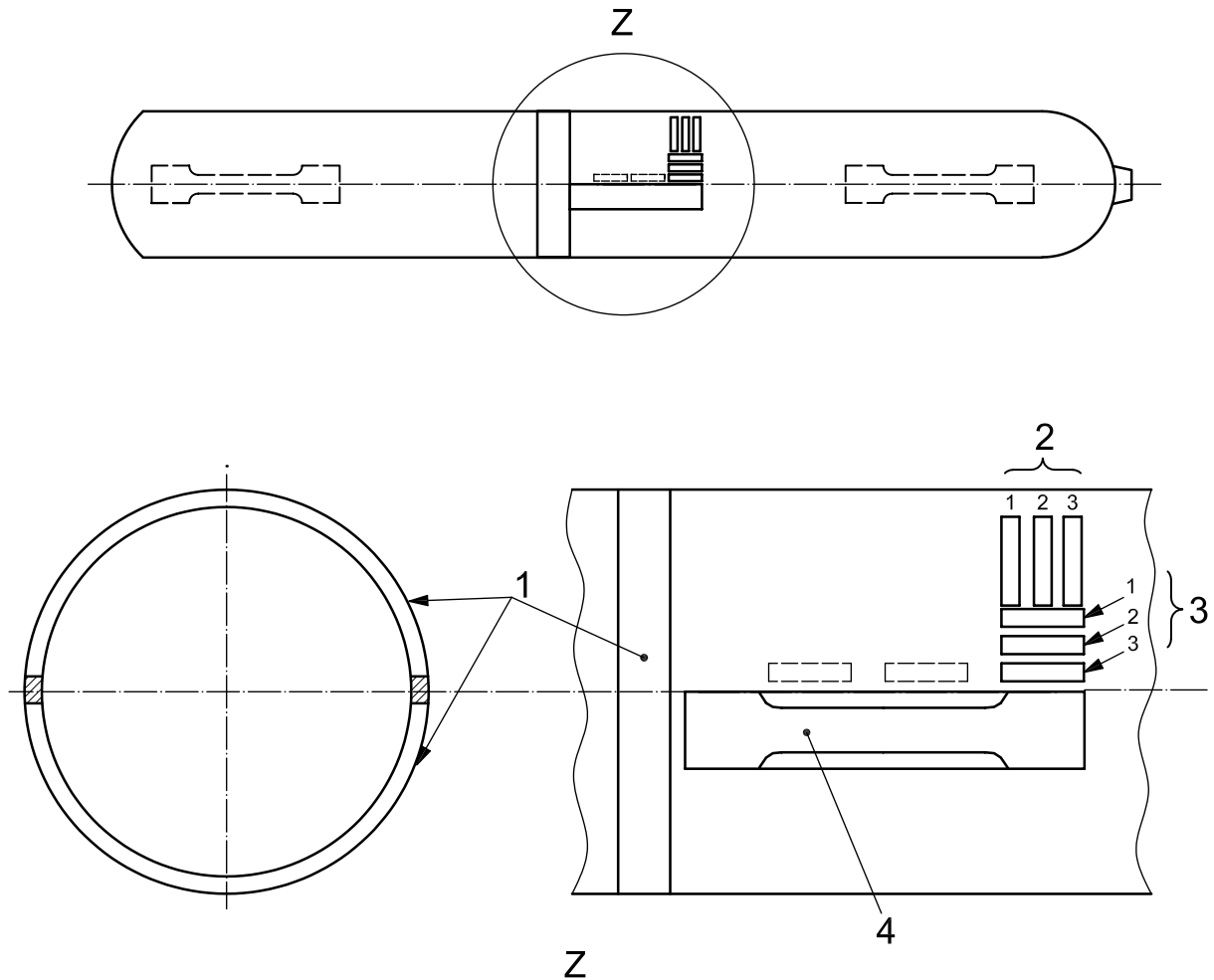

Key

1 hardness/tensile strength correlation tests (prototype tests only)

NOTE Dashed lines indicate that these tests are not required on every batch of cylinders, but for prototype testing only.

2 bend test pieces or flattening ring

3 impact test pieces (longitudinal and transverse)

4 tensile test piece

Figure 6 — Typical location of test pieces

10.2 Tensile test

10.2.1 A tensile test shall be carried out on material taken from the cylindrical part of the cylinder by adopting either of the following procedures.

- a) Rectangular specimens shall be prepared in accordance with Figure 7 and with a gauge length $L_0 = 5,65 \sqrt{S_0}$. The two faces of the test piece representing the inside and outside surfaces of the cylinder shall not be machined. The elongation after fracture, A , measured shall be not less than 12 %.
- b) Machined round specimens shall be prepared having the maximum diameter practicable, the elongation, A , measured on a gauge length of five times the specimen diameter being no less than 14 %.

It is recommended that machined round specimens not be used for wall thickness less than 3 mm.

10.2.2 The tensile test shall be carried out in accordance with ISO 6892-1.

NOTE Attention is drawn to the method of measurement of elongation described in ISO 6892-1, particularly in cases where the tensile test piece is tapered, resulting in a point of fracture away from the middle of the gauge length.

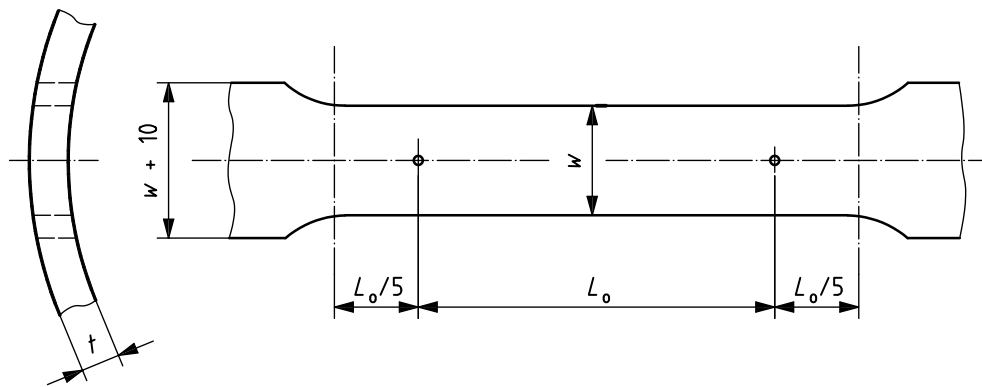

$w \leq 4t$
 $w < D/8$

Figure 7 — Tensile test piece

10.3 Bend test and flattening test

10.3.1 Bend test

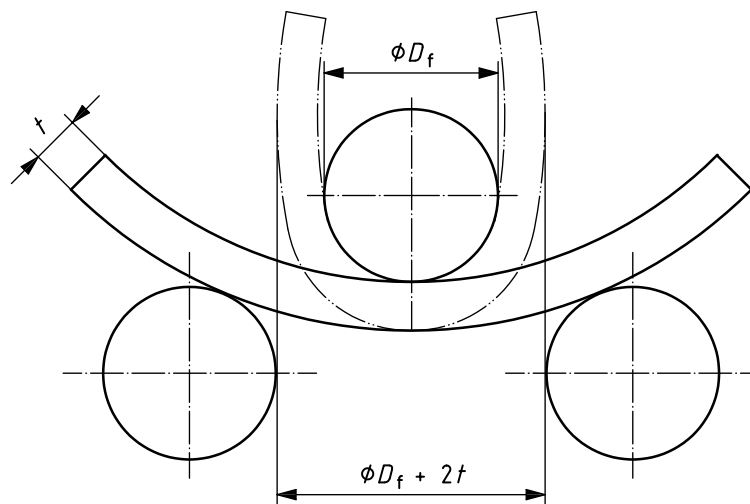

Figure 8 — Illustration of bend test

10.3.1.1 The bend test shall be carried out in accordance with ISO 7438 on two test pieces obtained by cutting either one or two rings of width 25 mm or $4t$, whichever is greater, into equal parts. Each test piece shall be of sufficient length to permit the bend test to be carried out correctly. Only the edges of each strip may be machined.

10.3.1.2 The test piece shall not crack when bent inwards around the former until the inside surfaces are not further apart than the diameter of the former (see Figure 8).

10.3.1.3 The diameter of the former, D_f , shall be not more than eight times the actual wall thickness of the test piece, t .

10.3.2 Flattening test

10.3.2.1 The flattening test shall be performed on one cylinder selected from each batch after heat treatment.

10.3.2.2 The test cylinder shall be flattened between wedge-shaped knife edges with a 60° included angle, the edges being rounded to a nominal radius of 13 mm. The length of the wedges shall be not less than the width of the flattened cylinder. The longitudinal axis of the cylinder shall be at an angle of approximately 90° to the knife edges.

10.3.2.3 The test cylinder shall be flattened until the distance between the knife edges is $10 t_m$, where t_m is the average cylinder wall thickness at the position of testing. The flattened cylinder shall remain visually uncracked.

10.3.3 Ring flattening test

The ring flattening test shall be carried out on one ring of width 25 mm or $4 t$, whichever is the greater, taken from the cylinder body. Only the edges of the ring may be machined. The ring shall be flattened between platens until the distance between platens is 10 times the average thickness of the test ring. The flattened ring shall remain visually uncracked.

10.4 Impact test

10.4.1 Except for the requirements set out below, the test shall be carried out in accordance with ISO 148-1.

The impact test pieces shall be taken in the direction as required in Table 3 from the wall of the cylinder. The notch shall be perpendicular to the face of the cylinder wall (see Figure 9). For longitudinal tests, the test piece shall be machined all over (on six faces). If the wall thickness does not permit a final test piece width of 10 mm, the width shall be as near as practicable to the nominal thickness of the cylinder wall. The test pieces taken in the transverse direction shall be machined on four faces only, the outer face of the cylinder wall unmachined and the inner face optionally machined as shown in Figure 10.

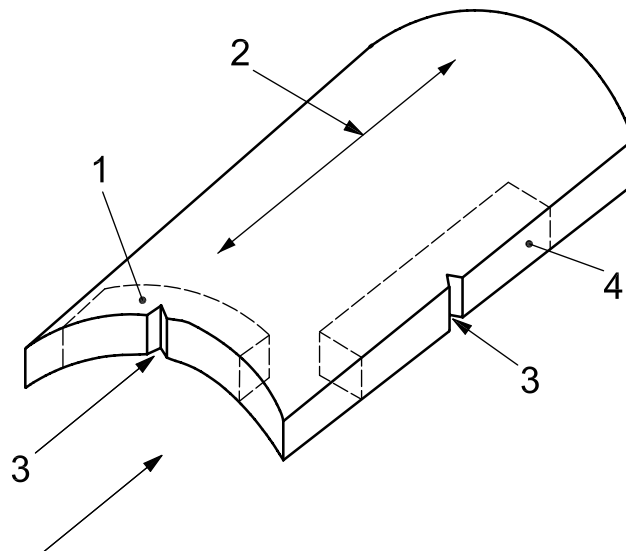

Key

- 1 transverse test piece
- 2 cylinder longitudinal axis
- 3 Charpy V-notch perpendicular to the wall
- 4 longitudinal test piece

Figure 9 — Description of transverse and longitudinal impact test pieces

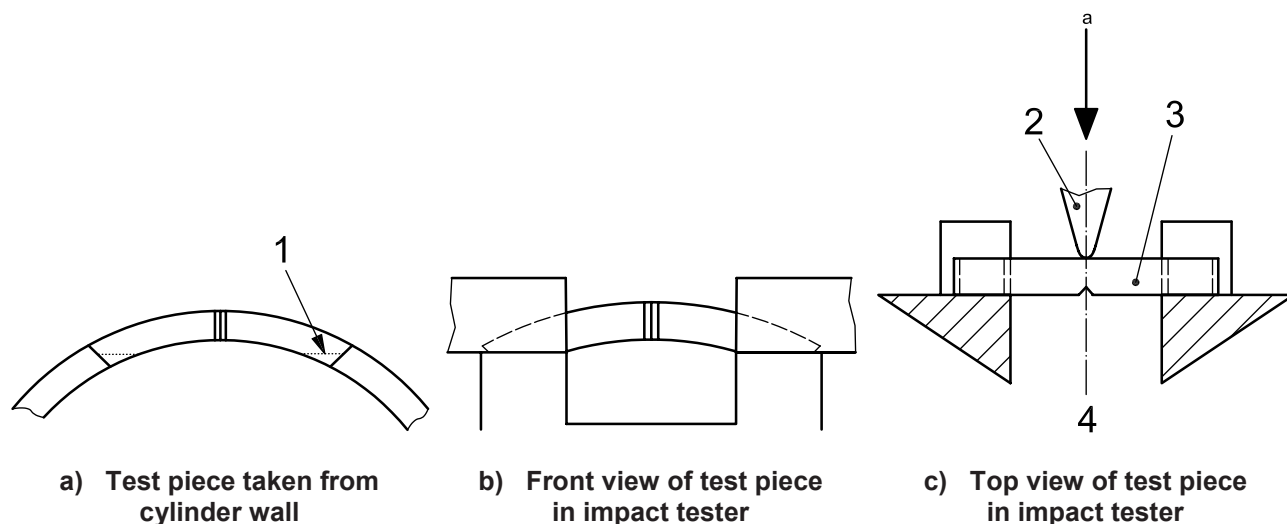

- Key**
- 1 machining optional
 - 2 striking anvil
 - 3 test piece
 - 4 centre of strike
- a Direction of strike.

Figure 10 — Description of transverse impact testing

10.4.2 Minimum acceptance values shall be as given in Table 3.

Table 3 — Impact test acceptance values

Cylinder diameter D , mm	> 140			≤ 140
Direction of testing	transverse			longitudinal
Minimum wall thickness, mm	3 to 5	> 5 to 7,5	> 7,5 to 12	3 to 6
Test temperature, °C ^a	-50			-50
Impact value ^c J/cm ²	Mean of three test pieces ^b	A ^b	B ^b	
		30	35	40
		40	50	60

^a For applications at lower temperatures, the test shall be carried out at the lowest temperature specified.

^b No individual value shall be less than 70 % of the mean value
 A-values: absolute minimum acceptance values (average of three test pieces)
 B-values: Mean values above which no flawed burst test is required as a batch test (see 10.1.2)

^c The impact value (J/cm²) is calculated by dividing the impact energy (J) by the actual cross-sectional area below the notch (cm²) of the Charpy test specimen.

10.5 Hydraulic bursting test

10.5.1 Test installation

The test equipment shall be capable of operating in accordance with the test conditions specified in 10.5.2 and of producing accurately the information specified in 10.5.3.

A typical hydraulic bursting test installation is illustrated in Figure 11.

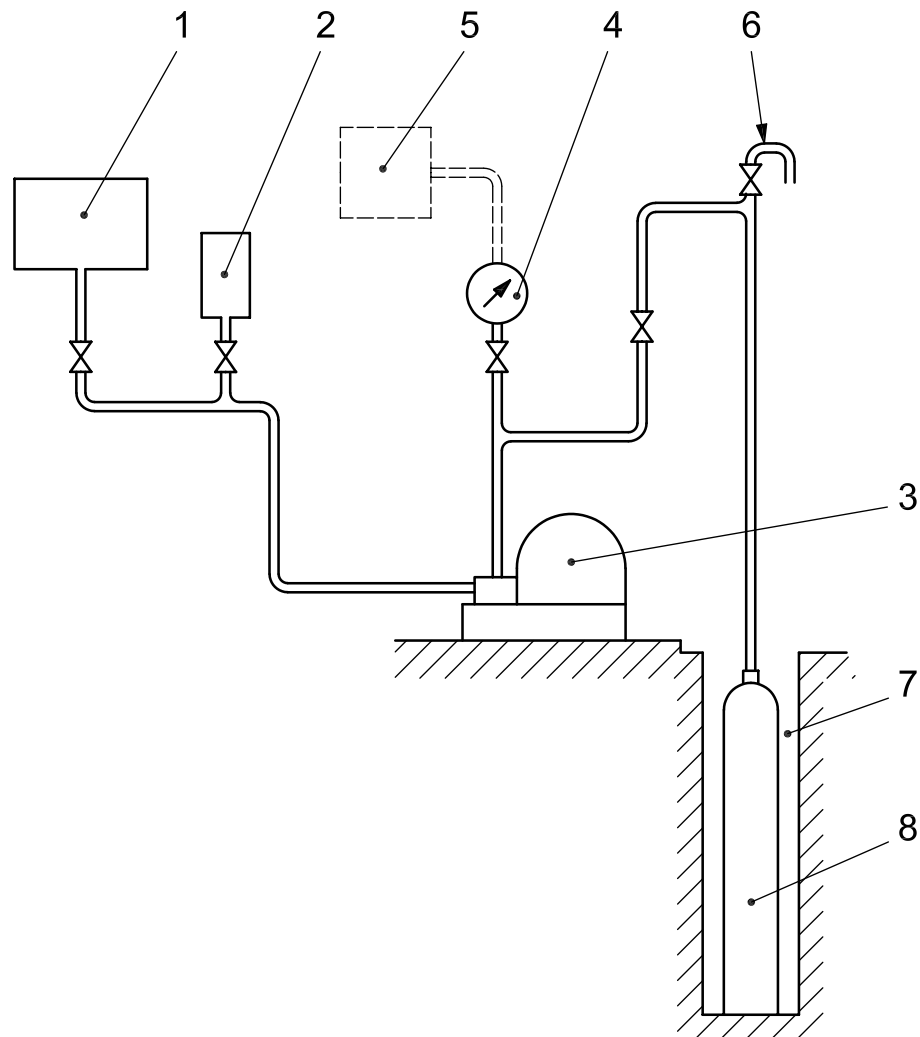

Key

- 1 test fluid reservoir
- 2 tank for measurement of test fluid (the feed tank may also be used as the measuring tank)
- 3 pump
- 4 pressure gauge
- 5 pressure/time curve recorder
- 6 vent or air release valve
- 7 test well
- 8 cylinder

Figure 11 — Typical hydraulic bursting test installation

10.5.2 Test conditions

As the cylinder and test equipment are being filled with water, care shall be taken to ensure that no air is trapped in the circuit by operating the hydraulic pump until water is discharged from the vent or air-release valve. During the test, pressurization shall be carried out in two successive stages.

- a) In the first stage, the pressure shall be increased at a rate of not more than 5 bar/s up to a pressure value corresponding to the initiation of plastic deformation.
- b) In the second stage, the pump discharge rate shall be maintained at as constant a level as is possible until the cylinder bursts.

10.5.3 Interpretation of test results

10.5.3.1 Interpretation of the burst test results shall involve:

- a) examination of the pressure/time curve or pressure/volume of water used curve, to determine the pressure at which plastic deformation of the cylinder commences, together with the bursting pressure;
- b) examination of the burst tear and of the shape of its edges.

10.5.3.2 For the results of a burst test to be considered satisfactory, the following requirements shall be met.

- a) The observed yield pressure, p_y , shall be greater than or equal to $\frac{1}{F} \times$ the test pressure, i.e. Equation (5):

$$p_y \geq \frac{1}{F} \times p_h \quad (5)$$

- b) The actual burst pressure, p_b , shall be greater than or equal to 1,6 times the test pressure, i.e. $p_b \geq 1,6 p_h$.

10.5.3.3 The cylinder shall remain in one piece and shall not fragment.

10.5.3.4 The main fracture shall be in the cylindrical portion and shall not be brittle, i.e. the fracture edges shall be inclined with respect to the wall. The tear shall not reveal a significant defect in the metal and in no case shall reach the neck. For concave bases, the tear shall not run further than the cylindrical body at the base end and, for convex bases, the tear shall not reach the centre of the base.

10.5.3.5 For cylinders with a guaranteed minimum wall thickness, a' , less than 7,5 mm, the fracture shall be acceptable only if it conforms to one of the following descriptions:

- a) longitudinal, without branching (Figure 12);
- b) longitudinal, with a side branching at each end which in no case exceeds one third of the cylinder circumference (Figure 13).

10.5.3.6 Acceptance criteria

Figure 12 and Figure 13 illustrate satisfactory burst test profiles and batches represented by such results shall be accepted.

If the configuration of the fracture does not conform to Figure 12 or Figure 13, but all other material and mechanical tests are satisfactory, investigation of the cause of the non-conformity shall be undertaken prior to acceptance or rejection of the batch.

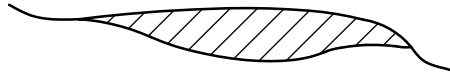

Figure 12 — Acceptable burst profiles — longitudinal without branching

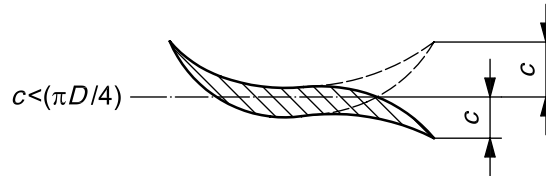

Figure 13 — Acceptable burst profiles — longitudinal with branching

11 Tests/examinations on every cylinder

11.1 General

During production, the examinations specified in 8.2 and 8.4 shall be carried out on all cylinders.

Following final heat treatment, all cylinders, except those selected for testing under Clause 10, shall be subjected to the following tests:

- a hydraulic proof pressure test in accordance with 11.2.1 or a hydraulic volumetric expansion test in accordance with 11.2. Test method requirements are given below. Additional guidance for these test methods and equipment control (calibration and maintenance) can be found in ISO 6406. The purchaser and manufacturer shall agree on which of these alternatives shall be carried out;
- a hardness test in accordance with 11.3;
- a leak test in accordance with 11.4;
- a water capacity check in accordance with 11.5.

11.2 Hydraulic test

11.2.1 Proof pressure test

The water pressure in the cylinder shall be increased at a controlled rate until the test pressure, p_h , is reached within a measuring tolerance of 0/+3 % or +10 bar, whichever is the lower.

The cylinder shall remain under pressure, p_h , for at least 30 s to establish that the pressure does not fall and that there are no leaks. During the period that the cylinder is under test pressure, it shall be visible (including the base) and remain dry. After the test, the cylinder shall show no visible permanent deformation and no trace of moisture implying leakage.

11.2.2 Volumetric expansion test

The water pressure in the cylinder shall be increased at a controlled rate until the test pressure, p_h , is reached within a measuring tolerance of 0/+3 % or +10 bar, whichever is the lower.

The cylinder shall remain under pressure, p_h , for at least 30 s and the total volumetric expansion measured. The pressure shall then be released and the volumetric expansion re-measured.

The cylinder shall be rejected if it shows a permanent expansion (i.e. volumetric expansion after the pressure has been released) in excess of 5 % of the total volumetric expansion measured at the test pressure, p_h .

The total and permanent expansion readings shall be recorded, together with the corresponding serial number of each cylinder tested, so that the elastic expansion (i.e. total expansion less permanent expansion) under the test pressure can be established for each cylinder.

11.3 Hardness test

A hardness test in accordance with ISO 6506-1 (Brinell), ISO 6508-1 (Rockwell) or other equivalent methods shall be carried out at each end of every cylinder by the manufacturer after the final heat treatment and the values recorded. The hardness values thus determined shall be within the limits established during prototype testing (see 9.2.3).

NOTE Methods for measuring the surface indentations, other than those given in ISO 6506-1 or ISO 6508-1 can be used subject to agreement between the parties concerned, provided that an equal level of accuracy can be demonstrated.

11.4 Leak test

The manufacturer shall employ such manufacturing techniques and apply such tests as will demonstrate to the satisfaction of the inspector that the cylinders do not leak.

For cylinders with base ends formed by spinning, the following are three examples of typical testing procedures:

- a pneumatic leakage test where the bottom end shall be clean and free from all moisture on the test pressure side. The inside area of the cylinder bottom surrounding the closure shall be subjected to a pressure equal to at least two thirds of the test pressure of the cylinder for a minimum of 1 min; this area shall be not less than 20 mm in diameter around the closure and at least 6% of the total bottom area. The opposite side shall be covered with water or another suitable medium and closely examined for indication of leakage. Cylinders that leak shall be rejected;
- a low pressure pneumatic test;
- a helium leak test.

11.5 Capacity check

The manufacturer shall verify that the water capacity conforms to the design drawing.

12 Certification

Each batch of cylinders shall be covered by a certificate signed by the inspector to the effect that the cylinders meet the requirements of this part of ISO 9809 in all respects. Annex D provides a typical example of a suitably worded acceptance certificate. Other formats with at least the same content are also acceptable.

Copies of the certificate shall be issued to the manufacturer. The original certificate shall be retained by the inspector and the copies by the manufacturer, in accordance with the regulations of the relevant statutory authority.

NOTE Attention is drawn to national regulations which might have additional or overriding requirements concerning the issuing and retention of certificates.

13 Marking

Each cylinder shall be permanently marked on the shoulder, or on a reinforced part of the cylinder or on a permanently fixed collar or neck ring in accordance with ISO 13769 or the relevant marking requirements of the countries of use.

NOTE Attention is drawn to requirements for marking in relevant regulations which might override the requirements given in this part of ISO 9809.

Annex A (informative)

Description and evaluation of manufacturing imperfections and conditions for rejection of seamless steel gas cylinders at time of final visual inspection by the manufacturer

A.1 General

Several types of imperfection can occur during the manufacturing of a seamless steel gas cylinder.

Such imperfections can be mechanical or material. They can be due to the basic material used, the manufacturing process, heat treatments, manipulations, necking, machining or marking operations and other circumstances during manufacture.

This annex identifies the manufacturing imperfections most commonly met and provides general information for the inspectors who perform the visual inspection. Nevertheless, extensive field experience, good judgment and independence from production are necessary for the inspector to detect and to be able to evaluate and judge an imperfection at the time of the visual inspection.

A.2 General conditions of inspection

A.2.1 It is essential to perform the visual internal and external inspection under good conditions, as follows.

- The surface of the metal, in particular of the inner wall, shall be completely clean, dry and free from oxidation products, corrosion, scale, etc., as these could obscure other more serious imperfections. Where necessary, the surface shall be cleaned under closely controlled conditions by suitable methods before further inspection.
- Appropriate sources of illumination with sufficient intensity shall be used.
- After the cylinders have been closed and the threads have been cut, the internal neck area shall be examined by means of an introscope, dental mirror or other suitable appliance.

A.2.2 Small imperfections can be removed by local dressing, grinding, machining, or other appropriate method.

Great care should be taken to avoid introducing new injurious imperfections.

After such a repair, the cylinders shall be re-examined and, if the cylindrical wall thickness is reduced, it shall be rechecked.

A.3 Manufacturing imperfections

The most commonly found manufacturing imperfections and their definitions are listed in Table A.1.

Rejection limits for repair or reject are also included in Table A.1. These rejection limits have been established following considerable field experience. They apply to all sizes and types of cylinders and service conditions. Nevertheless, some customer specifications, some types of cylinders or some special service conditions can require stronger conditions.

A.4 Rejected cylinders

- a) All rejected cylinders shall be rendered unserviceable for their original application.
- b) It may be possible to produce cylinders for different service conditions from rejected cylinders.

Table A.1 — Manufacturing imperfections

Imperfection	Description	Conditions for rejection and/or action	Repair/Reject
Bulge	Visible swelling of the wall	All cylinders with such an imperfection	Reject
Dent (flats)	A depression in the wall which has neither penetrated nor removed metal with a depth greater than 1 % of the external cylinder diameter (see Figure A.1; see also excessive grinding or machining)	— When the depth of the dent exceeds 2 % ^a of the external diameter of the cylinder	Reject
		— When the depth of the dent is greater than 1 mm and when the diameter of the dent is less than 30 times its depth ^a	Permit repair
Cut, gouge, metallic or scale impression	An impression in the wall where metal has been removed or redistributed (due basically to the introduction of foreign bodies on the mandrel or matrix during extrusion or drawing operations)	— Inside imperfection: if not superficial with sharp notches more than 5 % of wall thickness ^b	Reject
		— Outside imperfection: when the depth exceeds 5 % of the wall thickness	Repair possible (see A.2.2)
Dent containing cut or gouge	A depression in the wall which contains a cut or gouge (see Figure A.2)	All cylinders with such imperfections	Reject
Excessive grinding or machining	Local reduction of wall thickness by grinding or machining	— When the wall thickness is reduced to below the minimum design thickness	Reject
		— When it results in the formation of a dent	See dent
Rib	A longitudinal raised surface with sharp corners having a height of 3 % or more than the wall thickness (see Figure A.3)	— Inside imperfection: When height exceeds 5 % of wall thickness or when length exceeds 10 % of the length of the cylinders — Outside imperfection: When height exceeds 5 % of wall thickness or when length exceeds 5 times the thickness of the cylinders	Repair, if possible or reject (see A.2.2)
Groove	A longitudinal notch having a depth of 3 % or more than wall thickness (see Figure A.4)	— Inside imperfection: When depth exceeds 5 % of wall thickness or when length exceeds 10 % of the length of the cylinders — Outside imperfection: When depth exceeds 5 % of wall thickness or when the length exceeds 5 times the thickness of the cylinders	Repair, if possible, or reject (see A.2.2)
Lamination	Layering of the material within the cylinder wall and sometimes appearing as a discontinuity, crack lap or bulge at the surface (see Figure A.5)	— Inside imperfection: all cylinders with such imperfection	Repair, if possible, or reject
		— Outside imperfection: all cylinders with such an imperfection	Repair, if possible, or reject (see A.2.2)
Crack	Split, material separation	— When not removable within thickness tolerance	Reject
		— When removable within thickness tolerance	Repair

Table A.1 (continued)

Imperfection	Description	Conditions for rejection and/or action	Repair/Reject
Neck cracks	Appear as lines which run vertically down the thread and across the thread faces (not to be confused with tap marks = thread machining marks; see Figure A.6)	All cylinders with such imperfections	Reject
Shoulder folds and/or shoulder cracks	Folding with peaks and troughs situated in the internal shoulder area, which can propagate into the threaded area of the shoulder (see Figure A.7). Cracks can start from folds in the internal shoulder area and propagate into the cylindrical machined or threaded area of the shoulder (see Figure A.8 for exactly where shoulder cracks start and how they propagate)	— Folds or cracks which are visible as a line of oxide running into the threaded portion shall be removed by a machining operation until the lines of oxide are no longer visible (see Figure A.7). After machining, the whole area shall be re-inspected carefully and the wall thickness verified	Repair, if possible
		— If folding or lines of oxide have not been removed by machining, if cracks are always visible or if wall thickness is unsatisfactory	Reject
		— Folds which extend beyond the machined area and are clearly visible as open depressions where no oxides have been trapped into the metal, shall be accepted provided that the peaks are smooth and the root of the depression is rounded	Acceptable
Internal cracks in base	Splits in the metal of the bottom of the cylinder in star form	— When not removable within thickness tolerance	Reject
		— When removable within thickness tolerance	Repair
"Orange peel" surface	Orange peel appearance due to discontinuous metal flow	— If sharp cracks are visible in the orange peel surface	Reject
Internal neck threads damaged or out of tolerance	Neck threads damaged, with dents, cuts, burrs or out of tolerance	— When the design permits it, threads may be re-tapped and re-checked by the appropriate thread gauge and carefully visually re-examined. The appropriate number of effective threads shall be guaranteed	Repair
		— If not reparable	Reject
Pitting	Severe surface corrosion	All cylinders with such imperfections visible after shot blasting	Reject
Non-conformity with design drawing		All cylinders presenting such an imperfection	Repair if possible or reject
Neck ring not secure	Neck ring turns under application of low torque, or pulls off under low axial load (see ISO 11117)	All cylinders presenting such an imperfection	Repair possible according to approved method only
Arc or torch burns	Partial burning of the cylinder metal, the addition of weld metal or the removal of metal by scarfing or cratering	All cylinders presenting such imperfections	Reject

^a On small diameter cylinders, these general limits may have to be adjusted. Consideration of appearance also plays a part in the evaluation of dents, especially in the case of small cylinders.

^b Consideration of appearance and localisation (in thicker parts with lower stresses) can be taken into account.

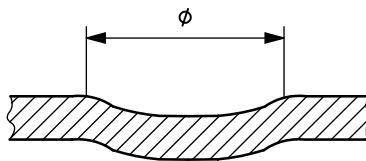

Figure A.1 — Dent

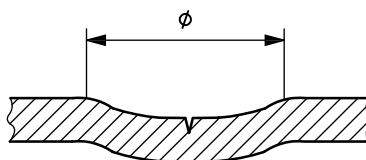

Figure A.2 — Dent containing cut or gouge

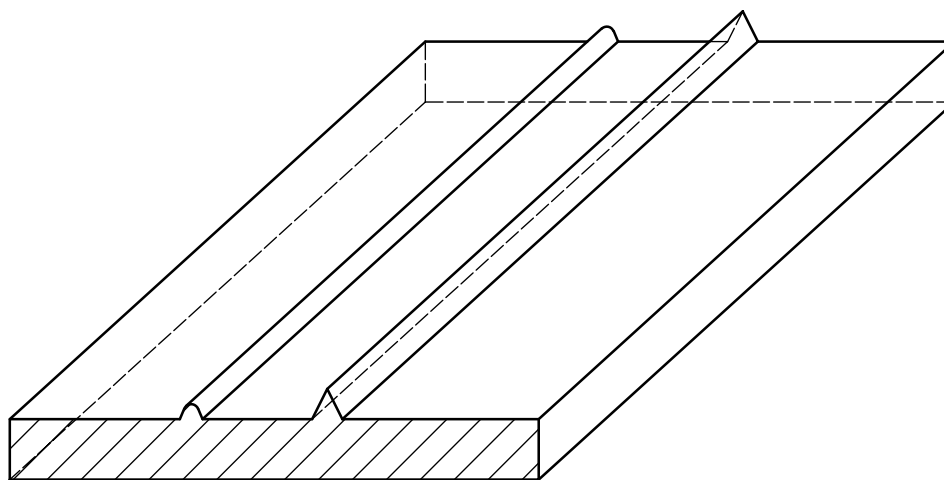

Figure A.3 — Rib

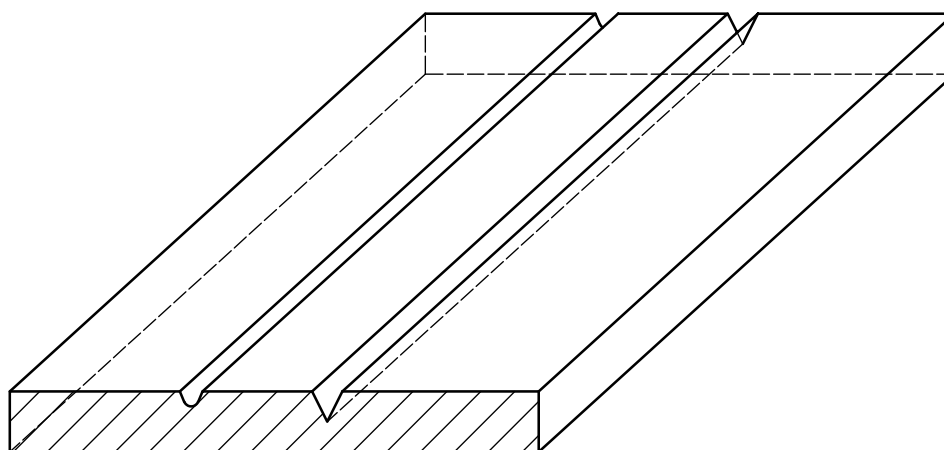

Figure A.4 — Groove

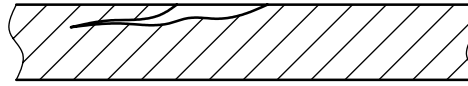
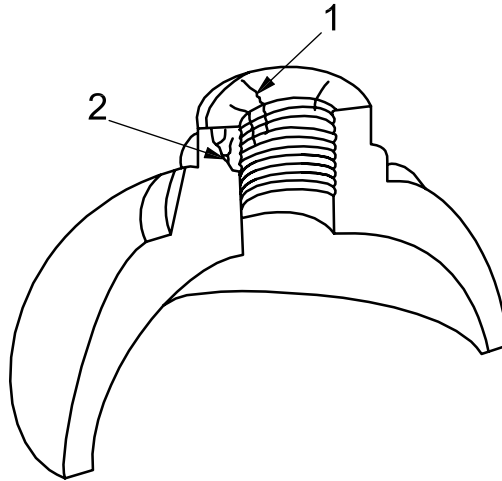

Figure A.5 — Lamination



Key

- 1 neck cracks
- 2 propagated cracks in the neck

Figure A.6 — Neck cracks

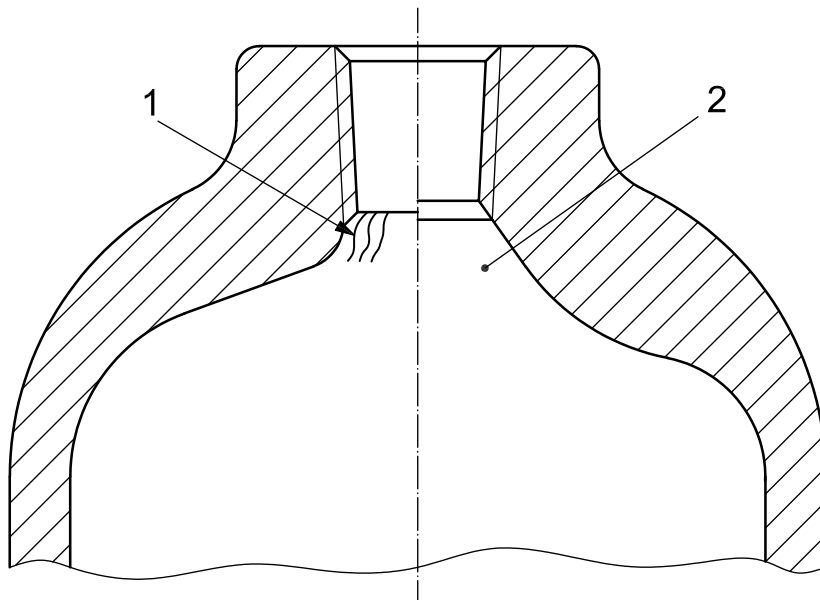

Key

- 1 folds or cracks
- 2 after machining

Figure A.7 — Cylinder shoulder folds or cracks before and after machining

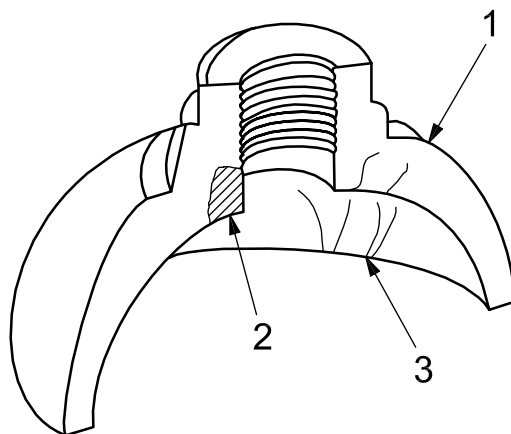

Key

- 1 shoulder cracks
- 2 fold
- 3 propagated cracks in the shoulder

Figure A.8 — Shoulder cracks

Annex B (normative)

Ultrasonic examination

B.1 General

This annex is based on techniques used by cylinder manufacturers. Other techniques of ultrasonic examination may be used, provided that these have been demonstrated to be suitable for the manufacturing method.

B.2 General requirements

The ultrasonic examination equipment shall be capable of at least detecting the reference standard notches as described in B.3.2. It shall be serviced regularly in accordance with the manufacturer's operating instructions to ensure that its accuracy is maintained. Inspection records and approval certificates for the equipment shall be maintained.

The operation of the test equipment shall be by qualified and experienced personnel certified at least to Level 1 and supervised by personnel certified at least to Level 2 in accordance with ISO 9712. Other standards which meet or exceed these minimum requirements may be used subject to approval by the inspector.

The inner and outer surfaces of any cylinder which is to be tested ultrasonically shall be in a condition suitable for an accurate and reproducible examination.

For flaw detection the pulse echo system shall be used to detect flaws such as cracks and folds, etc. For thickness measurement, either the resonance method or the pulse echo system shall be used. Either contact or immersion techniques of examination shall be used.

A coupling method which ensures adequate transmission of ultrasonic energy between the test probe and the cylinder shall be used.

B.3 Flaw detection of the cylindrical parts

B.3.1 Procedure

The cylinders to be examined and the search unit shall have a rotating motion and translation relative to one another such that a helical scan of the cylinder will be described. The velocity of rotation and translation shall be constant within $\pm 10\%$. The pitch of the helix shall be less than the width covered by the probe (at least a 10% overlapping shall be guaranteed) and be related to the effective beam width such as to ensure 100% coverage at the velocity of rotation and translation used during the calibration procedure.

An alternative scanning method may be used for transverse detection of imperfections, in which the scanning or relative movement of the probes and the work piece is longitudinal, the sweeping motion being such as to ensure a 100% surface coverage with approximately 10% overlapping of the sweeps.

The cylinder wall shall be examined for longitudinal imperfections with the ultrasonic energy transmitted in both circumferential directions and for transverse imperfections in both longitudinal directions.

For concave based cylinders, the transition region between the cylindrical part and cylinder base shall also be examined for transverse imperfections in the direction of the base. For the area to be considered, see Figure B.1.

In this case, or when optional examination is carried out on the transition areas between the wall and neck and/or wall and base, this may be conducted manually if not carried out automatically.

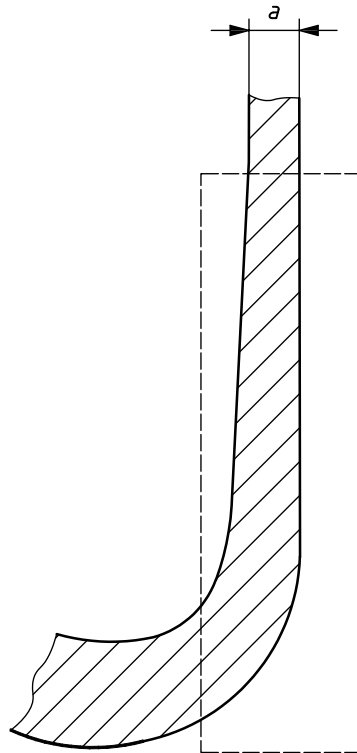

Figure B.1 — Base/wall transition region

One of the following two methods shall be used:

— Method A:

The ultrasonic sensitivity shall be set at + 6 dB to improve the detection of imperfections equivalent to 5 % of the cylindrical wall thickness in this thickened portion.

— Method B:

The ultrasonic system shall be calibrated using a standard reference artefact of a cylinder with a notch at sidewall-to-base transition (SBT) area shown in Figure B.2.

The depth of notch, T , for SBT shall be $(10 \pm 1) \%$ of the guaranteed minimum wall thickness, a' , with a minimum of 0,2 mm and maximum of 1 mm, over the full length of the notch.

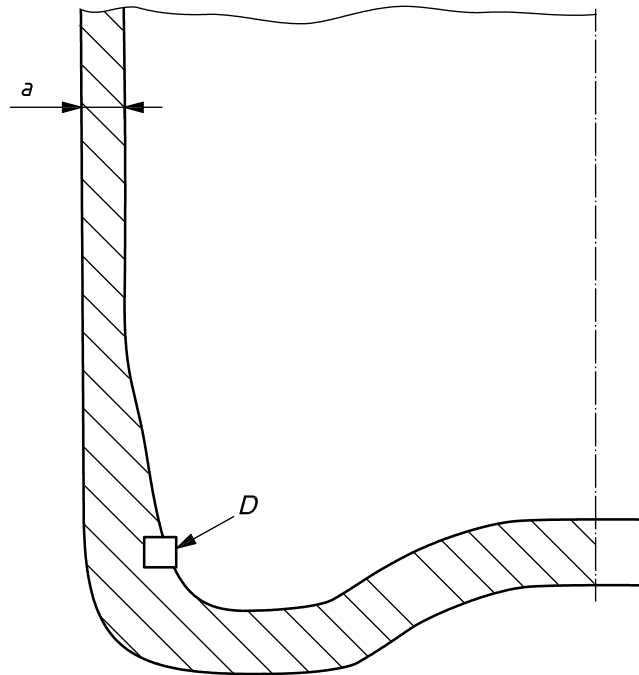

Key

- D* approximate notch location
- a* guaranteed minimum wall thickness, a'

Figure B.2 — Schematic representation of reference notch for SBT

The effectiveness of the equipment shall be periodically checked by putting a reference standard through the examination procedure. This check shall be carried out at least at the beginning and end of each shift. If during this check, the presence of the appropriate reference notch is not detected, all cylinders examined subsequent to the last acceptable check shall be re-examined after the equipment has been reset.

B.3.2 Reference standard

A reference standard of convenient length shall be prepared from a cylinder which is dimensionally and acoustically representative of the cylinder to be examined, as demonstrable by the manufacturer. The reference standard shall be free of discontinuities which may interfere with the detection of the reference notches.

Reference notches, both longitudinal and transverse, shall be machined on the outer and inner surface of the standard. The notches shall be separated such that each notch can be clearly identified.

Dimensions and shape of notches are of crucial importance for the adjustment of the equipment (see Figures B.3 and B.4).

- The length of the notches, E , shall be not greater than 50 mm.
- The width, W , shall be not greater than twice the nominal depth, T . However, where this condition cannot be met a maximum width of 1,0 mm is acceptable.
- The depth of the notches, T , shall be $(5 \pm 0,75) \%$ of the guaranteed minimum wall thickness, a' , with a minimum of 0,2 mm and a maximum of 1,0 mm over the full length of the notch. Runouts at each end are permissible.

- The notch shall be sharp edged at its intersection with the surface of the cylinder wall. The cross-section of the notch shall be rectangular except where spark erosion machining methods are employed, when it is acknowledged that the bottom of the notch will be rounded.
- The shape and dimensions of the notch shall be demonstrated by an appropriate method.

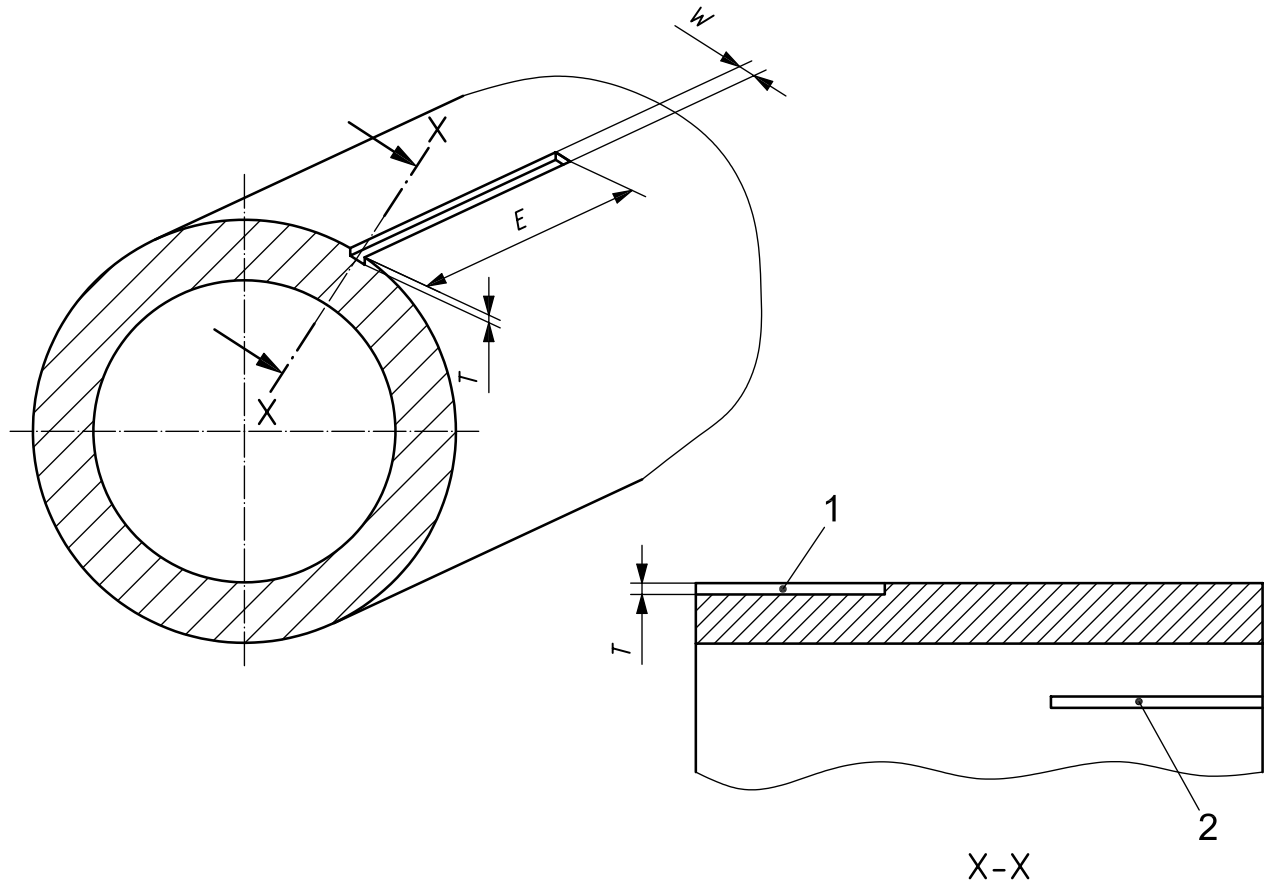

NOTE $T = (5 \pm 0,75) \% a'$ but ≤ 1 mm and $\geq 0,2$ mm; $W \leq 2T$, but if not possible, ≤ 1 mm, $E \leq 50$ mm.

Key

- 1 outside reference notch
- 2 inside reference notch

Figure B.3 — Design details and dimensions of the reference notches for longitudinal imperfections

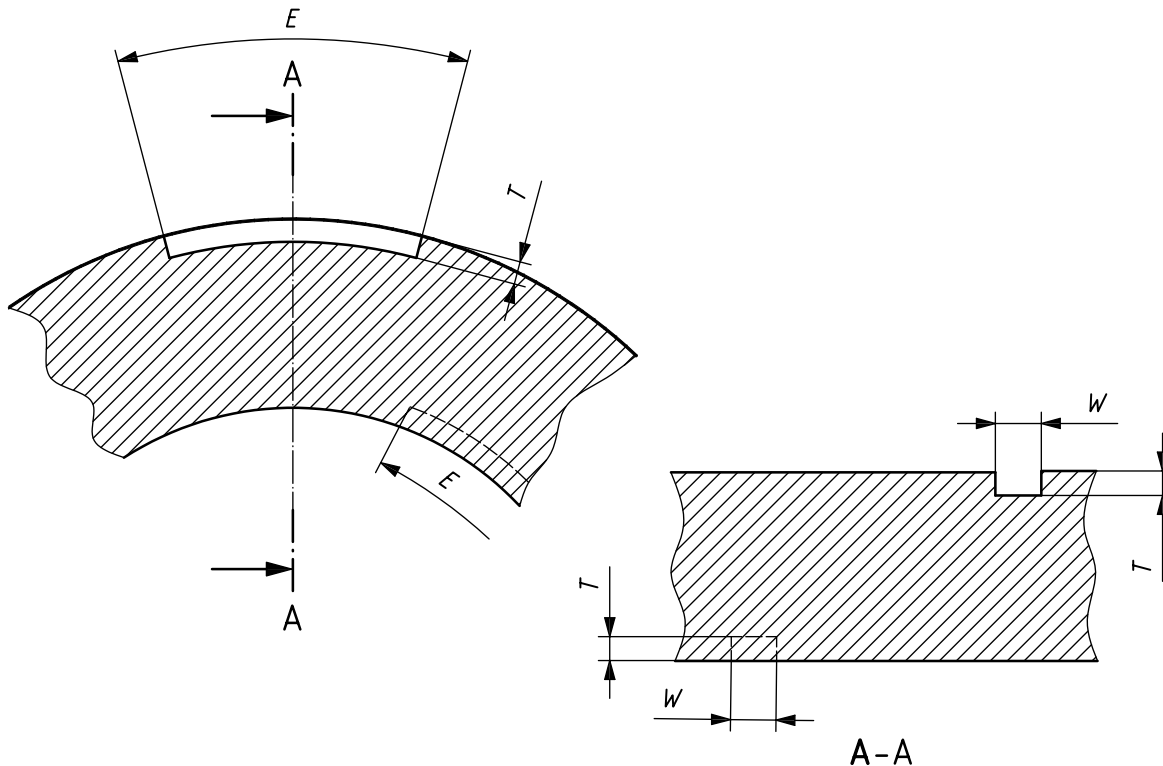

NOTE $T = (5 \pm 0,75) \% a'$ but ≤ 1 mm and $\geq 0,2$ mm; $W \leq 2T$, but if not possible, ≤ 1 mm, $E \leq 50$ mm.

Figure B.4 — Schematic representation of the reference notches for circumferential imperfections

B.3.3 Calibration of equipment

Using the reference standard described in B.3.2, the equipment shall be adjusted to produce clearly identifiable indications from inner and outer surface notches. The amplitude of the indications shall be as near equal as possible. If it is not possible to set the rejection levels individually, then the indication of smallest amplitude shall be used as the rejection level and for setting visual, audible, recording or sorting devices. The equipment shall be calibrated with the reference standard or probe, or both, moving in the same manner, in the same direction and at the same speed as will be used during the inspection of the cylinder. All visual, audible, recording or sorting devices shall operate satisfactorily at the test speed.

B.4 Wall thickness measurement

If the measurement of the wall thickness is not carried out in another stage of production, the cylindrical part shall be 100 % examined to ensure that the thickness is not less than the guaranteed minimum value.

B.5 Interpretation of results

Cylinders with indications that are equal to or greater than the lowest of the indications from the reference notches shall be withdrawn. This comparison shall be made between the indications from the cylinder and those from the reference notch in the same orientation and on the same face e.g. a transverse inside imperfection shall be compared with the transverse inside reference notch. The cause of the indication shall be identified and, if possible, removed; after removal the cylinders shall be re-subjected to ultrasonic flaw detection and thickness measurement.

Occasionally, a below minimum wall thickness indication can result due to the presence of a sub-surface imperfection (e.g. internal lamination) at the point. In such cases the extent of the imperfection shall be evaluated.

Any cylinder which is shown to be below the guaranteed minimum thickness shall be rejected.

B.6 Certification

The ultrasonic examination shall be certified by the cylinder manufacturer.

Every cylinder that has passed the ultrasonic testing in accordance with this specification shall be permanently marked with the characters "UT", or with the symbol shown as an example in Figure B.5 (where the characters "XY" represent the manufacturer's logo or symbol).

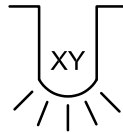

Figure B.5 — UT symbol

Annex C
(informative)

Type approval certificate

TYPE APPROVAL CERTIFICATE No.....

Issued by

(Inspector)

.....
applicable International Standard

concerning

SEAMLESS STEEL GAS CYLINDERS

Approval No. Date

Type of cylinder

(Description of the family of cylinders [Drawing No.] which has received type approval)

p_h : bar D : mm d' : mm

Shape of base: Min. base thickness: mm

Overall length (min., max.): min. mm, max. mm

V (min., max.): min. l, max. l

Material and heat treatment:

Material characteristics: R_{eg} : MPa R_{mg} : MPa

Manufacturer or agent:

(Name and address of manufacturer or its agent)

Reference to prototype test report(s):

All information may be obtained from

Results and conclusions

(Name and address of approving body)

.....
Date Place

.....
(Signature of Inspector)

ACCEPTANCE TESTS

1. Measurements taken on one representative cylinder of the batch⁴⁾

Test No. or Batch No. or Cylinder No.	Cast No.	Water capacity [l]	Mass empty [kg]	Min. measured thickness [mm]	
				wall	base

2. Mechanical tests⁴⁾

Test No.	Cast No.	Tensile test			Hardness	Bend or flattening test	Impact test		Burst test			
		Yield strength R_{ea} [MPa]	Tensile strength R_{ma} [MPa]	Elongation A [%]			180° without cracking	Charpy V at ...°C		p_y [bar]	p_b [bar]	failure mode
								Direction:				
							Avg. [J/cm ²]	Min. [J/cm ²]				
Min. values:												

3. Ultrasonic examination:

required (yes/no)¹⁾: passed (yes/no)¹⁾:

This is to certify that the cylinders covered by this Acceptance Certificate have passed the hydraulic pressure test and all the other tests as required in Clause 10 of ISO 9809-.... and they are in full accordance with this part of ISO 9809 and the certified design type approval.

Special remarks:

On behalf of:

Date:

.....

(Signature of Inspector)

- 1) Delete as applicable.
- 2) If required by the customer.
- 3) To be quoted or drawing to be attached.
- 4) Need not be filled in if test reports are attached.

Bibliography

- [1] ISO 6406, *Gas cylinders — Seamless steel gas cylinders — Periodic inspection and testing*
- [2] ISO 10286, *Gas cylinders — Terminology*
- [3] ISO 11114-4, *Transportable gas cylinders — Compatibility of cylinder and valve materials with gas contents — Part 4: Test methods for selecting metallic materials resistant to hydrogen embrittlement*
- [4] ISO 11116-1, *Gas cylinders — 17E taper thread for connection of valves to gas cylinders — Part 1: Specifications*
- [5] ISO 11116-2, *Gas cylinders — 17E taper thread for connection of valves to gas cylinders — Part 2: Inspection gauges*
- [6] ISO 11117, *Gas cylinders — Valve protection caps and valve guards — Design, construction and tests*
- [7] ISO 11191, *Gas cylinders — 25E taper thread for connection of valves to gas cylinders — Inspection gauges*
- [8] ISO/TR 12391-1, *Gas cylinders — Refillable seamless steel — Performance tests — Part 1: Philosophy, background and conclusions*
- [9] ISO/TR 12391-2, *Gas cylinders — Refillable seamless steel — Performance tests — Part 2: Fracture performance tests — Monotonic burst tests*
- [10] ISO/TR 12391-3, *Gas cylinders — Refillable seamless steel — Performance tests — Part 3: Fracture performance tests — Cyclical burst tests*
- [11] ISO/TR 12391-4, *Gas cylinders — Refillable seamless steel — Performance tests — Part 4: Flawed-cylinder cycle test*
- [12] ISO 13341, *Transportable gas cylinders — Fitting of valves to gas cylinders*
- [13] EN 473, *Non-destructive testing — Qualification and certification of NDT personnel — General principles*
- [14] ST/SG/AC.10/1/Rev. 13, *Recommendations on the Transport of Dangerous Goods: Model Regulations*. Vols. 1 and 2

BSI - British Standards Institution

BSI is the independent national body responsible for preparing British Standards. It presents the UK view on standards in Europe and at the international level. It is incorporated by Royal Charter.

Revisions

British Standards are updated by amendment or revision. Users of British Standards should make sure that they possess the latest amendments or editions.

It is the constant aim of BSI to improve the quality of our products and services. We would be grateful if anyone finding an inaccuracy or ambiguity while using this British Standard would inform the Secretary of the technical committee responsible, the identity of which can be found on the inside front cover. Tel: +44 (0)20 8996 9000. Fax: +44 (0)20 8996 7400.

BSI offers members an individual updating service called PLUS which ensures that subscribers automatically receive the latest editions of standards.

Buying standards

Orders for all BSI, international and foreign standards publications should be addressed to Customer Services. Tel: +44 (0)20 8996 9001. Fax: +44 (0)20 8996 7001 Email: orders@bsigroup.com You may also buy directly using a debit/credit card from the BSI Shop on the Website <http://www.bsigroup.com/shop>

In response to orders for international standards, it is BSI policy to supply the BSI implementation of those that have been published as British Standards, unless otherwise requested.

Information on standards

BSI provides a wide range of information on national, European and international standards through its Library and its Technical Help to Exporters Service. Various BSI electronic information services are also available which give details on all its products and services. Contact Information Centre. Tel: +44 (0)20 8996 7111 Fax: +44 (0)20 8996 7048 Email: info@bsigroup.com

Subscribing members of BSI are kept up to date with standards developments and receive substantial discounts on the purchase price of standards. For details of these and other benefits contact Membership Administration. Tel: +44 (0)20 8996 7002 Fax: +44 (0)20 8996 7001 Email: membership@bsigroup.com

Information regarding online access to British Standards via British Standards Online can be found at <http://www.bsigroup.com/BSOL>

Further information about BSI is available on the BSI website at <http://www.bsigroup.com>.

Copyright

Copyright subsists in all BSI publications. BSI also holds the copyright, in the UK, of the publications of the international standardization bodies. Except as permitted under the Copyright, Designs and Patents Act 1988 no extract may be reproduced, stored in a retrieval system or transmitted in any form or by any means – electronic, photocopying, recording or otherwise – without prior written permission from BSI.

This does not preclude the free use, in the course of implementing the standard, of necessary details such as symbols, and size, type or grade designations. If these details are to be used for any other purpose than implementation then the prior written permission of BSI must be obtained.

Details and advice can be obtained from the Copyright and Licensing Manager. Tel: +44 (0)20 8996 7070 Email: copyright@bsigroup.com