

Plastics — Determination of burning behaviour of thin flexible vertical specimens in contact with a small-flame ignition source

The European Standard EN ISO 9773:1998, with the incorporation of amendment A1:2003, has the status of a British Standard

ICS 13.220.40; 83.080.01

National foreword

This British Standard is the official English language version of EN ISO 9773:1998, including amendment A1:2003. It is identical with ISO 9773:1998, including amendment 1:2003. It supersedes BS 2782-1: Method 140B:1993 which is withdrawn.

The UK participation in its preparation was entrusted to Technical Committee PRI/26, Burning behaviour of plastics and rubbers, which has the responsibility to:

- aid enquirers to understand the text;
- present to the responsible international/European committee any enquiries on the interpretation, or proposals for change, and keep the UK interests informed;
- monitor related international and European developments and promulgate them in the UK.

A list of organizations represented on this committee can be obtained on request to its secretary.

Cross-references

The British Standards which implement international or European publications referred to in this document may be found in the *BSI Catalogue* under the section entitled “International Standards Correspondence Index”, or by using the “Search” facility of the *BSI Electronic Catalogue* or of British Standards Online.

This publication does not purport to include all the necessary provisions of a contract. Users are responsible for its correct application.

Compliance with a British Standard does not of itself confer immunity from legal obligations.

Summary of pages

This document comprises a front cover, an inside front cover, the EN ISO title page, the EN ISO foreword page, the ISO title page, page ii, pages 1 to 12, an inside back cover and a back cover.

The BSI copyright notice displayed in this document indicates when the document was last issued.

This British Standard, having been prepared under the direction of the Sector Committee for Materials and Chemicals, was published under the authority of the Standards Committee and comes into effect on 15 March 1999

© BSI 21 October 2004

Amendments issued since publication

Amd. No.	Date	Comments
14881 Corrigendum No. 1	3 December 2003	Incorporating corrected EN ISO foreword page
15375	21 October 2004	Changes to Clauses 1, 2 and 7 and change to Table A.1

ICS 13.220.40; 83.080.01

Descriptors: see ISO document

English version

Plastics — Determination of burning behaviour of thin flexible vertical specimens in contact with a small-flame ignition source —

(includes amendment A1:2003)
(ISO 9773:1998 + A1:2003)

Plastiques — Détermination du comportement au feu d'éprouvettes minces verticales souples au contact d'une petite flamme comme source d'allumage
(inclut l'amendement A1:2003)
(ISO 9773:1998 + A1:2003)

Kunststoffe — Bestimmung des Brandverhaltens von dünnen, biegsamen, vertikal ausgerichteten Probekörpern in Kontakt mit einer kleinen Zündquelle —
(enthält Änderung A1:2003)
(ISO 9773:1998 + A1:2003)

This European Standard was approved by CEN on 1 March 1998.
Amendment A1 was approved by CEN on 24 July 2003.

CEN members are bound to comply with the CEN/CENELEC Internal Regulations which stipulate the conditions for giving this European Standard the status of a national standard without any alteration. Up-to-date lists and bibliographical references concerning such national standards may be obtained on application to the Central Secretariat or to any CEN member.

This European Standard exists in three official versions (English, French, German). A version in any other language made by translation under the responsibility of a CEN member into its own language and notified to the Central Secretariat has the same status as the official versions.

CEN members are the national standards bodies of Austria, Belgium, Czech Republic, Denmark, Finland, France, Germany, Greece, Hungary, Iceland, Ireland, Italy, Luxembourg, Malta, Netherlands, Norway, Portugal, Slovakia, Spain, Sweden, Switzerland and United Kingdom.

CEN

European Committee for Standardization
Comité Européen de Normalisation
Europäisches Komitee für Normung

Management Centre: rue de Stassart 36, B-1050 Brussels

Foreword

The text of the International Standard ISO 9773:1998 has been developed by Technical Committee ISO/TC 61, Plastics, in collaboration with Technical Committee CEN/TC 249, Plastics, the Secretariat of which is held by IBN.

The European Standard shall be given the status of a national standard, either by publication of an identical text or by endorsement, at the latest by September 1998, and conflicting national standards shall be withdrawn at the latest by September 1998.

According to the CEN/CENELEC Internal Regulations, the national standards organizations of the following countries are bound to implement this European Standard: Austria, Belgium, Czech Republic, Denmark, Finland, France, Germany, Greece, Iceland, Ireland, Italy, Luxembourg, Netherlands, Norway, Portugal, Spain, Sweden, Switzerland and the United Kingdom.

Endorsement notice

The text of the International standard ISO 9773:1998 has been approved by CEN as a European Standard without modification.

Foreword to amendment A1

This document EN ISO 9773:1998/A1:2003 has been prepared by Technical Committee ISO/TC 61, Plastics, in collaboration with Technical Committee CEN/TC 249, Plastics, the Secretariat of which is held by IBN.

This European Standard shall be given the status of a national standard, either by publication of an identical text or by endorsement, at the latest by March 2004, and conflicting national standards shall be withdrawn at the latest by March 2004.

According to the CEN/CENELEC Internal Regulations, the national standards organizations of the following countries are bound to implement this European Standard: Austria, Belgium, Czech Republic, Denmark, Finland, France, Germany, Greece, Hungary, Iceland, Ireland, Italy, Luxembourg, Malta, Netherlands, Norway, Portugal, Slovakia, Spain, Sweden, Switzerland and the United Kingdom.

Endorsement notice

The text of ISO 9773:1998 has been approved by CEN as EN ISO 9773:1998/A1:2003 without any modifications.

INTERNATIONAL
STANDARD

ISO
9773

Second edition
1998-03-01

AMENDMENT 1
2003-09-15

**Plastics — Determination of burning
behaviour of thin flexible vertical
specimens in contact with a small-flame
ignition source**

*Plastiques — Détermination du comportement au feu d'éprouvettes minces
verticales souples au contact d'une petite flamme comme source
d'allumage*



Foreword

ISO (the International Organization for Standardization) is a worldwide federation of national standards bodies (ISO member bodies). The work of preparing International Standards is normally carried out through ISO technical committees. Each member body interested in a subject for which a technical committee has been established has the right to be represented on that committee. International organizations, governmental and non-governmental, in liaison with ISO, also take part in the work. ISO collaborates closely with the International Electrotechnical Commission (IEC) on all matters of electrotechnical standardization.

Draft International Standards adopted by the technical committees are circulated to the member bodies for voting. Publication as an International Standard requires approval by at least 75 % of the member bodies casting a vote.

International Standard ISO 9773 was prepared by Technical Committee ISO/TC 61, *Plastics*, Subcommittee SC 4, *Burning behaviour*.

This second edition cancels and replaces the first edition (ISO 9773:1990) which has been technically revised.

Annex A of this International Standard is for information only.

Descriptors: plastics, flexible plastics, tests, fire tests, flammability testing.

Plastics - Determination of burning behaviour of thin flexible vertical specimens in contact with a small-flame ignition source

1. Scope

1.1 This International Standard specifies a small-scale laboratory screening procedure for comparing the relative burning behaviour of vertically oriented thin and relatively flexible plastics specimens exposed to a low-energy-level flame ignition source. These specimens cannot be tested using method B of IEC 60695-11-10:1999 since they distort or shrink away from the applied flame source without igniting.

1.2 This method of test determines the afterflame and afterglow times of specimens.

1.3 The classification system described in annex A is intended for quality control and the preselection of component materials for products. The classification established by this method of test is applicable only to the material used for the specimens.

NOTE 1 - Test results are influenced by material components, e.g. pigments, fillers, fire-retardant concentrations.

2. Normative references

The following standards contain provisions which, through reference in this text, constitute provisions of this International Standard. At the time of publication, the editions indicated were valid. All standards are subject to revision, and parties to agreements based on this International Standard are encouraged to investigate the possibility of applying the most recent editions of the standards indicated below. Members of IEC and ISO maintain registers of currently valid International Standards.

ISO 291:1997, *Plastics — Standard atmospheres for conditioning and testing*.

ISO 1043-1:2001, *Plastics — Symbols and abbreviated terms — Basic polymers and their special characteristics*.

IEC 60695-11-10:1999, *Fire hazard testing — Test flames — 50 W horizontal and vertical flame test methods*.

ISO 5725-2:1994, *Accuracy (trueness and precision) of measurement methods and results — Part 2: Basic method for the determination of repeatability and reproducibility of a standard measurement method*.

ISO 10093:1998, *Plastics — Fire tests — Standard ignition sources*.

ASTM D 5207-98, *Standard practice for the calibration of 20 mm and 125 mm test flames for small-scale burning tests on plastic materials.* "

3. Definitions

For the purposes of this International Standard, the following definitions apply:

- 3.1 afterflame:** A flame which, under specified test conditions, persists after the ignition source has been removed.
- 3.2 afterflame time:** The length of time for which an afterflame persists.
- 3.3 afterglow:** Persistence of glowing of a material, under specified test conditions, after cessation of flaming or, if no flaming occurs, after the ignition source has been removed.
- 3.4 afterglow time:** The length of time for which an afterglow persists.

4. Principle

A test specimen having a nearly cylindrical form is supported vertically by one end and the free end is exposed to two successive applications of a specified gas flame. The burning behaviour of the specimen is assessed by measuring the afterflame and/or afterglow time,

5. Significance of test

- 5.1** Tests made on a material under the conditions specified in this standard can be of considerable value when comparing the relative burning behaviour of different materials, controlling manufacturing processes or assessing any change in burning characteristics prior to, or during, use. The results obtained from this method are dependent upon the shape, orientation and insulation of the specimen and the conditions of ignition. Correlation with performance under actual service conditions is not implied.
- 5.2** Results obtained in accordance with this standard shall not be used to describe or appraise the fire hazard presented by a particular material or shape under actual fire conditions. Assessment for fire hazard requires consideration of such factors as: fuel contribution, intensity of burning (rate of heat release), products of combustion and environmental factors such as the intensity of source, orientation of exposed material and ventilation conditions.
- 5.3** Burning behaviour as measured by this test method is affected by such factors as density, colour and anisotropy of the material and thickness of the specimen.
- 5.4** The effects on the burning behaviour of additives, deterioration, and possible loss of volatile components are measurable using this method. Results obtained using this method may serve for comparing the relative performance of materials and can be helpful in material assessment.
- 5.5** The burning behaviour of some plastic materials may change with time. It is accordingly advisable to make tests before and after oven conditioning by an appropriate procedure that is described in the test report. The preferred oven conditioning conditions shall be 7 days at 70°C. However, other oven conditioning times and temperatures may be used if agreed to by all parties.

6. Apparatus and materials

6.1 Laboratory fume hood (cupboard), having an internal volume of at least $0,5 \text{ m}^3$, which shall be used when testing the specimens. The chamber shall permit observation and shall be draught free while permitting normal thermal circulation of air past the specimen during burning. For safety and convenience, it is desirable that this enclosure (which can be completely closed) be fitted with an evacuation device, such as an exhaust fan, to remove products of combustion which may be toxic. However, it is important to turn off the device during the actual test and to start it again immediately after the test to remove the products of combustion.

6.2 Laboratory burner, as described in ISO 10093 as ignition source P/PF2 (50 W source), having a barrel length of $100 \text{ mm} \pm 10 \text{ mm}$ and an inside diameter of $9,5 \text{ mm} \pm 0,3 \text{ mm}$. The barrel shall not be equipped with an end attachment such as a stabilizer. The burner shall be calibrated in accordance with ASTM D 5207.

6.3 Ring stand, with clamps or the equivalent, adjustable for positioning of the specimen.

6.4 Timing device, accurate to 0,5 s in one hour with a resolution of 0,1 s.

6.5 Measuring scale, graduated in millimetres.

6.6 Supply of technical-grade methane gas, of minimum purity 98 %, with regulator and meter for uniform gas flow.

NOTE 2 - Other gas mixtures having a heat content of $37 \text{ MJ/m}^3 \pm 1 \text{ MJ/m}^3$ have been found to provide similar results. However, technical-grade methane, having a minimum purity of 98 percent, shall be used in cases of dispute.

6.7 Desiccator, containing a suitable drying agent, capable of maintaining a relative humidity not exceeding 20 % at $23^\circ\text{C} \pm 2^\circ\text{C}$.

6.8 Conditioning room or chamber, capable of being maintained at $23^\circ\text{C} \pm 2^\circ\text{C}$ and a relative humidity of $(50 \pm 5) \%$ as specified in ISO 291.

6.9 Micrometer, capable of being read to 0,01 mm,

6.10 Specimen mandrel form, made from $13 \text{ mm} \pm 0,5 \text{ mm}$ diameter rod.

6.11 Pressure-sensitive adhesive tape, of a commercially available type.

6.12 Stainless steel or nichrome wire, of diameter 0,2 mm to 0,5 mm.

6.13 Absorbent 100 % cotton wool.

6.14 Air-circulating oven, capable of being maintained at $70^\circ\text{C} \pm 2^\circ\text{C}$ with a minimum of five air changes/hour.

6.15 Weighing scale or balance, having an accuracy and resolution of 0,01 g.

7 Specimens

7.1 It is possible that the results of tests carried out on test specimens taken from materials of different densities, colours, thicknesses, melt flow abilities and directions of anisotropy, or with different additive or filler/reinforcement contents, will be different. For materials with properties or compositions which vary over a range, the test specimens shall be representative of the whole range.

7.2 Test specimens with densities, melt flow abilities and additive or filler/reinforcement contents at the extremes of the range shall be tested and, if the test results yield the same flame test classification, all specimens within the range shall be considered representative of the range. If the burning characteristics are not essentially the same, the results of the evaluation shall be considered to apply only to the materials with the densities, melt flow abilities and additive or filler/reinforcement contents tested. Additional test specimens with intermediate densities, melt flow abilities and additive or filler/reinforcement contents shall be tested to determine the range of applicability.

7.3 Uncoloured test specimens and test specimens with the highest level of organic and inorganic pigment loading shall be tested and, if the test results yield the same flame test classification, all specimens with this colour range shall be considered representative of the range. If a material contains pigments which are known to affect the flammability characteristics, specimens containing these pigments shall also be tested. Thus the test specimens tested shall be those that

- a) contain no colouring;
- b) contain the highest level of organic pigments;
- c) contain the highest level of inorganic pigments;
- d) contain pigments which are known to adversely affect flammability characteristics.

7.4 All specimens shall be cut from a representative sample of the material (sheets or end products). After any cutting operation, care shall be taken to remove all dust and any particles from the surface. Cut edges shall have a smooth finish.

7.5 The standard test specimen shall be $200 \text{ mm} \pm 5 \text{ mm}$ long, $50 \text{ mm} \pm 2 \text{ mm}$ wide and a maximum of $0,25 \text{ mm}$ thick. Measure the thickness of each to the nearest $0,01 \text{ mm}$ and note the measurements.

NOTE 3 Tests made on test specimens of different thicknesses or directions of anisotropy may not be comparable.

7.6 Mark each specimen across its width with a line at $125 \text{ mm} \pm 5 \text{ mm}$ from one end (the bottom end). Wrap the longitudinal axis of the specimen tightly around the longitudinal axis of the mandrel to form a lapped cylinder with the 125 mm line exposed. Secure the overlapping portions of the specimen within the upper 75 mm segment above the 125 mm mark and at the upper end of the tube with pressure-sensitive adhesive tape. Then remove the mandrel.

NOTE 4 For stiff specimens, the pressure-sensitive tape may be reinforced or replaced by nichrome wire wound around the top 75 mm of the specimen (see Figure 1).

7.7 Prepare a minimum of 20 specimens. It is advisable to prepare additional specimens for any retesting which may be necessary.

8. Conditioning

Unless otherwise required by the material specifications, conditioning and testing shall be carried out under the following conditions:

8.1 Two sets of five specimens shall be preconditioned for at least 48 h at $23^{\circ}\text{C} \pm 2^{\circ}\text{C}$ and $(50 \pm 5) \%$ relative humidity. Testing shall be carried out in the laboratory atmosphere (see 9.1) within one hour of being conditioned.

8.2 Two sets of five specimens shall be preconditioned for 168 h at $70^{\circ}\text{C} \pm 1^{\circ}\text{C}$ and then cooled in a desiccator for at least 4 h at room temperature, prior to testing. Once removed from the desiccator, the specimens shall be tested in the laboratory atmosphere (see 9.1) within one hour.

9. Test procedures

9.1 All specimens shall be tested in a laboratory atmosphere of 15°C to 35°C and 45 % to 75 % relative humidity.

9.2 Clamp the specimen from the upper 6 mm of its length with the longitudinal axis vertical by a heavy spring clamp or other device, so that the upper end of the tube is closed to prevent any chimney effects during the test. The lower end of the specimen shall be $300 \text{ mm} \pm 10 \text{ mm}$ above a horizontal layer of 0,05 g to 0,08 g of cotton wool of area approximately 50 mm x 50 mm and maximum thickness 6 mm (see figure 2).

9.3 Obtain the desired burner flame by adjusting the supply and air ports of the burner until a yellow-tipped blue flame of height $20 \text{ mm} \pm 1 \text{ mm}$ is produced. Increase the air supply until the yellow tip just disappears. Measure the height of the flame again and correct it to $20 \text{ mm} \pm 1 \text{ mm}$ if necessary.

9.4 Apply the flame of the burner centrally to the middle point of the bottom edge of the unlapped section (see note 5) of the specimen so that the top of the burner is $10 \text{ mm} \pm 1 \text{ mm}$ below that point of the lower end of the specimen, and maintain it at that distance for $3 \text{ s} \pm 0,5 \text{ s}$, moving the burner as necessary in response to any changes in the length or position of the specimen (see note 6). If the specimen drips molten or flaming material during the flame application, tilt the burner at an angle of up to 45° and withdraw it just sufficiently from beneath the specimen to prevent material from dropping into the barrel of the burner while maintaining the $10 \text{ mm} \pm 1 \text{ mm}$ spacing between the centre of the outlet of the burner and the remaining portion of the specimen, ignoring any strings of molten material. After the application of the flame to the specimen for $3 \text{ s} \pm 0,5 \text{ s}$, immediately withdraw the burner at a rate of approximately 300 mm/s to a distance of at least 150 mm away from the specimen and simultaneously use the timing device to commence measurement, to the nearest second, of the first afterflame time t_1 . Record t_1 .

NOTE 5 - For specimens that flare and therefore are not lapped at their lower end when suspended from the pinched upper end, the longitudinal axis of the specimen material thus becomes the direction along which the flame is applied.

NOTE 6 - For specimens which move under the influence of the burner flame, the use of a small indicator rod attached to the burner (shown in figure 3) has been found to be helpful in maintaining the 10 mm distance between the top of the burner and the major portion of the specimen.

9.5 As soon as afterflaming of the specimen ceases, even if the burner has not been withdrawn to the full 150 mm distance from the specimen, immediately place the flame of the burner again under the specimen and maintain the burner at a distance of $10 \text{ mm} \pm 1 \text{ mm}$ from the remaining portion of the specimen for $3 \text{ s} \pm 0,5 \text{ s}$ while moving the burner clear of dropping material as necessary as described in 9.4. After this application of the flame to the specimen for $3 \text{ s} \pm 0,5 \text{ s}$, immediately extinguish the burner or remove it at a rate of approximately 300 mm/s to a distance of at least 150 mm from the specimen and simultaneously, using the timing device, commence measurement to the nearest second of the second afterflame time t_2 and the afterglow time t_3 of the specimen. Note t_2 and t_3 . Note also whether the afterflame or afterglow progresses up to the 125 mm mark and whether the cotton wool layer below the specimen is ignited by material dropping from the specimen.

9.6 Repeat the procedure of 9.1 to 9.5 until at least five specimens have been tested.

10. Expression of results

10.1 For each specimen, calculate the total afterflame time using the equation:

$$t_{Fi} = t_1 + t_2$$

where

t_{Fi} is the total afterflame time for the individual specimen;
 t_1 is the first afterflame time;
 t_2 is the second afterflame time.

10.2 For each set of five specimens from both preconditioning treatments, calculate the total set afterflame time (t_{FS}) as

$$t_{FS} = \sum_{i=1}^{i=5} t_{Fi}$$

Where i is the individual specimen number and t_{Fi} is as defined above.

11. Precision

11.1 The precision data were determined from an inter-laboratory experiment conducted in 1986 involving six laboratories, four materials and two replicates. Each replicate was determined by averaging the values of five measurements. The results were analysed using ISO 5725-2 : 1994 and are summarized in table 1.

Table 1 - Precision data

Stage	Parameter	Time (s)			
		FEP ¹⁾	PI ¹⁾	PET ¹⁾	PVF ¹⁾
After first flame application	Average	0	0,5	2,5	6,0
	Repeatability	0	0,36	0,71	4,46
	Reproducibility	0	0,71	0,89	4,29
After second flame application plus glowing	Average	0	0	0,71	2,50
	Repeatability	0	0	0,71	3,93
	Reproducibility	0	0	1,25	5,18
1) Symbols for plastics materials are defined in ISO 1043-1.					

NOTE 7 - Table 1 is only intended to present a meaningful way of considering the approximate precision of this test method for a range of materials. These data should not be rigorously applied to acceptance or rejection of material, as they are specific to the interlaboratory test and may not be representative of other lots, conditions, materials or laboratories.

12. Test report

The test report shall include the following information:

- a) a reference to this International Standard;
- b) the direction of any anisotropy relative to the test specimen dimensions;
- c) the conditioning treatment;
- d) any prior treatment before testing, other than cutting, trimming and conditioning;
- e) full identification of the product tested, including the manufacturer's name, number or code;
- f) the gas used for the burner;
- g) the name and location of the test facilities;
- h) the date of the test;
- i) the individual test values, including:

- 1) specimen number (i),
- 2) specimen thickness,
- 3) first afterflame time (t_1),
- 4) second afterflame time (t_2),
- 5) total afterflame time (t_{Fi}),
- 6) total set afterflame time (t_{FS}),
- 7) afterglow time after the second flame application (t_3),
- 8) whether there was afterflame or afterglow up to the 125 mm mark,
- 9) whether the cotton wool indicator was ignited.

Annex A

(informative)

Classification system for determining the combustibility of vertical flexible specimens using a 20 mm flame source

A.1 General

This annex describes a classification system to characterize the burning behaviour of flexible materials tested in a vertical orientation using a 20 mm ignition source. The use of a category designation code is optional. Determine the category designation code by examining the test results of materials tested by this method. Each category code represents a preferred range of performance levels that simplifies description in material designations or specifications and may help certification bodies to determine compliance with applicable requirements.

A.2 Classification designations

Using the data determined from this method, select the one category code that best matches the individual specimen performance using the criteria of Table A.1. Select the designation where each individual specimen complies with all the criteria specified. Optionally record the category code in the report.

Table A.1 – Criteria and categories for classifying burning behaviour

Requirements	Category paths ¹⁾			
	≤10s	≤30s	≤30s	>30s
If: every individual afterflame time t_1 and t_2 is	≤10s	≤30s	≤30s	>30s
and: total set afterflame time (t_{FS}) is	≤50s	≤250s	≤250s	>250s
and: every individual afterglow time after the second flame application (t_3) is	≤30s	≤60s	≤60s	>60s
and: afterflame or afterglowing progresses up to the 125 mm mark	No	No	No	Yes
and: cotton indicator ignited by flaming particles or drops.	No	No	Yes	Yes or No
then: category is	VTM-0	VTM-1	VTM-2	2)
1) If only one specimen from a set of five specimens for a given conditioning treatment does not conform to the requirements for a category, another set of five specimens subjected to the same preconditioning shall be tested. All specimens from the second set shall conform to the appropriate requirements for the category. 2) Materials that cannot be categorized by this procedure. Use method A of IEC 60695-11-10:1999 to categorize material burning behaviour.				

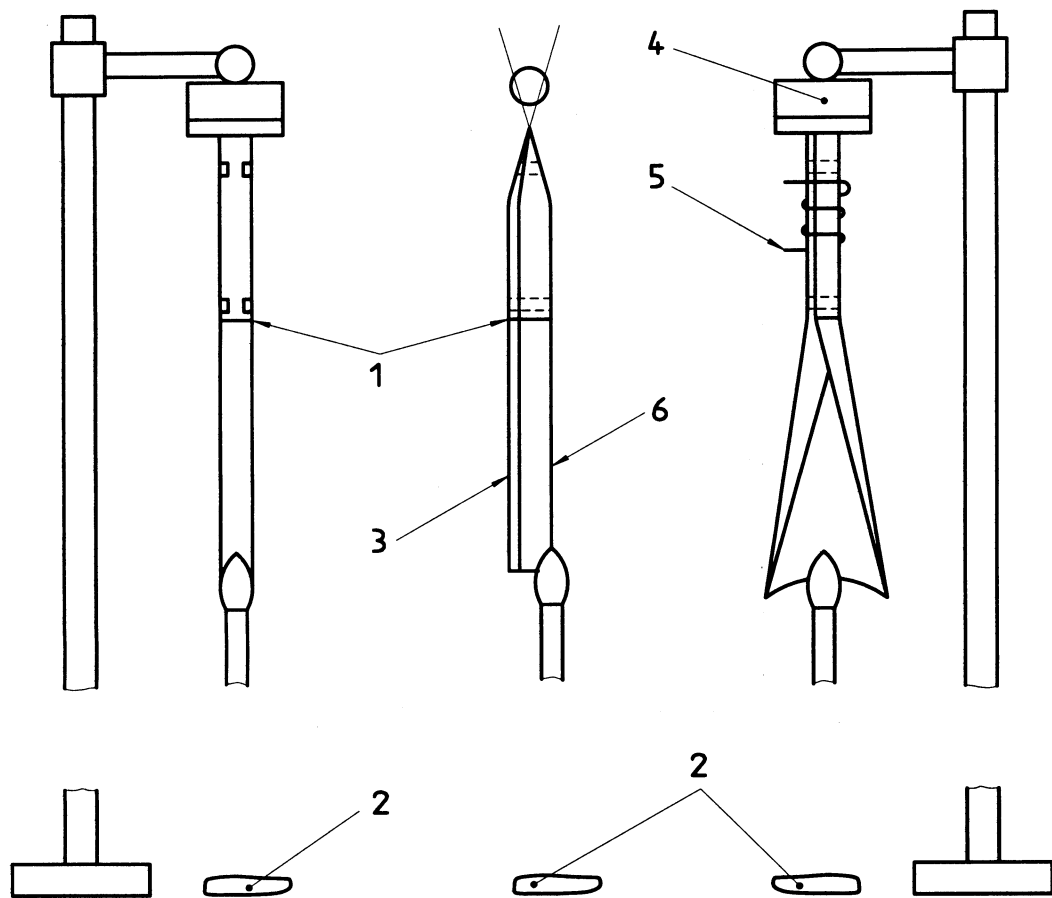

a) Front view of specimen,
lapped at lower end

b) Side view of specimen,
lapped at lower end

c) Back view of specimen, not
lapped at lower end

- 1 125 mm mark
- 2 Cotton wool
- 3 Lapped section
- 4 Spring clamp
- 5 Nichrome wire closure
- 6 Unlapped section

Figure 1 — Specimen orientation

Dimensions in millimetres

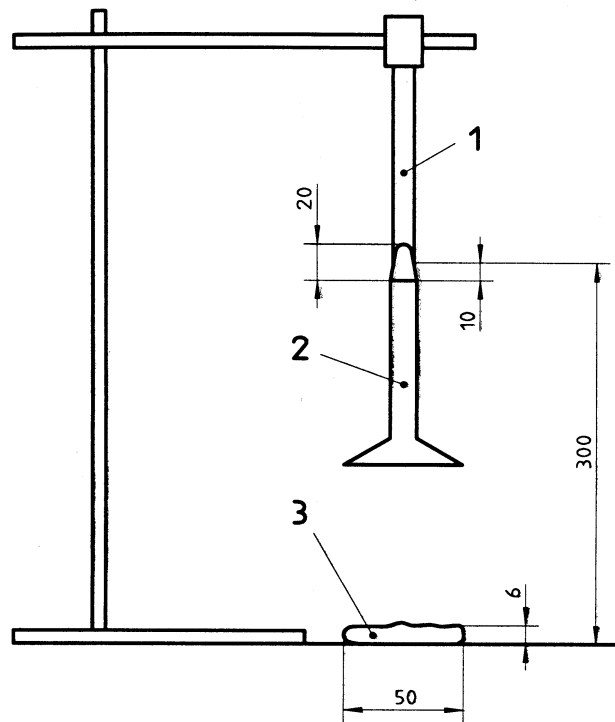

- 1 Specimen
- 2 Burner
- 3 Cotton wool

Figure 2 — Application of flame

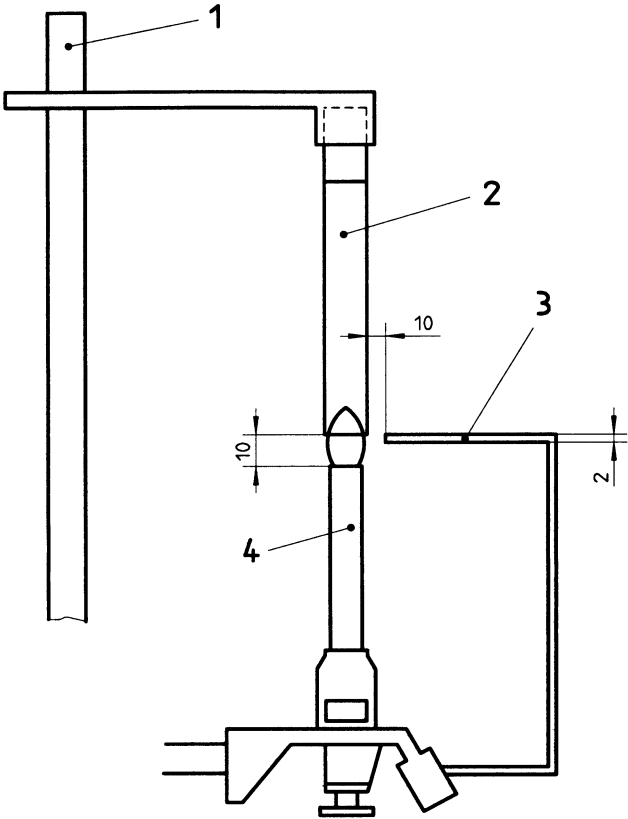

- 1 Fixed stand
- 2 Specimen
- 3 Indicator rod
- 4 Burner

Figure 3 — Burner with optional flame distance indicator

BSI — British Standards Institution

BSI is the independent national body responsible for preparing British Standards. It presents the UK view on standards in Europe and at the international level. It is incorporated by Royal Charter.

Revisions

British Standards are updated by amendment or revision. Users of British Standards should make sure that they possess the latest amendments or editions.

It is the constant aim of BSI to improve the quality of our products and services. We would be grateful if anyone finding an inaccuracy or ambiguity while using this British Standard would inform the Secretary of the technical committee responsible, the identity of which can be found on the inside front cover.
Tel: +44 (0)20 8996 9000. Fax: +44 (0)20 8996 7400.

BSI offers members an individual updating service called PLUS which ensures that subscribers automatically receive the latest editions of standards.

Buying standards

Orders for all BSI, international and foreign standards publications should be addressed to Customer Services. Tel: +44 (0)20 8996 9001.
Fax: +44 (0)20 8996 7001. Email: orders@bsi-global.com. Standards are also available from the BSI website at <http://www.bsi-global.com>.

In response to orders for international standards, it is BSI policy to supply the BSI implementation of those that have been published as British Standards, unless otherwise requested.

Information on standards

BSI provides a wide range of information on national, European and international standards through its Library and its Technical Help to Exporters Service. Various BSI electronic information services are also available which give details on all its products and services. Contact the Information Centre.
Tel: +44 (0)20 8996 7111. Fax: +44 (0)20 8996 7048. Email: info@bsi-global.com.

Subscribing members of BSI are kept up to date with standards developments and receive substantial discounts on the purchase price of standards. For details of these and other benefits contact Membership Administration.
Tel: +44 (0)20 8996 7002. Fax: +44 (0)20 8996 7001.
Email: membership@bsi-global.com.

Information regarding online access to British Standards via British Standards Online can be found at <http://www.bsi-global.com/bsonline>.

Further information about BSI is available on the BSI website at <http://www.bsi-global.com>.

Copyright

Copyright subsists in all BSI publications. BSI also holds the copyright, in the UK, of the publications of the international standardization bodies. Except as permitted under the Copyright, Designs and Patents Act 1988 no extract may be reproduced, stored in a retrieval system or transmitted in any form or by any means – electronic, photocopying, recording or otherwise – without prior written permission from BSI.

This does not preclude the free use, in the course of implementing the standard, of necessary details such as symbols, and size, type or grade designations. If these details are to be used for any other purpose than implementation then the prior written permission of BSI must be obtained.

Details and advice can be obtained from the Copyright & Licensing Manager.
Tel: +44 (0)20 8996 7070. Fax: +44 (0)20 8996 7553.
Email: copyright@bsi-global.com.