

BS EN ISO 9311-2:2011



BSI Standards Publication

Adhesives for thermoplastic piping systems

Part 2: Determination of shear strength (ISO
9311-2:2011)

bsi.

...making excellence a habit.™

National foreword

This British Standard is the UK implementation of EN ISO 9311-2:2011. It supersedes BS EN ISO 9311-2:2002 which is withdrawn.

The UK participation in its preparation was entrusted to Technical Committee PRI/52, Adhesives.

A list of organizations represented on this committee can be obtained on request to its secretary.

This publication does not purport to include all the necessary provisions of a contract. Users are responsible for its correct application.

© BSI 2011

ISBN 978 0 580 68376 3

ICS 23.040.01; 83.180

Compliance with a British Standard cannot confer immunity from legal obligations.

This British Standard was published under the authority of the Standards Policy and Strategy Committee on 31 August 2011.

Amendments issued since publication

Date	Text affected
------	---------------

English Version

**Adhesives for thermoplastic piping systems - Part 2:
Determination of shear strength (ISO 9311-2:2011)**

Adhésifs pour réseaux de tuyauteries en matières
thermoplastiques - Partie 2: Détermination de la résistance
au cisaillement (ISO 9311-2:2011)

Klebstoffe für thermoplastische Rohrleitungssysteme - Teil
2: Bestimmung der Scherfestigkeit (ISO/FDIS 9311-2:2011)

This European Standard was approved by CEN on 29 July 2011.

CEN members are bound to comply with the CEN/CENELEC Internal Regulations which stipulate the conditions for giving this European Standard the status of a national standard without any alteration. Up-to-date lists and bibliographical references concerning such national standards may be obtained on application to the CEN-CENELEC Management Centre or to any CEN member.

This European Standard exists in three official versions (English, French, German). A version in any other language made by translation under the responsibility of a CEN member into its own language and notified to the CEN-CENELEC Management Centre has the same status as the official versions.

CEN members are the national standards bodies of Austria, Belgium, Bulgaria, Croatia, Cyprus, Czech Republic, Denmark, Estonia, Finland, France, Germany, Greece, Hungary, Iceland, Ireland, Italy, Latvia, Lithuania, Luxembourg, Malta, Netherlands, Norway, Poland, Portugal, Romania, Slovakia, Slovenia, Spain, Sweden, Switzerland and United Kingdom.



EUROPEAN COMMITTEE FOR STANDARDIZATION
COMITÉ EUROPÉEN DE NORMALISATION
EUROPÄISCHES KOMITEE FÜR NORMUNG

Management Centre: Avenue Marnix 17, B-1000 Brussels

Foreword

This document (EN ISO 9311-2:2011) has been prepared by Technical Committee CEN/TC 193 "Adhesives", the secretariat of which is held by AENOR, in collaboration with Technical Committee ISO/TC 138 "Plastics pipes, fittings and valves for the transport of fluids".

This European Standard shall be given the status of a national standard, either by publication of an identical text or by endorsement, at the latest by February 2012, and conflicting national standards shall be withdrawn at the latest by February 2012.

Attention is drawn to the possibility that some of the elements of this document may be the subject of patent rights. CEN [and/or CENELEC] shall not be held responsible for identifying any or all such patent rights.

This document supersedes EN ISO 9311-2:2002.

According to the CEN/CENELEC Internal Regulations, the national standards organizations of the following countries are bound to implement this European Standard: Austria, Belgium, Bulgaria, Croatia, Cyprus, Czech Republic, Denmark, Estonia, Finland, France, Germany, Greece, Hungary, Iceland, Ireland, Italy, Latvia, Lithuania, Luxembourg, Malta, Netherlands, Norway, Poland, Portugal, Romania, Slovakia, Slovenia, Spain, Sweden, Switzerland and the United Kingdom.

Foreword

ISO (the International Organization for Standardization) is a worldwide federation of national standards bodies (ISO member bodies). The work of preparing International Standards is normally carried out through ISO technical committees. Each member body interested in a subject for which a technical committee has been established has the right to be represented on that committee. International organizations, governmental and non-governmental, in liaison with ISO, also take part in the work. ISO collaborates closely with the International Electrotechnical Commission (IEC) on all matters of electrotechnical standardization.

International Standards are drafted in accordance with the rules given in the ISO/IEC Directives, Part 2.

The main task of technical committees is to prepare International Standards. Draft International Standards adopted by the technical committees are circulated to the member bodies for voting. Publication as an International Standard requires approval by at least 75 % of the member bodies casting a vote.

Attention is drawn to the possibility that some of the elements of this document may be the subject of patent rights. ISO shall not be held responsible for identifying any or all such patent rights.

ISO 9311-2 was prepared by the European Committee for Standardization (CEN) Technical Committee CEN/TC 193, *Adhesives*, in collaboration with Technical Committee ISO/TC 138, *Plastics pipes, fittings and valves for the transport of fluids*, Subcommittee SC 5, *General properties of pipes, fittings and valves of plastic materials and their accessories — Test methods and basic specifications*, in accordance with the Agreement on technical cooperation between ISO and CEN (Vienna Agreement).

This second edition cancels and replaces the first edition (ISO 9311-2:2002), which has been technically revised.

ISO 9311 consists of the following parts, under the general title *Adhesives for thermoplastic piping systems*:

- *Part 1: Determination of film properties*
- *Part 2: Determination of shear strength*
- *Part 3: Test method for the determination of resistance to internal pressure*

Introduction

The aim of this part of ISO 9311 is to describe a method to characterize adhesives for thermoplastic piping systems by measuring the shear strength of a bonded joint using a test specimen prepared as described. The results obtained with this method cannot be extrapolated into the resistance of a different specimen – perhaps the real life article – to destructive shear forces.

Adhesives for thermoplastic piping systems —

Part 2: Determination of shear strength

SAFETY PRECAUTIONS — Persons using this document should be familiar with the normal laboratory practice, if applicable. This document does not purport to address all of the safety problems, if any, associated with its use. It is the responsibility of the user to establish appropriate safety and health practices and to ensure compliance with any regulatory conditions.

CAUTION — It is understood that some of the material permitted in this standard may have negative environmental impact. As technological advantages lead to acceptable alternatives for these materials, they will be eliminated from this standard to the extent possible.

At the end of the test, the user of the standard shall take care to carry out an appropriate disposal of the wastes, according to local regulation.

1 Scope

This part of ISO 9311 specifies a method for the determination of the shear strength of joints made with adhesives for thermoplastic piping systems.

2 Normative references

The following referenced documents are indispensable for the application of this document. For dated references, only the edition cited applies. For undated references, the latest edition of the referenced document (including any amendments) applies.

ISO 15605, *Adhesives — Sampling*

EN 923, *Adhesives — Terms and definitions*

EN 1067, *Adhesives — Examination and preparation of samples for testing*

3 Terms and definitions

For the purposes of this document, the terms and definitions given in EN 923 and the following apply.

3.1

diametrical clearance

difference between the mean outside diameter of the pipe and the mean inside diameter of the socket

4 Principle

The aim is to describe a method to obtain test joints of given dimensions from pipes and fittings, and the measurement of the shear strength of a joint made with the pipes and fittings, but bonded with an adhesive under examination, under specified test conditions.

NOTE It is assumed that the following parameters are set by the reference standards such as EN 14680 and EN 14814, making reference to the test method described in this part of ISO 9311, namely:

- a) the pipe and fitting to be used,
- b) the diametrical clearance in the bonded assembly, and
- c) the setting time.

5 Apparatus

5.1 A tensile or press testing machine, able to move the jaws at a uniform and steady rate of $(5 \pm 0,5)$ mm/min.

5.2 A jig, to connect the test assembly to the machine (suitable arrangements are illustrated in Figures 1, 2 and 3).

Dimensions in millimetres

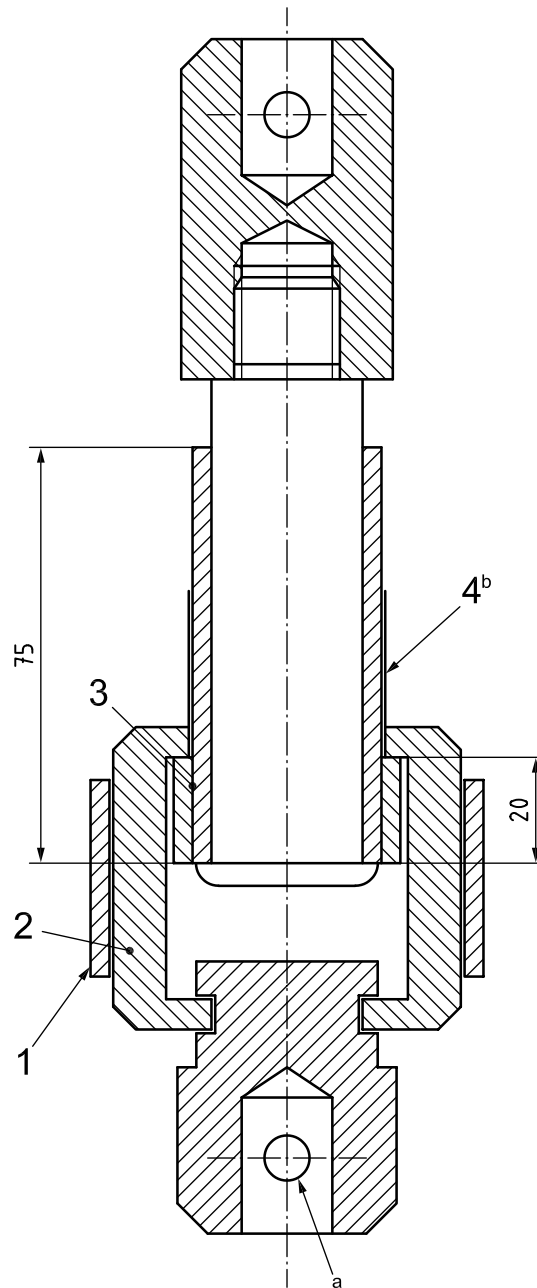

Key

- 1 retaining ring
- 2 split collar
- 3 bonded assembly
- 4 collar
- a Connection to tensile machine.
- b Internal diameter of collar shall not be less than the outside diameter of the pipe.

Figure 1 — Example of connecting jig

Dimensions in millimetres

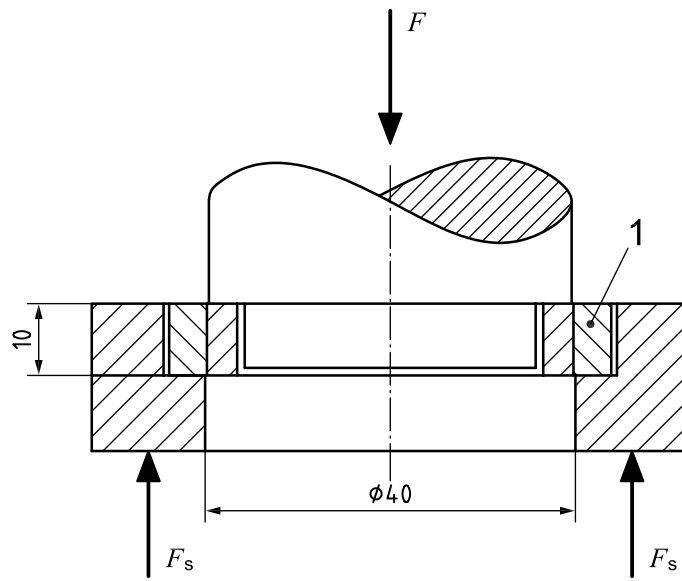

Key

- 1 bonded assembly
- F pressing device
- F_s shear strength

Figure 2 — Example of connecting jig for a reduced bonded area

Dimensions in millimetres

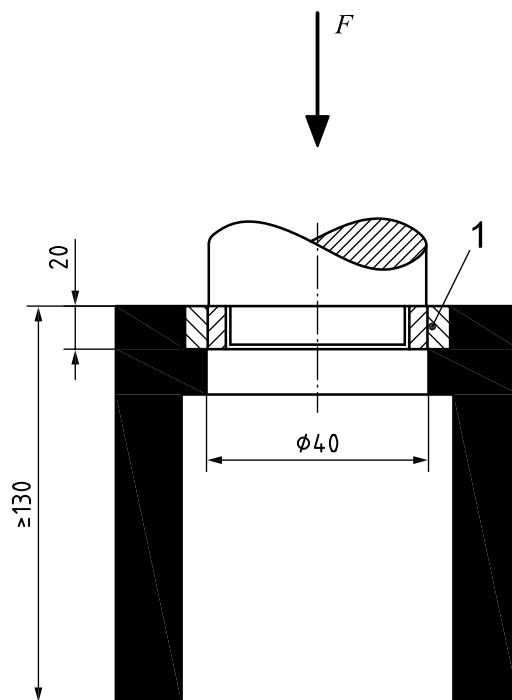

Key

- 1 bonded assembly
- F pressing device

Figure 3 — Example of connecting jig for pressing device

6 Sampling

Take a representative sample of the adhesive to be tested in accordance with ISO 15605 and examine and prepare it for testing in accordance with EN 1067.

7 Procedure

7.1 For each test, prepare five test assemblies each one made of a pipe length 75 mm, external diameter 40 mm, and a fitting with a joint contact depth of 20 mm minimum. The assembly shall be of a suitable total wall thickness to withstand the force applied during the test. The diametrical clearance shall be obtained by means of a lathe on the internal fitting surface and never on the pipe external diameter.

7.2 Prepare the pipe and fitting contact surfaces following the adhesive manufacturer recommendations. Remove any swarf and other debris from the joining surfaces of the fitting and pipe.

7.3 Condition the test pieces at $(23 \pm 2) ^\circ\text{C}$ and $(50 \pm 5) \%$ relative humidity for at least 6 h.

7.4 Apply the adhesive as recommended by the adhesive manufacturer.

7.5 Maintain the test assemblies under the curing conditions $(23 \pm 2) ^\circ\text{C}$ and $(50 \pm 5) \%$ relative humidity unless otherwise specified in the relevant product standard. Test pieces have to be maintained in vertical position during the curing time.

7.6 Place the test assembly in the appropriate jig at the required test temperature and apply a force by separation or compression at a rate of $(5 \pm 0,5) \text{ mm/min}$.

7.7 Record the maximum force required that causes failure of the bonded assembly.

7.8 If the force required to cause failure exceeds the maximum load of the testing equipment, reduce the bonded area by cutting, just before the specified setting time ends, a ring of width 10 mm from the bonded area of the test assembly (a suitable jig for the ring is illustrated in Figure 2).

8 Expression of results

Calculate the shear strength, F_s , in Megapascals (MPa) of each test assembly using Equation (1):

$$F_s = \frac{F}{\pi dl} \quad (1)$$

where

F is the force required to cause failure, in Newtons;

d is the internal diameter of the fitting, in millimetres;

l is the length of the joint, in millimetres.

The shear strength is the arithmetic mean of the results obtained for the five test assemblies.

No result shall be discarded and no correction shall be applied to apparently doubtful results without a justification based on experimental, technical or other evident grounds, which should be clearly stated.

9 Test report

The test report shall include, at least, the following information:

- a) a reference to this part of ISO 9311, i.e. ISO 9311-2:2011;
- b) type and identification (batch number, date of manufacture or other code) of the adhesive tested;
- c) the method used to prepare the test pieces and their joint contact surfaces;
- d) the shear strength of the individual tests, the arithmetic means, together with the information about discarded results;
- e) diametrical clearance between pipe and fitting;
- f) the curing conditions;
- g) the required setting time;
- h) the test temperature;
- i) the complete identification and reference of pipes and fittings used and their dimensions;
- j) any modification to the procedure described in this part of ISO 9311 and any circumstances which may have affected the results;
- k) the date of test.

Bibliography

- [1] EN 14680:2006, *Adhesives for non-pressure thermoplastic piping systems — Specifications*
- [2] EN 14814:2007, *Adhesives for thermoplastic piping systems for fluids under pressure — Specifications*

British Standards Institution (BSI)

BSI is the national body responsible for preparing British Standards and other standards-related publications, information and services.

BSI is incorporated by Royal Charter. British Standards and other standardization products are published by BSI Standards Limited.

About us

We bring together business, industry, government, consumers, innovators and others to shape their combined experience and expertise into standards-based solutions.

The knowledge embodied in our standards has been carefully assembled in a dependable format and refined through our open consultation process. Organizations of all sizes and across all sectors choose standards to help them achieve their goals.

Information on standards

We can provide you with the knowledge that your organization needs to succeed. Find out more about British Standards by visiting our website at bsigroup.com/standards or contacting our Customer Services team or Knowledge Centre.

Buying standards

You can buy and download PDF versions of BSI publications, including British and adopted European and international standards, through our website at bsigroup.com/shop, where hard copies can also be purchased.

If you need international and foreign standards from other Standards Development Organizations, hard copies can be ordered from our Customer Services team.

Subscriptions

Our range of subscription services are designed to make using standards easier for you. For further information on our subscription products go to bsigroup.com/subscriptions.

With **British Standards Online (BSOL)** you'll have instant access to over 55,000 British and adopted European and international standards from your desktop. It's available 24/7 and is refreshed daily so you'll always be up to date.

You can keep in touch with standards developments and receive substantial discounts on the purchase price of standards, both in single copy and subscription format, by becoming a **BSI Subscribing Member**.

PLUS is an updating service exclusive to BSI Subscribing Members. You will automatically receive the latest hard copy of your standards when they're revised or replaced.

To find out more about becoming a BSI Subscribing Member and the benefits of membership, please visit bsigroup.com/shop.

With a **Multi-User Network Licence (MUNL)** you are able to host standards publications on your intranet. Licences can cover as few or as many users as you wish. With updates supplied as soon as they're available, you can be sure your documentation is current. For further information, email bsmusales@bsigroup.com.

BSI Group Headquarters

389 Chiswick High Road London W4 4AL UK

Revisions

Our British Standards and other publications are updated by amendment or revision.

We continually improve the quality of our products and services to benefit your business. If you find an inaccuracy or ambiguity within a British Standard or other BSI publication please inform the Knowledge Centre.

Copyright

All the data, software and documentation set out in all British Standards and other BSI publications are the property of and copyrighted by BSI, or some person or entity that owns copyright in the information used (such as the international standardization bodies) and has formally licensed such information to BSI for commercial publication and use. Except as permitted under the Copyright, Designs and Patents Act 1988 no extract may be reproduced, stored in a retrieval system or transmitted in any form or by any means – electronic, photocopying, recording or otherwise – without prior written permission from BSI. Details and advice can be obtained from the Copyright & Licensing Department.

Useful Contacts:

Customer Services

Tel: +44 845 086 9001

Email (orders): orders@bsigroup.com

Email (enquiries): cservices@bsigroup.com

Subscriptions

Tel: +44 845 086 9001

Email: subscriptions@bsigroup.com

Knowledge Centre

Tel: +44 20 8996 7004

Email: knowledgecentre@bsigroup.com

Copyright & Licensing

Tel: +44 20 8996 7070

Email: copyright@bsigroup.com



...making excellence a habit.™