

Ergonomics of human- system interaction

Part 410: Design criteria for physical input devices

ICS 13.180; 35.180

National foreword

This British Standard is the UK implementation of EN ISO 9241-410:2008+A1:2012. It supersedes BS EN ISO 9241-410:2008, which is withdrawn. Together with BS EN ISO 9241-400:2007, PD CEN ISO/TS 9241-411:2014 and BS EN ISO 9241-420:2011, it supersedes BS EN ISO 9241-4:1998 and BS EN ISO 9241-9:2000, which are withdrawn.

The UK participation in its preparation was entrusted to Technical Committee PH/9, Applied ergonomics.

A list of organizations represented on this committee can be obtained on request to its secretary.

The publication does not purport to include all the necessary provisions of a contract. Users are responsible for its correct application.

Compliance with a British Standard cannot confer immunity from legal obligations.

This British Standard was published under the authority of the Standards Policy and Strategy Committee on 30 April 2009

© The British Standards Institution 2014.
Published by BSI Standards Limited 2014

Amendments/corrigenda issued since publication

| Date | Comments |
|-------------------|---|
| 30 November 2012 | Implementation of ISO amendment 1:2012 with CEN endorsement A1:2012: Clause 2 has been updated, Clause 10 has been inserted. The identifier has also been aligned with original CEN publication date. |
| 30 September 2014 | Correction to supersession information in national foreword |
| | |
| | |

ICS 13.180; 35.180

English Version

**Ergonomics of human-system interaction - Part 410: Design
criteria for physical input devices (ISO 9241-410:2008)**

Ergonomie de l'interaction homme-système - Partie 410:
Critères de conception des dispositifs d'entrée physiques
(ISO 9241-410:2008)

Ergonomie der Mensch-System-Interaktion - Teil 410:
Gestaltungskriterien für physikalische Eingabegeräte (ISO
9241-410:2008)

This European Standard was approved by CEN on 11 February 2008.

CEN members are bound to comply with the CEN/CENELEC Internal Regulations which stipulate the conditions for giving this European Standard the status of a national standard without any alteration. Up-to-date lists and bibliographical references concerning such national standards may be obtained on application to the CEN Management Centre or to any CEN member.

This European Standard exists in three official versions (English, French, German). A version in any other language made by translation under the responsibility of a CEN member into its own language and notified to the CEN Management Centre has the same status as the official versions.

CEN members are the national standards bodies of Austria, Belgium, Bulgaria, Cyprus, Czech Republic, Denmark, Estonia, Finland, France, Germany, Greece, Hungary, Iceland, Ireland, Italy, Latvia, Lithuania, Luxembourg, Malta, Netherlands, Norway, Poland, Portugal, Romania, Slovakia, Slovenia, Spain, Sweden, Switzerland and United Kingdom.



EUROPEAN COMMITTEE FOR STANDARDIZATION
COMITÉ EUROPÉEN DE NORMALISATION
EUROPÄISCHES KOMITEE FÜR NORMUNG

Management Centre: rue de Stassart, 36 B-1050 Brussels

Foreword to amendment A1

This document (EN ISO 9241-410:2008/A1:2012) has been prepared by Technical Committee ISO/TC 159 "Ergonomics" in collaboration with Technical Committee CEN/TC 122 "Ergonomics" the secretariat of which is held by DIN.

This European Standard shall be given the status of a national standard, either by publication of an identical text or by endorsement, at the latest by January 2013, and conflicting national standards shall be withdrawn at the latest by January 2013.

Attention is drawn to the possibility that some of the elements of this document may be the subject of patent rights. CEN [and/or CENELEC] shall not be held responsible for identifying any or all such patent rights.

According to the CEN/CENELEC Internal Regulations, the national standards organizations of the following countries are bound to implement this European Standard: Austria, Belgium, Bulgaria, Croatia, Cyprus, Czech Republic, Denmark, Estonia, Finland, Former Yugoslav Republic of Macedonia, France, Germany, Greece, Hungary, Iceland, Ireland, Italy, Latvia, Lithuania, Luxembourg, Malta, Netherlands, Norway, Poland, Portugal, Romania, Slovakia, Slovenia, Spain, Sweden, Switzerland, the United Kingdom and Turkey.

Endorsement notice

The text of ISO 9241-410:2008/AMD 1:2012 has been approved by CEN as a EN ISO 9241-410:2008/A1:2012 without any modification.

Introduction

Input devices are a means for users to enter data into interactive systems. Generally speaking, an input device is a sensor that can detect changes in user behaviour (gestures, moving fingers, etc.) and transform it into signals to be interpreted by the interactive system. An *input device* is regarded as the combination of hardware with the software designed to use it (e.g. a driver).

This part of ISO 9241 defines design criteria for products on the basis of relevant properties of physical input devices as laid down in ISO 9241-400:2007. It is intended to cover assessment methods for laboratory use (in order to accelerate future development of test and evaluation methods) and user organizations in future parts of ISO 9241.

Most of the principles presented in this part of ISO 9241 have previously been defined or outlined in International Standards for keyboards and other input devices (ISO 9241-4 and ISO 9241-9). Where necessary, definitions of terms have been reformulated so that they are applicable for all input devices.

ISO 9241 was originally developed as a seventeen-part International Standard on the ergonomics requirements for office work with visual display terminals. As part of the standards review process, a major restructuring of ISO 9241 was agreed to broaden its scope, to incorporate other relevant standards and to make it more usable. The general title of the revised ISO 9241, "Ergonomics of human-system interaction", reflects these changes and aligns the standard with the overall title and scope of Technical Committee ISO/TC 159, *Ergonomics*, Subcommittee SC 4, *Ergonomics of human-system interaction*. The revised multipart standard is structured as a series of standards numbered in the "hundreds": the 100 series deals with software interfaces, the 200 series with human centred design, the 300 series with visual displays, the 400 series with physical input devices and so on.

See Annex A for an overview of the entire ISO 9241 series.

Ergonomics of human-system interaction –

Part 410:

Design criteria for physical input devices

1 Scope

This part of ISO 9241 specifies criteria based on ergonomics factors for the design of physical input devices for interactive systems including keyboards, mice, pucks, joysticks, trackballs, trackpads, tablets and overlays, touch-sensitive screens, styli and light pens, and voice- and gesture-controlled devices. It gives guidance on the design of these devices, taking into consideration the capabilities and limitations of users, and specifies generic design criteria for physical input devices, as well as specific criteria for each type of device. Requirements for the design of products are given either as a result of context-free considerations, or else can be determined based on the specified design criteria for the intended use; such specified criteria generally having been subdivided into task-oriented categories, wherever applicable.

EXAMPLE The resolution of a pointing device is given in relation to four levels of index of difficulty for the Fitts test. The required category for the resolution can be determined on the basis of the task characteristics, user population and context of use for the intended application.

This part of ISO 9241 does not specify the categories that are appropriate for devices as, according to the concept of usability, a product has no *inherent* usability. Selecting the category to which a certain property of a device belongs is subject to the design of a product.

This part of ISO 9241 is expected to be used by the manufacturers of physical input devices, including product designers and test organizations, in determining the design characteristics of a device for its intended context of use (user population, task, software or environment, etc.). The data generated by the users of this part of ISO 9241 for the description of the properties of their products can be applied in the selection of a device adequate for the actual context of use on the basis of the task primitives relevant for the task of the specific user population, and for achieving the required level of efficiency and effectiveness for a given system.

2 Normative references

The following referenced documents are indispensable for the application of this document. For dated references, only the edition cited applies. For undated references, the latest edition of the referenced document (including any amendments) applies.

ISO 7000, *Graphical symbols for use on equipment – Index and synopsis*

ISO 9241-400:2007, *Ergonomics of human-system interaction – Part 400: Principles and requirements for physical input devices*

ISO/TS 9241-411, *Ergonomics of human-system interaction — Part 411: Evaluation methods for the design of physical input devices*

ISO/IEC 9995 (all parts), *Information technology – Keyboard layouts for text and office systems*

IEC 60417-DB, *Graphical symbols for use on equipment*²⁾

2) Permanently updated database.

3 Terms and definitions

For the purposes of this document, the terms and definitions given in ISO 9241-400 and the following apply:

3.1

bounce-free switch

switch that generates a single and definite signal after actuation

3.2

category

part of a system into which properties of entities can be arranged

3.3

class

category of a property of a product with rank order

NOTE 1 Class 1 is the *most*, and class n the *least*, favourable category of a specific property of a product, where n is the number of classes.

NOTE 2 An example of a property is *durability of the legends* of a key. If a key belongs to the highest class, it will fulfil all requirements for the lower categories.

3.4

compact keyboard

keyboard that features most properties of a full-size keyboard, with the editing section integrated into the alphanumeric section

NOTE A compact keyboard can have a numeric section.

3.5

force feedback

application of physical force in response to user input

EXAMPLE In games, or in car and plane simulators.

3.6

full-size keyboard

keyboard that comprises all sections and zones as described in ISO/IEC 9995-1

3.7

group

category of a property of a product without rank order

NOTE Some properties such as the size of a key do not constitute a virtue without further considerations. For such properties, the categorization may help to differentiate objects without being able to determine a rank in consideration of the specific property.

EXAMPLE A particular size of key on a keyboard that is suited for continuous touch-typing, a smaller key size for hand-held devices or a larger size for use with gloves.

3.8

haptic, adj

of or relating to, or proceeding from, the sense of touch

3.9

haptic display

display presenting information accessible through the sense of touch, mainly by, but not limited to, use of hands and fingers

3.10

haptic interface

user interface based on touch, using the movements of the user as input and the sense of touch as output for tactile and kinaesthetic feedback

EXAMPLE Force feedback joysticks, Braille screen readers.

3.11

housing

protective cover designed to contain or support a mechanical component

NOTE An input device is either integrated into its own housing or into another unit that comprises other functional units (e.g. control desk, control panel, telephone).

3.12

index of difficulty

I_D

measure of the user precision required in a task

NOTE The index of difficulty, I_D , is measured in bits, and is calculated for selection, pointing, or dragging tasks by

$$I_D = \log_2 \frac{d + w}{w}$$

and for tracing tasks by

$$I_D = \frac{d}{w}$$

where

d is the distance of movement to the target;

w is the target width of the displayed target along the approach axis for selection, pointing or dragging tasks, and perpendicular for tracing tasks.

3.13

key arrangement

spatial organization of keys of a keyboard following certain design rules or conventions

EXAMPLE Typewriter, calculator or telephone layout of keys for generating codes for numerals (numeric keys for digits 0 to 9) on office machines.

3.14

keypad

functional unit that comprises at least a group of keys dedicated and arranged for a given functionality and possibly additional keys supporting related functionality

EXAMPLE Numeric keys, "Enter" key of keypad.

3.15

multi-tap

alphanumeric input requiring several presses per character

3.16

section

(keyboard) functional groups within computer keyboards for which different rules for layouts can apply

NOTE Some sections of existing keyboards are arranged according to more-than-century-old conventions.

3.17

task precision

measure of the accuracy required for a pointing, selecting or dragging task primitive, quantified by the index of difficulty

3.18

touchpad

touch-sensitive pad that senses the position of a finger on its surface

3.19

work surface

surface on which equipment and task materials are used

[ISO 9241-5:1998, definition 3.25]

3.20

zone

(keyboard) smaller unit within a section of a keyboard representing different functionality

EXAMPLE The layout of the alphanumeric keys for entering graphic characters (alphanumeric zone) grouped with function and modifier keys such as “Ctrl”, “Alt”, “Tab” or “Backspace”.

4 Procedure for applying this part of ISO 9241

Generally speaking, the entirety of requirements for the overall design of a product is a result of considerations from a variety of origins, such as engineering, safety, environmental protection, economic efficiency, marketing or the concept of usability (see ISO 9241-400).

This part of ISO 9241 presents requirements related to product properties that are in turn related to usability of physical input devices. Its application requires following steps a) to d), below.

a) Identify properties of the device that are relevant for usability.

First, identify those properties relevant to usability, i.e. relevant for the effectiveness and efficiency of use and for the satisfaction of user needs. Some of the properties are known (e.g. key legends for keyboard) and requirements for them exist for certain areas of use (e.g. minimum size of key legends for full-size keyboards).

b) Apply generic design requirements

Identify other properties by applying the generic design principles on a specific device (e.g. controllability on keyboards or mice). The requirements for these properties can be different for different contexts of use. For these properties, the requirements are subdivided into categories — classes or groups. Specify the category to which a device belongs. The device will need to conform to the requirements that apply to that category.

c) Apply device specific design requirements

For each relevant property, apply the requirements for a specific device (see Annexes B to J). See Figure 1 for a summary of these requirements.

d) Evaluate the performance criterion

Ensure that the device fulfils the requirements derived from the provisions of this part of ISO 9241, while considering the product’s designated purpose.

NOTE A *product* is considered as being any combination of hardware and software utilized for a given task.

| Relevant Properties | | | |
|-----------------------|-----------------------|------------------------------|---------------------|
| | | Property | Class/ Group/ Value |
| 1 | Appropriateness | Effectiveness | ■ ■ ■ □ |
| | | Efficiency | ■ ■ ■ □ |
| | | Dimensioning | ■ ■ ■ ■ |
| | | Software dependency | ✓ |
| | | Additional device | ○ ← 2 |
| | Operability | Obviousness | ■ ■ ■ ■ |
| | | Predictability | ■ ■ ■ ■ ← 3 |
| | | Correct order | ■ ■ ■ □ |
| | | Consistency | ■ ■ ■ □ |
| | | Compatibility | ■ ■ ■ □ |
| | Controllability | Responsiveness | ■ ■ ■ ■ |
| | | Non-interference | ■ ■ ■ ■ |
| | | Reliability of device access | ■ ■ ■ ■ |
| | | Adequacy of device access | ■ ■ ■ ■ |
| | | Control access | ■ ■ ■ ■ |
| | Biomech. Load | Postures | ■ ■ □ □ |
| | | Effort | ■ ■ ■ □ |
| | Functional Properties | Keys | Size |
| Roll-over | | | ■ ■ ■ □ |
| Durability of legends | | | ■ ■ □ □ |
| Sections and zones | | Alphanumeric | ✓ ← 5 |
| | | Numeric | ○ |
| | | Editing | ✓ |
| | | Function | ✓ |
| | | Multimedia | -- ← 6 |

Key

- 1 requirement derived from a generic design principle
- 2 not relevant
- 3 property with requirements in four groups
- 4 property with requirements in four classes
- 5 property with requirements
- 6 property without requirements in this document

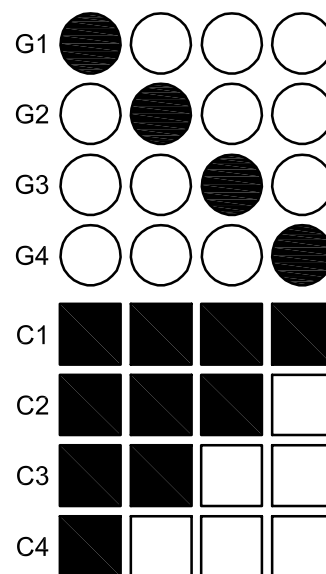

Figure 1 – Sample for a summarizing table

5 Performance criterion

The input device shall be usable for its designated purpose. It is considered *usable* if its user can achieve a satisfactory level of performance on a given task and maintain an acceptable level of effort and satisfaction. This objective is met when the design requirements and recommendations (see Annexes B to J) applicable to the device are satisfied.

If completing the task requires the utilization of more than one physical device, all elements specified shall be treated as a unit for the purposes of determining usability.

6 Properties of physical input devices relevant for usability

Properties of physical input devices with relevance for usability can be broken down into groups of properties. Requirements can either be derived from a generic design principle to which various properties can contribute or the relevant property can be identified without applying a principle. Properties with requirements in groups serve to categorize products without the ability to assign them to classes, whereas other properties can be categorized into classes with rank order:

- functional properties;
- mechanical properties;
- electrical properties;
- maintainability-related properties;
- health- and safety-related properties;
- interdependency with software;
- interdependency with use environment.

For such properties, requirements or recommendations exist based on technical knowledge, scientific evidence or conventions. The relevance of additional (or sometimes the same) properties can be identified or established in consideration of the generic design principles presented in ISO 9241-400. This part of ISO 9241 specifies design requirements for each device derived from those principles. Other properties corresponding to a certain principle equally or even better suited may be used instead.

EXAMPLE 1 The form of the housing of a mouse is relevant if the user has no equivalent or better means to sense the orientation of the device (principle: controllability, reliability of device access).

EXAMPLE 2 The orientation of a button for minimizing finger extension is relevant if the button is located on a mouse where the button will be actuated without losing overall control of the device (principle: controllability, control access). For other buttons, the orientation might not be relevant.

7 Generic design requirements for physical input devices

7.1 General

The intended use of a physical input device shall be specified unless it is obvious or the product is designed for general-purpose use. The specification shall include technical conditions for the context of use to be realized for satisfactory use of the device (e.g. operating system, driver, support surface).

Each physical entity possesses a number of properties, of which only some are relevant for its usability. Since a device cannot have intrinsic usability, for each relevant property subject to a design requirement, wherever

possible four categories are given. If sufficient knowledge exists to recommend a certain category, this is indicated.

NOTE The category required for a given task, intended user population and/or context of use (e.g. stationary, portable, hand-held and in different environments) will be able to be determined using procedures given in a future part of ISO 9241.

7.2 Generic design requirements

7.2.1 General

This clause derives generic design requirements from the ergonomic principles that apply to all input devices as defined in ISO 9241-400:2007, 4.2. These are

- appropriateness,
- operability,
- controllability, and
- biomechanical load.

7.2.2 Appropriateness

The design of a device shall be appropriate for the intended tasks being performed and the intended use environment, including additional devices if required by the task. An appropriate input device enables the user to achieve the required effectiveness for the task and is efficient and satisfactory for the intended user population.

The dimensioning of an input device and its parts shall be compatible with the relevant anthropometric dimensions of the part of the body for the intended user population so that relevant design objectives can be met (intended level of effectiveness, intended level of efficiency).

If the design objectives cannot be met without the use of additional tools (e.g. stylus for input via small size keys) or if, in order to achieve the intended level of appropriateness, the design requires enhancement by software or the additional use of a device other than is delivered with the device under consideration, then this shall be specified.

7.2.3 Operability

7.2.3.1 General

An input device shall be operable, i.e. its intended use is obvious, predictable and consistent and the user receives adequate feedback.

7.2.3.2 Obviousness

The obviousness of the intended use can be categorized into four classes:

- C1 known or visible without additional instructions and information;
- C2 detectable by the user by trial and error;
- C3 learnable by simple instructions;
- C4 learnable by special training.

7.2.3.3 Predictability

The predictability of the input is achieved if the movement or other activation of the input device consistently produces a directly corresponding movement of the display or desired action by the system, e.g. movement of an input device in one of the cardinal directions (up, down, left, right), or if a voice command to the same effect consistently produces movement of the pointer in the same direction on the screen.

7.2.3.4 Consistency of operation

Consistency of operation is provided if the device operates and responds in the same manner in the specified context of use.

Operating in the same manner means that the same level of effectiveness is maintained under the intended context of use.

Responding in the same manner means that the user receives the same feedback through the same channels (e.g. tactile, visual or auditory).

7.2.3.5 User compatibility

7.2.3.5.1 General requirement

Physical input devices shall be user-compatible, i.e. their design accommodates the intended user anthropometric characteristics and biomechanical capabilities.

7.2.3.5.2 Throughput

The anthropometric characteristics of the intended user population can be accommodated in four classes:

- C1 fully compatible, enables maximum throughput and accuracy;
- C2 restricted (level 1), maximum achievable level for effectiveness 90 %, efficiency 90 %;
- C3 restricted (level 2), maximum achievable level for effectiveness 80 %, efficiency 80 %;
- C4 use requires additional aids.

7.2.3.5.3 Force and posture

The compatibility with biomechanical capabilities of the intended user population can be categorized by the degree to which a fraction of the maximum capability (e.g. angle of joint, contracting force of a muscle) is needed for the operation of the device.

NOTE Current scientific knowledge does not allow a setting up of such categories valid for all input devices. Therefore, this part of ISO 9241 does not include categories for the angle of joints and the contracting force of muscle.

7.2.3.6 Feedback

An input device shall provide effective feedback, i.e. the user is given immediately perceptible and understandable indication that the device is responding to user actuation (see ISO 9241-400). The feedback generated by the operation of an input device is only partly transmitted by that device to the users, e.g. by tactile feedback while actuating a button. Some input devices such as gesture-sensitive cameras do not provide any feedback except that generated by the system. Thus, the adequacy of feedback is highly software-dependent.

An input device shall either give adequate feedback by its own functionality or generate a signal enabling the system to provide feedback. The feedback is adequate if the user can detect the following without taking further action:

- current state of the device;
- outcome of the latest action (e.g. input accepted, required action initiated);
- any action required as consequence of the latest action.

Users with special needs or use conditions may require certain types of feedback. For example, feedback through the same channel (tactile feedback by the button that is being actuated) could be needed if visual or acoustic feedback are likely to fail. In other cases, feedback through a diverse channel may be beneficial if the channel that is being used for an action does not accept the response, e.g. the acceptance of a text that is being dictated cannot be confirmed continuously by sound, but by visual or tactile feedback.

7.2.4 Controllability

7.2.4.1 General

The operation of an input device shall be controllable. This means that

- the device shall be responsive, and its use shall not interfere with its functionality,
- the design of the device shall give the user adequate and reliable access, and
- the design shall prevent unintended loss of control during intended use, e.g. slipping by hand-operated devices.

NOTE See ISO 9241-110 for details concerning controllability in dialogue design in general.

7.2.4.2 Responsiveness

Responsiveness of an input device occurs if the feedback following its actuation is consistent and sufficient.

EXAMPLE Activating a graphic key on a keyboard is always accompanied by a generated character on the screen and by a tactile feedback that is the same for all keys on that keyboard.

7.2.4.3 Non-interference

An input device shall not interfere with its own use. This means that all functional elements belonging to that device can be accessed and operated without degrading the usability of the device. Functional elements needed to transport data from the device to the system and vice-versa (cables, infrared beams) shall not influence throughput and accuracy.

EXAMPLE 1 The user's hand or arm does not block an infrared beam.

EXAMPLE 2 A computer mouse is not pulled by its own stiffness and weight during intended use.

7.2.4.4 Reliability of device access

Adequate control of an input device is given when its design prevents unintended loss of control during intended use.

7.2.4.5 Adequacy of device access

The design of an input device shall enable the user to quickly and easily access it (e.g. grasp, position, manipulate) during intended use without adversely affecting performance.

NOTE Positioning of a device depends on its design and the design and adjustment of the workstation and position of the user.

7.2.4.6 Control access

The controls of an input device shall be able to be located and actuated quickly and easily without interference with the overall use of the device.

EXAMPLE Actuating a mouse button does not move the focus of the pointer.

7.2.5 Biomechanical load

7.2.5.1 General

The design of a physical input device shall minimize the biomechanical load of the user. For the purposes of this part of ISO 9241, only postures and muscular effort are considered.

NOTE Some input devices incorporate functionality that helps to reduce static muscle load. This can include a mechanism that measures duration of holding without user actions and gives feedback that reminds the user to adopt a more neutral posture, e.g. with a tactile signal.

7.2.5.2 Postures

An input device shall be operable without undue deviation from a neutral posture during intended use.

NOTE Proper setup of the device as a component of the full workstation is important relative to encouraging neutral postures in the workplace (workstation height, keyboard placement, etc.).

7.2.5.3 Effort

An input device designed for efficient use shall be operable without excessive effort during intended use.

NOTE Proper setup of the device as a component of the full workstation is important relative to encouraging efficient use without excessive effort in the workplace (workstation height, keyboard placement, etc.).

8 Device-specific design requirements

While generic design requirements of this part of ISO 9241 cover aspects applicable to any physical unit that could be used as an input device, some requirements are highly device-specific. Different requirements may apply to the same object if it is designed to be used in another context. For example, while keyboards, mice, trackballs or joysticks can all incorporate buttons in their design, the buttons can serve different purposes. While those on an alphanumeric keyboard are designed for fast typing with ten fingers, a button on a joystick is designed to be pressed by the thumb. Thus requirements can be different depending on the specific device.

The following are treated as device-specific design requirements in this part of ISO 9241:

- functional properties;
- mechanical properties;
- electrical properties;
- maintainability-related properties;
- health- and safety-related properties;
- interdependency with software;
- interdependency with use environment.

9 Documentation

The documentation of a product shall comprise the product description and the operating instructions. The product description shall specify all relevant and usability-related information for selection of the appropriate device.

Since all input devices are operated through some changes in at least one part of the body, relevant information for using them can require dynamic representations (e.g. video clips, animations). Designers are encouraged to select the type of information adequate for the specific information.

Using most devices requires initial learning, but also long-term training in skills. Some devices with potential benefits are not accepted by the user because of information missing on the amount of training needed to achieve a certain level of effectiveness and efficiency. Therefore, the documentation should include information on the timescale for achieving a high level of proficiency.

10 Conformance

The test methods specified in ISO/TS 9241-411 shall be used to assess conformance with the requirements of this part of ISO 9241.

Annex A (informative)

Overview of the ISO 9241 series

This annex presents an overview of ISO 9241: its structure, subject areas and the current status of both published and projected parts, at the time of publication of this part of ISO 9241. For the latest information on the series, see: <http://isotc.iso.org/livelink/livelink?func=ll&objId=651393&objAction=browse&sort=name>.

| Part no. | Subject/title | Current status |
|----------|--|---|
| 1 | General introduction | International Standard (intended to be replaced by ISO/TR 9241-1 and ISO 9241-130) |
| 2 | Guidance on task requirements | International Standard |
| 3 | Visual display requirements | International Standard (intended to be replaced by the ISO 9241-300 subseries) |
| 4 | Keyboard requirements | International Standard (intended to be replaced by the ISO 9241-400 subseries) |
| 5 | Workstation layout and postural requirements | International Standard (intended to be replaced by ISO 9241-500) |
| 6 | Guidance on the work environment | International Standard (intended to be replaced by ISO 9241-600) |
| 7 | Requirements for display with reflections | International Standard (intended to be replaced by the ISO 9241-300 subseries) |
| 8 | Requirements for displayed colours | International Standard (intended to be replaced by the ISO 9241-300 subseries) |
| 9 | Requirements for non-keyboard input devices | International Standard (intended to be replaced by the ISO 9241-400 subseries) |
| 11 | Guidance on usability | International Standard |
| 12 | Presentation of information | International Standard (intended to be replaced by ISO 9241-111 and ISO 9241-141) |
| 13 | User guidance | International Standard (intended to be replaced by ISO 9241-124) |
| 14 | Menu dialogues | International Standard (intended to be replaced by ISO 9241-131) |
| 15 | Command dialogues | International Standard (intended to be replaced by ISO 9241-132) |

| Part no. | Subject/title | Current status |
|--|--|---|
| 16 | Direct-manipulation dialogues | International Standard (intended to be replaced by ISO 9241-133) |
| 17 | Form filling dialogues | International Standard (intended to be replaced by ISO 9241-134) |
| 20 | Accessibility guidelines for information/communication technology (ICT) equipment and services | International Standard |
| Introduction | | |
| 100 | Introduction to software ergonomics | Planned |
| General principles and framework | | |
| 110 | Dialogue principles | International Standard |
| 111 | Presentation principles | Planned to partially revise and replace ISO 9241-12 |
| 112 | Multimedia principles | Planned to revise and replace ISO 14915-1 |
| 113 | GUI and control principles | Planned |
| Presentation and support to users | | |
| 121 | Presentation of information | Planned |
| 122 | Media selection and combination | Planned to revise and replace ISO 14915-3 |
| 123 | Navigation | Planned to partially revise and replace ISO 14915-2 |
| 124 | User guidance | Planned to revise and replace ISO 9241-13 |
| 129 | Individualization | Planned |
| Dialogue techniques | | |
| 130 | Selection and combination of dialogue techniques | Planned to incorporate and replace ISO 9241-1:1997/Amd 1:2001 |
| 131 | Menu dialogues | Planned to replace ISO 9241-14 |
| 132 | Command dialogues | Planned to replace ISO 9241-15 |
| 133 | Direct-manipulation dialogues | Planned to replace ISO 9241-16 |
| 134 | Form-based dialogues | Planned to replace ISO 9241-17 |
| 135 | Natural language dialogues | Planned |
| Interface control components | | |
| 141 | Controlling groups of information (including windows) | Planned to partially replace 9241-12 |
| 142 | Lists | Planned |
| 143 | Media controls | Planned to partially revise and replace ISO 14915-2 |

| Part no. | Subject/title | Current status |
|---|---|---|
| Domain-specific guidance | | |
| 151 | Guidance on World Wide Web user interfaces | International Standard |
| 152 | Interpersonal communication | Planned |
| 153 | Virtual reality | Planned |
| Accessibility | | |
| 171 | Guidance on software accessibility | Under preparation |
| Human-centred design | | |
| 200 | Introduction to human-centred design standards | Planned |
| 210 | Human-centred design of interactive systems | Planned to revise and replace ISO 13407 |
| Process reference models | | |
| 220 | Human-centred lifecycle processes | Planned to revise and replace ISO/PAS 18152 |
| Methods | | |
| 230 | Human-centred design methods | Planned to revise and replace ISO/TR 16982 |
| Ergonomic requirements and measurement techniques for electronic visual displays | | |
| 300 | Introduction to electronic visual display requirements | To be published |
| 302 | Terminology for electronic visual displays | To be published |
| 303 | Requirements for electronic visual displays | To be published |
| 304 | User performance test methods | To be published |
| 305 | Optical laboratory test methods for electronic visual displays | To be published |
| 306 | Field assessment methods for electronic visual displays | To be published |
| 307 | Analysis and compliance test methods for electronic visual displays | To be published |
| 308 | Surface conduction electron-emitter displays (SED) | To be published (Technical Report) |
| 309 | Organic light-emitting diode displays (OLED) | Planned |
| 310 | Pixel defects (visibility, aesthetics and ergonomics) | Planned |
| Physical input devices | | |
| 400 | Principles and requirements for physical input devices | International Standard |
| 410 | Design criteria for physical input devices | International Standard |
| 411 | Laboratory test and evaluation methods for the design of physical input devices | Planned |
| 420 | Selection procedures for physical input devices | Under preparation |

| Part no. | Subject/title | Current status |
|--|---|---|
| 421 | Workplace test and evaluation methods for the use of physical input devices | Planned |
| Workstation | | |
| 500 | Workstation layout and postural requirements | Planned to revise and replace ISO 9241-5 |
| Work environment | | |
| 600 | Guidance on the work environment | Planned to revise and replace ISO 9241-6 |
| Application domains | | |
| 710 | Introduction to ergonomic design of control centres | Planned |
| 711 | Principles for the design of control centres | Planned to revise and replace ISO 11064-1 |
| 712 | Principles for the arrangement of control suites | Planned to revise and replace ISO 11064-2 |
| 713 | Control room layout | Planned to revise and replace ISO 11064-3 |
| 714 | Layout and dimensions of control centre workstations | Planned to revise and replace ISO 11064-4 |
| 715 | Control centre displays and controls | Planned to revise and replace ISO 11064-5 |
| 716 | Control room environmental requirements | Planned to revise and replace ISO 11064-6 |
| 717 | Principles for the evaluation of control centres | Planned to revise and replace ISO 11064-7 |
| Tactile and haptic interactions | | |
| 900 | Introduction to tactile and haptic interactions | Planned |
| 910 | Framework for tactile and haptic interactions | Planned |
| 920 | Guidance on tactile and haptic interactions | Under preparation |
| 930 | Haptic and tactile interactions in multimodal environments | Planned |
| 940 | Evaluation of tactile and haptic interactions | Planned |
| 971 | Haptic and tactile interfaces to publicly available devices | Planned |

Annex B (normative)

Keyboards

B.1 Properties of the keyboard

B.1.1 Functional properties

B.1.1.1 Design of the keys

The functional properties of keys within keyboards (not single buttons) relevant for the usability of a keyboard are

- size (overall),
- keytop shape,
- strike surface,
- displacement,
- force,
- force/displacement characteristic,
- feedback,
- bounce,
- roll-over,
- legend, and
- durability of legends.

B.1.1.2 Sections and zones

A keyboard comprises at least one keypad. More complex arrangements can consist of different keypads, which should be organized in meaningful sections. The following sections are defined in ISO/IEC 9995 (all parts):

- alphanumeric section;
- numeric section;
- editing section;
- function section.

A keyboard may comprise any of these sections, combinations thereof and additional sections and zones. The minimum required number of sections for a keyboard and zones within these sections is determined by the intended use of the keyboard. A maximum arrangement can also be determined by the task, but realization could be restricted by space constraints or other overriding considerations such as portability or fitting into the human hand.

B.1.2 Mechanical properties

Those mechanical properties of a keyboard relevant for usability are

- centreline spacing,
- height,
- width,
- slope,
- profile,
- surface finish,
- weight,
- material,
- thermal conductivity,
- adjustability, and
- palmrest.

B.1.3 Electrical properties

For keyboards that do not require separate power supply, the electrical properties of keyboards are unrelated to usability.

For keyboards with their own power supply, the following usability-related aspects need to be considered:

- influence of cabling (keyboards with external power supply);
- influence of provisions for electrical safety;
- electromagnetic influences on other equipment;
- weight (battery-operated keyboards).

B.1.4 Maintainability-related properties

Maintainability-related properties of keyboards to be considered for usability reasons are the following:

- surface of keytops (cleaning);
- surface of covers required for certain environments (cleaning or keeping free of bacteria in areas with high hygienic requirements).

For keyboards with their own power supply, the following usability related aspects need to be considered:

- dependence of operational characteristics from power supply (voltage and current);
- durability of batteries (battery-operated keyboards);
- indicators for insufficient power supply (e.g. low voltage).

B.1.5 Health- and safety-related properties

The following properties of keyboards need to be considered for safety and health:

- electrical safety (devices with external power supply);
- weight (hand-held devices for continuous operation);
- chemical safety (e.g. fumigation);
- mechanical safety (e.g. sharp edges).

B.1.6 Interdependency with software

Some relevant characteristics of keyboards may be adversely influenced by software.

EXAMPLE 1 Certain application software can slow down the transfer of data from the physical device to the system.

In some cases, using the “generic” driver may degrade the usability of the keyboard.

Like any other control, the functionality of a physical keyboard may be enhanced by adequate software support.

EXAMPLE 2 If the task requires a certain key to be protected against unintended use (e.g. “fat finger error”) the intended protection may be realized

- a) by adequate physical properties of the key and its location within the layout, with the key possibly requiring a higher force to actuate than the adjacent keys and/or being located in a position where it is unlikely to be hit unintended,
- b) by adequate physical properties and software, where the execution of the command initiated by the key is deliberately slowed down and requires holding for a certain time period, and
- c) by software alone, where the execution of the commands initiated by the activation of a key requires confirmation.

Optimizing interdependencies between physical properties of a keyboard and software requires knowledge of the context of use, the task and the user population.

B.1.7 Interdependency with use environment

The operation of a keyboard should be independent from the use environment. The operation of a keyboard can influence the use environment to a certain degree (e.g. through noise) and can be influenced by environmental conditions such as the stability of the support surface and its size or mechanical vibrations affecting the support surface or the user. Both influences can have undesirable effects.

The use of a keyboard can influence the environment through

- noise,
- reflections on the screen,
- occupying free space.

The use of a keyboard can be affected by the following environmental conditions:

- vibrations;
- instability of the support surface;
- lighting (gloss, modelling by multiple shadows etc.).

Both sets of influences can have undesirable effects.

B.2 Design requirements and recommendations

B.2.1 Correspondence with generic design requirements

B.2.1.1 Appropriateness of keyboards

A product may offer different levels of appropriateness. In the case of keyboards, systems integrators or users shall be given information to enable them to select the appropriate device for the task at hand (see Figure B.1).

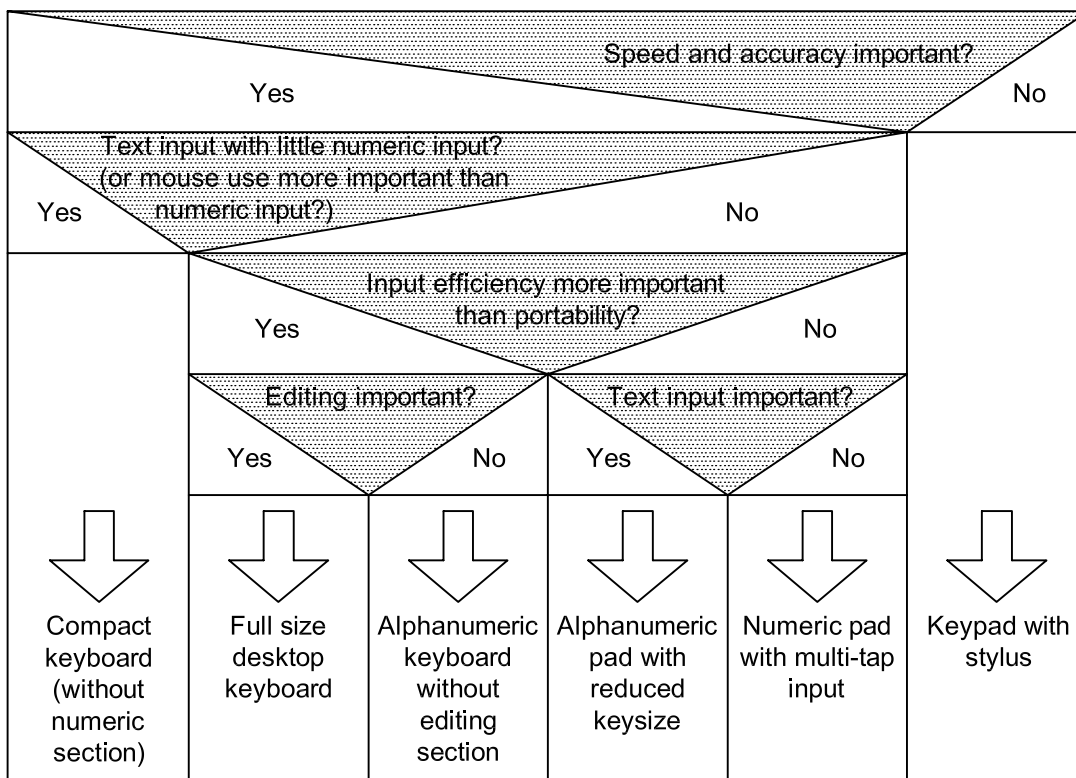

Figure B.1 – Guidance for selecting the appropriate keyboard

If speed and accuracy of the input are not important a keypad with stylus may be appropriate for various reasons (size, weight, space requirement).

For text input with only little numeric input a keyboard with full-size alphanumeric section but without a numeric section is appropriate because it facilitates a more relaxed and neutral mousing position.

A full-size desktop keyboard with all sections according to ISO/IEC 9995 is needed if text and numeric input and the editing of existing data are important. In this case, however, no user will be able to take a position that allows the use of the keyboard and of a mouse while maintaining a neutral posture (see Figure B.2)

If portability is more important than input efficiency the key size may be reduced. If text input is of minor importance a multi-tap numeric pad may be used also for text input.

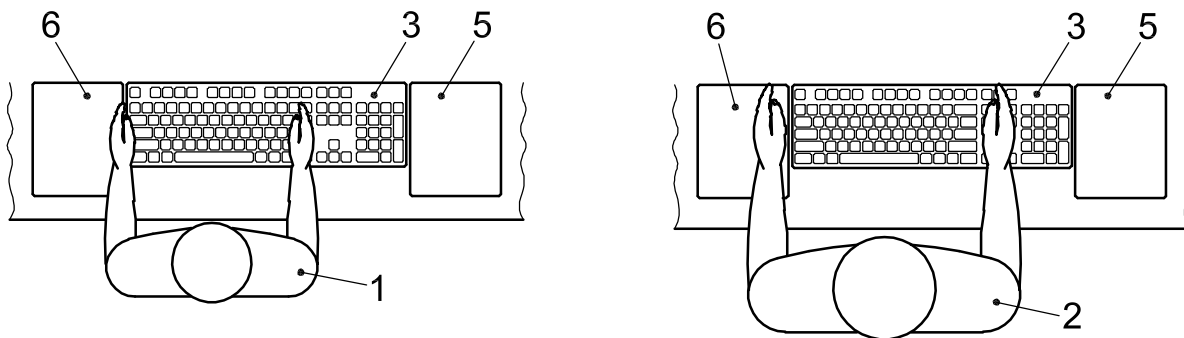

a) Position of full-size keyboard for 5th percentile (female top percentile) and 95th percentile (male bottom percentile) user of European origin

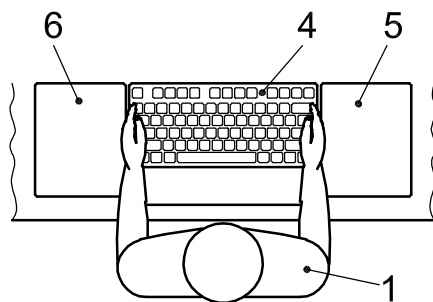

b) Position of compact keyboard for 5th percentile (female bottom percentile) user of European origin with easier access to mouse area

Key

- 1 user of European origin, 5th percentile (female)
- 2 user of European origin, 95th percentile (male)
- 3 full-size keyboard
- 4 compact keyboard
- 5 mouse area for right-hand use
- 6 mouse area for left-hand use

Figure B.2 – Position of a keyboard (optimum for typing)

B.2.1.2 Operability of keyboards

B.2.1.2.1 Obviousness

A keyboard shall either belong to class C1 for obviousness (known or visible without additional instructions and information) or else the required level of instructions shall be specified.

B.2.1.2.2 Predictability

The predictability of key input is achieved if an unintended multiple event, signalled from a single key actuation, is prevented, and if the keyboard detects each key activation in the correct order.

Prevention of the signalling of an unintended multiple event is achieved if the keyboard is provided with either bounce-free switches or a means to ensure that bounce will not cause unintended activation.

Detecting each key activation in correct order is achievable by adequate key roll-over. The required roll-over characteristics depend on the speed of input. Keyboards can be assigned to the following classes characterizing their roll-over abilities:

- C1 unlimited (exceeds maximum throughput for two-hand operation), n -key roll-over or equivalent;
- C2 maximum throughput for 90 % of two-handed input, two-key roll-over or equivalent;
- C3 no roll-over, i.e. first activated key must be released before the subsequent key can be detected;
- C4 delayed input required, i.e. after release of the first activated key, a defined waiting period is needed before the subsequent key can be detected.

Keyboards shall either belong to class C1 or else the class to which they belong shall be specified.

B.2.1.2.3 Consistency of operation of keyboards

There is consistency of operation if the effectiveness does not change under different situations belonging to the intended context of use. The feedback given shall be the same for the intended context of use. This means that the effectiveness and the feedback will not be changed under conditions for which a certain variation is allowed (e.g. a temperature range).

As for compatibility, a keyboard shall either belong to class C1 (enables maximum throughput and accuracy for two-handed operation) or else the restricted level shall be specified.

B.2.1.2.4 Compatibility of keyboards with biomechanical capabilities

The most important property of keyboards for accommodating the anthropometric characteristics of a user population is the centreline spacing, i.e. the distance of adjacent keys measured from centre to centre. For fast touch typing, which needs prior training and long-term experience, it is important to have the same spacing for all systems that accept fast and continuous input from keyboards. This spacing is set to 19 mm by convention.

NOTE Certain keys can occupy more than one position in the grid and thus the 19 mm centre-to-centre restriction might not be applicable vertically or horizontally, nor in either direction (see ISO/IEC 9995-1).

Certain user populations with special needs can require a greater distance, while 19 mm could be too wide for others such as children). A distance greater than 19 mm can also be required for certain environments (e.g. cold environments where users need protective equipment or unstable environments such as cars, aeroplanes or trains).

There are a variety of reasons for using smaller centreline distances for keys, thus also for using smaller keys. Portability of a device with an integrated keyboard is one such reason; fitting a device into the human hand is another. Currently, there are no established ergonomic rules for establishing an acceptable compromise between them.

For the spacing of the keys, the following group categories apply for the adult user population:

- G1 fully compatible for adult user population, 19 mm;
- G2 restricted maximum achievable level for effectiveness 90 % and efficiency 90 %, 14 mm;
- G3 restricted maximum achievable level for effectiveness 80 %, efficiency 80 %, 12 mm;
- G4 use requires additional aids (e.g. stylus) and or special forms for keys, less than 10 mm.

For users with small hands (e.g. children, women with hand-size below the 5th percentile), keys with smaller spacing (pitch) can be beneficial. Such keyboards have a spacing between G2 and G3.

With very young children who have less precise motor control, larger keys (more than 19 mm) can be better suited. Such keyboards are also beneficial for other users who have lost some precision of their motor control, such as elderly users. Where it is not possible to use key spacing other than 19 mm, the use of an additional mechanical guide for the fingers can help to compensate for some loss of motor control. Such guides may also be beneficial in environments where typing is affected by vibration.

B.2.1.2.5 Feedback

Feedback from a keyboard can be visual, kinaesthetic, auditory or a combination of these. The feedback can be given partly by other components of the system using the signal generated by the keyboard.

The characteristics of feedback required for usability depend on the specific task. The fastest detectable feedback for keying is kinaesthetic feedback, while visual feedback on a secondary device can be the slowest and least effective. Kinaesthetic feedback is also the most effective and efficient because it gives continuous information on the actuation and activation of a key, whereas auditory and visual feedback indicate activation only.

Feedback can be categorized into four classes:

- C1 continuous kinaesthetic feedback sufficient for two-handed touch typing;
- C2 ramp action and auditory feedback;
- C3 auditory feedback;
- C4 delayed visual feedback.

B.2.1.3 Controllability of keyboards

The responsiveness of a keyboard is given if the feedback following its actuation is consistent and accurate to the same degree.

EXAMPLE Activating a graphic key is always accompanied by a generated character on the screen and by a tactile feedback which is the same for all keys on that keyboard.

The responsiveness of a keyboard can be changed by software. Reliable access to a keyboard designed to be used while resting on a support surface is given if user actions during intended use cannot cause it to slip or rock. For the adequacy of device access, detachable keyboards shall be designed so as to be easily repositioned on the support surface.

For hand-held devices, controllability is given if the required level of effectiveness and efficiency can be achieved without the aid of a support surface for the device and/or upper extremities.

Adequate control access for a keyboard designed to be used while resting on a support surface is given if it is detachable and fulfils the requirements for the mechanical design of keyboards (see B.2.3).

Adequate control access for a keyboard designed for hand-held operation is given if the required effectiveness can be achieved under consideration of the compatibility with the biomechanical capabilities of the intended user population and the user can operate the keyboard without losing contact to the display.

B.2.2 Requirements for functional properties

B.2.2.1 Requirements for the design of keys

B.2.2.1.1 Requirements for full-size keyboards

The requirements a) to m), below, apply for full-size keyboards for which (see also Figure B.1)

- speed and accuracy are important,
- mouse use is less important than numeric input,
- input efficiency is more important than portability,
- editing is important,
- there is C1 operability (exceeds maximum throughput for two-hand operation), and
- there is C1 user compatibility (adult user population).

a) Keytop shape

The keytops of normal-size keys in the alphanumeric, cursor and numeric zones shall have either concave or flat strike surfaces. The space bar may be flat or convex.

b) Strike surface

The strike surface of the keytops of alphanumeric keys shall be at least 110 mm² in area, and between 12 mm and 15 mm in width. The minimum strike surfaces apply to the keys in the alphanumeric and numeric zones. Outside these sections, strike surfaces may be smaller, but not less than 64 mm².

NOTE The appropriate dimensions of the keytop (keycap) depend on the key width and key centre spacing, as well as the strike surface and the key displacement.

Tactile indicators should be provided on the appropriate keys on the home rows of the alphanumeric zones (i.e. position C04 and C07 according to ISO/IEC 9995-1) and numeric zones (i.e. C52 according to ISO/IEC 9995-1).

c) Displacement

The key displacement shall be between 1,5 mm and 6,0 mm. The preferred key displacement is between 2,0 mm and 4,0 mm.

d) Force

The force at the character generation point or at the snap point should be between 0,5 N and 0,8 N and shall be between 0,25 N and 1,5 N.

e) Force/displacement characteristics

For displacement keyboards (see Figure B.3), the initial resistance (starting force or preload) shall be between 25 % and 75 % of the force at the character generation point (for ramp action) or snap point (for snap action). The switch-make action in the snap action shall occur after the snap point but before the key force has returned to the snap point. The activation should occur around the minimum force point after the snap point.

The force/displacement characteristics across the alphanumeric keys should be consistent. The force/displacement characteristics of a key should not depend on the part of the strike surface hit while actuating.

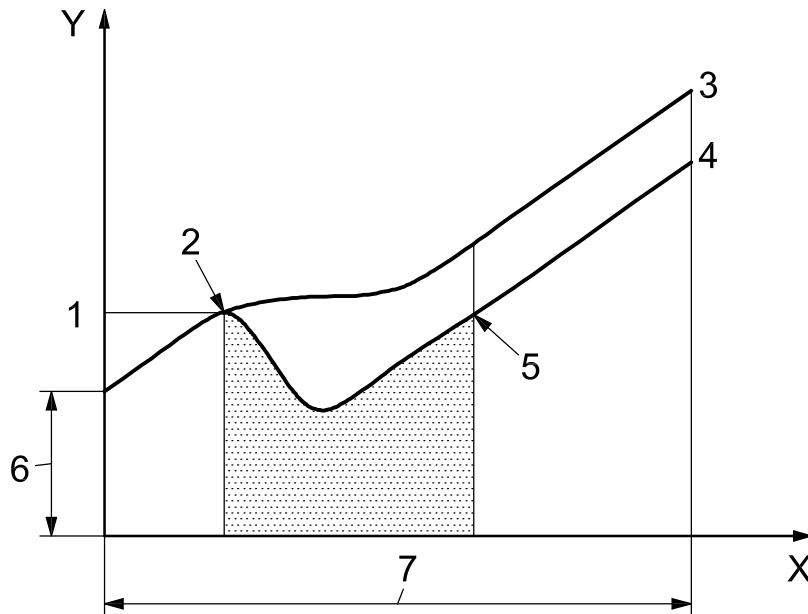

Key

- X travel, mm
- Y force, N
- 1 force at snap point — between 0,5 N and 0,8 N (preferred), 0,25 N and 1,5 N (permitted)
- 2 snap point
- 3 ramp action
- 4 snap action
- 5 switch-make point occurs — after snap point, at force \leq snap point
- 6 initial resistance — between 25 % and 75 % of force at snap point
- 7 full travel — 2 mm to 4 mm (preferred), 1,5 mm to 6 mm (permitted)

Figure B.3 – Relationship between key displacement and key force

f) Feedback

Actuation of a key shall be accompanied by feedback. Feedback can be kinaesthetic, auditory or some combination of the two. If the design allows for only one means of feedback, then kinaesthetic feedback is preferred.

Ramp action displacement alone does not provide sufficient tactile feedback and should be accompanied by auditory feedback.

Auditory feedback should be provided whenever tactile feedback is not provided. If the principal means is auditory, the auditory signal shall be perceptible in the use environment. The auditory signal should be an impulse sound (e.g. click of a relay switch) or tone (e.g. bell or beep sound). Supplementary auditory feedback shall be suppressible (i.e. a volume control position that represents “off”). The feedback shall occur within 100 ms after the key activation.

Visual feedback should be used to indicate the long-term status of a particular key or keys (e.g. shift, mode state). Such feedback should be clearly visible to the user. Visual feedback may be given by the key itself or the keyboard, in which case it should be adjacent to or in close proximity to the key. In the case of feedback appearing on the screen (e.g. in an operator information area) it should clearly indicate which state the key or keys are in.

g) Bounce

In order to prevent unintended multiple event signalling from a single key actuation, the keyboard shall be provided with either bounce-free switches or a means of ensuring that bounce will not cause unintended activation.

h) Key repeat function

Where a repeat function is provided, the fixed repeat rate shall be 10 activations per second to 20 activations per second after an initial delay of between 500 ms and 750 ms after the key is actuated. If the repeat function is activated by a higher pressure force upon the key, the delay may be reduced.

NOTE Initial delays of greater than 750 ms are likely to be perceived as too long.

A user-adjustable repeat rate is preferred.

For certain irreversible functions (e.g. "erase" command) the repeat action facility should be suppressible.

i) Key rollover

Keyboards designed for stationary use shall be equipped with *n*-key rollover according to C1 (see B.2.1.2.2). Alternatively, any means ensuring that each key activation is detected in correct timely order may be used.

j) Geometric design of key legends

All legends on keys shall be legible from the design reference posture (see ISO 9241-5). The height of primary legends on an alphanumeric key shall not be less than 2,6 mm. When a graphical symbol, a full word or a well-established abbreviation is used, the height shall not be less than 2,2 mm. The width of the capital letters (excepting I and W) shall be between 50 % and 100 % of the height. The ratio between the height and stroke width should be between 5:1 and 14:1. For primary legends on all keys, the luminance contrast between the luminance level of the background and the legends shall be a minimum of 3:1. Secondary legends should be perceptually different from the primary legends on the same key. Legends should appear to have a sharp outline. Dark characters on a light background are recommended for bright environments.

k) Graphical symbols

Where graphical symbols are used, these shall be in accordance with ISO/IEC 9995, and with ISO 7000 and IEC 60417-DB, as applicable.

l) Number and positioning of legends

The number of legends on any key should be kept to a minimum. The positioning of the legends shall be in accordance with ISO/IEC 9995-1, as applicable.

Where legends are too long for the keytop or where the function of the keys can change (e.g. emulation), key legends may be provided on an overlay. Where legends are provided on overlays or the keyboard housing, they should be adjacent, or in close proximity, to the keys to which they refer. If space does not allow for the implementation of this recommendation, a reference card should be provided. Overlays and reference cards shall have a matt finish.

Some keyboards incorporate individual displays for each key. In this case, it shall be possible to label the re-legendable key with appropriate information about the content programmed into the key.

m) Durability of legends

Legends shall be legible throughout the intended life of the product. They shall be robust and durable so that they are able to withstand normal wear and usage, including regular cleaning.

NOTE Currently, the intended life of desktop keyboards is calculated for continuous keying of the E key over the workday during the full life-span of the product, assuming the approximate occurrence of this character in European languages.

B.2.2.1.2 Requirements for compact keyboards

The requirements for the design of the keys for compact keyboards shall be the same as those specified for full-size keyboards in B.2.2.1.1, a) to l). The requirements related to the durability of legends are as follows.

Legends shall be legible throughout the intended life of the product. They shall be robust and durable so that they are able to withstand normal wear and usage, including regular cleaning.

If the device is designed to be used as an equivalent replacement for a full-size keyboard, the intended life of the product shall be the same as that for the full-size keyboard. For devices designed to be integrated in portable units (e.g. laptop computers), a less intensive use for keying may be assumed.

NOTE Currently, the intended life of desktop keyboards is calculated for continuous keying of the E key over the workday during the full life-span of the product, assuming the approximate occurrence of this character in European languages.

B.2.2.2 Sections and zones

B.2.2.2.1 Requirements for full-size keyboards

A full-size desktop keyboard shall comprise all the sections and zones defined in ISO/IEC 9995:

- alphanumeric section;
- numeric section;
- editing section;
- function section.

The principal sections of a keyboard as defined in ISO/IEC 9995-1 shall be perceptually differentiated. This may be accomplished by a spatial vertical and horizontal separation by at least half a key pitch or by visual differentiation.

B.2.2.2.2 Requirements for compact keyboards

A compact keyboard shall comprise the following sections and zones as defined in ISO/IEC 9995-1:

- alphanumeric section;
- editing section;
- function section.

The principal sections of a keyboard as defined in ISO/IEC 9995-1 shall be perceptually differentiated. This may be accomplished by a spatial vertical and horizontal separation by at least half a key pitch or by visual differentiation. Spatial grouping of the keys of the function section is not required.

B.2.3 Requirements for the mechanical design of keyboards

B.2.3.1 Requirements for full-size keyboards

The requirements a) to m), below, apply for keyboards for which (see also Figure B.1)

- speed and accuracy are important,
- mouse use is less important than numeric input,

- input efficiency is more important than portability,
- editing is important,
- there is C1 operability (exceeds maximum throughput for two-hand operation), and
- there is C1 user compatibility (adult user population).

a) Centreline spacing

The layout of the keys shall conform to ISO/IEC 9995. The horizontal and vertical distances between two adjacent keys in the alphanumeric and the numeric zones measured centre to centre shall be $19 \text{ mm} \pm 1 \text{ mm}$. Outside the alphanumeric and numeric zones, other centreline spacings are permitted, but should not be smaller than 15 mm.

NOTE Certain keys can occupy more than one position in the grid and thus the 19 mm centre-to-centre restriction might not be applicable vertically or horizontally, nor in either direction (see ISO/IEC 9995-1).

b) Home row height

The preferred home row height is as low as possible and not greater than 30 mm. However, the home row height of the keyboard shall not exceed 35 mm. If an adjustment mechanism is provided, there shall be at least one adjustment that allows it to comply with the height specification.

c) Width and depth

For the purpose of achieving efficient use of the keyboard, the overall size of a device shall be determined in consideration of the number of keys needed and their adequate grouping in sections and zones. Following the concept of minimum footprint, the size of a keyboard should be limited to the space required to achieve the intended functionality.

Since most keyboards are likely to be used together with a mouse by right-handed persons, the keyboard housing should not extend further to the right than is required by mechanical considerations.

The overall depth of a keyboard is less critical than the width, given that flat monitors offer more freedom to positioning the keyboard. However, on workplaces with restricted space, the depth can be critical for usability and it is therefore beneficial to keep the depth of the keyboard as small as possible.

d) Slope of keyboard

The recommended slope is 0° to 12° positive to the horizontal. The slope of the unadjusted keyboard shall be between 0° and 15° positive.

e) Profile of keyboard

The profile of the keyboard may be sloped, dished, stepped, sculptured or flat.

f) Keyboard surfaces and material properties

The visible surfaces of the keyboard shall be matt-finished. The finish of the surfaces should not exceed silky matt (corresponding to 45 gloss units or to a 60° reflectometer value of less than 20), in order to minimize specular reflections.

For lighted environments, the diffuse reflectance of the keyboard should have values of between 0,15 and 0,75, in order to avoid undue luminance contrast to the equipment and other items within the field of view (see ISO 9241-5:1998, 5.4.4).

There should be no sharp edges or corners on the keyboard that could cause injury or discomfort to users. The minimum radius at edges and corners on the keyboard housing should be 2 mm with a larger radius at the corners.

g) Numeric keypad

The ten digits zero to nine shall be allocated to keys in the numeric section in one of two ways: either in the form of the 1-2-3 (telephone) layout or the 7-8-9 (calculator) layout. The telephone layout is recommended.

NOTE Layout and allocation of the numeric section is specified in ISO/IEC 9995.

h) Cursor keys and keys in the editing section

Keys for the control of cursor movement shall be provided.

NOTE Positioning of the cursor keys is covered by ISO/IEC 9995.

Keys which activate erase or delete functions should be positioned so that inadvertent activation is prevented.

i) Weight

It should be noted that the weight of the device can be relevant for the usability of the product (prevention of unintended movement and slipping).

j) Material

Material properties of keyboards for stationary use are relevant in respect of thermal conductivity and wear and tear [for durability of legends, see A.2.2.1.1 m].

k) Thermal conductivity

The material of the surface with which the user frequently comes into contact should not have unfavourable heat conductivity characteristics.

l) Adjustability

The keyboard slope should be adjustable. Any adjustment mechanism shall not compromise the requirements for stability and placement. Adjustments shall not be able to be made unintentionally. Tools shall not be required for adjustment purposes.

NOTE Support surfaces or other mechanisms designed for the purpose of placing or holding keyboards (e.g. keyboard trays that provide x, y and z and slope adjustments) are subject to the design provisions given in ISO 9241-5.

m) Palmrest

If the design includes a palmrest then a depth of 50 mm to 100 mm should be provided in front of row A.

Where a palm-rest is not provided, the area in front of row A should be as near as possible to the front edge of the keyboard.

B.2.3.2 Requirements for compact keyboards

The requirements a) to l), below, apply to keyboards for which (see also Figure B.1)

- speed and accuracy are important,
- mouse use is more important than numeric input,
- input efficiency and portability are important,

- editing is important,
- there is C1 operability (exceeds maximum throughput for two-hand operation), and
- there is C1 user compatibility (adult user population).

The allocation of key positions to functions may be organized in deviation from ISO/IEC 9995-1. The keys of the editing section should be positioned to the right of the alphanumeric section or in front of it on the right side (see Figure B.4).

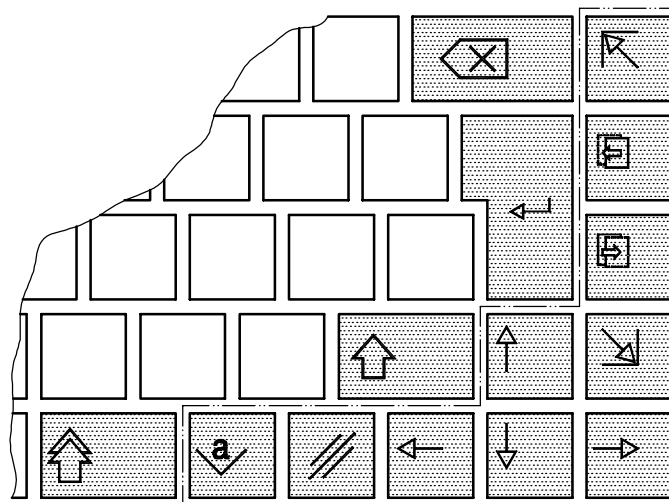

Figure B.4 – Position of the editing section

a) Centreline spacing

The horizontal and vertical distances between two adjacent keys in the alphanumeric zone and, if present, the numeric zones, when measured centre-to-centre shall be $19\text{ mm} \pm 1\text{ mm}$.

NOTE Certain keys can occupy more than one position in the grid and thus the 19 mm centre-to-centre restriction might not be applicable vertically or horizontally, nor in either direction (see ISO/IEC 9995-1).

b) Home row height

The keyboard should be as low as possible and have a preferred home row height not greater than 30 mm. The home row height of the keyboard shall not exceed 35 mm.

c) Width

To achieve efficiency for the use of the keyboard, the overall size of a device shall be determined in consideration of the number of keys needed and their adequate grouping in sections and zones. Following the concept of minimum footprint, the size of a keyboard should be limited to the space required to achieve the intended functionality. For this purpose, the editing section of the keyboard is integrated closely to the alphanumeric section.

d) Slope

For the slope of compact keyboards, the provisions of B.2.3.1 d) for full-size keyboards apply.

e) Profile

The profile of the keyboard may be sloped, dished, stepped, sculptured or flat.

f) Keyboard surfaces and material properties

For the visible surface and material properties of compact keyboards, the provisions of B.2.3.1 f) for full-size keyboards apply.

g) Cursor keys and keys in the editing section

Keys for the control of cursor movement shall be provided. These keys can be organized as shown in Figure B.4 if the editing section is integrated into the alphabetic section.

Keys which activate erase or delete functions should be positioned so that inadvertent activation is prevented.

h) Weight

It should be noted that the weight of the device is directly relevant for products designed for portability and use on stable surfaces. The weight of the device may also be relevant for the usability of the product (in preventing unintended movement and slipping).

i) Material

Material properties of compact keyboards are relevant regarding thermal conductivity and wear and tear.

j) Thermal conductivity

For the thermal conductivity of compact keyboards, the provisions of B.2.3.1 k) for full-size keyboards apply.

k) Adjustability

For the adjustability of compact keyboards, the provisions of B.2.3.1 l) for full-size keyboards apply.

l) Palmrest

For the palmrest of compact keyboards the provisions of B.2.3.1 m) for full-size keyboards apply.

B.2.4 Electrical properties

B.2.4.1 Requirements for full-size keyboards

Desktop keyboards receive their power either through a low voltage cable from the computer or parts of it, or through (mostly) rechargeable batteries. Provisions for electrical safety can interfere with usability aspects in exceptional cases only.

Cables attached to physical input devices should be located or attached to the input device such that they do not interfere with use. The weight, flexibility, tension, and attachment location of the cable and the potential for it to become entangled should be taken into account when designing cabling.

Cabling of any kind occupies a certain part of desk space and forms a potential obstruction for the case when the occupied space is needed for other devices or activities. The interference of cabling with usability can be reduced by appropriate design of the device and/or the cable itself.

The categories for the design of the device are (see Figure B.5)

- C1 no cable needed,
- C2 cable can be plugged in at different locations on the keyboard as needed at a particular workplace,
- C3 cable connected at the middle of the device, and
- C4 cable connected at one end of the device.

The design of the cable can interfere with the space if the cable is, for example, too thick, too stiff or too long (see Figure B.6).

The categories for the design of the cable are

- C1 no cable needed,
- C2 thin, flexible cable,
- C3 spiral cable with the spiral end at the keyboard, and
- C4 cable thick or inflexible due to other considerations.

Electromagnetic influences on other equipment used at the same workstation may be considered irrelevant, owing to regulations for electromagnetic compatibility.

The additional weight of batteries of keyboards for stationary use is not relevant for usability.

A loose cable with a plug on both ends can facilitate maintenance and replacement/change of the keyboard.

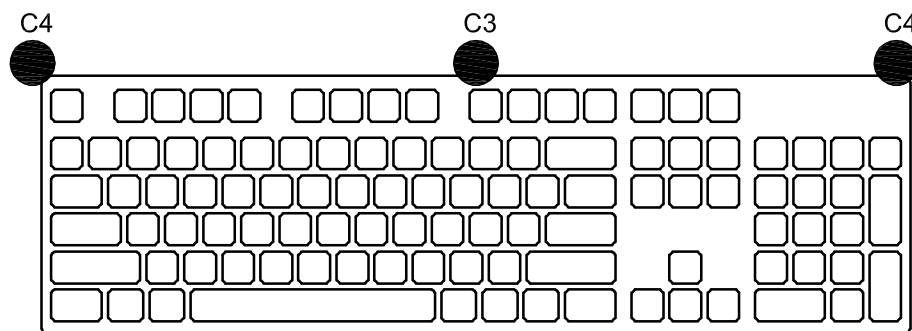

Key

- C3 cable connection in middle of device
- C4 cable connection at one end of device

NOTE While C2 allows the connection of cable for minimum interference with space, in C3 the connection is at the middle of the keyboard and in C4 only one of the connections at either end of the keyboard is used.

Figure B.5 – Possible cable connections of a keyboard



The cable can interfere with the space if, for example, too thick, too stiff or too long

Figure B.6 – Cables categorized for possible interference with other devices on the desktop

B.2.4.2 Requirements for compact keyboards

For the electrical properties of compact keyboards designed to be used as separate units, the same provisions as for stationary keyboards apply (see B.2.4.1). For compact keyboards integrated into the design of another device (e.g. portable computer), no separate considerations for electrical properties are given in this part of ISO 9241.

B.2.5 Maintainability-related properties

B.2.5.1 Requirements for full-size keyboards

In certain areas, the easy cleaning of keytops can be an important consideration, for example, for reasons of hygiene and where a smooth keytop surface is required. Where such requirements exist, the finish of the keytops is not required to be matt.

The impairment of visibility through gloss can be reduced by adequate lighting. In some environments, the entire keyboard will need to be covered, e.g. for hygienic reasons. Any interference of the cover with the efficiency and effectiveness of typing and the visibility of important parts of the keyboard (legends, active indicators, etc.) should be minimized.

If the operational characteristics of a battery-operated keyboard can be adversely affected by an insufficiency in the power supply, there shall be an easily detectable indication of the battery power status (e.g. indicator lamp, alarm sound or a mechanical indicator).

The durability of the batteries and their electrical characteristics shall be such that they ensure the user can complete the last actions after being warned without high time pressure. The keyboard should function properly for at least 5 min after the indication of the battery status.

B.2.5.2 Requirements for compact keyboards

Maintainability-related requirements for compact keyboards designed to be used as separate devices do not differ from those for keyboards designed for stationary use.

Compact keyboards integrated into another device receive their power from that device, and no specific requirements associated with usability apply.

B.2.6 Health- and safety-related properties

SAFETY PRECAUTIONS – Keyboards should not contain, nor be made of, materials known to cause health and safety problems through skin contact or emissions.

B.2.6.1 Requirements for full-size keyboards

The electrical safety of computer equipment in general is specified in other International Standards (e.g. IEC 60950 [14]).

B.2.6.2 Requirements for compact keyboards

As computer equipment, the electrical safety of compact keyboards is specified in other standards (e.g. IEC 60950 [14]).

The weight of the keyboard can be relevant for the comfort of carrying portable units; no requirement can be given based on usability considerations.

Compact keyboards integrated into another device (e.g. portable computer) generally do not contribute significantly to the weight of that device.

B.2.7 Documentation

B.2.7.1 General

Keyboard documentation shall indicate whether the following is needed to achieve the intended level of usability (effectiveness, efficiency and satisfaction):

- special training;
- additional physical tools;
- specific software support.

B.2.7.2 Requirements for full-size keyboards

Keyboards designed for stationary use (full-size keyboards) form a group of products with world-wide distribution. Thus, training needed for their efficient use is not considered “special training”. There is no need for the documentation to specify user training.

The use of these products does not require additional physical tools for the sole purpose for which they have been designed (alpha-numeric input). There is also no need for the documentation to specify other physical tools.

The documentation (see Clause 9) shall indicate the need for specific software support if needed to achieve the intended level of effectiveness and efficiency.

B.2.7.3 Requirements for compact keyboards

For compact keyboards, the same requirements for the documentation as for full-size keyboards apply.

B.2.8 Interdependency with software

B.2.8.1 Requirements for full-size keyboards

This part of ISO 9241 does not give requirements concerning the interdependency between the physical characteristics of a keyboard and software, since the optimization of such interdependency is highly dependent on the context of use, e.g. task and user population. This does not mean that the interdependency is low or insignificant. The opposite is the case, as shown by the efforts of manufacturers, both in the past and in recent years, to optimize the use of their software by changing the design of the keyboard. However, there is insufficient knowledge to be included in an International Standard.

The most obvious and annoying effect of the interdependency between keyboard and software is the reduction of throughput below the individual speed of a user. However, this effect is mostly caused by the application software.

EXAMPLE A spreadsheet that performs calculations during input or a layout program that continuously recalculates page breaks during text input.

B.2.8.2 Requirements for compact keyboards

Compact keyboard design differs from that of full-size desktop keyboards mainly through the integration of the editing section in the space occupied by the alphanumeric section and its neighbourhood. Some keys might be smaller than those on the full-size keyboard (e.g. cursor keys). And the numeric section could be missing. Thus, some activities (e.g. navigating with the cursor) can be less effective and efficient.

However, working with software based on operating systems with graphical user interfaces improves this situation, as the use of an additional input device — generally a pointing device, most often a mouse — is improved. Since the compromise entailed requires consideration in respect of the application software but not of the design of the keyboard, there are no specific requirements.

NOTE Problems can occur with software that utilizes keys that are duplicated in the numeric section, such as =, *, -, + or /, in different contexts of meaning than those in the other sections.

B.2.9 Interdependency with use environment

B.2.9.1 Requirements for full-size keyboards

In many use environments, the keyboard generates more, and continuous, noise than devices such as printers that are active for a short period of the working day. In noisy environments, however, the keyboard noise may be hardly perceptible. For this reason, no single limit for the noise emission of keyboards can be justified from an ergonomic point of view, but the noise emission should be as low as possible without compromising the usability of the keyboard.

The noise emission can be categorized in consideration of the intended application area and its typical ambient noise levels (see ISO 9241-6). The classes can be determined by the noise exposure data of ISO 11690-1:

- C1 suitable for meeting rooms or tasks involving concentration [35 dB(A) to 45 dB(A)];
- C2 suitable for routine office work [45 dB(A) to 55 dB(A)];
- C3 suitable for industrial workplaces [75 dB(A) to 80 dB(A)].

The data in square brackets in the list is the recommended maximum noise exposure range.

NOTE 1 There is no C4 because ISO 11690-1 specifies only three levels of noise exposure. There is a much finer specification of the noise exposure in that International Standard, but it seems unrealistic that keyboards can be produced and marketed to be suitable for seven or eight levels of noise exposure.

NOTE 2 Acoustic feedback from keyboards is not considered “noise” because it can be a functional requirement. However, it still can be annoying to persons not involved in the use of the device (e.g. colleagues in shared office space).

Reflections of the keyboard on the screen as a form of interdependency with the environment can occur in most environments. However, they will remain unnoticeable in most cases. In dark environments, such reflections may annoy users. For specific tasks where the correct identification of colours is essential to the task, the effectiveness of work may be impaired.

In environments where reflections of the keyboard on the screen could be an annoyance or even the cause of a loss of effectiveness, dark keyboards should be used.

The keyboard occupies a considerable part of the work surface in front of the user, and for proper operation it needs to be located in close reach of the user. Remedies can be found either by appropriate organization of the work place (see ISO 9241-5) or by the design of the device. The provisions given in B.2.2 are formulated to give guidance for reducing the required space without compromising the usability of the device. The guidance given in Figure B.1 is formulated to help finding the appropriate keyboard for limited space.

Vibrations and instability of the support surface are factors that influence the operation of a keyboard. Both will reduce the throughput, increase errors and biomechanical load. For the design of keyboards for stationary use, it may be assumed that vibrations are limited to an extent that the interference is not significant. In addition, it may be assumed that the support surfaces are stable enough for effective and efficient keyboard operation.

NOTE 3 Errors or reduced throughput can be compensated by appropriate software.

Lighting can interfere with keyboard use if the surfaces are not matt. Therefore, it is a requirement of this part of ISO 9241 (see B.2.3.1) that the keyboard surfaces be matt-finished. In cases where surfaces cannot be matt-finished, appropriate lighting-related measures outside the scope of this part of ISO 9241 may be taken (see ISO 9241-6).

Directional light can also interfere with keyboard use by modelling the surface appearance in a certain way. Since this interference can occur under certain circumstances, no general recommendation can be given for the design of the device.

B.2.9.2 Requirements for compact keyboards

Requirements for compact keyboards are the same as for full-size keyboards. When using a compact keyboard as a portable device, it is recommended that the noise emission fulfil the requirements for C1 (suitable for meeting rooms or tasks involving concentration [35 dB(A) to 45 dB(A)]).

For reflections on the screen, the same requirements as for full-size keyboards apply.

Compact keyboards are affected by vibrations and instability of the support surface either to the same extent as full-size keyboards (used on stationary support surfaces) or even to a greater extent during mobile use. Possible remedies are mechanical guides similar to those designed for users suffering from spasticity or software with improved abilities in filtering and correcting mistyped words. Presently, there is no justification based on scientific research for a standard on the design of devices.

The interference with lighting during the use of compact keyboards will occur to the same extent as with full-size keyboards in organized workspaces. However, in portable use, the problems can occur more often, since the characteristics of lighting are likely to be less favourable. For example, spotlights or halogen bulb lamps cause more annoying reflections on keyboards than fluorescent lamps used in office lighting. The requirements resulting from this are a matt surface for the design of the product and often cleaning for use. Reflections are less annoying when the diffuse reflectance of the keyboard is high.

Annex C (normative)

Computer mice

C.1 Properties of the mouse

C.1.1 Functional properties

The functional properties of the mouse are related to the following:

- anchoring the body parts needed for holding and controlling the device on the device or on the work surface;
- locating the pointer correctly at the intended target;
- target acquisition.

The relevant properties for anchoring are the mechanical design of the housing and the buttons. For locating the pointer, the resolution and consistency of resolution are important. For target acquisition, the location of the sensor, the dynamic properties of the button (motion, actuation and the interference of the actuation with the control of the device) are also important.

C.1.2 Mechanical properties

Those mechanical properties of a mouse relevant for usability are

- shape, profile (two directions),
- friction on the supporting surface (how it changes, e.g. when it collects dirt, flexibility of the cable),
- size (length, width, height),
- surface, friction in hand,
- buttons (position, shape, force, feedback),
- wheel (resistance, “bumps”, position, height, diameter, width), and
- feedback (vibration, sound, force).

C.1.3 Electrical properties

Those electrical properties of a mouse relevant for usability are

- cabling,
- electromagnetic influences on the environment caused by the device, and
- batteries, if included.

C.1.4 Maintainability-related properties

Maintainability-related properties relevant for usability are

- cleaning the device or parts of it, and
- the power supply for battery-operated mice.

C.1.5 Health- and safety-related properties

The following are properties of mice that need to be considered for the user's health and safety:

- electrical safety (devices with external power supply);
- weight (hand-held devices for continuous operation);
- chemical safety (e.g. fumigation);
- mechanical safety (e.g. sharp edges).

C.1.6 Interdependency with software

The operation of a mouse is highly software-dependent. Normally, the user is allowed to introduce some relevant changes into the software that can considerably change the usability of the device. The most important change users can make is adjusting gain to suit his or her personal preferences.

The mouse is usually delivered with, and operated by means of, own-software that supports its entire functionality, or else it is operated with the aid of a "generic" mouse driver that might possibly provide it with only limited capabilities.

Specific software can help to overcome limited abilities of the user.

EXAMPLE Most people are unable to draw a straight line regardless of the device they use (pen, stylus or mouse). The electronic equivalent of a mechanical ruler enables even people with very limited drawing ability to draw straight lines more precisely than skilled draughtsman and highly independent of the environment (e.g. in shaky vehicles).

C.1.7 Interdependency with use environment

The use of a mouse is unlikely to influence the environment of the workplace except for the noise of clicking.

The use of a mouse can be particularly affected by the following environmental conditions:

- vibrations;
- size and location of the available free space;
- instability of the support surface;
- surface characteristics of the support surface;
- dust and dirt.

C.2 Design requirements

C.2.1 Correspondence with generic design requirements

C.2.1.1 Appropriateness of the mouse

Since mice are pointing devices designed to be controlled by the hand and the lower arm, an appropriate general purpose design is recommended to enable users to achieve the maximum throughput for these limbs. Mice can achieve a task precision corresponding to C1 (index of difficulty greater than 6, see C.2.2.2).

No conclusive knowledge exists on the compatibility of the mouse in respect of the anthropometric dimension of the intended user population. For this reason, no requirements are given in part of ISO 9241. However, the design of the mouse should take into consideration neutral finger and wrist postures for different anthropometric percentiles, while keeping muscle forces low and minimizing static work load.

NOTE While a certain property of a design (e.g. length) can help improve posture to a certain degree (less wrist extension) the same design can also reduce effectiveness and efficiency of use. Some mice are twice the size of others or are much higher than comparable products. Conventional wisdom (dimensioning for a certain percentage of the user population) does not help much, since a number of anthropometric measures are involved (length and width of palm, length of the fingers involved, etc.) as well as a number of design parameters such as length, width and height of the mouse, number and location of buttons, and use of mouse pad.

For these reasons, no requirements on appropriateness are given in this part of ISO 9241.

C.2.1.2 Operability of the mouse

The obviousness of mouse operation can be categorized into four classes:

- C1 known or visible without the need for additional instructions and information;
- C2 detectable by the user by trial and error;
- C3 learnable by means of simple instructions;
- C4 learnable by means of special training.

C2 can be achieved for general-purpose devices and novice users. For C3 and C4 devices, the relevant information shall be included in the documentation. The predictability of the pointer's movement on the screen in the cardinal directions can be assumed if the user can sense the orientation of the device without visual contact and if the device does not move unintentionally when the user loosens his/her grip (see Figure C.1).

Regarding consistency of operation (device operates and responds in the same manner) mice can be categorized as follows:

- C1 independent of the characteristics of the support surface;
- C2 operable on any smooth surface;
- C3 operation requires a mouse pad;
- C4 operation requires a mouse pad with specific characteristics.

If the cable is thick and heavy in respect of friction on the support surface, the mouse will be likely to turn each time the user loosens his/her grip.

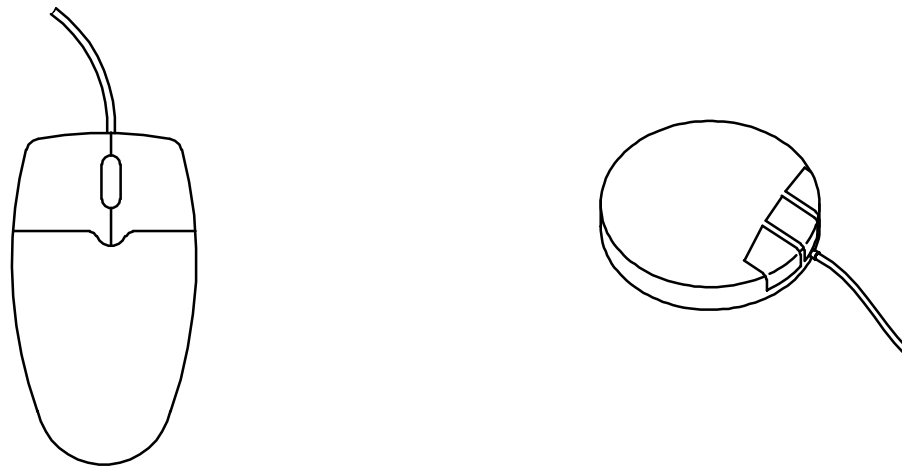

a) Appropriate mouse shape

b) Less appropriate mouse shape

Figure C.1 – Easily detectable orientation by means of shape

C.2.1.3 User compatibility of the mouse

The design of mice can accommodate the anthropometric characteristics of adult user populations to a degree that throughput and accuracy for pointing tasks are limited by the capabilities of the limbs involved (arm, hand and fingers) but not by the characteristics of the device. Thus, in general, mice are considered fully compatible (C1). If the design of a device restricts the effectiveness and/or efficiency of pointing, this shall be indicated.

NOTE 1 There is a clear indication that the mouse as a device does not restrict the capability of the hand/arm by its design characteristics *per se*. Thus, it can be considered fully compatible (in contrast to, e.g. the joystick).

No clear evidence could be found as to whether or not mice designed for adult users are also compatible with children or users with similarly small hands.

NOTE 2 Anecdotal evidence suggests that persons with either small or large hands feel more satisfied using an input device that fits their hand size.

For a neutral posture, the forearm, wrist and fingers are relevant. The neutral posture or most relaxed posture of the forearm is believed to be with the hands about 30° from vertical. Most mice require the pronating of the forearm by up to 60°, i.e. hands orientated horizontally. Some mice facilitate a less pronated posture (see Figure C.2).

The contracting force of the muscle is relevant for fingers used for actuating the buttons and a thumb involved in the movement of the device. It can be assumed that mouse design does not require more than 1 % of the maximum force of the involved muscles.

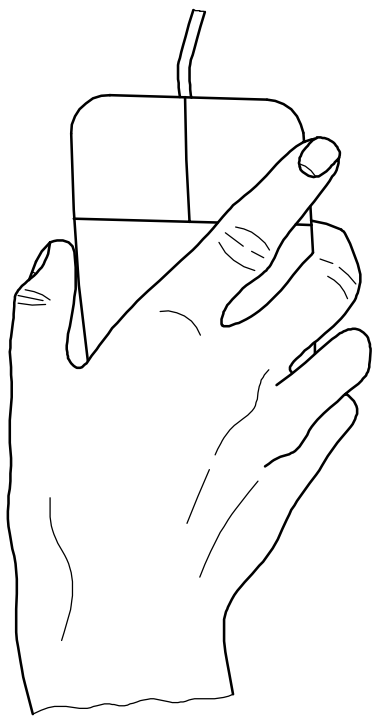

**a) Less-neutral posture –
Forearm pronated and wrist deviated**

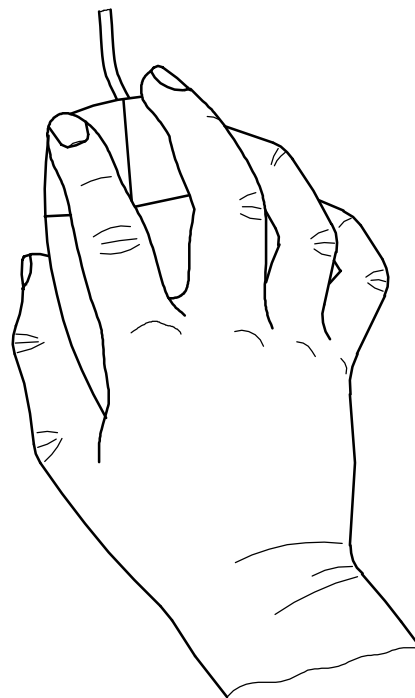

**b) Mouse whose use promotes
neutral position of forearm**

**Figure C.2 – Illustration of the tendency to pronation and deviation caused by
the orientation of the device and the button access**

C.2.1.4 Feedback

The mouse as a hand- and finger-operated device gives directly tactile feedback on its relative position to the user and, if properly designed, on its orientation in space as well. If connected to an appropriately functioning system, an optical signal will be generated to indicate the relative position on the screen.

The main feedback generated by the mouse is visual (movement of the pointer on the screen). This feedback will be consistent if not deliberately manipulated by the system (e.g. converted into tactile or auditive feedback).

The movement of the pointer on the screen needs to be displayed without undue delay. This is the case if, for the visual feedback, the feed forward signal from the input device to the system occurs within 20 ms.

NOTE Any delay in the hand/eye control loop is likely to cause loss of user performance. A delay of up to 20 ms does not degrade user performance because it is usually not perceived. A delay of 40 ms results in a 10 % reduction in user performance and a delay of 100 ms causes a 50 % reduction in user performance compared with a situation in which no perceptible delay occurs.

The feedback for the button activities will be generated at least partly by the system. If the buttons are designed to give kinaesthetic feedback, the minimum displacement should be 0,5 mm. The maximum displacement shall be 6 mm.

C.2.1.5 Controllability of the mouse

C.2.1.5.1 Reliability of device access

For reliability of device access, the design of the mouse shall enable the user to sense the orientation of the device without visual access to it (see C.2.1.2, predictability of the pointer's movement).

C.2.1.5.2 Adequacy of device access

Quick and easy access to a mouse (grasp, position, manipulate) is mainly determined by the characteristics of the support surface and by additional physical input devices to be used together with it. Operating a mouse requires a free, smooth, horizontal surface of about A4 paper size (portrait format), preferably within close reach of the user.

NOTE This part of ISO 9241 gives no specific requirements concerning design for adequacy of device access.

C.2.1.5.3 Control access

The design of the device shall ensure that actuating any button or combination of buttons shall not move the focus of the pointer.

The buttons should be located such that they minimize finger extension or other movement or positioning that could cause finger strain (see Figure C.3).

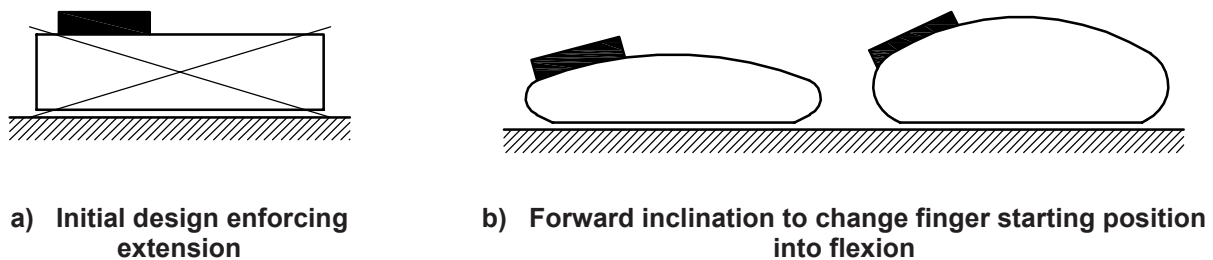

Figure C.3 – Orientation of the mouse button for minimising finger extension

C.2.2 Functional properties

C.2.2.1 Anchoring

Since the mouse is an input device designed to be used for fine-positioning accuracy, it shall be possible to anchor some part of the fingers, hand, wrist or arm on either the input device or the work surface in order to create a stable relationship between the hand and the point of action.

C.2.2.2 Resolution (task precision)

Input devices should be designed such that they achieve a resolution that supports the precision required by the task primitive. Since the most important task for a mouse is pointing, the resolution required will be determined by this task primitive.

The task precision required for a mouse can be categorized into the following classes:

C1 high (index of difficulty greater than 6);

C2 medium (index of difficulty greater than 4 and less than or equal to 6);

C3 low (index of difficulty greater than 3 and less than or equal to 4);

C4 very low (an index of difficulty less than or equal to 3).

A product can achieve the required levels of resolution either in an environment where other physical input devices are irrelevant for the operation or under consideration of an additional device. The method by which the level of task precision has been determined shall be indicated.

For a mouse with operating systems based on GUI (graphical user interface) and for general-purpose applications, the category shall be determined for the following keyboard utilization (see Figure B.2):

- full-size keyboard located with alphanumeric zone centred in front of the user;
- shoulder width for 5th percentile female of the intended user population;
- overall length of keyboard at least the length of a full-size keyboard (420 mm).

NOTE This position is not an optimum working position.

C.2.2.3 Sensor location

The motion sensing point (such as the rolling ball on the underside of a typical mouse) should be located under the fingers rather than under the palm of the hand.

NOTE "Finger" also applies to the thumb.

C.2.2.4 Button design

C.2.2.4.1 Button motion

The device should be so designed that during its intended use the fingers are able to make contact and actuate buttons without excessive deviation from a neutral posture.

NOTE "Excessive" means, for example, interfering with accuracy or causing muscular strain.

C.2.2.4.2 Button actuation

It should be possible to press the buttons on the mouse without reducing control of the device.

C.2.2.4.3 Button activation

The input device should be designed to be resistant to inadvertent button activation during its intended use.

C.2.2.4.4 Button shape

Buttons should be shaped to assist finger positioning and button actuation.

C.2.2.4.5 Button force

Buttons should have a displacement force within the range of 0,5 N to 1,5 N, until actuation.

Button force should be minimized without compromising usability.

C.2.2.4.6 Button displacement

Buttons intended for providing kinaesthetic feedback should have a minimum displacement of 0,5 mm. The maximum displacement shall be 6 mm.

C.2.2.4.7 Inadvertent pointer movement

The input device should be so designed that neither inadvertent button actuation nor intended button actuation causes unintended movement of the pointer.

C.2.2.4.8 Button lock

The input device shall be so designed that a hardware or software lock can be provided for buttons that need to be continuously depressed for the duration of a task primitive such as dragging, tracing or free-hand input.

C.2.2.5 Consideration of handedness

Input devices should be operable by the use of either hand; alternatively, right and left-handed devices should be available.

The shape and location of the controls (buttons, wheel) should be selected so as to support ambidextrous use of a device.

C.2.2.6 Resolution consistency

The resolution of a mouse shall be independent of both the position of the device on the work surface and the position of the pointer on the display.

Nevertheless, the resolution may be changed by the software or the user.

C.2.3 Mechanical properties

Guidance on mechanical properties is given in C.2.1 and C.2.2.

C.2.4 Electrical properties

For mice that do not require an external power supply, electrical properties are unrelated to usability.

The influence of cabling can be twofold: first, the cable requires a certain free space beyond the space the mouse requires to move; second, the cable can pull or turn the mouse if too heavy or too stiff.

The following three classes apply to cabling:

C1 no cable;

C2 cable that does not interfere with mouse use;

C3 cable that interferes with mouse use so that the user needs additional devices to prevent this interference.

Electromagnetic influences on other equipment at the same workstation may be considered irrelevant, owing to regulations for electromagnetic compatibility.

The weight of the mouse is only relevant for the friction between the support surface and the underside of the device. Additional batteries have only low, if any, impact on friction.

C.2.5 Maintainability-related properties

Maintainability-related properties of mice (excluding optical mice) to be considered for usability reasons are

- the surface of the ball (cleaning), and
- the ball housing.

NOTE Optical mice have no ball and thus need less maintenance.

Those parts of a mouse that need cleaning are the ball itself and/or the movement sensors (see Figure C.4). The design of the mouse shall enable the user to access these parts without the use of tools.

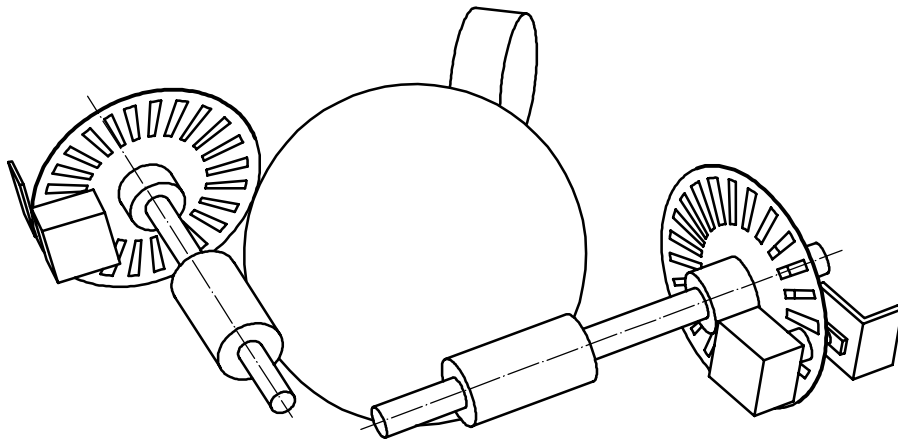

Figure C.4 – Mechanical parts of mouse that need cleaning – Ball and movement sensors

For a mouse with its own power supply, the following usability-related aspects need to be considered:

- dependence of operational characteristics from power supply (voltage and current) (battery-operated mice);
- durability of batteries;
- indicators for insufficient power supply (e.g. low voltage).

C.2.6 Health- and safety-related properties

SAFETY PRECAUTIONS – Mice should not contain, nor be made of, materials known to cause health and safety problems through skin contact or emissions.

There are no known user safety issues related to the mechanical design of mice, except for the avoidance of sharp edges and corners. Edges and corners on mice shall not cause discomfort or injury. This requirement is met if the minimum radius is 2 mm for edges and 3 mm for corners.

The weight of a mouse is in general so low that even hand-held devices can be used without the weight causing a problem for the user.

Mice with a cable can be pushed back through the tension in the cable if the weight is too low. In this case, users tend to keep the mouse firmly held in the hand, resulting in static muscle load. The avoidance of such an effect requires counter measures such as friction between the device and the support surface. If the operation of the device requires a specific area with certain properties (e.g. mouse pad, desk surface) the

friction necessary should be determined for that surface. If the mouse is designed to be used on any surface, the friction should be determined for the surface with the lowest coefficient of friction.

C.2.7 Interdependency with software

If dedicated software is not delivered together with a device, the documentation (see C.3) shall specify how the device is to be operated to achieve the intended level of effectiveness and efficiency.

The documentation shall specify the setup of the device. It should be possible to test the effects of the settings.

C.2.8 Interdependency with use environment

Potential remedies against vibration of the user and/or the support surface can be realized with adequate software. Since this part of ISO 9241 deals with physical devices only, it gives no such provisions.

The size and location of the available free space for moving the mouse not only affect the usability of the mouse but also the workload of the user. If the space is only limited by the reach of the user and not by the design of the support surface or other equipment used there, a constant-gain mouse is equivalent to a variable-gain device that changes the display/control ratio depending on the speed of the movement. For limited space, the variable-gain mouse offers some benefits. Thus, there is a clear interdependency between space characteristics, software properties and the usability of the device.

C.3 Documentation

The interdependency described above can be resolved by adequate user information. This shall include the following:

- optimum location of the mouse for best effectiveness, efficiency and postural comfort as the indicator of user satisfaction;
- best location of the device for concurrent use with a keyboard;
- adjustment of gain for limited space for the operation.

Surface characteristics of the support surface can affect effectiveness and efficiency.

If reaching the maximum level of effectiveness and efficiency for a given device requires certain characteristics, the relevant requirements shall be specified in the documentation.

Mice with mechanical balls suffer from characteristics of the support surface other than those affecting optical mice. In general, the operation of optical mice is more independent of the characteristics of the support surface.

Dust, sand or dirt can interfere with mouse operation. For usual work spaces or living areas, provisions for easy cleaning of the mouse are considered sufficient. For industrial areas or open spaces with a considerable amount of pollution, organizing the cleaning and testing of the characteristics affecting the device could be warranted.

Annex D (normative)

Pucks

D.1 Properties of the puck

D.1.1 General

Pucks are devices used in conjunction with an input tablet for precise positioning. Even if a puck resembles a mouse, the function is different. While a mouse uses relative positioning, the puck is tied to the absolute position on the tablet. For target acquisition, the puck needs at least a button or equivalent.

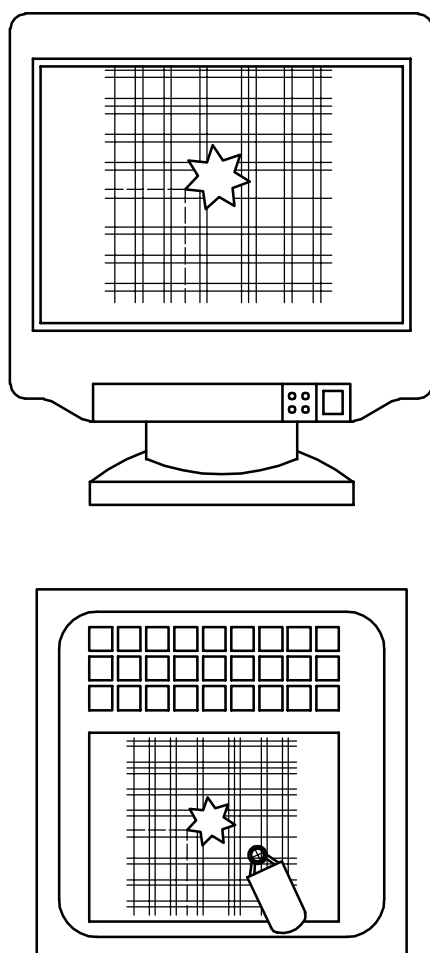

Figure D.1 – Fixed relation between puck position and pointer on-screen position

D.1.2 Functional properties

The functional properties of the puck are related to the following:

- anchoring the body parts needed for holding and controlling the device;
- positioning the reticle window correctly at the target;
- target acquisition.

The relevant properties for anchoring are the mechanical design of the housing and the buttons. For locating the target, the resolution of the tablet and the magnification of the image under the reticle window are important. For target acquisition, the location of the sensor, the dynamic properties of the button (motion, actuation and the interference of the actuation with the control of the device) are important.

D.1.3 Mechanical properties

Those mechanical properties of a puck relevant for usability are

- shape, profile (2 directions),
- size (length, width, height),
- buttons (position, shape, force, feedback), and
- size of reticle window.

D.1.4 Electrical properties

Those electrical properties of a puck relevant for usability are

- cabling,
- electromagnetic influences on the environment caused by the device, and
- batteries, if included.

D.1.5 Maintainability-related properties

Maintainability-related properties relevant for usability are those related to the cleaning of the device or parts of it and to the power supply for battery-operated pucks.

D.1.6 Health- and safety-related properties

The properties of pucks that need to be considered for the user's health and safety are

- electrical safety (devices with external power supply),
- chemical safety (e.g. fumigation), and
- mechanical safety (e.g. sharp edges).

D.1.7 Interdependency with software

The operation of a puck is highly software-dependent. Normally, the user is allowed to introduce some relevant changes into the software that can considerably change the usability of the device. The user can, for example, subdivide the sensitive tablet area into various parts with different characteristics and define an indefinite number of virtual buttons.

The puck is usually delivered with, and operated by means of, a specific tablet and software (the driver). Both can limit or enhance the puck's features.

D.1.8 Interdependency with use environment

The use of a puck is unlikely to influence the environment of the workplace except for the noise of clicking. In certain cases, signals on cables of other devices in the vicinity of the tablet can be influenced.

The use of a puck can be affected by the following environmental conditions:

- size and location of the sensitive tablet area;
- instability of the support surface;
- glare from reflections in the reticle window;
- parallax error if the tablet is positioned too far away from the user.

D.2 Design requirements

D.2.1 Correspondence with generic design requirements

D.2.1.1 Appropriateness of the puck

Since pucks are pointing devices designed for control by the eye, hand and lower arm, an appropriate general-purpose design is recommended to enable users to achieve the maximum accuracy for these limbs. Pucks can achieve a task precision corresponding to C1 (index of difficulty greater than 6, see D.2.2.2).

D.2.1.2 Operability of the puck

The obviousness of puck operation can be categorized into the following classes:

- C1 known or visible without the need for additional instructions and information;
- C2 detectable by the user by trial and error;
- C3 learnable by means of simple instructions;
- C4 learnable by means of special training.

C2 can be achieved for general-purpose devices and novice users.

NOTE A puck looks like a mouse, but functions somewhat differently. While mice detect change and speed of change, pucks sense position only and a knowledge of their function and vision through the reticle without parallax is needed. If a mouse is turned without moving it laterally, the pointer remains at its position; whereas, if the same action is made with a puck, the focus of the puck will remain somewhere else. Because of this, the operation of a puck is not as obvious as that of a mouse.

For C3 or C4 devices, the relevant information shall be included in the documentation. The predictability of the movement of the pointer on the screen in the cardinal directions can be assumed because all changes of the position of a puck are transmitted to the system. The target point of the puck is equivalent to the pointer on the screen.

Regarding consistency of operation (device operates and responds in the same manner) pucks do not need a categorization, since the device is always operated on a specific tablet. Inconsistencies (e.g. different responses on different parts of the tablet) can result from settings of the software. However, such inconsistencies are likely to be introduced deliberately to improve certain abilities of the application (see Figure D.2).

The main feedback generated by the puck is spatial (position of the device on the tablet) and visual (position of the pointer on the screen). This feedback will be consistent if not deliberately manipulated by the system (e.g. being converted into tactile or auditive feedback).

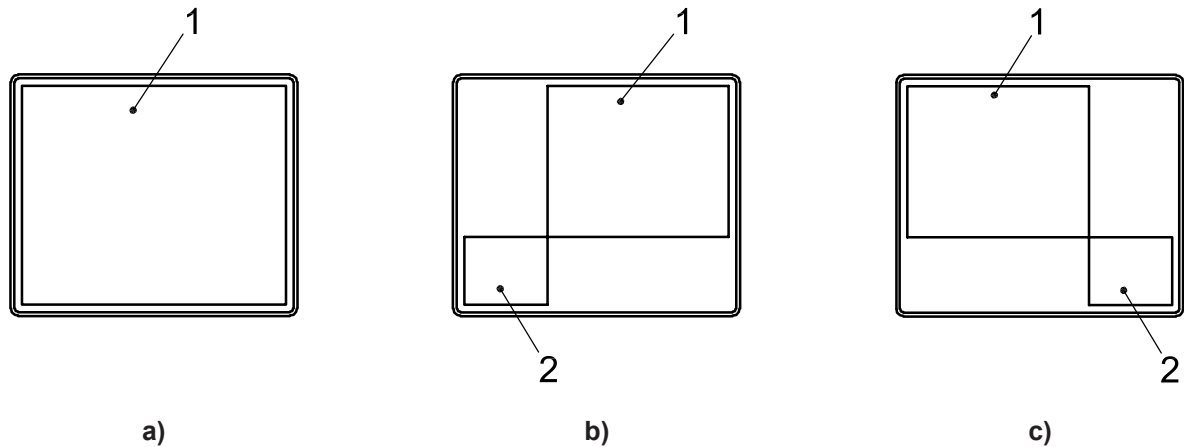

Area 1 in a), b) and c) corresponds to the entire space on the screen used for the application. To limit the movements of the arm and the hand required for a certain action, the sensitivity of the tablet may be changed so that either areas 1 or 2 in b) and c) correspond to the same screen area.

Figure D.2 – Different uses of sensitive area of tablet

D.2.1.3 User compatibility

The design of pucks can accommodate the anthropometric characteristics of adult user populations to a degree that accuracy for pointing tasks is limited by the capabilities of the limbs involved (arm, hand and fingers) but not by the characteristics of the device. Thus, in general, pucks are considered fully compatible (C1). If the design of a device restricts the effectiveness and/or efficiency of pointing, this shall be indicated.

The accuracy of operation of the same puck may be different on tablets of different size. The difference depends on the size of the device as well as on its position in relation to the user.

For the compatibility of the puck in consideration of the anthropometric dimensions of the intended user population, no conclusive knowledge exists. For the reasons given above, no requirements are provided in this part of ISO 9241. However, the design of a puck should consider neutral finger and wrist postures for different anthropometric percentiles, keep muscle forces low and minimize static work load. Although the design of most pucks resembles that of a mouse, the involvement of the hand and arm is different, and, in addition, visual control is important for operation.

No clear evidence could be found as to whether or not pucks designed for adult users are also compatible with children or users with similarly small hands.

NOTE Anecdotal evidence suggests that persons with small or large hands feel more satisfied using an input device that fits their hand size.

For the angle of joint, the underarm, wrist and fingers are relevant. Since the design of most pucks does not require a static deviation from the neutral position for the wrist, C1 (deviation less than 10 % of maximum) could be considered usual. However, studies show that an ulnar deviation of more than 15° is common. The reason for this is the utilization of the buttons that enforce this posture (see Figure C.2).

The use of a puck requires pronating the lower arm.

The contracting force of the muscle is relevant for the fingers used for actuating the buttons, as well as for the thumb involved in the movement of the device. It can be assumed that puck design does not require more than 1 % of the maximum force of the involved muscles.

D.2.1.4 Feedback

As a hand- and finger-operated device, the puck gives directly tactile feedback on its relative position to the user. It also gives visual feedback, because its position on the tablet corresponds to the position of the pointer on the screen. If connected to an appropriately functioning system, an optical signal will be generated to indicate the absolute position on the screen.

There is no need for the movement of the pointer on-screen to be displayed without undue delay because the visual control of the positioning depends on the image of the object on the tablet. The operation of a puck is less sensitive to the correct timing of the visual indication of the input.

The feedback for the button activities will be generated at least partly by the system. If the buttons are designed to give kinaesthetic feedback, the minimum displacement should be 0,5 mm. The maximum displacement shall be 6 mm.

D.2.1.5 Controllability of the puck

D.2.1.5.1 Reliability of device access

Unintended loss of control during intended use is unlikely, since the positioning of a puck does not require a single continuous action. The movement can even be interrupted many times for an indefinite period of time.

D.2.1.5.2 Adequacy of device access

Quick and easy access to a mouse (grasp, position, manipulate) is mainly determined by the characteristics of the support surface and by additional physical input devices to be used together with it. Operating a puck requires a tablet that is preferably within the close reach envelope of the user. Normally, the surface characteristics of the tablet correspond to the needs of the operation.

NOTE This part of ISO 9241 has no specific requirements concerning design of the device's access adequacy.

D.2.1.5.3 Control access

The design of the device shall ensure that actuating any button or combination of buttons shall not move the focus of the pointer. The buttons should be located to minimise finger extension (see Figure D.3).

D.2.2 Functional properties

D.2.2.1 Anchoring

Since the puck is an input device designed to be used for fine-positioning accuracy, it shall be possible to anchor some part of the fingers, hand, wrist, or arm on either the input device or the work surface in order to create a stable relationship between the hand and the point of action.

D.2.2.2 Resolution (task precision)

Input devices should be designed such that they achieve a resolution that supports the precision required by the task primitive. Since the most important task for a puck is pointing, the resolution required will be determined by this task primitive. In general, pucks are counted as being among those input devices that enable the highest input resolution.

The task precision required for a puck can be categorized into the following classes:

- C1 high (an index of difficulty greater than 6);
- C2 medium (an index of difficulty greater than 4 and less than or equal to 6);

C3 low (an index of difficulty greater than 3 and less than or equal to 4);

C4 very low (an index of difficulty less than or equal to 3).

A product can achieve the required levels of resolution either in an environment where other physical input devices are irrelevant for the operation or where there is an additional device to be considered. In contrast to mice, pucks are often used for tasks where working with the pointing device can dominate the entire task. Thus, it may be assumed that the puck will take the optimum position.

For a puck with operating systems based on GUI (graphical user interface) and used for general-purpose applications, the category shall be determined for the following keyboard utilization (see Figure B.2):

- full-size keyboard located with alphanumeric zone centred in front of the user;
- shoulder width for 5th percentile female of the intended user population;
- overall length of keyboard at least the length of a full-size keyboard (420 mm).

The method by which the level of task precision has been determined shall be indicated.

NOTE This position is not an optimum working position.

D.2.2.3 Button design

D.2.2.3.1 Button motion

The device should be so designed that during its intended use the fingers are able to make contact and actuate buttons without excessive deviation from a neutral posture.

NOTE "Excessive" means, for example, interfering with accuracy or causing muscular strain.

Button contact surfaces should be perpendicular to the displacement direction of the button and to the motion of the finger during flexion.

D.2.2.3.2 Button actuation

It should be possible to press the buttons on a puck without unintentionally moving the device.

D.2.2.3.3 Button activation

The input device should be designed to be resistant to inadvertent button activation during its intended use.

D.2.2.3.4 Button shape

Buttons should be so shaped as to assist finger positioning and button actuation.

D.2.2.3.5 Button force

Buttons should have a displacement force within the range of 0,5 N to 1,5 N until actuation.

NOTE Button force should be minimized without compromising usability.

D.2.2.3.6 Button displacement

Buttons intended for providing kinaesthetic feedback should have a minimum displacement of 0,5 mm. The maximum displacement shall be 6 mm.

D.2.2.3.7 Inadvertent pointer movement

The input device should be so designed that inadvertent button actuation does not cause unintended movement of the pointer.

D.2.2.3.8 Button lock

The input device shall be so designed that a hardware or software lock can be provided for buttons that need to be continuously depressed for the duration of a task primitive such as dragging, tracing or free-hand input.

D.2.2.4 Consideration of handedness

Input devices should be operable by the use of either hand; alternatively, right and left-handed devices should be available.

The shape and location of the controls (buttons, wheel) should be selected so as to support ambidextrous use of the device.

D.2.2.5 Resolution consistency

The resolution of a puck shall be independent of both the position of the device and the tablet.

Nevertheless, the resolution may be changed by the software or the user. It can also be useful to create different settings for different parts of a tablet.

D.2.3 Mechanical properties

D.2.3.1 Unintended slippage

The puck should be resistant to unintended slippage if used on an inclined surface.

D.2.3.2 Reticle location

The reticle window should be designed and located on the puck so as to allow its operation without the user's head being excessively deviated (flexion) by more than 15°.

D.2.3.3 Reticle window

The reticle window should be sufficiently transparent and free of aberrations to allow appropriate legibility.

D.2.4 Electrical properties

For pucks that do not require an external power supply, electrical properties are unrelated to usability.

The influence of cabling can be twofold: first, the cable requires a certain free space beyond the space the puck requires to move; second, the cable can pull or turn the device when too heavy or stiff.

Electromagnetic influences on other equipment at the same workstation may be considered irrelevant, owing to regulations for electromagnetic compatibility.

The weight of the puck is only relevant for the friction between the support surface and the underside of the device. It is not affected by additional batteries.

D.2.5 Maintainability-related properties

Maintainability-related properties of pucks to be considered for usability reasons are

- the surface reticle window (cleaning), and
- the power supply for batteries.

The reticle window should be so formed as to facilitate cleaning. If cleaning requires certain precautionary measures, this shall be indicated in the documentation.

The durability of the batteries, if included, and their electrical characteristics shall be such that they ensure the user can complete the last action after being warned without high time pressure. The puck should function properly for at least 1 min after the indication of the battery status.

D.2.6 Health- and safety-related properties

SAFETY PRECAUTIONS – Pucks should not contain, nor be made of, materials known to cause health and safety problems through skin contact or emissions.

Edges and corners on pucks shall not cause discomfort or injury. This requirement is met if the minimum radius is 2 mm for edges and 3 mm for corners.

D.2.7 Interdependency with software

If dedicated software is not delivered together with a device, the documentation (see D.3) shall specify how the device is to be operated to achieve the intended level of effectiveness and efficiency.

The documentation shall specify the setup of the device. It should be possible to test the effects of the settings.

D.2.8 Interdependency with use environment

Potential remedies against vibrations of the user and/or the support surface can be realized with adequate software. Since this part of ISO 9241 deals with physical devices only, it gives no such provisions.

D.3 Documentation

The user information shall include the following:

- optimum location of the tablet and puck for best effectiveness, efficiency and postural comfort as the indicator of user satisfaction;
- best location of the device for concurrent use with a keyboard;
- features of the hardware/software that could improve postural comfort or reduce biomechanical load (e.g. subdivision of the tablet in smaller areas with different resolution).

Surface characteristics of the support surface can affect effectiveness and efficiency. If reaching the maximum level of effectiveness and efficiency for a given device requires certain characteristics, the relevant requirements shall be specified in the documentation.

Dust, sand or dirt can interfere with puck operation. For usual work spaces or living areas, no provisions are necessary. For industrial areas or open spaces with a considerable amount of pollution, organizing the cleaning and testing of the characteristics affecting the device could be warranted.

Annex E (normative)

Joysticks

E.1 Properties of joysticks

E.1.1 General

Joysticks are devices for input in three dimensions. They can comprise a number of controls such as buttons, sliders and switches, and can also be used as haptic displays — and thus as a haptic interface. Common to all devices of this kind is a mechanical lever (stick) of a size ranging from some millimetres (portable computers) to arm length (heavy-duty vehicles). The lever and the housing of the device can contain an unlimited number of controls of different functionality.

Joysticks belong to that group of the most versatile design elements. They can be utilized for highly sophisticated tasks such as aircraft or missile control by trained personnel, as well as by severely handicapped users who cannot move more than few muscles in and around their mouth (e.g. tongue-operated joysticks) (see Figure E.1).

The great variety of different technical designs and applications for joysticks places limits on the standardization of all their common relevant features.

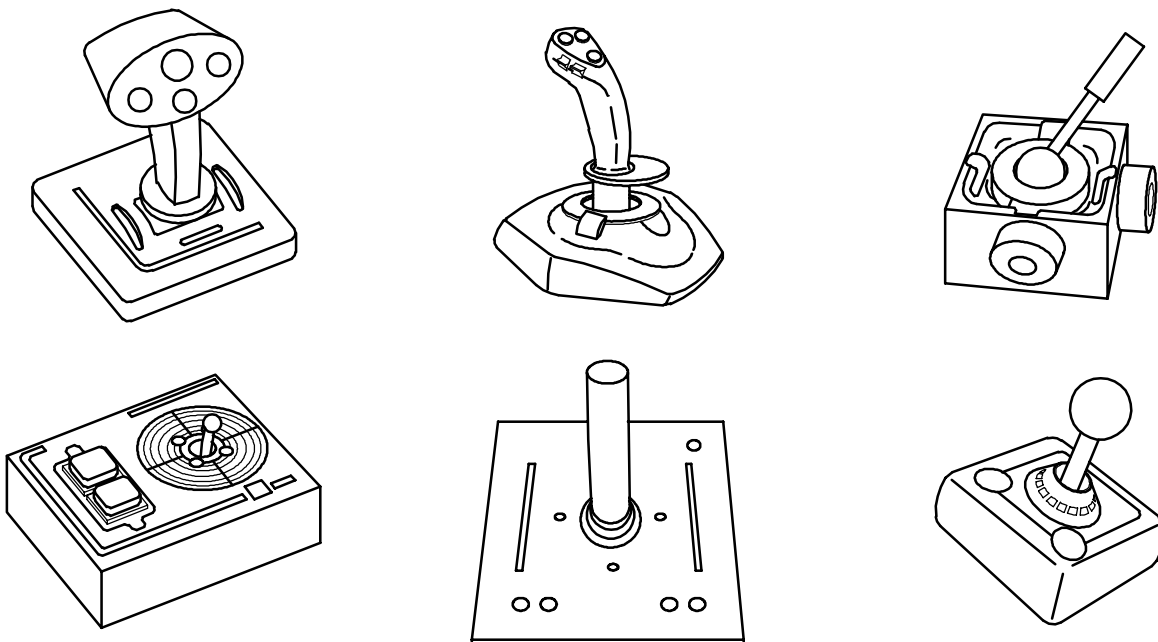

Figure E.1 – Different joystick designs

E.1.2 Functional properties

The functional properties of joysticks are related to the following:

- anchoring of the body parts needed for holding and controlling the device (hand, fingers and thumb);
- anchoring of the device on the work surface or on other objects;
- target acquisition;
- additional input through buttons, sliders, switches, etc.

The relevant properties for anchoring are the mechanical design of the lever, the housing and the buttons.

For target acquisition, the characteristics of the lever, location of the sensors, dynamic properties of the buttons — motion, actuation and interference of actuation by the control of the device — are important.

E.1.3 Mechanical properties

Those mechanical properties of a joystick relevant for usability are

- form of the lever,
- form and location of the buttons, and
- form, location and visibility of other controls.

E.1.4 Electrical properties

Those electrical properties of a joystick relevant for usability are

- cabling,
- electromagnetic influences on the environment caused by the device, and
- batteries, if included.

E.1.5 Maintainability-related properties

Maintainability-related properties relevant for usability are related to the cleaning of the device or parts of it and to the power supply for battery-operated joysticks.

E.1.6 Health- and safety-related properties

Health- and safety-related properties are related to the material selection.

E.1.7 Interdependency with software

The operation of a joystick is highly software-dependent. Normally, the user is allowed to introduce many relevant changes in the software and mechanical controls that can considerably change the usability of the device.

A joystick is usually delivered with, and operated by means of, software (the driver). Unlike all other drivers that allow the settings to be changed, joystick drivers are also controlled by mechanical buttons, sliders, etc, all of which can limit or enhance the features of the device.

E.1.8 Interdependency with use environment

The use of a joystick is unlikely to influence the environment of the workplace except for the noise of clicking.

The use of a joystick is, in most cases, not severely affected by environmental conditions such as vibration or accelerations, which is one reason why these devices are used in aircraft, vehicles, ships or other machinery.

E.2 Design requirements

E.2.1 Correspondence with generic design requirements

E.2.1.1 Appropriateness of joysticks

Since joysticks are pointing devices designed to be controlled by the hand, lower arm and fingers, an appropriate general-purpose design is recommended to enable users to achieve the maximum speed and accuracy for these limbs.

For the compatibility of joysticks in consideration of the anthropometric dimensions of the intended user population, no conclusive knowledge exists from which generalizations can be made. For this reason, no related requirements are given in this part of ISO 9241. However, the design of a joystick should take into consideration neutral finger and wrist postures for different anthropometric percentiles, while keeping muscle forces low and minimizing static work load.

NOTE The joystick was one of the very first input devices to be subject to ergonomic research and evaluation (it has been in use in military aviation, for instance, since the First World War). Many current designs used for games resemble devices developed many decades ago. The question is whether these follow the same design guidelines because of those designs' proven validity or merely as a result of convention.

E.2.1.2 Operability of joysticks

The obviousness of joystick operation can be categorized into the following classes:

- C1 known or visible without need for additional instructions and information;
- C2 detectable by the user by trial and error;
- C3 learnable by means of simple instructions;
- C4 learnable by means of special training.

C2 or C3 can be achieved in the cases of general-purpose devices and novice users. Only very simple devices with a lever movable in the cardinal directions are considered as being C1. For C3 and C4 devices, the relevant information shall be included in the documentation.

The predictability of the pointer's movement on the screen in the cardinal directions can be assumed if the device operates in two dimensions. Because of various manipulations of the apparent movement of the pointer by more complex operations (e.g. 3D applications with acceleration in parts of the space), no precise advice can be given.

Regarding consistency of operation (device operates and responds in the same manner), joysticks are among the best products available because of their high degree of independence from the environment. Joysticks can be operated consistently even in unusual body postures.

The feedback provided from one joystick to another can be very different. For example, while isometric joysticks give (passive) force feedback only, other types also provide kinaesthetic feedback, and where the isometric joystick's feedback is passive — meaning that the application does not manipulate it (users feel the

pressure against the lever that they themselves exert) — “force feedback” joysticks can provide different types of feedback and display information that reaches far beyond a simple response.

E.2.1.3 User compatibility of joysticks

The evaluation of the user compatibility of joysticks in general is extremely difficult since the size can reach from some millimetres (small button integrated into a keyboard, to be operated by fingertip) to heavy-duty power grip handles. Controls requiring all possible types of grip, to be activated under more than one circumstance at the same time, can be built into a device (see Figure E.2).

Evaluating such a complex device for user compatibility within the context of this part of ISO 9241 has not been considered possible on the basis of conventional knowledge of human factors — especially since almost all the muscles of an upper limb and all those other muscles related to their operation are involved.

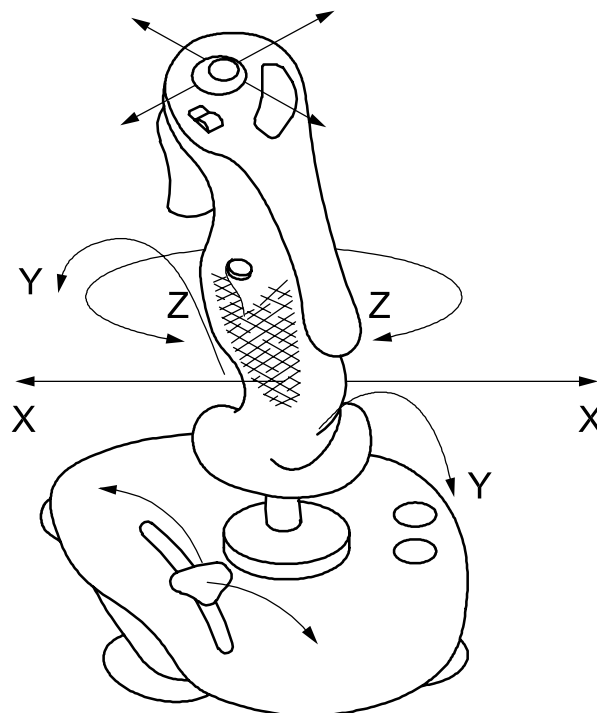

Figure E.2 – Joystick design with three degrees of freedom for lever and two for control (top) and with various additional controls

Such complex mechanisms can be evaluated using the outcome of user actions, e.g. by throughput (performance) and/or errors (accuracy).

Recent research suggests that the joystick is inferior to some other, more customary, input devices (touchpad, trackball and mouse) in terms of performance and accuracy (see Bibliographic reference [15]). This is an indication for a lower compatibility with user characteristics.

It must be noted, however, that there is no device comparable to joysticks in terms of functionality.

There is little conclusive advice in the literature regarding the user compatibility of the form of the joystick or similar devices using levers. However, the recommendation not to design parts that are to be grasped by the hand, “anthropomorph”, is justified because of the anthropometric differences of the human hand. The recommendation is based on the rationale that good compatibility with the hand can be achieved for a small number of users but that there will be problems for the rest of the user population. For this reason, a simple ellipsoid shape for the lever is recommended.

E.2.1.4 Feedback

Depending on its functionality, a joystick can provide different types of feedback:

- force (passive), in the case of isometric and other joysticks;
- force (active), in the case of appropriately designed devices;
- haptic in general (force, vibration, torque, acceleration, etc.);
- visual (position of the lever, sliders, buttons, etc.);
- kinaesthetic (through buttons and other controls).

In complex devices, one or more of these varieties of feedback can occur simultaneously or in close sequential order.

NOTE Because of the complexity of the question, this part of ISO 9241 does not pretend to offer what would be of necessity only partial advice on individual elements of the device.

E.2.1.5 Controllability of joysticks

E.2.1.5.1 Reliability of device access

Unintended loss of control of the lever during intended use is unlikely, since it is usually designed for a tight grip (see Figure E.1).

E.2.1.5.2 Adequacy of device access

Quick and easy access to a joystick (lever) is given if the device is located within the reach envelope of the user.

E.2.1.5.3 Control access

The design of the device shall ensure that the actuating of any button or combination of buttons shall not move the focus of the pointer.

The buttons should be located so as to minimize extension of the digits.

E.2.2 Functional properties

E.2.2.1 Anchoring

Since joysticks are input devices designed to be used for fine-positioning accuracy, it shall be possible to anchor some part of the fingers, hand, wrist or arm on either the input device or the work surface in order to create a stable relationship between the hand and the point of action.

E.2.2.2 Resolution (task precision)

Input devices should be designed such that they achieve a resolution that supports the precision required by the task primitive. Since the most important task of a joystick is pointing, the resolution required will be determined by this task primitive. In general, joysticks cannot be counted among those input devices that enable the highest input resolution.

The task precision required for a joystick can be categorized into the following classes:

- C1 high (an index of difficulty greater than 6);
- C2 medium (an index of difficulty greater than 4 and less than or equal to 6);
- C3 low (an index of difficulty greater than 3 and less than or equal to 4);
- C4 very low (an index of difficulty less than or equal to 3).

For a joystick with operating systems based on GUI (graphical user interface) and for general-purpose applications, the category shall be determined for the following keyboard utilization (see Figure B.2):

- full-size keyboard located with alphanumeric zone centred in front of the user;
- shoulder width for 5th percentile female of the intended user population;
- overall length of keyboard at least the length of a full-size desktop keyboard (420 mm).

The method by which the level of task precision has been determined shall be indicated.

NOTE This position is not an optimum working position.

E.2.2.3 Button design

E.2.2.3.1 Button motion

The device should be so designed that during its intended use the fingers are able to make contact and actuate buttons without excessive deviation from a neutral posture.

NOTE "Excessive" means, for example, interfering with accuracy or causing muscular strain.

Button contact surfaces should be perpendicular to the displacement direction of the button and to the motion of the finger during flexion.

E.2.2.3.2 Button actuation

It should be possible to press the buttons on a joystick without unintentionally moving the device.

E.2.2.3.3 Button activation

The input device should be designed to be resistant to inadvertent button activation during its intended use.

E.2.2.3.4 Button shape

Buttons should be so shaped as to assist finger positioning and button actuation.

E.2.2.3.5 Button force

Buttons should have a displacement force within the range of 0,5 N to 1,5 N, until actuation.

Button force should be minimized without compromising usability.

E.2.2.3.6 Button displacement

Buttons intended for providing kinaesthetic feedback should have a minimum displacement of 0,5 mm. The maximum displacement shall be 6 mm.

E.2.2.3.7 Inadvertent pointer movement

The input device should be so designed that inadvertent button actuation does not cause unintended movement of the pointer.

E.2.2.3.8 Button lock

The input device shall be so designed that a hardware or software lock can be provided for buttons that need to be continuously depressed for the duration of a task primitive such as dragging, tracing or free-hand input.

E.2.2.4 Consideration of handedness

Input devices should be operable by the use of either hand; alternatively, right and left-handed devices should be available.

The shape and location of the controls should be selected so as to support ambidextrous use of the device.

E.2.2.5 Resolution consistency

The resolution of the joystick shall be independent of the position of the lever, if not deliberately designed to achieve a higher degree of usability.

Nevertheless, the resolution may be changed by the software or the user. Under some circumstances it can also be useful to create different resolutions for different parts of a target.

E.2.3 Mechanical properties

E.2.3.1 Unintended slippage

The base of the device shall not be able to be moved unintentionally during intended use.

E.2.3.2 Actuation force

The force needed to displace a finger-operated joystick should be between 0,05 N and 1,1 N.

E.2.3.3 Displacement

For hand-operated displacement joysticks, the displacement should not exceed 45° to the left or right, 30° in the forward direction (away from the user) or 15° in the backward direction (towards the user).

E.2.3.4 Button location

The function buttons of a finger-operated joystick should be located on top of the handle so that they can be actuated by the index finger.

The function buttons of a hand-operated joystick should be located on the top or side so that they can be actuated by the thumb, index or middle digit.

E.2.4 Electrical properties

For joysticks that do not require an external power supply, electrical properties are unrelated to usability.

The influence of cabling on the operation of a joystick does *not* affect the usability of the device.

Electromagnetic influences on other equipment at the same workstation may be considered irrelevant, owing to regulations for electromagnetic compatibility.

The weight of the joystick is not relevant for its operation, except in the case of handheld devices.

E.2.5 Maintainability-related properties

There are no known usability issues in respect of the maintainability-related properties of joysticks.

E.2.6 Health- and safety-related properties

SAFETY PRECAUTIONS – Joysticks should not contain, nor be made of, materials known to cause health and safety problems through skin contact or emissions.

Those parts of a joystick that are grasped during use should have low thermal conductance.

Edges and corners on joysticks shall not cause discomfort or injury. This requirement is met if the minimum radius is 2 mm for edges and 3 mm for corners.

E.2.7 Interdependency with software

If dedicated software is not delivered together with the device, the documentation (see E.3) shall specify how the device is to be operated to achieve the intended level of effectiveness and efficiency.

The documentation shall specify the setup of the device. It should be possible to test the effects of the settings.

E.2.8 Interdependency with use environment

Since the operation of this device is highly independent from the use environment, no such provisions are given in this part of ISO 9241.

E.3 Documentation

The user information shall include the following:

- optimum location of the device for best effectiveness, efficiency and postural comfort;
- best location of the device for concurrent use with a keyboard;
- features of the hardware/software that could improve postural comfort or reduce biomechanical load (e.g. setup for different buttons or changes in the setup aimed at relieving fingers and thumb).

Annex F (normative)

Trackballs

F.1 Properties of trackballs

F.1.1 General

Trackballs are devices for input in two dimensions. Although a third dimension can also be accessed, this cannot be done at the same time as the other two. The sensing mechanism of a trackball is almost identical with that of a mouse. The main difference is the mouse requires a *translatory* movement of the hand that is then translated into a rotatory movement of the ball, while on the trackball the ball itself is given a rotatory movement by the hand.

NOTE Trackballs belong to the oldest designs of input devices, utilized long before computers with graphical interfaces became popular. There are some designs today that integrate a trackball into a mouse.

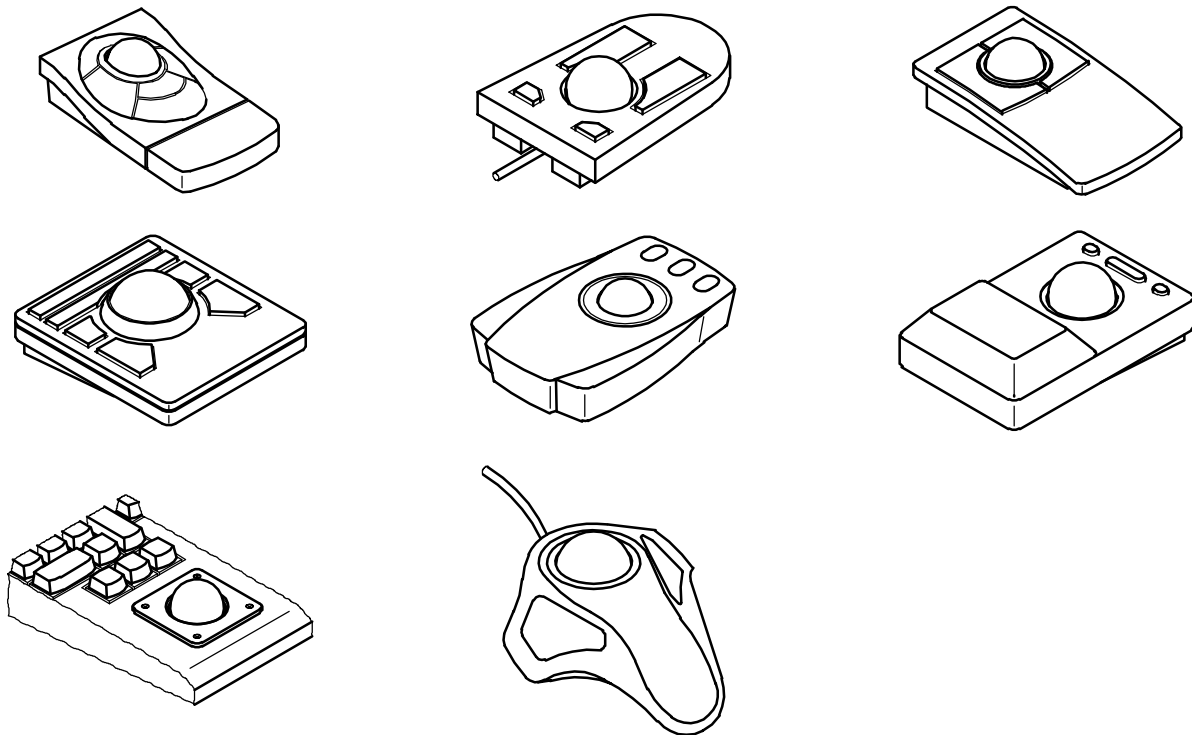

Figure F.1 – Various trackball designs

F.1.2 Functional properties

The functional properties of trackballs are related to the following:

- anchoring the body parts needed for holding and controlling the device (hand, fingers and thumb);

- anchoring the device on the work surface or on other objects;
- target acquisition;
- additional input through buttons, switches, etc.

The relevant properties for anchoring are the mechanical design of the housing, the ball and the buttons.

For target acquisition, the characteristics of the ball, location of sensors and dynamic properties of the buttons (motion, actuation and interference of actuation with the control of the device) are important.

F.1.3 Mechanical properties

Those mechanical properties of a trackball relevant for usability are

- shape, profile of the housing,
- exposed area of the ball (length, exposed arc),
- buttons (position, shape, force, feedback), and
- form, location and visibility of other controls.

F.1.4 Electrical properties

Those electrical properties of trackballs relevant for usability are

- cabling and
- batteries, if included.

F.1.5 Maintainability-related properties

Maintainability properties relevant for usability are related to cleaning the device (ball).

F.1.6 Health- and safety-related properties

SAFETY PRECAUTIONS – Trackballs should not contain, or be made of, materials known to cause health and safety problems through skin contact or emissions.

There are no known user health and safety issues related to the mechanical design of trackballs.

F.1.7 Interdependency with software

The operation of a trackball is highly software-dependent. Normally, the user is allowed to introduce some relevant changes in the software that can considerably change the usability of the device. The most important change users can make is adjusting gain to suit his or her personal preferences.

A trackball is usually delivered with, and operated by means of, either own-software that supports its entire functionality, or else it is operated with the aid of a “generic” driver that might possibly provide it with only limited capabilities.

Specific software can help to overcome limited abilities of the user.

EXAMPLE The electronic equivalent of a mechanical ruler enables even people with very limited drawing ability to draw straight lines more precisely than skilled draughtsman and highly independent of the environment (e.g. in shaky vehicles).

F.1.8 Interdependency with use environment

The use of a trackball is unlikely to influence the environment of the workplace except for the noise of clicking. Its use requires much less space than that of a mouse.

The use of a trackball can be affected by the following environmental conditions:

- vibration;
- instability of the support surface;
- dust and dirt, beverages.

In addition, sebum from the user's fingers and hand, as well as dirty or wet fingers, can affect the use of a trackball in a similar way to dirt from the environment.

F.2 Design requirements

F.2.1 Correspondence with generic design requirements

F.2.1.1 Appropriateness of trackballs

Since trackballs are pointing devices designed to be controlled by the hand and the fingers, an appropriate general-purpose design is recommended to enable users to achieve the maximum speed and accuracy for these limbs. However, most studies comparing different input devices show that the mouse is superior to the trackball in effectiveness and efficiency if evaluated in isolation. Nevertheless, trackballs can prove to be more appropriate if used together with a full-size keyboard for most applications with a graphical user interface or in any environment with limited space.

F.2.1.2 Operability of trackballs

The obviousness of trackball operation can be categorized into the following classes:

- C1 known or visible without the need for additional instructions and information;
- C2 detectable by the user by trial and error;
- C3 learnable by means of simple instructions;
- C4 learnable by means of special training.

C2 or C3 can be achieved in the cases of general-purpose devices and novice users. For C3 and C4 devices, the relevant information shall be included in the documentation.

The predictability of the pointer's movement on the screen in the cardinal directions can be assumed if the device operates in two dimensions. Because of various manipulations of the apparent movement of the pointer during more complex operations (e.g. 3D applications with acceleration in parts of the space), no precise advice can be given.

Regarding consistency of operation (device operates and responds in the same manner), trackballs are not the best product available because of their lack of independence from the environment (vibrations, accelerations).

The feedback provided from one trackball to another can be very different. While all trackballs provide kinaesthetic feedback, some are designed additionally to give force feedback. Trackballs can be designed as haptic displays.

F.2.1.3 User compatibility of trackballs

The design of a trackball can accommodate the anthropometric characteristics of adult user populations only to an extent where throughput and accuracy for pointing tasks are limited by the characteristics of the device. Thus, in general, trackballs cannot be considered as being fully compatible (C2).

Recent research suggests that the trackball is inferior to some other customary input devices (mouse and touchpad) in terms of performance and accuracy^[15]. This is an indication of lower compatibility with user characteristics.

F.2.1.4 Feedback

Depending on its functionality, a trackball can provide different types of feedback:

- force (active) by appropriately designed devices;
- haptic in general (force, vibration, acceleration etc.);
- kinaesthetic (through buttons and other controls).

In complex devices (e.g. trackball integrated into a mouse with different buttons), one or more of these varieties of feedback could occur simultaneously or in close sequential order. Because of the complexity of the question, this part of ISO 9241 will not give any partial advice for single elements of the device.

NOTE Because of the complexity of the question, this part of ISO 9241 does not pretend to offer what would be of necessity only partial advice on individual elements of the device.

F.2.1.5 Controllability of trackballs

F.2.1.5.1 Reliability of device access

Unintended loss of control of the ball can occur under unfavourable conditions and could occur more often than during use of a mouse or touchpad under the same conditions.

F.2.1.5.2 Adequacy of device access

Quick and easy access to a trackball is given if the device is located within the reach envelope of the user.

F.2.1.5.3 Control access

The design of the device shall ensure that actuating any button or combination of buttons shall not move the focus of the pointer.

The buttons should be located so as to minimize finger extension.

F.2.2 Functional properties

F.2.2.1 Anchoring

As trackballs are input devices designed to be used for fine-positioning accuracy, it shall be possible to anchor some part of the fingers, hand, wrist or arm on either the input device or the work surface in order to create a stable relationship between the hand and the point of action.

F.2.2.2 Resolution (task precision)

Input devices should be designed such that they achieve a resolution that supports the precision required by the task primitive. Since the most important task for a trackball is pointing, this task primitive will determine the resolution required. In general, trackballs cannot be counted among those input devices that enable the highest input resolution.

The task precision required for a trackball can be categorized into the following classes:

- C1 high (an index of difficulty greater than 6);
- C2 medium (an index of difficulty greater than 4 and less than or equal to 6);
- C3 low (an index of difficulty greater than 3 and less than or equal to 4);
- C4 very low (an index of difficulty less than or equal to 3).

For a trackball with operating systems based on GUI (graphical user interface) and for general-purpose applications, the category shall be determined for the following keyboard utilization (see Figure B.2):

- full-size keyboard located with alphanumeric zone centred in front of the user;
- shoulder width for 5th percentile female of the intended user population;
- overall length of keyboard at least the length of a full-size desktop keyboard (420 mm).

NOTE This position is not an optimum working position.

If the device is part of a more complex unit (e.g. portable computer), the category shall be determined for the typical use of that device.

The method by which the level of task precision has been determined shall be indicated.

F.2.2.3 Button design

F.2.2.3.1 Button motion

The device should be designed so that during its intended use the fingers are able to make contact and actuate buttons without excessive deviation from a neutral posture.

NOTE "Excessive" means, for example, interfering with accuracy or causing muscular strain.

Button contact surfaces should be perpendicular to the displacement direction of the button and to the motion of the finger during flexion.

F.2.2.3.2 Button actuation

It should be possible to press the buttons of a trackball without unintentionally moving the device.

F.2.2.3.3 Button activation

The input device should be designed so as to be resistant to inadvertent button activation during its intended use.

F.2.2.3.4 Button shape

Buttons should be shaped so as to assist finger positioning and button actuation.

F.2.2.3.5 Button force

Buttons should have a displacement force within the range of 0,5 N to 1,5 N, until actuation.

Button force should be minimized without compromising usability.

F.2.2.3.6 Button displacement

Buttons intended for providing kinaesthetic feedback should have a minimum displacement of 0,5 mm. The maximum displacement shall be 6 mm.

F.2.2.3.7 Inadvertent pointer movement

The input device should be designed so that inadvertent button actuation does not cause unintended movement of the pointer.

F.2.2.3.8 Button lock

The input device shall be designed so that a hardware or software lock can be provided for buttons that need to be continuously depressed for the duration of a task primitive such as dragging, tracing or free-hand input.

F.2.2.4 Consideration of handedness

Trackballs should be operable by the use of either hand; alternatively, right and left-handed devices should be available.

The shape and location of the controls should be selected so as to support ambidextrous use of the device.

F.2.2.5 Resolution consistency

The resolution of a trackball shall be independent of the position of the ball.

Nevertheless, the resolution may be changed by the software or the user. Under some circumstances it can also be useful to create different resolutions for different parts of a target.

F.2.3 Mechanical properties

F.2.3.1 Size

The chord length of the exposed area of the trackball should be at least 25 mm. The exposed arc, measured from the centre of the trackball, should be not less than 100° and not greater than 140° (see Figure F.2). The recommended exposed arc is 120°.

Dimensions in millimetres

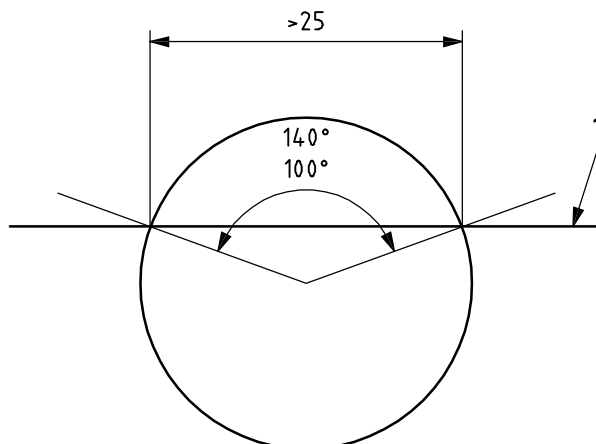

Key

1 input device surface

Figure F.2 – Chord length and exposed arc of trackball

F.2.3.2 Unintended slippage

The base of the device shall not be able to be moved unintentionally during intended use.

F.2.3.3 Actuation (rolling) force

The rolling force of a trackball should be between 0,2 N and 1,5 N. The starting resistance should be from 0,2 N to 0,4 N.

F.2.3.4 Displacement

A trackball is not a displacement device.

F.2.3.5 Button location

The buttons shall be located such that their use does not interfere with the operation of the ball.

The shape and location of the controls (buttons, wheel) should be selected so as to support ambidextrous use of the device.

F.2.4 Electrical properties

For trackballs that do not require an external power supply, electrical properties are unrelated to usability.

The influence of cabling on the operation of a trackball does not affect the usability of the device. Electromagnetic influences on other equipment at the same workstation may be considered irrelevant, owing to regulations for electromagnetic compatibility.

The weight of the trackball is not relevant for its operation, except in the case of handheld devices.

F.2.5 Maintainability-related properties

The ball shall be easily removable for cleaning.

For environments where dust or spill could affect the operation of the device, trackballs with rugged design features (e.g. sealed, spill-proof, dust-proof, beverage immune) can be utilized.

F.2.6 Health- and safety-related properties

SAFETY PRECAUTIONS – Trackballs should not contain, or be made of, materials known to cause health and safety problems through skin contact or emissions.

Edges and corners on the housing of trackballs shall not cause discomfort or injury. This requirement is met if the minimum radius is 2 mm for edges and 3 mm for corners.

F.2.7 Interdependency with software

If dedicated software is not delivered together with the device, the documentation (see F.3) shall specify the manner in which the device is to be operated to achieve the intended level of effectiveness and efficiency.

The documentation shall specify the setup of the device. It should be possible to test the effects of the settings.

F.2.8 Interdependency with use environment

The influence of vibration can be reduced by an adequate design of those parts that can be used to anchor parts of the hand or fingers during actuation.

Potential remedies against vibration of the user and/or the support surface can be realized with adequate software. Since this part of ISO 9241 deals with physical devices only, it gives no such provisions.

F.3 Documentation

The user information shall include the following:

- optimum location of the device for best effectiveness, efficiency and postural comfort;
- best location of the device for concurrent use with a keyboard;
- features of the hardware/software that can improve postural comfort or reduce biomechanical load (e.g. setup for different buttons or changes in the setup to relieve fingers and thumb).

Annex G (normative)

Touchpads

G.1 Properties of touchpads

G.1.1 General

Touchpads function similarly to tablets, without, however, the tablet's need for a mechanical intermediary (such as a stylus or puck) between the hand and the sensing mechanism — hence the synonym, *touch-sensitive* tablet.

Like all tablets, touchpads allow input in two dimensions; unlike mice or joysticks, touchpads can be made to sense multiple points of contact.

Touchpads are designed in a variety of sizes, but most are small (several square centimetres) and built into portable devices. They can be moulded into one-piece constructions, thus eliminating grooves where dirt can collect. This makes them well suited for very clean environments (e.g. hospitals) or very dirty ones (e.g. production areas).

Touchpads can be partitioned into areas having different functionalities (e.g. motion-sensing, location-sensing and pressure-sensing areas), and can be used for absolute (sensing location) and relative (sensing motion) input.

Their most common use is for relative input as a replacement for the mouse in portable computers.

G.1.2 Functional properties

Functional properties of touchpads are related to the following:

- anchoring the body parts needed for holding and controlling the device (hand, fingers and thumb);
- anchoring the device on the work surface or on other objects;
- target acquisition;
- additional input through buttons, switches, etc.

The relevant properties for anchoring are the mechanical design of the housing and the buttons.

For target acquisition, the characteristics of the pad, the location and the dynamic properties of the buttons (motion, actuation and the interference of the actuation with the control of the device) are important.

G.1.3 Mechanical properties

Those mechanical properties of a touchpad relevant for usability are

- shape, profile of the housing,
- size of the sensitive area,
- smoothness of the sensitive area,

- buttons (position, shape, force, feedback), and
- form, location and visibility of other controls, if present.

G.1.4 Electrical properties

Those electrical properties of touchpads relevant for usability are

- cabling, and
- batteries, if included.

G.1.5 Maintainability-related properties

Maintainability properties relevant for usability are related to cleaning of the device.

G.1.6 Health- and safety-related properties

SAFETY PRECAUTIONS – Touchpads should not contain, or be made of, materials known to cause health and safety problems through skin contact or emissions.

There are no known user safety issues related to the mechanical design of touchpads. However, the surface properties of the touch-sensitive area (friction, smoothness) do need to be considered.

G.1.7 Interdependency with software

The operation of a touchpad is highly software-dependent. Normally, the user is allowed to introduce some relevant changes into the software that can considerably change the usability of the device. The most important change users can make is adjusting gain to suit his or her personal preferences.

The touchpad is usually delivered with, and operated by means of, either own-software that supports its entire functionality, or else it is operated with the aid of a “generic” driver that might possibly provide it with only limited capabilities.

Specific software can help to overcome limited abilities of the user.

EXAMPLE Most people are unable to draw a straight line regardless of the device they use (pen, stylus or mouse). The electronic equivalent of a mechanical ruler enables even people with very limited drawing ability to draw straight lines more precisely than skilled draughtsman and highly independent of the environment (e.g. in shaky vehicles).

G.1.8 Interdependency with use environment

The use of a touchpad is unlikely to influence the environment of the workplace, except for the noise of clicking. Its use requires much less space than that of a mouse.

The use of a touchpad can be affected by following the environmental conditions:

- vibration;
- instability of the support surface;
- relative humidity of the air (indirect through the sweat on the fingertips);
- temperature (indirect through the sweat on the fingertips).

In addition, sebum from the user’s fingers and hand can affect the use of a touchpad in a similar way to dirt from the environment.

G.2 Design requirements

G.2.1 Correspondence with generic design requirements

G.2.1.1 Appropriateness of touchpads

Since touchpads are pointing devices designed for being controlled by the hand and the fingers, an appropriate general-purpose design is recommended to enable users to achieve the maximum speed and accuracy for these limbs. However, most studies comparing different input devices show that the mouse is superior to the touchpad by means of effectiveness and efficiency if evaluated in isolation. Nevertheless, touchpads can prove to be more appropriate in use, if used together with a full-size keyboard for most applications with a graphical user interface or in any environment with limited space.

When equipped with software having the required functionality, touchpads can be used for pointing, dragging and clicking without additional hardware such as buttons or other controls. Thus a touchpad could be more appropriate than a mouse for some tasks.

Touchpads have a very low profile and can be integrated into other equipment such as desks and low-profile keyboards. The integration reduces homing time from the keyboard to the pointing device and back. This has many benefits for portable systems.

The touchpad's simple construction — no moving parts — leads to reliable and long-lived operation, making it suitable for environments where it will be subjected to intense use or where reliability is critical.

Touchpads can be operated in different modes. For example, the same device can be used as a pointing device and simulate at the same time a number of different other devices such as numeric pads or sliders.

G.2.1.2 Operability of touchpads

The obviousness of touchpad operation can be categorized into the following classes:

- C1 known or visible without the need for additional instructions and information;
- C2 detectable by the user by trial and error;
- C3 learnable by means of simple instructions;
- C4 learnable by means of special training.

C1 or C2 can be achieved in the cases of general-purpose devices and novice users since, next to the touch screen, a touchpad is the best device in terms of directness between action and response.

For C3 and C4 devices, the relevant information shall be included in the documentation. Such devices are likely to be used without additional keys for clicking and double clicking (or as replacement for the left and right mouse keys).

The predictability of the pointer's movement on the screen in the cardinal directions can be assumed if the device operates in two dimensions. In this respect, the touchpad is one of the best solutions for input devices.

Regarding consistency of operation (device operates and responds in the same manner) touchpads are among the best products available because of their high degree of independence from the environment (vibration, accelerations). However, depending on the software, their use can be severely hampered to a greater or lesser degree by perspiration of the user due to the relative humidity of the air, ambient temperature or work done previously.

G.2.1.3 User compatibility of touchpads

The design of a touchpad can accommodate the anthropometric characteristics of users to an extent where throughput and accuracy for pointing tasks are limited by the characteristics of the device. Thus, in general, touchpads cannot be considered fully compatible (C2).

Recent research suggests that the touchpad is inferior to the mouse as a pointing device in terms of performance and accuracy ^[15]. This is an indication of lower compatibility with user characteristics. However, for many applications the performance is sufficient.

G.2.1.4 Feedback

Touchpads provide visual feedback.

G.2.1.5 Controllability of touchpads

G.2.1.5.1 Reliability of device access

In terms of the likelihood of their unintended loss of control, touchpads are among the most reliable of devices.

G.2.1.5.2 Adequacy of device access

Quick and easy access to a touchpad is given if the device is located within the reach envelope of the user. Device access is easy and without the need for any intermediate devices.

G.2.1.5.3 Control access

The design of the device shall ensure that actuating any button or combination of buttons shall not move the focus of the pointer.

The buttons should be located so as to minimize finger extension.

G.2.2 Functional properties

G.2.2.1 Anchoring

The use of touchpads for fine-positioning accuracy requires the anchoring of some part of the fingers, hand or wrist — either on the input device or on the work surface — to create a stable relationship between the hand and the point of action. The design of the device need not include a space for anchoring, but this aspect should be considered in the design.

G.2.2.2 Resolution (task precision)

Input devices should be designed such that they achieve a resolution that supports the precision required by the task primitive. Since the most important task for a touchpad is pointing, this task primitive determines the resolution required. In general, touchpads cannot be counted among those input devices that enable the highest input resolution.

The task precision required for a touchpad can be categorized into the following classes:

- C1 high (an index of difficulty greater than 6);
- C2 medium (an index of difficulty greater than 4 and less than or equal to 6);
- C3 low (an index of difficulty greater than 3 and less than or equal to 4);
- C4 very low (an index of difficulty less than or equal to 3).

For a (separate) touchpad with operating systems based on GUI (graphical user interface) and for general-purpose applications, the category shall be determined for the following keyboard utilization (see Figure B.2):

- full-size keyboard located with alphanumeric zone centred in front of the user;
- shoulder width for 5th percentile female of the intended user population;
- overall length of keyboard at least the length of a full-size desktop keyboard (420 mm).

NOTE This position is not an optimum working position.

If the device is part of a more complex unit (e.g. portable computer), the category shall be determined for the typical use of that device.

The method by which the level of task precision has been determined shall be indicated.

G.2.2.3 Button design

G.2.2.3.1 Button motion

The device should be so designed that during its intended use the fingers are able to make contact and actuate buttons without excessive deviation from a neutral posture.

NOTE “Excessive” means, for example, interfering with accuracy or causing muscular strain.

Button contact surfaces should be perpendicular to the displacement direction of the button and to the motion of the finger during flexion.

G.2.2.3.2 Button actuation

It should be possible to press the buttons of a touchpad without unintentionally moving the device.

G.2.2.3.3 Button activation

The input device should be designed so as to be resistant to inadvertent button activation during its intended use.

G.2.2.3.4 Button shape

Buttons should be shaped so as to assist finger positioning and button actuation.

G.2.2.3.5 Button force

Buttons should have a displacement force within the range of 0,5 N to 1,5 N, until actuation.

Button force should be minimized without compromising usability.

G.2.2.3.6 Button displacement

Buttons intended for providing kinaesthetic feedback should have a minimum displacement of 0,5 mm. The maximum displacement shall be 6 mm.

G.2.2.3.7 Inadvertent pointer movement

The input device should be designed so that inadvertent button actuation does not cause unintentional movement of the pointer.

G.2.2.3.8 Button lock

The input device shall be designed so that a hardware or software lock can be provided for buttons that need to be continuously depressed for the duration of a task primitive such as dragging, tracing or free-hand input.

G.2.2.4 Consideration of handedness

Touchpads should be operable by the use of either hand; alternatively, right and left-handed devices should be available. Since the form of the touchpad always allows this, problems that might possibly arise can be due to the shape and location of other controls or the position of a touchpad on another device such as a keyboard.

The shape and location of the controls should be selected so as to support ambidextrous use of the device.

G.2.2.5 Resolution consistency

The resolution of a touchpad shall be independent of position.

Nevertheless, the resolution may be changed by the software or the user. Under some circumstances it can also be useful to create different resolutions for different parts of a target.

G.2.3 Mechanical properties

G.2.3.1 Size

Although the absolute size of the sensitive area has a certain relationship to the maximum achievable effectiveness and efficiency, both the software and the contact strategy mainly determine the usability of a device. For this reason, no advice can be given for the absolute size of devices with comparable dimensions.

G.2.3.2 Unintended slippage

The base of the device shall not be able to be moved unintentionally during intended use.

G.2.3.3 Actuation (dragging the finger)

The surface properties of the sensitive area and the sensing mechanism should be selected so as to enable the user to control the device without undue pressure. If the pressure is too high, effectiveness could suffer. In addition, the fingertips may also suffer through friction between the device and the skin.

G.2.3.4 Displacement

A touchpad is not a displacement device.

G.2.3.5 Button location

The buttons shall be located such that their use does not interfere with the operation of the touchpad and/or the keyboard if the device is mounted in the same housing as the keyboard.

The shape and location of the controls (buttons, wheel) should be selected so as to support ambidextrous use of the device.

G.2.4 Electrical properties

For touchpads that do not require an external power supply, electrical properties are unrelated to usability.

The influence of cabling on the operation of a touchpad does not affect the usability of the device.

Electromagnetic influences on other equipment at the same workstation may be considered irrelevant, owing to regulations for electromagnetic compatibility.

The weight of the touchpad is only relevant for the friction between the support surface and the underside of the device. Additional batteries do not affect it.

G.2.5 Maintainability-related properties

Touchpads do not require user maintenance other than cleaning. Since their simple mechanical design makes them less prone than other devices to collecting dust or dirt and greater resistance to spills of beverages, etc., touchpads can be a good choice for work areas where other devices are likely to fail.

G.2.6 Health- and safety-related properties

SAFETY PRECAUTIONS – Touchpads should not contain, or be made of, materials known to cause health and safety problems through skin contact or emissions.

Edges and corners on the housing of touchpads shall not cause discomfort or injury. This requirement is met if the minimum radius is 2 mm for edges and 3 mm for corners.

G.2.7 Interdependency with software

If dedicated software is not delivered together with a device, the documentation shall specify the manner in which the device is to be operated to achieve the intended level of effectiveness and efficiency. The documentation shall specify the setup of the device. It should be possible to test the effects of the settings.

G.2.8 Interdependency with use environment

The interdependency of the operation of the touchpad and the use environment is rather low. Having no puck to slide or bump, the pointer once placed on the screen “stays put”, thus making the device well suited for pointing tasks in environments subject to vibration or motion (e.g. cars, trains, boats, cockpits).

The influence of vibration can be reduced by adequate design of those parts that can be used to anchor parts of the hand or fingers during actuation.

G.3 Documentation

The user information shall include the following:

- optimum location of the device for best effectiveness, efficiency and postural comfort;
- best location of the device for concurrent use with a keyboard;
- features of the hardware/software that can improve postural comfort or reduce biomechanical load (setup for different buttons, changes in the setup to relieve fingers and thumb, etc.);
- instructions for improving the use of additional features (e.g. multi-tapping on the pad instead of the use of buttons).

Annex H (normative)

Tablets and overlays

H.1 Properties of tablets

H.1.1 General

Tablets are devices designed for the input of absolute positional information. Their use requires a mechanical intermediary, such as a stylus or puck, between the hand and the sensing mechanism. Tablets allow input in two dimensions. Unlike mice or joysticks, a tablet can be made to sense multiple points of contact.

Tablets are designed in a variety of sizes, from small to large. They can be partitioned into areas having different functionalities (e.g. motion-sensing, location-sensing or pressure-sensing areas) or resolution, and can be used for absolute (sensing location) and relative (sensing motion) input.

H.1.2 Functional properties

The functional properties of tablets are related to the following:

- anchoring the body parts needed for holding and controlling the device (hand, fingers and thumb);
- anchoring the device on the work surface or on other objects;
- target acquisition;
- additional input through buttons, switches etc.

The relevant properties for anchoring are the mechanical design of the housing and the buttons.

For target acquisition, the characteristics of the sensitive area, the location and the dynamic properties of the buttons (motion, actuation and the interference of the actuation with the control of the device) are important.

H.1.3 Mechanical properties

Those mechanical properties of a tablet (see Figure H.1) relevant for usability are

- shape, profile of the housing (height, depth and slope),
- size of the sensitive (active) area,
- size of the inactive area,
- buttons (position, shape, force, feedback),
- form, location and visibility of other controls, if present,
- homing facility or the stylus,
- smoothness of the surface (relevant for specular reflections and contact with the stylus), and
- transmittance of the cover (relevant for using overlays).

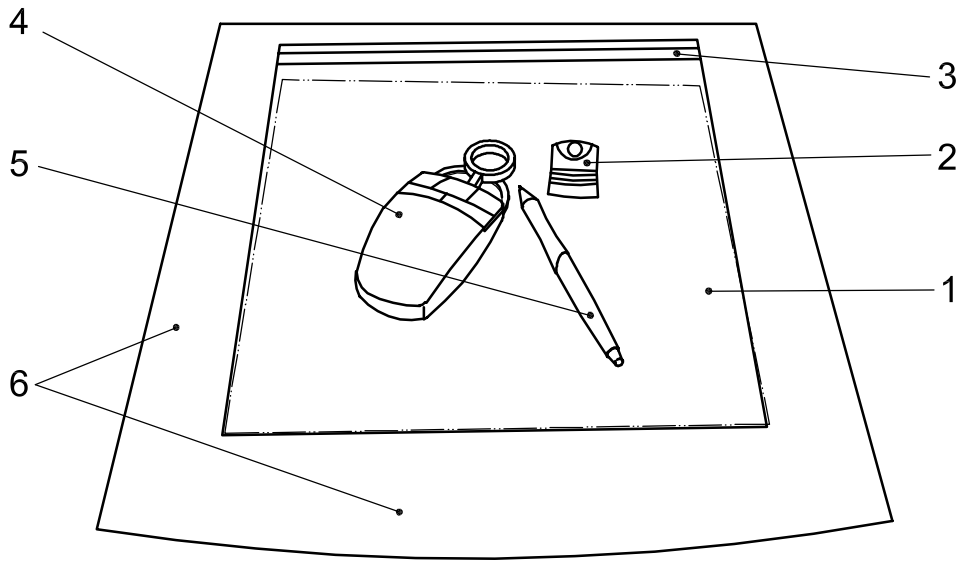

Key

- 1 sensitive area, cover for the overlay
- 2 homing utility for the stylus
- 3 area with virtual buttons
- 4 puck
- 5 stylus
- 6 inactive area

Figure H.1 – Tablet with areas and accessories

H.1.4 Legibility and visibility related properties

Tablets and overlays used with them possess surfaces of considerable size, partly with visual information on them (e.g. characters, other graphical symbols or icons). For this visual information, requirements similar to those for other visual displays apply. The likelihood of errors or discomfort due to reflected glare is somewhat higher than with monitors because of the horizontal orientation of most tablets.

Relevant properties treated in this part of ISO 9241 are

- legibility of legends and graphic symbols,
- size of legends and graphic symbols,
- colour and contrast legends and graphic symbols, and
- reflections and glare on the tablet or overlay.

H.1.5 Electrical properties

Those electrical properties of tablets relevant for usability are

- cabling, and
- batteries, if included.

H.1.6 Maintainability-related properties

Those maintainability properties relevant for usability are related to cleaning of the device and its accessories. Some devices can also require the changing of the stylus tip.

H.1.7 Health- and safety-related properties

There are no known user safety issues related to the mechanical design of a tablet in general.

The use of tablets involves prolonged skin contact with the surface. For this reason, chemical properties (material, emissions) and thermal aspects shall be considered.

H.1.8 Interdependency with software

The operation of a tablet is highly software-dependent. Normally, the user is allowed to introduce some relevant changes into the software that can considerably change the usability of the device. The most important change users can make is the partitioning of the active area of the device to suit his or her personal preferences. This action can not only modify the usability of a given device in general, but also considerably change the biomechanical load (see Figure H.2).

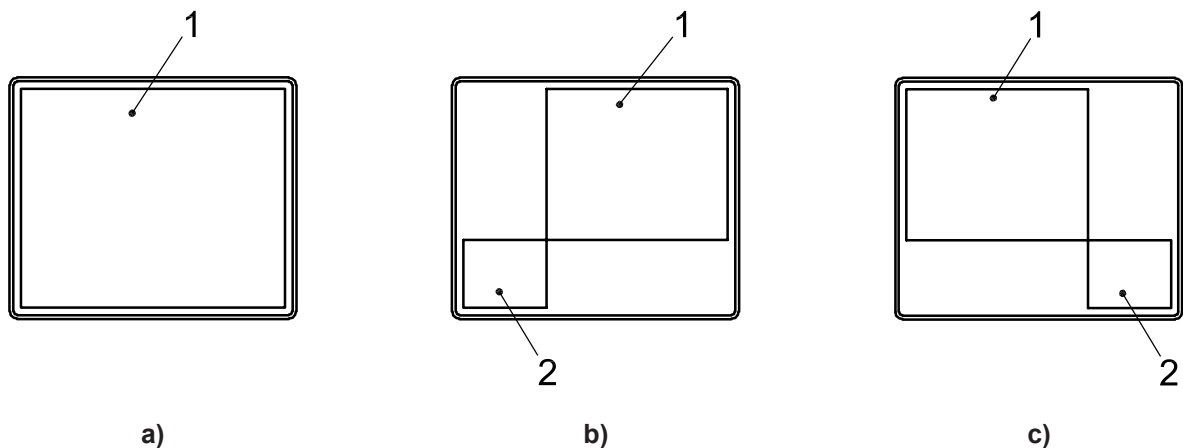

NOTE The entire active area, 1, in a), can be used to map either the entire screen or a relevant part of it, but with the result that access to some parts of the tablet requires moving the arms or even the body to reach them. Partitions 1 and 2 in b) and c) map the relevant screen area but with different resolution and ease of access.

Figure H.2 – Partitioning of a tablet (e.g. for right- or left-handed use)

H.1.9 Interdependency with use environment

The use of a tablet is unlikely to influence the environment of the workplace. However, depending on its size, a tablet can require a great deal of space, and the inactive area around the sensitive area can occupy up to 50 % of the overall area of the device.

The use of a tablet can be affected by the following environmental conditions:

- vibration;
- instability of the support surface.

H.2 Design requirements

H.2.1 Correspondence with generic design requirements

H.2.1.1 Appropriateness of tablets

Since tablets are pointing devices designed to be controlled by the arm, hand and the fingers, an appropriate general-purpose design is recommended to enable users to achieve the maximum speed and accuracy for these limbs. In general, tablets are designed to achieve the highest possible input precision. To achieve this, there is, however, a compromise involved between space requirements and the effectiveness that can be achieved. Since most applications require an additional input device (usually a keyboard), the appropriateness of a given tablet depends on the role of this additional device for the application.

Even if a full-size keyboard with the smallest footprint is used and the tablet is placed as close to it as possible, the “far end” of the active area of an A4 sized tablet is about 600 mm from the median (sagittal) plane of the body. Since the shoulder breadth of adults lies between 323 mm (5th percentile female of European origin) and 388 mm (95th percentile, male of European origin), any user will need an arm movement wide of the reach area in order to access the corresponding location on the screen. Moreover, if a stylus is used, the tip could slide more easily because of the tilt of the device. Thus, effectiveness and efficiency measured under these conditions will be far below the maximum achievable values under optimum conditions (tablet positioned in optimum reach area). This means that a smaller tablet could be more appropriate than a device with a wider sensitive area, and that other types of input devices with lower nominal resolution can achieve a higher appropriateness than a tablet with much higher resolution and a larger sensitive area.

H.2.1.2 Operability of tablets

The obviousness of tablet operation (pointing) can be categorized into the following classes:

- C1 known or visible without the need for additional instructions and information;
- C2 detectable by the user by trial and error;
- C3 learnable by means of simple instructions;
- C4 learnable by means of special training.

C1 or C2 can be achieved in the cases of general-purpose devices and novice users since, next to the touch screen, a tablet is the best device in terms of directness between action and response. Some tablets even include a visual display to achieve the same directness as a touch screen — and with much higher effectiveness. Access to additional functionality (use in different modes, programming virtual buttons, etc.) can require more instructions, thus making use less obvious. For C3 and C4 devices, the relevant information shall be included in the documentation.

The predictability of the pointer’s movement on the screen in the cardinal directions can be assumed if the device operates in two dimensions. In this respect, the tablet is one of the best input devices available.

Regarding consistency of operation (device operates and responds in the same manner), tablets are not among the best available products because of their lack of independence from the environment (vibration, accelerations). Nevertheless, in well-designed or -protected work areas and if positioned on stable support surfaces, tablets are likely to display consistent behaviour.

H.2.1.3 User compatibility of tablets

The design of a tablet can accommodate the anthropometric characteristics of users to an extent where throughput and accuracy for pointing tasks are not limited by the characteristics of the device. Thus, in general, tablets can be considered fully compatible (C1) if sized and positioned in the reach area in an appropriate way.

The most common mechanical intermediary used for pointing (stylus) results in a posture more neutral than during mouse use and thus appears to be a biomechanically superior input device. In addition, the input of absolute positional information requires less repetitive movements than relative input with dragging and lifting the mouse.

H.2.1.4 Feedback

Tablets provide visual feedback.

H.2.1.5 Controllability of tablets

H.2.1.5.1 Reliability of device access

As far as the likelihood of unintended loss of control is concerned, tablets are considered as being among the most reliable of devices.

H.2.1.5.2 Adequacy of device access

Quick and easy access to a tablet is given if the device is located within the reach envelope of the user. Device access requires intermediate devices that need time for homing and appropriate positioning for the accessory.

H.2.1.5.3 Control access

The design of the device shall ensure that actuating any button or combination of buttons shall not move the focus of the pointer.

H.2.2 Functional properties

H.2.2.1 Anchoring

The use of tablets for fine-positioning accuracy requires anchoring some part of the fingers, hand or wrist — either on the input device or on the work surface — to create a stable relationship between the hand and the point of action. The design of the device does not need to include a space for anchoring. However, it should consider this aspect. In general, the entire surface of the tablet can be used for anchoring the hand. Pointing to the extreme positions of the active area requires either an inactive area to the left and right of the device, and in front of the active area, or a flat profile that enables the use of the support surface for anchoring.

H.2.2.2 Resolution (task precision)

Input devices should be designed to achieve a resolution that supports the precision required by the task primitive. Since the most important task for a tablet is pointing, this task primitive determines the resolution required. In general, tablets are counted as being among those input devices that enable the highest input resolution.

The task precision required for a tablet can be categorized into the following classes:

- C1 high (an index of difficulty greater than 6);
- C2 medium (an index of difficulty greater than 4 and less than or equal to 6);
- C3 low (an index of difficulty greater than 3 and less than or equal to 4);
- C4 very low (an index of difficulty less than or equal to 3).

For a tablet with operating systems based on GUI (graphical user interface) and for general-purpose applications, the category shall be determined for the following keyboard utilization (see Figure B.2):

- full-size keyboard located with alphanumeric zone centred in front of the user;
- shoulder width for 5th percentile female of the intended user population;
- overall length of keyboard is at least the length of a full-size desktop keyboard (420 mm).

NOTE This position is not an optimum working position.

The method by which the level of task precision has been determined shall be indicated.

H.2.2.3 Button design

H.2.2.3.1 General

The use of a tablet for pointing is not necessarily associated with the use of physical buttons. Where buttons are used, they can be positioned on the tablet itself or on the puck and the stylus. For some actions, the keys of a keyboard can be used. The guidance given in this part of ISO 9241 is only for any buttons physically present on the tablet.

H.2.2.3.2 Button motion

The device should be so designed that during its intended use the fingers are able to make contact and actuate buttons without excessive deviation from a neutral posture.

NOTE “Excessive” means, for example, interfering with accuracy or causing muscular strain.

Button contact surfaces should be perpendicular to the displacement direction of the button and to the motion of the finger during flexion.

H.2.2.3.3 Button actuation

It should be possible to press the buttons of a tablet without unintentionally moving the device.

H.2.2.3.4 Button activation

The input device should be designed so as to be resistant to inadvertent button activation during its intended use.

H.2.2.3.5 Button shape

Buttons should be shaped so as to assist finger positioning and button actuation.

H.2.2.3.6 Button force

Buttons should have a displacement force within the range of 0,5 N to 1,5 N until actuation.

Button force should be minimized without compromising usability.

H.2.2.3.7 Button displacement

Buttons intended for providing kinaesthetic feedback should have a minimum displacement of 0,5 mm. The maximum displacement shall be 6 mm.

H.2.2.3.8 Inadvertent pointer movement

The input device should be designed so that inadvertent button actuation does not cause unintended movement of the pointer.

H.2.2.3.9 Button lock

The input device shall be designed so that a hardware or software lock can be provided for buttons that need to be continuously depressed for the duration of a task primitive such as dragging, tracing or free-hand input.

H.2.2.4 Consideration of handedness

Tablets should be operable by the use of either hand; alternatively, right and left-handed devices should be available. Since the form of the tablet always allows this, problems that might possibly arise can be due to, for example, wrong partitioning. Such problems are, however, either related to software or caused by its incorrect use; because of this, the instructions in the documentation (see Clause 9 and H.3) are of particular importance.

The shape and location of the controls should be selected so as to support ambidextrous use of the device.

H.2.2.5 Resolution consistency

The resolution of a tablet shall be independent of position. In practice, this equates to the requirement of at least one setting with equal resolution over the entire sensitive area.

For certain purposes, it can be useful to design a tablet with partitions having different resolutions or functionalities, in which case the requirement will apply to the contiguous space to be used for pointing.

Nevertheless, the resolution may be changed by the software or the user. Under some circumstances it can also be useful to create different resolutions for different parts of a target.

H.2.2.6 Control display gain

The control display gain should be adjustable according to intended user needs and task requirements.

H.2.2.7 Actuation force on tablet or overlay

For functions that require intermittent input against the tablet or overlay, the maximum force required for input should not exceed 1,0 N.

H.2.3 Mechanical properties

H.2.3.1 Size

Although the absolute size of the sensitive area has a certain relationship to the maximum achievable effectiveness and efficiency, both the software and the contact strategy mainly determine the usability of a device. In addition, the usability of tablets with a size greater than the reach space of the user can depend on the posture (sitting or standing) and orientation of the device in space (horizontal, vertical or near horizontal or vertical). For these reasons, no advice can be given on the absolute size of devices with comparable dimensions.

H.2.3.2 Height, depth and slope

If the tablet is incorporated into the workstation, the tablet's design (height, depth and slope) should allow the user to adopt the design reference posture.

H.2.3.3 Tablet and overlay contact surface

The user contact surface of the tablet and overlay should be flat and smooth, and prevent the tip of the stylus from sliding.

H.2.3.4 Unintended slippage

The base of the device shall not be able to be moved unintentionally during intended use.

H.2.3.5 Actuation (pressing for clicking)

The surface properties of the sensitive area (smoothness, friction coefficient) are relevant for usability when the tablet is used in association with a stylus. For accessing the remote areas of the tablet, the user will need to change the tilt of the stylus, thus making it easier to slide. If the setting of the software requires pressing the tip against the surface, the target could move during or after the action.

The surface properties should be selected in order to minimize the effect associated with the target selection. Since the effect is related to the characteristics of the stylus, the setting of the software and the size and location of the device in the reach area, no normative provision can be given in this part of ISO 9241.

H.2.3.6 Displacement

A tablet is not a displacement device.

H.2.3.7 Button location

Buttons, if present, shall be located such that their use does not interfere with the operation of the stylus or puck.

The shape and location of the controls (buttons, wheel) should be selected so as to support ambidextrous use of the device.

H.2.3.8 Overlays ± attachment, movement and flatness

The overlay should be easily and simply attached to, and removed from, the tablet. It should not be able to accidentally become detached from the tablet during normal operation.

The overlay should be flat when placed on the tablet.

H.2.4 Legibility and visibility related properties

H.2.4.1 Legibility of legends and graphic symbols

All legends on the tablet and overlay shall be legible from the design viewing distance. Graphical symbols should be identifiable from the design viewing distance.

H.2.4.2 Size of legends and graphic symbols

The nomenclature for the symbols, capital letters and numbers on a tablet and overlay shall have a minimum perceived height of 16' of visual arc at the design viewing distance.

The recommended perceived height is 20' of visual arc.

H.2.4.3 Width to height ratio of legend

The ratio of the width of the capital letters (except capital i: l) to the height of the letter shall be between 0,5:1 and 1:1 of the character height.

H.2.4.4 Height to stroke width ratio of legend

The ratio of the height of a capital letter to its stroke width shall be between 5:1 and 14:1.

H.2.4.5 Colour and contrast of legends and graphic symbols

For colours that are intended to differentiate information, the colour difference should be obvious and easily perceivable.

Primary legends and symbols shall have a minimum luminance contrast ratio of at least 3:1. A lower luminance contrast ratio is acceptable for legends and symbols other than the principal ones, provided that colour differences ensure that they are recognizable.

H.2.4.6 Tablet and overlay surface reflections

Reflections or glare from the tablet and overlay surface should not interfere with the visibility of imprinted images on the tablet or overlay, nor reduce visual efficiency or comfort.

NOTE Overlay images can be imprinted onto tablets or be of removable material.

H.2.4.7 Function grouping

Groups of functions on an overlay or tablet should be easily and quickly distinguishable.

H.2.5 Electrical properties

For tablets that do not require an external power supply, electrical properties are unrelated to usability.

The influence of cabling on the operation of a tablet does not affect the usability of the device.

Electromagnetic influences on other equipment at the same workstation may be considered irrelevant, owing to regulations for electromagnetic compatibility.

NOTE Tablets can interfere with the cabling of other devices in the vicinity and the signals transported on them.

H.2.6 Maintainability-related properties

Tablets do not require user maintenance other than cleaning. Since their simple mechanical design makes them less prone to collecting dust or dirt than other devices and gives them greater resistance to spills of beverages, etc., tablets can be a good choice for work areas where other devices (e.g. mice) are likely to fail.

If changing the tip of the stylus by the user is allowed, no special tools should be required.

H.2.7 Health- and safety-related properties

SAFETY PRECAUTIONS – Tablets should not contain, or be made of, materials known to cause health and safety problems through skin contact or emissions.

The material of the surface of the tablet and the overlay should be selected in consideration of low thermal conductivity. While health- and safety-related standards such as ISO 13732-1 consider upper limits for surfaces that users can come in touch with for the design of input devices, low temperatures are more relevant. Objects with low surface temperatures may lead to energy loss if the user has prolonged contact with them. Tablets belong to surfaces for which contact periods in the range of 10 s to many minutes should be considered.

There is insufficient knowledge to justify requirements for temperatures of tablet surfaces lower than usual skin temperature of the arm and the hand.

Edges and corners on tablets shall not cause discomfort or injury. This requirement is met if the minimum radius is 2 mm for edges and 3 mm for corners.

H.2.8 Interdependency with software

If dedicated software is not delivered together with a device; the documentation (see H.3) shall specify the manner in which the device is to be operated to achieve the intended level of effectiveness and efficiency.

The documentation shall specify the setup of the device. It should be possible to test the effects of the settings.

H.2.9 Interdependency with use environment

The interdependency of the operation of tablets and the use environment is greater than that of touchpads. The most important factor is vibration of the device and/or the user. Reflected glare on the surfaces is another important issue.

The influence of vibration can be reduced by an adequate design of the parts that can be used to anchor parts of the hand or fingers during actuation. If the design of a tablet does not include space for anchoring the hand or finger, the profile of the device should enable the user to anchor parts of the body on the work surface.

Reducing the required space can considerably improve posture, especially in concurrent use of a tablet and keyboard, as well as effectiveness, and for this reason the inactive area should be as small as possible — without compromising the usability of the device.

Provision for reflected glare is given in H.2.4.

H.3 Documentation

The user information shall include the following:

- optimum location of the device for best effectiveness, efficiency and postural comfort;
- best location of the device for concurrent use with a keyboard;
- features of the hardware/software that can improve postural comfort or reduce biomechanical load (setup for different buttons, changes in the setup to relieve fingers and thumb, partitioning the active area to improve postural comfort, etc.);
- instructions for improving the use of additional features that can help reduce biomechanical load (using a single button to generate a double click, setup for software for dragging objects without continuous pressing of buttons, etc.);
- instructions for improving the legibility of the symbols and reducing reflected glare if the visible surfaces cannot be matt-finished without compromising usability (e.g. if an overlay cannot be matt for hygienic reasons).

Annex I (normative)

Styli and light-pens

I.1 Properties of styli and light-pens

I.1.1 General

Styli and light-pens are hand-held devices used for pointing. While the use of a stylus requires a sensitive area on a tablet-like device (tablet, visual display, etc.) that can sense the presence of its tip without further, continuous action, light-pens are used together with a light-sensitive device.

I.1.2 Functional properties

The functional properties of styli and light-pens are related to the following:

- anchoring the body parts needed for holding and controlling the device (grasping by hand, fingers and thumb);
- target acquisition;
- additional input through buttons, switches, etc.

The relevant properties for anchoring are the mechanical design of the housing and the buttons.

For target acquisition, the location and the dynamic properties of the buttons (motion, actuation and the interference of the actuation with the control of the device) are important.

I.1.3 Mechanical properties

Those mechanical properties of a stylus (see Figure I.1) relevant for usability are

- shape, profile of the housing (diameter, length and weight),
- buttons (position, shape, force, feedback), and
- homing facility of the stylus.

I.1.4 Electrical properties

Those electrical properties of styli and light-pens relevant for usability are

- cabling, if present, and
- batteries, if included.

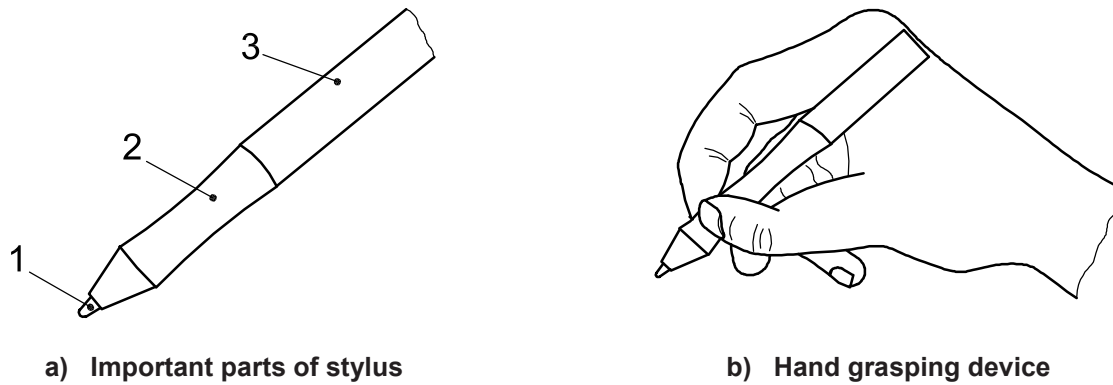

Key

- 1 tip
- 2 space for anchoring fingers and thumb
- 3 shaft

Figure I.1 – Stylus

I.1.5 Maintainability-related properties

Maintainability-related properties relevant for usability are related to changing the tip of the stylus.

I.1.6 Health- and safety-related properties

There are no known user health and safety issues related to the mechanical design of styli and light-pens in general. However, the use of styli and light-pens involves prolonged skin contact with the surface. For this reason, chemical properties (material, emissions) shall be considered.

I.1.7 Interdependency with software

The operation of a stylus is software-dependent. The user can adjust the optimum range of tilt for better access to the remote parts of the tablet, the feel of the tip and the function of a button (e.g. click, double-click, click-lock).

I.1.8 Interdependency with use environment

The use of a stylus or a light-pen is unlikely to influence the environment.

The use of either device can be affected by the following environmental conditions:

- vibration;
- instability of the support surface.

These conditions, however, are affect tablets and other devices together with which the devices under consideration are used.

I.2 Design requirements

I.2.1 Correspondence with generic design requirements

I.2.1.1 Appropriateness of styli and light-pens

Styli and light-pens are, by their mechanical shape, related to some of the oldest tools that have been designed. Their use is not considerably affected by the use of additional input devices. Thus, their appropriateness does not need to be considered separately from their usability.

I.2.1.2 Operability of styli and light-pens

The obviousness of operation (pointing) can be categorized into four classes:

- C1 known or visible without the need for additional instructions and information;
- C2 detectable by the user by trial and error;
- C3 learnable by means of simple instructions;
- C4 learnable by means of special training.

C1 or C2 can be achieved for simple actions in the cases of general-purpose devices and novice users. Access to additional functionality (e.g. use in different modes or programming buttons for performing different actions such as executing macros) can require further instructions, thus making use less obvious. For C3 and C4 devices, the relevant information shall be included in the documentation.

The predictability of the pointer's movement on the screen in the cardinal directions can be assumed if the device operates in two dimensions.

Regarding consistency of operation (device operates and responds in the same manner): because tablets and similar devices used together with the styli and light-pens are not counted as being among the best available products, owing to their lack of independence from the environment (vibration, accelerations), the styli and light-pens can similarly suffer. However, in well-designed or -protected work areas, and if positioned on stable support surfaces, tablets — and thus the styli and light-pens used with them — are likely to display consistent behaviour.

I.2.1.3 User compatibility of styli and light-pens

Since the mechanical shape of styli and light-pens resembles some of the oldest tools, user compatibility can be assumed if the requirements given in I.2.2 and I.2.3 have been satisfied.

I.2.1.4 Feedback

Styli provide kinaesthetic feedback.

I.2.1.5 Controllability of styli and light-pens

I.2.1.5.1 Reliability of device access

As far as the likelihood of unintended loss of control is concerned, styli and light-pens are considered very reliable devices.

I.2.1.5.2 Adequacy of device access

Quick and easy access to a stylus or light-pen is given if the device is located within the reach envelope of the user. Device access may require an accessory for homing.

I.2.1.5.3 Control access

The design of the device shall ensure that actuating any button or combination of buttons shall not move the focus of the pointer.

I.2.2 Functional properties

I.2.2.1 Anchoring

Using styli for fine-positioning accuracy requires the anchoring of some part of the fingers or the hand on the input device (see Figure I.1).

I.2.2.2 Resolution (task precision)

The resolution is determined by other equipment rather than by the physical design of the stylus.

I.2.2.3 Button design

I.2.2.3.1 General

Styli can include buttons, but there are stylus designs without buttons or any comparable controls.

I.2.2.3.2 Button motion

The device should be designed so that during its intended use the fingers are able to make contact and actuate buttons without excessive deviation from a neutral posture.

NOTE "Excessive" means, for example, interfering with accuracy or causing muscular strain.

Button contact surfaces should be perpendicular to the displacement direction of the button and to the motion of the finger during flexion.

I.2.2.3.3 Button actuation

It shall be possible to actuate and activate the buttons of a stylus without causing unintentional movement of the device.

I.2.2.3.4 Button activation

The input device should be designed so as to be resistant to inadvertent button activation during its intended use.

I.2.2.3.5 Button shape

Buttons should be shaped so as to assist finger positioning and button actuation. The shape of the buttons should be selected in consideration of the posture the hand adopts for grasping.

A selector button should have a contact surface that contains a circular area with a diameter not less than 5 mm.

I.2.2.3.6 Button force

Buttons should have a displacement force within the range of 0,3 N to 1,5 N, until actuation.

I.2.2.3.7 Button displacement

Buttons intended for providing kinaesthetic feedback should have a minimum displacement of 0,5 mm. The maximum displacement shall be 6 mm.

I.2.2.3.8 Inadvertent pointer movement

The input device should be designed such that inadvertent button actuation does not cause unintended movement of the pointer.

I.2.2.3.9 Button lock

The input device shall be designed so that a hardware or software lock can be provided for buttons that need to be continuously depressed for the duration of a task primitive such as dragging, tracing or free-hand input.

I.2.2.4 Consideration of handedness

The shape and location of the controls should be selected so as to support ambidextrous use of a device.

I.2.2.5 Actuation force on tablet or overlay

For functions that require intermittent input against the tablet or overlay, the maximum force required for input should not exceed 1,0 N.

I.2.2.6 Activation force

For continuous input using styli, the force required to activate the stylus on a tablet should be not greater than 1,5 N.

I.2.3 Mechanical properties

I.2.3.1 Size

Cylindrical styli and light-pens should be between 120 mm and 180 mm in length and 7 mm to 20 mm in diameter.

I.2.3.2 Weight

Styli and light-pens should have a mass between 10 g and 25 g.

I.2.3.3 Grasp surface

The grasp surface of the stylus and light-pen should be slip-resistant. This can be achieved by selecting appropriate surface characteristics or shape or a combination of both.

I.2.4 Electrical properties

For devices that do not require an external power supply, electrical properties are unrelated to usability.

The influence of cabling on the operation of a stylus or light-pen can affect the usability of the device. However, it is unlikely that cabling, if needed, will need to be selected for considerations of electrical safety. Thus, it can be assumed that the designer will be free to select a cable that does not affect usability. Many devices operate without cables.

Electromagnetic influences on other equipment at the same workstation may be considered irrelevant, owing to regulations for electromagnetic compatibility.

I.2.5 Maintainability-related properties

Maintainability-related issues for styli and light-pens are easily addressed. If changing the tip of the stylus by the user is allowed, no special tools should be required.

I.2.6 Health- and safety-related properties

SAFETY PRECAUTIONS – Styli and light-pens should not contain, or be made of, materials known to cause health and safety problems through skin contact or emissions.

Edges and corners on styli and light-pens shall not cause discomfort or injury. This requirement is met if the minimum radius for edges is 2 mm and for corners 3 mm. It does not apply to buttons.

I.2.7 Interdependency with software

If dedicated software is not delivered together with a device; the documentation (see I.3) shall specify the manner in which the device is to be operated to achieve the intended level of effectiveness and efficiency. The documentation shall specify the setup of the device. In general, such information is included in the documentation of the tablet or other device for which the stylus is being used.

It should be possible to test the effects of the settings.

I.2.8 Interdependency with use environment

The interdependency of the operation of tablets and the use environment is greater than in the case of touchpads. The most important factor is vibration of the device and/or user. Remedies against such influences are described in Annex G or H, as applicable to the device.

I.3 Documentation

The user information shall include the following (if not already included in the documentation for the tablet or other additional device):

- features of the hardware/software that can improve postural comfort or reduce biomechanical load (setup for different buttons, changes in the setup to relieve fingers and thumb, etc.);
- instructions for improving the use of additional features that can help reduce biomechanical load (using a single button to generate a double click, setup for software for dragging objects without continuous pressing of buttons, etc.).

Annex J (normative)

Touch-sensitive screens

J.1 Properties of touch-sensitive screens

J.1.1 General

Touch-sensitive screens are devices with a touch-sensitive area that also functions as a display used to manipulate the objects. Their size can vary from some square centimetres to wall-wide panels. Most such devices are similar to customary computer monitors equipped with functional units that sense the location of the finger. Touch-sensitive screens are the most direct input devices.

J.1.2 Functional properties

The functional properties of touch-sensitive screens are related to the following:

- size of the touch-sensitive area;
- inactive space of target;
- additional input through buttons, switches, etc.

J.1.3 Mechanical properties

Those mechanical properties of a touch-sensitive screen relevant for usability are

- overall size of the sensitive area, and
- size of the device (position in the reach area).

J.1.4 Electrical properties

Electrical properties of touch-sensitive screens are in general not relevant for usability, i.e., the usability related properties of a touch-sensitive screen can be selected without consideration of the power supply and electrical safety.

J.1.5 Maintainability-related properties

Maintainability properties relevant for usability are related to cleaning the screen, which usually collects sebum from finger tips on which dust and grime are later deposited.

NOTE Touch-sensitive displays can be utilized to reduce the maintenance required for the operation of some devices or functional units.

J.1.6 Health- and safety-related properties

There are no known user health and safety issues related to the mechanical design of touch-sensitive screens in general.

NOTE Some earlier models were subject to safety recall because of overheating of some parts. However, such incidences are not related to the specific feature that enables the device to sense touch.

The position of a device in the reach space could constitute a safety concern if it required raising the arm over the shoulder height of the user. Normally, this is related to the overall design of the unit into which the touch-sensitive screen is integrated.

J.1.7 Interdependency with software

The operation of touch-sensitive screens is software-dependent.

J.1.8 Interdependency with use environment

The use of a touch-sensitive screen is unlikely to influence the environment.

The use of a touch-sensitive screen can be affected by the following environmental conditions:

- dust and dirt;
- lighting.

J.2 Design requirements

J.2.1 Correspondence with generic design requirements

J.2.1.1 Appropriateness of touch-sensitive screens

Since the usability of a touch-sensitive screen is highly dependent on its position, its appropriateness is also closely related to the way in which the device is utilized (orientation in vertical or horizontal space, relative height to the user, inclination, lighting, etc.).

J.2.1.2 Operability of touch-sensitive screens

The obviousness of operation (pointing) can be categorized into the following classes:

- C1 known or visible without the need for additional instructions and information;
- C2 detectable by the user by trial and error;
- C3 learnable by means of simple instructions;
- C4 learnable by means of special training.

C1 can be achieved for simple actions in the case of general purpose-devices and novice users because of the nature of this input device (most direct absolute input by touching visible virtual objects). This is the reason why touch-sensitive screens are used, for example, for customer self-service terminals, electronic catalogues, promotional displays and public information directories in lobbies, shopping malls, trade shows, etc.

The predictability of the pointer's movement on the screen in the cardinal directions can be assumed.

Regarding consistency of operation (device operates and responds in the same manner), touch-sensitive screens are counted as being among the best products available because of their independence from the environment (vibration, accelerations).

J.2.1.3 User compatibility of touch-sensitive screens

Compatibility can be assumed if the requirements given in J.2.2 and J.2.3 have been satisfied.

J.2.1.4 Feedback

Touch-sensitive screens provide visual feedback.

J.2.1.5 Controllability of touch-sensitive screens

J.2.1.5.1 Reliability of device access

As far as the likelihood of unintended loss of control is concerned, touch-sensitive screens are considered very reliable devices.

J.2.1.5.2 Adequacy of device access

Quick and easy access to a touch-sensitive screen is given if the device is located within the reach envelope of the user in an optimum inclination. Adequacy of device access is highly dependent on its relative position to the user.

Selecting the acceptable location of a device requires a compromise between different aspects. Even where there is total freedom from other concerns, a “trade-off” needs to be made between good vision (optimum position for the display) and posture (optimum position for the manual access). If a device is to be used together with other input devices such as a keyboard, finding a balance between these aspects is far more difficult.

The design of a touch-sensitive screen should take into consideration that it is not likely to be positioned and used in the best available space within the reach area of the user. This means, for example, that the target size should be selected for lower resolution of the finger movements or that the optical properties of the screen and the target should be selected so as to facilitate good visibility under sub-optimal conditions.

J.2.1.5.3 Control access

Since the focus of the pointer is the object under the finger, and the same hand is not used for accessing additional controls, good control access is given.

J.2.2 Functional properties

J.2.2.1 Touch-sensitive area

For systems using a first-contact touch strategy, the size of the touch-sensitive area should be at least equal to the size of the 95th percentile male distal (digit 2) joint breadth. The touch-sensitive area should be increased if parallax results in a degradation in performance.

J.2.2.2 Inactive space of target

For touch-sensitive screens designed for first-contact touch activation, an inactive space having a width of at least 5 mm should be provided around each touch target.

NOTE For touch-sensitive screens designed for last-contact touch actuation, the inactive space can be less than 5 mm.

J.2.2.3 Target tracking

During a drag operation, the object or pointer being moved should track the finger or stylus, both temporally and spatially.

J.2.2.4 Target visibility (character size and contrast)

The area of the screen with the touch-sensitive location shall be designed so as to enable the user to easily recognize the graphic symbols and their captions and to correctly read alphanumeric information. To achieve this, certain characteristics concerning reflected glare and the image quality are required.

Relevant information for the design and operation of visual displays is given in the ISO 9241-300 subseries. For horizontally oriented screens, additional measures for preventing reflected glare can be needed, because all relevant standards deal with display surfaces with near-vertical orientation.

J.2.3 Mechanical properties

J.2.3.1 Orientation

If visibility is the overriding aspect for selecting the orientation of a device in space, the optimum slope will be about 30° to 35° (design reference posture sitting and standing according to ISO 9241-5). In this case, manual access is suboptimal to a certain degree.

If manual access is the overriding aspect, the orientation of the device should be near-horizontal. In this case, the screen is located at a position where reflected glare or loss of contrast due to ambient lighting could be a problem, the severity of which will depend on the specific technology used and the form of the surface.

If the final design of the unit containing a touch-sensitive screen is unknown, the properties of the screen should be selected to support the intended use.

J.2.3.2 Target location

Vertically-oriented touch-sensitive screens shall allow touch targets to be positioned below shoulder height. This means that the vertically oriented touch-sensitive screen is tiltable, moveable and height-adjustable so it can be operated with the arm/elbow supported by the work surface and inside the reach envelope of the intended user population.

Horizontally-oriented touch-sensitive screens shall allow touch targets to be positioned at or below elbow height and inside the reach envelope of the intended user population.

J.2.4 Electrical properties

There is no known requirement for electrical safety that can interfere with the usability of touch-sensitive screens.

J.2.5 Maintainability-related properties

The sensitive surface of the screen should facilitate easy cleaning.

The distance between the visible surface of the screen and the physical point of image generation is crucial for the blurring effect of the dirt film on the screen. CRT (cathode ray tube) displays with a thick glass tube face suffer more than flat screens.

J.2.6 Health- and safety-related properties

The requirements given in J.2.3.2 are applicable for the known health- and safety-related issues.

J.2.7 Interdependency with software

The requirements given in J.2.2 are applicable for the known software issues.

J.2.8 Interdependency with use environment

Dust and grime can affect the use of touch-sensitive screens to a higher degree than the use of other input devices and visual displays that are not touched with the fingers.

Moreover, the influence of lighting is higher both for horizontally- and vertically-oriented touch-sensitive screens. Horizontally-oriented screens are more prone to reflected glare.

J.3 Documentation

The user information shall include the following:

- features of the hardware/software that can improve postural comfort or reduce biomechanical load (e.g. optimum orientation of the device, optimizing for better visibility or for better manual access depending on the task);
- instructions for cleaning.

Annex K (informative)

Designing input devices to accommodate diverse users

K.1 General

This part of ISO 9241 gives requirements for, and guidance on, the design of input devices such that the limitations and capabilities of all users are considered. These include generic design requirements for input devices that apply independently from the context of use, specific design requirements for each type of device and guidance on how to evaluate and utilize a given device for a given task.

In general, the design of an input device is intended to be equitable, i.e. the design accommodates people with diverse abilities. The needs of users can vary with regard to the users' ability to perceive information statically presented on an input device or dynamically supplied by the input device, or in their ability to understand how to use the product or in their ability to operate the product. Some users will need to use assistive devices with, or in place of, input devices. For example, a user with tremor or having limited eye-hand coordination might need a special keyboard with increased spacing between the keys. However, it is preferable to accommodate all user requirements instead of using assistive technologies.

In some instances, the most practical or feasible means of achieving accommodation of diverse users can be through the use of software intended to be used with the input device, e.g., device drivers, rather than through the physical properties of the device. For example, it can be more practical to adjust key repeat rate via software controls than by building variable activation delays into a key switch circuit.

Because of the very nature of diversity, it is difficult and perhaps even contradictory to attempt to specify a unique set of design criteria that will accommodate all users. For example, a user with very limited strength could require that keys on an input device respond almost instantaneously to a light touch, yet a user with intention tremor could require that the keys respond only to a sustained, high level of force. At present, the research literature does not suffice to answer these accommodation questions — or at least, not at a level sufficient to allow specification.

Similarly, the current state of knowledge does not allow us to determine whether there is a single set of design criteria that will result in a universal input device suitable for all possible users. However, it is possible to provide designers with some general principles, leading to general guidelines, regarding features of input devices that will support accommodation.

K.2 General guidelines

K.2.1 Perception

Input devices — either separately or in combination with supporting software — should facilitate the ability of diverse users to perceive statically or dynamically displayed information such as

- key labels,
- key locations,
- feedback from operation of the device, and
- status of toggle keys, e.g. number lock and capital lock.

K.2.2 Operation

Input devices — either separately or in combination with supporting software — should facilitate the ability of diverse users to operate the input device by the following means:

- by not limiting the ability to use alternative means of carrying out input functions, e.g. assistive technologies;
- by minimizing the likelihood of accidental activation;
- by supporting error recovery;
- by the support of varying rates of user-provided input, e.g. keying rate.

K.2.3 Understanding

Input devices — either separately or in combination with supporting software — should facilitate the ability of diverse users to

- orient input device actions with changes to the associated displays or feedback, and
- apprehend the manner or method of using the device.

K.3 References

The following publications specifically address these aspects.

North Carolina State University, *Principles of Universal Design*, available at http://www.design.ncsu.edu/cud/about_ud/udprinciples.htm

ISO JTC1, Special Working Group on Accessibility. 2005. *User Needs Inventory*, document number ia050025, available at http://www.incits.org/tc_home/ia/iadocreg.htm

ISO 9241-20: *Ergonomics of human-system interaction – Part 20: Accessibility guidelines for information/communication technology (ICT) equipment and services*

CWA 14661:2003, *Guidelines to Standardisers of ICT products and services in the CEN ICT domain*

For other publications relevant to this part of ISO 9241, see the Bibliography.

Bibliography

- [1] ISO 6385, *Ergonomic principles in the design of work systems*
- [2] ISO 9241-5:1998, *Ergonomic requirements for office work with visual display terminals (VDTs) – Part 5: Workstation layout and postural requirements*
- [3] ISO 9241-6, *Ergonomic requirements for office work with visual display terminals (VDTs) – Part 6: Guidance on the work environment*
- [4] ISO 9241-110, *Ergonomics of human-system interaction – Part 110: Dialogue principles*
- [5] ISO 9241-300, *Ergonomics of human-system interaction – Part 300: Introduction to electronic visual display requirements³⁾*
- [6] ISO 9241-302, *Ergonomics of human-system interaction – Part 302: Terminology for electronic visual displays³⁾*
- [7] ISO 9241-303, *Ergonomics of human-system interaction – Part 303: Requirements for electronic visual displays³⁾*
- [8] ISO 9241-305, *Ergonomics of human-system interaction – Part 305: Optical laboratory test methods for electronic visual displays³⁾*
- [9] ISO 9241-306, *Ergonomics of human-system interaction – Part 306: Field assessment methods for electronic visual displays³⁾*
- [10] ISO 9241-307, *Ergonomics of human-system interaction – Part 307: Analysis and compliance test methods for electronic visual displays³⁾*
- [11] ISO/IEC 9995 (all parts), *Information technology – Keyboard layouts for text and office systems*
- [12] ISO 11690-1, *Acoustics – Recommended practice for the design of low-noise workplaces containing machinery – Part 1: Noise control strategies*
- [13] ISO 13732-1:2006, *Ergonomics of the thermal environment – Methods for the assessment of human responses to contact with surfaces – Part 1: Hot surfaces*
- [14] IEC 60950 (all parts), *Information technology equipment – Safety*
- [15] MACKENZIE, I. S., KAUPPINEN, T., SILFVERBERG, M. (2001), *Accuracy Measures for Evaluating Computer Pointing Devices*. In: Beaudouin-Lafon, Michel, Jacob, Robert J. K. (ed.), *Proceedings of the ACM CHI 2001 Human Factors in Computing Systems Conference*, March 31–April 5, 2001, Seattle, Washington, USA, pp. 9–16
- [16] SILFVERBERG, M., MACKENZIE, I. S., KAUPPINEN, T. (2001), *An Isometric Joystick as a Pointing Device for Handheld Information Terminals*. In: *Graphics Interface 2001*, June 7-9, 2001, Ottawa, Ontario, Canada, pp. 119–126
- [17] ISO 9241-4, *Ergonomic requirements for office work with visual display terminals (VDTs) – Part 4: Keyboard requirements*
- [18] ISO 9241-9, *Ergonomic requirements for office work with visual display terminals (VDTs) – Part 9: Requirements for non-keyboard input devices*

3) To be published.

British Standards Institution (BSI)

BSI is the national body responsible for preparing British Standards and other standards-related publications, information and services.

BSI is incorporated by Royal Charter. British Standards and other standardization products are published by BSI Standards Limited.

About us

We bring together business, industry, government, consumers, innovators and others to shape their combined experience and expertise into standards-based solutions.

The knowledge embodied in our standards has been carefully assembled in a dependable format and refined through our open consultation process. Organizations of all sizes and across all sectors choose standards to help them achieve their goals.

Information on standards

We can provide you with the knowledge that your organization needs to succeed. Find out more about British Standards by visiting our website at bsigroup.com/standards or contacting our Customer Services team or Knowledge Centre.

Buying standards

You can buy and download PDF versions of BSI publications, including British and adopted European and international standards, through our website at bsigroup.com/shop, where hard copies can also be purchased.

If you need international and foreign standards from other Standards Development Organizations, hard copies can be ordered from our Customer Services team.

Subscriptions

Our range of subscription services are designed to make using standards easier for you. For further information on our subscription products go to bsigroup.com/subscriptions.

With **British Standards Online (BSOL)** you'll have instant access to over 55,000 British and adopted European and international standards from your desktop. It's available 24/7 and is refreshed daily so you'll always be up to date.

You can keep in touch with standards developments and receive substantial discounts on the purchase price of standards, both in single copy and subscription format, by becoming a **BSI Subscribing Member**.

PLUS is an updating service exclusive to BSI Subscribing Members. You will automatically receive the latest hard copy of your standards when they're revised or replaced.

To find out more about becoming a BSI Subscribing Member and the benefits of membership, please visit bsigroup.com/shop.

With a **Multi-User Network Licence (MUNL)** you are able to host standards publications on your intranet. Licences can cover as few or as many users as you wish. With updates supplied as soon as they're available, you can be sure your documentation is current. For further information, email bsmusales@bsigroup.com.

BSI Group Headquarters

389 Chiswick High Road London W4 4AL UK

Revisions

Our British Standards and other publications are updated by amendment or revision.

We continually improve the quality of our products and services to benefit your business. If you find an inaccuracy or ambiguity within a British Standard or other BSI publication please inform the Knowledge Centre.

Copyright

All the data, software and documentation set out in all British Standards and other BSI publications are the property of and copyrighted by BSI, or some person or entity that owns copyright in the information used (such as the international standardization bodies) and has formally licensed such information to BSI for commercial publication and use. Except as permitted under the Copyright, Designs and Patents Act 1988 no extract may be reproduced, stored in a retrieval system or transmitted in any form or by any means – electronic, photocopying, recording or otherwise – without prior written permission from BSI. Details and advice can be obtained from the Copyright & Licensing Department.

Useful Contacts:

Customer Services

Tel: +44 845 086 9001

Email (orders): orders@bsigroup.com

Email (enquiries): cservices@bsigroup.com

Subscriptions

Tel: +44 845 086 9001

Email: subscriptions@bsigroup.com

Knowledge Centre

Tel: +44 20 8996 7004

Email: knowledgecentre@bsigroup.com

Copyright & Licensing

Tel: +44 20 8996 7070

Email: copyright@bsigroup.com



...making excellence a habit.™