

BS EN ISO 9038:2013
BS 2000-602:2013



BSI Standards Publication

Determination of sustained combustibility of liquids (ISO 9038:2013)

bsi.

...making excellence a habit.™

National foreword

This British Standard is the UK implementation of EN ISO 9038:2013. It supersedes BS EN ISO 9038:2003 which is withdrawn.

The UK participation in its preparation was entrusted to Technical Committee PTI/13, Petroleum Testing and Terminology.

A list of organizations represented on this committee can be obtained on request to its secretary.

Energy Institute, under the brand of IP, publishes and sells all Parts of BS 2000, and all BS EN petroleum test methods that would be Part of BS 2000, both in its annual publication "Standard methods for analysis and testing of petroleum and related products and British Standard 2000 Parts" and individually.

Further information is available from:

Energy Institute, 61 New Cavendish Street, London, W1G 7AR.

Tel: 020 7467 7100. Fax: 020 7255 1472

This publication does not purport to include all the necessary provisions of a contract. Users are responsible for its correct application.

© The British Standards Institution 2013.
Published by BSI Standards Limited 2013

ISBN 978 0 580 66479 3
ICS 13.220.40; 87.040

Compliance with a British Standard cannot confer immunity from legal obligations.

This British Standard was published under the authority of the Standards Policy and Strategy Committee on 31 August 2013.

Amendments issued since publication

Date	Text affected
------	---------------

EUROPEAN STANDARD

EN ISO 9038

NORME EUROPÉENNE

EUROPÄISCHE NORM

July 2013

ICS 75.080

Supersedes EN ISO 9038:2003

English Version

Determination of sustained combustibility of liquids (ISO 9038:2013)

Détermination de la combustion entretenue des liquides
(ISO 9038:2013)

Bestimmung der Weiterbrennbarkeit von Flüssigkeiten (ISO 9038:2013)

This European Standard was approved by CEN on 12 July 2013.

CEN members are bound to comply with the CEN/CENELEC Internal Regulations which stipulate the conditions for giving this European Standard the status of a national standard without any alteration. Up-to-date lists and bibliographical references concerning such national standards may be obtained on application to the CEN-CENELEC Management Centre or to any CEN member.

This European Standard exists in three official versions (English, French, German). A version in any other language made by translation under the responsibility of a CEN member into its own language and notified to the CEN-CENELEC Management Centre has the same status as the official versions.

CEN members are the national standards bodies of Austria, Belgium, Bulgaria, Croatia, Cyprus, Czech Republic, Denmark, Estonia, Finland, Former Yugoslav Republic of Macedonia, France, Germany, Greece, Hungary, Iceland, Ireland, Italy, Latvia, Lithuania, Luxembourg, Malta, Netherlands, Norway, Poland, Portugal, Romania, Slovakia, Slovenia, Spain, Sweden, Switzerland, Turkey and United Kingdom.



EUROPEAN COMMITTEE FOR STANDARDIZATION
COMITÉ EUROPÉEN DE NORMALISATION
EUROPÄISCHES KOMITEE FÜR NORMUNG

Management Centre: Avenue Marnix 17, B-1000 Brussels

Foreword

This document (EN ISO 9038:2013) has been prepared by Technical Committee ISO/TC 28 "Petroleum products and lubricants" in collaboration with Technical Committee CEN/TC 139 "Paints and varnishes" the secretariat of which is held by DIN.

This European Standard shall be given the status of a national standard, either by publication of an identical text or by endorsement, at the latest by January 2014, and conflicting national standards shall be withdrawn at the latest by January 2014.

Attention is drawn to the possibility that some of the elements of this document may be the subject of patent rights. CEN [and/or CENELEC] shall not be held responsible for identifying any or all such patent rights.

This document supersedes EN ISO 9038:2003.

According to the CEN-CENELEC Internal Regulations, the national standards organizations of the following countries are bound to implement this European Standard: Austria, Belgium, Bulgaria, Croatia, Cyprus, Czech Republic, Denmark, Estonia, Finland, Former Yugoslav Republic of Macedonia, France, Germany, Greece, Hungary, Iceland, Ireland, Italy, Latvia, Lithuania, Luxembourg, Malta, Netherlands, Norway, Poland, Portugal, Romania, Slovakia, Slovenia, Spain, Sweden, Switzerland, Turkey and the United Kingdom.

Endorsement notice

The text of ISO 9038:2013 has been approved by CEN as EN ISO 9038:2013 without any modification.

Contents

	Page
Foreword	iv
Introduction	v
1 Scope	1
2 Normative references	1
3 Terms and definitions	1
4 Principle	2
5 Apparatus	2
6 Preparation of apparatus	3
7 Sampling	3
7.1 Paints, varnishes and related products.....	3
7.2 Petroleum and related products.....	3
8 Procedure	4
9 Assessment of results	5
10 Verification	5
11 Calculation of temperature adjustment	5
12 Precision	5
13 Test report	6
Annex A (normative) Combustibility tester	7
Annex B (normative) Apparatus verification	10
Bibliography	11

Foreword

ISO (the International Organization for Standardization) is a worldwide federation of national standards bodies (ISO member bodies). The work of preparing International Standards is normally carried out through ISO technical committees. Each member body interested in a subject for which a technical committee has been established has the right to be represented on that committee. International organizations, governmental and non-governmental, in liaison with ISO, also take part in the work. ISO collaborates closely with the International Electrotechnical Commission (IEC) on all matters of electrotechnical standardization.

The procedures used to develop this document and those intended for its further maintenance are described in the ISO/IEC Directives, Part 1. In particular the different approval criteria needed for the different types of ISO documents should be noted. This document was drafted in accordance with the editorial rules of the ISO/IEC Directives, Part 2. www.iso.org/directives

Attention is drawn to the possibility that some of the elements of this document may be the subject of patent rights. ISO shall not be held responsible for identifying any or all such patent rights. Details of any patent rights identified during the development of the document will be in the Introduction and/or on the ISO list of patent declarations received. www.iso.org/patents

Any trade name used in this document is information given for the convenience of users and does not constitute an endorsement.

The committee responsible for this document is ISO/TC 28, *Petroleum products and lubricants*, (WG 9) in conjunction with Technical Committee ISO/TC 35, *Paints and varnishes*.

This second edition cancels and replaces the first edition (ISO 9038:2002), which has been technically revised.

The main technical changes are the inclusion of 3 reference materials for verification in [Annex B](#).

Introduction

A product with a flash point within a given range can continue to burn after initial ignition, while a similar product, although it has a similar flash point, may not. This International Standard describes a method for discriminating between those products that sustain combustion and those that do not.

The method determines whether a flammable product, when maintained at a selected test temperature, gives off sufficient flammable vapour to cause ignition when an ignition source is applied, and continues to generate sufficient vapour to burn when the ignition source is removed.

This test method does not determine the flash point of the product under test but, by means of a pass/fail procedure, merely determines if it sustains combustion (fail) at a selected test temperature, as can be required to comply with laws or regulations relating to the storage, transport and use of flammable products. Before performing this test, it will normally be necessary to determine either the actual flash point of the material or the temperature range in which the flash point is located.

The apparatus specified in this International Standard enables a result to be determined by a rapid procedure using a small test portion (2 ml).

Determination of sustained combustibility of liquids

WARNING — The use of this International Standard may involve hazardous materials, operations or equipment. This International Standard does not purport to address all of the safety problems associated with its use. It is the responsibility of the user of this International Standard to establish appropriate safety and health practices and to determine the applicability of regulatory limitations prior to use.

1 Scope

This International Standard specifies a pass/fail procedure, at temperatures up to 100 °C, to determine whether or not a liquid product, that would be classified as “flammable” by virtue of its flash point, has the ability to sustain combustion at the temperature or temperatures specified in the appropriate regulations.

NOTE 1 Many national and international regulations classify liquids as presenting a flammable hazard on the basis of their flash point, as determined by a recognized method. Some of these regulations allow a derogation if the substance cannot “sustain combustion” at some specified temperature or temperatures.

NOTE 2 In connection with the United Nations recommendations on the Transport of Dangerous Goods as well as with the Globally Harmonized System of Classification and Labelling of Chemicals, and also with derived national/EC regulations, temperatures of 60,5 °C and 75,0 °C are specified for this test.^{[1][2]}

The procedure is applicable to paints (including water-borne paints), varnishes, paint binders, solvents, petroleum or related products and adhesives, which have a flash point. It is not applicable to painted surfaces in respect of assessing their potential fire hazards.

NOTE 3 This test method can be used, in addition to test methods for flash point, in assessing the fire hazard of a product.

NOTE 4 Particular care needs to be taken in translating results from this test method to large scale (real life) situations, as liquids in large quantities may not behave in the same way as small samples.

2 Normative references

The following documents, in whole or in part, are normatively referenced in this document and are indispensable for its application. For dated references, only the edition cited applies. For undated references, the latest edition of the referenced document (including any amendments) applies.

ISO 1513, *Paints and varnishes — Examination and preparation of test samples*

ISO 3170, *Petroleum liquids — Manual sampling*

ISO 3171, *Petroleum liquids — Automatic pipeline sampling*

ISO 15528, *Paints, varnishes and raw materials for paints and varnishes — Sampling*

3 Terms and definitions

For the purposes of this document, the following terms and definitions apply.

3.1

sustained combustibility

behaviour of a material, under specified test conditions, whereby its vapour can be ignited by an ignition source and, after ignition, sufficient flammable vapour is produced for burning to continue for at least 15 s after the source of ignition has been removed

3.2 flash point

lowest temperature, as measured in the prescribed manner, of a test portion, corrected to a barometric pressure of 101,3 kPa, at which application of an ignition source causes the vapour of the test portion to ignite momentarily and the flame to propagate across the surface of the liquid, under the specified conditions of test

4 Principle

A test portion of specified volume is introduced into the test cup, which is maintained at the test temperature. After a specified time an ignition source is applied.

The ability of the product to sustain combustion is assessed on the basis of its ability to ignite, when exposed to an ignition source, and whether it continues to burn after the ignition source has been removed.

5 Apparatus

5.1 Combustibility tester, as specified in [Annex A](#).

5.2 Electrical heater, attached to the bottom of the test cup in a manner that provides efficient transfer of heat. The heater control shall be capable of maintaining the test cup temperature, as measured on the temperature measuring device, and in a draught-free area, within $\pm 0,5$ °C for test temperatures up to and including 100 °C.

NOTE The combustibility tester, heater and heater control unit can consist of an integrated apparatus.

5.3 Gauge, for checking that the height of the centre of the gas jet above the top of the test cup is $2,2 \text{ mm} \pm 0,1 \text{ mm}$. A calibrated metal strip is suitable.

5.4 Temperature measuring device.

5.4.1 This shall be suitable for horizontal operation, and of suitable range and dimensions.

5.4.2 Resolution to be able to be read to the nearest 0,5 °C.

5.4.3 Accuracy $\pm 0,5$ °C.

5.4.4 When in position in the block, the temperature measuring device shall be surrounded with heat transfer paste to ensure good heat transfer between the block and the measuring device.

NOTE It is recommended that the accuracy of the temperature measuring device be checked at least every 12 months or when indicated by a user verification check schedule.

5.5 Stopwatch or other suitable timing device, capable of measuring $15 \text{ s} \pm 1 \text{ s}$, $30 \text{ s} \pm 1 \text{ s}$ and $60 \text{ s} \pm 2 \text{ s}$. The timing device can be fitted with a means of producing an audible signal.

5.6 Syringe or pipette, capable of delivering 2,00 ml to an accuracy of $\pm 0,05 \text{ ml}$.

5.7 Ignition source and gas supply. The ignition source can be fuelled by natural gas, coal gas, butane or any other gas found to be suitable. The fuel supply to the gas jet shall be fitted with a suitable regulator, or other means of regulating the gas flow, such that the width of the flame can be adjusted to $4,0 \text{ mm} \pm 0,5 \text{ mm}$.

5.8 Draught shield, to minimize draughts, fitted at the back and two sides of the instrument. A shield 350 mm high, 480 mm wide and 240 mm deep is suitable.

5.9 Barometer, measuring absolute pressure, with an accuracy of 0,5 kPa. Do not use aneroid barometers pre-corrected to give sea level readings, such as those used at weather stations and airports.

6 Preparation of apparatus

- 6.1** Do not carry out the test in a small confined area because of the risk of explosion.
- 6.2** Thoroughly clean and dry the test cup and assembly before use, taking care not to damage the surface of the test cup.
- 6.3** Position the combustibility tester on a level, stable surface and away from strong light (to facilitate observation of a flash or flame). Ensure that the top of the metal block is horizontal.
- 6.4** Use the gauge (5.3) to check that the jet is $2,2 \text{ mm} \pm 0,1 \text{ mm}$ above the top of the block (see [Figure A.2](#)).
- 6.5** It is essential that the apparatus is set up in a draught free area (see Notes 1 and 2). It can be necessary to surround the tester on three sides with a draught shield (5.8) for protection. If a fume hood is used, minimize the exhaust draught.

NOTE 1 The air speed within 50 mm of the top of the test cup should preferably be less than 0,05 m/s.

NOTE 2 Because the combustibility tester has an open test cup, the apparatus should always be used with a draught shield in place.

7 Sampling

7.1 Paints, varnishes and related products

Take a representative sample of the product to be tested, as described in ISO 15528, and examine and prepare it for testing, as described in ISO 1513.

7.2 Petroleum and related products

7.2.1 Sampling procedure

Take a representative sample of the product to be tested, as described in ISO 3170 or ISO 3171, as appropriate. The container shall be made of a material appropriate to the product being sampled and be filled to between 85 % and 95 % of its capacity.

7.2.2 Sample handling

7.2.2.1 Obtain a representative sample of at least 50 ml and store in a clean, tightly closed container in a cool place to minimize vapour loss or pressure build-up.

7.2.2.2 The sample shall receive only the minimum treatment to ensure homogeneity, to minimize the possible loss of volatile constituents. After removing each test portion, immediately close the sample container tightly to ensure that no volatile components escape from the container. If this closure is not secure, obtain a new sample.

7.2.2.3 Ensure that the sample is at least 10 °C below the selected test temperature before opening to remove the test portion. For mobile materials, mix the sample by gentle shaking. For viscous samples, if necessary heat the sample in its container to a temperature such that the sample can be mixed by gentle shaking or to at least 10 °C below the selected test temperature, whichever is lower. Ensure that high pressures do not develop in the container.

8 Procedure

8.1 Record the absolute barometric pressure of the laboratory at the time of the test.

NOTE It is not considered necessary to correct the barometric pressure reading from ambient temperature to 0 °C, although some barometers automatically make this correction.

8.2 Inspect the test cup for cleanliness and freedom from contamination. Use an absorbent paper tissue to wipe clean, if necessary.

8.3 If the sustained-combustibility test is to be carried out at a temperature specified in regulations or specifications, calculate the adjusted temperature using the specification temperature by correcting for the effect of atmospheric pressure (see [Clause 11](#)). Use this adjusted temperature for the test.

8.4 Set the heater control so that the combustibility tester is at the required and stable temperature.

8.5 Open the gas control valve and ignite the ignition source with the jet away from the test position (i.e. in the “off” position, away from the test cup). Adjust the ignition source using the flow control valve so that its width conforms to the size of the flame gauge ring.

8.6 Charge a clean and dry syringe or pipette with a $2,0 \text{ ml} \pm 0,1 \text{ ml}$ test portion of the sample and completely discharge this test portion into the test cup. Immediately start the timing device ([5.5](#)). Take care not to lose any sample.

8.7 The operator shall take appropriate safety precautions during the transfer of the test portion to the test cup and the initial application of the ignition source to the test portion. Samples containing low flash point material can give a violent ignition.

8.8 After a heating time of $60 \text{ s} \pm 2 \text{ s}$, by which time the test portion is deemed to have reached its equilibrium temperature, and if the test portion has not ignited, carefully move the ignition source into the test position over the edge of the test cup. Maintain it in this position for $15 \text{ s} \pm 1 \text{ s}$ and then return it to the “off” position while observing the behaviour of the test portion. The ignition source shall remain alight throughout the test.

8.9 Turn off the pilot flame and ignition source using the gas control valve, and if necessary the power to the heater. When the temperature of the metal block of the combustibility tester reaches a safe level, remove the used test portion and clean the instrument.

Carry out the determination in duplicate, using a new test portion for each test. If duplicate determinations do not give the same result, carry out an additional single determination; this determination is the result.

For each determination observe and record:

- a) whether or not there is ignition and sustained burning or flashing of the test portion before the ignition source is moved into the test position.
- b) whether the test portion ignites while the ignition source is in the test position and, if so, how long combustion is sustained after the ignition source is returned to the “off” position.

NOTE If combustion is sustained beyond 20 s, it is permissible to extinguish the flame safely rather than wait for the flame to extinguish itself naturally.

8.10 If the result is that sustained combustion is not found, repeat the procedure with new test portions but with a heating time of $30 \text{ s} \pm 1 \text{ s}$.

NOTE For materials containing low concentrations of volatile combustible compounds a 30 s heating time will minimize the loss of these volatile compounds.

9 Assessment of results

Assess the product either as not sustaining combustion (pass) or as sustaining combustion (fail). Report sustained combustion at either of the heating times if one of the following has occurred:

- a) when the ignition source is in the “off” position, the test portion ignites.
- b) the test portion ignites while the ignition source is in the “test” position, maintained for 15 s, and continues to burn for more than 15 s after the ignition source has been returned to the “off” position.

Intermittent combustion, for less than 15 s, shall not be interpreted as sustained combustion. Normally, at the end of 15 s the combustion has either clearly ceased or continues. In cases of doubt, the product shall be deemed to sustain combustion and hence to fail.

10 Verification

Verify the correct functioning of the apparatus in accordance with [Annex B](#).

11 Calculation of temperature adjustment

If the absolute barometric pressure reading taken in [Clause 8](#) is in a unit other than kilopascals, convert the reading to kilopascals using the following:

Reading in hPa $\times 0,1 = \text{kPa}$

Reading in mbar $\times 0,1 = \text{kPa}$

Reading in mmHg $\times 0,133\ 322 = \text{kPa}$

Correct the specified test temperature (for example 60,0 °C or 75,0 °C) as follows:

$$t_a = t_s - 0,25(101,3 - p)$$

where

t_a is the adjusted test temperature in degrees Celsius;

t_s is the specified test temperature in degrees Celsius at 101,3 kPa;

p is the ambient barometric pressure, in kilopascals;

0,25 is a constant with dimensions degrees Celsius per kilopascal;

101,3 is the standard pressure in kilopascals.

NOTE 1 For all practical purposes, a 4 kPa change in atmospheric pressure is equivalent to a 1,0 °C change in the test temperature. The temperature correction is positive for pressures above 101,3 kPa, and negative for pressures below 101,3 kPa.

NOTE 2 The above equation has been proven for barometric pressures down to 82,0 kPa and is strictly correct only up to 104,7 kPa. Atmospheric pressures corrections at pressures down to 82,0 kPa have been shown to be valid in an ISO 3679 study.^[3]

12 Precision

Precision data are not yet available.

13 Test report

The test report shall contain at least the following information:

- a) all details necessary for complete identification of the product tested;
- b) a reference to this International Standard (ISO 9038:2013);
- c) any deviation, by agreement or otherwise, from the test procedure specified;
- d) the ambient atmospheric pressure;
- e) the temperature of the final result at which the test was carried out, corrected for barometric pressure;
- f) whether or not the product sustained combustion and, if combustion was sustained, the heating time (30 s or 60 s);
- g) the date of the test.

Annex A (normative)

Combustibility tester

A combustibility tester consists of a block of aluminium alloy or other corrosion-resistant metal of high thermal conductivity (see [Figure A.1](#)). The block has a concave depression (test cup) and a well drilled to take a temperature measuring device (5.4). A small gas jet assembly on a swivel is attached to the block. The handle and gas inlet for the gas jet can be fitted at any convenient angle to the gas jet. The height of the centre of the gas jet above the top of the test cup is $2,2 \text{ mm} \pm 0,1 \text{ mm}$ (see [Figure A.2](#)). A gauge ring $4,0 \text{ mm} \pm 0,5 \text{ mm}$ in diameter shall be engraved on top of the tester near the ignition source (5.7) when it is in the “off” position. The dimensions of the block and test cup assembly are given in [Table A.1](#) and the dimensions of the gas jet assembly are given in [Table A.2](#). The sensing element of the temperature measuring device shall be located centrally under the test cup as shown in [Figure A.1](#).

Table A.1 — Dimensions of block and test cup assembly (see [Figure A.1](#))

Property	Dimension
Diameter of block mm	61,0 to 62,5
Height of block mm	35,0 to 36,0
Diameter of flange mm	approx. 95,0
Thickness of flange mm	approx. 3,0
Height of test cup lip above flange mm	0,6 to 1,0
Outside diameter of test cup lip mm	approx. 41,0
Spherical radius of test cup mm	33,0 to 33,5
Depth of test cup mm	6,2 to 6,4
Distance from top of block to temperature measuring device well (centre) mm	16,0 to 17,0
Diameter of flame gauge ring mm	$4,0 \pm 0,5$
Diameter of temperature measuring device well mm	approx. 7,0 ^a
Angle subtended by jet from stop (“off” position) to “test” position	45°
a The diameter of the temperature measuring device well can be reduced to fit the device used.	

Table A.2 — Dimensions of gas jet assembly (see [Figure A.2](#))

Property	Dimension
Outside diameter of jet mm	3,0 to 4,0
Jet end taper to mm	1,7 to 2,3
Bore of jet mm	0,6 to 0,8
Length of jet from centre of pivot to tip mm	36,0 to 36,2
Distance of axis of pivot from centre of test cup mm	38,0 to 38,2
Height of centreline of jet above top of test cup lip mm	$2,2 \pm 0,1$

Dimension in millimetres

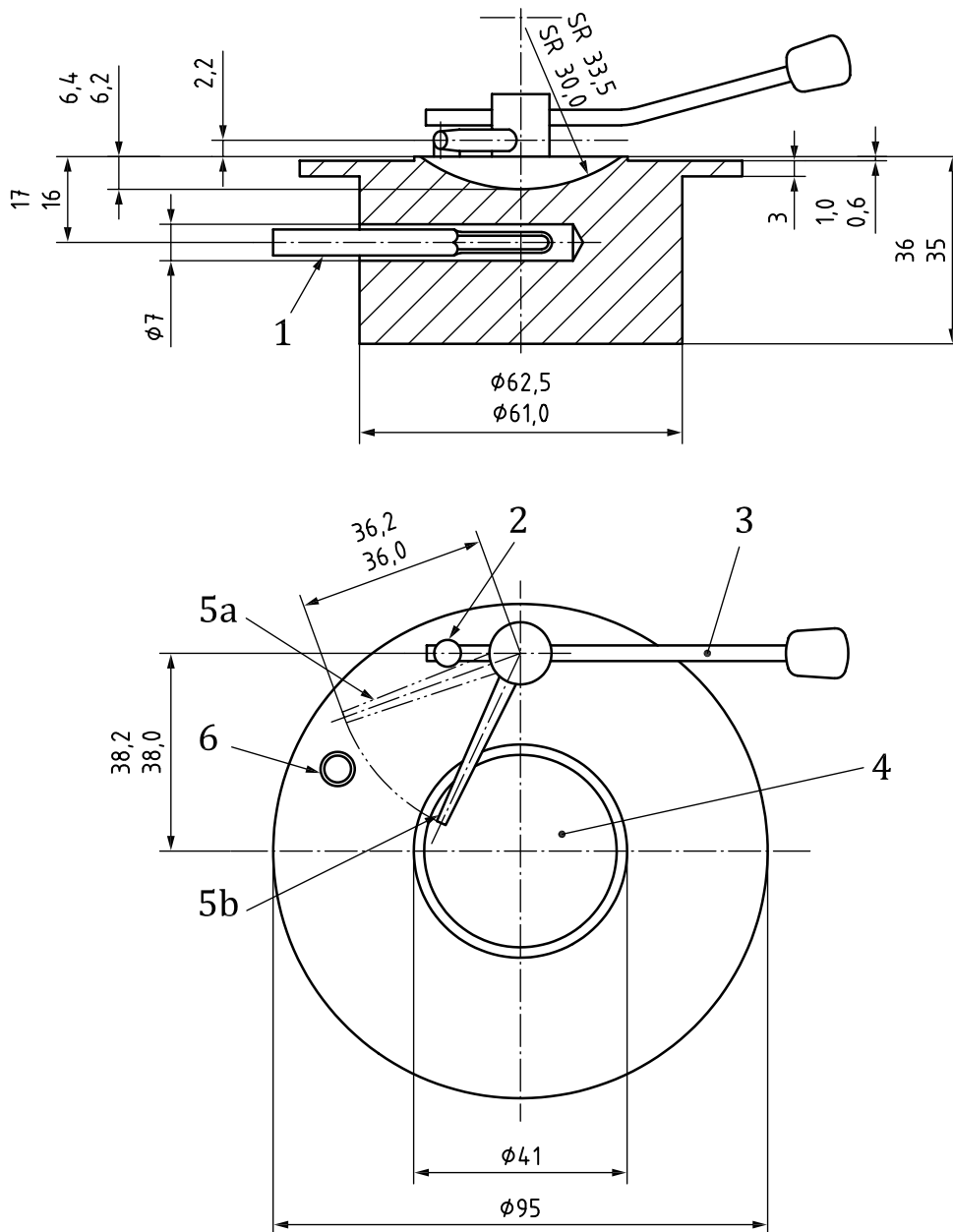

Key

- 1 Temperature measuring device
- 2 Stop
- 3 Handle
- 4 Test cup
- 5a Ignition source in "off" position
- 5b Ignition source in "test" position
- 6 Gauge ring

Figure A.1 — Block and test cup assembly

Dimension in millimetres

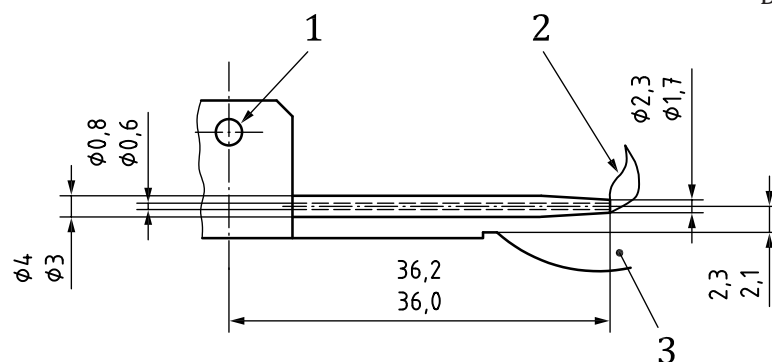

Key

- 1 Gas inlet
- 2 Ignition source
- 3 Test cup

Figure A.2 — Gas jet assembly

Annex B (normative)

Apparatus verification

B.1 General

This verification procedure shall be used to check the performance of the apparatus. Apparatus shall be checked at least every 12 months or as indicated by a user verification check schedule.

B.2 Reference materials

B.2.1 n-Decane, purity > 99 % (mass fraction).

B.2.2 n-Undecane, purity > 99 % (mass fraction).

B.2.3 n-Dodecane, purity > 99 % (mass fraction).

Table B.1 — Results for verification of the apparatus

Reference material	Test temperature	
	60 °C (adjusted; see Clause 11)	75 °C (adjusted; see Clause 11)
n-Decane	fail	fail
n-Undecane	pass	fail
n-Dodecane	pass	pass

The pass fail criteria were obtained from an interlaboratory study^[4]

B.3 Procedure

Use only a 60 s heating time to verify the performance of the apparatus. Use the procedure given in [Clauses 6, 7 and 8](#) with all three reference materials listed in Clause B.2. Use test temperatures of 60,0 °C and 75,0 °C.

B.4 Expression of results

Verification will be confirmed if the results presented in [Table B.1](#) are reproduced, where:

- “fail” denotes the test portion supports combustion by the criteria described in Clause 9;
- “pass” denotes that the test portion does not support combustion by the criteria described in Clause 9.

If the results given by the test apparatus meet the required verification performance, record this fact in a permanent record.

If the results given by the test apparatus do not meet the required verification performance, check that the immediate environment of the test cup is free of draughts, and that adequate heat-transfer paste surrounds the temperature measuring device.

If the apparatus continues to give results which do not meet the required responses in [Table B.1](#), recheck the apparatus for conformity with the apparatus specification and the purity of the reference material. If no obvious nonconformity can be identified, contact the manufacturer.

Bibliography

- [1] GLOBALLY HARMONIZED SYSTEM OF CLASSIFICATION AND LABELLING OF CHEMICALS (GHS), Fourth revised edition, UNITED NATIONS, New York and Geneva, CH
- [2] Recommendations on the Transport of Dangerous Goods, Model Regulations 17. Revised edition, UNITED NATIONS, New York and Geneva, CH
- [3] Research Report Round Robin/Interlaboratory Study ISO 3679 Determination of flash point – rapid equilibrium closed cup apparatus. Energy Institute, 61 New Cavendish Street, London. W1G 7AR. UK
- [4] Report on the round robin tests on sustained combustibility according to ISO 9038, Physikalisch-Technische Bundesanstalt (PTB), Bundesallee 100, D-38116 Braunschweig, Germany

Buying Parts of BS 2000

Orders for BS 2000 publications should be addressed to either:

Energy Institute – Library and Information Service

61 New Cavendish Street
London
W1G 7AR

Tel: +44 (0)20 7467 7100

Fax: +44 (0)20 7255 1472

www.energyinst.org.uk

Order standards securely via:

www.energyinstpubs.org.uk

or:

British Standards Institution – Customer Services

389 Chiswick High Road
London
W4 4AL

Tel: +44 (0)20 8996 9001

Fax: +44 (0)20 8996 7001

www.bsi-global.com

Order hard copy standards securely via:

www.bsi-global.com/bsonline

Copyright

Copyright exists in all BS 2000 publications. No part of this publication may be reproduced in any form without the prior permission in writing of BSI and the Energy Institute. Enquiries about copyright should be made to the Secretary of PTI/13 at the Energy Institute.



British Standards Institution (BSI)

BSI is the national body responsible for preparing British Standards and other standards-related publications, information and services.

BSI is incorporated by Royal Charter. British Standards and other standardization products are published by BSI Standards Limited.

About us

We bring together business, industry, government, consumers, innovators and others to shape their combined experience and expertise into standards-based solutions.

The knowledge embodied in our standards has been carefully assembled in a dependable format and refined through our open consultation process. Organizations of all sizes and across all sectors choose standards to help them achieve their goals.

Information on standards

We can provide you with the knowledge that your organization needs to succeed. Find out more about British Standards by visiting our website at bsigroup.com/standards or contacting our Customer Services team or Knowledge Centre.

Buying standards

You can buy and download PDF versions of BSI publications, including British and adopted European and international standards, through our website at bsigroup.com/shop, where hard copies can also be purchased.

If you need international and foreign standards from other Standards Development Organizations, hard copies can be ordered from our Customer Services team.

Subscriptions

Our range of subscription services are designed to make using standards easier for you. For further information on our subscription products go to bsigroup.com/subscriptions.

With **British Standards Online (BSOL)** you'll have instant access to over 55,000 British and adopted European and international standards from your desktop. It's available 24/7 and is refreshed daily so you'll always be up to date.

You can keep in touch with standards developments and receive substantial discounts on the purchase price of standards, both in single copy and subscription format, by becoming a **BSI Subscribing Member**.

PLUS is an updating service exclusive to BSI Subscribing Members. You will automatically receive the latest hard copy of your standards when they're revised or replaced.

To find out more about becoming a BSI Subscribing Member and the benefits of membership, please visit bsigroup.com/shop.

With a **Multi-User Network Licence (MUNL)** you are able to host standards publications on your intranet. Licences can cover as few or as many users as you wish. With updates supplied as soon as they're available, you can be sure your documentation is current. For further information, email bsmusales@bsigroup.com.

BSI Group Headquarters

389 Chiswick High Road London W4 4AL UK

Revisions

Our British Standards and other publications are updated by amendment or revision.

We continually improve the quality of our products and services to benefit your business. If you find an inaccuracy or ambiguity within a British Standard or other BSI publication please inform the Knowledge Centre.

Copyright

All the data, software and documentation set out in all British Standards and other BSI publications are the property of and copyrighted by BSI, or some person or entity that owns copyright in the information used (such as the international standardization bodies) and has formally licensed such information to BSI for commercial publication and use. Except as permitted under the Copyright, Designs and Patents Act 1988 no extract may be reproduced, stored in a retrieval system or transmitted in any form or by any means – electronic, photocopying, recording or otherwise – without prior written permission from BSI. Details and advice can be obtained from the Copyright & Licensing Department.

Useful Contacts:

Customer Services

Tel: +44 845 086 9001

Email (orders): orders@bsigroup.com

Email (enquiries): cservices@bsigroup.com

Subscriptions

Tel: +44 845 086 9001

Email: subscriptions@bsigroup.com

Knowledge Centre

Tel: +44 20 8996 7004

Email: knowledgecentre@bsigroup.com

Copyright & Licensing

Tel: +44 20 8996 7070

Email: copyright@bsigroup.com



...making excellence a habit.™