

Ergonomics of the thermal environment — Determination of metabolic rate

The European Standard EN ISO 8996:2004 has the status of a
British Standard

ICS 13.180

National foreword

This British Standard is the official English language version of EN ISO 8996:2004. It is identical with ISO 8996:2004. It supersedes BS EN 28996:1994 which is withdrawn.

The UK participation in its preparation was entrusted by Technical Committee PH/9, Applied ergonomics, to Subcommittee PH/9/1, Thermal environments, which has the responsibility to:

- aid enquirers to understand the text;
- present to the responsible international/European committee any enquiries on the interpretation, or proposals for change, and keep the UK interests informed;
- monitor related international and European developments and promulgate them in the UK.

A list of organizations represented on this subcommittee can be obtained on request to its secretary.

Cross-references

The British Standards which implement international or European publications referred to in this document may be found in the *BSI Catalogue* under the section entitled “International Standards Correspondence Index”, or by using the “Search” facility of the *BSI Electronic Catalogue* or of British Standards Online.

This publication does not purport to include all the necessary provisions of a contract. Users are responsible for its correct application.

Compliance with a British Standard does not of itself confer immunity from legal obligations.

Summary of pages

This document comprises a front cover, an inside front cover, the EN ISO title page, the EN ISO foreword page, the ISO title page, pages ii to iv, pages 1 to 24, an inside back cover and a back cover.

The BSI copyright notice displayed in this document indicates when the document was last issued.

Amendments issued since publication

Amd. No.	Date	Comments

English version

Ergonomics of the thermal environment - Determination of metabolic rate (ISO 8996:2004)

Ergonomie de l'environnement thermique - Détermination du métabolisme énergétique (ISO 8996:2004)

Ergonomie der thermischen Umgebung - Bestimmung des körpereigenen Energieumsatzes (ISO 8996:2004)

This European Standard was approved by CEN on 26 August 2004.

CEN members are bound to comply with the CEN/CENELEC Internal Regulations which stipulate the conditions for giving this European Standard the status of a national standard without any alteration. Up-to-date lists and bibliographical references concerning such national standards may be obtained on application to the Central Secretariat or to any CEN member.

This European Standard exists in three official versions (English, French, German). A version in any other language made by translation under the responsibility of a CEN member into its own language and notified to the Central Secretariat has the same status as the official versions.

CEN members are the national standards bodies of Austria, Belgium, Cyprus, Czech Republic, Denmark, Estonia, Finland, France, Germany, Greece, Hungary, Iceland, Ireland, Italy, Latvia, Lithuania, Luxembourg, Malta, Netherlands, Norway, Poland, Portugal, Slovakia, Slovenia, Spain, Sweden, Switzerland and United Kingdom.



EUROPEAN COMMITTEE FOR STANDARDIZATION
COMITÉ EUROPÉEN DE NORMALISATION
EUROPÄISCHES KOMITEE FÜR NORMUNG

Management Centre: rue de Stassart, 36 B-1050 Brussels

Foreword

This document (EN ISO 8996:2004) has been prepared by Technical Committee ISO/TC 159 "Ergonomics" in collaboration with Technical Committee CEN/TC 122 "Ergonomics", the secretariat of which is held by DIN.

This European Standard shall be given the status of a national standard, either by publication of an identical text or by endorsement, at the latest by April 2005, and conflicting national standards shall be withdrawn at the latest by April 2005.

This document supersedes EN 28996:1993.

According to the CEN/CENELEC Internal Regulations, the national standards organizations of the following countries are bound to implement this European Standard: Austria, Belgium, Cyprus, Czech Republic, Denmark, Estonia, Finland, France, Germany, Greece, Hungary, Iceland, Ireland, Italy, Latvia, Lithuania, Luxembourg, Malta, Netherlands, Norway, Poland, Portugal, Slovakia, Slovenia, Spain, Sweden, Switzerland and United Kingdom.

Endorsement notice

The text of ISO 8996:2004 has been approved by CEN as EN ISO 8996:2004 without any modifications.

INTERNATIONAL
STANDARD

ISO
8996

Second edition
2004-10-01

**Ergonomics of the thermal
environment — Determination of
metabolic rate**

*Ergonomie de l'environnement thermique — Détermination du
métabolisme énergétique*



Reference number
ISO 8996:2004(E)

Contents	Page
Foreword	iv
1 Scope	1
2 Normative references	1
3 Principle and accuracy	1
4 Level 1, screening	3
4.1 Table for the estimation of metabolic rate by occupation	3
4.2 Classification of metabolic rate by categories	3
5 Level 2, observation	3
5.1 Estimation of metabolic rate by task requirements	3
5.2 Metabolic rate for typical activities	4
5.3 Metabolic rate for a work cycle	4
5.4 Influence of the length of rest periods and work periods	5
5.5 Obtaining values by interpolation	6
5.6 Requirements for the application of metabolic-rate tables	6
6 Level 3, analysis	6
6.1 Estimation of metabolic rate using heart rate	6
6.2 Relationship between heart rate and metabolic rate	7
7 Level 4, expertise	8
7.1 Determination of metabolic rate by measurement of oxygen consumption rate	8
7.2 The doubly labelled water method for long-term measurements	14
7.3 Direct calorimetry — Principle	14
Annex A (informative) Evaluation of the metabolic rate at level 1, screening	15
Annex B (informative) Evaluation of the metabolic rate at level 2, observation	17
Annex C (informative) Evaluation of the metabolic rate at level 3, analysis	20
Annex D (informative) Evaluation of the metabolic rate at level 4, expertise — Examples of the calculation of metabolic rate based on measured data	21

Foreword

ISO (the International Organization for Standardization) is a worldwide federation of national standards bodies (ISO member bodies). The work of preparing International Standards is normally carried out through ISO technical committees. Each member body interested in a subject for which a technical committee has been established has the right to be represented on that committee. International organizations, governmental and non-governmental, in liaison with ISO, also take part in the work. ISO collaborates closely with the International Electrotechnical Commission (IEC) on all matters of electrotechnical standardization.

International Standards are drafted in accordance with the rules given in the ISO/IEC Directives, Part 2.

The main task of technical committees is to prepare International Standards. Draft International Standards adopted by the technical committees are circulated to the member bodies for voting. Publication as an International Standard requires approval by at least 75 % of the member bodies casting a vote.

Attention is drawn to the possibility that some of the elements of this document may be the subject of patent rights. ISO shall not be held responsible for identifying any or all such patent rights.

ISO 8996 was prepared by Technical Committee ISO/TC 159, *Ergonomics*, Subcommittee SC 5, *Ergonomics of the physical environment*.

This second edition cancels and replaces the first edition (ISO 8996:1990), which has been technically revised.

Ergonomics of the thermal environment — Determination of metabolic rate

1 Scope

The metabolic rate, as a conversion of chemical into mechanical and thermal energy, measures the energetic cost of muscular load and gives a numerical index of activity. Metabolic rate is an important determinant of the comfort or the strain resulting from exposure to a thermal environment. In particular, in hot climates, the high levels of metabolic heat production associated with muscular work aggravate heat stress, as large amounts of heat need to be dissipated, mostly by sweat evaporation.

This International Standard specifies different methods for the determination of metabolic rate in the context of ergonomics of the climatic working environment. It can also be used for other applications — for example, the assessment of working practices, the energetic cost of specific jobs or sport activities, the total cost of an activity, etc.

The estimations, tables and other data included in this International Standard concern an “average” individual:

- a man 30 years old weighing 70 kg and 1,75 m tall (body surface area 1,8 m²);
- a woman 30 years old weighing 60 kg and 1,70 m tall (body surface area 1,6 m²).

Users should make appropriate corrections when they are dealing with special populations including children, aged persons, people with physical disabilities, etc.

2 Normative references

The following referenced documents are indispensable for the application of this document. For dated references, only the edition cited applies. For undated references, the latest edition of the referenced document (including any amendments) applies.

ISO 9886, *Ergonomics — Evaluation of thermal strain by physiological measurements*

ISO 15265, *Ergonomics of the thermal environment — Risk assessment strategy for the prevention of stress or discomfort in thermal working conditions*

3 Principle and accuracy

The mechanical efficiency of muscular work — called the “useful work”, W — is low. In most types of industrial work, it is so small (a few percent) that it is assumed to be nil. This means that the total energy consumption while working is assumed equal to the heat production. For the purposes of this International Standard, the metabolic rate is assumed to be equal to the rate of heat production.

Table 1 lists the different approaches presented in this International Standard for determining the metabolic rate.

These approaches are structured following the philosophy exposed in ISO 15265 regarding the assessment of exposure. Four levels are considered here:

Level 1, screening: Two methods simple and easy to use are presented to quickly characterize the mean workload for a given occupation or for a given activity:

- method 1A is a classification according to occupation;
- method 1B is a classification according to the kind of activity.

Both methods provide only a rough estimate and there is considerable scope for error. This limits their accuracy considerably. At this level, an inspection of the work place is not necessary.

Level 2, observation: Two methods are presented for people with full knowledge of the working conditions but without necessarily a training in ergonomics, to characterize, on average, a working situation at a specific time:

- in method 2A, the metabolic rate is determined by adding to the baseline metabolic rate the metabolic rate for body posture, the metabolic rate for the type of work and the metabolic rate for body motion related to work speed (using group assessment tables);
- in method 2B, the metabolic rate is determined by means of the tabulated values for various activities.

A procedure is described to record the activities with time and compute the time-weighted average metabolic rate, using the data from the two methods above.

The possibility for errors is high. A time and motion study is necessary to determine the metabolic rate in work situations that involve a cycle of different activities.

Level 3, analysis: One method is addressed to people trained in occupational health and ergonomics of the thermal environment. The metabolic rate is determined from heart rate recordings over a representative period. This method for the indirect determination of metabolic rate is based on the relationship between oxygen uptake and heart rate under defined conditions.

Level 4, expertise: Three methods are presented. They require very specific measurements made by experts:

- in Method 4A, the oxygen consumption is measured over short periods (10 min to 20 min) (a detailed time and motion study is necessary to show the representativity of the measurement period);
- method 4B is the so-called doubly labelled water method aiming at characterizing the average metabolic rate over much longer periods (1 to 2 weeks);
- method 4C is a direct calorimetry method.

The main factors affecting the accuracy of the estimations are the following:

- individual variability;
- differences in the work equipment;
- differences in work speed;
- differences in work technique and skill;
- gender differences and anthropometric characteristics;
- cultural differences;
- when using the tables, differences between observers and their level of training;

- when using level 3, the accuracy of the relationship between heart rate and oxygen uptake, as other stress factors also influence the heart rate;
- at level 4, the measurement accuracy (determination of gas volume and oxygen fraction).

The accuracy of the results, but also the costs of the study, increase from level 1 to level 4. Measurement at level 4 gives the most accurate values. As far as possible, the most accurate method should be used.

Table 1 — Levels for the determination of the metabolic rate

Level	Method	Accuracy	Inspection of the work place
1 Screening	1A: Classification according to occupation	Rough information	Not necessary, but information needed on technical equipment, work organization
	1B: Classification according to activity	Very great risk of error	
2 Observation	2A: Group assessment tables	High error risk	Time and motion study necessary
	2B: Tables for specific activities	Accuracy: ± 20 %	
3 Analysis	Heart rate measurement under defined conditions	Medium error risk Accuracy: ± 10 %	Study required to determine a representative period
4 Expertise	4A: Measurement of oxygen consumption	Errors within the limits of the accuracy of the measurement or of the time and motion study	Time and motion study necessary
	4B: Doubly labelled water method		Inspection of work place not necessary, but leisure activities must be evaluated.
	4C: Direct calorimetry	Accuracy: ± 5 %	Inspection of work place not necessary

4 Level 1, screening

4.1 Table for the estimation of metabolic rate by occupation

Table A.1 in Annex A shows the metabolic rate for different occupations. The values are mean values for the whole working time, but without considering longer rest pauses, for example lunchtime. Significant variation may arise due to differences in technology, work elements, work organization, etc.

4.2 Classification of metabolic rate by categories

The metabolic rate can be estimated approximately using the classification given in Annex A. Table A.2 defines five classes of metabolic rate: resting, low, moderate, high, very high. For each class, an average and a range of metabolic rate values are given as well as a number of examples. These activities are supposed to include short rest pauses. The examples given in Table A.2 illustrate the classification.

5 Level 2, observation

5.1 Estimation of metabolic rate by task requirements

Here, the metabolic rate is estimated from the following observations:

- the body segment involved in the work: both hands, one arm, two arms, the entire body;

- the workload for that body segment: light, medium, heavy, as judged subjectively by the observer;
- the body posture: sitting, kneeling, crouching, standing, standing stooped;
- the work speed.

Table B.1 in Annex B gives the mean value and the range of metabolic rates for a standard person, seated, as a function of the body segment involved and the workload. Table B.2 gives the corrections to be added when the posture is different from seated.

5.2 Metabolic rate for typical activities

Table B.3 in Annex B provides values of metabolic rate for typical activities. These values are based on measurements performed in the past in many different laboratories.

5.3 Metabolic rate for a work cycle

To determine the overall metabolic rate for a work cycle, it is necessary to carry out a time and motion study that includes a detailed description of the work. This involves classifying each activity and taking account of factors such as the duration of each activity, the distances walked, the heights climbed, the weights manipulated, the number of actions carried out, etc.

The time-weighted average metabolic rate for a work cycle can be determined from the metabolic rate of the respective activity and the respective duration using the equation:

$$M = \frac{1}{T} \sum_{i=1}^n M_i t_i \quad (1)$$

where

M is the average metabolic rate for the work cycle, in watts per square metre;

M_i is the metabolic rate for activity i , in watts per square metre;

t_i is the duration of activity i , in minutes;

T is the duration, in minutes, of the work cycle considered, and is equal to the sum of the partial durations t_i .

The recording of occupational activities and the duration of the activities for a working day or for a particular period may be simplified by using the diary described in Table B.4 and Table B.5. Activities are recorded when they are changed, using a classification code derived from the tables for the estimation of metabolic rate by task components. The number of components to be considered will vary depending upon the complexity of the activity.

The procedure is as follows:

- a) Fill in the name and other details of the person under study.
- b) Observe the work of the person under study (at least 2 h to 3 h).
- c) Determine each individual task component and the corresponding metabolic rate estimated from Table B.1, B.2 or B.3.
- d) Always fill in the diary when the task component is changed.
- e) Calculate the total length of time spent on each task component.

- f) Multiply the length of time spent on each task component by the corresponding metabolic rate.
- g) Add the values.
- h) Divide the sum by the total length of the observation period.

Forms for the evaluation are given in Tables B.4 and B.5.

5.4 Influence of the length of rest periods and work periods

The tables in Annex B cannot be used for the evaluation of the average metabolic rate for working conditions with an intermittent sequence of short periods of activity and long rest periods. In this case, the technique described in 5.3. would lead to an underestimation of the metabolic rate, known as the Simonson effect. The limit of validity of combinations of work and rest periods is shown by the curve in Figure 1. Example 1 concerns a cycle of 8 min of rest and 1 min of work. In this case, the technique described in 5.3 would lead to an underestimation of the metabolic rate and the tables in Annex B cannot be used. For work-rest cycles such as in Example 2, the tables can be used with the indicated accuracy.

Figure 1 only applies if there is no physical workload during the rest periods.

An increase in the metabolic rate due to this effect depends on the type of work and the muscle groups used. Further information on this problem is not given here, because of its complexity and because of its low relevancy at this level of evaluation.

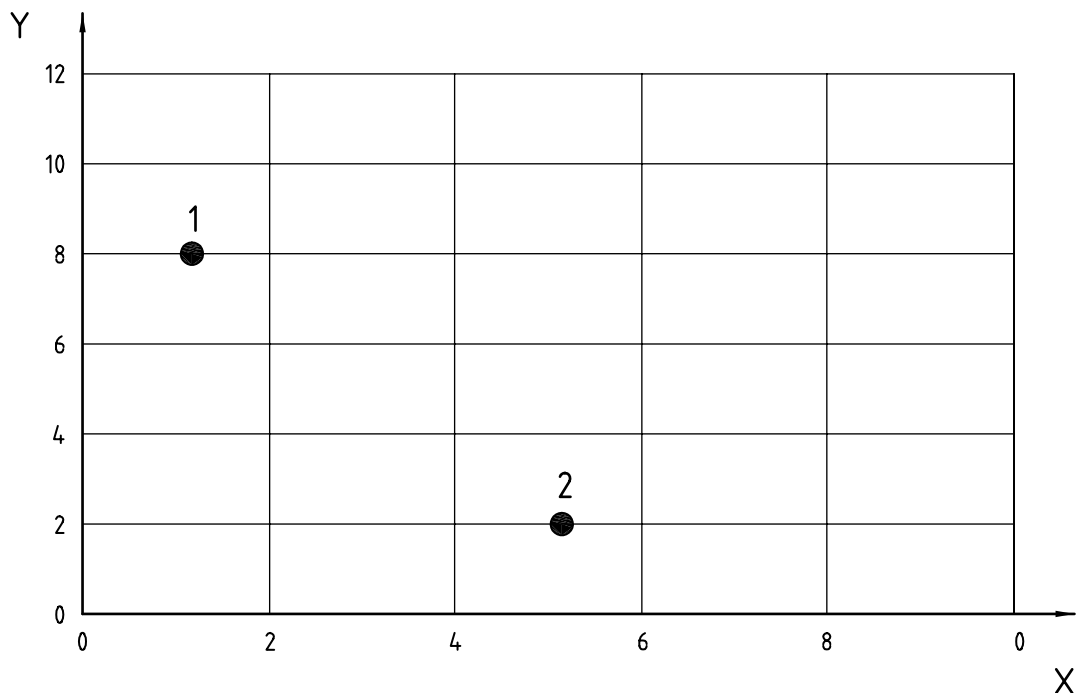

Key

- X length of work period, min
- Y length of rest pause, min
- 1 Example 1
- 2 Example 2

Figure 1 — Curve showing limit of validity of combinations of work and rest periods when estimating metabolic rate

5.5 Obtaining values by interpolation

It is possible to obtain metabolic-rate values by interpolation. When working speeds differ from those given in the tables in Annex B, conversion is only possible within a range of $\pm 25\%$ of the indicated speed, however.

5.6 Requirements for the application of metabolic-rate tables

To allow comparison of values from different sources, values reported in the tables in Annexes A and B have been standardized with respect to the standard person working in a comfortable thermal environment.

The metabolic rate for a given person performing a given task may vary within certain limits around the mean values given in the tables, due to the influence of the factors mentioned in Clause 3.

However, it can be estimated that:

- for the same work and under the same working conditions, the metabolic rate can vary from person to person by about $\pm 5\%$;
- for a person trained in the activity, the variation is about 5% under laboratory conditions;
- under field conditions, i.e. when the activity to be measured is not exactly the same from test to test, a variation of up to 20% can be expected.

Considering this risk of error, it is normally not justified, at this level of evaluation, to take into consideration differences in height or gender.

The consideration of the weight of the subject might be warranted only for activities involving movements of the whole body, such as walking, climbing, lifting weights.

In hot conditions, a maximum increase of $5\text{ W}\cdot\text{m}^{-2}$ to $10\text{ W}\cdot\text{m}^{-2}$ may be expected due to increased heart rate and sweating. Such a correction is not justified.

On the other hand, in cold conditions, an increase of up to $200\text{ W}\cdot\text{m}^{-2}$ may be observed when shivering occurs. The wearing of heavy clothing will also increase metabolic rate, by increasing the weight of the subject and decreasing the subject's ease of movement.

6 Level 3, analysis

6.1 Estimation of metabolic rate using heart rate

The heart rate at a given time may be regarded as the sum of several components:

$$\text{HR} = \text{HR}_0 + \Delta\text{HR}_M + \Delta\text{HR}_S + \Delta\text{HR}_T + \Delta\text{HR}_N + \Delta\text{HR}_E \quad (2)$$

where

HR_0 is the heart rate, in beats per minute, at rest in a prone position under neutral thermal conditions;

ΔHR_M is the increase in heart rate, in beats per minute, due to dynamic muscular load, under neutral thermal conditions;

ΔHR_S is the increase in heart rate, in beats per minute, due to static muscular work (this component depends on the relationship between the force used and the maximum voluntary force of the working muscle group);

ΔHR_T is the increase in heart rate, in beats per minute, due to heat stress (the thermal component is discussed in ISO 9886);

ΔHR_N is the increase in heart rate, in beats per minute, due to mental load;

ΔHR_E is the change in heart rate, in beats per minute, due to other factors, for example respiratory effects, circadian rhythms, dehydration.

In the case of dynamic work using major muscle groups, with only a small amount of static muscular load and in the absence of thermal strain and mental loads, the metabolic rate may be estimated by measuring the heart rate while working. Under such conditions, a linear relationship exists between the metabolic rate and the heart rate. If the above-mentioned restrictions are taken into account, this method can be more accurate than the level 1 and level 2 methods of estimation (see Table 1) and is less complex than the measurement of oxygen consumption, which provides the most accurate results.

The heart rate may be recorded continuously, for example by the use of telemetric equipment, or, with a further reduction in accuracy, measured manually by counting the arterial pulse rate (see ISO 9886).

The mean heart rate HR may be computed over fixed time intervals, for example 1 min, over different working cycles or over the whole shift time.

In the presence of considerable thermal load, static muscular work, dynamic work with small muscle groups and/or mental loads, the slope and form of the heart rate to metabolic rate relationship can change drastically. The procedure used to correct the heart rate measurements for thermal effects is described in ISO 9886.

6.2 Relationship between heart rate and metabolic rate

The relationship between heart rate and metabolic rate can be measured by recording the heart rate at different stages of defined muscular load during an experiment in a neutral climatic environment. Heart rate and corresponding oxygen consumption or physical work performed is measured during dynamic muscular work at different load stages. As the type of work (cycle ergometer, step test, treadmill) and the sequence and duration of the load stages have an influence on both parameters, it is necessary to use a standardized procedure.

In general, linearity holds true for the range extending

- from a lower limit of 120 beats per minute (bpm), because the mental component can then be neglected;
- up to 20 beats below the maximum heart rate of the subject, because the heart rate tends to level off above this value.

Within this range, the relationship between heart rate and metabolic rate can be written as:

$$HR = HR_0 + RM \times (M - M_0) \quad (3)$$

where

M is the metabolic rate, in watts per square metre;

M_0 is the metabolic rate at rest, in watts per square metre;

RM is the increase in heart rate per unit of metabolic rate;

HR_0 is the heart rate at rest, under neutral thermal conditions.

This relationship is used to derive the metabolic rate from the measured heart rate.

When this expression is derived from HR and M measurements during an experiment, the precision can be estimated at about 10 %.

With a further loss of accuracy, the expression can be derived from estimations of:

- the heart rate at rest under neutral thermal conditions HR_0 ;
- the metabolic rate at rest M_0 (= 55 watts per square metre);
- the maximum working capacity MWC, estimated using the following formulae as a function of age (A , in years) and weight (P , in kg):

$$\text{Men: } MWC = (41,7 - 0,22A)P^{0,666} \text{ W}\cdot\text{m}^{-2} \quad (4)$$

$$\text{Women: } MWC = (35,0 - 0,22A)P^{0,666} \text{ W}\cdot\text{m}^{-2} \quad (5)$$

- the maximum heart rate HR_{\max} , estimated by the following formula:

$$HR_{\max} = 205 - 0,62A \quad (6)$$

- $RM = (HR_{\max} - HR_0)/(MWC - M_0)$ (7)

Table C.1 in Annex C provides directly estimations of the HR - M relationship for ages ranging from 20 years to 60 years and weights ranging from 50 kg to 90 kg. The precision, in that case, is further reduced.

7 Level 4, expertise

7.1 Determination of metabolic rate by measurement of oxygen consumption rate

7.1.1 Partial and integral methods

The metabolic rate can be determined by two main methods:

- the partial method, to be used for light and moderately heavy work;
- the integral method, to be used for heavy work of short duration.

The use of these two methods is justified as follows:

- In the case of light and moderate work, the oxygen uptake reaches a steady state equal to the oxygen requirement after a short period of work.
- In the case of heavy work, the oxygen requirement is above the long-term limit of aerobic power and, in the case of very heavy work, above the maximum aerobic power. During heavy work, the oxygen uptake cannot satisfy the oxygen requirement. The oxygen deficit is balanced after work has ceased. Thus, the measurement includes the work period and the subsequent rest period. The integral method shall be used for an oxygen consumption rate of more than 60 litres of oxygen per hour (60 l O_2 /h), equivalent to 1 litre of oxygen per minute.

Figure 2 shows the procedure to be followed when using the partial method.

Since the steady state is only reached after 3 min to 5 min, the collection of expired air starts after about 5 min (preliminary period), without interrupting the work. The work continues for 5 min to 10 min (main period). Air collection can be either complete (for example with a Douglas bag) or by regular sampling (for example with a gas-meter). It is stopped when work ceases.

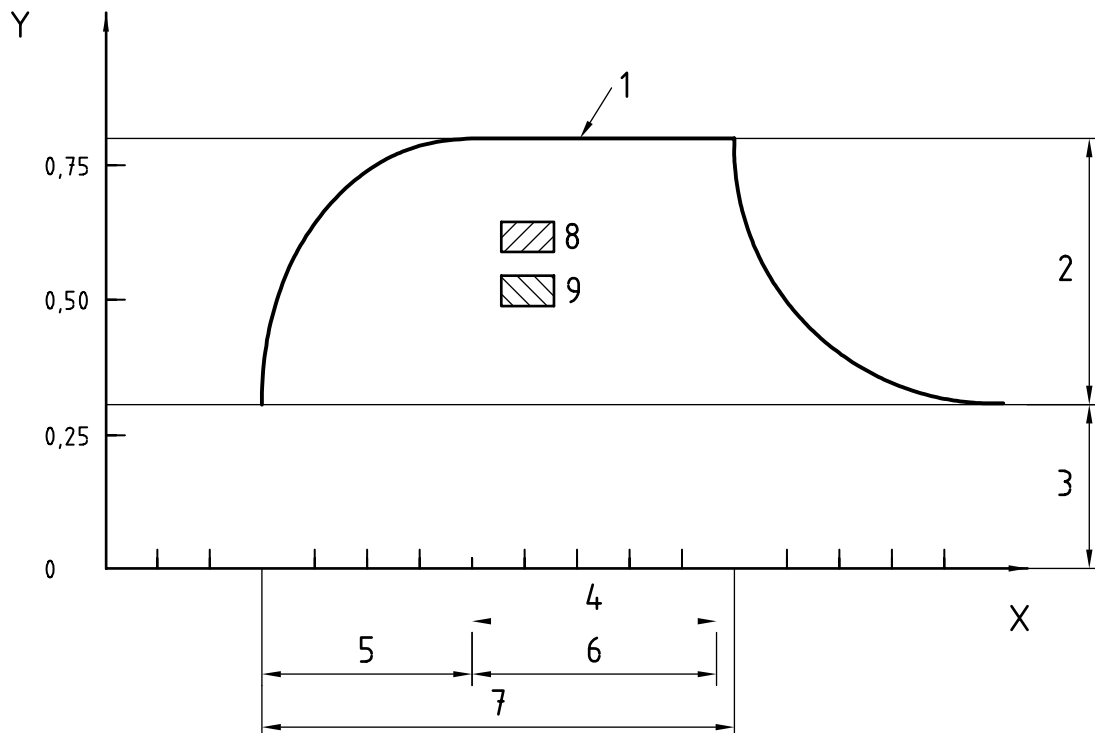

Key

X time, min

Y oxygen uptake, $l \cdot \text{min}^{-1}$

1	O_2 requirement	6	main period
2	increase in metabolic rate due to work	7	work period
3	baseline metabolic rate	8	O_2 deficit
4	measurement period	9	O_2 debt repayment
5	preliminary period		

Figure 2 — Measurement of metabolic rate using the partial method

With the integral method (see Figure 3), expired-air collection is started immediately at the beginning of the work period and the work is continued for a certain time, usually for not more than 2 min to 3 min (main period). At the end of the work period, the subject is asked to sit down and air collection is continued until the resting value is reached. During this recovery period, the oxygen debt incurred during the work is repaid. Since the measurement includes the working (main period) and sitting (recovery period) activity, the metabolic rate needed for sitting has to be subtracted from the measured value in order to obtain the metabolic rate related to the work alone.

It is necessary to record the course of the work (time and motion study) and the frequency of repeated activities for further evaluation of the results and for comparison of the metabolic rate with data in the literature. Examples of the calculation of metabolic rate are given in Annex D.

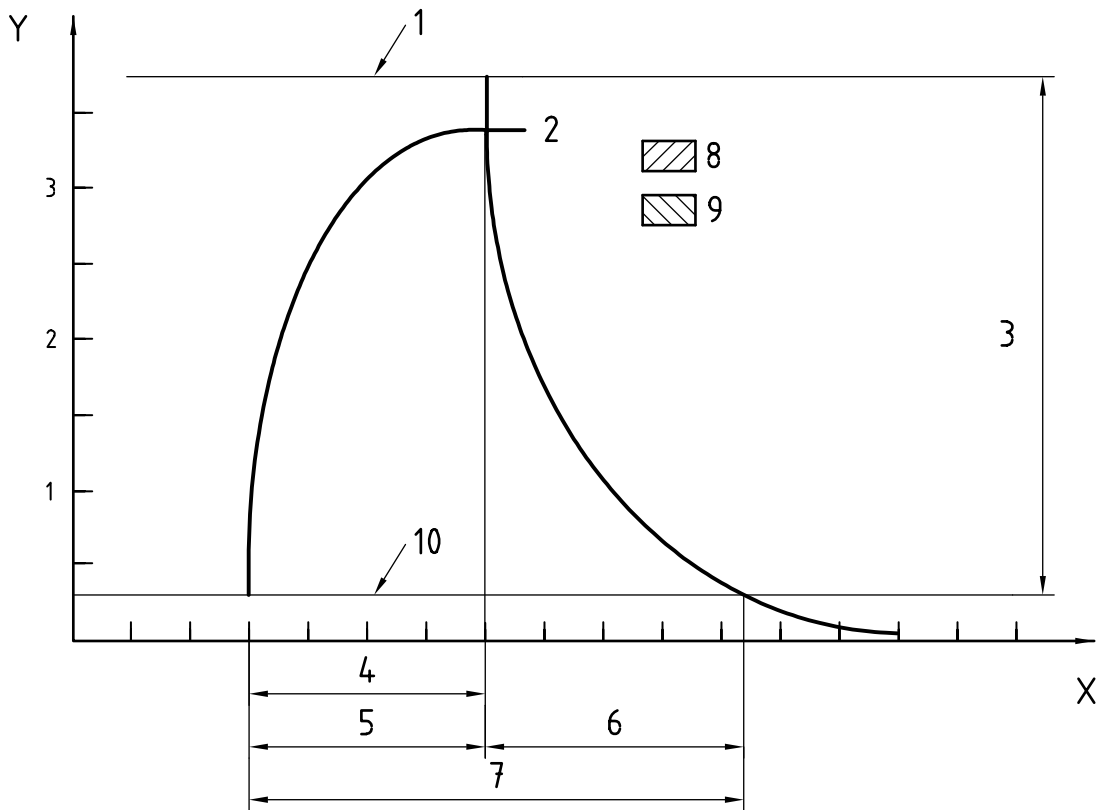

Key

- | | | | |
|---|--|----|-------------------------------|
| X | time, min | | |
| Y | oxygen uptake, l·min ⁻¹ | | |
| 1 | O ₂ requirement | 6 | recovery period |
| 2 | maximum aerobic power | 7 | measurement period |
| 3 | increase in metabolic rate due to work | 8 | O ₂ deficit |
| 4 | work period | 9 | O ₂ debt repayment |
| 5 | main period | 10 | baseline metabolic rate |

Figure 3 — Measurement of metabolic rate using the integral method

7.1.2 Determination of metabolic rate from oxygen consumption rate

Since the human body can only store very small amounts of oxygen, it must be continuously taken up from the atmosphere by respiration. Muscles can work for a short time without being directly provided with oxygen (anaerobic work) but, for longer periods of work, oxidative metabolism is the major energy source.

The metabolic rate can be determined, therefore, by measuring oxygen consumption rate. The energetic equivalent (EE) of oxygen is used to convert oxygen consumption rate into metabolic rate.

The energetic equivalent depends on the type of metabolism that is indicated by the respiratory quotient (RQ). In the determination of the metabolic rate, the use of a mean RQ of 0,85 and thereby of an EE of 5,68 W·h/l O₂ is often sufficient. In that case, measurement of the carbon dioxide production rate is not required. The maximum possible error is ± 3,5 %, but generally the error will not exceed 1 %.

The metabolic rate can be determined from the following equations:

$$RQ = \frac{\dot{V}_{CO_2}}{\dot{V}_{O_2}} \tag{8}$$

$$EE = (0,23RQ + 0,77)5,88 \quad (9)$$

$$M = EE \times \dot{V}_{O_2} \times \frac{1}{A_{Du}} \quad (10)$$

where

RQ is the respiratory quotient;

\dot{V}_{O_2} is the oxygen consumption rate, in litres of oxygen per hour;

\dot{V}_{CO_2} is the carbon dioxide production rate, in litres of carbon dioxide per hour;

EE is the energetic equivalent, in watt hours per litre of oxygen (W·h/l O₂);

M is the metabolic rate, in watts per square metre;

A_{Du} is the body surface area, in square metres, given by the Du Bois formula:

$$A_{Du} = 0,202 \times W_b^{0,425} \times H_b^{0,725} \quad (11)$$

in which

W_b is the body weight, in kilograms;

H_b is the body height, in metres.

7.1.3 Determination of oxygen uptake

The procedure for determining the oxygen uptake is described in the following subclauses.

7.1.3.1 Calculation of the STPD reduction factor

The determination of the oxygen uptake requires the following data to be measured or recorded:

- the personal data: sex, weight, height, age;
- the method of measurement;
- the duration of the measurement: partial method or integral method as described in 7.1.1;
- the atmospheric pressure;
- the volume of air expired;
- the temperature of the expired air;
- the fraction of oxygen in the expired air;
- the fraction of carbon dioxide in the expired air if determination of RQ is required.

The gas volume shall be related to $\theta = 0$ °C, $p = 101,3$ kPa (normal atmospheric pressure) for a dry gas (i.e. STPD conditions: standard temperature and pressure, dry). As the collected air is saturated with water vapour (the saturation pressure of which is a function of temperature) and its temperature is determined by ambient temperature (ATPS conditions: atmospheric temperature and pressure, saturated), the reduction factor f can be calculated from the following equation using the partial pressure of water vapour (see Table 2).

$$f = \frac{273 \times (p - p_{H_2O})}{(273 + \theta) \times 101,3} \quad (12)$$

where

f is the STPD reduction factor;

p is the measured atmospheric pressure, in kilopascals;

θ is the temperature of the expired air, in degrees Celsius, measured in the gas-meter or assumed the ambient temperature when a Douglas bag is used;

p_{H_2O} is the partial pressure of the saturated water vapour, in kilopascals, corresponding to the temperature θ (see Table 2).

Table 2 — Saturated water vapour pressure (in kPa) for temperatures between 10 °C and 37 °C (1 °C steps)

Temperature (°C)	0	1	2	3	4	5	6	7	8	9
10	1,23	1,31	1,40	1,50	1,60	1,70	1,82	1,94	2,06	2,20
20	2,34	2,49	2,64	2,81	2,98	3,17	3,36	3,56	3,78	4,00
30	4,24	4,49	4,75	5,03	5,32	5,62	5,94	6,27	—	—

If the collected expired air is heated up by the environment to a temperature in excess of 37 °C, the saturated water vapour pressure of 6,27 kPa at the temperature of 37 °C shall be used.

7.1.3.2 Calculation of the expired volume at STPD

$$V_{exSTPD} = V_{exATPS} \times f \quad (13)$$

where

V_{exSTPD} is the expired volume, in litres, at STPD;

V_{exATPS} is the expired volume, in litres, at ATPS;

f is as defined in 7.1.3.1.

7.1.3.3 Calculation of the volume flow rate

$$\dot{V}_{ex} = \frac{V_{exSTPD}}{t} \quad (14)$$

where

\dot{V}_{ex} is the volume flow rate, in litres per hour;

t is the test duration, in hours, i.e. the main period for the partial method and the main and recovery periods for the integral method.

7.1.3.4 Calculation of oxygen consumption rate

$$\dot{V}_{O_2} = \dot{V}_{ex} \times (0,209 - F_{O_2}) \quad (15)$$

where

\dot{V}_{O_2} is the oxygen consumption rate, in litres of oxygen per hour;

F_{O_2} is the fraction of oxygen in the expired air.

7.1.3.5 Calculation of carbon dioxide production rate

$$\dot{V}_{CO_2} = \dot{V}_{ex} \times (F_{CO_2} - 0,0003) \quad (16)$$

where

\dot{V}_{CO_2} is the carbon dioxide production rate, in litres of carbon dioxide per hour;

F_{CO_2} is the fraction of carbon dioxide in the expired air.

7.1.3.6 The effect of contraction of the expired volume

The inspired and expired volumes are not equal if $RQ \neq 1$. Contraction can be taken into account using the following equations:

$$\dot{V}_{O_2} = \dot{V}_{ex} [0,265(1 - F_{O_2} - F_{CO_2}) - F_{O_2}] \quad (17)$$

$$\dot{V}_{CO_2} = \dot{V}_{ex} [F_{CO_2} - (1 - F_{O_2} - F_{CO_2}) 0,380 \times 10^{-3}] \quad (18)$$

7.1.4 Calculation of metabolic rate

7.1.4.1 Partial method

The metabolic rate is determined from the oxygen uptake and the energetic equivalent using Equation (10).

7.1.4.2 Integral method

The following calculation shall be carried out when using the integral method, as only the difference between the total measured metabolic rate and the known metabolic rate for the activity during the recovery period, i.e. sitting, is related to the work itself.

First, the metabolic rate is derived as in the partial method, and then the following conversion is performed:

$$M = \left(M_p \times \frac{t_m + t_r}{t_m} \right) - \left(M_s \times \frac{t_r}{t_m} \right) \quad (19)$$

where

M is the metabolic rate, in watts per square metre;

M_p is the metabolic rate, in watts per square metre, for the partial method;

M_s is the metabolic rate, in watts per square metre, when seated;

t_m is the length of the main period, in minutes;

t_r is the length of the recovery period, in minutes.

7.2 The doubly labelled water method for long-term measurements

This subclause describes only the principle of the method.

After collection of a baseline urine sample, the subject drinks an accurately weighed oral loading dose of $^2\text{H}_2^{18}\text{O}$.

Deuterium (^2H) labels the body water pool and its rate of disappearance from the body (k_2) provides a measure of water turnover ($r_{\text{H}_2\text{O}}$).

The ^{18}O labels both the water and bicarbonate pools which are in rapid equilibrium through the carbonic anhydrase reaction.

The rate of disappearance of ^{18}O (k_{18}) provides a measure of the combined turnover of water and bicarbonate ($r_{\text{H}_2\text{O}} + r_{\text{CO}_2}$). Therefore, bicarbonate turnover (i.e. the subject's carbon dioxide production rate) can be calculated as the difference between the two rate constants ($k_{18} - k_2$).

Carbon dioxide production rate can be converted to energy expenditure using classical indirect calorimetric calculations. The initial dilution of the isotopes provides a measure of the ^2H and ^{18}O spaces, which are useful in calculating body composition.

The method requires the measurements to be made over at least two biological half-lives of the isotopes: in children, the minimum test duration is about 6 days, in normal adults it is about 12 days to 14 days, and in the elderly it may be longer.

The doubly labelled water (DLW) method has been cross-validated against whole-body calorimetry and intake/balance procedures in a number of studies. None of these has recorded a significant discrepancy between DLW and the comparator method in subjects under steady-state conditions. The overall precision of the method is about $\pm 5\%$, depending on circumstances.

Although the DLW technique is simple in concept, there are a number of complex details that must be thoroughly understood by the user.

7.3 Direct calorimetry — Principle

Direct calorimetry measures energy expenditure as the rate at which heat is lost from the body to the environment. This heat is transferred through non-evaporative heat loss (radiation, convection, conduction) and through the evaporation of water. Direct calorimetry is usually a whole-body measurement made within the confines of a chamber, but has also been carried out using a heat-exchanging body suit. The non-evaporative components of heat exchange are measured passively in terms of the temperature gradient across the walls of a poorly insulated chamber (gradient layer calorimetry), or actively by measuring the rate at which heat must be extracted from a chamber to avoid heat loss through well-insulated walls (heat sink calorimetry). Evaporative heat loss affects the moisture content of the environment and requires independent measurement. It is measured either by condensing the water appearing in the chamber and measuring the latent water content of the air (without condensation) or calculating its associated latent heat of evaporation. Total heat loss is estimated as the sum of the evaporative and non-evaporative components.

Annex A (informative)

Evaluation of the metabolic rate at level 1, screening

This annex provides the data to use for simply and easily characterizing the mean workload for a given occupation or for a given activity in accordance with the two methods given for level 1, screening:

Method 1A: Classification according to occupation

Table A.1 — Metabolic rate for various occupations

Occupation		Metabolic rate ($W \cdot m^{-2}$)
Office work	Sedentary work	55 to 70
	Clerical work	70 to 100
	Janitor	80 to 115
Craftsmen	Bricklayer	110 to 160
	Carpenter	110 to 175
	Glazier	90 to 125
	Painter	100 to 130
	Baker	110 to 140
	Butcher	105 to 140
	Clock and watch repairer	55 to 70
Mining industry	Haulage operator	70 to 85
	Coal hewer	110
	Cokeoven worker	115 to 175
Iron and steel industry	Blast furnace worker	170 to 220
	Electric furnace worker	125 to 145
	Hand moulder	140 to 240
	Machine moulder	105 to 165
Iron and metal-working industry	Foundry man	140 to 240
	Smith	90 to 200
	Welder	75 to 125
	Turner	75 to 125
	Drilling machine operator	80 to 140
Graphic occupations	Precision mechanic	70 to 110
	Hand compositor	70 to 95
Agriculture	Book-binder	75 to 100
	Gardener	115 to 190
Traffic	Tractor driver	85 to 110
	Car driver	70 to 100
	Bus driver	75 to 125
	Tramway driver	80 to 115
	Crane operator	65 to 145
Various occupations	Laboratory assistant	85 to 100
	Teacher	85 to 100
	Shop assistant	100 to 120
	Secretary	70 to 85

Method 1B: Classification according to the kind of activity

Table A.2 — Classification of metabolic rate by category

Class	Average metabolic rate (with range in brackets)		Examples
	W·m ⁻²	W	
0 Resting	65 (55 to 70)	115 (100 to 125)	Resting, sitting at ease
1 Low metabolic rate	100 (70 to 130)	180 (125 to 235)	Light manual work (writing, typing, drawing, sewing, book-keeping); hand and arm work (small bench tools, inspection, assembly or sorting of light materials); arm and leg work (driving vehicle in normal conditions, operating foot switch or pedal). Standing drilling (small parts); milling machine (small parts); coil winding; small armature winding; machining with low power tools; casual walking (speed up to 2,5 km·h ⁻¹).
2 Moderate metabolic rate	165 (130 to 200)	295 (235 to 360)	Sustained hand and arm work (hammering in nails, filing); arm and leg work (off-road operation of lorries, tractors or construction equipment); arm and trunk work (work with pneumatic hammer, tractor assembly, plastering, intermittent handling of moderately heavy material, weeding, hoeing, picking fruits or vegetables, pushing or pulling lightweight carts or wheelbarrows, walking at a speed of 2,5 km·h ⁻¹ to 5,5 km·h ⁻¹ , forging).
3 High metabolic rate	230 (200 to 260)	415 (360 to 465)	Intense arm and trunk work; carrying heavy material; shovelling; sledgehammer work; sawing; planing or chiselling hard wood; hand mowing; digging; walking at a speed of 5,5 km·h ⁻¹ to 7 km·h ⁻¹ . Pushing or pulling heavily loaded hand carts or wheelbarrows; chipping castings; concrete block laying.
4 Very high metabolic rate	290 (>260)	520 (>465)	Very intense activity at fast to maximum pace; working with an axe; intense shovelling or digging; climbing stairs, ramp or ladder; walking quickly with small steps; running; walking at a speed greater than 7 km·h ⁻¹ .

Annex B (informative)

Evaluation of the metabolic rate at level 2, observation

This annex provides the data to use for characterizing on average a working situation at a specific time in accordance with the two methods given for level 2, observation:

- Method A: the metabolic rate is determined by adding to the baseline metabolic rate the metabolic rate for body posture, the metabolic rate for the type of work and the metabolic rate for the body motion related to work speed (using group assessment tables).
- Method B: the metabolic rate is determined by means of the tabulated values for various activities.

Table B.1 — Metabolic rate (in $W \cdot m^{-2}$) for a seated subject as a function of workload and body segment involved

Body segment		Workload		
		Light	Medium	Heavy
Both hands	Mean	70	85	95
	Range	<75	75 to 90	>90
One arm	Mean	90	110	130
	Range	<100	100 to 120	>120
Both arms	Mean	120	140	160
	Range	<130	130 to 150	>150
The body	Mean	180	245	335
	Range	<210	210 to 285	>285

Table B.2 — Supplement to metabolic rate (in $W \cdot m^{-2}$) for body postures

Body posture	Metabolic rate ($W \cdot m^{-2}$)
Sitting	0
Kneeling	10
Crouching	10
Standing	15
Standing stooped	20

Table B.3 — Metabolic rate for specific activities

Activity	W·m ⁻²
Sleeping	40
Reclining	45
At rest, sitting	55
At rest, standing	70
Walking on the level, even path, solid	
1. without load at 2 km·h ⁻¹	110
at 3 km·h ⁻¹	140
at 4 km·h ⁻¹	165
at 5 km·h ⁻¹	200
2. with load 10 kg, 4 km·h ⁻¹	185
30 kg, 4 km·h ⁻¹	250
Walking uphill, even path, solid	
1. without load 5° inclination, 4 km·h ⁻¹	180
15° inclination, 3 km·h ⁻¹	210
25° inclination, 3 km·h ⁻¹	300
2. with load of 20 kg 15° inclination, 4 km·h ⁻¹	270
25° inclination, 4 km·h ⁻¹	410
Walking downhill at 5 km·h ⁻¹ , without load 5° inclination	135
15° inclination	140
25° inclination	180
Ladder at 70°, climbing at a rate of 11,2 m·min ⁻¹	
without load	290
with a 20 kg load	360
Pushing or pulling a tip-wagon, 3,6 km·h ⁻¹ , even path, solid	
pushing force: 12 kg	290
pulling force: 16 kg	375
Pushing a wheelbarrow, even path, 4,5 km·h ⁻¹ , rubber tyres, 100 kg load	230
Filing iron 42 file strokes/min	100
60 file strokes/min	190
Work with a hammer, 2 hands, mass of the hammer 4,4 kg, 15 strokes/min	290
Carpentry work hand sawing	220
machine sawing	100
hand planing	300
Brick-laying, 5 bricks/min	170
Screw driving	100
Digging a trench	290
Sedentary activity (office, dwelling, school, laboratory)	70
Standing, light activity (shopping, laboratory, light industry)	95
Standing, medium activity (shop assistant, domestic work, machine work)	115
Work on a machine tool	
Light (adjusting, assembling)	100
Medium (loading)	140
Heavy	210
Work with a hand tool	
Light (light polishing)	100
Medium (polishing)	160
Heavy (heavy drilling)	230

Table B.4 — Diary-form for recording activities

Date	
Subject	
Workplace	
Air temperature, °C	
Black-globe temperature, °C	
Air humidity, RH %	
Air velocity, m/s	
Clothing	

Table B.5 — Table summarizing the diary results

Occupation/work task Date:						
Category		<i>M</i>		Time		Total
		W·m ⁻²		min		
1	Task 1	<i>M</i> ₁	×		=	
2	Task 2	<i>M</i> ₂	×		=	
...	×		=	
<i>i</i>	Task <i>i</i>	<i>M</i> _{<i>i</i>}	×		=	
...	×		=	
<i>n</i>	Task <i>n</i>	<i>M</i> _{<i>n</i>}	×		=	
	Total		
	Time-weighted average metabolic rate				

Annex C (informative)

Evaluation of the metabolic rate at level 3, analysis

This annex provides the data to use for estimating the metabolic rate from heart rate recordings over a representative period in accordance with the method given for level 3, analysis:

Table C.1 — Relationship between metabolic rate (in $W \cdot m^{-2}$) and heart rate (in beats per min), predicted as a function of the age and the weight of the subject (for women and men)
(to obtain the metabolic rate, multiply the heart rate HR by the figure on the left in each case and then subtract the figure on the right)

Age (years)	Weight (kg)				
	50 kg	60 kg	70 kg	80 kg	90 kg
Women					
20	$2,9 \times HR - 150$	$3,4 \times HR - 181$	$3,8 \times HR - 210$	$4,2 \times HR - 237$	$4,5 \times HR - 263$
30	$2,8 \times HR - 143$	$3,3 \times HR - 173$	$3,7 \times HR - 201$	$4,0 \times HR - 228$	$4,4 \times HR - 254$
40	$2,7 \times HR - 136$	$3,1 \times HR - 165$	$3,5 \times HR - 192$	$3,9 \times HR - 218$	$4,3 \times HR - 244$
50	$2,6 \times HR - 127$	$3,0 \times HR - 155$	$3,4 \times HR - 182$	$3,7 \times HR - 207$	$4,1 \times HR - 232$
60	$2,5 \times HR - 117$	$2,9 \times HR - 145$	$3,2 \times HR - 170$	$3,6 \times HR - 195$	$3,9 \times HR - 219$
Men					
20	$3,7 \times HR - 201$	$4,2 \times HR - 238$	$4,7 \times HR - 273$	$5,2 \times HR - 307$	$5,6 \times HR - 339$
30	$3,6 \times HR - 197$	$4,1 \times HR - 233$	$4,6 \times HR - 268$	$5,1 \times HR - 301$	$5,5 \times HR - 333$
40	$3,5 \times HR - 192$	$4,0 \times HR - 228$	$4,5 \times HR - 262$	$5,0 \times HR - 295$	$5,4 \times HR - 326$
50	$3,4 \times HR - 186$	$4,0 \times HR - 222$	$4,4 \times HR - 256$	$4,9 \times HR - 288$	$5,3 \times HR - 319$
60	$3,4 \times HR - 180$	$3,9 \times HR - 215$	$4,5 \times HR - 249$	$4,8 \times HR - 280$	$5,2 \times HR - 311$

Annex D (informative)

Evaluation of the metabolic rate at level 4, expertise — Examples of the calculation of metabolic rate based on measured data

An example of the calculation of metabolic rate for both the partial and the integral methods is given below. A gas-meter was used to collect the expired gases.

D.1 Calculation of metabolic rate by the partial method

D.1.1 Personal data

Sex: male

Age: 35 years

Height: 1,75 m

Weight: 75 kg

A_{Du} : 1,90 m²

D.1.2 Duration of measurement

Preliminary period: 0,05 h (3 min)

Main period: 0,2 h (12 min)

D.1.3 Atmospheric pressure: $p = 100,8$ kPa

D.1.4 Measured values

D.1.4.1 Gas-meter

Correction factor for the gas-meter = 0,998

Temperature of the gas-meter (i.e. temperature θ of the expired air) = 26,8 °C

Final reading of the gas-meter = 7 981,2 litres

Initial reading of the gas-meter = 7 775,0 litres

Ventilation = 206,2 litres

D.1.4.2 Fraction of oxygen and carbon dioxide in the expired air

Fraction of oxygen F_{O_2} 0,162

Fraction of carbon dioxide F_{CO_2} 0,042

D.1.5 Calculation of the expired volume

The expired volume $V_{\text{ex,ATPS}}$ is calculated from the ventilation and the correction factor of the gas-meter:

$$V_{\text{ex,ATPS}} = 206,2 \times 0,998 = 205,8 \text{ litres}$$

The STPD reduction factor is calculated from Equation (12):

$$f = \frac{273 \times (100,8 - 3,52)}{(273 + 26,8) \times 101,3} = 0,874$$

Thus

$$V_{\text{ex,STPD}} = V_{\text{ex,ATPS}} \times f = 205,8 \times 0,874 = 179,9 \text{ litres}$$

D.1.6 Calculation of the volume flow rate

$$\dot{V}_{\text{ex}} = V_{\text{ex,STPD}}/t = 179,9/0,2 = 899,5 \text{ l/h}$$

D.1.7 Calculation of the oxygen consumption rate

$$\dot{V}_{\text{O}_2} = \dot{V}_{\text{ex}} \times (0,209 - F_{\text{O}_2}) = 899,5(0,209 - 0,162) = 42,3 \text{ l O}_2/\text{h}$$

D.1.8 Calculation of the carbon dioxide production rate

$$\dot{V}_{\text{CO}_2} = \dot{V}_{\text{ex}} \times (F_{\text{CO}_2} - 0,0003) = 899,5(0,042 - 0,0003) = 37,5 \text{ l CO}_2/\text{h}$$

D.1.9 Consideration of the shrinkage of the expired volume

$$\begin{aligned} \dot{V}_{\text{O}_2} &= \dot{V}_{\text{ex}} [0,265(1 - F_{\text{O}_2} - F_{\text{CO}_2}) - F_{\text{O}_2}] \\ &= 899,5 [0,265(1 - 0,162 - 0,042) - 0,162] = 44,0 \text{ l O}_2/\text{h} \end{aligned}$$

$$\begin{aligned} \dot{V}_{\text{CO}_2} &= \dot{V}_{\text{ex}} [F_{\text{CO}_2} - 0,00038(1 - F_{\text{O}_2} - F_{\text{CO}_2})] \\ &= 899,5 [0,042 - 0,00038(1 - 0,162 - 0,042)] = 37,5 \text{ l CO}_2/\text{h} \end{aligned}$$

D.1.10 Calculation of the metabolic rate

$$\text{RQ} = \frac{\dot{V}_{\text{CO}_2}}{\dot{V}_{\text{O}_2}} = 37,5/44,0 = 0,852$$

$$\text{EE} = (0,23\text{RQ} + 0,77) \times 5,88 = 5,68 \text{ W}\cdot\text{h/l O}_2$$

$$M = \text{EE} \times \dot{V}_{\text{O}_2} \times \frac{1}{A_{\text{Du}}} = 5,68 \times 44,0/1,9 = 131,5 \text{ W}\cdot\text{m}^{-2}$$

Due to the limits of accuracy attainable, the result may be rounded to $132 \text{ W}\cdot\text{m}^{-2}$.

D.2 Calculation of the metabolic rate using the integral method

Correction of the expired volume and calculation of RQ using CO_2 production are omitted in this example, because these corrections have no significant effect on the final result.

D.2.1 Personal data: same as in D.1.1

D.2.2 Duration of measurement

Main period = 0,05 h (3 min)

Recovery period = 0,15 h (9 min)

Test duration = 0,2 h (12 min)

D.2.3 Atmospheric pressure: $p = 100,8$ kPa

D.2.4 Measured values

D.2.4.1 Gas-meter

Correction factor for the gas-meter = 0,998

Temperature of the gas-meter = 26,8 °C

Final reading of the gas-meter = 5 877,5 litres

Initial reading of the gas-meter = 5 707,0 litres

Ventilation = 170,5 litres

D.2.4.2 Fraction of oxygen in the expired air

Fraction of oxygen $F_{\text{O}_2} = 0,155$

D.2.5 Calculation of the expired volume

The expired volume $V_{\text{ex}}^{\text{ATPS}}$ is calculated from the ventilation and the correction factor of the gas-meter:

$$V_{\text{ex}}^{\text{ATPS}} = 170,5 \times 0,998 = 170,2 \text{ litres}$$

The STPD reduction factor has the same value as in D.1.5. Thus

$$V_{\text{ex}}^{\text{STPD}} = V_{\text{ex}}^{\text{ATPS}} \times f = 170,2 \times 0,874 = 148,8 \text{ litres}$$

D.2.6 Calculation of the volume flow rate

$$\dot{V}_{\text{ex}} = V_{\text{ex}}^{\text{STPD}}/t = 148,8/0,2 = 744,0 \text{ l/h}$$

D.2.7 Calculation of the oxygen consumption rate

$$\dot{V}_{\text{O}_2} = \dot{V}_{\text{ex}} \times (0,209 - F_{\text{O}_2}) = 40,2 \text{ l O}_2/\text{h}$$

D.2.8 Calculation of the metabolic rate

Using a mean RQ of 0,85 and thereby an energetic equivalent of 5,68 W·h/l O₂, the following result is obtained:

$$M = EE \times \dot{V}_{O_2} \times \frac{1}{A_{Du}} = 5,68 \times 40,2/1,9 = 120,2 \text{ W}\cdot\text{m}^{-2}$$

In order to relate the metabolic rate to the main period, the conversion according to Equation (18) is performed.

The metabolic rate for sitting being 55 W·m⁻²

$$M = 120,2 \times 0,2/0,05 - 55 \times 0,15/0,05 = 318,8 \text{ W}\cdot\text{m}^{-2}$$

Due to the limits of accuracy attainable, the result may be rounded to 320 W·m⁻².

BSI — British Standards Institution

BSI is the independent national body responsible for preparing British Standards. It presents the UK view on standards in Europe and at the international level. It is incorporated by Royal Charter.

Revisions

British Standards are updated by amendment or revision. Users of British Standards should make sure that they possess the latest amendments or editions.

It is the constant aim of BSI to improve the quality of our products and services. We would be grateful if anyone finding an inaccuracy or ambiguity while using this British Standard would inform the Secretary of the technical committee responsible, the identity of which can be found on the inside front cover. Tel: +44 (0)20 8996 9000. Fax: +44 (0)20 8996 7400.

BSI offers members an individual updating service called PLUS which ensures that subscribers automatically receive the latest editions of standards.

Buying standards

Orders for all BSI, international and foreign standards publications should be addressed to Customer Services. Tel: +44 (0)20 8996 9001. Fax: +44 (0)20 8996 7001. Email: orders@bsi-global.com. Standards are also available from the BSI website at <http://www.bsi-global.com>.

In response to orders for international standards, it is BSI policy to supply the BSI implementation of those that have been published as British Standards, unless otherwise requested.

Information on standards

BSI provides a wide range of information on national, European and international standards through its Library and its Technical Help to Exporters Service. Various BSI electronic information services are also available which give details on all its products and services. Contact the Information Centre. Tel: +44 (0)20 8996 7111. Fax: +44 (0)20 8996 7048. Email: info@bsi-global.com.

Subscribing members of BSI are kept up to date with standards developments and receive substantial discounts on the purchase price of standards. For details of these and other benefits contact Membership Administration. Tel: +44 (0)20 8996 7002. Fax: +44 (0)20 8996 7001. Email: membership@bsi-global.com.

Information regarding online access to British Standards via British Standards Online can be found at <http://www.bsi-global.com/bsonline>.

Further information about BSI is available on the BSI website at <http://www.bsi-global.com>.

Copyright

Copyright subsists in all BSI publications. BSI also holds the copyright, in the UK, of the publications of the international standardization bodies. Except as permitted under the Copyright, Designs and Patents Act 1988 no extract may be reproduced, stored in a retrieval system or transmitted in any form or by any means – electronic, photocopying, recording or otherwise – without prior written permission from BSI.

This does not preclude the free use, in the course of implementing the standard, of necessary details such as symbols, and size, type or grade designations. If these details are to be used for any other purpose than implementation then the prior written permission of BSI must be obtained.

Details and advice can be obtained from the Copyright & Licensing Manager. Tel: +44 (0)20 8996 7070. Fax: +44 (0)20 8996 7553. Email: copyright@bsi-global.com.