

Pigments and extenders — Methods of dispersion for assessment of dispersion characteristics —

Part 2: Dispersion using an oscillatory shaking machine

The European Standard EN ISO 8780-2:1995 has the status of a
British Standard

Committees responsible for this British Standard

The preparation of this British Standard was entrusted by the Pigments, Paints and Varnishes Standards Policy Committee (PVC/-) to Technical Committee PVC/1, upon which the following bodies were represented:

Aluminium Powder and Paste Association
 British Cement Association
 British Railways Board
 Chemical Industries' Association
 Oil and Colour Chemists Association
 Paintmakers Association of Great Britain Ltd
 Titanium Pigment Manufacturers Technical Committee
 Zinc Development Association

This British Standard, having been prepared under the direction of the Pigments, Paints and Varnishes Standards Policy Committee was published under the authority of the Standards Board and comes into effect on
 30 April 1991

© BSI 04-2000

The following BSI references relate to the work on this standard:
 Committee reference PVC/1
 Draft for comment 86/52354 DC

ISBN 0 580 19535 X

Amendments issued since publication

Amd. No.	Date	Comments
8529	August 1995	Indicated by a sideline in the margin

Contents

	Page
Committees responsible	Inside front cover
National foreword	ii
Foreword	2
Text of EN ISO 8780-2	3
Publication(s) referred to	Inside back cover

National foreword

This Part of BS 3483 has been prepared under the direction of the Pigments, Paints and Varnishes Standards Policy Committee. It is identical with ISO 8780-2:1990 "*Pigments and extenders — Methods of dispersion for assessment of dispersion characteristics — Part 2: Dispersion using an oscillatory shaking machine*", published by the International Organization for Standardization (ISO). It supersedes BS 3483-B5:1974, which is withdrawn.

In 1994 the European Committee for Standardization (CEN) accepted ISO 8780-2:1990 as European Standard EN ISO 8780-2:1995. As a consequence of implementing the European Standard this British Standard is renumbered as BS EN ISO 8780-2:1995 and any reference to BS 3483-D2 should be read as a reference to BS EN ISO 8780-2.

Cross-references

International Standard	Corresponding British Standard
ISO 842:1984	BS 4726:1986 <i>Methods for sampling raw materials for paints and varnishes</i> (Identical)
ISO 2431:1984	BS 3900 <i>Methods of test for paints</i> Part A6:1986 <i>Determination of flow time by use of flow cups</i> (Identical)
ISO 8780-1:1990	BS 3483 <i>Methods of testing pigments for paints</i> Part D1:1991 <i>Methods of dispersion for assessment of dispersion characteristics (Introduction)</i> (Identical)
ISO 8781-1:1990	Part E1:1991 <i>Assessment of dispersion characteristics from the change in tinting strength of coloured pigments</i> (Identical)
ISO 8781-2:1990	Part E2:1991 <i>Assessment of dispersion characteristics from the change in fineness of grind</i> (Identical)
ISO 8781-3:1990	Part E3:1991 <i>Assessment of dispersion characteristics from the change in gloss</i> (Identical)

The Technical Committee has reviewed the provisions of ISO 787-10:1981, to which reference is made in the text, and has decided that they are acceptable for use in conjunction with this standard. ISO 787-10 is related to BS 3483 "*Methods for testing pigments for paints*", Part B8:1982 "*Determination of density (pycnometer method)*".

A British Standard does not purport to include all the necessary provisions of a contract. Users of British Standards are responsible for their correct application.

Compliance with a British Standard does not of itself confer immunity from legal obligations.

Summary of pages

This document comprises a front cover, an inside front cover, pages i and ii, the EN ISO title page, pages 2 to 8, an inside back cover and a back cover.

This standard has been updated (see copyright date) and may have had amendments incorporated. This will be indicated in the amendment table on the inside front cover.

ICS 87.060.10

Descriptors: Paints, pigments, extenders, dispersibility, dispersing

English version

Pigments and extenders — Methods of dispersion for
assessment of dispersion characteristics —
Part 2: Dispersion using an oscillatory shaking machine

(ISO 8780-2:1990)

Pigments et matières de charge — Méthodes de
dispersion pour évaluer la dispersibilité —
Partie 2: Dispersion à l'aide d'une machine à
secousses
(ISO 8780-2:1990)

Pigmente und Füllstoffe —
Dispergiervverfahren zur Beurteilung des
Dispergierverhaltens —
Teil 2: Dispergieren mit einer
Schüttelmaschine
(ISO 8780-2:1990)

This European Standard was approved by CEN on 1994-10-17. CEN members are bound to comply with the CEN/CENELEC Internal Regulations which stipulate the conditions for giving this European Standard the status of a national standard without any alteration.

Up-to-date lists and bibliographical references concerning such national standards may be obtained on application to the Central Secretariat or to any CEN member.

This European Standard exists in three official versions (English, French, German). A version, in any other language made by translation under the responsibility of a CEN member into its own language and notified to the Central Secretariat has the same status as the official versions.

CEN members are the national standards bodies of Austria, Belgium, Denmark, Finland, France, Germany, Greece, Iceland, Ireland, Italy, Luxembourg, Netherlands, Norway, Portugal, Spain, Sweden, Switzerland and United Kingdom.

CEN

European Committee for Standardization
Comité Européen de Normalisation
Europäisches Komitee für Normung

Central Secretariat: rue de Stassart 36, B-1050 Brussels

Foreword

This European Standard has been taken over by the Technical Committee CEN/TC 298, Pigments and extenders, from the work of ISO/TC 35, Paints and varnishes, of the International Organization for Standardization (ISO).

This European Standard shall be given the status of a national standard, either by publication of an identical text or by endorsement, at the latest by September 1995, and conflicting national standards shall be withdrawn at the latest by September 1995.

According to the CEN/CENELEC Internal Regulations, the following countries are bound to implement this European Standard: Austria, Belgium, Denmark, Finland, France, Germany, Greece, Iceland, Ireland, Italy, Luxembourg, Netherlands, Norway, Portugal, Spain, Sweden, Switzerland and United Kingdom.

NOTE Normative references to international publications are given in Annex ZA (normative).

Contents

	Page
Foreword	2
1 Scope	3
2 Normative references	3
3 Required supplementary information	3
4 Apparatus	3
5 Binder system	4
6 Sampling	4
7 Mill base	4
7.1 Composition	4
7.2 Volume	5
8 Volume of grinding spheres	5
9 Procedure	5
9.1 Filling the containers	5
9.2 Dispersion	5
9.3 Stabilization	5
9.4 De-aeration	5
10 Test report	6
Annex A (normative) Required supplementary information	7
Annex ZA (normative) Normative references to international publications with their relevant European publications	8
Figure 1 — Holder	4

1 Scope

This part of ISO 8780 specifies a method for the dispersion of pigments and extenders using an oscillatory shaking machine. The method is suitable for the preparation of dispersions of several samples in the quality control of pigments. This part is for use in conjunction with the methods of assessment described in ISO 8781, using an agreed binder system of low viscosity. It should be read in conjunction with ISO 8780-1.

NOTE 1 The advantage of the oscillatory shaking method is that several batches of small amounts of mill base can be tested simultaneously in a closed system where solvent loss is minimized.

This method is restricted to low-viscosity mill bases allowing free movement of the grinding spheres (see 7.1). It is not suitable for optimizing mill base formulations for other dispersing techniques.

2 Normative references

The following standards contain provisions which, through reference in this text, constitute provisions of this part of ISO 8780. At the time of publication, the editions indicated were valid. All standards are subject to revision, and parties to agreements based on this part of ISO 8780 are encouraged to investigate the possibility of applying the most recent editions of the standards indicated below. Members of IEC and ISO maintain registers of currently valid International Standards.

ISO 787-10:1981, *General methods of test for pigments and extenders — Part 10: Determination of density — Pycnometer method.*

ISO 842:1984, *Raw materials for paints and varnishes — Sampling.*

ISO 2431:1984, *Paints and varnishes — Determination of flow time by use of flow cups.*

ISO 8780-1:1990, *Pigments and extenders — Methods of dispersion for assessment of dispersion characteristics — Part 1: Introduction.*

ISO 8781-1:1990, *Pigments and extenders — Methods of assessment of dispersion characteristics — Part 1: Assessment from the change in tinting strength of coloured pigments.*

ISO 8781-2:1990, *Pigments and extenders — Methods of assessment of dispersion characteristics — Part 2: Assessment from the change in fineness of grind.*

ISO 8781-3:1990, *Pigments and extenders — Methods of assessment of dispersion characteristics — Part 3: Assessment from the change in gloss.*

3 Required supplementary information

For any particular application, the test method specified in this part of 8780 needs to be completed by supplementary information. The items of supplementary information are given in Annex A.

4 Apparatus

Ordinary laboratory apparatus and glassware, together with the following:

4.1 Paint-conditioning machine, in which the containers are subjected to 680 to 690 reciprocating strokes per minute through a distance of 16 mm and an oscillatory action through an angle of $\pm 15^\circ$.

4.2 Holder, for several mill base containers, designed for fastening to the centre axis of the shaking machine in such a way that

- the centre point of each mill base container is 70 mm from the centre axis of the shaking machine;
- the top and bottom of each mill base container are at the same distance from a horizontal plane through the centre axis of the shaking machine;
- the mean time-weighted position of the containers is vertical.

The design shown in Figure 1 meets these requirements.

4.3 Containers, of a suitable type.

Containers for the mill bases shall be of the same size and type as those used for the agreed reference pigments.

Examples of suitable types are 250 ml glass or polyethylene bottles with screw caps lined with polyethylene inserts.

The size and type of container shall be agreed on and shall be recorded in the test report.

4.4 Grinding spheres, of a suitable type.

Spheres of the same size and type shall be used for all the mill bases under simultaneous test. The type, mean diameter and density shall be agreed on and shall be recorded in the test report.

If the spheres have never been used, they shall be conditioned by shaking them in a mill base (see 7.1), for example for 60 min, and cleaned.

NOTE 2 The diameter, density and total mass of the grinding spheres have a significant effect on the dispersion obtained. Glass spheres of a mean diameter of 3 mm + 0,5 mm and a density of 2,6 g/cm³ ± 0,2 g/cm³ have been found to be suitable.

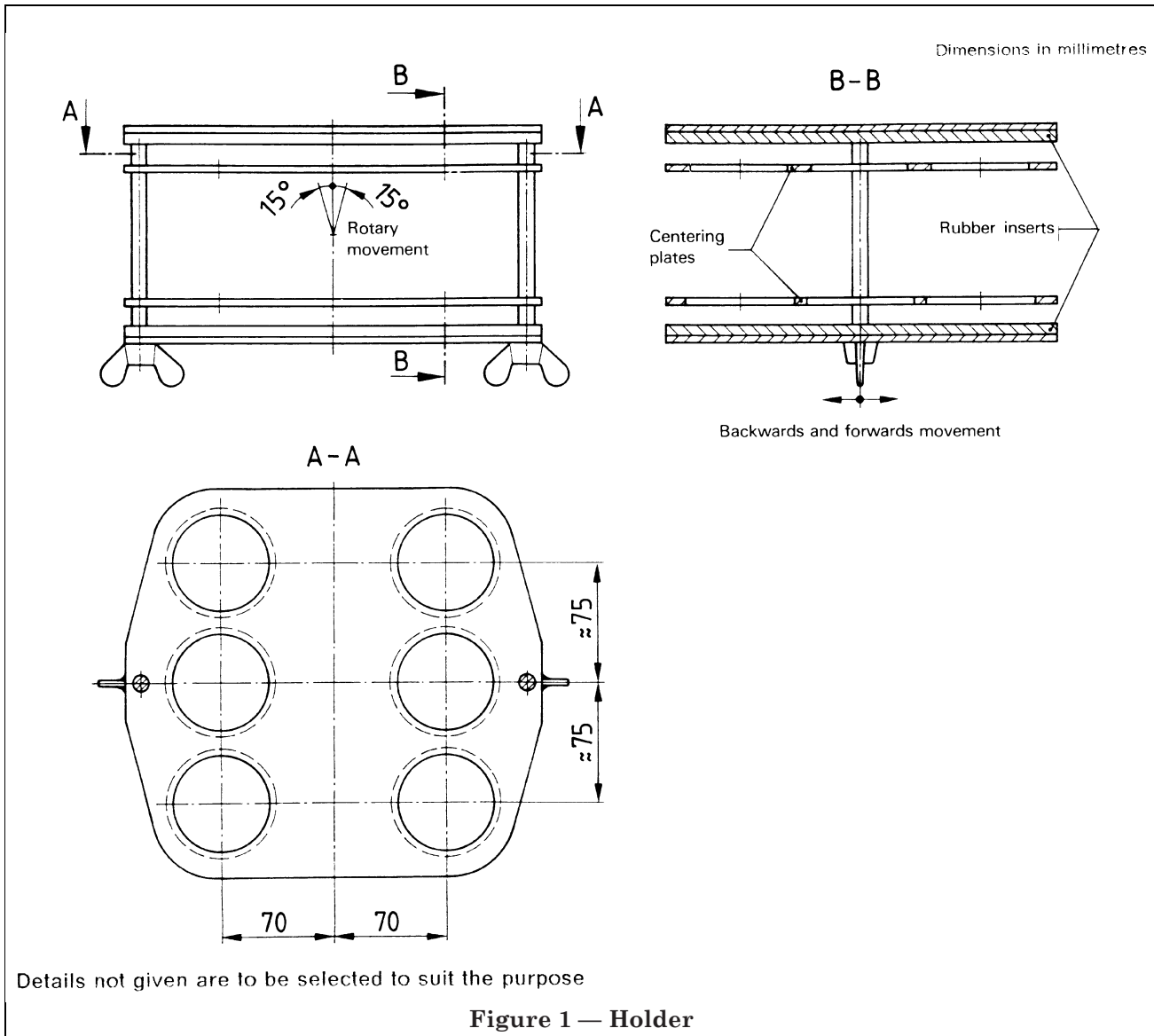

5 Binder system

The binder system shall be agreed on between the interested parties. The test report shall state the binder, the solvent and the concentration of the binder in the solvent, as well as giving information on the rheological properties (for example, viscosity or flow time) of the binder system.

The same batch of binder system shall be used for all tests in the same series.

6 Sampling

Take a representative sample of the product to be tested, as described in ISO 842.

7 Mill base

7.1 Composition

The viscosity of a mill base depends on the binder demand of the pigment and its concentration in a given binder system. Preliminary experiments shall therefore be carried out to ascertain a suitable mill base composition. The viscosity of the mill base during dispersion shall be such that the grinding spheres can move freely (see clause 1). This can be checked by shaking the containers manually.

For binder systems with flow times of 20 s to 40 s, determined with flow cup ISO 2431 No. 6, the following pigment concentrations have been found to be suitable as starting points:

- a) pigments of low binder demand — pigment concentration higher than 40 % (*m/m*);

- b) pigments of medium binder demand — pigment concentration 10 % (*m/m*) to 40 % (*m/m*);
- c) pigments of high binder demand — pigment concentration lower than 10 % (*m/m*).

7.2 Volume

The mill base shall occupy approximately 30 % of the volume of the container (4.3). The mass of the pigment and of the binder system may be determined by using the following equations:

Mass, m_p , of pigment, in grams:

$$m_p = \frac{0,3 \times V}{\frac{1}{\rho_p} + \frac{100 - PC}{\rho_M \times PC}}$$

Mass, m_M , of binder system, in grams:

$$m_M = \frac{m_p \times (100 - PC)}{PC}$$

where

- PC is the pigment concentration in the mill base, expressed as a percentage by mass;
- V is the volume, in millilitres, of the container (4.3);
- ρ_M is the density, in grams per cubic centimetre, of the binder system;
- ρ_p is the density, in grams per cubic centimetre, of the pigment, determined by one of the procedures described in ISO 787-10.

8 Volume of grinding spheres

The apparent volume of the grinding spheres (see note 2) shall be approximately 50 % of the total volume of the container. The same volume of grinding spheres shall be used in all tests in the same series.

9 Procedure

9.1 Filling the containers

Unless otherwise agreed or found advisable (see note 3), weigh the grinding spheres (4.4) into the container (4.3). Add the required mass of binder system (m_M), calculated in accordance with 7.2. Wet the grinding spheres with the binder system by tilting the container. Then add the required mass of pigment (m_p), calculated in accordance with 7.2. Close the container. Wet the pigment by carefully tilting the container.

NOTE 3 If it is difficult to wet the pigment, it may be advisable to select a different sequence of preparing the containers and, if necessary, the mill base may be placed in the container first and stirred with a spatula prior to the addition of the grinding spheres.

Complete the preparation of the full set of mill bases as quickly as possible in order to avoid differences in stirring or wetting time between the samples.

If the criterion for assessing the dispersion characteristics is to be the evaluation of the development of tinting strength (see ISO 8781-1), the masses of the pigment and of the binder system shall be determined to within 0,5 %. For other methods of assessment (for example fineness of grind, see ISO 8781-2, and change of gloss, see ISO 8781-3), wider tolerance ranges may be agreed on.

9.2 Dispersion

Immediately after the last mill base has been prepared, place the containers in the holder (4.2) and clamp the assembly in the paint-conditioning machine (4.1).

NOTE 4 The intensity of the shaking process depends on the loading of the holder. If repeatable dispersion results are to be obtained, particularly in the case of two-armed shaking machines, the holders should be equally loaded.

Take test portions of the dispersion after each of several (agreed) shaking times. At least four shaking times shall be selected from the following:

- pigments with poor ease of dispersion — 5 min, 10 min, 20 min, 40 min, 80 min, 160 min;
- pigments with high ease of dispersion — 1 min, 2 min, 4 min, 8 min, 16 min, 32 min.

The total mass of these test portions shall not exceed 15 % of the initial mass of the mill base. Otherwise make separate dispersions for each time interval.

9.3 Stabilization

If necessary, for example if the mill base is not stable enough, stabilize each test portion after its removal from the mill base by adding, for example, more binder and/or special additives. The procedure shall be agreed on between the interested parties.

9.4 De-aeration

If necessary, allow any air bubbles within the test portions to escape before proceeding to assess the dispersion. The means by which this is achieved, for example by allowing to stand for a few minutes, shall be agreed on between the interested parties.

10 Test report

The test report shall contain at least the following information:

- a) all details necessary to identify the product tested;
- b) a reference to this part of ISO 8780;
- c) the items of supplementary information referred to in Annex A;
- d) any deviation from the procedure specified;
- e) the date(s) of the test.

Annex A (normative)

Required supplementary information

The items of supplementary information listed in this annex shall be supplied as appropriate to enable the method to be carried out.

The information required should preferably be agreed between the interested parties and may be derived, in part or totally, from an international or national standard or other document related to the product under test.

- a) Type of machine (see **4.1**).
- b) Type of holder (see **4.2**).
- c) Type and size of container (see **4.3**).
- d) Type, mean diameter, density and total mass of the grinding spheres (see **4.4**).
- e) Binder system (see clause **5**)
- f) Composition of the mill base (see **7.1**).
- g) Shaking times (see **9.2**).
- h) Stabilization procedure (see **9.3**)
- i) De-aeration procedure (see **9.4**).

Annex ZA (normative)**Normative references to international publications with their relevant European publications**

This European Standard incorporates by dated or undated reference, provisions from other publications. These normative references are cited at the appropriate places in the text and the publications are listed hereafter. For dated references, subsequent amendments to or revisions of any of these publications apply to this European Standard only when incorporated in it by amendment or revision. For undated references the latest edition of the publication referred to applies (including amendments).

Publication	Year	Title	EN	Year
ISO 8781-1	1990	<i>Pigments and extenders — Methods of assessment of dispersion characteristics Part 1: Assessment from the change in tinting strength of coloured pigments</i>	EN ISO 8781-1	1995
ISO 8781-2	1990	<i>Pigments and extenders — Methods of assessment of dispersion characteristics Part 2: Assessment from the change in fineness of grind</i>	EN ISO 8781-2	1995
ISO 8781-3	1990	<i>Pigments and extenders — Methods of assessment of dispersion characteristics Part 3: Assessment from the change in gloss</i>	EN ISO 8781-3	1995
ISO 8780-1	1990	<i>Pigments and extenders — Methods of dispersion for assessment of dispersion characteristics Part 1: Introduction</i>	EN ISO 8780-1	1995

Publication(s) referred to

See national foreword.

BSI — British Standards Institution

BSI is the independent national body responsible for preparing British Standards. It presents the UK view on standards in Europe and at the international level. It is incorporated by Royal Charter.

Revisions

British Standards are updated by amendment or revision. Users of British Standards should make sure that they possess the latest amendments or editions.

It is the constant aim of BSI to improve the quality of our products and services. We would be grateful if anyone finding an inaccuracy or ambiguity while using this British Standard would inform the Secretary of the technical committee responsible, the identity of which can be found on the inside front cover. Tel: 020 8996 9000. Fax: 020 8996 7400.

BSI offers members an individual updating service called PLUS which ensures that subscribers automatically receive the latest editions of standards.

Buying standards

Orders for all BSI, international and foreign standards publications should be addressed to Customer Services. Tel: 020 8996 9001. Fax: 020 8996 7001.

In response to orders for international standards, it is BSI policy to supply the BSI implementation of those that have been published as British Standards, unless otherwise requested.

Information on standards

BSI provides a wide range of information on national, European and international standards through its Library and its Technical Help to Exporters Service. Various BSI electronic information services are also available which give details on all its products and services. Contact the Information Centre. Tel: 020 8996 7111. Fax: 020 8996 7048.

Subscribing members of BSI are kept up to date with standards developments and receive substantial discounts on the purchase price of standards. For details of these and other benefits contact Membership Administration. Tel: 020 8996 7002. Fax: 020 8996 7001.

Copyright

Copyright subsists in all BSI publications. BSI also holds the copyright, in the UK, of the publications of the international standardization bodies. Except as permitted under the Copyright, Designs and Patents Act 1988 no extract may be reproduced, stored in a retrieval system or transmitted in any form or by any means – electronic, photocopying, recording or otherwise – without prior written permission from BSI.

This does not preclude the free use, in the course of implementing the standard, of necessary details such as symbols, and size, type or grade designations. If these details are to be used for any other purpose than implementation then the prior written permission of BSI must be obtained.

If permission is granted, the terms may include royalty payments or a licensing agreement. Details and advice can be obtained from the Copyright Manager. Tel: 020 8996 7070.