

Grooved pins — Half-length taper grooved

The European Standard EN ISO 8745:1997 has the status of a
British Standard

ICS 21.060.50

Confirmed
May 2008

National foreword

This British Standard is the English language version of EN ISO 8745:1997. It is identical with ISO 8745:1997. It supersedes BS EN 28745:1992 which is withdrawn.

The UK participation in its preparation was entrusted by Technical Committee FME/9, Bolts, nuts and accessories, to Subcommittee FME/9/6, General purpose fasteners and accessories, which has the responsibility to:

- aid enquirers to understand the text;
- present to the responsible international/European committee any enquiries on the interpretation, or proposals for change, and keep the UK interests informed;
- monitor related international and European developments and promulgate them in the UK.

A list of organizations represented on this subcommittee can be obtained on request to its secretary.

Cross-references

Attention is drawn to the fact that CEN and CENELEC standards normally include an annex which lists normative references to international publications with their corresponding European publications. The British Standards which implement international or European publications referred to in this document may be found in the BSI Standards Catalogue under the section entitled “International Standards Correspondence Index”, or by using the “Find” facility of the BSI Standards Electronic Catalogue.

A British Standard does not purport to include all the necessary provisions of a contract. Users of British Standards are responsible for their correct application.

Compliance with a British Standard does not of itself confer immunity from legal obligations.

Summary of pages

This document comprises a front cover, an inside front cover, pages i and ii, the EN ISO title page, page 2, the ISO title page, page ii, pages 1 to 4, an inside back cover and a back cover.

This standard has been updated (see copyright date) and may have had amendments incorporated. This will be indicated in the amendment table on the inside front cover.

This British Standard, having been prepared under the direction of the Engineering Sector Board, was published under the authority of the Standards Board and comes into effect on 15 May 1998

© BSI 04-1999

ISBN 0 580 29060 3

Amendments issued since publication

Amd. No.	Date	Comments

Contents

	Page
National foreword	Inside front cover
Foreword	2
Foreword	ii
Text of ISO 8745:1997	1

Descriptors: See ISO document

English version

Grooved pins – Half-length taper grooved

(ISO 8745:1997)

Goupilles cannelées à cannelures progressives Paßkerbstifte (ISO 8745:1997)
sur la moitié de la longueur (débouchantes)
(ISO 8745:1997)

This European Standard was approved by CEN on 23 October 1997.

CEN members are bound to comply with the CEN/CENELEC Internal Regulations which stipulate the conditions for giving this European Standard the status of a national standard without any alteration. Up-to-date lists and bibliographical references concerning such national standards may be obtained on application to the Central Secretariat or to any CEN member.

This European Standard exists in three official versions (English, French, German). A version in any other language made by translation under the responsibility of a CEN member into its own language and notified to the Central Secretariat has the same status as the official versions.

CEN members are the national standards bodies of Austria, Belgium, Czech Republic, Denmark, Finland, France, Germany, Greece, Iceland, Ireland, Italy, Luxembourg, Netherlands, Norway, Portugal, Spain, Sweden, Switzerland and United Kingdom.

CEN

European Committee for Standardization
Comité Européen de Normalisation
Europäisches Komitee für Normung

Central Secretariat: rue de Stassart 36, B-1050 Brussels

Foreword

The text of the International Standard ISO 8745:1997 has been prepared by Technical Committee ISO/TC 2 “Fasteners” in collaboration with Technical Committee CEN/TC 185 “Threaded and non-threaded mechanical fasteners and accessories”, the secretariat of which is held by DIN.

This European Standard supersedes EN 28745:1992.

This European Standard shall be given the status of a national standard, either by publication of an identical text or by endorsement, at the latest by May 1998, and conflicting national standards shall be withdrawn at the latest by May 1998.

According to the CEN/CENELEC Internal Regulations, the national standards organizations of the following countries are bound to implement this European Standard: Austria, Belgium, Czech Republic, Denmark, Finland, France, Germany, Greece, Iceland, Ireland, Italy, Luxembourg, Netherlands, Norway, Portugal, Spain, Sweden, Switzerland and the United Kingdom.

Endorsement notice

The text of the International Standard ISO 8745:1997 has been approved by CEN as a European Standard without any modifications.

NOTE Normative references to International Standards are listed in Annex ZA (normative).

Contents

	Page
Foreword	1
1 Scope	1
2 Normative references	1
3 Dimensions	1
4 Application	3
5 Requirements and reference International Standards	3
6 Designation	4
Annex ZA (normative) Normative references to international publications with their relevant European publication	Inside back cover
Figure 1	1
Table 1 — Dimensions	2
Table 2 — Requirements and reference International Standards	3

INTERNATIONAL
STANDARD

ISO
8745

Second edition
1997-11-15

Grooved pins — Half-length taper grooved

*Goupilles cannelées à cannelures progressives sur la moitié de la longueur
(débochantes)*



Reference number
ISO 8745:1997(E)

Foreword

ISO (the International Organization for Standardization) is a worldwide federation of national standards bodies (ISO member bodies). The work of preparing International Standards is normally carried out through ISO technical committees. Each member body interested in a subject for which a technical committee has been established has the right to be represented on that committee. International organizations, governmental and non-governmental, in liaison with ISO, also take part in the work. ISO collaborates closely with the International Electrotechnical Commission (IEC) on all matters of electrotechnical standardization.

Draft International Standards adopted by the technical committees are circulated to the member bodies for voting. Publication as an International Standard requires approval by at least 75 % of the member bodies casting a vote.

International Standard ISO 8745 was prepared by Technical Committee ISO/TC 2, *Fasteners*.

This second edition cancels and replaces the first edition (ISO 8745:1986), which has been technically revised.

Descriptors: Fasteners, steel products, pins (mechanics), grooved pins, specifications, characteristics, dimensions, designation.

1 Scope

This International Standard specifies the characteristics of half-length taper grooved pins made of steel or austenitic stainless steel which have three equally spaced grooves impressed longitudinally on their exterior surface, with nominal diameter, d_1 , from 1,5 mm to 25 mm inclusive.

The displaced material to each side of the grooves forming an expanded diameter, d_2 , which is larger than the nominal diameter d_1 will cause a non-positive locking fit when these grooved pins are forced into a drilled hole equal to the nominal diameter d_1 , (see clause 4).

2 Normative references

The following standards contain provisions which, through reference in this text, constitute provisions of this International Standard. At the time of publication, the editions indicated were valid. All standards are subject to revision, and parties to agreements based on this International Standard are encouraged to investigate the possibility of applying the most recent editions of the standards indicated below. Members of IEC and ISO maintain registers of currently valid International Standards.

ISO 3269:1988, *Fasteners — Acceptance inspection*.

ISO 3506-1:1997, *Corrosion-resistant stainless steel fasteners — Part 1: Bolts, screws and studs*.

ISO 4042:—¹⁾, *Fasteners — Electroplated coatings*.

ISO 8749:1986, *Pins and grooved pins — Shear test*.

ISO 9717:1990, *Phosphate conversion coatings for metals — Method of specifying requirements*.

3 Dimensions

See Figure 1 and Table 1.

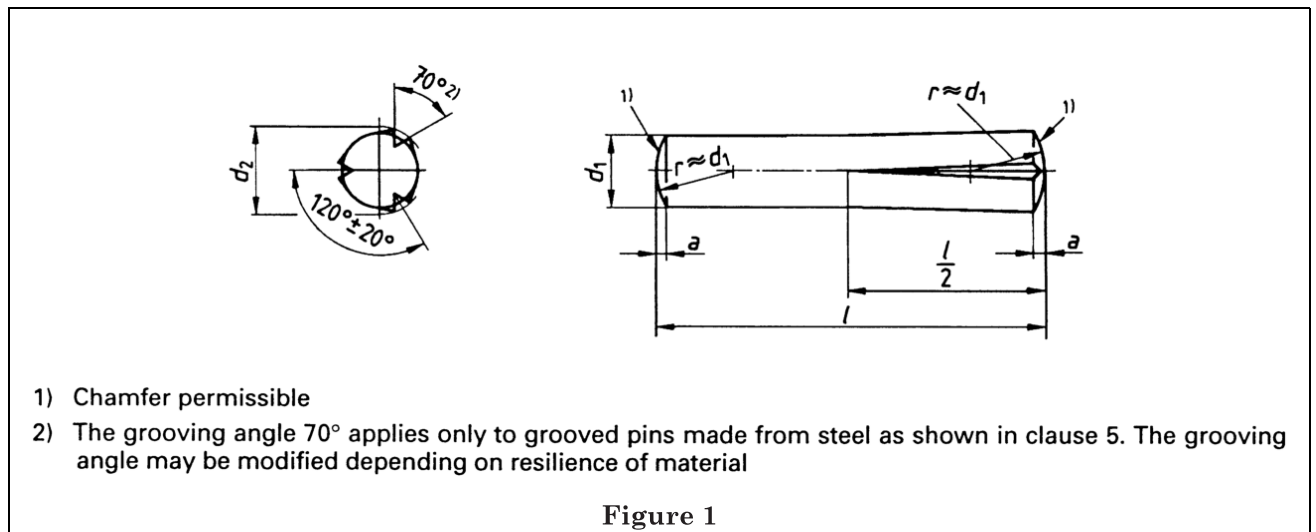

¹⁾ To be published. (Revision of ISO 4042:1989)

Table 1 — Dimensions

Dimensions in millimetres

d_1		nom.	1,5	2	2,5	3	4	5	6	8	10	12	16	20	25
		tol.	h9				h11								
a		\approx	0,2	0,25	0,3	0,4	0,5	0,63	0,8	1	1,2	1,6	2	2,5	3
Minimum shear strength, double ^a kN			1,6	2,84	4,4	6,4	11,3	17,6	25,4	45,2	70,4	101,8	181	283	444
l^b			Expanded diameter, $d_2^{c, d}$												
nom.	min.	max.	+ 0,05 0	± 0,05						± 0,1					
8	7,75	8,25	1,63	2,15	2,65	3,2	4,25	5,25	6,25	8,25	10,3	12,3	16,5	20,55	25,5
10	9,75	10,25													
12	11,5	12,5													
14	13,5	14,5	2,7	3,3	4,3	5,3	6,3	8,3	10,35	12,35	16,55	20,6	25,6		
16	15,5	16,5													
18	17,5	18,5													
20	19,5	20,5	4,3	5,3	6,3	8,35	10,4	12,4	16,6	20,6	25,6				
22	21,5	22,5													
24	23,5	24,5													
26	25,5	26,5	4,3	5,3	6,3	8,4	10,45	12,45	16,6	20,6	25,6				
28	27,5	28,5													
30	29,5	30,5													
32	31,5	32,5	4,3	5,3	6,3	8,4	10,45	12,45	16,6	20,6	25,6				
35	34,5	35,5													
40	39,5	40,5													
45	44,5	45,5	4,3	5,3	6,3	8,4	10,45	12,45	16,6	20,6	25,6				
50	49,5	50,5													
55	54,25	55,75													
60	59,25	60,75	4,3	5,3	6,3	8,4	10,45	12,45	16,6	20,6	25,6				
65	64,25	65,75													
70	69,25	70,75													
75	74,25	75,75	4,3	5,3	6,3	8,4	10,45	12,45	16,6	20,6	25,6				
80	79,25	80,75													
85	84,25	85,75													
90	89,25	90,75	4,3	5,3	6,3	8,4	10,45	12,45	16,6	20,6	25,6				
95	94,25	95,75													
100	99,25	100,75													
120	119,25	120,75	4,3	5,3	6,3	8,4	10,45	12,45	16,6	20,6	25,6				
140	139,25	140,75													
160	159,25	160,75													
180	179,25	180,75	4,3	5,3	6,3	8,4	10,45	12,45	16,6	20,6	25,6				
200	199,25	200,75													

^a Applies only to grooved pins made from steel as shown in clause 5.

^b The range of commercial lengths is between the stepped lines.

^c The expanded diameter d_2 applies only to pins made from steel as shown in clause 5. For other materials, for example stainless steel, a reduction amount shall be subtracted from the given values and should be agreed between customer and supplier.

^d For testing d_2 , a GO/NO GO ring gauge should be used.

4 Application

The diameter of the hole into which the groove pin is to be inserted shall be equal to the nominal diameter d_1 of the mating pin and to tolerance class H11.

5 Requirements and reference International Standards

See Table 2.

Table 2 — Requirements and reference International Standards

Material^a	Steel (St)	Austenitic stainless steel
	Hardness 125 HV30 to 245 HV30	A1 in accordance with ISO 3506-1, hardness 210 HV30 to 280 HV30
Grooves	Form of groove at the discretion of the supplier.	
Surface finish	Plain, i.e. pins to be supplied in natural finish treated with a protective lubricant, unless otherwise specified by agreement between customer and supplier.	Plain, i.e. pins to be supplied in natural finish.
	Preferred coatings are black oxide, phosphate coating or zinc plating with chromate conversion coating (see ISO 9717 and ISO 4042). Other coatings as agreed between customer and supplier. All tolerances shall apply prior to the application of a plating or coating.	
Workmanship	Pins shall be free of irregularities or detrimental defects.	
Shear strength test	The test shall be in accordance with ISO 8749.	
Acceptability	The acceptance procedure is covered in ISO 3269.	
^a Other materials as agreed between customer and supplier.		

6 Designation

EXAMPLE 1

A half-length taper grooved steel pin with nominal diameter $d_1 = 6$ mm and nominal length $l = 50$ mm is designated as follows:

Grooved pin ISO 8745 – 6 × 50 – St

EXAMPLE 2

A half-length taper grooved austenitic stainless steel pin of grade A1, with nominal diameter $d_1 = 6$ mm and nominal length $l = 50$ mm is designated as follows:

Grooved pin ISO 8745 – 6 × 50 – A1

Annex ZA (normative)**Normative references to international publications with their relevant European publications**

This European Standard incorporates by dated or undated reference, provisions from other publications. These normative references cited at the appropriate places in the text and the publications are listed hereafter. For dated references, subsequent amendments to or revisions of any of these publications apply to this European Standard only when incorporated in it by amendment or revision. For undated references the latest edition of the publication referred to applies.

<u>Publication</u>	<u>Year</u>	<u>Title</u>	<u>EN</u>	<u>Year</u>
ISO 8749	1986	Pins and grooved pins — Shear test	EN 28749	1992
ISO 3506-1	1997	Mechanical properties of corrosion-resistant stainless steel fasteners — Part 1: Bolts, screws and studs	EN ISO 3506-1	1997

BSI — British Standards Institution

BSI is the independent national body responsible for preparing British Standards. It presents the UK view on standards in Europe and at the international level. It is incorporated by Royal Charter.

Revisions

British Standards are updated by amendment or revision. Users of British Standards should make sure that they possess the latest amendments or editions.

It is the constant aim of BSI to improve the quality of our products and services. We would be grateful if anyone finding an inaccuracy or ambiguity while using this British Standard would inform the Secretary of the technical committee responsible, the identity of which can be found on the inside front cover.
Tel: 020 8996 9000. Fax: 020 8996 7400.

BSI offers members an individual updating service called PLUS which ensures that subscribers automatically receive the latest editions of standards.

Buying standards

Orders for all BSI, international and foreign standards publications should be addressed to Customer Services. Tel: 020 8996 9001. Fax: 020 8996 7001.

In response to orders for international standards, it is BSI policy to supply the BSI implementation of those that have been published as British Standards, unless otherwise requested.

Information on standards

BSI provides a wide range of information on national, European and international standards through its Library and its Technical Help to Exporters Service. Various BSI electronic information services are also available which give details on all its products and services. Contact the Information Centre.
Tel: 020 8996 7111. Fax: 020 8996 7048.

Subscribing members of BSI are kept up to date with standards developments and receive substantial discounts on the purchase price of standards. For details of these and other benefits contact Membership Administration.
Tel: 020 8996 7002. Fax: 020 8996 7001.

Copyright

Copyright subsists in all BSI publications. BSI also holds the copyright, in the UK, of the publications of the international standardization bodies. Except as permitted under the Copyright, Designs and Patents Act 1988 no extract may be reproduced, stored in a retrieval system or transmitted in any form or by any means – electronic, photocopying, recording or otherwise – without prior written permission from BSI.

This does not preclude the free use, in the course of implementing the standard, of necessary details such as symbols, and size, type or grade designations. If these details are to be used for any other purpose than implementation then the prior written permission of BSI must be obtained.

If permission is granted, the terms may include royalty payments or a licensing agreement. Details and advice can be obtained from the Copyright Manager.
Tel: 020 8996 7070.