

# Milk based infant foods — Determination of fat content — Gravimetric method (Reference method)

The European Standard EN ISO 8381:2000 has the status of a  
British Standard

ICS 67.230

## National foreword

This British Standard is the official English language version of EN ISO 8381:2000. It is identical with ISO 8381:1999. It supersedes BS 7142-1:1989 which is withdrawn.

The UK participation in its preparation was entrusted to Technical Committee AW/5, Chemical analysis of milk and milk products, which has the responsibility to:

- aid enquirers to understand the text;
- present to the responsible international/European committee any enquiries on the interpretation, or proposals for change, and keep the UK interests informed;
- monitor related international and European developments and promulgate them in the UK.

A list of organizations represented on this committee can be obtained on request to its secretary.

### Cross-references

Attention is drawn to the fact that CEN and CENELEC Standards normally include an annex which lists normative references to international publications with their corresponding European publications. The British Standards which implement these international or European publications may be found in the BSI Standards Catalogue under the section entitled "International Standards Correspondence Index", or by using the "Find" facility of the BSI Standards Electronic Catalogue.

A British Standard does not purport to include all the necessary provisions of a contract. Users of British Standards are responsible for their correct application.

**Compliance with a British Standard does not of itself confer immunity from legal obligations.**

### Summary of pages

This document comprises a front cover, an inside front cover, the EN ISO title page, the EN ISO foreword page, the ISO title page, pages ii to iv, pages 1 to 15 and a back cover.

The BSI copyright notice displayed in this document indicates when the document was last issued.

This British Standard, having been prepared under the direction of the Sector Committee for Building and Civil Engineering, was published under the authority of the Standards Committee and comes into effect on 15 June 2000

© BSI 06-2000

### Amendments issued since publication

Amd. No.	Date	Comments

ICS 67.100.01

English version

**Milk-based infant foods - Determination of fat content -  
Gravimetric method (Reference method) (ISO 8381:2000)**

Aliments à base de lait pour enfants en bas âge -  
Détermination de la teneur en matière grasse - Méthode  
gravimétrique (Méthode de référence) (ISO 8381:2000)

Säuglingsnahrung auf Milchbasis - Bestimmung des  
Fettgehaltes - Gravimetrisches Verfahren  
(Referenzverfahren) (ISO 8381:2000)

This European Standard was approved by CEN on 24 December 1999.

CEN members are bound to comply with the CEN/CENELEC Internal Regulations which stipulate the conditions for giving this European Standard the status of a national standard without any alteration. Up-to-date lists and bibliographical references concerning such national standards may be obtained on application to the Central Secretariat or to any CEN member.

This European Standard exists in three official versions (English, French, German). A version in any other language made by translation under the responsibility of a CEN member into its own language and notified to the Central Secretariat has the same status as the official versions.

CEN members are the national standards bodies of Austria, Belgium, Czech Republic, Denmark, Finland, France, Germany, Greece, Iceland, Ireland, Italy, Luxembourg, Netherlands, Norway, Portugal, Spain, Sweden, Switzerland and United Kingdom.



EUROPEAN COMMITTEE FOR STANDARDIZATION  
COMITÉ EUROPÉEN DE NORMALISATION  
EUROPÄISCHES KOMITEE FÜR NORMUNG

**Central Secretariat: rue de Stassart, 36 B-1050 Brussels**

**Foreword**

The text of the International Standard ISO 8381:2000 has been prepared by Technical Committee ISO/TC 34 "Agricultural food products" in collaboration with Technical Committee CEN/TC 302 "Milk and milk products - Methods of sampling and analysis", the secretariat of which is held by NNI.

This European Standard shall be given the status of a national standard, either by publication of an identical text or by endorsement, at the latest by September 2000, and conflicting national standards shall be withdrawn at the latest by September 2000.

According to the CEN/CENELEC Internal Regulations, the national standards organizations of the following countries are bound to implement this European Standard: Austria, Belgium, Czech Republic, Denmark, Finland, France, Germany, Greece, Iceland, Ireland, Italy, Luxembourg, Netherlands, Norway, Portugal, Spain, Sweden, Switzerland and the United Kingdom.

**Endorsement notice**

The text of the International Standard ISO 8381:2000 was approved by CEN as a European Standard without any modification.

INTERNATIONAL  
STANDARD

**ISO**  
**8381**

Second edition  
2000-03-01

---

---

**Milk-based infant foods — Determination of  
fat content — Gravimetric method  
(Reference method)**

*Aliments à base de lait pour enfants en bas âge — Détermination de la  
teneur en matière grasse — Méthode gravimétrique (Méthode de  
référence)*



Reference number  
ISO 8381:2000(E)



## Contents

Page

Foreword.....	iv
1 Scope .....	1
2 Normative reference .....	1
3 Term and definition .....	1
4 Principle .....	2
5 Reagents.....	2
6 Apparatus .....	2
7 Sampling.....	3
8 Preparation of test sample.....	4
8.1 Liquid products.....	4
8.2 Viscous or pasty products.....	4
8.3 Dried products .....	4
9 Procedure .....	4
9.1 Test portion .....	4
9.2 Blank tests.....	4
9.3 Preparation of fat-collecting vessel .....	5
9.4 Determination.....	5
10 Calculation and expression of results.....	7
10.1 Calculation.....	7
10.2 Expression of results .....	8
11 Precision.....	8
11.1 Interlaboratory test .....	8
11.2 Repeatability.....	8
11.3 Reproducibility.....	8
12 Test report .....	9
Annex A (informative) Notes on procedures.....	10
Annex B (informative) Alternative procedure using fat-extraction tubes with siphon or wash-bottle fittings .....	12
Bibliography .....	15

## **Foreword**

ISO (the International Organization for Standardization) is a worldwide federation of national standards bodies (ISO member bodies). The work of preparing International Standards is normally carried out through ISO technical committees. Each member body interested in a subject for which a technical committee has been established has the right to be represented on that committee. International organizations, governmental and non-governmental, in liaison with ISO, also take part in the work. ISO collaborates closely with the International Electrotechnical Commission (IEC) on all matters of electrotechnical standardization.

International Standards are drafted in accordance with the rules given in the ISO/IEC Directives, Part 3.

Draft International Standards adopted by the technical committees are circulated to the member bodies for voting. Publication as an International Standard requires approval by at least 75 % of the member bodies casting a vote.

Attention is drawn to the possibility that some of the elements of this International Standard may be the subject of patent rights. ISO shall not be held responsible for identifying any or all such patent rights.

International Standard ISO 8381 was prepared by Technical Committee ISO/TC 34, *Agricultural food products*, Subcommittee SC 5, *Milk and milk products*, in collaboration with the International Dairy Federation (IDF) and AOAC International, and will also be published by these organizations.

This second edition cancels and replaces the first edition (ISO 8381:1987), which has been technically revised.

Annexes A and B of this International Standard are for information only.



# Milk-based infant foods — Determination of fat content — Gravimetric method (Reference method)

**WARNING** — The use of this International Standard may involve hazardous materials, operations and equipment. This standard does not purport to address all the safety problems associated with its use. It is the responsibility of the user of this standard to establish safety and health practices and determine the applicability of regulatory limitations prior to use.

## 1 Scope

This International Standard specifies the reference method for the determination of the fat content of milk-based infant foods.

The method is applicable to liquid, concentrated and dried milk-based infant foods with no, or not more than a mass fraction of 5 % (dry matter) of starch or dextrin, or vegetable, fruit, meat, etc.

NOTE 1 Malto-dextrins without higher molecular mass dextrins, which are often present in infant foods, do not disturb the Röse-Gottlieb extraction even when present in high concentrations.

The method is not applicable to products which do not dissolve completely in ammonia owing to the presence of more than a few percent of starch or dextrin, or to the presence of hard lumps. The method is also not applicable to products which contains free fatty acids in significant quantities. The results obtained for these products will be too low.

NOTE 2 For such products, recourse should be made to a method utilizing the Weibull-Berntrop principle (see ISO 8262-1).

## 2 Normative reference

The following normative document contains provisions which, through reference in this text, constitute provisions of this International Standard. For dated references, subsequent amendments to, or revisions of, this publication do not apply. However, parties to agreements based on this International Standard are encouraged to investigate the possibility of applying the most recent editions of the normative document indicated below. For undated references, the latest edition of the normative document referred to applies. Members of ISO and IEC maintain registers of currently valid International Standards.

ISO 3889, *Milk and milk products — Determination of fat content — Mojonnier-type fat extraction flasks.*

## 3 Term and definition

For the purposes of this International Standard, the following term and definition apply.

### 3.1

#### **fat content of milk**

mass fraction of substances determined by the procedure specified in this International Standard

NOTE The fat content is expressed as a mass fraction, in percent [formerly given as % (*m/m*)].

## 4 Principle

An ammoniacal ethanolic solution of a test portion is extracted with diethyl ether and light petroleum. The solvents are removed by distillation or evaporation. The mass of the substances extracted is determined.

NOTE This is usually known as the Röse-Gottlieb principle.

## 5 Reagents

Use only reagents of recognized analytical grade, unless otherwise specified, and distilled or demineralized water or water of equivalent purity.

The reagents shall leave no appreciable residue when the determination is carried out by the method specified (see 9.2.2).

**5.1 Ammonia solution**, containing a mass fraction of  $\text{NH}_3$  of approximately 25 % ( $\rho_{20} = 910 \text{ g/l}$ ).

NOTE If ammonia solution of this concentration is not available, a more concentrated solution of known concentration may be used (see 9.4.2).

**5.2 Ethanol** ( $\text{C}_2\text{H}_5\text{OH}$ ), or ethanol denatured by methanol, containing a volume fraction of ethanol of at least 94 %. (See A.5.)

**5.3 Congo red solution**

Dissolve 1 g of Congo red in water in a 100 ml one-mark volumetric flask (6.14). Dilute to the mark with water.

NOTE The use of this solution, which allows the interface between the solvent and aqueous layers to be seen more clearly, is optional (see 9.4.4). Other aqueous colour solutions may be used provided that they do not affect the result of the determination.

**5.4 Diethyl ether** ( $\text{C}_2\text{H}_5\text{OC}_2\text{H}_5$ ), free from peroxides (see A.3), containing no more than 2 mg/kg of antioxidants, and complying with the requirements for the blank test (see 9.2.2, A.1 and A.4).

NOTE The use of diethyl ether could lead to hazardous situations. Due to expected changes in safety regulations studies are ongoing to replace diethyl ether by another reagent provided that it does not affect the end result of the determination.

**5.5 Light petroleum**, with any boiling range between 30 °C and 60 °C or, as equivalent, **pentane** ( $\text{CH}_3[\text{CH}_2]_3\text{CH}_3$ ) with a boiling point of 36 °C and complying with the requirements for the blank test (see 9.2.2, A.1 and A.4).

NOTE The use of pentane is recommended because of its higher purity and constant quality.

**5.6 Mixed solvent**

Shortly before use, mix equal volumes of diethyl ether (5.4) and light petroleum (5.5).

## 6 Apparatus

**WARNING** — Since the determination involves the use of volatile flammable solvents, all electrical apparatus employed shall comply with legislation relating to the hazards in using such solvents.

Usual laboratory equipment and, in particular, the following.

**6.1 Analytical balance**, capable of weighing to the nearest 1 mg, with a readability of 0,1 mg.

**6.2 Centrifuge**, capable of holding the fat-extraction flasks or tubes (6.6) and capable of spinning at a rotational frequency of  $500 \text{ min}^{-1}$  to  $600 \text{ min}^{-1}$  to produce a radial acceleration of  $80 g$  to  $90 g$  at the outer end of the flasks or tubes.

NOTE The use of the centrifuge is optional but recommended (see 9.4.7).

**6.3 Distillation or evaporation apparatus**, for distilling the solvents and ethanol from the boiling or conical flasks, or evaporating from beakers and dishes (see 9.4.14) at a temperature not exceeding  $100 \text{ }^\circ\text{C}$ .

**6.4 Drying oven**, electrically heated, with ventilation port(s) fully open, capable of being maintained at a temperature of  $102 \text{ }^\circ\text{C} \pm 2 \text{ }^\circ\text{C}$  throughout its working space.

The oven shall be fitted with a suitable thermometer.

**6.5 Water baths**, capable of being maintained at temperatures of between  $30 \text{ }^\circ\text{C}$  and  $40 \text{ }^\circ\text{C}$ ,  $40 \text{ }^\circ\text{C}$  and  $60 \text{ }^\circ\text{C}$ , and  $60 \text{ }^\circ\text{C}$  and  $70 \text{ }^\circ\text{C}$ .

**6.6 Mojonnier-type fat-extraction flasks**, as specified in ISO 3889.

NOTE It is also possible to use fat-extraction tubes, with siphon or wash-bottle fittings, but then the procedure is different. The alternative procedure is given in annex B.

The fat-extraction flasks shall be provided with good quality bark corks or stoppers of other material [e.g. silicone rubber or polytetrafluoroethylene (PTFE)] unaffected by the reagents used. Bark corks shall be extracted with the diethyl ether (5.4), kept in water at a temperature of  $60 \text{ }^\circ\text{C}$  or more for at least 15 min, and shall then be allowed to cool in the water so that they are saturated when used.

**6.7 Rack**, for holding the fat-extraction flasks (or tubes) (6.6).

**6.8 Wash bottle**, suitable for use with the mixed solvent (5.6).

A plastics wash bottle shall not be used.

**6.9 Fat-collecting vessels**, such as boiling flasks (flat-bottomed), of capacities 125 ml to 250 ml, conical flasks, of capacity 250 ml, or metal dishes.

If metal dishes are used, they shall be of stainless steel, flat-bottomed with a diameter of 80 mm to 100 mm and a height of approximately 50 mm.

**6.10 Boiling aids**, fat-free, of non-porous porcelain or silicon carbide (optional when metal dishes are used).

**6.11 Measuring cylinders**, of capacities 5 ml and 25 ml.

**6.12 Pipettes**, graduated, of capacity 10 ml.

**6.13 Tongs**, made of metal, for holding flasks, beakers or dishes.

**6.14 Volumetric flask**, one-mark, of capacity 100 ml.

## 7 Sampling

Sampling is not part of the method specified in this International Standard. A recommended sampling method is given in ISO 707.

It is important that the laboratory receive a sample which is truly representative and has not been damaged or changed during transport or storage.

Store all liquid, viscous or pasty samples at a temperature of between  $2 \text{ }^\circ\text{C}$  and  $6 \text{ }^\circ\text{C}$  from the time of sampling to the time of commencing the procedure. In the case of samples in sealed cans or bottles, store these samples unopened at a temperature below  $20 \text{ }^\circ\text{C}$ .

## **8 Preparation of test sample**

### **8.1 Liquid products**

Shake and invert the sample container. Open the container to pour the product slowly into a second sample container provided with an airtight lid. Mix by repeated transfer the product, taking care to incorporate in the sample any fat or other constituent adhering to the wall and ends of the first container. Transfer the test sample as completely as possible to the second sample container. Close this container.

If necessary, condition the unopened sample container in the water bath (6.5) set at between 40 °C and 60 °C. Remove and shake the container vigorously every 15 min. After 2 h, remove the container, dry the outside with a tissue and allow to cool to room temperature. Remove the lid or cap entirely and thoroughly mix the contents by stirring with a spoon or spatula. (If fat separates, do not test the sample.) Transfer the test sample as completely as possible to a second sample container provided with an airtight lid. Close this container.

### **8.2 Viscous or pasty products**

Open the sample container and thoroughly mix the contents with a spoon or spatula. If possible, use an up-and-down rotary movement in such a way that the top layers and the contents of the lower corners of the container are moved and mixed. Take care to incorporate in the test sample any fat or other constituents adhering to the wall and ends of the container. Transfer the test sample as completely as possible to a second sample container provided with an airtight lid. Close this container.

If necessary, condition the unopened sample container in the water bath (6.5) set at between 30 °C and 40 °C. Remove the container, dry the outside with a tissue and open it. Scrape out all test sample adhering to the interior of the container. Transfer the test sample to a dish large enough to permit thorough stirring, and mix until the whole mass is homogeneous. Transfer the test sample as completely as possible to a second sample container provided with an airtight lid. Close this container.

### **8.3 Dried products**

Thoroughly mix the sample container by repeatedly rotating and inverting. If necessary, transfer all of the test sample to a suitable airtight sample container of sufficient capacity to allow this operation to be carried out.

## **9 Procedure**

NOTE 1 If it is required to check whether the repeatability limit (11.2) is met, carry out two single determinations in accordance with 9.1 to 9.4.

NOTE 2 An alternative procedure using fat-extraction tubes with siphon or wash-bottle fittings (see note in 6.6) is given in annex B.

### **9.1 Test portion**

Mix the test sample (clause 8) in the case of viscous, pasty or dried products by stirring, or in the case of liquid products by gently inverting the sample container three or four times. Immediately weigh to the nearest 1 mg, directly or by difference, 1,5 g to 10 g of the test sample, corresponding to 1,0 to 1,5 g of dry matter, in a fat-extraction flask (6.6).

Transfer the test portion as completely as possible into the lower (small) bulb of the fat-extraction flask.

### **9.2 Blank tests**

#### **9.2.1 Blank test for method**

Carry out a blank test simultaneously with the determination using the same procedure and same reagents, but replacing the dispersed test portion in 9.4.1 by 10 ml of water (see A.2).

If the value obtained in the blank test regularly exceeds 1,0 mg, check the reagents if this has not been recently done (9.2.2). Corrections of more than 2,5 mg should be mentioned in the test report.

### 9.2.2 Blank test for reagents

To test the quality of the reagents, carry out a blank test as specified in 9.2.1. Additionally use an empty fat-collecting vessel, prepared as specified in 9.3, for mass control purposes. The reagents shall leave no residue greater than 1,0 mg (see A.1).

If the residue of the complete reagent blank test is greater than 1,0 mg, determine the residue of the solvents separately by distilling 100 ml of the diethyl ether (5.4) and light petroleum (5.5), respectively. Use an empty fat-collecting vessel, prepared for control purposes as described above, to obtain the real mass of residue which shall not exceed 1,0 mg.

Very occasionally, the solvents may contain volatile matter which is strongly retained in fat. If there are indications of the presence of such substances, carry out blank tests on all the reagents and for each solvent using a fat-collecting vessel with about 1 g of anhydrous butterfat. If necessary, redistil solvents in the presence of 1 g of anhydrous butterfat per 100 ml of solvent. Use the solvents only shortly after the redistillation.

Replace unsatisfactory reagents and solvents, or redistil solvents.

### 9.3 Preparation of fat-collecting vessel

Dry a fat-collecting vessel (6.9) with a few boiling aids (6.10) in the oven (6.4) set at 102 °C for 1 h.

NOTE 1 Boiling aids are desirable to promote gentle boiling during the subsequent removal of solvents, especially when using glass fat-collecting vessels; their use is optional with metal dishes.

Protect the fat-collecting vessel from dust and allow it to cool to the temperature of the weighing room (glass fat-collecting vessel for at least 1 h, metal dish for at least 30 min).

NOTE 2 To avoid insufficient cooling or unduly long cooling times, the fat-collecting vessel should not be placed in a desiccator.

Use tongs (6.13) to place the fat-collecting vessel on the balance. Weigh the fat-collecting vessel to the nearest 1,0 mg.

NOTE 3 Tongs should preferably be used to avoid, in particular, temperature variations.

### 9.4 Determination

9.4.1 Carry out the determination without delay.

If necessary, add preheated water at a temperature of 65 °C ± 5 °C to the test portion in the fat-extraction flask (9.1) to obtain a total volume of 10 ml to 11 ml. Use the water to wash the test portion on to the bottom of the flask. Shake gently with slight warming in a water bath (6.5) set at between 40 °C and 60 °C until the test portion is completely dispersed.

9.4.2 Add 2 ml of ammonia solution (5.1) to the dispersed test portion in the fat-extraction flask (9.4.1), or an equivalent volume of a more concentrated ammonia solution (see note in 5.1). Mix thoroughly with the test portion in the small bulb of the fat-extraction flask.

9.4.3 Heat the fat-extraction flask at 65 °C ± 5 °C in the water bath (6.5) for 15 min to 20 min with occasional shaking (optional in the case of liquid products). Cool in running water to room temperature.

9.4.4 Add 10 ml of ethanol (5.2). Mix gently but thoroughly by allowing the contents of the fat-extraction flask to flow backwards and forwards between the small and large bulb. Avoid bringing the liquid too near to the neck of the flask. If desired, add 2 drops of the Congo red solution (5.3). Cool in running water to room temperature.

**9.4.5** Add 25 ml of diethyl ether (5.4). Close the fat-extraction flask with a cork saturated with water or with a stopper of other material wetted with water (6.6). Shake the flask vigorously, but not excessively, for 1 min to avoid the formation of persistent emulsions.

While shaking, keep the fat-extraction flask in a horizontal position with the small bulb extending upwards, periodically allowing the liquid to run from the large bulb into the small bulb. If necessary, cool the flask in running water to about room temperature. Carefully remove the cork or stopper and rinse it and the neck of the flask with a little mixed solvent (5.6). Use the wash bottle (6.8) so that the rinsings run into the flask.

**9.4.6** Add 25 ml of the light petroleum (5.5). Close the fat-extraction flask with the rewetted (by dipping into water) cork or stopper. Mix gently again for 30 s as described in 9.4.4. Proceed with shaking as described in 9.4.5.

**9.4.7** Centrifuge the closed fat-extraction flask for between 1 min and 5 min at a radial acceleration of 80 *g* to 90 *g*. If a centrifuge (6.2) is not available, allow the closed flask to stand in the rack (6.7) for at least 30 min until the supernatant layer is clear and distinctly separated from the aqueous layer. If necessary, cool the flask in running water to room temperature.

**9.4.8** Carefully remove the cork or stopper and rinse it and the inside of the neck of the fat-extraction flask with a little mixed solvent (5.6). Use the wash bottle (6.8) so that the rinsings run into the flask. If the interface is below the bottom of the stem of the flask, raise it slightly above this level by gently adding water down the side of the flask (see Figure 1) to facilitate the decanting of solvent.

**NOTE** In Figures 1 and 2, one of the three types of fat-extraction flasks as specified in ISO 3889 has been chosen, but this does not imply any preference over other types.

**9.4.9** Hold the fat-extraction flask by the small bulb and carefully decant as much as possible of the supernatant layer into the prepared fat-collecting vessel (see 9.3) containing a few boiling aids (6.10) in the case of a boiling or conical flask (optional with metal dishes). Avoid decanting any of the aqueous layer (see Figure 2).

**9.4.10** Rinse the outside of the neck of the fat-extraction flask with a little mixed solvent (5.6). Collect the rinsings in the fat-collecting vessel. Take care that the mixed solvent does not spread over the outside of the fat-extraction flask. If desired, remove the solvent or a part of it from the fat-collecting vessel by distillation or evaporation as described in 9.4.14.

**9.4.11** Add 5 ml of ethanol (5.2) to the contents of the fat-extraction flask. Using the ethanol, rinse the inside of the neck of the flask and mix as described in 9.4.4.

**9.4.12** Carry out a second extraction by repeating the operations described in 9.4.5 to 9.4.9 inclusive. Instead of 25 ml, use only 15 ml of diethyl ether (5.4) and 15 ml of light petroleum (5.5). Using the diethyl ether, rinse the inside of the neck of the fat-extraction flask too.

If necessary, raise the interface slightly to the middle of the stem of the flask by gently adding water down the side of the flask (see Figure 1) to enable the final decanting of solvent to be as complete as possible (see Figure 2).

**9.4.13** Carry out a third extraction without addition of ethanol by again repeating the operations described in 9.4.5 to 9.4.9 inclusive. Again, use only 15 ml of diethyl ether (5.4) and 15 ml of light petroleum (5.5). Using the diethyl ether, rinse the inside of the neck of the fat-extraction flask again.

If necessary, raise the interface slightly to the middle of the stem of the flask by gently adding water down the side of the flask (see Figure 1) to enable the final decanting of solvent to be as complete as possible (see Figure 2).

**NOTE** The third extraction may be omitted for products with a fat content of less than 5 % (dry matter).

**9.4.14** Remove the solvents (including the ethanol) as completely as possible from the fat-collecting vessel by distillation if using a boiling or conical flask, or by evaporation if using a beaker or dish (6.3). Rinse the inside of the neck of the conical flask with a little mixed solvent (5.6) before commencing the distillation.

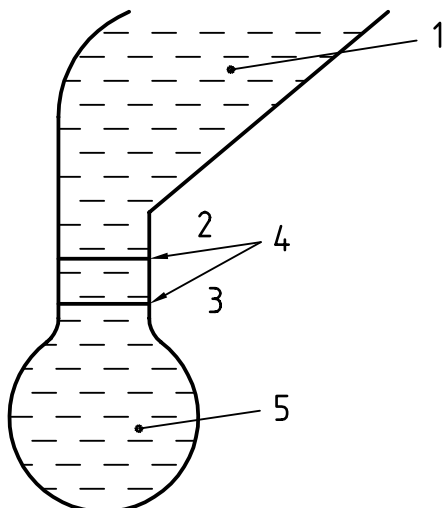
**Key**

- 1 Solvent
- 2 At second and third extraction
- 3 At first extraction
- 4 Interface
- 5 Aqueous layer

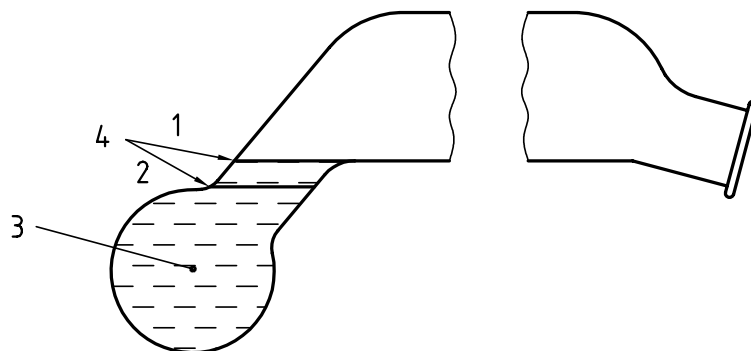
**Figure 1 — Before decanting****Key**

- 1 At second and third extraction
- 2 At first extraction
- 3 Aqueous layer
- 4 Interface

**Figure 2 — After decanting**

**9.4.15** Heat the fat-collecting vessel, with the boiling or conical flask placed on its side to allow solvent vapour to escape, for 1 h in the drying oven (6.4) set at 102 °C. Remove the fat-collecting vessel from the oven and immediately verify whether or not the fat is clear. If the fat is not clear, fatty extraneous matter is presumed to be present and the whole procedure shall be repeated. If the fat is clear, protect the fat-collecting vessel from dust and allow the fat-collecting vessel to cool (preferable not in a desiccator) to the temperature of the weighing room (a glass fat-collecting vessel for at least 1 h, a metal dish for at least 30 min).

Do not wipe the fat-collecting vessel immediately before weighing. Use tongs (6.13) to place the fat-collecting vessel on the balance. Weigh the fat-collecting vessel to the nearest 1,0 mg.

**9.4.16** Heat the fat-collecting vessel, with the boiling or conical flask placed on its side to allow solvent vapour to escape, for a further 30 min in the drying oven (6.4) set at 102 °C. Cool and reweigh as described in 9.4.15. If necessary, repeat the heating and weighing procedures until the mass of the fat-collecting vessel decreases by 1,0 mg or less, or increases between two successive weighings. Record the minimum mass as the mass of the fat-collecting vessel and extracted matter.

## 10 Calculation and expression of results

### 10.1 Calculation

Calculate the fat content of the sample using the following equation:

$$w_f = \frac{(m_1 - m_2) - (m_3 - m_4)}{m_0} \times 100 \%$$

where

- $w_f$  is the mass fraction of fat in the sample, in percent;
- $m_0$  is the mass of the test portion (9.1), in grams;
- $m_1$  is the mass of the fat-collecting vessel and extracted matter, determined in 9.4.16, in grams;
- $m_2$  is the mass of the prepared fat-collecting vessel (9.3), in grams;
- $m_3$  is the mass of the fat-collecting vessel used in the blank test (9.2) and any extracted matter determined in 9.4.16, in grams;
- $m_4$  is the mass of the fat-collecting vessel (9.3) used in the blank test (9.2), in grams.

## 10.2 Expression of results

Round the result to two decimal places.

## 11 Precision

### 11.1 Interlaboratory test

Details of an interlaboratory test in accordance with ISO 5725<sup>1)</sup> on the precision of the method have been published (see reference [6]).

The values for repeatability and reproducibility limits are expressed for the 95 % probability level and may not be applicable to concentration ranges and matrices other than those given.

### 11.2 Repeatability

The absolute difference between two independent single test results, obtained using the same method on identical test material in the same laboratory by the same operator using the same equipment within a short interval of time, will in not more than 5 % of cases be greater than a mass fraction of:

- 0,05 %, for liquid products;
- 0,1 %, for products with a fat content of 5 % or less;
- 0,2 %, for products with a fat content of more than 5 %.

### 11.3 Reproducibility

The absolute difference between two independent single test results, obtained using the same method on identical test material in different laboratories with different operators using different equipment, will in not more than 5 % of cases be greater than a mass fraction of:

- 0,1 %, for liquid products;
- 0,2 %, for products with a fat content of 5 % or less;
- 0,4 %, for products with a fat content of more than 5 %.

---

<sup>1)</sup> ISO 5725:1986 (now withdrawn) was used to obtain the precision data.



## 12 Test report

The test report shall specify:

- all information necessary for the complete identification of the sample;
- the sampling method used, if known;
- the test method used, together with reference to this International Standard;
- all operating details not specified in this International Standard, or regarded as optional, together with details of any incidents which may have influenced the test result(s);
- the corrections made, if a value of more than 2,5 mg is obtained in the blank test for the method;
- the test result(s) obtained; or if the repeatability has been checked, the final quoted result obtained.

## Annex A (informative)

### Notes on procedures

#### A.1 Blank test to check the reagents (see 9.2.2)

In this blank test, a fat-collecting vessel for mass control purposes has to be used in order that changes in the atmospheric condition of the balance room or temperature effects of the fat-collecting vessel will not falsely suggest the presence or absence of non-volatile matter in the extract of the reagents. This fat-collecting vessel may be used as a counterweight vessel in the case of a two-pan balance. Otherwise deviations of the apparent mass ( $m_3 - m_4$  in 10.1) of the fat-collecting vessel for control purposes should be considered when checking the mass of the fat-collecting vessel used for the blank test. Hence, the change in apparent mass of the fat-collecting vessel, corrected for the apparent change in mass of the fat-collecting vessel for control purposes, shall show no increase in mass greater than 1,0 mg.

Very occasionally, the solvents may contain volatile matter which is strongly retained in fat. If there are indications of the presence of such substances, carry out blank tests on all the reagents and for each solvent using a fat-collecting vessel with about 1 g of anhydrous butterfat. If necessary, redistil solvents in the presence of 1 g of anhydrous butterfat per 100 ml of solvent. Use the solvents only shortly after redistillation.

#### A.2 Blank test carried out simultaneously with the determination (see 9.2.1)

The value obtained in the blank test, carried out simultaneously with the determination, enables the apparent mass of substances extracted from a test portion ( $m_1 - m_2$ ) to be corrected for the presence of any non-volatile matter derived from the reagents and also for any change of atmospheric conditions of the balance room and some temperature difference between the fat-collecting vessel and the balance room at the two weighings (9.4.16 and 9.3).

Under favourable conditions (low value in the blank test on reagents, equable temperature of the balance room, sufficient cooling time for fat-collecting vessel), the value will usually be less than 1,0 mg and can then be neglected in the calculation in the case of routine determinations. Slightly higher values (positive and negative) up to 2,5 mg are also often encountered. After correction for these values, the results will still be accurate. When corrections of more than 2,5 mg are applied, it should be mentioned in the test report (clause 12).

If the value obtained in this blank test regularly exceeds 1,0 mg, the reagents should be checked, if no recent check has been made. Any impure reagent or reagents traced should be replaced or purified (see 9.2.2 and A.1).

#### A.3 Test for peroxides

To test for peroxides, add 1 ml of a freshly prepared 100 g/l potassium iodide solution to 10 ml of the diethyl ether in a small glass-stoppered cylinder which has been previously rinsed with the ether. Shake the cylinder and allow to stand for 1 min. No yellow colour should be observed in the diethyl ether layer.

Other suitable methods of testing for peroxides may be used.

To ensure that the diethyl ether is free, and is maintained free, from peroxides, treat the diethyl ether at least 3 days before it is to be used as follows.

Cut zinc foil into strips that will reach at least half-way up the bottle containing the diethyl ether, using approximately 80 cm<sup>2</sup> of foil per litre of diethyl ether.

Before use, completely immerse the strips of foil for 1 min in a solution containing 10 g/l of copper(II) sulfate pentahydrate ( $\text{CuSO}_4 \cdot 5\text{H}_2\text{O}$ ) and 2 ml/l of concentrated [98 % (mass fraction)] sulfuric acid.

Wash the strips gently but thoroughly with water, place the wet copper-plated strips in the bottle containing the diethyl ether, and leave the strips in the bottle.

Other methods may be used provided that they do not affect the result of the determination.

#### **A.4 Diethyl ether containing antioxidants**

Diethyl ether containing about 1 mg of antioxidants per kilogram is available in some countries, especially for fat determinations. This content does not exclude its use for reference purposes.

In other countries, diethyl ether with higher antioxidant contents, for example up to 7 mg/kg, is available. Such ether should only be used for routine determinations with an obligatory blank test carried out simultaneously with the determination(s) to correct for systematic errors due to the antioxidant residue. For reference purposes, such diethyl ether shall always be distilled before use.

#### **A.5 Ethanol**

Ethanol denatured otherwise than by the addition of methanol may be used provided that the denaturant does not affect the result of the determination.

## Annex B (informative)

### Alternative procedure using fat-extraction tubes with siphon or wash-bottle fittings

#### B.1 General

If fat-extraction tubes with siphon or wash-bottle fittings are to be used, use the procedure specified in this annex. The tubes shall be provided with good quality bark corks or stoppers as specified for the flasks in 6.6 (see Figure B.1 as an example).

#### B.2 Procedure

##### B.2.1 Preparation of test sample

See clause 8.

##### B.2.2 Test portion

Proceed as specified in 9.1 but using the fat-extraction tubes (see note in 6.6 and Figure B.1).

The test portion shall be delivered as completely as possible to the bottom of the fat-extraction tube.

##### B.2.3 Blank test

See 9.2 and A.2.

##### B.2.4 Preparation of fat-collecting vessel

See 9.3.

##### B.2.5 Determination

**B.2.5.1** Carry out the determination without delay.

If necessary, add preheated water at a temperature of  $65\text{ °C} \pm 5\text{ °C}$  to the test portion in the fat-extraction tube (9.1) to obtain a total volume of 10 ml to 11 ml. Use the water to wash the test portion on to the bottom of the tube. Shake gently with slight warming in a water bath (6.5) set at between  $40\text{ °C}$  to  $60\text{ °C}$  until the test portion is completely dispersed.

**B.2.5.2** Add 2 ml of ammonia solution (5.1) to the test portion in the fat-extraction tube (B.2.5.1), or an equivalent volume of a more concentrated ammonia solution (see note in 5.1). Mix thoroughly with the pretreated test portion at the bottom of the fat-extraction tube.

**B.2.5.3** Heat the fat-extraction tube at  $65\text{ °C} \pm 5\text{ °C}$  in the water bath (6.5) for 15 min to 20 min with occasional shaking (optional in the case of liquid products). Cool in running water to room temperature.

**B.2.5.4** Add 10 ml of ethanol (5.2). Mix gently but thoroughly with the mixture at the bottom of the fat-extraction tube. If desired, add 2 drops of the Congo red solution (5.3).

Dimensions in millimetres

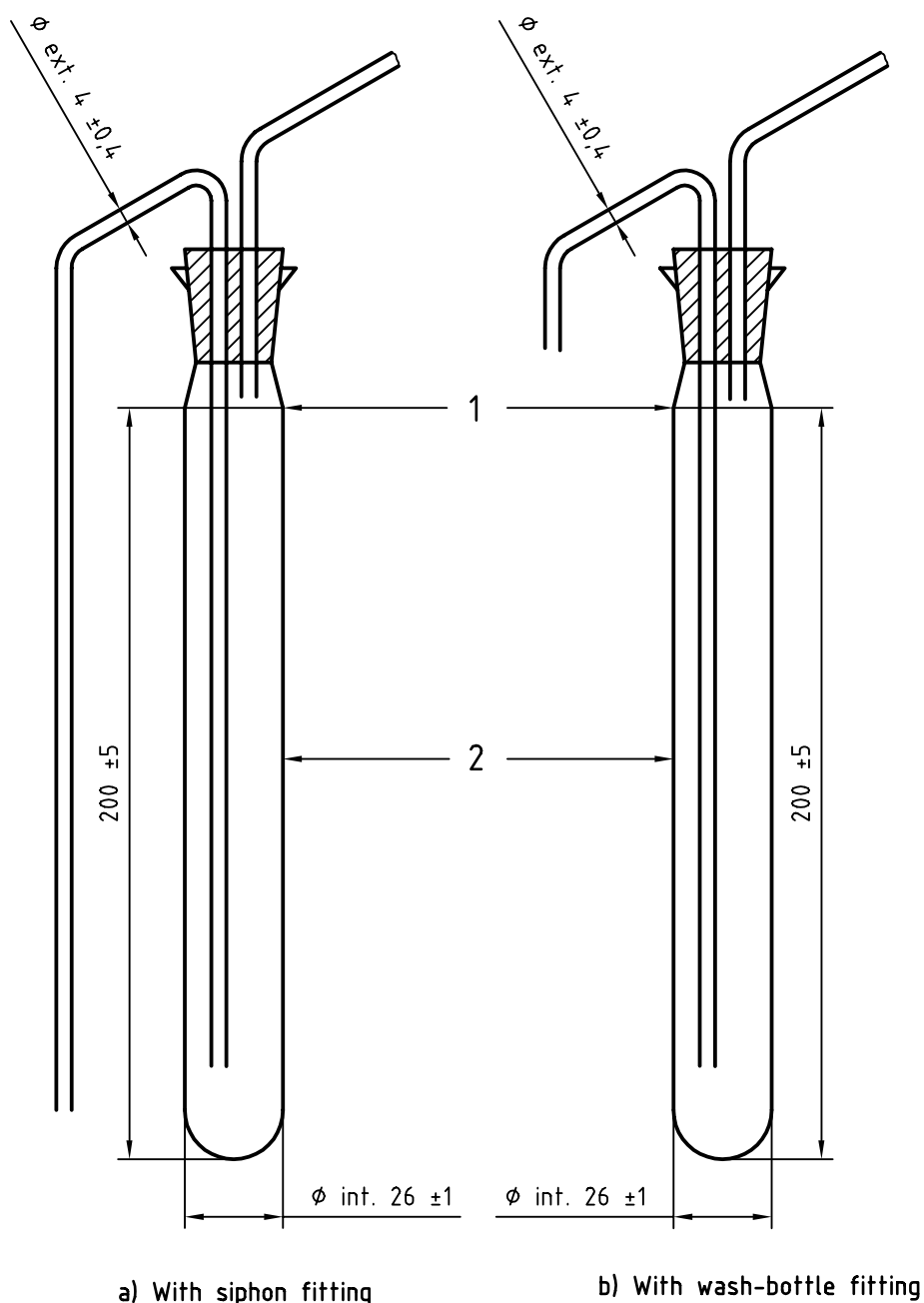
**Key**

- 1 Capacity to this level with fittings removed  $105 \text{ ml} \pm 5 \text{ ml}$
- 2 Wall thickness  $1,5 \text{ mm} \pm 0,5 \text{ mm}$

**Figure B.1 — Examples of fat-extraction tubes**

**B.2.5.5** Add 25 ml of diethyl ether (5.4). Close the fat-extraction tube with a cork saturated with water or with a stopper of other material wetted with water (6.6). Shake the tube vigorously, but not excessively, with repeated inversions for 1 min, to avoid the formation of persistent emulsions. If necessary, cool the tube in running water. Carefully remove the cork or stopper and rinse it and the neck of the tube with a little mixed solvent (5.6). Use the wash bottle (6.8) so that the rinsings run into the tube.

**B.2.5.6** Add 25 ml of the light petroleum (5.5). Close the fat-extraction tube with the rewetted (by dipping in water) cork or stopper. Shake the tube gently for 30 s, as described in B.2.5.5.

**B.2.5.7** Centrifuge the closed fat-extraction tube for 1 min to 5 min at a radial acceleration of 80 *g* to 90 *g*. If a centrifuge (6.2) is not available, allow the closed tube to stand in the rack (6.7) for at least 30 min until the supernatant layer is clear and distinctly separated from the aqueous layer. If necessary, cool the tube in running water to room temperature.

**B.2.5.8** Carefully remove the cork or stopper and rinse it and the neck of the fat-extraction tube with a little mixed solvent (5.6). Use the wash bottle (6.8) so that the rinsings run into the tube.

**B.2.5.9** Insert a siphon fitting or a wash-bottle fitting into the fat-extraction tube. Push down the long inner limb of the fitting until the inlet is approximately 4 mm above the interface between the layers. The inner limb of the fitting shall be parallel to the axis of the fat-extraction tube.

Carefully transfer the supernatant layer out of the fat-extraction tube into the fat-collecting vessel (see 9.3) containing a few boiling aids (6.10) in the case of boiling or conical flasks (optional with metal dishes). Avoid the transfer of any of the aqueous layer. Rinse the outlet of the fitting with a little mixed solvent, collecting the rinsings in the fat-collecting vessel.

**NOTE** The supernatant layer can be transferred out of the fat-extraction tube by using, for example, a rubber bulb attached to the short stem to apply pressure.

**B.2.5.10** Loosen the fitting from the neck of the fat-extraction tube. Slightly raise the fitting and rinse the lower part of its long inner limb with a little mixed solvent (5.6). Lower and re-insert the fitting and transfer the rinsings to the fat-collecting vessel.

Rinse the outlet of the fitting with a little mixed solvent again, collecting the rinsings in the fat-collecting vessel. If desired, remove the solvent or a part of it from the fat-collecting vessel by distillation or evaporation as described in 9.4.14.

**B.2.5.11** Again loosen the fitting from the neck. Slightly raise the fitting and add 5 ml of ethanol to the contents of the fat-extraction tube. Use the ethanol to rinse the long inner limb of the fitting. Mix as described in B.2.5.4.

**B.2.5.12** Carry out a second extraction by repeating the operations described in B.2.5.5 to B.2.5.10. Instead of 25 ml, use only 15 ml of diethyl ether (5.4) and 15 ml of light petroleum (5.5). Use the diethyl ether to rinse the long inner limb of the fitting during the removal of the fitting from the fat-extraction tube after the previous extraction.

**B.2.5.13** Carry out a third extraction without the addition of ethanol by again repeating the operations described in B.2.5.5 to B.2.5.10. Again, use only 15 ml of diethyl ether and 15 ml of light petroleum. Using the diethyl ether, rinse the long inner limb of the fitting as described in B.2.5.12.

**B.2.5.14** Proceed as described in 9.4.14 to 9.4.16.

## Bibliography

- [1] ISO 707, *Milk and milk products — Guidance on sampling.*
- [2] ISO 5725:1986, *Precision of test methods — Determination of repeatability and reproducibility for standard tests methods by inter-laboratory tests.*
- [3] ISO 5725-1:1994, *Accuracy (trueness and precision) of measurement methods and results — Part 1: General principles and definitions.*
- [4] ISO 5725-2:1994, *Accuracy (trueness and precision) of measurement methods and results — Part 2: Basic method for the determination of repeatability and reproducibility of a standard measurement method.*
- [5] ISO 8262-1, *Milk products and milk-based foods — Determination of fat content by the Weibull-Berntrop gravimetric method (reference method) — Part 1: Infant foods.*
- [6] International Dairy Federation. Interlaboratory Collaborative Studies, Second series, *Bull. Int. Dairy Fed.*, No. 235, 1988.

---

---

## **BSI — British Standards Institution**

BSI is the independent national body responsible for preparing British Standards. It presents the UK view on standards in Europe and at the international level. It is incorporated by Royal Charter.

### **Revisions**

British Standards are updated by amendment or revision. Users of British Standards should make sure that they possess the latest amendments or editions.

It is the constant aim of BSI to improve the quality of our products and services. We would be grateful if anyone finding an inaccuracy or ambiguity while using this British Standard would inform the Secretary of the technical committee responsible, the identity of which can be found on the inside front cover. Tel: 020 8996 9000. Fax: 020 8996 7400.

BSI offers members an individual updating service called PLUS which ensures that subscribers automatically receive the latest editions of standards.

### **Buying standards**

Orders for all BSI, international and foreign standards publications should be addressed to Customer Services. Tel: 020 8996 9001. Fax: 020 8996 7001.

In response to orders for international standards, it is BSI policy to supply the BSI implementation of those that have been published as British Standards, unless otherwise requested.

### **Information on standards**

BSI provides a wide range of information on national, European and international standards through its Library and its Technical Help to Exporters Service. Various BSI electronic information services are also available which give details on all its products and services. Contact the Information Centre. Tel: 020 8996 7111. Fax: 020 8996 7048.

Subscribing members of BSI are kept up to date with standards developments and receive substantial discounts on the purchase price of standards. For details of these and other benefits contact Membership Administration. Tel: 020 8996 7002. Fax: 020 8996 7001.

### **Copyright**

Copyright subsists in all BSI publications. BSI also holds the copyright, in the UK, of the publications of the international standardization bodies. Except as permitted under the Copyright, Designs and Patents Act 1988 no extract may be reproduced, stored in a retrieval system or transmitted in any form or by any means – electronic, photocopying, recording or otherwise – without prior written permission from BSI.

This does not preclude the free use, in the course of implementing the standard, of necessary details such as symbols, and size, type or grade designations. If these details are to be used for any other purpose than implementation then the prior written permission of BSI must be obtained.

If permission is granted, the terms may include royalty payments or a licensing agreement. Details and advice can be obtained from the Copyright Manager. Tel: 020 8996 7070.