

BS EN ISO 7783:2011



BSI Standards Publication

**Paints and varnishes —
Determination of water-vapour
transmission properties — Cup
method (ISO 7783:2011)**

bsi.

...making excellence a habit.™

National foreword

This British Standard is the UK implementation of EN ISO 7783:2011. It supersedes BS EN ISO 7783-1:2000 and BS EN ISO 7783-2:1999 which are withdrawn

The UK participation in its preparation was entrusted to Technical Committee STI/10, Test methods for paints.

A list of organizations represented on this committee can be obtained on request to its secretary.

This publication does not purport to include all the necessary provisions of a contract. Users are responsible for its correct application.

© BSI 2011

ISBN 978 0 580 64430 6

ICS 87.040

Compliance with a British Standard cannot confer immunity from legal obligations.

This British Standard was published under the authority of the Standards Policy and Strategy Committee on 30 November 2011.

Amendments issued since publication

Date	Text affected
------	---------------

EUROPEAN STANDARD

EN ISO 7783

NORME EUROPÉENNE

EUROPÄISCHE NORM

November 2011

ICS 87.040

Supersedes EN ISO 7783-1:1999, EN ISO 7783-2:1999

English Version

Paints and varnishes - Determination of water-vapour transmission properties - Cup method (ISO 7783:2011)

Peintures et vernis - Détermination des propriétés de
transmission de la vapeur d'eau - Méthode de la coupelle
(ISO 7783:2011)

Beschichtungsstoffe - Bestimmung der
Wasserdampfdurchlässigkeit - Schalenverfahren (ISO
7783:2011)

This European Standard was approved by CEN on 21 November 2011.

CEN members are bound to comply with the CEN/CENELEC Internal Regulations which stipulate the conditions for giving this European Standard the status of a national standard without any alteration. Up-to-date lists and bibliographical references concerning such national standards may be obtained on application to the CEN-CENELEC Management Centre or to any CEN member.

This European Standard exists in three official versions (English, French, German). A version in any other language made by translation under the responsibility of a CEN member into its own language and notified to the CEN-CENELEC Management Centre has the same status as the official versions.

CEN members are the national standards bodies of Austria, Belgium, Bulgaria, Croatia, Cyprus, Czech Republic, Denmark, Estonia, Finland, France, Germany, Greece, Hungary, Iceland, Ireland, Italy, Latvia, Lithuania, Luxembourg, Malta, Netherlands, Norway, Poland, Portugal, Romania, Slovakia, Slovenia, Spain, Sweden, Switzerland and United Kingdom.



EUROPEAN COMMITTEE FOR STANDARDIZATION
COMITÉ EUROPÉEN DE NORMALISATION
EUROPÄISCHES KOMITEE FÜR NORMUNG

Management Centre: Avenue Marnix 17, B-1000 Brussels

Foreword

This document (EN ISO 7783:2011) has been prepared by Technical Committee ISO/TC 35 "Paints and varnishes" in collaboration with Technical Committee CEN/TC 139 "Paints and varnishes" the secretariat of which is held by DIN.

This European Standard shall be given the status of a national standard, either by publication of an identical text or by endorsement, at the latest by May 2012, and conflicting national standards shall be withdrawn at the latest by May 2012.

Attention is drawn to the possibility that some of the elements of this document may be the subject of patent rights. CEN [and/or CENELEC] shall not be held responsible for identifying any or all such patent rights.

This document supersedes EN ISO 7783-1:1999, EN ISO 7783-2:1999.

According to the CEN/CENELEC Internal Regulations, the national standards organizations of the following countries are bound to implement this European Standard: Austria, Belgium, Bulgaria, Croatia, Cyprus, Czech Republic, Denmark, Estonia, Finland, France, Germany, Greece, Hungary, Iceland, Ireland, Italy, Latvia, Lithuania, Luxembourg, Malta, Netherlands, Norway, Poland, Portugal, Romania, Slovakia, Slovenia, Spain, Sweden, Switzerland and the United Kingdom.

Endorsement notice

The text of ISO 7783:2011 has been approved by CEN as a EN ISO 7783:2011 without any modification.

Contents

Page

Foreword	iv
Introduction	v
1 Scope	1
2 Normative references	1
3 Terms and definitions	1
4 Principle	3
5 Apparatus and materials	3
5.1 Substrate for non-self-supporting coatings	3
5.2 Test cup	3
5.3 Ammonium dihydrogen phosphate (NH ₄ H ₂ PO ₄) solution for wet-cup method	3
5.4 Desiccant for dry-cup method	3
5.5 Sealing material	4
5.6 Test enclosure	4
5.7 Balance	4
6 Preparation for the test	4
6.1 Sampling of coating material	4
6.2 Preparation of test pieces	4
6.3 Determination of the thickness of the coating	5
6.4 Preparation of the test assemblies	6
7 Procedure	6
8 Expression of results	7
8.1 Water-vapour transmission rate, V , of self-supporting coatings	7
8.2 Water-vapour transmission rate, V , of non-self-supporting coatings	7
8.3 Water-vapour diffusion-equivalent air layer thickness, s_d	9
8.4 Water-vapour resistance factor, μ	9
9 Precision	10
9.1 Repeatability, (r)	10
9.2 Reproducibility, (R)	10
10 Test report	10
Annex A (informative) Derivation of Equation (8) in Subclause 8.3 for the calculation of the water- vapour diffusion-equivalent air layer thickness, s_d	12
Annex B (normative) Use of molten wax for sealing the test assembly	14
Bibliography	18

Foreword

ISO (the International Organization for Standardization) is a worldwide federation of national standards bodies (ISO member bodies). The work of preparing International Standards is normally carried out through ISO technical committees. Each member body interested in a subject for which a technical committee has been established has the right to be represented on that committee. International organizations, governmental and non-governmental, in liaison with ISO, also take part in the work. ISO collaborates closely with the International Electrotechnical Commission (IEC) on all matters of electrotechnical standardization.

International Standards are drafted in accordance with the rules given in the ISO/IEC Directives, Part 2.

The main task of technical committees is to prepare International Standards. Draft International Standards adopted by the technical committees are circulated to the member bodies for voting. Publication as an International Standard requires approval by at least 75 % of the member bodies casting a vote.

Attention is drawn to the possibility that some of the elements of this document may be the subject of patent rights. ISO shall not be held responsible for identifying any or all such patent rights.

ISO 7783 was prepared by Technical Committee ISO/TC 35, *Paints and varnishes*, Subcommittee SC 9, *General test methods for paints and varnishes*.

This first edition of ISO 7783 cancels and replaces ISO 7783-1:1996 and ISO 7783-2:1999, which have been merged and technically revised. It also incorporates the Technical Corrigendum ISO 7783-1:1996/Cor.1:1998.

Introduction

ISO 7783 is one of a series of standards dealing with the sampling and testing of paints, varnishes and related products. It describes a method for determining the water-vapour transmission rate of self-supporting and non-self-supporting coatings.

The water-vapour transmission rate is not necessarily a linear function of film thickness, temperature or relative-humidity difference. A determination carried out under one set of conditions will not necessarily be comparable with one carried out under other conditions. Therefore, it is essential that the conditions of test are chosen to be as close as possible to the conditions of use.

Water-vapour transmission is of greatest interest under conditions of high humidity. For this reason, the wet-cup method has been adopted as the reference method. By agreement, other procedures and conditions, like the dry-cup method, may be used.

Paints and varnishes — Determination of water-vapour transmission properties — Cup method

1 Scope

This International Standard specifies a method for determining the water-vapour transmission properties of coatings of paints, varnishes and related products.

It supplements ISO 12572. As far as possible, the procedure, the definitions and the calculations have been taken over from ISO 12572. It is recommended that ISO 12572 be consulted, if necessary, to obtain a better understanding of the procedure specified in this International Standard.

Water-vapour transmission rates of more than $680 \text{ g}/(\text{m}^2\text{-d})$ (i.e. water-vapour diffusion-equivalent air layer thicknesses, s_d , of less than 0,03 m) will not be accurately quantified by the test method described in this International Standard.

2 Normative references

The following referenced documents are indispensable for the application of this document. For dated references, only the edition cited applies. For undated references, the latest edition of the referenced document (including any amendments) applies.

ISO 1513, *Paints and varnishes — Examination and preparation of test samples*

ISO 2808, *Paints and varnishes — Determination of film thickness*

ISO 3233, *Paints and varnishes — Determination of percentage volume of non-volatile matter by measuring the density of a dried coating*

ISO 3696, *Water for analytical laboratory use — Specification and test methods*

ISO 15528, *Paints, varnishes and raw materials for paints and varnishes — Sampling*

3 Terms and definitions

For the purposes of this document, the following terms and definitions apply.

3.1

water-vapour transmission rate

V

mass of water vapour that is transmitted over a given period through a given surface area of a test piece under specified constant conditions of relative humidity at each face of the test piece

NOTE 1 It is measured in grams per square metre per day [$\text{g}/(\text{m}^2\text{-d})$].

NOTE 2 A water-vapour transmission rate measured at atmospheric pressure, p , can be converted to the equivalent value at standard atmospheric pressure, p_0 , by multiplying by p/p_0 . This allows a linear correlation with the water-vapour diffusion-equivalent air layer thickness (s_d) value (see 3.3) by the factor 20,4.

NOTE 3 The term “water-vapour transmission” is often incorrectly used for water-vapour transmission rate.

3.2
rate of flow of water vapour through the test piece

G

mass of water vapour that is transmitted over a given period through a test piece under specified constant conditions of relative humidity at each face of the test piece

NOTE It is measured in grams per hour.

3.3
water-vapour diffusion-equivalent air layer thickness

s_d

thickness of a static air layer that has, under the same conditions of measurement, the same water-vapour transmission rate as the coating tested

NOTE It is measured in metres.

3.4
water-vapour resistance factor

μ

factor that indicates how many times greater the water-vapour resistance of a material is compared with a layer of static air of the same thickness at the same temperature and pressure

NOTE 1 It is dimensionless.

NOTE 2 The calculation and use of a water-vapour resistance factor is meaningful only if the water-vapour transmission rate of a particular material is a constant, i.e. independent of the thickness, which, however, is normally not the case for coatings.

3.5
test piece

(non-self-supporting coatings) supporting substrate with the coating applied to it or (self-supporting coatings) the coating alone

3.6
wet-cup method

method of measuring water-vapour permeability in which the test piece is sealed to the rim of a cup containing a saturated aqueous solution of ammonium dihydrogen phosphate

NOTE This is the most convenient manner of carrying out determinations of water-vapour permeability under conditions of high relative humidity (between 93 % and 50 %).

3.7
dry-cup method

method of measuring water-vapour permeability in which the test piece is sealed to the rim of a cup containing a desiccant

NOTE This is the most convenient manner of carrying out determinations of water-vapour permeability under conditions of low relative humidity (between 50 % and 3 %).

3.8
test assembly

assembly consisting of a test piece sealed to the rim of a test cup containing saturated ammonium dihydrogen phosphate solution in contact with undissolved ammonium dihydrogen phosphate crystals (wet-cup method) or containing desiccant (dry-cup method)

3.9
test area

area of the face of the test piece through which the water vapour flows during the test

NOTE It is measured in square metres.

4 Principle

A test assembly consisting of a self-supporting coating, or a non-self-supporting coating on porous substrate, sealed to the rim of a cup is placed in a test enclosure kept at a specified temperature (e.g. 23 °C) and relative humidity (e.g. 50 %). The relative humidity in the cup is maintained at a constant level — either at 93 % by means of a saturated salt solution (wet-cup method) or at 3 % by means of a desiccant (dry-cup method). Because of the difference between the partial pressure of the water vapour inside the test cup and the partial pressure of the water vapour in the test enclosure, water vapour diffuses through the coating under test. By weighing the test assembly at suitable time intervals, the change in mass of the test assembly is followed. From the change in mass and the test area, the water-vapour transmission rate and the water-vapour diffusion-equivalent air layer thickness are calculated.

5 Apparatus and materials

5.1 Substrate for non-self-supporting coatings

Any homogenous, porous material which has a water-vapour transmission rate above 240 g/(m²·d) is suitable for use as the substrate for non-self-supporting coatings, for instance polyethylene frits, cellular-concrete discs, glass frits, unglazed ceramic tiles.

When using cellular-concrete substrates, the coating shall be applied on the smooth side.

If the coating system under test does not include a primer and it is necessary to use one before applying the coating system under test, do so, but the transmission rate of the primed substrate will have to be determined separately.

5.2 Test cup

Test cups are made of glass, plastic or metal. The test cup used shall be resistant to corrosion under the conditions of the test.

NOTE For aluminium test cups, a wall thickness of 1 mm has been found to be satisfactory.

The exact surface area of the test piece exposed is defined by the design of the cup. The area of the exposed surface shall be at least 50 cm² for non-self-supporting coatings and at least 10 cm² for self-supporting coatings.

The cup shall be so designed that an efficient seal is made between it and the test piece, using sealing material (see 5.5), if necessary.

When the saturated solution (5.3) or desiccant (5.4) has been placed in the cup, the area of the surface of the saturated solution or desiccant shall be similar to that of the exposed surface of the test piece. The air gap between the test piece and the surface of the solution or desiccant shall be between 10 mm and 30 mm.

5.3 Ammonium dihydrogen phosphate (NH₄H₂PO₄) solution for wet-cup method

Prepare a saturated solution of ammonium dihydrogen phosphate (analytical grade) in contact with undissolved crystals, using water of at least grade 3 purity as defined in ISO 3696.

In the wet-cup method, which is the reference method, the relative humidity in a cup containing this saturated solution will be 93 %. The resulting water vapour pressure difference relative to the test enclosure, in which the relative humidity is maintained at 50 %, is 1 207 Pa at standard temperature (23 °C) and pressure (101 325 Pa).

5.4 Desiccant for dry-cup method

The desiccant shall be either dried silica gel in the form of granules passing a 4 mm sieve but retained on a 1,6 mm sieve, or anhydrous calcium chloride which has been dried at 200 °C.

It shall be possible to complete the test before the efficiency of the desiccant is reduced appreciably.

In the dry-cup method, the relative humidity in the cup shall be 3 %. The resulting water-vapour pressure difference relative to the test enclosure, in which the relative humidity is maintained at 50 %, is 1 400 Pa at standard temperature (23 °C) and pressure (101 325 Pa).

5.5 Sealing material

It shall be ensured that the test assembly is fully sealed, with the exception of the test area. The sealing material shall be impermeable and free from cracks. For sealing, mechanical clamps, wax or two-component sealing materials have been found suitable. The use of molten wax for sealing the test assembly is described in Annex B.

The sealing material shall not contain solvents or other volatile constituents which could cause any change in the coating or lead to weighing errors caused by the evaporation of solvent.

NOTE The most usual way of sealing the cup is to fit the cup with a mechanical clamp or screw device which can incorporate a sealing ring made of a suitable polymeric material. Mechanical sealing might not be suitable if the test piece has a rough surface or if it is very fragile. In such cases, the use of molten wax is more satisfactory.

5.6 Test enclosure

The test enclosure shall be of a design such that both the temperature and the relative humidity in the enclosure can be controlled at the levels required for the test. Thus, for the reference method, the enclosure shall be capable of maintaining the temperature at (23 ± 2) °C and the relative humidity at (50 ± 5) % (standard conditions as defined in ISO 3270). To ensure uniform conditions during the test, the air shall be caused to flow over the outer surface of the test piece at a speed between 0,02 m/s and 0,3 m/s. The ambient air pressure shall be corrected to standard pressure (1 013,25 hPa) as described in 8.1.

NOTE Maintaining the air speed at the correct level is the second most important source of error after preparation of the test pieces.

When cups have to be removed from the test enclosure for weighing, the specified conditions shall be re-established not more than 15 min after the door of the enclosure has been closed. The door shall remain open for the shortest possible time. This is especially important with materials having a high permeability.

5.7 Balance

The balance used shall be suitable for determining the change in mass of the test assembly with an accuracy of 1 mg or better for cups giving a test area of 50 cm² or less, or 10 mg for cups giving a test area greater than 50 cm².

The most suitable arrangement is to have the balance located in the test enclosure. If this is not possible, care shall be taken that no loss in mass occurs during the transport of the test assembly to the balance.

6 Preparation for the test

6.1 Sampling of coating material

Take a representative sample of the product to be tested (or of each product in the case of a multi-coat system), as described in ISO 15528.

Examine and prepare each sample for testing, as described in ISO 1513.

6.2 Preparation of test pieces

6.2.1 Preparation of non-self-supporting coatings on a porous substrate

The substrate shall be clean and dry.

Apply the coating material to be tested to the substrate in accordance with the manufacturer's application instructions. Do not apply less than the amount indicated by the manufacturer and not more than 50 % more, e.g. by applying a larger number of coats or by applying the first coat as a primer coat after dilution. It is essential that the coating be complete, continuous, homogeneous and free from visible imperfections. If the amount necessary to produce such a coating is more than 50 % greater than the amount indicated by the manufacturer, use another substrate or another test method.

Dry the test pieces for 7 days in freely circulating air at (23 ± 2) °C and (50 ± 5) % relative humidity.

6.2.2 Preparation of self-supporting coatings

Use a substrate from which the coating can be easily detached when dry/hard. The most suitable substrates are glass plates coated with high-density polyethylene or polytetrafluoroethylene which is free from surface defects. Other techniques may be used, for example precoating a substrate with a soluble material such as poly(vinyl alcohol) which will permit the coating to be removed easily by soaking in water. This method should be used with caution, however, since water-soluble material can affect the water-vapour permeability of the coating.

Coat the substrate by the method specified by the manufacturer and dry it for 7 days in freely circulating air at (23 ± 2) °C and (50 ± 5) % relative humidity (if stoving is required, care shall be taken to ensure that the substrate chosen is not affected at the relevant temperature).

Remove the coating carefully from the substrate.

Use a cutting template (see Figure B.1) to cut out specimens of a size suitable for the cup. Examine the test pieces visually and discard any which appear to have pinholes.

6.2.3 Conditioning

Method A

For coatings which, in use, will not be exposed to rain, e.g. coatings for interior use or for arid places, condition the test pieces at (23 ± 2) °C and (50 ± 5) % relative humidity for 28 days or until the difference in mass between two consecutive weighings, carried out at 24 h intervals, is less than 1 %.

Method B

Since, in use, the volatile and/or water-soluble constituents of a coating can be removed by the influence of the weather (in particular, water-soluble constituents can be leached out by rainwater), coatings which are affected by rain shall be conditioned prior to the determination of the water-vapour transmission rate by subjecting the test pieces to 3 cycles under the following conditions:

- 24 h in water (tap water) at (23 ± 2) °C;
- 24 h drying at (50 ± 2) °C.

During the weekend or any interruption of the conditioning for other reasons, store the test pieces at (23 ± 2) °C and (50 ± 5) % relative humidity.

After the last cycle, continue to dry the test pieces at (50 ± 2) °C for at least another 24 h. Then condition the test pieces at (23 ± 2) °C and (50 ± 5) % relative humidity for at least 24 h before carrying out the test.

6.3 Determination of the thickness of the coating

6.3.1 General

The thickness, d , of the coating is required for the calculation of the water-vapour resistance factor, μ . It may be determined by calculation or by optical, mechanical or other suitable methods.

NOTE Optical determination of the thickness of the coating can also be used to check the test piece for pores, holes, etc., and to determine the depth of penetration of the coating material into the substrate.

6.3.2 Determination of the thickness of the coating by calculation

Calculate the dry-film thickness, d , in micrometres, from the application rate (the amount of coating material applied), using the following equation:

$$d = \frac{C \times NV_V}{100} \quad (1)$$

where

C is the application rate, in millilitres per square metre;

NV_V is the non-volatile-matter content, expressed as a percentage by volume, determined in accordance with ISO 3233.

6.3.3 Determination of the thickness of the coating by optical, mechanical or other suitable methods

Determine the mean thickness of the coating by a suitable method selected from those specified in ISO 2808.

6.4 Preparation of the test assemblies

Clean and dry the cups, together with any ancillary fittings.

Into each cup introduce a quantity of saturated ammonium dihydrogen phosphate solution (5.3) and additional ammonium dihydrogen phosphate crystals (for the wet-cup method) or desiccant (5.4) (for the dry-cup method) such that there will be an air gap of at least 10 mm below the test piece. An air gap larger than 10 mm, but not larger than 30 mm, is better if ammonium dihydrogen phosphate solution is used, to make handling of the test assembly during weighing easier.

Seal each test piece to a cup with a vapour-tight seal.

If a non-self-supporting coating is being tested, the coated side of the test piece shall face the atmosphere in the test enclosure (50 % relative humidity). It is important that the air gap remain the same throughout the test (see 8.2.1).

NOTE If the test assemblies are removed from the enclosure for weighing, it might be helpful to cover each assembly with a lid marked to indicate the identification of the test assembly.

7 Procedure

Carry out the determination using at least three test pieces.

Weigh the test assemblies on the balance (5.7) and place them in the test enclosure maintained at the conditions of the test. Ensure, in particular, that the speed of the air flow over the outer surface of the test pieces is between 0,02 m/s and 0,3 m/s as this has a significant influence on the rate of flow of water vapour through the test piece (see 5.6).

Determine the loss in mass at appropriate time intervals. The interval between successive weighings should preferably be 24 h, 48 h or 96 h, but shorter time intervals (for example 3 h, 4 h or 8 h) might be necessary for coatings with a high transmission rate. Use a time interval which will give a change in mass between two successive weighings which is at least 5 mg if a balance with an accuracy of 1 mg is used or at least 50 mg if a balance with an accuracy of 10 mg is used. If the first two weighings show a change in mass which is too large or too small, adjust the time interval for subsequent weighings.

Carry out the weighings in a way which will avoid, to the greatest possible extent, any interference in the transmission of the water vapour by the test piece.

Continue the weighings until the change in mass per unit time becomes constant.

It is essential that wetting of the test pieces by the ammonium dihydrogen phosphate solution is avoided. If wetting takes place, repeat the test.

8 Expression of results

8.1 Water-vapour transmission rate, V , of self-supporting coatings

8.1.1 Rate of flow of water vapour, G , through the test piece

For each test assembly, plot the change in mass, in grams, against time, in hours. The test is considered to be complete when three or more points lie in a straight line.

In the linear part of the plot, determine the best-fit straight line through at least three measurement points. The slope of this straight line is the rate of flow of water vapour, G , in grams per hour, through the test piece.

8.1.2 Water-vapour transmission rate, V , of the coating

The water-vapour transmission rate, V , in grams per square metre per day, of the coating, at standard atmospheric pressure, p_0 (i.e. the pressure at mean sea level), is given by Equation (2):

$$V = 24 \times \frac{p}{p_0} \times \frac{G}{A} \quad (2)$$

where

G is the rate of flow of water vapour, in grams per hour, through the test piece;

A is the area, in square metres, of the test piece through which the water vapour flows;

the factor $\frac{p}{p_0}$ corrects the water-vapour transmission rate, V , to standard atmospheric pressure;

the factor 24 converts G from grams per hour to grams per day.

The atmospheric pressure, p , in pascals, at the place of measurement during the test can be calculated with sufficient accuracy from the equation:

$$p = p_0 - \frac{h}{8,5} \quad (3)$$

where

h is the height above sea level, in metres, of the test laboratory;

p_0 is the standard atmospheric pressure, in pascals ($p_0 = 101\,325$ Pa).

NOTE In the calculation of the water-vapour transmission rate, V , in Equation (2), the air gap below the coating is not taken into account because its influence on the water-vapour transmission rate of self-supporting coatings is negligible.

Take as the result the mean value of at least three individual determinations, but include in the calculation of the mean every individual value of V above 680 g/(m²·d). If all the individual values of V are above 680 g/(m²·d), the mean value shall be reported as " $V > 680$ g/(m²·d)" (see Clause 1).

8.2 Water-vapour transmission rate, V , of non-self-supporting coatings

8.2.1 General

When calculating the water-vapour transmission rate of a non-self-supporting coating, the water-vapour transmission rate of the substrate has to be taken into account. The air gap between the ammonium dihydrogen phosphate solution or the desiccant and the test piece will not need to be taken into account since the water-

vapour transmission rate of the coating is obtained by subtracting that for the substrate plus coating from that for the substrate alone, so the influence of the air gap therefore disappears provided the air gap remains the same throughout the test.

8.2.2 Rate of flow of water vapour through the substrate, G_s , and through the substrate plus coating, G_{cs}

For each test assembly, plot the change in mass, in grams, against time, in hours. The test is considered to be complete when three or more points lie in a straight line.

In the linear part of the plot, determine the best-fit straight line through at least three measurement points. The slope of this straight line is the rate of flow of water vapour, in grams per hour, through the substrate plus coating, G_{cs} .

If separate measurements were made on the substrate alone, calculate, in the same way, the rate of flow of water vapour, in grams per hour, through the substrate, G_s .

If the substrate used is sufficiently similar to substrates previously used under the same conditions, a representative mean value may be used as the value of G_s . If this is not the case, the value of G_s will have to be measured prior to the determination.

8.2.3 Water-vapour transmission rate, V_s , of the substrate

The water-vapour transmission rate, V_s , in grams per square metre per day, of the substrate is given by Equation (4):

$$V_s = 24 \times \frac{p}{p_0} \times \frac{G_s}{A_s} \quad (4)$$

where

G_s is the rate of flow of water vapour, in grams per hour, through the substrate;

A_s is the area, in square metres, of the test piece through which the water vapour flows;

the factor $\frac{p}{p_0}$ corrects the water-vapour transmission rate, V_s , to standard atmospheric pressure;

the factor 24 converts G_s from grams per hour to grams per day.

8.2.4 Water-vapour transmission rate, V_{cs} , of the substrate plus coating

The water-vapour transmission rate, V_{cs} , in grams per square metre per day, of the substrate plus coating is given by Equation (5):

$$V_{cs} = 24 \times \frac{p}{p_0} \times \frac{G_{cs}}{A_{cs}} \quad (5)$$

where

G_{cs} is the rate of flow of water vapour, in grams per hour, through the substrate plus coating;

A_{cs} is the area, in square metres, of the substrate plus coating through which the water vapour flows;

the factor $\frac{p}{p_0}$ corrects the water-vapour transmission rate, V_{cs} , to standard atmospheric pressure;

the factor 24 converts G_{cs} from grams per hour to grams per day.

8.2.5 Water-vapour transmission rate, V , of the coating

The water-vapour transmission rate, V , of the coating is calculated, in grams per square metre per day, from the difference between the water-vapour transmission rate of the substrate, V_s , and that of the substrate plus coating, V_{cs} , as shown in Equation (7), which is derived from Equation (6):

$$\frac{1}{V} = \frac{1}{V_{cs}} - \frac{1}{V_s} \quad (6)$$

$$V = \frac{V_{cs} \times V_s}{V_s - V_{cs}} \quad (7)$$

Take as the result the mean value of at least three individual determinations, but include in the calculation every individual value of V above 680 g/(m²·d). If all the individual values of V are above 680 g/(m²·d), the mean value shall be reported as " $V > 680$ g/(m²·d)" (see Clause 1).

8.3 Water-vapour diffusion-equivalent air layer thickness, s_d

If required, the water-vapour diffusion-equivalent air layer thickness, s_d , in metres, is also calculated. This is given by Equation (8) (for the derivation of this equation, see Annex A):

$$s_d = \frac{\delta_a \times \Delta p_V}{V} \quad (8)$$

where

δ_a is the water-vapour permeation coefficient of air at standard temperature and pressure, in grams per metre per day per pascal [at 23 °C (= 296 K) and standard pressure (= 101 325 Pa), the value of δ_a is 0,016 9 g/(m·d·Pa)];

Δp_V is the difference between the partial water-vapour pressure in the test cup and that in the test enclosure (i.e. between the two sides of the coating), in pascals.

For the wet-cup method, for which $\Delta p_V = 1\,207$ Pa, the diffusion-equivalent air layer thickness is calculated using Equation (9):

$$s_d = \frac{20,4}{V} \quad (9)$$

For the dry-cup method, for which $\Delta p_V = 1\,400$ Pa, the diffusion-equivalent air layer thickness is calculated using Equation (10):

$$s_d = \frac{23,7}{V} \quad (10)$$

8.4 Water-vapour resistance factor, μ

If required, the water-vapour resistance factor, μ , may be calculated using Equation (11):

$$\mu = \frac{s_d}{d} \times 10^6 \quad (11)$$

where d is the dry-film thickness, in micrometres (see 6.3).

In the case of textured products like rendering, the particle size of the material may be taken instead of the measured or calculated film thickness.

When calculating values of s_d for different dry-film thicknesses of a particular material, using the equation $s_d = \mu \times d \times 10^{-6}$, μ shall not be treated as a constant for that material. As can be seen from Equation (8), μ depends on Δp_V and therefore changes with ambient temperature and relative humidity.

9 Precision

9.1 Repeatability, (r)

The repeatability is the value below which the absolute difference between two test results (each the mean of three valid determinations) may be expected to lie when using the standardized test method under repeatability conditions, i.e. when the test results are obtained on identical material by one operator in one laboratory within a short interval of time using the standardized test method.

For the method specified in this International Standard, (r) is 40 % (relative to the mean of two test results), with a 95 % probability.

9.2 Reproducibility, (R)

The reproducibility is the value below which the absolute difference between two test results (each the mean of three valid determinations) may be expected to lie when using the standardized test method under repeatability conditions, i.e. when the test results are obtained on identical material by different operators in different laboratories using the standardized test method.

For the method specified in this International Standard, (R) is 100 % (relative to the mean of two test results), with a 95 % probability.

10 Test report

The test report shall contain at least the following information:

- a) all information necessary for identification of the product tested;
- b) a reference to this International Standard, together with its year of issue (i.e. ISO 7783:2011);
- c) the number of test pieces tested;
- d) the method of application of the coating, the application rate (amount of coating material applied), the number of coats and details of any dilution carried out;
- e) the dry-film thickness, in micrometres, of the coating or coating system tested;
- f) (for non-self-supporting coatings) the type of substrate (including the primer, if used) and its average thickness, in millimetres;
- g) whether the dry-cup or the wet-cup method was used;
- h) details of the test assembly used, including the method of preparation and sealing used and the size of the waxing template (B.2.2), if used;
- i) the duration and conditions of drying (or stoving), ageing (if applicable) and conditioning (method A or method B — see 6.2.3) of the test pieces before testing;
- j) the temperature and relative humidity in the test enclosure;
- k) the results of the test, including the arithmetic mean of a valid set of values of the water-vapour transmission rate, V , and, if required, the value of the water-vapour diffusion-equivalent air layer thickness, s_d , for the thickness determined;
- l) (if needed for calculations relating to construction applications) the value of the water-vapour resistance factor, μ , together with the associated film thickness, reported as a pair of values;

- m) any particular observations;
- n) details of any deviations from the test method specified;
- o) the name of the test laboratory in which the test was carried out and the name of the person who actually carried out the test;
- p) the date of the test.

Annex A (informative)

Derivation of Equation (8) in Subclause 8.3 for the calculation of the water-vapour diffusion-equivalent air layer thickness, s_d

The calculation of the water-vapour diffusion-equivalent air layer thickness, s_d , from the measured water-vapour transmission rate, V [Equation (8) in Subclause 8.3], is based on the following equations and definitions:

$$\delta_a \times d_a = \delta_c \times s_d \quad (\text{A.1})$$

s_d can therefore be expressed as follows:

$$s_d = \frac{\delta_a}{\delta_c} \times d_a \quad (\text{A.2})$$

where

- δ_a is the water-vapour permeation coefficient of air, in grams per metre per day per pascal;
- d_a is the thickness of the air layer (in this case 1 m);
- δ_c is the water-vapour permeation coefficient of the coating, in grams per metre per day per pascal;
- s_d is the water-vapour diffusion-equivalent air layer thickness of the coating, in metres.

The water-vapour permeation coefficient of air, δ_a , is a function of the diffusion coefficient of water vapour in air, D , the gas constant for water vapour, R_V , and the temperature, T , as given by Equation (A.3):

$$\delta_a = \frac{D}{R_V \times T} \quad (\text{A.3})$$

where

- R_V is the gas constant for water vapour, in newton metres per gram per Kelvin [$R_V = 0,462 \text{ N}\cdot\text{m}/(\text{g}\cdot\text{K})$];
- T is the mean value of the temperature, in kelvins, during the test [for the wet-cup (i.e. the reference) method, $T = 296 \text{ K}$ (= 23 °C)];
- D is the diffusion coefficient of water vapour in air, in square metres per day.

The diffusion coefficient of water vapour in air, D , is a function of the air temperature, T , during the test and can be calculated from Equation (A.4):

$$D = D_0 \times \left(\frac{T}{T_0} \right)^{1,81} \quad (\text{A.4})$$

where

- T_0 is the standard temperature, in kelvins (= 273 K);
- D_0 is the diffusion coefficient of water vapour in air at standard temperature and pressure [at 273 K and standard pressure (= 101 325 Pa), the value of D_0 is 1,996 m²/d].

The value of δ_a at $T = 296$ K and at standard pressure can be calculated from Equation (A.5):

$$\delta_a = \frac{D_0}{R_V \times T} \times \left(\frac{T}{T_0} \right)^{1,81} \quad (\text{A.5})$$

Substituting 1,996 m²/d for D_0 ,

0,462 N·m/(g·K) for R_V ,

296 K for T and

1,158 for $\left(\frac{T}{T_0} \right)^{1,81}$

gives

$$\delta_a = \frac{1,996}{0,462 \times 296} \times 1,158 = 0,0169 \text{ g/(m·d·Pa)}$$

The water-vapour permeation coefficient of the coating, δ_c , is a function of the water-vapour transmission rate, V , and the water-vapour partial-pressure difference, Δp_V , as given by Equation (A.6):

$$\delta_c = \frac{V}{\Delta p_V} \times d_a \quad (\text{A.6})$$

where

V is the water-vapour transmission rate of the coating, in grams per square metre per day;

Δp_V is the water-vapour partial-pressure difference between the two sides of the coating, in pascals;

d_a is the thickness of the air layer (in this case 1 m).

Combining Equation (A.6) with Equation (A.2) gives

$$s_d = \frac{\delta_a \times \Delta p_V}{V} \quad (\text{A.7})$$

Substituting 0,016 9 g/(m·d·Pa) for δ_a at $T = 296$ K in Equation (A.7) gives

$$s_d = \frac{0,0169 \times \Delta p_V}{V} \quad (\text{A.8})$$

For the dry-cup method, taking Δp_V as 1 400 Pa allows Equation (A.8) to be simplified to $s_d = \frac{23,7}{V}$.

For the wet-cup method, taking Δp_V as 1 207 Pa allows Equation (A.8) to be simplified to $s_d = \frac{20,4}{V}$.

Annex B (normative)

Use of molten wax for sealing the test assembly

B.1 General

If wax is used as the sealing material, it is essential that it adhere strongly to both the cup and the test piece. In addition, it is important that it be not brittle at the test temperature, not hygroscopic and not susceptible to oxidation. A surface of 50 cm² of freshly melted wax, when exposed for 24 h at 38 °C and 90 % relative humidity, shall not give a variation in mass of more than 1 mg. Wax mixtures that attack the test piece shall not be used.

Suitable wax compositions are:

- a) 60 % (by mass) microcrystalline wax and 40 % (by mass) refined crystalline paraffin wax;
- b) 80 % (by mass) paraffin wax with a melting point of 50 °C to 52 °C and 20 % (by mass) viscous-consistency polyisobutene (relatively low degree of polymerization);
- c) mixture of waxes melting over the range 60 °C to 75 °C and with an oil content of 1,5 % (by mass) to 3 % (by mass).

If the wax contains traces of water, these can be eliminated by heating to 105 °C to 110 °C and stirring.

The oil content of the microcrystalline wax shall be below 3 % (by mass) and that of the refined paraffin wax below 1 % (by mass).

It is advisable to use new wax to seal each test piece. However, if wax is reused, then care shall be taken to remove foreign bodies and impurities before use.

If the molten wax is allowed to spread on to the test area, this will reduce the effective area of the test piece and lead to erroneous results.

NOTE The apparatus and procedures used are similar to those described in ISO 2528.

B.2 Apparatus

The general requirements specified in 5.2 apply. Figure B.1 shows examples of apparatus which has proved satisfactory in use.

B.2.1 Circular non-porous cups, with a groove round the rim for sealing the test piece with wax. The groove shall have a profile such that the test piece can be sealed over the opening of the cup and that no water vapour can escape at or through the edges of the test piece.

The exact surface area to be exposed is defined by the diameter, D , of the waxing template (see B.2.2). The internal diameter of the rim of the cup on which the test piece rests shall be equal to or very slightly greater than the diameter, D .

B.2.2 Waxing templates, to control the application of the wax and to allow the test surface to be defined exactly. Their diameter, D , is the diameter of the exposed area of the test piece.

These templates may be

- a) cover templates (see Figure B.1) which shall be taken off when the hot wax has been run in and has cooled (they comprise discs with central handles, drilled with a small hole at a suitable point and having the edge

chamfered at an angle of approximately 45° in such a way that the smaller diameter is on the bottom — the diameter D is the diameter of this smaller circle);

or

- b) cross-braced ring templates (see Figure B.1) which remain in place during the test (as many ring templates as cups are required — the diameter D is the internal diameter of the ring).

Small guides may be fixed to the template to centre it automatically. A few templates are sufficient.

B.3 Procedure

B.3.1 General

Prepare the test pieces and cups as specified in 6.2 and 6.4, respectively.

NOTE The procedure for sealing the test piece to the cup is slightly different depending on whether a cover or ring template is used.

B.3.2 Use of cover templates

Fill the cup with saturated solution (5.3) or desiccant (5.4), as specified, to a level which is approximately 10 mm below the final position of the test piece. Place the test piece centrally in position, followed by the cover template. (To ensure that the cover template comes away easily, it is advisable previously to smear a thin film of petroleum jelly around the edge and to wipe away any excess which could contaminate the test piece.) Melt the wax, then run it into the annular cavity until it reaches the level of the upper surface of the cover template and, after cooling, complete the seal by carefully removing air bubbles and hairline cracks. A warm spatula may be run over the wax to assist in this process, so that any shrinkage cracks that might have developed during cooling will be closed. Remove the cover template and examine the assembly to make sure that the seal is satisfactory.

B.3.3 Use of ring templates

Melt the wax and run it into the circular groove round the cup until a slight meniscus is produced above the inner edge of the groove.

Fill the cup with the saturated solution (5.3) or desiccant (5.4), as specified, to a level which is approximately 10 mm below the final position of the test piece. Place the test piece centrally in position, followed by the ring template, and load the template with a mass of 1 kg.

Run more wax into the annular space so formed and, after cooling, complete the seal by carefully removing any air bubbles and hairline cracks. A warm spatula may be run over the wax to assist in this process, so that any shrinkage cracks that might have developed during cooling will be closed. Remove the mass and leave the ring in place.

Dimensions in millimetres

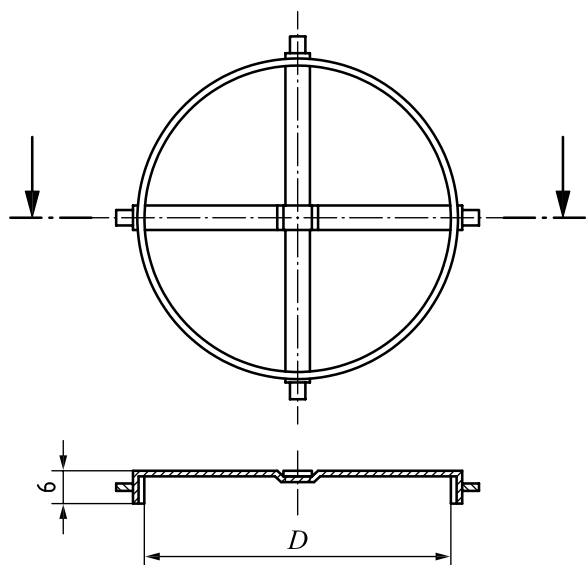

a) Ring template

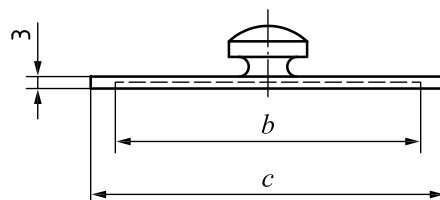

b) Cutting template

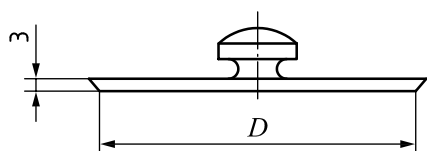

c) Cover template

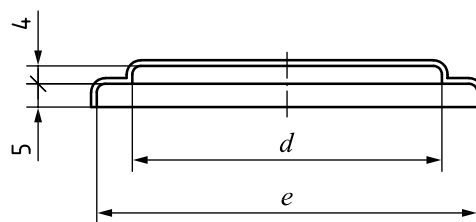

d) Lid with rim to fit outside dish
 (see Note to 6.4 for use of this assembly)

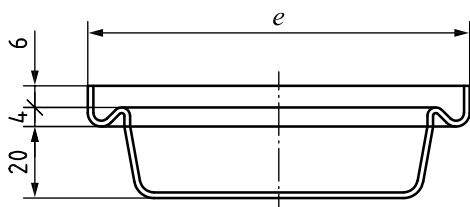

e) Deep dish

The values given in Table B.1 for the dimensions of the cups and lids shown in the figure are inside dimensions, except for the overall diameters of the cups, which are outside dimensions. Only dimension *D* needs to be strictly respected. The other dimensions are approximate.

Figure B.1 — Examples of circular test cups and templates

Table B.1 — Dimensions of test cups

Area of test piece <i>A</i> cm ²	Dimensions of test cup mm				
	<i>D</i>	<i>b</i>	<i>c</i>	<i>d</i>	<i>e</i>
10	35,7	35	45	30	50
15	43,7	45	55	40	60
20	50,5	50	60	45	65
25	56,4	55	65	50	70
50	79,8	80	90	75	95
100	112,8	115	125	110	130

Bibliography

- [1] ISO 483, *Plastics — Small enclosures for conditioning and testing using aqueous solutions to maintain the humidity at a constant value*
- [2] ISO 2528, *Sheet materials — Determination of water vapour transmission rate — Gravimetric (dish) method*
- [3] ISO 3270, *Paints and varnishes and their raw materials — Temperatures and humidities for conditioning and testing*
- [4] ISO 12572, *Hygrothermal performance of building materials and products — Determination of water vapour transmission properties*

British Standards Institution (BSI)

BSI is the national body responsible for preparing British Standards and other standards-related publications, information and services.

BSI is incorporated by Royal Charter. British Standards and other standardization products are published by BSI Standards Limited.

About us

We bring together business, industry, government, consumers, innovators and others to shape their combined experience and expertise into standards-based solutions.

The knowledge embodied in our standards has been carefully assembled in a dependable format and refined through our open consultation process. Organizations of all sizes and across all sectors choose standards to help them achieve their goals.

Information on standards

We can provide you with the knowledge that your organization needs to succeed. Find out more about British Standards by visiting our website at bsigroup.com/standards or contacting our Customer Services team or Knowledge Centre.

Buying standards

You can buy and download PDF versions of BSI publications, including British and adopted European and international standards, through our website at bsigroup.com/shop, where hard copies can also be purchased.

If you need international and foreign standards from other Standards Development Organizations, hard copies can be ordered from our Customer Services team.

Subscriptions

Our range of subscription services are designed to make using standards easier for you. For further information on our subscription products go to bsigroup.com/subscriptions.

With **British Standards Online (BSOL)** you'll have instant access to over 55,000 British and adopted European and international standards from your desktop. It's available 24/7 and is refreshed daily so you'll always be up to date.

You can keep in touch with standards developments and receive substantial discounts on the purchase price of standards, both in single copy and subscription format, by becoming a **BSI Subscribing Member**.

PLUS is an updating service exclusive to BSI Subscribing Members. You will automatically receive the latest hard copy of your standards when they're revised or replaced.

To find out more about becoming a BSI Subscribing Member and the benefits of membership, please visit bsigroup.com/shop.

With a **Multi-User Network Licence (MUNL)** you are able to host standards publications on your intranet. Licences can cover as few or as many users as you wish. With updates supplied as soon as they're available, you can be sure your documentation is current. For further information, email bsmusales@bsigroup.com.

BSI Group Headquarters

389 Chiswick High Road London W4 4AL UK

Revisions

Our British Standards and other publications are updated by amendment or revision.

We continually improve the quality of our products and services to benefit your business. If you find an inaccuracy or ambiguity within a British Standard or other BSI publication please inform the Knowledge Centre.

Copyright

All the data, software and documentation set out in all British Standards and other BSI publications are the property of and copyrighted by BSI, or some person or entity that owns copyright in the information used (such as the international standardization bodies) and has formally licensed such information to BSI for commercial publication and use. Except as permitted under the Copyright, Designs and Patents Act 1988 no extract may be reproduced, stored in a retrieval system or transmitted in any form or by any means – electronic, photocopying, recording or otherwise – without prior written permission from BSI. Details and advice can be obtained from the Copyright & Licensing Department.

Useful Contacts:

Customer Services

Tel: +44 845 086 9001

Email (orders): orders@bsigroup.com

Email (enquiries): cservices@bsigroup.com

Subscriptions

Tel: +44 845 086 9001

Email: subscriptions@bsigroup.com

Knowledge Centre

Tel: +44 20 8996 7004

Email: knowledgecentre@bsigroup.com

Copyright & Licensing

Tel: +44 20 8996 7070

Email: copyright@bsigroup.com



...making excellence a habit.™