

BS EN ISO 7494-2:2015



BSI Standards Publication

Dentistry — Dental units

Part 2: Air, water, suction and wastewater systems (ISO 7494-2:2015)

bsi.

...making excellence a habit.™

National foreword

This British Standard is the UK implementation of EN ISO 7494-2:2015. It supersedes BS EN ISO 11144:1997 and BS EN ISO 7494-2:2003 which are withdrawn.

The UK participation in its preparation was entrusted to Technical Committee CH/106/4, Dental Instruments and Equipment.

A list of organizations represented on this committee can be obtained on request to its secretary.

This publication does not purport to include all the necessary provisions of a contract. Users are responsible for its correct application.

© The British Standards Institution 2015. Published by BSI Standards Limited 2015

ISBN 978 0 580 78985 4

ICS 11.060.20

Compliance with a British Standard cannot confer immunity from legal obligations.

This British Standard was published under the authority of the Standards Policy and Strategy Committee on 30 April 2015.

Amendments issued since publication

Date	Text affected
------	---------------

English Version

**Dentistry - Dental units - Part 2: Air, water, suction and
wastewater systems (ISO 7494-2:2015)**

Médecine bucco-dentaire - Units dentaires - Partie 2:
Systèmes d'alimentation en air et en eau, d'aspiration et
d'évacuation des eaux usées (ISO 7494-2:2015)

Zahnheilkunde - Zahnärztliche Behandlungseinheiten - Teil
2: Luft, Wasser, Absaugung und Abwassersystem (ISO
7494-2:2015)

This European Standard was approved by CEN on 10 January 2015.

CEN members are bound to comply with the CEN/CENELEC Internal Regulations which stipulate the conditions for giving this European Standard the status of a national standard without any alteration. Up-to-date lists and bibliographical references concerning such national standards may be obtained on application to the CEN-CENELEC Management Centre or to any CEN member.

This European Standard exists in three official versions (English, French, German). A version in any other language made by translation under the responsibility of a CEN member into its own language and notified to the CEN-CENELEC Management Centre has the same status as the official versions.

CEN members are the national standards bodies of Austria, Belgium, Bulgaria, Croatia, Cyprus, Czech Republic, Denmark, Estonia, Finland, Former Yugoslav Republic of Macedonia, France, Germany, Greece, Hungary, Iceland, Ireland, Italy, Latvia, Lithuania, Luxembourg, Malta, Netherlands, Norway, Poland, Portugal, Romania, Slovakia, Slovenia, Spain, Sweden, Switzerland, Turkey and United Kingdom.



EUROPEAN COMMITTEE FOR STANDARDIZATION
COMITÉ EUROPÉEN DE NORMALISATION
EUROPÄISCHES KOMITEE FÜR NORMUNG

CEN-CENELEC Management Centre: Avenue Marnix 17, B-1000 Brussels

Foreword

This document (EN ISO 7494-2:2015) has been prepared by Technical Committee ISO/TC 106 "Dentistry" in collaboration with Technical Committee CEN/TC 55 "Dentistry" the secretariat of which is held by DIN.

This European Standard shall be given the status of a national standard, either by publication of an identical text or by endorsement, at the latest by October 2015, and conflicting national standards shall be withdrawn at the latest by October 2015.

Attention is drawn to the possibility that some of the elements of this document may be the subject of patent rights. CEN [and/or CENELEC] shall not be held responsible for identifying any or all such patent rights.

This document supersedes EN ISO 7494-2:2003 and EN ISO 11144:1996.

According to the CEN-CENELEC Internal Regulations, the national standards organizations of the following countries are bound to implement this European Standard: Austria, Belgium, Bulgaria, Croatia, Cyprus, Czech Republic, Denmark, Estonia, Finland, Former Yugoslav Republic of Macedonia, France, Germany, Greece, Hungary, Iceland, Ireland, Italy, Latvia, Lithuania, Luxembourg, Malta, Netherlands, Norway, Poland, Portugal, Romania, Slovakia, Slovenia, Spain, Sweden, Switzerland, Turkey and the United Kingdom.

Endorsement notice

The text of ISO 7494-2:2015 has been approved by CEN as EN ISO 7494-2:2015 without any modification.

Contents

Page

Foreword	v
Introduction	vi
1 Scope	1
2 Normative references	1
3 Terms and definitions	1
4 Classification	4
4.1 Classification of suction systems.....	4
4.2 Classification of suction air volume flow rate.....	4
5 Requirements	4
5.1 Requirements for supply connections.....	4
5.2 Requirements for water and wastewater systems.....	4
5.2.1 Incoming water.....	5
5.2.2 Materials used for construction of procedural water systems within the dental unit.....	6
5.2.3 Backflow prevention device for dental units connected to the external drinking water supply.....	7
5.2.4 Cuspidors.....	7
5.2.5 Water venturi.....	7
5.2.6 Particle filter.....	7
5.2.7 Bacterial filter.....	7
5.2.8 Bottled water system supplying procedural water or solution.....	7
5.2.9 Retraction.....	7
5.2.10 Water disinfection systems.....	7
5.2.11 Water sampling connection point.....	8
5.2.12 Wastewater drain connection.....	8
5.3 Requirements for the air system.....	8
5.3.1 Incoming air (dental air).....	8
5.3.2 Particle filters.....	8
5.3.3 Bacterial filters.....	9
5.4 Requirements for dental unit suction systems.....	9
5.4.1 Static vacuum pressure.....	9
5.4.2 Head loss.....	9
5.4.3 Air separators.....	9
5.4.4 Cannula connectors and cannula.....	9
5.4.5 Operating hoses with cannula connectors.....	10
5.4.6 Solids filter.....	11
5.4.7 Noise level.....	11
5.4.8 Dental unit suction source connection point.....	11
6 Sampling	11
7 Tests	11
7.1 Cuspidors.....	11
7.2 Water venturi.....	11
7.3 Systems directly connected to external drinking water supply.....	11
7.4 Bottled water system supplying procedural water or solution.....	11
7.5 Retraction.....	12
7.6 Particle filters.....	12
7.7 Bacterial filters.....	12
7.8 Water disinfection systems.....	12
7.9 Tests for dental unit suction systems.....	13
7.9.1 Static vacuum pressure test.....	13
7.9.2 Head loss test.....	13
7.9.3 Measurement of noise level.....	14

7.10	Water sampling connection point.....	15
7.11	Incoming water and air quality	15
7.12	Supply connections	15
8	Manufacturer's instructions for use.....	15
9	Technical description	16
Annex A	(informative) Schematic diagram of possible components and connections in a dental unit.....	18
Annex B	(informative) Test sequences	20
Bibliography	25

Foreword

ISO (the International Organization for Standardization) is a worldwide federation of national standards bodies (ISO member bodies). The work of preparing International Standards is normally carried out through ISO technical committees. Each member body interested in a subject for which a technical committee has been established has the right to be represented on that committee. International organizations, governmental and non-governmental, in liaison with ISO, also take part in the work. ISO collaborates closely with the International Electrotechnical Commission (IEC) on all matters of electrotechnical standardization.

The procedures used to develop this document and those intended for its further maintenance are described in the ISO/IEC Directives, Part 1. In particular the different approval criteria needed for the different types of ISO documents should be noted. This document was drafted in accordance with the editorial rules of the ISO/IEC Directives, Part 2 (see www.iso.org/directives).

Attention is drawn to the possibility that some of the elements of this document may be the subject of patent rights. ISO shall not be held responsible for identifying any or all such patent rights. Details of any patent rights identified during the development of the document will be in the Introduction and/or on the ISO list of patent declarations received (see www.iso.org/patents).

Any trade name used in this document is information given for the convenience of users and does not constitute an endorsement.

For an explanation on the meaning of ISO specific terms and expressions related to conformity assessment, as well as information about ISO's adherence to the WTO principles in the Technical Barriers to Trade (TBT) see the following URL: [Foreword - Supplementary information](#)

The committee responsible for this document is ISO/TC 106, *Dentistry*, Subcommittee SC 6, *Dental equipment*.

This edition of ISO 7494-2 cancels and replaces ISO 7494-2:2003 and ISO 11144, of which it constitutes a technical revision, while only replacing certain requirements specific to dental units given in ISO 10637. In addition, it consolidates and updates requirements formerly specified in

- ISO 10637:1999, *Dental equipment — High- and medium-volume suction systems*, and
- ISO 11144:1995, *Dental equipment — Connections for supply and waste lines*.

ISO 7494 consists of the following parts, under the general title *Dentistry — Dental units*:

- *Part 1: General requirements and test methods*
- *Part 2: Air, water, suction and wastewater systems*

Introduction

This part of ISO 7494 specifies requirements and test methods pertaining to components of the dental unit which convey air, water, suction, and wastewater. The requirements in this part of ISO 7494 focus on certain technical aspects regarded by the working group to be appropriate for international standardization. The working group acknowledges that requirements for microbiological aspects of the fluids transported by dental units are also worthy of standardization and is working to develop requirements pertaining to the prevention, inhibition, and removal of dental unit waterline biofilm. Additional projects to develop microbiological requirements for air, water, and/or suction may follow.

Dentistry — Dental units —

Part 2:

Air, water, suction and wastewater systems

1 Scope

This part of ISO 7494 specifies requirements and test methods concerning

- a) the configuration of dental unit connections to the compressed air supply, water supply, suction supply, and wastewater drain plumbing,
- b) the materials, design, and construction of the compressed air and water system within the dental unit,
- c) the quality for incoming water and air, and
- d) the performance of dental unit suction system.

This part of ISO 7494 also specifies requirements for instructions for use and technical description.

This part of ISO 7494 is limited to dental units that are not used for life support treatment of ambulatory patients or for oral surgery treatment requiring sterile air and water supplies. Amalgam separators are not included in this International Standard.

2 Normative references

The following documents, in whole or in part, are normatively referenced in this document and are indispensable for its application. For dated references, only the edition cited applies. For undated references, the latest edition of the referenced document (including any amendments) applies.

ISO 1942, *Dentistry — Vocabulary*

ISO 7494-1:2011, *Dentistry — Dental units — Part 1: General requirements and test methods*

ISO 8573-1, *Compressed air — Part 1: Contaminants and purity classes*

ISO 9168, *Dentistry — Hose connectors for air driven dental handpieces*

ISO 10637:1999, *Dental equipment — High- and medium-volume suction systems*

ISO 14971, *Medical devices — Application of risk management to medical devices*

IEC 61672-1, *Electroacoustics — Sound level meters — Part 1: Specifications*

IEC 62366, *Medical devices — Application of usability engineering to medical devices*

3 Terms and definitions

For the purposes of this document, the terms and definitions given in ISO 1942 and ISO 7494-1 and the following apply.

3.1

air separator

apparatus which separates liquids and solids from the suction air

3.2

bacterial filter

filter designed to restrict the passage of bacteria and reduce bacteria in the procedural water or in the compressed air

3.3

backflow

flow of water and/or another medium back into the external drinking water supply

3.4

backflow prevention device

safety device to prevent backflow

3.5

bottled water system

dental unit water system in which procedural water is supplied by an included reservoir which is not connected to an external drinking water supply system and is manually filled with incoming water or incoming solution

3.6

cannula connector

component at the end of the dental suction operating hose, which joins the cannula to the operating hose

3.7

dental air

compressed air supplied through the dental unit for powering, controlling, and/or assisting various dental instruments and equipment, as well as for assisting practitioners with procedures in the oral cavity, but not for procedures requiring medical air or sterile air, such as endoscopy, oral surgery, analgesia, and life support

3.8

dental treatment centre

combination of functional items for dental use which consist, for example, of dental unit, dental patient chair, and interconnected sub-units of dental equipment and instruments providing a functional environment for dental care

3.9

dental unit suction system

passive entity, including all the components from the dental unit suction source connection point through the cannula connector, which can induce air flow when connected to a suction source to evacuate solids, liquids, aerosols and gases from the oral cavity and immediate surrounding area during oral treatment procedures

3.10

dental unit suction source connection point

any port on the dental unit for connection to a supply of dental suction

3.11

filter

apparatus which restricts targeted constituents from passing through it

3.12

incoming air

compressed air supplied to the dental unit

3.13

incoming air connection point

any port on the dental unit for connection to an external compressed air supply

3.14

incoming solution

solution of substances specified by the manufacturer, and introduced in combination with, or in place of, the incoming water in order to improve or maintain the quality of the procedural water or for other reasons, such as coolant for cutting burs or medicament for oral cavity

3.15

incoming water

water supplied to the dental unit for procedural use or non-procedural use

3.16

incoming water connection point

any port on the dental unit for connection to an external drinking water supply

3.17

non-procedural water

water supplied by the dental unit for purposes other than use in the oral cavity

EXAMPLE Cuspidor bowl rinse water, water venturi supply water.

3.18

procedural water

water supplied by the dental unit for use in the oral cavity

EXAMPLE Handpiece coolant water, multifunction handpieces (syringes) water, scaler coolant water, cup fill water.

3.19

retraction

re-entry of water, air, and/or other medium into the dental unit or the dental instruments due to flow reversal, e.g. caused by momentary dynamic pressure variations during turning off the instruments

3.20

rinse water

water for cleaning

3.21

spill-over level

highest possible level of water or solution in a device above which the fluid will flow over the edge

3.22

suction system

active entity of dental equipment, including a suction source equipment, which enables an air flow to be induced which is designed to remove spray, liquids, and solids from the mouth of the dental patient during dental treatment

3.23

wastewater

solution that is discharged into the drainage system by way of the cuspidor drain, saliva ejector, air separator, amalgam separator, or other dental unit component or system

3.24

water disinfection system

system designed to reduce the microbiological contamination in a dental unit procedural water

3.25

water venturi

device using waterflow to produce a suction

3.26

wastewater connection point

port for the connection through which wastewater flows and is discharged into the drains

4 Classification

4.1 Classification of suction systems

According to ISO 10637:1999, suction systems are classified to the type of suction as follows:

- a) dry system;
- b) semi-dry system;
- c) wet system.

4.2 Classification of suction air volume flow rate

According to ISO 10637:1999, suction systems are classified to the type of air volume flow rate as follows:

- a) type 1: high-volume suction system, suction system with an air intake of more than 250 Nl/min¹⁾ at the suction cannula connector;
- b) type 2: medium-volume suction system, suction system with an air intake between 90 Nl/min and 250 Nl/min¹⁾ at the suction cannula connector.

5 Requirements

5.1 Requirements for supply connections

The manufacturer's technical description shall include the configuration of the supply connections for the dental unit. The specified configuration of the supply connections shall lie within a maximum area of 180 mm × 220 mm.

The manufacturer's technical description shall include detailed information of the position and the dimensions of supply connections (see keys 1 to 5 in [Figure 1](#)) for the dental unit in the dental treatment centre.

In the dental treatment centre, often a core hole in the floor with a diameter of 160 mm is used. Therefore, it is recommended to place the supply connections within this diameter.

An example of the configuration and the connection points is given in [Figure 1](#).

Dimensions for the connections for electricity and compressed air areas (see keys 4 and 5 in [Figure 1](#)) are given as maximum values.

Dimensions for plumbing holes (see keys 1, 2, and 3 in [Figure 1](#)) are given as minimum values. The diameters specify the free space required for tubes and hoses.

The holes without dimensions can be positioned anywhere inside the connection area.

Gas tubing, if required, shall not be located inside the areas specified in [Figure 1](#).

The location of other utility connections which are not indicated shall be specified by the manufacturer.

This test is in accordance with [7.12](#).

5.2 Requirements for water and wastewater systems

NOTE A schematic diagram of possible water and wastewater systems is given as example in Figure A.1.

1) Nl/min indicates *normal litres per minute*, the amount of air that flows through a pipe calculated back to "normal" conditions [0 °C and 1 atm or 1,01325 bar (1 bar = 0,1 MPa = 0,1 N/mm² = 10⁵ N/m²)].

5.2.1 Incoming water

The manufacturer's instructions for use and technical description shall specify the requirements for the incoming water to be supplied to the dental unit, including the following parameters.

The following values are recommendations:

- a) water pressure limits (2 bar to 6 bar);
- b) water flow rate limit (greater than 5 l/min);
- c) water hardness limit [less than 2,14 mmol/l (<12 °dH)];
- d) pH limits (6,5 to 8,5);
- e) maximum particle size (<100 µm);
- f) conformance to local drinking water regulations.

This test is in accordance with [7.11](#).

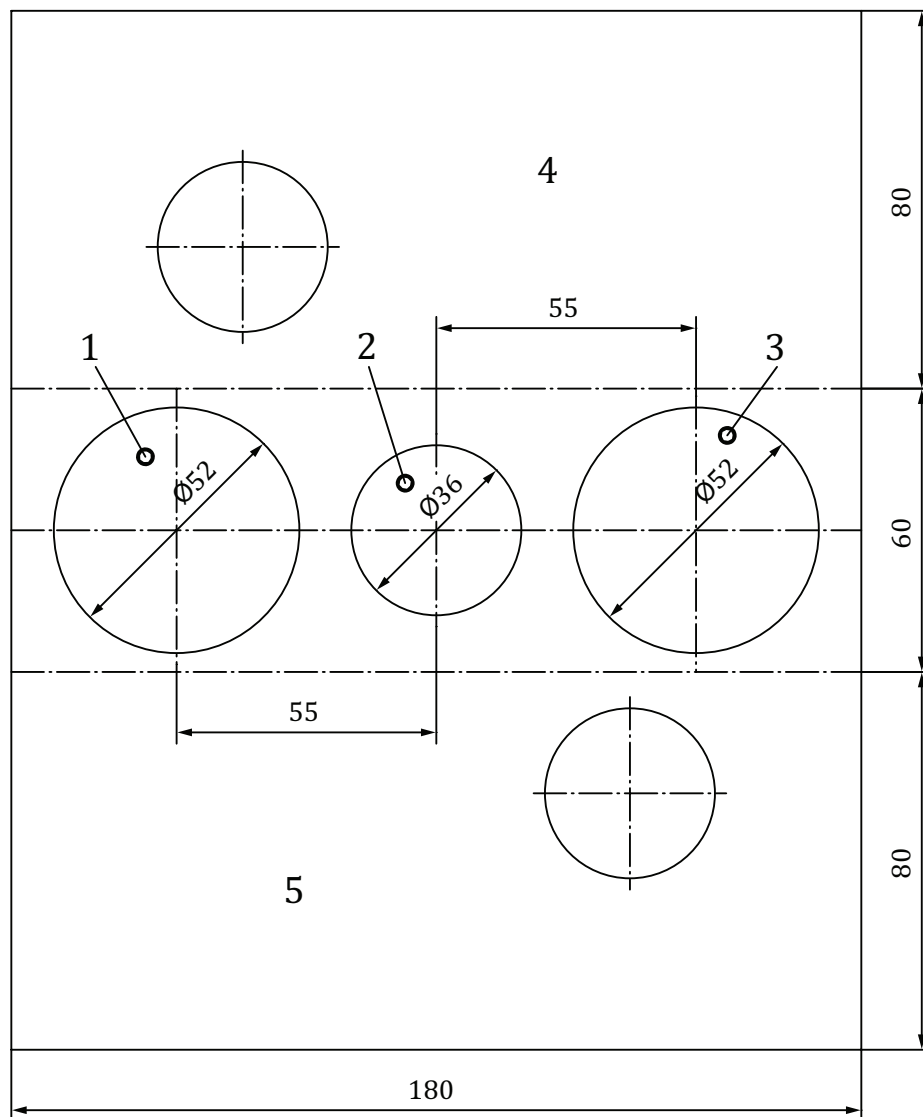

Key

- 1 wastewater connection point
- 2 incoming water connection point
- 3 dental unit suction source connection point
- 4 connection area for electricity and telecommunication
- 5 connection area for incoming air

Figure 1 — Configuration example of connection points and adjacent supply areas

5.2.2 Materials used for construction of procedural water systems within the dental unit

The dental unit shall be designed and constructed in such a way that the materials which come into contact with the procedural water or solutions or that are likely to come into contact with them do not cause an unacceptable risk to the quality of the procedural water or solution.

The materials used within the water path shall be documented by the manufacturer. The materials used shall be evaluated by risk analysis to ensure that they do not cause an unacceptable risk to the quality of procedural water or solution.

Manufacturers shall document this risk analysis in accordance with ISO 14971.

5.2.3 Backflow prevention device for dental units connected to the external drinking water supply

Dental units directly connected to the external drinking water supply system and using this water as procedural water shall have a backflow prevention device at the connection point with the water supply or an air gap of not less than 20 mm.

This test is in accordance with [7.3](#).

5.2.4 Cuspidors

The point where the cuspidor rinse water is dispensed shall be at least 20 mm above the spill-over level of the cuspidor.

This test is in accordance with [7.1](#).

5.2.5 Water venturi

Water venturi for suction of saliva and wastewater shall only be used if an additional backflow prevention device is installed at the connection point of the water venturi device.

This test is in accordance with [7.2](#).

5.2.6 Particle filter

A dental unit directly connected to an external drinking water supply or a bottled water system shall have at least one particle filter with an effective mesh size not greater than 100 µm installed at the incoming water connection point.

This test is in accordance with [7.6](#).

5.2.7 Bacterial filter

If the dental unit water supply is equipped with a filter intended to restrict the passage of bacteria, the bacterial filter shall be rated to restrict the passage of contaminants larger than 0,22 µm. The dental unit manufacturer shall provide maintenance instructions and schedule for the bacterial filter.

This test is in accordance with [7.7](#).

5.2.8 Bottled water system supplying procedural water or solution

These systems shall either be completely separated from the external drinking water supply system or shall have a backflow prevention device at the connection point with the external drinking water supply system.

This test is in accordance with [7.4](#).

5.2.9 Retraction

The volume of the retraction of procedural water or solution shall not exceed 40 mm³ (= 0,04 ml).

This test is in accordance with [7.5](#).

5.2.10 Water disinfection systems

These systems shall either be completely separated from the external drinking water supply system or shall have a backflow prevention device at the connection point with the external drinking water supply system.

The manufacturer shall supply information about the water disinfection solution and instructions for use and maintenance.

The manufacturer shall ensure that the use of these chemicals does not adversely affect the water quality and shall specify the recommended maintenance frequency.

If a water disinfection system is installed in a dental unit, it shall be tested in accordance with [7.8](#).

5.2.11 Water sampling connection point

For dental units directly connected to the external drinking water supply, the manufacturer's technical description should include a recommendation to install a sampling point for incoming water at or near the incoming water connection point.

NOTE See [Figure A.1](#), key 25.

If the manufacturer recommends installing a sampling point, the instructions for use shall give information about collecting samples of water and the technical description shall provide information about the installation and collection of water samples.

This test is in accordance with [7.10](#).

5.2.12 Wastewater drain connection

The manufacturer's technical description shall specify the maximum wastewater flow rate from the dental unit that the drain shall be capable of accommodating.

The manufacturer's technical description shall specify the minimum gradient of the wastewater lines.

Check the technical description to ensure that all information specified is provided.

5.3 Requirements for the air system

NOTE A schematic diagram of possible air connections in dental units is given as example in [Figure A.1](#).

5.3.1 Incoming air (dental air)

The manufacturer's instructions for use and the technical description shall specify requirements for the incoming air to be supplied to the dental unit, including the following parameters.

The following values are recommendations:

- a) air pressure limits (7 ± 1) bar;
- b) air flow rate limit (greater than 80 l/min);
- c) humidity limit (dew point not greater than -20 °C at atmospheric pressure);
- d) oil contamination limit (max. 0,5 mg/m³);
- e) particulate contamination limit (not greater than 100 particles per cubic meter for 1 µm to 5 µm particle size).

This test is in accordance with [7.11](#) and shall conform to ISO 8573-1.

5.3.2 Particle filters

A filter with an effective mesh size not exceeding 50 µm shall be installed at the incoming air connection point of the dental unit.

This test is in accordance with [7.6](#).

5.3.3 Bacterial filters

If the dental unit air supply is equipped with a filter intended to restrict the passage of bacteria, the bacterial filter shall be rated to restrict the passage of contaminants larger than 0,22 µm. The dental unit manufacturer shall provide maintenance instructions and schedule for the bacterial filter.

This test is in accordance with [7.7](#).

5.4 Requirements for dental unit suction systems

NOTE A schematic diagram of possible suction connections in dental units is given as example in [Figure A.1](#).

5.4.1 Static vacuum pressure

The manufacturer of the dental unit shall specify the minimum and the maximum vacuum pressure that is to be supplied to the dental unit at the suction connection point under static (i.e. no flow) conditions in the technical description.

If the dental unit is equipped with a vacuum-limiting device, the manufacturer shall specify the maximum vacuum pressure available at the cannula connector under static conditions.

The dental unit suction systems shall withstand the maximum vacuum pressure supplied to the dental unit per manufacturer specifications without damage to its materials or components.

This test is in accordance with [7.9.1](#).

5.4.2 Head loss

The manufacturer shall measure and report in the technical description the pressure head loss between the dental unit suction source connection point and the atmospheric end of the cannula (with cannula recommended by the dental unit manufacturer installed) at each of the following flow rates:

90 NI/min, 150 NI/min, 200 NI/min, 250 NI/min, 300 NI/min, 350 NI/min, and 400 NI/min²⁾.

Measurements are not required at flow rates which require the vacuum pressure to exceed the maximum pressure specified by the manufacturer. Results at additional flow rates may be reported at the manufacturer's discretion in the technical description.

Measurements shall be made in accordance with [7.9.2](#).

NOTE This information helps parties responsible for specifying complete suction systems (i.e. suction source equipment, piping systems, and dental unit suction systems) to meet the flow performance requirements specified by a dental clinic.

5.4.3 Air separators

Maintenance of air separators shall conform to IEC 62366.

5.4.4 Cannula connectors and cannula

5.4.4.1 Cannula connector manufacturers shall state a nominal size of the connector and specify the requirements for cannula that can be used with the connector.

5.4.4.2 Cannula connectors shall allow access of the cannula to every part of the patient's mouth without causing distortion of the hoses.

2) NI/min indicates *normal litres per minute*, the amount of air that flows through a pipe calculated back to "normal" conditions [0 °C and 1 atm or 1,01325 bar (1 bar = 0,1 MPa = 0,1 N/mm² = 10⁵ N/m²)].

5.4.4.3 The forces to insert and remove the cannula from the cannula connector shall conform to IEC 62366 when the connector is used with cannula that meet the connector manufacturer's cannula requirements.

5.4.4.4 The design of the connection between the cannula and cannula connector shall be at the discretion of the manufacturer. An example of a connection design is provided in Figure 2 and Table 1.

Dimensions in millimetres

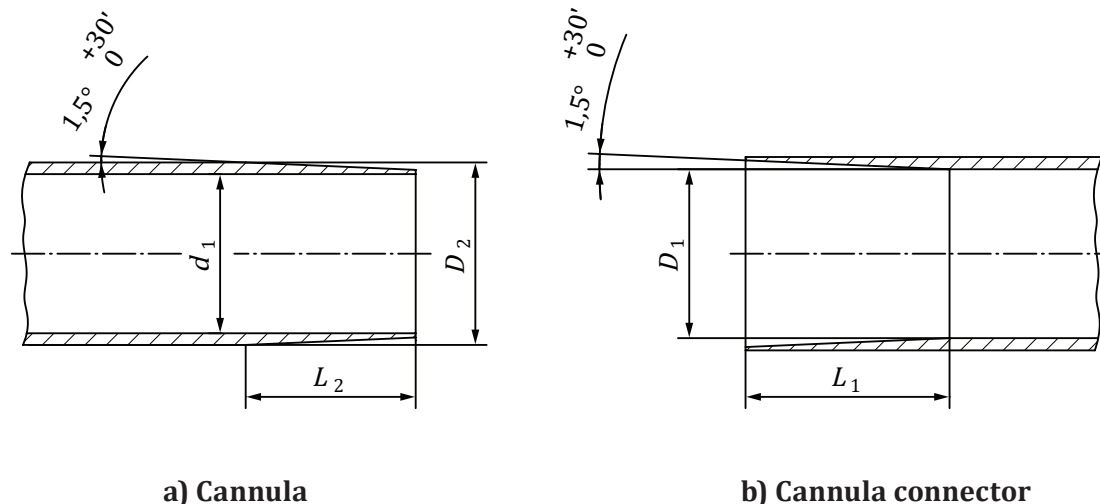

Key

- d_1 nominal inside diameter cannula
- D_1 inside diameter cannula connector
- D_2 outside diameter cannula
- L_1 inside taper length cannula connector
- L_2 outside taper length cannula

Figure 2 — Example of design of interface between cannula and cannula connector

Table 1 — Example of dimensions of interface between cannula and cannula connector

Dimensions in millimetres

d_1	D_1	D_2	L_1	L_2
15 ± 1	$14,9 + 0,2$	$16,1 - 0,2$	$18 - 1$	$15 - 1$
11 ± 1	$10,9 + 0,2$	$12,1 - 0,2$	$18 - 1$	$15 - 1$
≥ 6 for medium-volume suction system	Dimensions and tolerances given by the manufacturer			

Compliance shall be verified using readily available measuring instruments.

5.4.5 Operating hoses with cannula connectors

Operating hoses shall have an internally smooth surface and shall be flexible.

Operating hoses should be easily cleaned by methods and with agents recommended by the dental unit manufacturer.

Compliance shall be verified by visual inspection and shall conform to IEC 62336.

5.4.6 Solids filter

Solids filter for suction systems shall be located at the dental unit in such a way to allow easy removal for maintenance.

If an air separator is included in the dental unit, the solids filter shall be placed to ensure proper function of the air separator.

The solids filter shall have a mesh size determined by the manufacturer and specified in the instructions for use and in the technical description.

Compliance of the solids filter location shall be verified by visual inspection.

5.4.7 Noise level

The A-weighted noise level generated by high-volume and medium-volume suction systems through the connected cannula shall not exceed 65 dB (A) at a distance of 0,50 m from the cannula connector and with the cannula recommended by the manufacturer of the dental unit.

Testing shall be carried out in accordance with [7.9.3](#).

5.4.8 Dental unit suction source connection point

The manufacturer's technical description shall include the connection dimensions.

Check the technical description to ensure that all information specified is provided.

6 Sampling

One representative sample of the dental unit water and air supply and suction systems being tested shall be selected.

7 Tests

7.1 Cuspidors

Check by visual inspection whether the rinse water is dispersed above the spill-over level of the wastewater. Then, measure the distance of the air gap between the lowest point of the rinse water outlet and the spill-over level with a readily available measuring device.

7.2 Water venturi

Check by visual inspection that a backflow prevention device is installed at the connection point of the water venturi device.

7.3 Systems directly connected to external drinking water supply

Check by visual inspection whether a backflow prevention device or an air gap is installed at the incoming water connection point. Measure the distance of the air gap with a measuring device.

7.4 Bottled water system supplying procedural water or solution

Check by visual inspection if the bottled water system is separated from the external drinking water supply. If not, check by visual inspection if a backflow prevention device is installed at the incoming water connection point.

7.5 Retraction

Connect the handpiece hose to the dental unit. Then connect a transparent hose of ($L = 150 \pm 2$) mm length and ($d = 1,5 \pm 0,1$) mm internal diameter to the water fitting to which the handpiece is normally attached.

Measure the volume of retraction in the transparent hose.

The unconnected end of the transparent hose shall be squared off.

Operate the dental unit's valve as it would normally be done when activating the water flow for the handpiece to ensure that the vertically held hose is completely filled. Operate the dental unit's water valve as it would normally be done when shutting off the handpiece. The meniscus of the column of water in the hose shall not be more than a distance of $l = 20$ mm from the end of the hose when held vertically, with the open hose end extending upward. See [Figure 3](#).

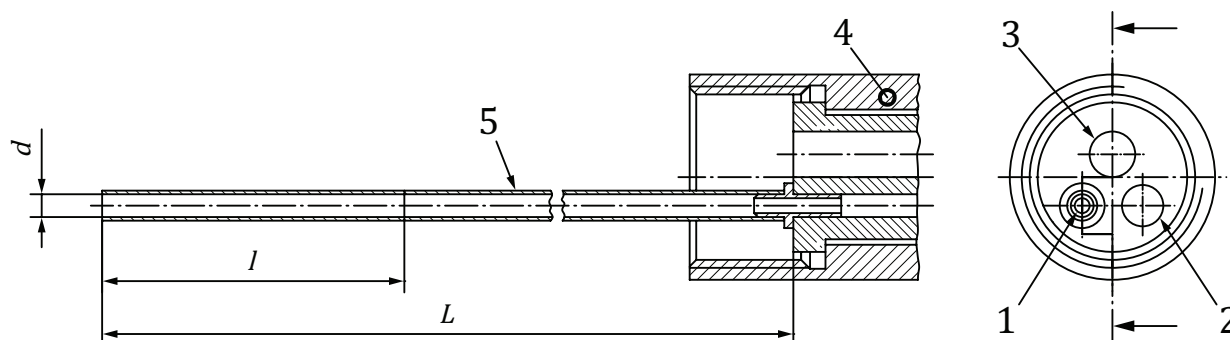

Key

- 1 water
- 2 exhaust
- 3 drive air
- 4 example of the type 4 connector from ISO 9168
- 5 transparent hose

Figure 3 — Configuration of retraction test apparatus in connection with a hose connector type 4

7.6 Particle filters

Check by visual inspection whether a particle filter is installed at the incoming water and/or air connection points. Check the instruction for use and the technical description to ensure that all information specified is provided, including information on the size of the filter mesh.

Check if the specified filter size meets the filter size requirement for water particle filters in [5.2.6](#) or for air particle filters in [5.3.2](#).

7.7 Bacterial filters

Check by visual inspection whether bacterial filters are installed. Check the instruction for use and the technical description to ensure that all information specified is provided.

7.8 Water disinfection systems

Check by visual inspection whether water disinfection systems are installed. Check the instructions for use to ensure that all information specified is provided.

7.9 Tests for dental unit suction systems

Perform all testing at an ambient temperature of (23 ± 2) °C. Condition all test samples at ambient temperature for at least 4 h.

The connections of all measuring devices shall be leak-free.

Measure the vacuum pressures with a gauge having a measurement tolerance not greater than ± 5 %.

7.9.1 Static vacuum pressure test

Connect a pressure gauge at the suction connection point capable of measuring the maximum vacuum supply pressure specified by the dental unit manufacturer.

Plug or seal all cannula connectors in a leak-free manner.

If the dental unit is equipped with a vacuum-limiting device, connect a second pressure gauge at the cannula connector on one of the operating hoses. Connect the second pressure gauge in a manner which allows it to measure the pressure within the suction system while the flow through the cannula connector is completely blocked.

Connect a suction source to the suction connection point and operate at the maximum vacuum pressure specified by the manufacturer, as measured by the pressure gauge at the suction connection point.

If the dental unit is equipped with a vacuum-limiting device, allow it to operate normally. Check whether the pressure at the cannula connector does not exceed the maximum pressure specified by the manufacturer.

Maintain the maximum specified static vacuum pressure for 1 h. Then, turn off the suction source and examine all components of the dental unit suction system for damage.

7.9.2 Head loss test

7.9.2.1 Apparatus

The test apparatus shall include the following as depicted in [Figure 4](#):

- a) suction source;
- b) flow throttling valve (such as a common ball valve);
- c) suction source pressure gauge capable of ± 5 % accuracy traceable to an international or national standard, plus necessary items to connect the gauge to the dental unit suction connection point in a manner that has negligible impact on pressure readings and flow;
- d) flow measuring device capable of ± 5 % accuracy traceable to an international or national standard that will impact the measured flow by no more than 5 %;
- e) pressure gauge for measuring atmospheric pressure.

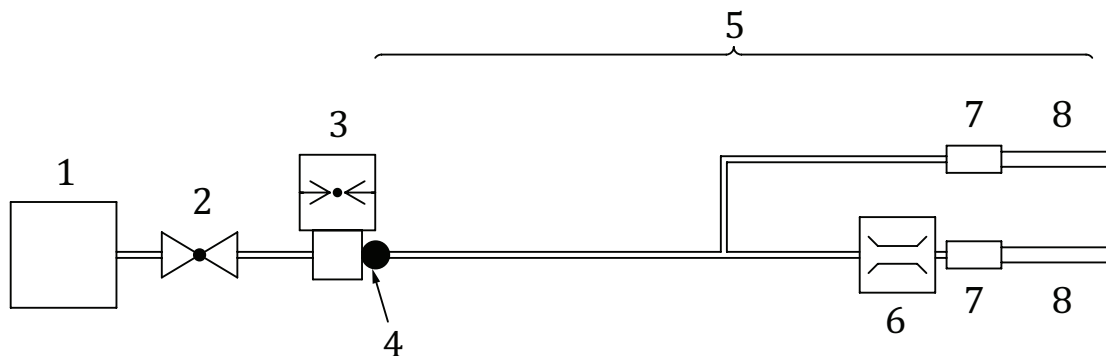

Key

- 1 suction source
- 2 flow throttling valve
- 3 suction source pressure gauge assembly
- 4 dental unit suction source connection point
- 5 dental unit suction system
- 6 flow measuring device
- 7 cannula connector
- 8 cannula

Figure 4 — Configuration of typical head loss test apparatus

7.9.2.2 Procedure

Install the suction source pressure gauge assembly to the dental unit suction source connection point. Connect the throttling valve on the inlet of the suction source gauge assembly. Connect the suction source device to the inlet of the throttling valve.

Install the flow measuring device at a point at which it is capable of measuring flow through one of the operating hoses with any flow control attached to that hose set fully open. Insert the manufacturer's recommended standard cannula into the cannula connector.

Any additional operating hoses shall be either unobstructed or shut off, according to the manufacturer's instructions for normal use.

Turn on the suction source device and adjust the throttling valve until the measuring device indicates the required flow rate.

Calculate head loss.

Repeat to obtain data for all specified flow rates for all operating hoses.

7.9.3 Measurement of noise level

7.9.3.1 Apparatus

7.9.3.1.1 Precision sound level meter, type I instrument in accordance with IEC 61672-1.

7.9.3.1.2 Non-rigid suspension system, for the cannula.

7.9.3.2 Procedure

Fix the sound-level meter on a tripod. Suspend the cannula perpendicular with their opening at a distance of 0,50 m from the sound-level meter. Operate the suction system at the specified air flow rate of 250 Nl/min for high-volume and 90 Nl/min³⁾ for medium-volume suction systems. Measure the maximum A-weighted sound pressure value generated from the cannula.

7.10 Water sampling connection point

Check the instruction for use and the technical description to ensure that all information for water sampling is provided in the manufacturer's technical description.

7.11 Incoming water and air quality

Check the instructions for use and the technical description to ensure that all relevant requirements are provided.

7.12 Supply connections

Check the instruction for use and the technical description and the dental unit to ensure that all relevant requirements are provided and using readily available measuring devices.

8 Manufacturer's instructions for use

Dental units shall be accompanied by documents containing relevant information as specified in ISO 7494-1, Clause 8. In addition, the following information shall be provided by the manufacturer:

- a) type(s) of suction system regarding air volume flow rate (e.g. type 1: high-volume or type 2: medium-volume) with which the dental unit is intended to be used, if applicable (see [4.2](#));
- b) requirements for the incoming water (see [5.2.1](#));
- c) a statement regarding the existence of applicable regulations, if available, concerning the quality of drinking water (see [5.2.1](#));
- d) a statement regarding the existence of applicable regulations, if available, and which provisions in the dental unit were made (see [5.2.3](#));
- e) if the dental unit is equipped with particle filters and/or bacterial filters for air and/or water, the filter specification, the information on replacement filters, the maintenance procedure(s) and schedule (see [5.2.6](#), [5.2.7](#), [5.3.2](#), and [5.3.3](#));
- f) if a bottled water system is provided, information about decontamination of the reservoir and water lines or replacement of disposable ones, and information about connecting the bottled water system to the dental unit (see [5.2.8](#));
- g) if the dental unit does not prevent the retraction of procedural water into the dental unit, a statement that only instruments which include anti-retraction devices are to be used together with the dental unit (see [5.2.9](#));
- h) if a disinfection system is included in the dental unit, instructions how to use the water disinfection system and how to control the water quality (see [5.2.10](#));
- i) information about the location and operation of the water sampling connection point, if applicable (see [5.2.11](#));
- j) requirements for the incoming air (see [5.3.1](#));

3) Nl/min indicates *normal litres per minute*, the amount of air that flows through a pipe calculated back to "normal" conditions [0 °C and 1 atm or 1,01325 bar (1 bar = 0,1 MPa = 0,1 N/mm² = 10⁵ N/m²)].

- k) if air separators are included in the dental unit, information concerning the technique for maintenance, and replacement of the air separators (see [5.4.3](#));
- l) nominal size of the cannula connector and specifications for cannula that can be used with the connector (see [5.4.4.1](#));
- m) specifications for the suction system solids filter and procedures and schedule for its maintenance and replacement (see [5.4.6](#));
- n) if no water disinfection system is installed into the dental unit, the manufacturer shall give information on how to maintain the water supply system inside the dental unit (e.g. using a biofilm remover or other chemicals).

9 Technical description

Dental units shall be accompanied by documents containing relevant information as specified in ISO 7494-1, Clause 8. In addition, the following information shall be provided by the manufacturer:

- a) information about whether the dental unit suction system is compatible with wet, semi-dry, or dry suction systems (see [4.1](#));
- b) type(s) of suction system regarding air volume flow rate (e.g. type 1: high-volume or type 2: medium-volume) with which the dental unit is intended to be used, if applicable (see [4.2](#));
- c) dimensions and location of connections for supply and waste lines for the dental unit (see [5.1](#));
- d) a statement regarding the existence of applicable regulations, if available, concerning the quality of drinking water (see [5.2.1](#));
- e) requirements for the incoming water (see [5.2.1](#));
- f) a statement regarding the existence of applicable regulations, if available, for backflow prevention (see [5.2.3](#)) and which provisions in the dental unit were made (see [5.2.3](#));
- g) information about particle filters and/or bacterial filters for air and/or water, if applicable (see [5.2.6](#), [5.2.7](#), [5.3.2](#), and [5.3.3](#));
- h) information about the installation of a sampling point for incoming water at or near the incoming water connection point, if applicable (see [5.2.11](#));
- i) information about the location and operation of the sampling point for incoming water for collecting incoming samples for bacterial testing or other testing, if applicable (see [5.2.11](#));
- j) maximum wastewater flow rate from the dental unit that the drain shall be capable of accommodating (see [5.2.12](#));
- k) description of the minimum gradient of the wastewater lines (see [5.2.12](#));
- l) requirements for the incoming air (see [5.3.1](#));
- m) a statement regarding the existence of national or international regulations, if available, concerning the quality of dental air (see [5.3.1](#));
- n) table or graph providing typical pressure head loss of the dental unit suction system from the point of the suction source connection point up to the atmospheric end of the cannula (see [5.4.2](#));
- o) if an air separator is included in the dental unit, information about maintenance and replacement of the air separator (see [5.4.3](#));
- p) specification for the suction system solids filter, including rated mesh size and compatibility with air abrasives, and information about maintenance and replacement of the solids filter (see [5.4.6](#));

- q) minimum and maximum static vacuum pressure at the suction connection point (see [5.4.1](#)) and information about the suction connection dimensions (see [5.4.8](#));
- r) schematic diagram of tubing showing the components and connections in the dental unit, if applicable (see [Figure A.1](#)).

Annex A
(informative)

**Schematic diagram of possible components and connections in
a dental unit**

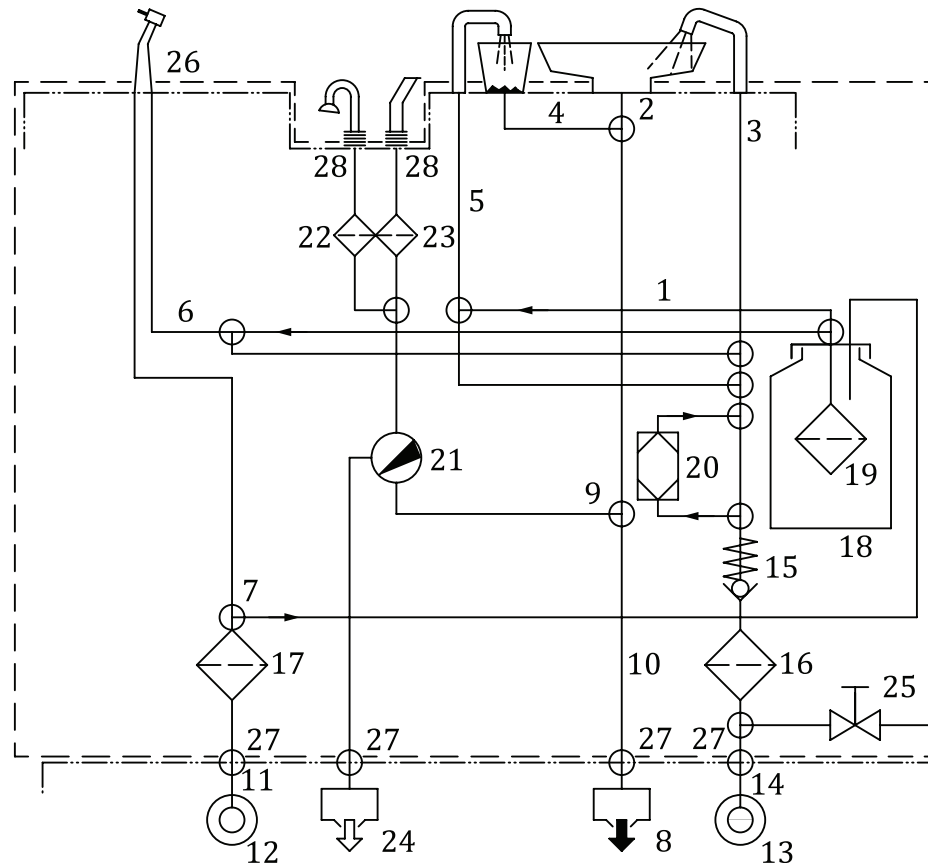

Key

- | | | | |
|----|---|----|--|
| 1 | procedural water or solution supplied by the bottled water system reservoir | 15 | backflow prevention device |
| 2 | wastewater outlet from the cuspidor | 16 | water particle filter |
| 3 | non-procedural water supplied to the cuspidor | 17 | air particle filter |
| 4 | wastewater lines within the dental unit | 18 | bottled water system reservoir |
| 5 | procedural water supplied to the cup filler | 19 | bottled water system particle filter |
| 6 | procedural water supplied to dental instruments | 20 | water disinfection system |
| 7 | air for dental instruments and supplied to bottled water systems | 21 | air separator |
| 8 | wastewater drain | 22 | saliva ejector solids filter |
| 9 | wastewater connection point | 23 | suction handpiece solids filter |
| 10 | wastewater line | 24 | central suction source |
| 11 | incoming air connection point | 25 | incoming water sampling connection point |
| 12 | incoming air | 26 | dental handpiece with water and air supply |
| 13 | incoming water from an external drinking water supply | 27 | connection points |
| 14 | incoming water connection point | 28 | cannula connector |

Figure A.1 — Schematic diagram of possible components and connections in a dental unit

Annex B (informative)

Test sequences

Test report no.	
Products	
Name and address of the applicant/client	
Name and address of the manufacturer	
Name and address of the factory	
Trademark (if any)	
Model/Type ref.	
Rating and principal characteristics	
A sample of the product was tested and found to be in conformity with the International Standard	ISO 7494-2:2015
Additional information (if necessary)	
Information about modifications	
This test report is issued by Testing/Certification Institute	
Name and address:	
Date:	
Test by: (name + signature)	
Approved by: (name + signature)	

ISO 7494-2:2015		TEST REPORT REFERENCE NUMBER:			
CLAUSE NO	REQUIREMENTS/DESCRIPTION	COMPLIANCE/VERDICT			Results, observations, notes, comments
		PASS	FAIL	N/A	
6	Sampling: Is the test device a representative sample of the dental unit?				
4.1	Classification of suction systems: Does the test device include any suction system?				
4.1 a) to c)	If yes, which suction system “dry”, “semi-dry”, or “wet”?				
4.2	Classification of suction air volume flow rate: Does the test device include any suction system?				
4.2 a)	If yes, is it a high-volume suction system, of at least 250 NI/min?				
4.2 b)	If yes, is it a medium-volume suction system, of at least 90 NI/min up to 250 NI/min?				
5.1	Requirements for supply connections: Are the configurations and the dimensions in accordance with the requirements?				
5.2	Requirements for supply connections				
5.2.1	Does the instruction for use and the technical description include the relevant requirements for incoming water?				
5.2.2	Is there an ISO 14971 risk analysis report about the materials used in the water path of dental unit available?				
5.2.3	Does the dental unit include a backflow prevention device in accordance with the requirements?				
5.2.4	Is the air gap distance between rinse water outlet and cuspidor spill over level at least 20 mm?				
5.2.5	If a water venturi device is used, is an additional backflow prevention device available?				
5.2.6	Does the dental unit directly connected to an external drinking water supply or a bottled water system have a particle filter with an effective mesh size not exceeding 100 µm?				
5.2.7	If a bacterial filter is installed in the dental unit, does the mesh size not exceed 0,22 µm?				
5.2.8	Is the installation of a bottled water system equipped with a backflow prevention device or is it separated from the external drinking water supply system?				
5.2.9	Is the retraction of procedural water or solutions in the dental unit ≤ 40 mm ³ ?				
5.2.10	Is the installation of a water disinfection system equipped with a backflow prevention device or is it separated from the external drinking water supply system?				
5.2.11	Does the instruction for use and the technical description give information about the water sampling point?				
5.2.12	Does the technical description include information about the maximum wastewater flow rate?				

5.3.1 a)	Does the instruction for use and the technical description include air pressure limits?				
5.3.1 b)	Does the instruction for use and the technical description include air flow rate limits?				
5.3.1 c)	Does the instruction for use and the technical description include humidity limits?				
5.3.1 d)	Does the instruction for use and the technical description include oil contamination limits?				
5.3.1 e)	Does the instruction for use and the technical description include particulate contamination limits?				
5.3.2	Is a particle filter with an effective mesh size not exceeding 50 µm in the incoming air line installed?				
5.3.3	If a bacterial filter is installed in the dental unit, does the mesh size not exceed 0,22 µm?				
5.4.1	Does the technical description include requirements for the minimum and maximum vacuum pressure?				
5.4.1	Does the dental unit withstand the maximum vacuum pressure without damage?				
5.4.2	Was the head loss measured for all suction instruments between the dental unit suction source connection point and the atmospheric end of the cannula by different flow rates from 90 NI/min up to 400 NI/min, under normal conditions? Are the results reported in the Technical Description?				
5.4.3	Is the air separator easy to maintain and is the technique for maintenance described in the instructions for use?				
5.4.4.1	Does the manufacturer of the cannula connector specify the requirements for cannula?				
5.4.4.2	Do all cannula connectors allow access to every point of the patient's mouth without distortion of the hoses?				
5.4.4.3	Is the handling of the cannula connectors together with the cannula in accordance with IEC 62366?				
5.4.4.4	Does the manufacturer use the connections of the cannulas and cannula connectors systems in accordance with the recommendations?				
5.4.5	Is the performance of the operating hoses in accordance with the requirements?				
5.4.6	Are the requirements for solids filter fulfilled?				
5.4.7	Does the generated noise not exceed 65 dB (A)?				
5.4.8	Does the technical description describe the dimensions of the suction connection point?				
8	Does the manufacturer provide the instructions for use?				
8 a)	Is the type of suction system (high-volume or medium-volume) provided? See 4.2.				
8 b)	Is a description of the required quality of the incoming water for the dental unit provided? See 5.2.1.				
8 c)	Is a statement regarding the existence or applicable regulations, if available, concerning the quality of drinking water provided? See 5.2.1.				
8 d)	Is a statement regarding the existence of applicable regulations, if available, and which provisions in the dental unit were made provided? See 5.2.3.				

8 e)	Is the filter specification for air, water, particle, and bacterial filters together with the information about replacement and maintenance procedure provided? See 5.2.6 , 5.2.7 , 5.3.2 , and 5.3.3 .				
8 f)	If a bottled water system is provided, is the information about decontamination of the reservoir and water lines or replacement of disposable ones, and information about connecting the bottled water system to the dental unit provided? See 5.2.8 .				
8 g)	If the dental unit does not prevent the retraction of procedural water into the dental unit, is a statement that only instruments which include anti-retraction devices shall be used together with the dental unit provided? See 5.2.9 .				
8 h)	If a disinfection system is included in the dental unit, is the information on how to use the system and how to control the water quality provided? See 5.2.10 .				
8 i)	Is a description that the dental unit is installed and placed in such a way that additional water sampling connection point can be used provided? See 5.2.11 .				
8 j)	Is a specification of the required quality of the incoming air provided? See 5.3.1 .				
8 k)	If air separators are included in the dental unit, is the information concerning the technique for maintenance and replacement of the air separators provided? See 5.4.3 .				
8 l)	Is the specification for the cannula connector and the cannula provided? See 5.4.4.1 .				
8 m)	Is the specification for the dental unit suction system solids filter and the procedures for its maintenance and replacement provided? See 5.4.6 .				
8 n)	If no water disinfection system is installed into the dental unit, is there information on how to maintain the water supply system into the dental unit?				
9	Does the manufacturer provide a technical description?				
9 a)	Is the class of suction system (dry-system, semi-dry-system, or wet system) provided? See 4.1 .				
9 b)	Is the type of suction system (high-volume or medium-volume) provided? See 4.2 .				
9 c)	Are the dimensions and location of all connections provided? See 5.1 .				
9 d)	Is the statement regarding the existence of applicable regulations, if available, concerning the quality of drinking water provided? See 5.2.1 .				
9 e)	Are the requirements for incoming water described? See 5.2.1 .				
9 f)	Is the statement regarding the existence of applicable regulations, if available, for backflow prevention provided? See 5.2.3 .				
9 g)	Are the filter specifications for air, water, particle, and bacterial filters together with the information about replacement and maintenance procedure provided? See 5.2.6 , 5.2.7 , 5.3.2 , and 5.3.3 .				
9 h)	Is the information about the installation of water sampling connection point provided? See 5.2.11 .				

9 i)	Is the information about the location and operation of the water sampling connection point for collecting water samples for testing provided? See 5.2.11 .				
9 j)	Is the information about the maximum wastewater flow rate for the drain provided? See 5.2.12 .				
9 k)	Is the information about the minimum gradient of wastewater lines provided? See 5.2.12 .				
9 l)	Are the requirements for incoming air described? See 5.3.1 .				
9 m)	Is the information about the existence national or international regulations about the quality of dental air provided? See 5.3.1 .				
9 n)	Is the information (table or graph) about the pressure head loss provided? See 5.4.2 .				
9 o)	If air separators are included in the dental unit, is the information concerning the technique for maintenance and replacement of the air separators provided? See 5.4.3 .				
9 p)	Is the specification for the dental unit suction system solids filter and the procedures for maintenance and replacement provided? See 5.4.6 .				
9 q)	Is the information for minimum and maximum static vacuum pressure at the suction connection point and connection dimensions provided? See 5.4.1 and 5.4.8 .				
9 r)	Is a schematic diagram of tubing, components and connections provided?				

END OF THE REPORT, CONTINUED WITH OR WITHOUT ATTACHMENT?

Bibliography

- [1] ISO/TS 11080, *Dentistry — Essential characteristics of test methods for the evaluation of treatment methods intended to improve or maintain the microbiological quality of dental unit procedural water*
- [2] ISO 11143, *Dentistry — Amalgam separators*
- [3] EN 1717, *Protection against pollution of potable water in water installations and general requirements of devices to prevent pollution by backflow*

British Standards Institution (BSI)

BSI is the national body responsible for preparing British Standards and other standards-related publications, information and services.

BSI is incorporated by Royal Charter. British Standards and other standardization products are published by BSI Standards Limited.

About us

We bring together business, industry, government, consumers, innovators and others to shape their combined experience and expertise into standards-based solutions.

The knowledge embodied in our standards has been carefully assembled in a dependable format and refined through our open consultation process. Organizations of all sizes and across all sectors choose standards to help them achieve their goals.

Information on standards

We can provide you with the knowledge that your organization needs to succeed. Find out more about British Standards by visiting our website at bsigroup.com/standards or contacting our Customer Services team or Knowledge Centre.

Buying standards

You can buy and download PDF versions of BSI publications, including British and adopted European and international standards, through our website at bsigroup.com/shop, where hard copies can also be purchased.

If you need international and foreign standards from other Standards Development Organizations, hard copies can be ordered from our Customer Services team.

Subscriptions

Our range of subscription services are designed to make using standards easier for you. For further information on our subscription products go to bsigroup.com/subscriptions.

With **British Standards Online (BSOL)** you'll have instant access to over 55,000 British and adopted European and international standards from your desktop. It's available 24/7 and is refreshed daily so you'll always be up to date.

You can keep in touch with standards developments and receive substantial discounts on the purchase price of standards, both in single copy and subscription format, by becoming a **BSI Subscribing Member**.

PLUS is an updating service exclusive to BSI Subscribing Members. You will automatically receive the latest hard copy of your standards when they're revised or replaced.

To find out more about becoming a BSI Subscribing Member and the benefits of membership, please visit bsigroup.com/shop.

With a **Multi-User Network Licence (MUNL)** you are able to host standards publications on your intranet. Licences can cover as few or as many users as you wish. With updates supplied as soon as they're available, you can be sure your documentation is current. For further information, email bsmusales@bsigroup.com.

BSI Group Headquarters

389 Chiswick High Road London W4 4AL UK

Revisions

Our British Standards and other publications are updated by amendment or revision.

We continually improve the quality of our products and services to benefit your business. If you find an inaccuracy or ambiguity within a British Standard or other BSI publication please inform the Knowledge Centre.

Copyright

All the data, software and documentation set out in all British Standards and other BSI publications are the property of and copyrighted by BSI, or some person or entity that owns copyright in the information used (such as the international standardization bodies) and has formally licensed such information to BSI for commercial publication and use. Except as permitted under the Copyright, Designs and Patents Act 1988 no extract may be reproduced, stored in a retrieval system or transmitted in any form or by any means – electronic, photocopying, recording or otherwise – without prior written permission from BSI. Details and advice can be obtained from the Copyright & Licensing Department.

Useful Contacts:

Customer Services

Tel: +44 845 086 9001

Email (orders): orders@bsigroup.com

Email (enquiries): cservices@bsigroup.com

Subscriptions

Tel: +44 845 086 9001

Email: subscriptions@bsigroup.com

Knowledge Centre

Tel: +44 20 8996 7004

Email: knowledgecentre@bsigroup.com

Copyright & Licensing

Tel: +44 20 8996 7070

Email: copyright@bsigroup.com



...making excellence a habit.™