

Building construction — Jointing products — Determination of resistance to flow of sealants

The European Standard EN ISO 7390:2003 has the status of a
British Standard

ICS 91.100.50

National foreword

This British Standard is the official English language version of EN ISO 7390:2003. It is identical with ISO 7390:2002. It supersedes BS EN 27390:1991 (1998) which is withdrawn.

The UK participation in its preparation was entrusted to Technical Committee B/547, Sealants for building and construction, which has the responsibility to:

- aid enquirers to understand the text;
- present to the responsible international/European committee any enquiries on the interpretation, or proposals for change, and keep the UK interests informed;
- monitor related international and European developments and promulgate them in the UK.

A list of organizations represented on this committee can be obtained on request to its secretary.

Cross-references

The British Standards which implement international or European publications referred to in this document may be found in the *BSI Catalogue* under the section entitled “International Standards Correspondence Index”, or by using the “Search” facility of the *BSI Electronic Catalogue* or of British Standards Online.

This publication does not purport to include all the necessary provisions of a contract. Users are responsible for its correct application.

Compliance with a British Standard does not of itself confer immunity from legal obligations.

Summary of pages

This document comprises a front cover, an inside front cover, the EN ISO title page, the EN ISO foreword page, the ISO title page, pages ii and iii, a blank page, pages 1 to 4, the Annex ZA page and a back cover.

The BSI copyright notice displayed in this document indicates when the document was last issued.

Amendments issued since publication

Amd. No.	Date	Comments

This British Standard was published under the authority of the Standards Policy and Strategy Committee on 22 January 2004

© BSI 22 January 2004

ISBN 0 580 43312 9

English version

Building construction - Jointing products - Determination of
resistance to flow of sealants (ISO 7390:2003)

Construction immobilière - Produits pour joints -
Détermination de la résistance au coulage des mastics
(ISO 7390:2003)

Hochbau - Fugendichtstoffe - Bestimmung des
Standvermögens (ISO 7390:2002)

This European Standard was approved by CEN on 25 September 2003.

CEN members are bound to comply with the CEN/CENELEC Internal Regulations which stipulate the conditions for giving this European Standard the status of a national standard without any alteration. Up-to-date lists and bibliographical references concerning such national standards may be obtained on application to the Management Centre or to any CEN member.

This European Standard exists in three official versions (English, French, German). A version in any other language made by translation under the responsibility of a CEN member into its own language and notified to the Management Centre has the same status as the official versions.

CEN members are the national standards bodies of Austria, Belgium, Czech Republic, Denmark, Finland, France, Germany, Greece, Hungary, Iceland, Ireland, Italy, Luxembourg, Malta, Netherlands, Norway, Portugal, Slovakia, Spain, Sweden, Switzerland and United Kingdom.



EUROPEAN COMMITTEE FOR STANDARDIZATION
COMITÉ EUROPÉEN DE NORMALISATION
EUROPÄISCHES KOMITEE FÜR NORMUNG

Management Centre: rue de Stassart, 36 B-1050 Brussels

Foreword

The text of ISO 7390:2002 has been prepared by Technical Committee ISO/TC 59 "Building construction" of the International Organization for Standardization (ISO) and has been taken over as EN ISO 7390:2003 by CMC.

This European Standard shall be given the status of a national standard, either by publication of an identical text or by endorsement, at the latest by May 2004, and conflicting national standards shall be withdrawn at the latest by May 2004.

This document supersedes EN 27390:1990.

According to the CEN/CENELEC Internal Regulations, the national standards organizations of the following countries are bound to implement this European Standard: Austria, Belgium, Czech Republic, Denmark, Finland, France, Germany, Greece, Hungary, Iceland, Ireland, Italy, Luxembourg, Malta, Netherlands, Norway, Portugal, Slovakia, Spain, Sweden, Switzerland and the United Kingdom.

Endorsement notice

The text of ISO 7390:2002 has been approved by CEN as EN ISO 7390:2003 without any modifications.

NOTE Normative references to International Standards are listed in Annex ZA (normative).

INTERNATIONAL STANDARD

ISO 7390

Third edition
2002-10-01

Building construction — Jointing products — Determination of resistance to flow of sealants

*Construction immobilière — Produits pour joints — Détermination de la
résistance au coulage des mastics*



Reference number
ISO 7390:2002(E)

Foreword

ISO (the International Organization for Standardization) is a worldwide federation of national standards bodies (ISO member bodies). The work of preparing International Standards is normally carried out through ISO technical committees. Each member body interested in a subject for which a technical committee has been established has the right to be represented on that committee. International organizations, governmental and non-governmental, in liaison with ISO, also take part in the work. ISO collaborates closely with the International Electrotechnical Commission (IEC) on all matters of electrotechnical standardization.

International Standards are drafted in accordance with the rules given in the ISO/IEC Directives, Part 3.

Draft International Standards adopted by the technical committees are circulated to the member bodies for voting. Publication as an International Standard requires approval by at least 75 % of the member bodies casting a vote.

Attention is drawn to the possibility that some of the elements of this International Standard may be the subject of patent rights. ISO shall not be held responsible for identifying any or all such patent rights.

International Standard ISO 7390 was prepared by Technical Committee ISO/TC 59, *Building construction*, Subcommittee SC 8, *Jointing products*.

This third edition cancels and replaces the second edition (ISO 7390:1987), which has been technically revised.

Building construction — Jointing products — Determination of resistance to flow of sealants

1 Scope

This International Standard specifies a method for the determination of the resistance to flow of sealants, by loss of cohesion under their own weight. These sealants are used in joints in vertical surfaces in building construction.

2 Normative reference

The following normative document contains provisions which, through reference in this text, constitute provisions of this International Standard. For dated references, subsequent amendments to, or revisions of, this publication do not apply. However, parties to agreements based on this International Standard are encouraged to investigate the possibility of applying the most recent edition of the normative document indicated below. For undated references, the latest edition of the normative document referred to applies. Members of ISO and IEC maintain registers of currently valid International Standards.

ISO 6927, *Building construction — Jointing products — Sealants — Vocabulary*

3 Terms and definitions

For the purposes of this International Standard, the terms and definitions for sealants specified in ISO 6927 apply.

4 Principle

The sealant, applied in a U-profile, is exposed for a defined time to various defined temperatures. The open surface of the sealant is in a vertical position during the test. The flow of the sealant out of the U-profile is measured at the end of the test period.

5 Apparatus

5.1 Non-porous and smooth U-profiles, for example anodized or non-anodized aluminium, with a length of $(150 \pm 1,0)$ mm, with both ends open and optionally the back surface extended at one end (see Figures 1 and 2), having a cross section with the following internal dimensions:

- width: $(20 \pm 0,2)$ mm;
- depth: $(10 \pm 0,2)$ mm.

Other dimensions may be applied, for example width $(10 \pm 0,2)$ mm and depth $(10 \pm 0,2)$ mm.

5.2 Strips of polyethylene (PE) sheet, with the following dimensions:

- thickness $\leq 0,5$ mm;
- width to cover the inner backside of the U-profile.

Under test conditions, the length of the PE-strip shall not change by more than 1 mm.

5.3 Ventilated convection-type oven, capable of operating at (70 ± 2) °C.

5.4 Ventilated convection-type oven, capable of operating at (50 ± 2) °C.

5.5 Refrigerated container, capable of operating at (5 ± 2) °C.

5.6 Measuring device, scaled in 0,5 mm.

6 Test method

6.1 Preparation of test specimens

The appropriate number of U-profiles used is determined according to 6.2. The U-profiles shall be first cleaned and dried.

Place a strip of PE-sheet (5.2) along the backside base of each U-profile, overlapping at the top and fixed at the outer reverse side, for example with adhesive tape. The PE-strip shall exactly cover the inside base of the U-profile.

NOTE If the PE-strip is too narrow, the sealant will adhere to the backside base of the U-profile. If the PE-strip is too wide, it will curl inwards decreasing the contact area between the sealant and the sides of the U-profile.

Bring the U-profile and the sealant to (23 ± 2) °C. Fill the U-profile with sealant. The following precautions shall be taken:

- a) the formation of air bubbles shall be avoided;
- b) the sealant shall be pressed on the inner profile surfaces;
- c) the sealant surface shall be trimmed so that it is flush with the face and ends of the U-profile;
- d) the polyethylene strip shall be loosened from the reverse side of the U-profile.

6.2 Procedures

6.2.1 General

For each test temperature of 70 °C and/or 50 °C and/or 5 °C, and for each procedure A and B, one test specimen shall be used.

The test specimens shall be tested either according to procedure A (see 6.2.2) or procedure B (see 6.2.3), as agreed.

In the case of the sealant sliding from the U-profile, the inner surface of the U-profile shall be treated in accordance with the sealant manufacturer's recommendations. The test shall be repeated.

6.2.2 Procedure A

Immediately after the preparation (6.1), place the test specimen in the oven (5.3 or 5.4) or in the refrigerated container (5.5) in a vertical position with the possible extension of the U-profile at the bottom (see Figure 1).

Submit each test specimen to each defined test temperature for 24 h and then remove it from the oven or refrigerated container.

Measure in a vertical direction, using the measuring device (5.6), the distance that the bottom edge of the sealant of each test specimen has moved downwards.

Dimensions in millimetres

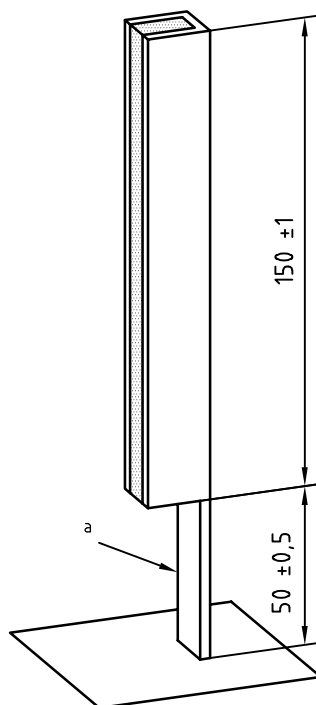

^a Optional

Figure 1 — Position of test specimen for procedure A

6.2.3 Procedure B

Immediately after the preparation (6.1), place the test specimen in the oven (5.3 or 5.4) or in the refrigerated container (5.5), in a horizontal position with the open sealant surface in a vertical plane (see Figure 2).

Dimensions in millimetres

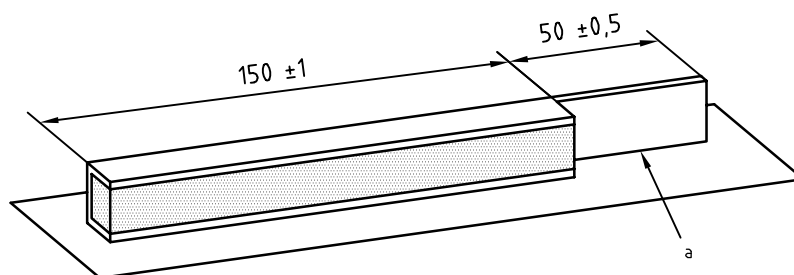

^a Optional

Figure 2 — Position of test specimen for procedure B

Submit each test specimen to each defined test temperature for 24 h and then remove it from the oven or refrigerated container.

Measure in a horizontal direction, using the measuring device (5.6), the distance that the sealant has projected beyond the front of the U-profile of each test specimen.

7 Test report

The test report shall contain the following information:

- a) name of laboratory and date of test;
- b) a reference to this International Standard;
- c) name, type (chemical family) and colour of sealant;
- d) batch of sealant from which the test specimens were produced;
- e) type of profile used (anodized or non-anodized aluminium or other material);
- f) internal dimensions of U-profiles if different from those in 5.1;
- g) applied procedure according to 6.2;
- h) name and batch of the surface treatment, if any;
- i) flow of the sealant of each test specimen, in millimetres rounded to the nearest 1 mm, stating the test temperature used;
- j) any deviations from the method of this International Standard.

Annex ZA (normative)

Normative references to international publications with their relevant European publications

This European Standard incorporates by dated or undated reference, provisions from other publications. These normative references are cited at the appropriate places in the text and the publications are listed hereafter. For dated references, subsequent amendments to or revisions of any of these publications apply to this European Standard only when incorporated in it by amendment or revision. For undated references the latest edition of the publication referred to applies (including amendments).

NOTE Where an International Publication has been modified by common modifications, indicated by (mod.), the relevant EN/HD applies.

<u>Publication</u>	<u>Year</u>	<u>Title</u>	<u>EN</u>	<u>Year</u>
ISO 6927	1981	Building construction - Jointing products - Sealants – Vocabulary	EN ISO 26927	1990

BSI — British Standards Institution

BSI is the independent national body responsible for preparing British Standards. It presents the UK view on standards in Europe and at the international level. It is incorporated by Royal Charter.

Revisions

British Standards are updated by amendment or revision. Users of British Standards should make sure that they possess the latest amendments or editions.

It is the constant aim of BSI to improve the quality of our products and services. We would be grateful if anyone finding an inaccuracy or ambiguity while using this British Standard would inform the Secretary of the technical committee responsible, the identity of which can be found on the inside front cover.
Tel: +44 (0)20 8996 9000. Fax: +44 (0)20 8996 7400.

BSI offers members an individual updating service called PLUS which ensures that subscribers automatically receive the latest editions of standards.

Buying standards

Orders for all BSI, international and foreign standards publications should be addressed to Customer Services. Tel: +44 (0)20 8996 9001.
Fax: +44 (0)20 8996 7001. Email: orders@bsi-global.com. Standards are also available from the BSI website at <http://www.bsi-global.com>.

In response to orders for international standards, it is BSI policy to supply the BSI implementation of those that have been published as British Standards, unless otherwise requested.

Information on standards

BSI provides a wide range of information on national, European and international standards through its Library and its Technical Help to Exporters Service. Various BSI electronic information services are also available which give details on all its products and services. Contact the Information Centre.
Tel: +44 (0)20 8996 7111. Fax: +44 (0)20 8996 7048. Email: info@bsi-global.com.

Subscribing members of BSI are kept up to date with standards developments and receive substantial discounts on the purchase price of standards. For details of these and other benefits contact Membership Administration.
Tel: +44 (0)20 8996 7002. Fax: +44 (0)20 8996 7001.
Email: membership@bsi-global.com.

Information regarding online access to British Standards via British Standards Online can be found at <http://www.bsi-global.com/bsonline>.

Further information about BSI is available on the BSI website at <http://www.bsi-global.com>.

Copyright

Copyright subsists in all BSI publications. BSI also holds the copyright, in the UK, of the publications of the international standardization bodies. Except as permitted under the Copyright, Designs and Patents Act 1988 no extract may be reproduced, stored in a retrieval system or transmitted in any form or by any means – electronic, photocopying, recording or otherwise – without prior written permission from BSI.

This does not preclude the free use, in the course of implementing the standard, of necessary details such as symbols, and size, type or grade designations. If these details are to be used for any other purpose than implementation then the prior written permission of BSI must be obtained.

Details and advice can be obtained from the Copyright & Licensing Manager.
Tel: +44 (0)20 8996 7070. Fax: +44 (0)20 8996 7553.
Email: copyright@bsi-global.com.