

BS EN ISO 7047:2011



BSI Standards Publication

**Raised countersunk head
screws (common head style)
with type H or type Z cross
recess — Product grade A (ISO
7047:2011)**

bsi.

...making excellence a habit.™

National foreword

This British Standard is the UK implementation of EN ISO 7047:2011. It supersedes BS EN ISO 7047:1995 which is withdrawn.

The UK participation in its preparation was entrusted to Technical Committee FME/9/3, Fasteners - Product Standards.

A list of organizations represented on this committee can be obtained on request to its secretary.

This publication does not purport to include all the necessary provisions of a contract. Users are responsible for its correct application.

© BSI 2011

ISBN 978 0 580 72978 2

ICS 21.060.10

Compliance with a British Standard cannot confer immunity from legal obligations.

This British Standard was published under the authority of the Standards Policy and Strategy Committee on 30 September 2011.

Amendments issued since publication

Date	Text affected
------	---------------

EUROPEAN STANDARD

EN ISO 7047

NORME EUROPÉENNE

EUROPÄISCHE NORM

September 2011

ICS 21.060.10

Supersedes EN ISO 7047:1994

English Version

Raised countersunk head screws (common head style) with type H or type Z cross recess - Product grade A (ISO 7047:2011)

Vis à métaux à tête fraisée bombée à empreinte cruciforme de type H ou de type Z - Grade A (ISO 7047:2011)

Linsensenkschrauben (Einheitskopf) mit Kreuzschlitz Form H oder Form Z - Produktklasse A (ISO 7047:2011)

This European Standard was approved by CEN on 8 August 2011.

CEN members are bound to comply with the CEN/CENELEC Internal Regulations which stipulate the conditions for giving this European Standard the status of a national standard without any alteration. Up-to-date lists and bibliographical references concerning such national standards may be obtained on application to the CEN-CENELEC Management Centre or to any CEN member.

This European Standard exists in three official versions (English, French, German). A version in any other language made by translation under the responsibility of a CEN member into its own language and notified to the CEN-CENELEC Management Centre has the same status as the official versions.

CEN members are the national standards bodies of Austria, Belgium, Bulgaria, Croatia, Cyprus, Czech Republic, Denmark, Estonia, Finland, France, Germany, Greece, Hungary, Iceland, Ireland, Italy, Latvia, Lithuania, Luxembourg, Malta, Netherlands, Norway, Poland, Portugal, Romania, Slovakia, Slovenia, Spain, Sweden, Switzerland and United Kingdom.



EUROPEAN COMMITTEE FOR STANDARDIZATION
COMITÉ EUROPÉEN DE NORMALISATION
EUROPÄISCHES KOMITEE FÜR NORMUNG

Management Centre: Avenue Marnix 17, B-1000 Brussels

Foreword

This document (EN ISO 7047:2011) has been prepared by Technical Committee ISO/TC 2 "Fasteners" in collaboration with Technical Committee CEN/TC 185 "Fasteners" the secretariat of which is held by DIN.

This European Standard shall be given the status of a national standard, either by publication of an identical text or by endorsement, at the latest by March 2012, and conflicting national standards shall be withdrawn at the latest by March 2012.

Attention is drawn to the possibility that some of the elements of this document may be the subject of patent rights. CEN [and/or CENELEC] shall not be held responsible for identifying any or all such patent rights.

This document supersedes EN ISO 7047:1994.

According to the CEN/CENELEC Internal Regulations, the national standards organizations of the following countries are bound to implement this European Standard: Austria, Belgium, Bulgaria, Croatia, Cyprus, Czech Republic, Denmark, Estonia, Finland, France, Germany, Greece, Hungary, Iceland, Ireland, Italy, Latvia, Lithuania, Luxembourg, Malta, Netherlands, Norway, Poland, Portugal, Romania, Slovakia, Slovenia, Spain, Sweden, Switzerland and the United Kingdom.

Endorsement notice

The text of ISO 7047:2011 has been approved by CEN as a EN ISO 7047:2011 without any modification.

Foreword

ISO (the International Organization for Standardization) is a worldwide federation of national standards bodies (ISO member bodies). The work of preparing International Standards is normally carried out through ISO technical committees. Each member body interested in a subject for which a technical committee has been established has the right to be represented on that committee. International organizations, governmental and non-governmental, in liaison with ISO, also take part in the work. ISO collaborates closely with the International Electrotechnical Commission (IEC) on all matters of electrotechnical standardization.

International Standards are drafted in accordance with the rules given in the ISO/IEC Directives, Part 2.

The main task of technical committees is to prepare International Standards. Draft International Standards adopted by the technical committees are circulated to the member bodies for voting. Publication as an International Standard requires approval by at least 75 % of the member bodies casting a vote.

Attention is drawn to the possibility that some of the elements of this document may be the subject of patent rights. ISO shall not be held responsible for identifying any or all such patent rights.

ISO 7047 was prepared by Technical Committee ISO/TC 2, *Fasteners*, Subcommittee SC 11, *Fasteners with metric external thread*.

This third edition cancels and replaces the second edition (ISO 7047:1994), of which it constitutes a minor revision.

Raised countersunk head screws (common head style) with type H or type Z cross recess — Product grade A

1 Scope

This International Standard specifies the characteristics of countersunk raised head screws of product grade A, with threads from M1,6 to M10 inclusive and with type H or type Z cross recess.

If, in special cases, specifications other than those listed in this International Standard are required, they can be selected from existing International Standards, for example ISO 261, ISO 888, ISO 898-1, ISO 965-2 and ISO 3506-1.

2 Normative references

The following referenced documents are indispensable for the application of this document. For dated references, only the edition cited applies. For undated references, the latest edition of the referenced document (including any amendments) applies.

ISO 225, *Fasteners — Bolts, screws, studs and nuts — Symbols and descriptions of dimensions*

ISO 261, *ISO general purpose metric screw threads — General plan*

ISO 898-1, *Mechanical properties of fasteners made of carbon steel and alloy steel — Part 1: Bolts, screws and studs with specified property classes — Coarse thread and fine pitch thread*

ISO 965-2, *ISO general purpose metric screw threads — Tolerances — Part 2: Limits of sizes for general purpose external and internal screw threads — Medium quality*

ISO 3269, *Fasteners — Acceptance inspection*

ISO 3506-1, *Mechanical properties of corrosion-resistant stainless steel fasteners — Part 1: Bolts, screws and studs*

ISO 4042, *Fasteners — Electroplated coatings*

ISO 4757, *Cross recesses for screws*

ISO 4759-1, *Tolerances for fasteners — Part 1: Bolts, screws, studs and nuts — Product grades A, B and C*

ISO 6157-1, *Fasteners — Surface discontinuities — Part 1: Bolts, screws and studs for general requirements*

ISO 8839, *Mechanical properties of fasteners — Bolts, screws, studs and nuts made of non-ferrous metals*

ISO 8992, *Fasteners — General requirements for bolts, screws, studs and nuts*

ISO 10683, *Fasteners — Non-electrolytically applied zinc flake coatings*

ISO 16048, *Passivation of corrosion-resistant stainless-steel fasteners*

3 Dimensions

See Figure 1 and Table 1. Symbols and descriptions of dimensions are specified in ISO 225.

The shank diameter is approximately equal to the pitch diameter or equal to the permissible major thread diameter.

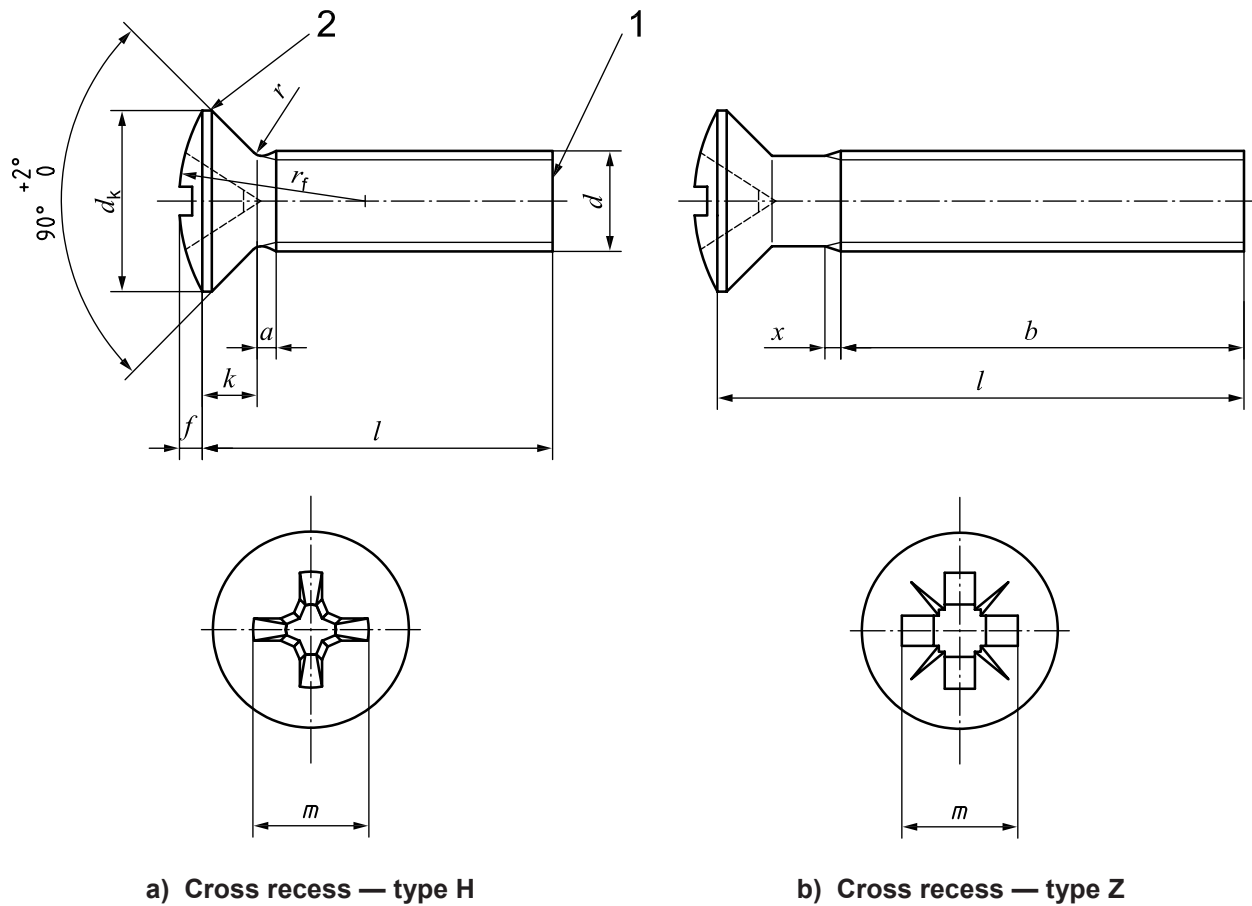

Key

- 1 as-rolled end
- 2 edge (rounded or flat)

Figure 1

Table 1 — Dimensions

Dimensions in millimetres

Thread, d			M1,6	M2	M2,5	M3	(M3,5) ^a	M4	M5	M6	M8	M10	
p^b			0,35	0,4	0,45	0,5	0,6	0,7	0,8	1	1,25	1,5	
a	max.		0,7	0,8	0,9	1	1,2	1,4	1,6	2	2,5	3	
b	min.		25	25	25	25	38	38	38	38	38	38	
d_k^c	Theoretical	max.	3,6	4,4	5,5	6,3	8,2	9,4	10,4	12,6	17,3	20	
	Actual	nom. = max.	3,0	3,8	4,7	5,5	7,30	8,40	9,30	11,30	15,80	18,30	
		min.	2,7	3,5	4,4	5,2	6,94	8,04	8,94	10,87	15,37	17,78	
f	≈		0,4	0,5	0,6	0,7	0,8	1	1,2	1,4	2	2,3	
k^c	nom. = max.		1	1,2	1,5	1,65	2,35	2,7	2,7	3,3	4,65	5	
r	max.		0,4	0,5	0,6	0,8	0,9	1	1,3	1,5	2	2,5	
r_f	≈		3	4	5	6	8,5	9,5	9,5	12	16,5	19,5	
x	max.		0,9	1	1,1	1,25	1,5	1,75	2	2,5	3,2	3,8	
Cross recess	Recess	no.	0			1		2			3	4	
		m	ref.	1,9	2	3	3,4	4,8	5,2	5,4	7,3	9,6	10,4
	Type H	Penetration	max.	1,2	1,5	1,85	2,2	2,75	3,2	3,4	4,0	5,25	6,0
			min.	0,9	1,2	1,50	1,8	2,25	2,7	2,9	3,5	4,75	5,5
	Type Z	Penetration	m ref.	1,9	2,2	2,8	3,1	4,6	5	5,3	7,1	9,5	10,3
			max.	1,20	1,40	1,75	2,08	2,70	3,10	3,35	3,85	5,20	6,05
			min.	0,95	1,15	1,50	1,83	2,25	2,65	2,90	3,40	4,75	5,60
	l_{ad}			Approximate mass, in kilograms per 1 000 pieces ($\rho = 7,85 \text{ kg/dm}^3$) (for information only)									
nom.	min.	max.											
3	2,8	3,2	0,067	0,119	0,212								
4	3,76	4,24	0,078	0,138	0,242	0,351							
5	4,76	5,24	0,09	0,156	0,272	0,395	0,669	0,99					
6	5,76	6,24	0,102	0,175	0,302	0,439	0,729	1,07	1,49				
8	7,71	8,29	0,125	0,212	0,362	0,527	0,849	1,23	1,73	2,79			
10	9,71	10,29	0,145	0,249	0,422	0,615	0,969	1,39	1,97	3,14	6,89		
12	11,65	12,35	0,165	0,287	0,482	0,703	1,09	1,54	2,21	3,49	7,53	11,4	
(14)	13,65	14,35	0,185	0,325	0,543	0,791	1,21	1,7	2,45	3,84	8,17	12,5	
16	15,65	16,35	0,205	0,362	0,603	0,879	1,33	1,85	2,69	4,19	8,81	13,5	
20	19,58	20,42		0,436	0,723	1,06	1,57	2,17	3,17	4,89	10,1	15,5	
25	24,58	25,42			0,874	1,28	1,87	2,56	3,77	5,77	11,7	18	
30	29,58	30,42				1,5	2,17	2,95	4,37	6,64	13,3	20,6	
35	34,5	35,5					2,47	3,34	4,97	7,52	14,9	23,1	
40	39,5	40,5						3,73	5,57	8,39	16,5	25,6	
45	44,5	45,5							6,16	9,27	18,1	28,1	
50	49,5	50,5							6,76	10,1	19,7	30,7	

Table 1 (continued)

Dimensions in millimetres

Thread, d			M1,6	M2	M2,5	M3	(M3,5) ^a	M4	M5	M6	M8	M10
l^{ad}			Approximate mass, in kilograms per 1 000 pieces ($\rho = 7,85 \text{ kg/dm}^3$) (for information only)									
nom.	min.	max.										
(55)	54,05	55,95								11	21,3	33,2
60	59,05	60,95								11,9	22,9	35,7
NOTE Preferred lengths are those between the solid, bold, stepped lines.												
^a Sizes in parentheses should be avoided if possible. ^b P is the pitch of the thread. ^c See ISO 7721. ^d Screws with nominal lengths above the bold, discontinuous line are threaded up to the head; $b = l - (k + a)$.												

4 Specifications and reference International Standards

See Table 2.

Table 2 — Specifications and reference International Standards

Material		Steel	Stainless steel	Non-ferrous metal
General requirements	International Standard	ISO 8992		
Thread	Tolerance class	6g		
	International Standard	ISO 261, ISO 965-2		
Mechanical property	Property class	4.8	A2-50, A2-70	—
	International Standard	ISO 898-1	ISO 3506-1	ISO 8839
Tolerance	Product grade	A		
	International Standard	ISO 4759-1		
Cross recess	International Standard	ISO 4757		
Finish — Coating		As processed		
		Requirements for electroplating are specified in ISO 4042.	Requirements for passivation are specified in ISO 16048.	Requirements for electroplating are specified in ISO 4042.
		Requirements for non-electrolytically applied zinc flake coatings are specified in ISO 10683.		
		Additional requirements or other finishes or coatings shall be agreed between the supplier and the purchaser.		
Surface integrity		Limits for surface discontinuities are specified in ISO 6157-1.		
Acceptability		Acceptance inspection is specified in ISO 3269.		

5 Designation

EXAMPLE A cross-recessed countersunk raised head screw with thread M5, nominal length $l = 20$ mm, property class 4.8 and cross recess type Z is designated as follows:

Countersunk raised head screw ISO 7047 - M5 × 20 - 4.8 - Z

Bibliography

- [1] ISO 888, *Bolts, screws and studs — Nominal lengths, and thread lengths for general purpose bolts*
- [2] ISO 7721, *Countersunk head screws — Head configuration and gauging*

British Standards Institution (BSI)

BSI is the national body responsible for preparing British Standards and other standards-related publications, information and services.

BSI is incorporated by Royal Charter. British Standards and other standardization products are published by BSI Standards Limited.

About us

We bring together business, industry, government, consumers, innovators and others to shape their combined experience and expertise into standards-based solutions.

The knowledge embodied in our standards has been carefully assembled in a dependable format and refined through our open consultation process. Organizations of all sizes and across all sectors choose standards to help them achieve their goals.

Information on standards

We can provide you with the knowledge that your organization needs to succeed. Find out more about British Standards by visiting our website at bsigroup.com/standards or contacting our Customer Services team or Knowledge Centre.

Buying standards

You can buy and download PDF versions of BSI publications, including British and adopted European and international standards, through our website at bsigroup.com/shop, where hard copies can also be purchased.

If you need international and foreign standards from other Standards Development Organizations, hard copies can be ordered from our Customer Services team.

Subscriptions

Our range of subscription services are designed to make using standards easier for you. For further information on our subscription products go to bsigroup.com/subscriptions.

With **British Standards Online (BSOL)** you'll have instant access to over 55,000 British and adopted European and international standards from your desktop. It's available 24/7 and is refreshed daily so you'll always be up to date.

You can keep in touch with standards developments and receive substantial discounts on the purchase price of standards, both in single copy and subscription format, by becoming a **BSI Subscribing Member**.

PLUS is an updating service exclusive to BSI Subscribing Members. You will automatically receive the latest hard copy of your standards when they're revised or replaced.

To find out more about becoming a BSI Subscribing Member and the benefits of membership, please visit bsigroup.com/shop.

With a **Multi-User Network Licence (MUNL)** you are able to host standards publications on your intranet. Licences can cover as few or as many users as you wish. With updates supplied as soon as they're available, you can be sure your documentation is current. For further information, email bsmusales@bsigroup.com.

BSI Group Headquarters

389 Chiswick High Road London W4 4AL UK

Revisions

Our British Standards and other publications are updated by amendment or revision.

We continually improve the quality of our products and services to benefit your business. If you find an inaccuracy or ambiguity within a British Standard or other BSI publication please inform the Knowledge Centre.

Copyright

All the data, software and documentation set out in all British Standards and other BSI publications are the property of and copyrighted by BSI, or some person or entity that owns copyright in the information used (such as the international standardization bodies) and has formally licensed such information to BSI for commercial publication and use. Except as permitted under the Copyright, Designs and Patents Act 1988 no extract may be reproduced, stored in a retrieval system or transmitted in any form or by any means – electronic, photocopying, recording or otherwise – without prior written permission from BSI. Details and advice can be obtained from the Copyright & Licensing Department.

Useful Contacts:

Customer Services

Tel: +44 845 086 9001

Email (orders): orders@bsigroup.com

Email (enquiries): cservices@bsigroup.com

Subscriptions

Tel: +44 845 086 9001

Email: subscriptions@bsigroup.com

Knowledge Centre

Tel: +44 20 8996 7004

Email: knowledgecentre@bsigroup.com

Copyright & Licensing

Tel: +44 20 8996 7070

Email: copyright@bsigroup.com



...making excellence a habit.™