



BSI Standards Publication

Natural gas — Determination of composition and associated uncertainty by gas chromatography

Part 5: Isothermal method for nitrogen, carbon dioxide, C1 to C5 hydrocarbons and C6+ hydrocarbons

National foreword

This British Standard is the UK implementation of EN ISO 6974-5:2014. It supersedes BS EN ISO 6974-5:2001 which is withdrawn.

The UK participation in its preparation was entrusted to Technical Committee PTI/15, Natural Gas and Gas Analysis.

A list of organizations represented on this committee can be obtained on request to its secretary.

This publication does not purport to include all the necessary provisions of a contract. Users are responsible for its correct application.

© The British Standards Institution 2014. Published by BSI Standards Limited 2014

ISBN 978 0 580 79166 6

ICS 75.060

Compliance with a British Standard cannot confer immunity from legal obligations.

This British Standard was published under the authority of the Standards Policy and Strategy Committee on 31 July 2014.

Amendments issued since publication

Date	Text affected
------	---------------

English Version

Natural gas - Determination of composition and associated uncertainty by gas chromatography - Part 5: Isothermal method for nitrogen, carbon dioxide, C1 to C5 hydrocarbons and C6+ hydrocarbons (ISO 6974-5:2014)

Gaz naturel - Détermination de la composition et de l'incertitude associée par chromatographie en phase gazeuse - Partie 5: Méthode isotherme pour l'azote, le dioxyde de carbone, les hydrocarbures C1 à C5 et C6+ (ISO 6974-5:2014)

Erdgas - Bestimmung der Zusammensetzung und der zugehörigen Unsicherheit durch Gaschromatographie - Teil 5: Isothermes Verfahren für Stickstoff, Kohlenstoffdioxid, C1- bis C5-Kohlenwasserstoffe und C6+-Kohlenwasserstoffe (ISO 6974-5:2014)

This European Standard was approved by CEN on 28 June 2014.

CEN members are bound to comply with the CEN/CENELEC Internal Regulations which stipulate the conditions for giving this European Standard the status of a national standard without any alteration. Up-to-date lists and bibliographical references concerning such national standards may be obtained on application to the CEN-CENELEC Management Centre or to any CEN member.

This European Standard exists in three official versions (English, French, German). A version in any other language made by translation under the responsibility of a CEN member into its own language and notified to the CEN-CENELEC Management Centre has the same status as the official versions.

CEN members are the national standards bodies of Austria, Belgium, Bulgaria, Croatia, Cyprus, Czech Republic, Denmark, Estonia, Finland, Former Yugoslav Republic of Macedonia, France, Germany, Greece, Hungary, Iceland, Ireland, Italy, Latvia, Lithuania, Luxembourg, Malta, Netherlands, Norway, Poland, Portugal, Romania, Slovakia, Slovenia, Spain, Sweden, Switzerland, Turkey and United Kingdom.



EUROPEAN COMMITTEE FOR STANDARDIZATION
COMITÉ EUROPÉEN DE NORMALISATION
EUROPÄISCHES KOMITEE FÜR NORMUNG

CEN-CENELEC Management Centre: Avenue Marnix 17, B-1000 Brussels

Foreword

This document (EN ISO 6974-5:2014) has been prepared by Technical Committee ISO/TC 193 "Natural gas".

This European Standard shall be given the status of a national standard, either by publication of an identical text or by endorsement, at the latest by January 2015, and conflicting national standards shall be withdrawn at the latest by January 2015.

Attention is drawn to the possibility that some of the elements of this document may be the subject of patent rights. CEN [and/or CENELEC] shall not be held responsible for identifying any or all such patent rights.

This document supersedes EN ISO 6974-5:2001.

According to the CEN-CENELEC Internal Regulations, the national standards organizations of the following countries are bound to implement this European Standard: Austria, Belgium, Bulgaria, Croatia, Cyprus, Czech Republic, Denmark, Estonia, Finland, Former Yugoslav Republic of Macedonia, France, Germany, Greece, Hungary, Iceland, Ireland, Italy, Latvia, Lithuania, Luxembourg, Malta, Netherlands, Norway, Poland, Portugal, Romania, Slovakia, Slovenia, Spain, Sweden, Switzerland, Turkey and the United Kingdom.

Endorsement notice

The text of ISO 6974-5:2014 has been approved by CEN as EN ISO 6974-5:2014 without any modification.

Contents

Page

Foreword	iv
Introduction	v
1 Scope	1
2 Normative references	2
3 Principle	2
4 Materials	4
5 Apparatus	4
6 Scheme of the configuration	6
7 Procedure	7
7.1 Control of the apparatus.....	7
7.2 Operation of the apparatus.....	8
8 Expression of results	11
8.1 Uncertainty.....	11
8.2 Test report.....	11
Annex A (informative) Example of application	12
Annex B (informative) Procedure for Setting Valve timings and Restrictor Setting	22
Bibliography	24

Foreword

ISO (the International Organization for Standardization) is a worldwide federation of national standards bodies (ISO member bodies). The work of preparing International Standards is normally carried out through ISO technical committees. Each member body interested in a subject for which a technical committee has been established has the right to be represented on that committee. International organizations, governmental and non-governmental, in liaison with ISO, also take part in the work. ISO collaborates closely with the International Electrotechnical Commission (IEC) on all matters of electrotechnical standardization.

The procedures used to develop this document and those intended for its further maintenance are described in the ISO/IEC Directives, Part 1. In particular the different approval criteria needed for the different types of ISO documents should be noted. This document was drafted in accordance with the editorial rules of the ISO/IEC Directives, Part 2 www.iso.org/directives.

Attention is drawn to the possibility that some of the elements of this document may be the subject of patent rights. ISO shall not be held responsible for identifying any or all such patent rights. Details of any patent rights identified during the development of the document will be in the Introduction and/or on the ISO list of patent declarations received www.iso.org/patents.

Any trade name used in this document is information given for the convenience of users and does not constitute an endorsement.

For an explanation on the meaning of ISO specific terms and expressions related to conformity assessment, as well as information about ISO's adherence to the WTO principles in the Technical Barriers to Trade (TBT), see the following URL: [Foreword - Supplementary information](#)

The committee responsible for this document is ISO/TC 193, *Natural Gas*, Subcommittee SC 1, *Analysis of Natural Gas*.

This second edition cancels and replaces the first edition (ISO 6974-5:2000).

ISO 6974 consists of the following parts, under the general title *Natural gas — Determination of composition and associated uncertainty by gas chromatography*:

- *Part 1: General guidelines and calculation of composition*
- *Part 2: Uncertainty calculations*
- *Part 3: Determination of hydrogen, helium, oxygen, nitrogen, carbon dioxide and hydrocarbons up to C₈ using two capillary columns and one packed column*
- *Part 4: Determination of nitrogen, carbon dioxide and C₁ to C₅ and C₆₊ hydrocarbons for a laboratory and on-line measuring system using two columns*
- *Part 5: Isothermal method for nitrogen, carbon dioxide, C₁ to C₅ hydrocarbons and C₆₊ hydrocarbons*
- *Part 6: Determination of helium, oxygen, nitrogen, carbon dioxide and C₁ to C₈ hydrocarbons using three capillary columns*

Introduction

This part of ISO 6974 describes a method for the analysis of natural gas that is commonly used for online process applications, but can be applied to laboratory instruments. The compositional data obtained are used for the calculation of calorific value, density and Wobbe index.

It is assumed that the natural gas does not contain any oxygen at source and that any oxygen which may be present is due to contamination during sampling.

The primary use of this chromatographic method is the calculation of calorific value (CV) according to ISO 6976. It is based on a column switching technique in which multiple columns, chosen for their separating ability for particular groups of components, are switched under automatic control.

Only one injection is necessary and the first phase of the method involves accelerated backflush of C₆+ (which is measured as a recombined “pseudo component” rather than by the summation of individual component measurements). Lighter components (nitrogen, methane, carbon dioxide and ethane) are stored on the appropriate separating column while the heavier, C₃ to C₅ hydrocarbons are eluted. The lighter components are then separated by redirecting carrier gas on to the appropriate column.

A Thermal Conductivity Detector (TCD) is used for measurement of the above components.

When the method is first set up, the repeatability of measurement is established by repetitive analysis of a cylinder of test gas, commonly a typical natural gas. For each component, a control chart showing the mean value, and the bounds representing 2 and 3 standard deviations, is drawn up. Subsequently, this test gas is analysed after each calibration of the analyser, and the results are compared with the data in the control charts. The performance of the analyser is assessed by this procedure.

Any change in the method setup can give rise to differences in component responses and hence (where applied) to calculated uncertainties. In these circumstances fitting data to an existing control chart is not a suitable procedure, and the operations that were undertaken when the method was first set up shall be repeated.

This part of ISO 6974 provides one of the methods that may be used for determining the compositions of natural gas in accordance with ISO 6974-1 and ISO 6974-2.

Natural gas — Determination of composition and associated uncertainty by gas chromatography —

Part 5:

Isothermal method for nitrogen, carbon dioxide, C₁ to C₅ hydrocarbons and C₆₊ hydrocarbons

1 Scope

This part of this International Standard describes a gas chromatographic method for the quantitative determination of the content of nitrogen, carbon dioxide and C₁ to C₅ hydrocarbons individually and a composite C₆₊ measurement, which represents all hydrocarbons of carbon number 6 and above in natural gas samples. It is applicable to the analysis of gases containing constituents within the working ranges given in [Table 1](#).

Table 1 — Component working ranges

Component		Mole fraction	
		%	
		Min.	Max.
Nitrogen	N ₂	0,1	22
Carbon dioxide	CO ₂	0,05	15
Methane	CH ₄	34	100
Ethane	C ₂ H ₆	0,1	23
Propane	C ₃ H ₈	0,05	10
iso-Butane	i-C ₄ H ₁₀	0,01	2,0
n-Butane	n-C ₄ H ₁₀	0,01	2,0
neo-Pentane	neo-C ₅ H ₁₂	0,005	0,35
iso-Pentane	i-C ₅ H ₁₂	0,005	0,35
n-Pentane	n-C ₅ H ₁₂	0,005	0,35
Hexanes +	C ₆₊	0,005	0,35

NOTE 1 The working ranges in [Table 1](#) are those for which the method has been shown to be satisfactory, and are offered for guidance. However, there is no reason why wider ranges should not be used, provided that the successful measurement of such wider ranges has been demonstrated.

NOTE 2 Hydrocarbons above n-pentane are expressed as the “pseudo-component” C₆₊ which is measured as one composite peak and calibrated as such. The properties of C₆₊ are calculated from an extended analysis of the individual C₆ and higher hydrocarbons.

NOTE 3 Oxygen is not a normal constituent of natural gas and would not be expected to be present in gas sampled to an online instrument. If any oxygen is present as a result of air contamination, it will be measured with the nitrogen. The resulting measured (nitrogen + oxygen) value will be in error to a small extent because of the slight difference between the detector responses of oxygen and nitrogen.

NOTE 4 The helium and argon contents are assumed to be sufficiently small and unvarying that they need not be analysed for.

NOTE 5 The gas sample shall not contain any hydrocarbon condensate and/or water.

2 Normative references

The following documents, in whole or in part, are normatively referenced in this document and are indispensable for its application. For dated references, only the edition cited applies. For undated references, the latest edition of the referenced document (including any amendments) applies.

ISO 6974-1, *Natural gas — Determination of composition and associated uncertainty by gas chromatography — Part 1: General guidelines and calculation of composition*

ISO 6974-2, *Natural gas — Determination of composition and associated uncertainty by gas chromatography — Part 2: Uncertainty calculations*

3 Principle

[Figure 1](#) is a flowchart showing the steps involved in the analytical process. It is based on more detailed flowcharts in ISO 6974-1 and ISO 6974-2, simplified to represent the procedure described in this part. References are given at each step to the relevant clause in this part and, where appropriate, to the relevant clauses in ISO 6974-1 and ISO 6974-2.

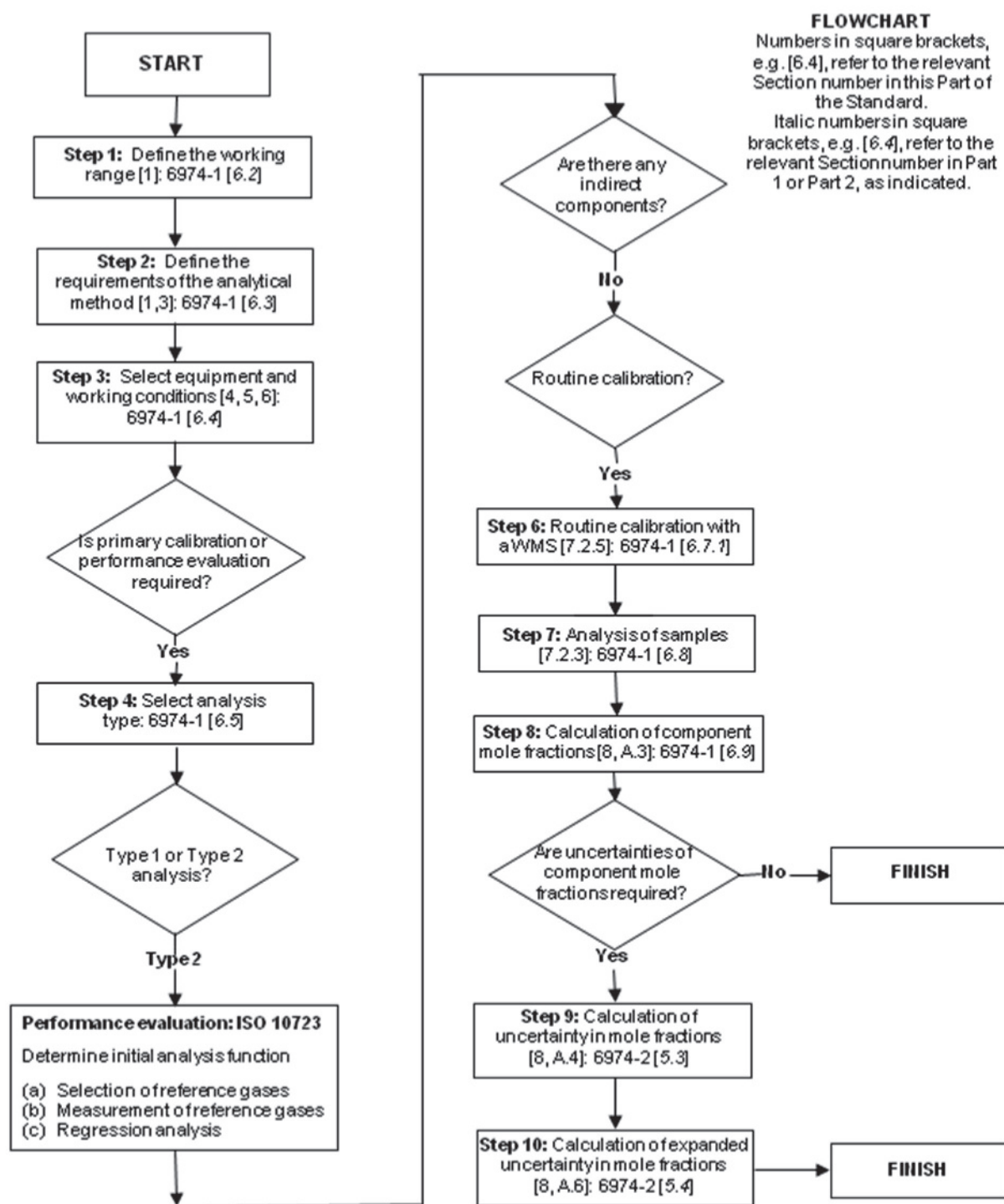

Figure 1 — Operational flowchart

NOTE The steps referred to in Figure 1 are identical to the steps in flowcharts A and B in ISO 6974-1 Step 5 refers to the use of relative response factors for indirectly measured components. Indirect components are not used in this part of ISO 6974, so step 5 is not used.

The chromatographic method uses a column switching/backflush arrangement, configured as shown in Figure 2. The sample is injected onto a boiling-point column which is divided into short and long sections (columns 1 and 2). The long section (column 2) provides separation of C₃ to C₅ hydrocarbons, while C₆ and heavier hydrocarbons are retained on the short section (column 1), from which they are

backflushed and measured by the detector as a single peak. Two six-port valves can handle the sample injection and backflushing operations, or they may be dealt with together by a single 10-port valve.

Nitrogen, carbon dioxide, methane and ethane pass rapidly and unresolved through the boiling-point column onto a porous polymer bead column (column 3), suitable for their separation. A six-port valve either connects this column or by-passes it during measurement of C₃ to C₅ components.

The separations that occur in the columns are as follows:

Column 1 Retains C₆+ components ready for backflushing as one composite peak.

Column 2 Separates Propane, iso-Butane, n-Butane, neo-Pentane, iso-Pentane and n-Pentane, (which elute after C₆+ has left column 1).

Column 3 Stores and separates Nitrogen, Methane, Carbon Dioxide and Ethane which elute after n-Pentane has left column 2.

4 Materials

4.1 Carrier gas, Helium (He), ≥99,995 % pure, free from oxygen and water.

4.2 Auxiliary gases, compressed air, for valve actuation (If consumption is low, carrier gas may be used as an alternative for valve actuation).

4.3 Reference materials.

4.3.1 Reference gases, according to ISO 6974-1.

4.3.2 Gas mixture containing n-Pentane and 2,2-Di-Me-butane, used to check valve timings (see [Annex B](#)).

5 Apparatus

5.1 Gas chromatograph, capable of isothermal operation and equipped with TCD.

5.2 Column oven, temperature range 70 °C to 105 °C, capable of being maintained to within ±0,1 °C.

5.3 Valve oven, controlled over the temperature range 70 °C to 105 °C, or valves fitted in the column oven.

5.4 Pressure regulator, to give suitable carrier gas flow rates

5.5 Injection device, V1, six-port sample injection valve

5.6 Backflush valve, V2, six-port, to allow rapid backflush of C₆+ components. As described in [section 3](#), a single 10-port valve may be used for both these tasks. The operating principle is the same.

5.7 Column isolation valve, V3, six-port. This directs the carrier gas through the porous polymer bead column (column 3), or by-passes it.

5.8 Columns, The columns must satisfy the performance requirements given in [7.2.4](#). The following packing materials and column dimensions, given as examples, should be satisfactory, for use with conventional and readily available injection valves and TCDs. Any alternative combination of columns which provide similar separations and satisfy the performance requirements may be used. Micro-packed

or even capillary columns can be chosen, with appropriately sized injection and detector systems, in which case packing or coating details would be different.

5.9 Tube and packing.

5.9.1 Configuration 1

5.9.1.1 Column 1, 28 % DC200/500 on 45/60 mesh chromosorb P-AW, 0,75 m (2,5 foot) long, 2 mm i.d. (1/8 in o.d.).

5.9.1.2 Column 2, 28 % DC200/500 on 45/60 mesh chromosorb P-AW, 5,2 m (17 foot) long, 2 mm i.d. (1/8 in o.d.).

5.9.1.3 Column 3, 15 % DC200/500 on 50/80 mesh Porapak N, 2,4 m (8 ft) long, 2 mm i.d. (1/8 in o.d.).

5.9.2 Configuration 2.

5.9.2.1 Column 1, oxy-dipropionitrile on Porasil C, 0,3 m (1 foot) long, 0,75 mm i.d. (1/16 in o.d.).

5.9.2.2 Column 2, 20 % SF-96 on 80-100 mesh chromosorb W, 2,1 m (7 foot) long, 0,75 mm i.d. (1/16 in o.d.).

5.9.2.3 Column 3, HayeSep N, 2,1 m (7 foot) long, 0,75 mm i.d. (1/16 in o.d.).

5.10 Method of packing, any method which results in uniform column packing may be used.

NOTE The following method is suitable.

The column outlet is closed with a sintered disc or glass wool plug. A reservoir containing rather more packing than is needed to fill the column is connected to the inlet and a pressure of 0,4 MPa of nitrogen is applied to this reservoir. The flow of packing into the column is assisted by vibration. When the column is full, allow the pressure to decay slowly before disconnecting the reservoir.

5.11 Thermal Conductivity Detector (TCD), with a time constant of not greater than 0,1 s, and internal volume appropriate for the column sizes and flow rate used.

5.12 Controller/Peak Measurement System. Wide range (0 V to 1 V), capable of measuring peaks on a sloping baseline. Be enabled to control automatic operation of the valves according to a sequence selected by the operator.

5.13 Auxiliary valves, tubing and other accessories, to control the flow of sample gas to the chromatograph and for shutting off this flow for a defined period of time before injection.

6 Scheme of the configuration

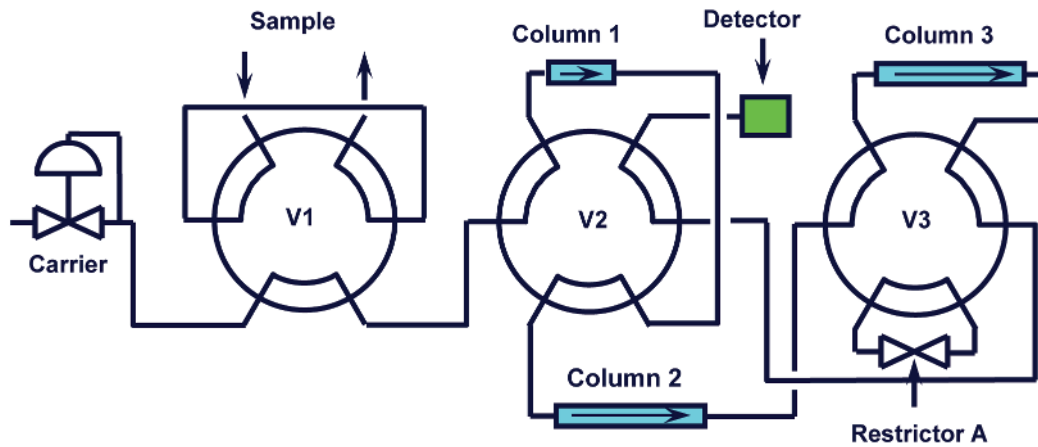

a) Initial configuration: all valves in position 1

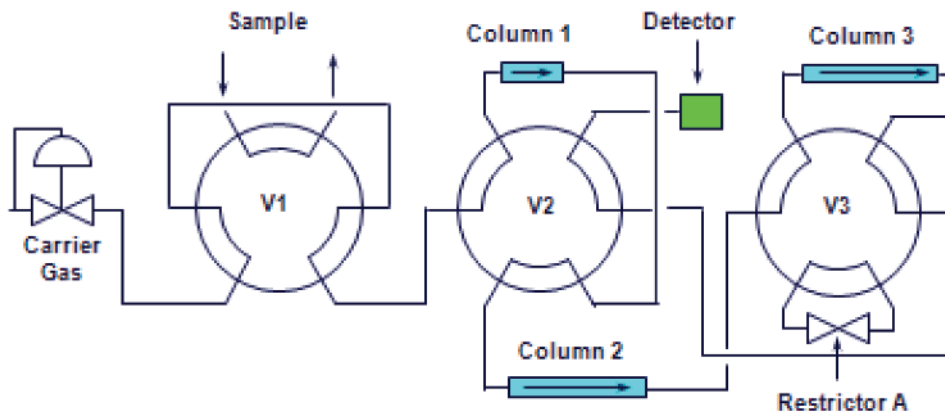

b) Sample injection: V1 to position 2

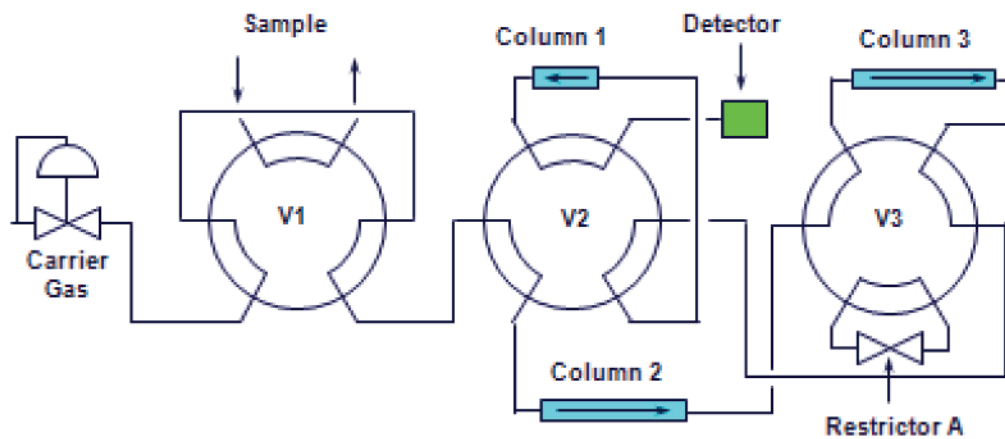

c) Backflush C₆+: V2 to position 2

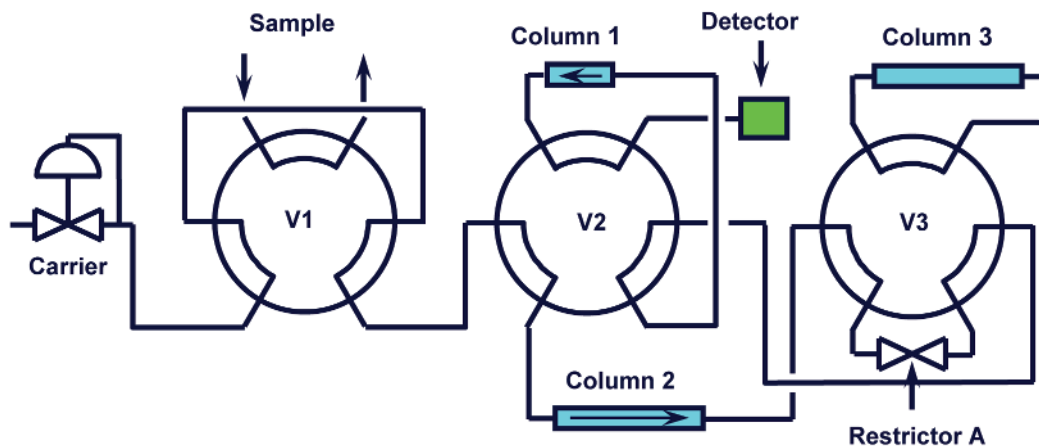

d) Isolate N_2 , C_1 , CO_2 , C_2 ; measure C_3 to C_5 : V3 to position 2

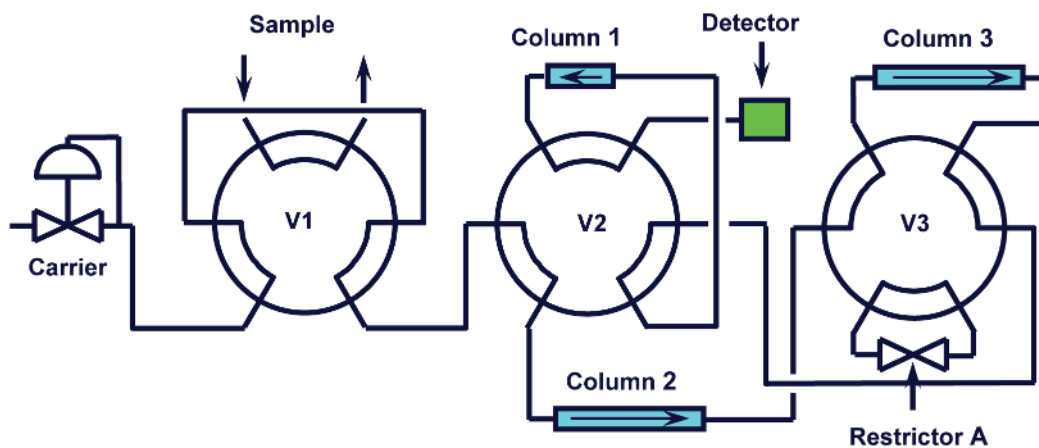

e) Reconnect column 3 - measure N_2 , C_1 , CO_2 , C_2 : V3 to position 1

Figure 2 — Scheme of the configuration

7 Procedure

7.1 Control of the apparatus

Set up the gas chromatograph according to the manufacturer's instructions.

7.1.1 Column Conditioning

The columns described in 5.8 and 5.9 do not need conditioning or activation, and are generally being used well within their temperature limits. However a small amount of column bleed due to lower-boiling impurities may be evident on first use, and result in unstable baselines. Operation of the analyser overnight with carrier gas flowing but no sample injections, at a temperature 20 °C to 40 °C above the recommended operating temperature should eliminate this effect.

Residual adsorbed moisture in the lines supplying carrier gas or sample gas can give rise to unexplained peaks over and above those expected. Operation overnight under the recommended conditions with sample injection should eliminate these effects.

7.2 Operation of the apparatus

7.2.1 Analytical method

Examples of the operating conditions for configurations 1 (5.9.1) and 2 (5.9.2) are given in [Tables 2](#) and [3](#).

Table 2 — Example of instrument conditions, configuration 1

	Column 1	Column 2	Column 3
Stationary phase	Silicone oil DC 200/500	Silicone oil DC 200/500	Silicone oil DC 200/500
Loading %	28 %	28 %	15 %
Support	Chromosorb P-AW	Chromosorb P-AW	
Active solid			Porapak N
ASTM mesh size	45/60	45/60	50/80
Column length	0,75 m	5,2 m	2,4 m
Column i.d.	2 mm	2 mm	2 mm
material	Stainless steel		
Temperature	100 °C		
Carrier gas	Helium		
Supply pressure	4 bar		
Flowrate	28 ml/min		
Detector	Thermal Conductivity		
Detector Temp.	100 °C minimum		
Injection device	Valve		
Injector Temp.	100 °C		
Sample size	1,0 ml		

Table 3 — Example of instrument conditions, configuration 2

	Column 1	Column 2	Column 3
Stationary phase	Oxy-dipropionitrile	Silicone oil SF-96	Silicone oil DC 200/500
Loading %	28 %	20 %	15 %
Support		Chromosorb P-AW	
Active solid	Porasil C		HayeSep N
ASTM mesh size	80/100	80/100	80/100
Column length	0,3 m	2,1 m	2,1 m
Column i.d.	0,75 mm	0,75 mm	0,75 mm
material	Stainless steel		
Temperature	80 °C		
Carrier gas	Helium		
Supply pressure	4 bar		
Flowrate	28 ml/min		
Detector	Thermal Conductivity		
Detector Temp.	80 °C minimum		
Injection device	Valve		
Injector Temp.	80 °C		
Sample size	0,25 ml		

7.2.2 Sample introduction

Purge the sample valve with the gas to be analysed, using at least 20 times the volume of the valve and associated pipe work.

Stop the purge to enable the gas to reach the temperature of the valve and ambient pressure, and then start the analytical cycle, injecting the sample and switching the valves as required.

If this volume of sample is not enough to purge the valve, then contamination by air or by the previous sample will be evident. If either occurs, then use a larger volume of sample for purging.

NOTE The sample loop should be purged with gas for a precise time, at a defined rate, and the sample should then be allowed to equilibrate to ambient pressure before injection. In the absence of equipment which can confirm the latter, there should be a defined time between sample valve shut off and injection.

7.2.3 Analysis

The analytical system shown in [Figure 2](#) consists of one six-port sample injection valve, V1, one six-port backflush valve, V2, and one six-port by-pass valve V3. Restrictor A maintains the pneumatic balance of the system when column 3 is isolated. The detailed setting-up procedure is given in [Annex B](#). (One 10-port valve may be used in place of the six-port valves V1 and V2, controlling both sample injection and backflushing of column 1.).

The timings of the valve switching operations must ensure that:

- V2 is returned to the backflush position (position 2) after all the n-pentane leaves column 1 but before the lowest C₆ isomer leaves column 1 on its way to column 2.
- V3 is switched to isolate column 3 (position 2) before any propane leaves column 2 (on its way to column 3) and after all the ethane has left column 2 and entered column 3.

- c) V3 is not returned to reconnect column 3 (position 1) until all the n-pentane has been detected, having emerged from column 2 via column 1.

A typical chromatogram is shown in [Figure 3](#).

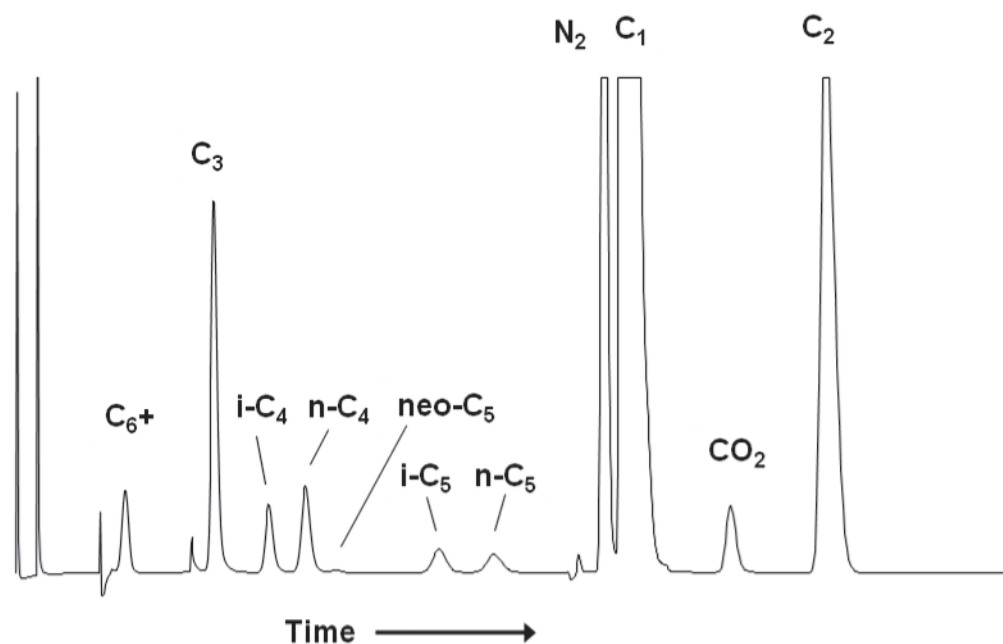

Figure 3 — A typical chromatogram

7.2.4 Peak resolution

It is important that all components are measured without interference from others. The resolution between neighbouring peaks can be assessed according to ISO 7504:2001, 3.3.4.4. Although the resolutions of all peaks are important, there are particular pairs of peaks which are critical: their satisfactory resolution ensures that of other pairs (see [Table 4](#)).

The resolution required is likely to vary with the component uncertainties which are deemed to be acceptable for particular applications. Two values are quoted below - medium resolution, which should be available if the procedure is implemented normally, and high resolution, which may require modifications to column sizes, temperature and flow rate, and is likely to involve a longer analysis time.

NOTE A resolution of 1.5 or higher indicates baseline separation between symmetrical peaks. A resolution of 1.0 is taken to be the minimum value for quantitative measurement.

Table 4 — Peak resolution

Component 1	Component 2	Medium Resolution	High Resolution
i-Butane	n-Butane	1,5	2,0
Nitrogen	Methane	1,25	2,0
Carbon dioxide	Ethane	2,0	2,3

7.2.5 Calibration

Calibrate the equipment according to the procedures in ISO 6974-1.

8 Expression of results

Refer to ISO 6974-1.

8.1 Uncertainty

Refer to ISO 6974-2.

8.2 Test report

Refer to ISO 6974-1.

Annex A (informative)

Example of application

A.1 General considerations

In this example, the analysis is considered to be of Type 2. Instrument response for all components is assumed to be first order with zero intercept. All components are measured directly against the same component in the Working Measurement Standard (WMS). No Other Components were determined. No pressure correction was employed, either during calibration or analysis of sample. Multiple operation methods (with or without bridging) were not employed.

Performance evaluation of the instrument according to ISO 10723 was carried out prior to calibration and analysis using seven test gases, each containing 11 components. From prior knowledge of the intended application and likely composition of gases to be presented to the analyser, the Working Range of the instrument is decided to be that given in [Table A.1](#).

Table A.1 — Working range of the analyser

	minimum/mol%	maximum/mol%
nitrogen	0,20	12,20
carbon dioxide	0,05	8,00
methane	63,50	98,50
ethane	0,10	14,20
propane	0,05	7,80
i-butane	0,01	1,20
n-butane	0,01	1,20
neo-pentane	0,01	0,34
i-pentane	0,01	0,34
n-pentane	0,01	0,34
C ₆ +	0,05	0,34

Performance evaluation resulted in the outputs shown in [Table A.2](#). The mean errors, $\bar{\delta}_l$, shown in the second column of [Table A.2](#), are deemed to be sufficiently close to zero that correction is unnecessary (see ISO 6974-1:2012, 6.9.4).

Table A.2 — Output from performance evaluation of the analyser

	$\bar{\delta}_l$ /mol%	$u^2(\bar{\delta}_l)$ /mol% ²	$\overline{u^2(\delta_l)}$ /mol% ²
nitrogen	-0,026 937 130	0,000 309 597	0,002 748 444
carbon dioxide	-0,011 354 153	0,000 186 463	0,000 916 820
methane	0,085 980 308	0,000 945 917	0,028 341 745
ethane	-0,030 749 812	0,000 600 030	0,004 667 961
propane	-0,014 790 556	0,000 180 682	0,001 797 461
i-butane	-0,003 493 228	0,000 009 708	0,000 049 207
n-butane	0,001 375 116	0,000 009 970	0,000 021 061
neo-pentane	-0,000 373 260	0,000 000 099	0,000 000 146
i-pentane	0,000 278 938	0,000 001 441	0,000 004 245
n-pentane	0,000 395 722	0,000 000 985	0,000 001 035
C ₆ +	-0,000 332 000	0,000 000 756	0,000 002 234

In the example given the mole fractions and their (standard) uncertainties are expressed to a large number of significant figures purely to aid checking of calculations and software. Reporting of results should follow the guidelines indicated in [Clause A.6](#).

A.2 Calibration

Calibration was performed using 10 injections of the WMS and resulted in the responses listed in [Table A.3](#).

Table A.3 — Calibration of analyser with WMS

Working Measurement Standard		Response to repeat injections of WMS, $y_{i,c}$																	
$x_{i,c}$	$u(x_{i,c})$																		
N ₂	0,007 700	45 418 913	45 419 334	45 442 468	45 419 580	45 416 382	45 415 368	45 366 878	45 320 974	45 318 263	45 356 454								
CO ₂	0,006 300	40 572 613	40 581 705	40 601 104	40 576 934	40 577 794	40 533 155	40 529 141	40 489 430	40 473 732	40 489 807								
CH ₄	0,035 000	668 630 412	668 810 045	668 869 106	668 450 572	668 514 839	667 962 151	668 021 535	667 423 648	667 503 177	667 839 832								
C ₂ H ₆	0,011 000	95 587 376	95 617 094	95 647 647	95 609 735	95 589 062	95 473 045	95 479 716	95 420 277	95 366 831	95 371 596								
C ₃ H ₈	0,010 900	57 744 920	57 749 069	57 773 820	57 743 122	57 726 205	57 691 084	57 690 919	57 635 967	57 617 072	57 642 576								
i-C ₄ H ₁₀	0,002 000	10 042 575	10 047 566	10 050 301	10 045 957	10 018 568	10 033 946	10 035 598	10 019 507	10 012 115	10 021 785								
n-C ₄ H ₁₀	0,002 030	10 717 709	10 721 066	10 726 790	10 719 269	10 643 518	10 714 279	10 716 121	10 682 900	10 671 799	10 699 937								
neo-C ₅ H ₁₂	0,000 930	2 467 959	2 464 967	2 471 477	2 472 487	2 422 200	2 467 128	2 467 231	2 450 889	2 439 380	2 464 724								
i-C ₅ H ₁₂	0,000 450	2 602 386	2 588 249	2 599 693	2 595 334	2 597 443	2 595 279	2 589 539	2 588 531	2 585 677	2 586 644								
n-C ₅ H ₁₂	0,000 440	2 670 849	2 667 285	2 674 288	2 671 577	2 673 610	2 667 543	2 665 677	2 656 744	2 667 690	2 658 937								
n-C ₆ H ₁₄	0,000 550	2 891 785	2 891 302	2 894 087	2 889 788	2 893 454	2 888 157	2 888 979	2 885 194	2 887 248	2 887 136								

For each component the assumed analysis function was calculated from the mean of the 10 responses of the instrument to that component according to Formula (6) of ISO 6974-1. The coefficients of the calibration function $b_{1,j}$ and their uncertainties are shown in [Table A.4](#).

Table A.4 — Mean responses, coefficients of the assumed analysis function and their uncertainties

	$\overline{y_{i,c}}$	$(\overline{y_{i,c}})$	$b_{1,i}$	$u(b_{1,i})$	$u(\overline{b_{1,i}})$
N ₂	45 389 461	14 233	9,894 4E-08	1,724 6E-10	5,453 6E-11
CO ₂	40 542 542	14 490	8,191 4E-08	1,581 3E-10	5,000 4E-11
CH ₄	668 202 532	165 777	1,204 5E-07	6,030 4E-11	1,907 0E-11
C ₂ H ₆	95 516 238	33 698	7,298 2E-08	1,180 1E-10	3,731 7E-11
C ₃ H ₈	57 701 475	17 268	5,694 8E-08	1,896 7E-10	5,997 9E-11
i-C ₄ H ₁₀	10 032 792	4 385	4,971 7E-08	2,005 3E-10	6,341 2E-11
n- C ₄ H ₁₀	10 701 339	8 544	4,736 8E-08	1,934 3E-10	6,116 8E-11
neo-C ₅ H ₁₂	2 458 844	5 191	4,485 8E-08	3,899 0E-10	1,233 0E-10
i-C ₅ H ₁₂	2 592 878	1 861	4,308 0E-08	1,762 8E-10	5,574 6E-11
n-C ₅ H ₁₂	2 667 420	1 837	4,131 3E-08	1,673 9E-10	5,293 3E-11
n-C ₆ H ₁₄	2 889 713	919	3,779 4E-08	1,907 1E-10	6,030 8E-11

A.3 Calculation of mole fractions

A.3.1 Mean normalization method (see ISO 6974-1:2012, 6.9.2)

Analysis was performed using 10 injections of unknown sample and the responses are shown in [Table A.5](#).

Table A.5 — Analysis of the unknown sample — Responses

	Response to repeat injections of unknown, $y_{i,l}$																				
	10 236 417	10 240 495	10 246 618	10 244 738	10 241 295	10 232 300	10 229 693	10 222 707	10 219 179	10 216 049	758 495 738	34 401 492	26 410 948	3 012 585	1 089 552	2 233 201	6 501 407	6 820 029	7 506 943		
N ₂	18 415 310	18 422 045	18 435 304	18 434 085	18 424 393	18 411 116	18 401 539	18 383 646	18 380 028	18 377 358	758 495 738	34 401 492	26 410 948	3 012 585	1 089 552	2 233 201	6 501 407	6 820 029	7 506 943		
CO ₂	758 495 738	34 419 925	34 435 930	34 431 624	34 418 949	34 391 132	34 382 000	34 338 050	34 340 359	34 327 857	758 495 738	34 401 492	26 410 948	3 012 585	1 089 552	2 233 201	6 501 407	6 820 029	7 506 943		
CH ₄	34 401 492	26 417 468	26 432 384	26 425 904	26 413 480	26 403 122	26 390 844	26 372 530	26 357 254	26 359 524	758 495 738	34 401 492	26 410 948	3 012 585	1 089 552	2 233 201	6 501 407	6 820 029	7 506 943		
C ₂ H ₆	26 410 948	3 013 402	3 018 742	3 011 698	3 013 273	3 011 849	3 010 653	3 002 502	3 006 436	3 007 862	758 495 738	34 401 492	26 410 948	3 012 585	1 089 552	2 233 201	6 501 407	6 820 029	7 506 943		
C ₃ H ₈	3 012 585	1 094 049	1 099 073	1 083 432	1 091 537	1 097 826	1 089 512	1 082 269	1 096 913	1 098 003	758 495 738	34 401 492	26 410 948	3 012 585	1 089 552	2 233 201	6 501 407	6 820 029	7 506 943		
i-C ₄ H ₁₀	1 089 552	2 242 986	2 245 323	2 230 482	2 238 311	2 247 109	2 232 392	2 229 004	2 243 788	2 240 447	758 495 738	34 401 492	26 410 948	3 012 585	1 089 552	2 233 201	6 501 407	6 820 029	7 506 943		
n-C ₄ H ₁₀	2 233 201	6 506 790	6 511 176	6 509 851	6 508 789	6 499 341	6 504 860	6 527 695	6 498 443	6 491 912	758 495 738	34 401 492	26 410 948	3 012 585	1 089 552	2 233 201	6 501 407	6 820 029	7 506 943		
neo-C ₅ H ₁₂	6 501 407	6 826 995	6 825 102	6 829 689	6 825 003	6 815 522	6 800 746	6 830 090	6 798 891	6 806 755	758 495 738	34 401 492	26 410 948	3 012 585	1 089 552	2 233 201	6 501 407	6 820 029	7 506 943		
i-C ₅ H ₁₂	6 820 029	7 509 958	7 510 995	7 510 464	7 507 098	7 503 406	7 503 020	7 493 968	7 490 009	7 490 287	758 495 738	34 401 492	26 410 948	3 012 585	1 089 552	2 233 201	6 501 407	6 820 029	7 506 943		
n-C ₅ H ₁₂	7 506 943																				
C ₆₊																					

The mean responses, calculated according to ISO 6974-1:2012, Formula (7) are shown in [Table A.6](#).

Table A.6 — Analysis of the unknown sample — Mean responses and uncertainties

Component	\bar{y}_i	$u(\bar{y}_i)$	$u(y_{i,l})$
N ₂	10 232 949	3 425	10 830
CO ₂	18 408 482	6 919	21 881
CH ₄	757 934 636	226 900	717 522
C ₂ H ₆	34 388 732	12 816	40 527
C ₃ H ₈	26 398 346	8 572	27 106
i-C ₄ H ₁₀	3 010 900	1 404	4 441
n- C ₄ H ₁₀	1 092 217	1 910	6 040
neo-C ₅ H ₁₂	2 238 304	2 087	6 600
i-C ₅ H ₁₂	6 506 026	3 061	9 678
n-C ₅ H ₁₂	6 817 882	3 746	11 844
C ₆₊	7 502 615	2 606	8 240

The raw mole fractions were calculated according to ISO 6974-1:2012, Formula (9) and are shown in [Table A.7](#).

The mole fractions were calculated according to ISO 6974-1:2012, Formula (11) (note that x_{oc} is zero in this instance) and are shown in [Table A.7](#).

Table A.7 — Raw mole fractions, mole fractions and their uncertainties

Component	x_i^*	$u(x_i^*)$	x_i	$u(x_i)$
N ₂	1,012	0,019 463	1,023	0,019 479
CO ₂	1,508	0,011 153	1,524	0,011 160
CH ₄	91,291	0,067 999	92,239	0,034 802
C ₂ H ₆	2,510	0,024 978	2,536	0,024 668
C ₃ H ₈	1,503	0,014 914	1,519	0,014 886
i-C ₄ H ₁₀	0,150	0,002 675	0,151	0,002 701
n- C ₄ H ₁₀	0,052	0,001 818	0,052	0,001 836
neo-C ₅ H ₁₂	0,100	0,000 351	0,101	0,000 363
i-C ₅ H ₁₂	0,280	0,000 852	0,283	0,000 886
n-C ₅ H ₁₂	0,282	0,000 610	0,285	0,000 653
C ₆₊	0,284	0,000 724	0,286	0,000 763
total	98,972		100,000	

A.3.2 Run-by-run normalization method (see ISO 6974-1:2012, 6.9.3)

For each injection of unknown the raw mole fractions were calculated according to ISO 6974-1:2012, Formula (13) and are shown in [Table A.8](#).

For each injection the mole fractions were calculated according to ISO 6974-1:2012, Formula (15) of . Note that x_{oc} is zero in this instance and are shown in [Table A.9](#).

Table A.8 — Raw mole fractions and their uncertainties for each run

Component	Run 1		Run 2		Run 3		Run 4		Run 5	
	$x_{i,l}^*$	$u(x_{i,l}^*)$	$x_{i,l}^*$	$u(x_{i,l}^*)$	$x_{i,l}^*$	$u(x_{i,l}^*)$	$x_{i,l}^*$	$u(x_{i,l}^*)$	$x_{i,l}^*$	$u(x_{i,l}^*)$
N ₂	1,013	0,061 5	1,013	0,061 5	1,014	0,061 5	1,014	0,061 5	1,013	0,061 5
CO ₂	1,508	0,035 2	1,509	0,035 2	1,510	0,035 2	1,510	0,035 2	1,509	0,035 2
CH ₄	91,359	0,212 6	91,348	0,212 6	91,419	0,212 6	91,386	0,212 6	91,319	0,212 6
C ₂ H ₆	2,511	0,079 0	2,512	0,079 0	2,513	0,079 0	2,513	0,079 0	2,512	0,079 0
C ₃ H ₈	1,504	0,047 1	1,504	0,047 1	1,505	0,047 1	1,505	0,047 1	1,504	0,047 1
i-C ₄ H ₁₀	0,150	0,008 4	0,150	0,008 4	0,150	0,008 4	0,150	0,008 4	0,150	0,008 4
n-C ₄ H ₁₀	0,052	0,005 7	0,052	0,005 7	0,052	0,005 7	0,051	0,005 7	0,052	0,005 7
neo-C ₅ H ₁₂	0,100	0,001 1	0,101	0,001 1	0,101	0,001 1	0,100	0,001 1	0,100	0,001 1
i-C ₅ H ₁₂	0,280	0,002 7	0,280	0,002 7	0,280	0,002 7	0,280	0,002 7	0,280	0,002 7
n-C ₅ H ₁₂	0,282	0,001 9	0,282	0,001 9	0,282	0,001 9	0,282	0,001 9	0,282	0,001 9
C ₆₊	0,284	0,002 1	0,284	0,002 1	0,284	0,002 1	0,284	0,002 1	0,284	0,002 1
total	99,042		99,035		99,110		99,075		99,006	
Component	Run 6		Run 7		Run 8		Run 9		Run 10	
	$x_{i,l}^*$	$u(x_{i,l}^*)$	$x_{i,l}^*$	$u(x_{i,l}^*)$	$x_{i,l}^*$	$u(x_{i,l}^*)$	$x_{i,l}^*$	$u(x_{i,l}^*)$	$x_{i,l}^*$	$u(x_{i,l}^*)$
N ₂	1,012	0,061 5	1,012	0,061 5	1,011	0,061 5	1,011	0,061 5	1,011	0,061 5
CO ₂	1,508	0,035 2	1,507	0,035 2	1,506	0,035 2	1,506	0,035 2	1,505	0,035 2
CH ₄	91,255	0,212 5	91,242	0,212 5	91,221	0,212 5	91,192	0,212 5	91,169	0,212 5
C ₂ H ₆	2,510	0,079 0	2,509	0,079 0	2,506	0,079 0	2,506	0,079 0	2,505	0,079 0
C ₃ H ₈	1,504	0,047 1	1,503	0,047 1	1,502	0,047 1	1,501	0,047 1	1,501	0,047 1
i-C ₄ H ₁₀	0,150	0,008 4	0,150	0,008 4	0,149	0,008 4	0,149	0,008 4	0,150	0,008 4
n-C ₄ H ₁₀	0,052	0,005 7	0,052	0,005 7	0,051	0,005 7	0,052	0,005 7	0,052	0,005 7
neo-C ₅ H ₁₂	0,101	0,001 1	0,100	0,001 1	0,100	0,001 1	0,101	0,001 1	0,101	0,001 1
i-C ₅ H ₁₂	0,280	0,002 7	0,280	0,002 7	0,281	0,002 7	0,280	0,002 7	0,280	0,002 7
n-C ₅ H ₁₂	0,282	0,001 9	0,281	0,001 9	0,282	0,001 9	0,281	0,001 9	0,281	0,001 9
C ₆₊	0,284	0,002 1	0,284	0,002 1	0,283	0,002 1	0,283	0,002 1	0,283	0,002 1
total	98,937		98,920		98,893		98,862		98,838	

Table A.9 — Mole fractions and their uncertainties for each run

Component	Run 1		Run 2		Run 3		Run 4		Run 5	
	$x_{i,l}$	$u(x_{i,l})$	$x_{i,l}$	$u(x_{i,l})$	$x_{i,l}$	$u(x_{i,l})$	$x_{i,l}$	$u(x_{i,l})$	$x_{i,l}$	$u(x_{i,l})$
N ₂	1,023	0,061 6	1,023	0,061 6	1,023	0,061 5	1,023	0,061 5	1,023	0,061 6
CO ₂	1,523	0,035 3	1,524	0,035 3	1,524	0,035 2	1,524	0,035 3	1,524	0,035 3
CH ₄	92,242	0,110 0	92,238	0,110 0	92,239	0,109 9	92,239	0,109 9	92,236	0,110 0
C ₂ H ₆	2,535	0,078 0	2,537	0,078 0	2,536	0,077 9	2,536	0,077 9	2,537	0,078 0
C ₃ H ₈	1,519	0,047 0	1,519	0,047 0	1,519	0,047 0	1,519	0,047 0	1,519	0,047 1
i-C ₄ H ₁₀	0,151	0,008 5	0,151	0,008 5	0,151	0,008 5	0,151	0,008 5	0,151	0,008 5
n-C ₄ H ₁₀	0,052	0,005 8	0,052	0,005 8	0,053	0,005 8	0,052	0,005 8	0,052	0,005 8
neo-C ₅ H ₁₂	0,101	0,001 1	0,102	0,001 1	0,102	0,001 1	0,101	0,001 1	0,101	0,001 1
i-C ₅ H ₁₂	0,283	0,002 8	0,283	0,002 8	0,283	0,002 8	0,283	0,002 8	0,283	0,002 8
n-C ₅ H ₁₂	0,284	0,002 1	0,285	0,002 1	0,284	0,002 1	0,285	0,002 1	0,285	0,002 1
C ₆₊	0,286	0,002 4	0,287	0,002 4	0,286	0,002 4	0,286	0,002 4	0,287	0,002 4
total	100,000		100,000		100,000		100,000		100,000	
Component	Run 6		Run 7		Run 8		Run 9		Run 10	
	$x_{i,l}$	$u(x_{i,l})$	$x_{i,l}$	$u(x_{i,l})$	$x_{i,l}$	$u(x_{i,l})$	$x_{i,l}$	$u(x_{i,l})$	$x_{i,l}$	$u(x_{i,l})$
N ₂	1,023	0,061 6	1,023	0,061 6	1,023	0,061 6	1,023	0,061 7	1,023	0,061 7
CO ₂	1,524	0,035 3	1,524	0,035 3	1,523	0,035 3	1,523	0,035 3	1,523	0,035 3
CH ₄	92,236	0,110 1	92,238	0,110 1	92,242	0,110 1	92,242	0,110 2	92,241	0,110 2
C ₂ H ₆	2,537	0,078 0	2,537	0,078 0	2,534	0,078 1	2,535	0,078 1	2,535	0,078 1
C ₃ H ₈	1,520	0,047 1	1,519	0,047 1	1,519	0,047 1	1,518	0,047 1	1,519	0,047 1
i-C ₄ H ₁₀	0,151	0,008 5	0,151	0,008 5	0,151	0,008 5	0,151	0,008 6	0,151	0,008 6
n-C ₄ H ₁₀	0,053	0,005 8	0,052	0,005 8	0,052	0,005 8	0,053	0,005 8	0,053	0,005 8
neo-C ₅ H ₁₂	0,102	0,001 2	0,101	0,001 1	0,101	0,001 1	0,102	0,001 2	0,102	0,001 2
i-C ₅ H ₁₂	0,283	0,002 8	0,283	0,002 8	0,284	0,002 8	0,283	0,002 8	0,283	0,002 8
n-C ₅ H ₁₂	0,285	0,002 1	0,284	0,002 1	0,285	0,002 1	0,284	0,002 1	0,285	0,002 1
C ₆₊	0,287	0,002 4	0,287	0,002 4	0,286	0,002 4	0,286	0,002 4	0,286	0,002 4
total	100,000		100,000		100,000		100,000		100,000	

For each component the mean of the mole fractions are computed from the mole fractions obtained from each injection using ISO 6974-1:2012, Formula (16) and are shown in [Table A.10](#).

Table A.10 — Mean mole fractions and their uncertainties

Component	\bar{x}_i	$u(\bar{x}_i)$
N ₂	1,023	0,019 479
CO ₂	1,524	0,011 160
CH ₄	92,239	0,034 802
C ₂ H ₆	2,536	0,024 668
C ₃ H ₈	1,519	0,014 886
i-C ₄ H ₁₀	0,151	0,002 701
n- C ₄ H ₁₀	0,052	0,001 836
neo-C ₅ H ₁₂	0,101	0,000 363
i-C ₅ H ₁₂	0,283	0,000 886
n-C ₅ H ₁₂	0,285	0,000 653
C ₆₊	0,286	0,000 763

A.4 Calculation of uncertainties of mole fractions

A.4.1 Mean normalization method (see ISO 6974-2:2012, 5.3.2)

The uncertainties of raw mole fractions were first calculated using ISO 6974-2:2012, Formula (3) and are shown in [Table A.7](#). Input data to Formula (3) were obtained as follows:

- The uncertainties of mean responses to the unknown $u(\bar{y}_i)$ were calculated from ISO 6974-2:2012, Formula (6) and are shown in [Table A.6](#).
- The uncertainties of the mean coefficients of the assumed response $u(\overline{b_{1,i}})$ were calculated from ISO 6974-2:2014, Formula (7) and are shown in [Table A.4](#).
- The additional terms in Formula (3) associated with nonlinearity errors are all included because no correction of the raw mole fractions was carried out. The nonlinearity terms are shown in [Table A.2](#).

The uncertainties of mole fractions were calculated from ISO 6974-2:2012, Formula (5) and are shown in [Table A.7](#). Note that terms in x_{oc} and $u(x_{oc})$ are zero in this instance.

A.4.2 Run-by-run normalization method (see ISO 6974-2:2012, 5.3.3)

For each run the uncertainties of raw mole fractions were first calculated using Formula (14) of ISO 6974-2 and are shown in [Table A.8](#). Input data to Formula (3) were obtained as follows:

- The uncertainties of responses to the unknown $u(y_{i,l})$ were calculated as the standard deviation of the responses to the unknown and are shown in [Table A.6](#).
- The uncertainties of the coefficients of the assumed response $u(b_{1,i})$ were calculated from ISO 6974-2:2012, Formula (17) and are shown in [Table A.4](#).
- The additional terms in Formula (14) associated with nonlinearity errors are all included because no correction of the raw mole fractions was carried out. The nonlinearity terms are shown in [Table A.2](#).

For each run the uncertainties of mole fractions were calculated from the numerator of ISO 6974-2:2012, Formula (16) and are shown in [Table A.9](#). Note that terms in x_{oc} and $u(x_{oc})$ are zero in this instance.

The uncertainties of the mean mole fractions were calculated from ISO 6974-2:2012, Formula (16) and are shown in [Table A.10](#). Note that terms in x_{oc} and $u(x_{oc})$ are zero in this instance.

A.5 Comparison of mean normalization and run-by-run approaches

Strictly-speaking, the mole fractions calculated by the two approaches are slightly different and the degree to which they (and their uncertainties) will differ will depend upon the magnitude of the input uncertainties (principally the repeatability of the response of the instrument and the uncertainty in the composition of the WMS). For this example the input uncertainties are small and the differences between the two approaches are negligible.

A.6 Reporting of results

For laboratory analyses in which expanded uncertainty is reported, the expanded uncertainty of mole fraction should be rounded to two significant figures using the normal rules of rounding, as described in ISO/IEC Guide 98-3:2008.^[4] The numerical value of mole fraction should be rounded to the least significant figure in the expanded uncertainty.

A.7 Excel spreadsheet

An Excel spread sheet implementing this example is available on request. It contains a user-defined function that implements Formula (5) and the numerator ISO 6974-2:2012, Formula (16).

Although the spreadsheet will be made available in good faith, there is no implied warranty for its use in contractual, commercial or other applications and no guarantee that it is error-free. However it has been tested by several experts and contains no known error at the time of going to press.

Annex B (informative)

Procedure for Setting Valve timings and Restrictor Setting

B.1 Set all the valves to position 1 [see [Figure 2 a](#)], so that the flow pattern is: column 1 (short boiling point) → column 2 (long boiling-point) → column 3 (porous polymer) → detector. Set the column temperature and carrier gas flow rate through the sensing side of the TCD to the manufacturer's values. In the absence of manufacturer's data, use 95 °C and 28 ml/min, for a system using 2 mm i.d. (1/8 in o.d.) columns.

B.2 Switch valve 3 to position 2 [see [Figure 2 d](#)], so that column 3 is by-passed. Allow the carrier flow to stabilize and then adjust restrictor A so that the flow through the sensing side of the TCD is identical to that measured in [B.1](#).

B.3 Set the TCD reference flow to the value measured in [B.1](#).

B.4 With valve 3 in position 2, inject a sample of natural gas by switching valve 1 to position 2. Record the chromatogram as components elute from column 2. The retention time for n-pentane should be about 2/3rds of the anticipated analysis cycle time. If it is significantly different, return to [B.1](#) and adjust the flow accordingly. Then repeat [B.2](#) to [B.4](#).

B.5 If no switching time is provided by the manufacturer, measure the time from injection to the valley minimum between ethane and propane (T_{FIRSTCUT}). This will be the initial time used for storing the lighter components on column 3.

B.6 Backflushing

B.6.1 The backflush operation must allow all of the latest-eluting C_5 (n- C_5) to be measured by forward elution, and all of the lightest C_6 (2,2, dimethyl-butane) to be backflushed. Use a gas mixture containing n- C_5 and 2,2-di-methyl butane with no other C_6 or heavier components present.

B.6.2 Set an initial timing of 1 min (or as recommended by the manufacturer) after injection at which to switch valve V2 to position 2. Switch V3 to position 2 to isolate column 3. Inject the gas mixture and record the chromatogram. 2,2-di-methyl butane should appear as a backflushed component (C_{6+}) shortly after valve V2 switches from position 1 to position 2, and n- C_5 should appear as a normally eluted peak with a slightly longer retention time than that measured in [B.4](#). (It has to travel through column 1 twice). If no C_{6+} peak is seen, reduce the initial timing and repeat this section.

B.6.3 Continue to inject the gas mixture, increasing the backflush time (V2 to position 2) by 0.05 min on successive injections until the backflushed C_{6+} peak (in fact 2,2-dimethyl butane) starts to diminish in area.

B.6.4 Continue injections of the mixture, now reducing the backflush time by 0.05 min on successive injections. Note the time at which the area of the C_{6+} peak first becomes constant ($T_{\text{BACK HIGH}}$).

B.6.5 Continue injections with further incremental reductions in the backflush time until the size of the n-pentane peak starts to diminish, with a corresponding increase in the size of the C_{6+} peak. Note the latest backflush time at which the areas of both peaks are still constant ($T_{\text{BACK LOW}}$).

B.6.6 Adopt the value of $(T_{\text{BACK LOW}} + T_{\text{BACK HIGH}})/2 = T_{\text{BACK}}$ for backflush of column 1 (V2 → position 2).

B.7 V3 Timing

B.7.1 In the absence of manufacturers data, set the timings of T_{BACK} for backflush ($V2 \rightarrow$ position 2) and $T_{\text{FIRST CUT}}$ for isolation of column 3 ($V3 \rightarrow$ position 2). Switch all valves initially to position 1. Inject a sample of natural gas and, after the elution of n-pentane, switch valve 3 to position 1. Note this time ($T_{V3 \text{ OFF}}$) and use it for these operations for the remainder of this section. Measure the peak area for the propane peak eluted from column 2 (via column 1) and that for the ethane peak eluted from column 3 (also via column 1).

B.7.2 Repeat the analysis, reducing $T_{\text{FIRST CUT}}$ successively in increments of 0.05 min until the ethane peak eluted from column 3 reduces in size.

B.7.3 Continue with repeated analysis, now increasing the $T_{\text{FIRST CUT}}$ in 0.05 min increments until a steady figure is obtained for ethane eluted from column 3. Note the lowest timing value at which this occurs as $T_{\text{FIRST LOW}}$.

B.7.4 Continue this process until the value for propane eluted from column 2 starts to reduce. Note the timing at which this starts to occur as $T_{\text{FIRST HIGH}}$.

B.7.5 Adopt the value of $(T_{\text{FIRST LOW}} + T_{\text{FIRST HIGH}}) / 2 = T_{V3 \text{ ON}}$ as the time for the initial isolation of column 3.

B.8 Final timings

Implement the method with the following timings:

Time	Action	Valve Position	Configuration
0.01 min	Inject	$V1 \rightarrow$ position 2	Figure 2b
T_{BACK}	Backflush	$V2 \rightarrow$ position 2	Figure 2c
$T_{V3 \text{ ON}}$	By-pass column 3	$V3 \rightarrow$ position 2	Figure 2d
$T_{V3 \text{ OFF}}$	Re-connect column 3	$V3 \rightarrow$ position 1	Figure 2e
End of run	Return to start	$V1, V2 \rightarrow$ position 1	Figure 2a

Bibliography

- [1] ISO/IEC Guide 98-3:2008, *Uncertainty of measurement — Part 3: Guide to the expression of uncertainty in measurement (GUM:1995)*
- [2] ISO 6976, *Natural gas — Calculation of calorific values, density, relative density and Wobbe index from composition*
- [3] ISO 7504, *Gas analysis — Vocabulary*
- [4] ISO 10723, *Natural gas — Performance evaluation for analytical systems*

British Standards Institution (BSI)

BSI is the national body responsible for preparing British Standards and other standards-related publications, information and services.

BSI is incorporated by Royal Charter. British Standards and other standardization products are published by BSI Standards Limited.

About us

We bring together business, industry, government, consumers, innovators and others to shape their combined experience and expertise into standards-based solutions.

The knowledge embodied in our standards has been carefully assembled in a dependable format and refined through our open consultation process. Organizations of all sizes and across all sectors choose standards to help them achieve their goals.

Information on standards

We can provide you with the knowledge that your organization needs to succeed. Find out more about British Standards by visiting our website at bsigroup.com/standards or contacting our Customer Services team or Knowledge Centre.

Buying standards

You can buy and download PDF versions of BSI publications, including British and adopted European and international standards, through our website at bsigroup.com/shop, where hard copies can also be purchased.

If you need international and foreign standards from other Standards Development Organizations, hard copies can be ordered from our Customer Services team.

Subscriptions

Our range of subscription services are designed to make using standards easier for you. For further information on our subscription products go to bsigroup.com/subscriptions.

With **British Standards Online (BSOL)** you'll have instant access to over 55,000 British and adopted European and international standards from your desktop. It's available 24/7 and is refreshed daily so you'll always be up to date.

You can keep in touch with standards developments and receive substantial discounts on the purchase price of standards, both in single copy and subscription format, by becoming a **BSI Subscribing Member**.

PLUS is an updating service exclusive to BSI Subscribing Members. You will automatically receive the latest hard copy of your standards when they're revised or replaced.

To find out more about becoming a BSI Subscribing Member and the benefits of membership, please visit bsigroup.com/shop.

With a **Multi-User Network Licence (MUNL)** you are able to host standards publications on your intranet. Licences can cover as few or as many users as you wish. With updates supplied as soon as they're available, you can be sure your documentation is current. For further information, email bsmusales@bsigroup.com.

BSI Group Headquarters

389 Chiswick High Road London W4 4AL UK

Revisions

Our British Standards and other publications are updated by amendment or revision.

We continually improve the quality of our products and services to benefit your business. If you find an inaccuracy or ambiguity within a British Standard or other BSI publication please inform the Knowledge Centre.

Copyright

All the data, software and documentation set out in all British Standards and other BSI publications are the property of and copyrighted by BSI, or some person or entity that owns copyright in the information used (such as the international standardization bodies) and has formally licensed such information to BSI for commercial publication and use. Except as permitted under the Copyright, Designs and Patents Act 1988 no extract may be reproduced, stored in a retrieval system or transmitted in any form or by any means – electronic, photocopying, recording or otherwise – without prior written permission from BSI. Details and advice can be obtained from the Copyright & Licensing Department.

Useful Contacts:

Customer Services

Tel: +44 845 086 9001

Email (orders): orders@bsigroup.com

Email (enquiries): cservices@bsigroup.com

Subscriptions

Tel: +44 845 086 9001

Email: subscriptions@bsigroup.com

Knowledge Centre

Tel: +44 20 8996 7004

Email: knowledgecentre@bsigroup.com

Copyright & Licensing

Tel: +44 20 8996 7070

Email: copyright@bsigroup.com



...making excellence a habit.™