

# Natural gas — Determination of composition with defined uncertainty by gas chromatography —

**Part 4: Determination of nitrogen,  
carbon dioxide and C1 to C5 and C6+  
hydrocarbons for a laboratory and  
on-line measuring system using two  
columns**

The European Standard EN ISO 6974-4:2001 has the status of a  
British Standard

ICS 75.060

## National foreword

This British Standard is the official English language version of EN ISO 6974-4:2001. It is identical with ISO 6974-4:2000.

The UK participation in its preparation was entrusted to Technical Committee PTI/15, Natural gas and gas analysis, which has the responsibility to:

- aid enquirers to understand the text;
- present to the responsible international/European committee any enquiries on the interpretation, or proposals for change, and keep the UK interests informed;
- monitor related international and European developments and promulgate them in the UK.

A list of organizations represented on this committee can be obtained on request to its secretary.

### Cross-references

The British Standards which implement international or European publications referred to in this document may be found in the BSI Standards Catalogue under the section entitled "International Standards Correspondence Index", or by using the "Find" facility of the BSI Standards Electronic Catalogue.

A British Standard does not purport to include all the necessary provisions of a contract. Users of British Standards are responsible for their correct application.

**Compliance with a British Standard does not of itself confer immunity from legal obligations.**

### Summary of pages

This document comprises a front cover, an inside front cover, the EN ISO title page, the EN ISO foreword page, pages ii to v, a blank page, pages 1 to 12, the Annex ZA page and a back cover.

The BSI copyright date displayed in this document indicates when the document was last issued.

This British Standard, having been prepared under the direction of the Sector Committee for Materials and Chemicals, was published under the authority of the Standards Committee and comes into effect on 15 August 2000

### Amendments issued since publication

Amd. No.	Date	Comments
13838	15 July 2002	Implementation of the European Standard

© BSI 15 July 2002

ISBN 0 580 36320 1

ICS 75.060

English version

Natural gas - Determination of composition with defined uncertainty by gas chromatography - Part 4: Determination of nitrogen, carbon dioxide and C1 to C5 and C6+ hydrocarbons for a laboratory and on-line measuring system using two columns (ISO 6974-4:2000)

Gaz naturel - Détermination de la composition avec une incertitude définie par chromatographie en phase gazeuse - Partie 4: Détermination de l'azote, du dioxyde de carbone et des hydrocarbures (C1 à C5 et C6+) pour un laboratoire et un système de mesure en continu employant deux colonnes (ISO 6974-4:2000)

Erdgas - Bestimmung der Zusammensetzung mit definierter Unsicherheit durch Gaschromatographie - Teil 4: Bestimmung von Stickstoff, Kohlenstoffdioxid und C1 bis C5 und C6+ Kohlenwasserstoffen für ein Labor- und On-line-Messsystem mit zwei Säulen (ISO 6974-4:2000)

This European Standard was approved by CEN on 22 June 2001.

CEN members are bound to comply with the CEN/GENELEC Internal Regulations which stipulate the conditions for giving this European Standard the status of a national standard without any alteration. Up-to-date lists and bibliographical references concerning such national standards may be obtained on application to the Management Centre or to any CEN member.

This European Standard exists in three official versions (English, French, German). A version in any other language made by translation under the responsibility of a CEN member into its own language and notified to the Management Centre has the same status as the official versions.

CEN members are the national standards bodies of Austria, Belgium, Czech Republic, Denmark, Finland, France, Germany, Greece, Iceland, Ireland, Italy, Luxembourg, Netherlands, Norway, Portugal, Spain, Sweden, Switzerland and United Kingdom.



EUROPEAN COMMITTEE FOR STANDARDIZATION  
COMITÉ EUROPÉEN DE NORMALISATION  
EUROPÄISCHES KOMITEE FÜR NORMUNG

Management Centre: rue de Stassart, 36 B-1050 Brussels

CORRECTED 2002-03-13

## Foreword

The text of the International Standard from Technical Committee ISO/TC 193 "Natural gas" of the International Organization for Standardization (ISO) has been taken over as a European Standard by CMC.

This European Standard shall be given the status of a national standard, either by publication of an identical text or by endorsement, at the latest by February 2002, and conflicting national standards shall be withdrawn at the latest by February 2002.

According to the CEN/CENELEC Internal Regulations, the national standards organizations of the following countries are bound to implement this European Standard: Austria, Belgium, Czech Republic, Denmark, Finland, France, Germany, Greece, Iceland, Ireland, Italy, Luxembourg, Netherlands, Norway, Portugal, Spain, Sweden, Switzerland and the United Kingdom.

## Endorsement notice

The text of the International Standard ISO 6974-4:2000 has been approved by CEN as a European Standard without any modifications.

NOTE Normative references to International Standards are listed in annex ZA (normative).

INTERNATIONAL  
STANDARD

ISO  
6974-4

First edition  
2000-04-01

---

---

**Natural gas — Determination of  
composition with defined uncertainty by  
gas chromatography —**

Part 4:

**Determination of nitrogen, carbon dioxide  
and C1 to C5 and C6+ hydrocarbons for a  
laboratory and on-line measuring system  
using two columns**

*Gaz naturel — Détermination de la composition avec une incertitude  
définie par chromatographie en phase gazeuse —*

*Partie 4: Détermination de l'azote, du dioxyde de carbone et des  
hydrocarbures (C1 à C5 et C6+) pour un laboratoire et un système de  
mesure en continu employant deux colonnes*



Reference number  
ISO 6974-4:2000(E)



# Contents

Page

Foreword.....	iv
Introduction .....	v
1 Scope .....	1
2 Normative references .....	2
3 Principle.....	2
4 Materials .....	2
5 Apparatus .....	2
6 Procedure .....	4
6.1 Gas chromatographic operating conditions.....	4
6.2 Performance requirements — Peak resolution .....	7
6.3 Determination — Outline of the analysis .....	8
7 Expression of results .....	8
7.1 Calculation.....	8
7.2 Precision and accuracy.....	8
8 Test report .....	8
Annex A (informative) Procedure for setting valve timings and restriction setting.....	9
Annex B (informative) Final time .....	10
Annex C (informative) Typical precision values .....	11
Bibliography .....	12

## Foreword

ISO (the International Organization for Standardization) is a worldwide federation of national standards bodies (ISO member bodies). The work of preparing International Standards is normally carried out through ISO technical committees. Each member body interested in a subject for which a technical committee has been established has the right to be represented on that committee. International organizations, governmental and non-governmental, in liaison with ISO, also take part in the work. ISO collaborates closely with the International Electrotechnical Commission (IEC) on all matters of electrotechnical standardization.

International Standards are drafted in accordance with the rules given in the ISO/IEC Directives, Part 3.

Draft International Standards adopted by the technical committees are circulated to the member bodies for voting. Publication as an International Standard requires approval by at least 75 % of the member bodies casting a vote.

Attention is drawn to the possibility that some of the elements of this part of ISO 6974 may be the subject of patent rights. ISO shall not be held responsible for identifying any or all such patent rights.

International Standard ISO 6974-4 was prepared by Technical Committee ISO/TC 193, *Natural gas*, Subcommittee SC 1, *Analysis of natural gas*.

This part as well as the other five parts of ISO 6974 cancel and replace ISO 6974:1984 which specified only one method.

ISO 6974 consists of the following parts, under the general title *Natural gas — Determination of composition with defined uncertainty by gas chromatography*:

- *Part 1: Guidelines for tailored analysis*
- *Part 2: Measuring-system characteristics and statistics for data treatment*
- *Part 3: Determination of hydrogen, helium, oxygen, nitrogen, carbon dioxide and hydrocarbons up to C<sub>8</sub> using two packed columns*
- *Part 4: Determination of nitrogen, carbon dioxide and C<sub>1</sub> to C<sub>5</sub> and C<sub>6+</sub> hydrocarbons for a laboratory and on-line measuring system using two columns*
- *Part 5: Determination of nitrogen, carbon dioxide and C<sub>1</sub> to C<sub>5</sub> and C<sub>6+</sub> hydrocarbons for a laboratory and on-line process application using three columns*
- *Part 6: Determination of hydrogen, helium, oxygen, nitrogen, carbon dioxide and hydrocarbons up to C<sub>8</sub> using three capillary columns*

Annexes A to C of this part of ISO 6974 are for information only.



## Introduction

This part of ISO 6974 specifies a precise and accurate method for the determination of the composition of natural gas. The compositional data obtained are used for the calculation of the calorific value, the relative density and the Wobbe index. This method requires the use of two columns placed in series in a single-oven gas chromatograph.

The combination of two columns makes backflushing possible. All the constituents including the backflush peak are detected by a thermal conductivity detector (TCD).

This method is derived from ISO 6568, *Natural gas — Simple analysis by gas chromatography*.

This part of ISO 6974 provides one of the methods that may be used for determining the composition of natural gas in accordance with parts 1 and 2 of ISO 6974.



# Natural gas — Determination of composition with defined uncertainty by gas chromatography —

Part 4:

## Determination of nitrogen, carbon dioxide and C1 to C5 and C6+ hydrocarbons for a laboratory and on-line measuring system using two columns

### 1 Scope

This part of ISO 6974 describes a gas chromatographic method for the quantitative determination of natural gas constituents using a two-column system. This method is applicable to determinations made in on-line processes or in the laboratory. It is applicable to the analysis of gases containing constituents within the mole fraction ranges given in Table 1. These ranges do not represent the limits of detection, but the limits within which the stated precision of the method applies. Although one or more components in a sample may not be detected present, the method can still be applicable.

This part of ISO 6974 is only applicable if used in conjunction with parts 1 and 2 of ISO 6974.

Table 1 — Application ranges

Component	Mole fraction range %
Nitrogen	0,001 to 15,0
Carbon dioxide	0,001 to 10
Methane	75 to 100
Ethane	0,001 to 10,0
Propane	0,001 to 3,0
<i>iso</i> -Butane (2-methylpropane)	0,001 to 1,0
<i>n</i> -Butane	0,001 to 1,0
<i>neo</i> -Pentane (2,2-dimethylpropane)	0,001 to 0,5
<i>iso</i> -Pentane (2-methylbutane)	0,001 to 0,5
<i>n</i> -Pentane	0,001 to 0,5
Hexanes + sum of all C <sub>6</sub> and higher hydrocarbons	0,001 to 0,2

NOTE 1 Oxygen is not a normal constituent of natural gas and would not be expected to be present in gas sampled for an on-line instrument. If any oxygen is present as a result of air contamination, it will be measured with the nitrogen. The resulting (nitrogen + oxygen) value will be in error to a small extent because of the slight difference between detector responses for oxygen and nitrogen. Nonetheless, the result for the natural gas/air mixture will be reasonably accurate since neither component contributes to the calorific value.

NOTE 2 The content of helium and argon are assumed to be negligible and unvarying such that helium and argon need not be determined.

## 2 Normative references

The following normative documents contain provisions which, through reference in this text, constitute provisions of this part of ISO 6974. For dated references, subsequent amendments to, or revisions of, any of these publications do not apply. However, parties to agreements based on this part of ISO 6974 are encouraged to investigate the possibility of applying the most recent editions of the normative documents indicated below. For undated references, the latest edition of the normative document referred to applies. Members of ISO and IEC maintain registers of currently valid International Standards.

ISO 6142, *Gas analysis — Preparation of calibration gas mixtures — Gravimetric method.*

ISO 6143, *Gas analysis — Determination of the composition of calibration gas mixtures — Comparison methods.*

ISO 6974-1:2000, *Natural gas — Determination of composition with defined uncertainty by gas chromatography — Part 1: Guidelines for tailored analysis.*

ISO 6974-2:—<sup>1)</sup>, *Natural gas — Determination of composition with defined uncertainty by gas chromatography — Part 2: Measuring-system characteristics and statistics for data treatment.*

ISO 7504:1984, *Gas analysis — Vocabulary.*

## 3 Principle

Determination of nitrogen, carbon dioxide, methane, ethane, propane, butanes and pentanes by gas chromatography using two columns (a short one and a long one) of DC-200 on Chromosorb PAW in a backflush arrangement. The short column retains hydrocarbons heavier than normal pentane which are eluted after backflushing as a C<sub>6+</sub> composite peak. The long column is used for the determination of nitrogen, carbon dioxide, methane up to normal pentane. Detection is carried out by a thermal conductivity detector (TCD). Oxygen, argon, hydrogen and helium are not measured by this method.

## 4 Materials

**4.1 Helium carrier gas**, > 99,99 % pure.

**4.2 Working-reference gas mixtures (WRM)**, the composition of which shall be chosen to be similar to that of the anticipated sample.

Prepare a cylinder of a working-reference gas mixture, by a gravimetric method, in accordance with ISO 6142, and/or certified and validated in accordance with ISO 6143. The working-reference gas mixture shall contain at least nitrogen, carbon dioxide, methane, ethane, propane, *n*-butane, *iso*-butane and possibly *neo*-pentane, *iso*-pentane and *n*-pentane.

## 5 Apparatus

**5.1 Laboratory gas chromatographic (GC) system**, consisting of the following components.

**5.1.1 Gas chromatograph (GC)**, capable of isothermal operation and equipped as follows:

---

1) To be published.

- a) **column oven**, capable of maintaining the temperature of the column temperature to within  $\pm 0,1$  °C over the temperature range from 70 °C to 150 °C;
- b) **valve oven**: capable of being maintained over the temperature range from 70 °C to 150 °C or alternatively having the capacity to fit the valves in the column oven;
- c) **flow regulators**: capable of regulating the carrier gas flow rates.

**5.1.2 Injection device**, consisting of a ten-port sample-injection valve V1 and also used for backflushing C<sub>6+</sub> components (two six-port valves may be used for these duties).

**5.1.3 Metal columns packed with 28 % DC-200 on Chromosorb PAW**, satisfying the performance requirements given in clause 6.2 and consisting of the following packing materials and column dimensions, given as examples, for use with conventional and readily available injection valves and TCD.

Columns shall satisfy the following requirements:

- a) metal tubing:
  - column 1: 0,45 m long, 4,75 mm internal diameter (i.d.) (1/4 in o.d.),
  - column 2: 9 m long, 4,75 mm i.d. (1/4 in o.d.)
- b) packing:
  - stationary phase: 28 % DC-200 (viscosity:  $350 \cdot 10^{-6}$  m<sup>2</sup>/s),
  - support: Chromosorb PAW (45 ASTM mesh to 60 ASTM mesh),
- c) method of packing: any suitable packing method providing uniform column packing and performance characteristics in accordance with 6.2. If purchased individually, as part of a system, or packed individually, their performance shall comply with the specification. When packed individually it is assumed that this will be according to a recognized technique.

NOTE The following packing method is suitable:

Close the column outlet with a sintered disc or glass wool plug. Connect a reservoir containing rather more packing than is needed to fill the column to the inlet and apply a pressure of 0,4 MPa of nitrogen to this reservoir. The flow of packing into the column is assisted by vibration. When the column is full, allow the pressure to decay slowly before disconnecting the reservoir.

- d) conditioning: with freshly prepared columns, more stable baselines can be obtained by conditioning them overnight, with carrier gas flowing, at a temperature of 50 °C higher than that at which they are intended to operate. If this is necessary, but not easily achieved in the gas chromatograph in which the columns are to be used, they can be conditioned after being installed in another unit.

**5.1.4 Thermal conductivity detector (TCD)**, with a time constant no greater than 0,1 s, and internal volume appropriate for the column sizes and flow rate used.

**5.1.5 Controller/peak-measurement system**, having a wide range of sensitivity (0 V to 1 V), capable of measuring peaks on a sloping baseline and able to control automatic operation of the valves according to a sequence selected by the operator.

**5.1.6 Auxiliary equipment**, consisting of valves, tubing and any other accessories, to control the flow of sample gas to the chromatograph and for shutting off this flow for a defined period of time before injection.

## 6 Procedure

### 6.1 Gas chromatographic operating conditions

Set the operating conditions for the apparatus (5.1) as follows.

- a) Oven column: 70 °C to 150 °C, capable of being maintained to within  $\pm 0,1$  °C.
- b) Carrier gas flow rate: with the carrier gas flowing through columns in the order of column 1 toward column 2 [Figure 1 b), configuration 2], set the flow rate so as to obtain an average linear velocity for nitrogen (total column length divided by hold-up time) between 5 cm/s to 10 cm/s (corresponding to a flowrate between 30 ml/min and 60 ml/min).
- c) Valves: if the valves are not fitted in the column oven, set them to a temperature in the range of 70 °C to 150 °C (no less than the column temperature), isothermal and stable to  $\pm 2$  °C.
- d) Detector: TCD
  - temperature setting: between 120 °C and 200 °C;
  - set the bridge current according to manufacturer's instructions.
- e) Controller/peak-measurement system: set up in accordance with the manufacturer's instructions.

**EXAMPLE** An example of the configuration is shown in Figure 1. The measuring system comprises a ten-port sample injection/backflush valve. In configuration 1 [Figure 1 a)], the sample loop is flushed by the sample gas. When the valve is switched in configuration 2 [Figure 1 a)], injection is performed. The valve is returned to configuration 1 after all the *n*-pentane leaves column 1 but before the lowest C<sub>6</sub> isomer leaves column 1 on its way to column 2.

A typical chromatogram is shown in Figure 2.

The gas chromatographic conditions are summarized in Table 2.

The procedure for setting valve timings and restriction setting is described in annexes A and B.

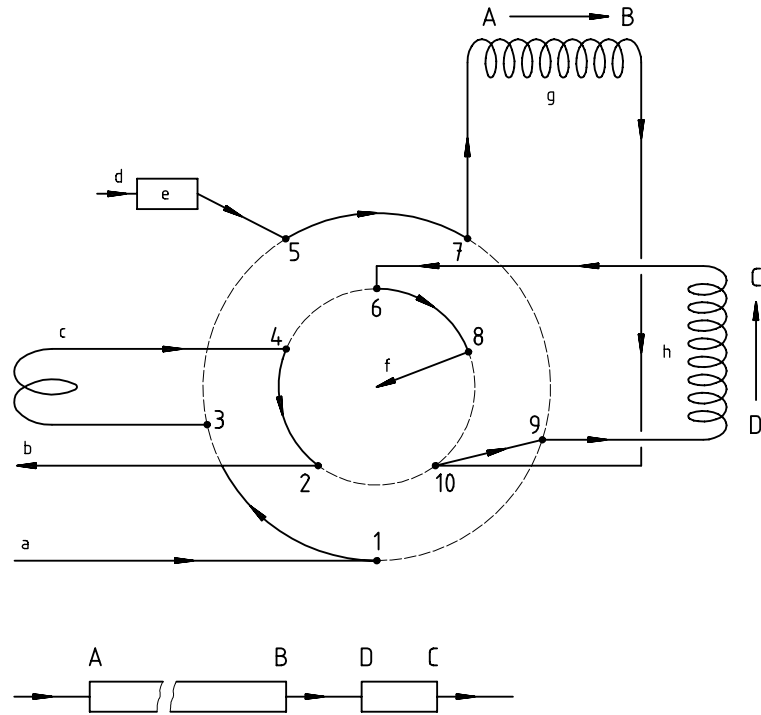

a) Configuration 1

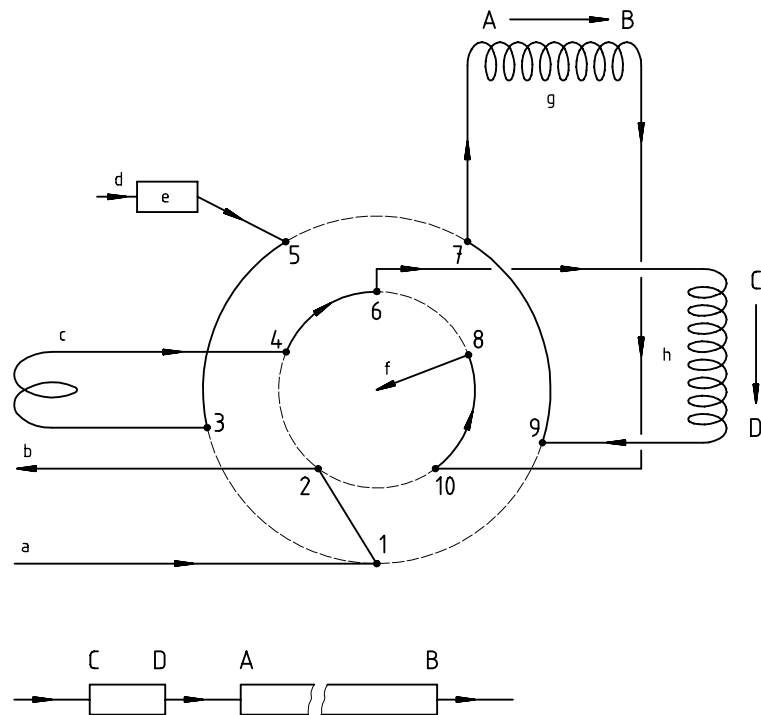

b) Configuration 2

- |   |                    |   |                           |
|---|--------------------|---|---------------------------|
| a | Gas sample         | e | TCD (reference channel)   |
| b | Vent               | f | TCD (analysis channel)    |
| c | Sample loop (1 ml) | g | Column 2 (length: 9 m)    |
| d | Carrier gas        | h | Column 1 (length: 0,45 m) |

Figure 1 — Example of chromatograph set-up

Table 2 — Gas chromatographic conditions

Columns	1	2
Stationary phase:	DC-200	DC-200
Loading:	28 %	28 %
Support:	Chromosorb PAW	Chromosorb PAW
Length:	0,45 m	9 m
Internal diameter, i.d.:	4,75 mm	4,75 mm
ASTM mesh size:	45 to 60	45 to 60
Column tubing:	ss or copper	ss or copper
<b>Carrier gas</b>		
Type:	He	
Flow:	40 ml/min	
<b>Gas chromatograph</b>		
Detector:	TCD	
Integrator:	External	
Injection device:	Valve	
<b>Temperature settings</b>		
Oven:	110 °C	
Detector:	150 °C	
Sample loop:	Oven temperature	
Transfer line	rt	
Sample	rt	
<b>Sample volume:</b>	1 ml	
<b>Analysis time:</b>	20 min.	
Abbreviations:		
ss:	stainless steel	
rt:	room temperature	
TCD:	thermal conductivity detector	
Valve:	injection and backflush device	



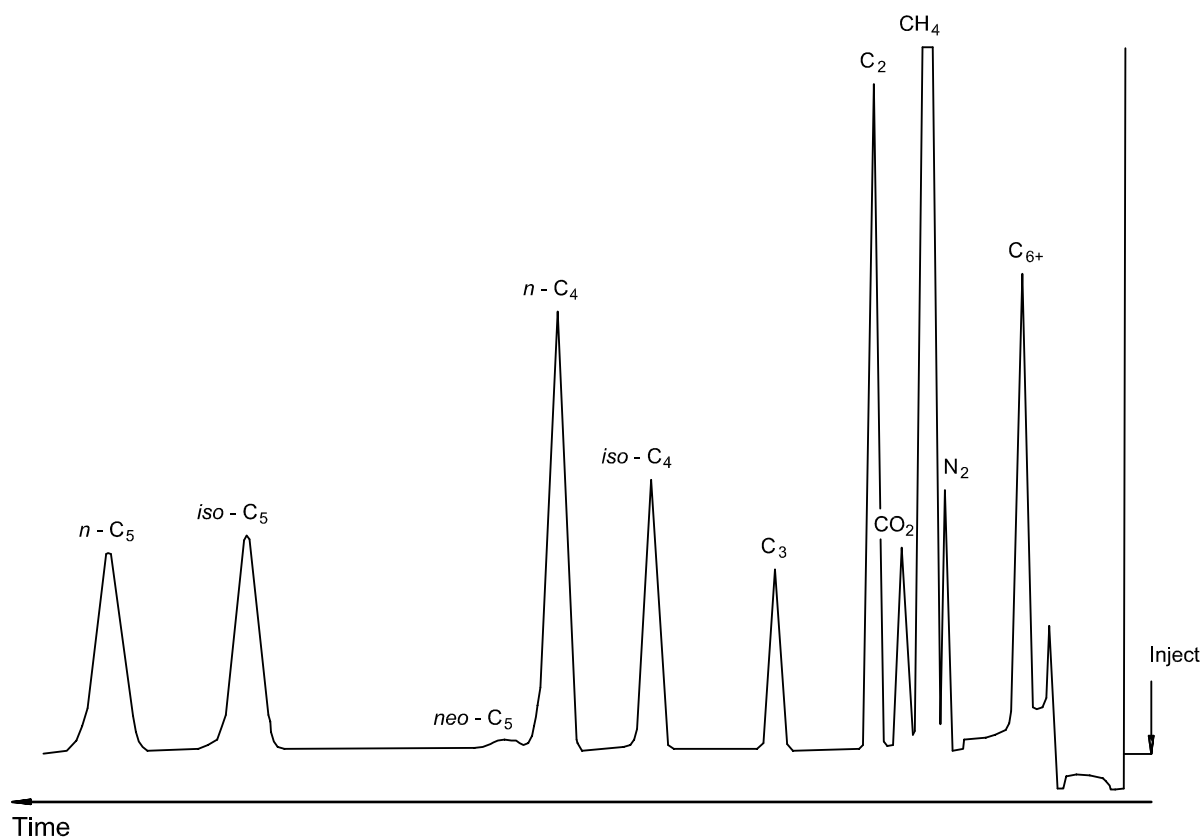

Figure 2 — Example of a typical chromatogram

## 6.2 Performance requirements — Peak resolution

It is important that all components are measured with as less interference from others as possible. Possible interference can be assessed by measuring peak resolution in accordance with 3.3.4.2 of ISO 7504:1984. Although the resolution of all peaks is important, there are no particular pairs of peaks which are critical. However, acceptable resolution of one pair of peaks can ensure acceptable resolution of other peaks.

Furthermore, the resolution required is likely to vary with respect to component uncertainty although it may be deemed acceptable for particular applications. If the procedure is implemented correctly, the values of acceptable peak resolution indicated in Table 3 shall be expected. Higher resolution may require modification of column dimensions, temperature and flowrate, and would likely require longer analysis time.

Each value of resolution shall be tested as part of the normal analytical cycle, not by some alternative procedure designed only to measure these parameters.

Table 3 — Acceptable peak resolution

Component 1	Component 2	Acceptable resolution
<i>iso</i> -Butane	<i>n</i> -Butane	2,2
Nitrogen	Methane	0,7
Carbon dioxide	Ethane	1,6

### 6.3 Determination — Outline of the analysis

The analysis is outlined as follows.

- a) Analyse the working gas mixture and the sample in accordance with clause 11 of ISO 6974-1:2000. An example of a typical chromatogram of the analysis is given in Figure 2.
- b) Measure the content of nitrogen, carbon dioxide, methane, ethane, propane, butanes and pentanes directly by means of determined response curves.
- c) Oxygen, argon, hydrogen and helium are not measured by this analytical method.
- d) No groups shall be determined.
- e) Perform a backflush to analyse higher hydrocarbons as one composite peak ( $C_{6+}$ ) and calibrate it as such.
- f) Use the relative response to determine the content of pentanes when the working-reference gas mixture contains no pentanes. In this case, use *iso*-butane or *n*-butane (propane is optional) as the reference compound.

## 7 Expression of results

### 7.1 Calculation

Refer to ISO 6974-1.

### 7.2 Precision and accuracy

Refer to ISO 6974-2.

See annex C for typical precision values.

## 8 Test report

Report the results in accordance with clause 14 of ISO 6974-1:2000.

## Annex A (informative)

### Procedure for setting valve timings and restriction setting

**A.1** The backflush operation allows *n*-pentane (*n*-C<sub>5</sub>) to be measured by forward elution and all of the lightest C<sub>6</sub> (2,2, dimethyl butane) to be backflushed. Use a gas mixture containing *n*-C<sub>5</sub> and 2,2-dimethyl butane preferably with no other C<sub>6</sub> or heavier component present.

**A.2** Set the initial time to 1,5 min (or as recommended by the manufacturer) after injection at which time the valve returns to configuration 1 (see Figure 1). Inject the gas mixture and record the chromatogram. 2,2-Dimethyl butane should appear as a backflushed component (C<sub>6+</sub>) shortly after the valve returns to configuration 1, and *n*-C<sub>5</sub> should appear as a normally eluted peak. If no C<sub>6+</sub> peak is seen, reduce the initial time setting and repeat this operation.

**A.3** Continue to inject the gas mixture, increasing the backflush time (valve to configuration 1) by 0,05 min for each successive injection until the backflushed C<sub>6+</sub> peak area (in fact 2,2-dimethyl butane) starts to diminish.

**A.4** Continue injecting the mixture, now reducing the backflush time setting by 0,05 min for successive injection. Note the time at which the area of the C<sub>6+</sub> peak first becomes constant (designated as  $t_{\text{back,high}}$ ).

**A.5** Continue injections with further incremental reductions in the backflush time until the size of the *n*-pentane peak starts to diminish, with a corresponding increase in the size of the C<sub>6+</sub> peak. Note the latest backflush time at which the areas of both peaks are still constant (designated as  $t_{\text{back,low}}$ ).

**A.6** Determine the value of  $t_{\text{back}}$  using the following equation

$$t_{\text{back}} = (t_{\text{back,low}} + t_{\text{back,high}}) / 2$$

## Annex B (informative)

### Final time settings

Implement the method given in Table B.1 (see Figure 1).

**Table B.1 — Valve configuration timing**

<b>Time</b>	<b>Action</b>	<b>Valve configuration</b>
0,01 min	Inject	Configuration 2
$t_{\text{back}}$	Backflush	Configuration 1

## Annex C (informative)

### Typical precision values

Typical precision values for repeatability and reproducibility are given in Table C.1.

**Table C.1 — Repeatability and reproducibility of measurement results**

Mole fraction $x$ %	Repeatability		Reproducibility	
	Absolute mole fraction (%)	Relative %	Absolute mole fraction (%)	Relative %
$x < 0,1$	0,001	4,6	0,002	9,2
$0,1 < x < 1$	—	0,5	—	1
$1 < x < 50$	—	0,12	—	0,24
$50 < x < 100$	—	0,006	—	0,012

NOTE These values have been obtained from practical experience and indicate the performance of the method. They cannot be compared as such with precision values mentioned in informative annexes of other parts of ISO 6974 because they result from the quality of the calibration gases and laboratory skills employed.

## Bibliography

- [1] ISO 6976, *Natural gas — Calculation of calorific values, density, relative density and Wobbe index from composition.*
- [2] ISO 10723, *Natural gas — Performance evaluation for on-line analytical systems.*

## Annex ZA (normative)

### Normative references to international publications with their relevant European publications

This European Standard incorporates by dated or undated reference, provisions from other publications. These normative references are cited at the appropriate places in the text and the publications are listed hereafter. For dated references, subsequent amendments to or revisions of any of these publications apply to this European Standard only when incorporated in it by amendment or revision. For undated references the latest edition of the publication referred to applies (including amendments).

NOTE Where an International Publication has been modified by common modifications, indicated by (mod.), the relevant EN/HD applies.

<u>Publication</u>	<u>Year</u>	<u>Title</u>	<u>EN</u>	<u>Year</u>
ISO 6974-1	2000	Natural gas - Determination of composition with defined uncertainty by gas chromatography - Part 1: Guidelines for tailored analysis	EN ISO 6974-1	2001

---

---

## BSI — British Standards Institution

BSI is the independent national body responsible for preparing British Standards. It presents the UK view on standards in Europe and at the international level. It is incorporated by Royal Charter.

### Revisions

British Standards are updated by amendment or revision. Users of British Standards should make sure that they possess the latest amendments or editions.

It is the constant aim of BSI to improve the quality of our products and services. We would be grateful if anyone finding an inaccuracy or ambiguity while using this British Standard would inform the Secretary of the technical committee responsible, the identity of which can be found on the inside front cover.  
Tel: +44 (0)20 8996 9000. Fax: +44 (0)20 8996 7400.

BSI offers members an individual updating service called PLUS which ensures that subscribers automatically receive the latest editions of standards.

### Buying standards

Orders for all BSI, international and foreign standards publications should be addressed to Customer Services. Tel: +44 (0)20 8996 9001.  
Fax: +44 (0)20 8996 7001. Email: [orders@bsi-global.com](mailto:orders@bsi-global.com). Standards are also available from the BSI website at <http://www.bsi-global.com>.

In response to orders for international standards, it is BSI policy to supply the BSI implementation of those that have been published as British Standards, unless otherwise requested.

### Information on standards

BSI provides a wide range of information on national, European and international standards through its Library and its Technical Help to Exporters Service. Various BSI electronic information services are also available which give details on all its products and services. Contact the Information Centre.  
Tel: +44 (0)20 8996 7111. Fax: +44 (0)20 8996 7048. Email: [info@bsi-global.com](mailto:info@bsi-global.com).

Subscribing members of BSI are kept up to date with standards developments and receive substantial discounts on the purchase price of standards. For details of these and other benefits contact Membership Administration.  
Tel: +44 (0)20 8996 7002. Fax: +44 (0)20 8996 7001.  
Email: [membership@bsi-global.com](mailto:membership@bsi-global.com).

Information regarding online access to British Standards via British Standards Online can be found at <http://www.bsi-global.com/bsonline>.

Further information about BSI is available on the BSI website at <http://www.bsi-global.com>.

### Copyright

Copyright subsists in all BSI publications. BSI also holds the copyright, in the UK, of the publications of the international standardization bodies. Except as permitted under the Copyright, Designs and Patents Act 1988 no extract may be reproduced, stored in a retrieval system or transmitted in any form or by any means – electronic, photocopying, recording or otherwise – without prior written permission from BSI.

This does not preclude the free use, in the course of implementing the standard, of necessary details such as symbols, and size, type or grade designations. If these details are to be used for any other purpose than implementation then the prior written permission of BSI must be obtained.

Details and advice can be obtained from the Copyright & Licensing Manager.  
Tel: +44 (0)20 8996 7070. Fax: +44 (0)20 8996 7553.  
Email: [copyright@bsi-global.com](mailto:copyright@bsi-global.com).