

Liquefied petroleum gases — Corrosiveness to copper — Copper strip test

The European Standard EN ISO 6251:1998 has the status of a
British Standard

ICS 75.160.30

National foreword

This British Standard is the official English language version of EN ISO 6251:1998. It is identical with ISO 6251:1996. It supersedes BS EN ISO 6251:1995 which is withdrawn.

The UK participation in its preparation was entrusted to Technical Committee PTI/13, Petroleum testing and terminology, which has the responsibility to:

- aid enquirers to understand the text;
- present to the responsible international/European committee any enquiries on the interpretation, or proposals for change, and keep the UK interests informed;
- monitor related international and European developments and promulgate them in the UK.

A list of organizations represented on this committee can be obtained on request to its secretary.

The Institute of Petroleum publishes and sells all Parts of BS 2000, and all BS EN petroleum test methods that would be Part of BS 2000, both in its annual publication “Standard methods for analysis and testing of petroleum and related products and British Standard 2000 Parts” and individually.

Further information is available from:

**The Institute of Petroleum, 61 New Cavendish Street,
London W1G 7AR.**

Tel: 020 7467 7100. Fax: 020 7255 1472.

Cross-references

The British Standards which implement international or European publications referred to in this document may be found in the *BSI Catalogue* under the section entitled “International Standards Correspondence Index”, or by using the “Search” facility of the *BSI Electronic Catalogue* or of British Standards Online.

This publication does not purport to include all the necessary provisions of a contract. Users are responsible for its correct application.

Compliance with a British Standard does not of itself confer immunity from legal obligations.

Summary of pages

This document comprises a front cover, an inside front cover, pages 1 to 9 and a back cover.

The BSI copyright date displayed in this document indicates when the document was last issued.

Amendments issued since publication

Amd. No.	Date	Comments

This British Standard, having been prepared under the direction of the Materials and Chemicals Sector Policy and Strategy Committee, was published under the authority of the Standards Policy and Strategy Committee on 21 November 2002

© Institute of Petroleum and BSI 21 November 2002



IP 411/99



ISO 6251:1996

BS EN ISO 6251 : 1998
BS 2000 : Part 411 : 1998

EUROPEAN STANDARD

EN ISO 6251

NORME EUROPÉENNE

EUROPÄISCHE NORM

June 1998

ICS 75.160.30

Supersedes EN ISO 6251:1995

Descriptors: see ISO document

English version

Liquefied petroleum gases — Corrosiveness to copper — Copper strip test (ISO 6251:1996)

Gaz de pétrole liquéfiés - Action corrosive sur le
cuivre - Essai à la lame de cuivre (ISO 6251:1996)

Flüssiggase - Korrosionswirkung auf Kupfer -
Kupferstreifenprüfung (ISO 6251:1996)

This European Standard was approved by CEN on 24 May 1998.

CEN members are bound to comply with the CEN/CENELEC Internal Regulations which stipulate the conditions for giving this European Standard the status of a national standard without any alteration. Up-to-date lists and bibliographical references concerning such national standards may be obtained on application to the Central Secretariat or to any CEN member.

This European Standard exists in three official versions (English, French, German). A version in any other language made by translation under the responsibility of a CEN member into its own language and notified to the Central Secretariat has the same status as the official versions.

CEN members are the national standards bodies of Austria, Belgium, Czech Republic, Denmark, Finland, France, Germany, Greece, Iceland, Ireland, Italy, Luxembourg, Netherlands, Norway, Portugal, Spain, Sweden, Switzerland and United Kingdom.



European Committee for Standardization
Comité Européen de Normalisation
Europäisches Komitee für Normung

Central Secretariat: rue de Stassart, 36 B-1050 Brussels

© 1998 CEN

All rights of exploitation in any form and by any means
reserved worldwide for CEN national Members.

Ref. No. EN ISO 6251:1998 E

Foreword

The text of the International Standard from Technical Committee ISO/TC 28 "Petroleum products and lubricants" of the International Organization for Standardization (ISO) has been taken over as an European Standard by Technical Committee CEN/TC 19 "Petroleum products, lubricants and related products", the secretariat of which is held by NNI.

This European Standard supersedes EN ISO 6251:1995.

This European Standard shall be given the status of a national standard, either by publication of an identical text or by endorsement, at the latest by December 1998, and conflicting national standards shall be withdrawn at the latest by December 1998.

According to the CEN/CENELEC Internal Regulations, the national standards organizations of the following countries are bound to implement this European Standard: Austria, Belgium, Czech Republic, Denmark, Finland, France, Germany, Greece, Iceland, Ireland, Italy, Luxembourg, Netherlands, Norway, Portugal, Spain, Sweden, Switzerland and the United Kingdom.

Endorsement notice

The text of the International Standard ISO 6251:1996 has been approved by CEN as a European Standard without any modification.

NOTE: Normative references to International Standards are listed in annex ZA (normative).

Liquefied petroleum gases — Corrosiveness to copper — Copper strip test

WARNING — The use of this International Standard may involve hazardous materials and equipment. This International Standard does not purport to address all of the safety problems associated with its use. It is the responsibility of the user of this International Standard to establish appropriate safety and health practices and determine the applicability of regulatory limitations prior to use.

1 Scope

This International Standard describes a method for the determination of the corrosiveness to copper of liquefied petroleum gases.

NOTE For an equivalent copper strip test applicable to less volatile petroleum products, see ISO 2160.

2 Normative references

The following standards contain provisions which, through reference in this text, constitute provisions of this International Standard. At the time of publication, the editions indicated were valid. All standards are subject to revision, and parties to agreements based on this International Standard are encouraged to investigate the possibility of applying the most recent edition of the standards indicated below. Members of IEC and ISO maintain registers of currently valid International Standards.

ISO 2160: 1985, *Petroleum products — Corrosiveness to copper — Copper strip test*.

ISO 3696: 1987, *Water for analytical laboratory use — Specification and test methods*.

3 Definition

For the purposes of this International Standard, the following definition applies.

3.1 liquefied petroleum gas (LPG): Hydrocarbon gas that can be stored and/or handled in the liquid phase under moderate conditions of pressure and at ambient temperature. It consists essentially of C₃ and C₄ alkanes or alkenes, or a

mixture of these, contains generally less than 5 % by liquid volume of material of higher carbon number, and having a gauge vapour pressure not exceeding approximately 1 600 kPa at 40 °C.

4 Principle

A polished copper strip is immersed for 1 h at a temperature of 40 °C in 100 ml of water-saturated LPG sample contained in a test cylinder at a suitable working pressure. At the end of this period, the copper strip is removed and the corrosiveness to copper of the LPG sample is rated as one of four classifications given in table 1 by comparison with a copper corrosion standard plaque.

5 Reagents and materials

5.1 Wash solvent, analytical grade acetone free from sulfur, or 2,2,4-trimethylpentane, 99 % minimum purity.

5.2 Water, conforming to grade 3 of ISO 3696.

5.3 Copper strip, 75 mm ± 5 mm long, 12,5 mm ± 2,5 mm wide, and 1,5 to 3,0 mm thick, conforming to the specification for copper given in ISO 2160 and having a hole of 3 mm diameter drilled approximately 3 mm from one end and centred across the width of the strip.

5.4 Polishing materials, including silicon carbide grit paper of various degrees of fineness, one of which is 65 µm paper or cloth; also a supply of 105 µm silicon carbide powder and pharmaceutical grade absorbent cotton (cotton wool).

Table 1 — Copper strip corrosion classifications

Classification	Designation	Description ¹⁾
Freshly polished copper strip	Untarnished	2)
1	Slight tarnish	Light orange, almost the same as a freshly polished strip Dark orange
2	Moderate tarnish	Claret red Lavender Multicoloured with lavender blue and/or silver overlaid on claret red Silvery Brassy or gold
3	Dark tarnish	Magenta overcast on brassy strip Multicoloured with red and green showing (peacock), but no grey
4	Corrosion	Transparent black, dark grey or brown with peacock green barely showing Graphite or lustreless black Glossy or jet black

1) The copper corrosion standard is comprised of strips characteristic of these descriptions.

2) The freshly polished strip is included in the series only as an indication of the appearance of a properly polished strip before a test run; it is not possible to duplicate this appearance after a test even with a completely non-corrosive LPG sample.

5.5 Copper corrosion standards¹⁾

The care and inspection for stability of such plaques shall be carried out in accordance with ISO 2160.

6 Apparatus

6.1 Corrosion test cylinder (see figure 1), capable of withstanding a hydrostatic pressure test of 7,0 MPa, and leaktight when filled with gas at a pressure of 3,5 MPa and immersed in the water bath (6.2). It shall consist of the following items:

6.1.1 Stainless steel test cylinder, of the form and dimensions shown in figure 1 and tapped at the lower end to take a suitable type of 6 mm needle-valve, top-end threaded for attachment with top closure.

NOTE A needle-valve with V-cone stem tip design has been found suitable.

6.1.2 Top closure, of stainless steel, with a chloroprene rubber O-ring on the internal surface and with threaded coupling to secure to the stainless steel test cylinder.

The closure shall be tapped to take a suitable type of 6 mm needle-valve (see note in 6.1.1) and to

carry a stainless steel dip-tube, at the lower end of which there shall be a hook from which the copper strip is hung.

6.1.3 Aluminium flexible connecting hose, with swivel connections adapted to a 6 mm diameter pipe.

6.2 Water-bath, capable of being maintained at $40\text{ °C} \pm 1\text{ °C}$.

The bath shall be fitted with suitable supports to hold the test cylinder (6.1) in an upright position and be deep enough so that the entire cylinder and valves will be covered during the test.

6.3 Thermometer, of the total immersion type, having a range of 0 °C to 50 °C , subdivided at intervals not greater than $0,2\text{ °C}$, and having a scale error not greater than $0,15\text{ °C}$.

NOTE An ASTM 12 C/IP 64 C thermometer has been found suitable.

6.4 Strip-polishing vice, for holding the copper strip firmly without marring the edge during polishing.

Any convenient type of vice may be used, provided that the strip is held tightly and that the surface being polished is supported above the surface of the holder.

1) The copper strip corrosion standard is available commercially. Details may be obtained from the Secretariat of ISO/TC 28.

Dimensions in millimetres

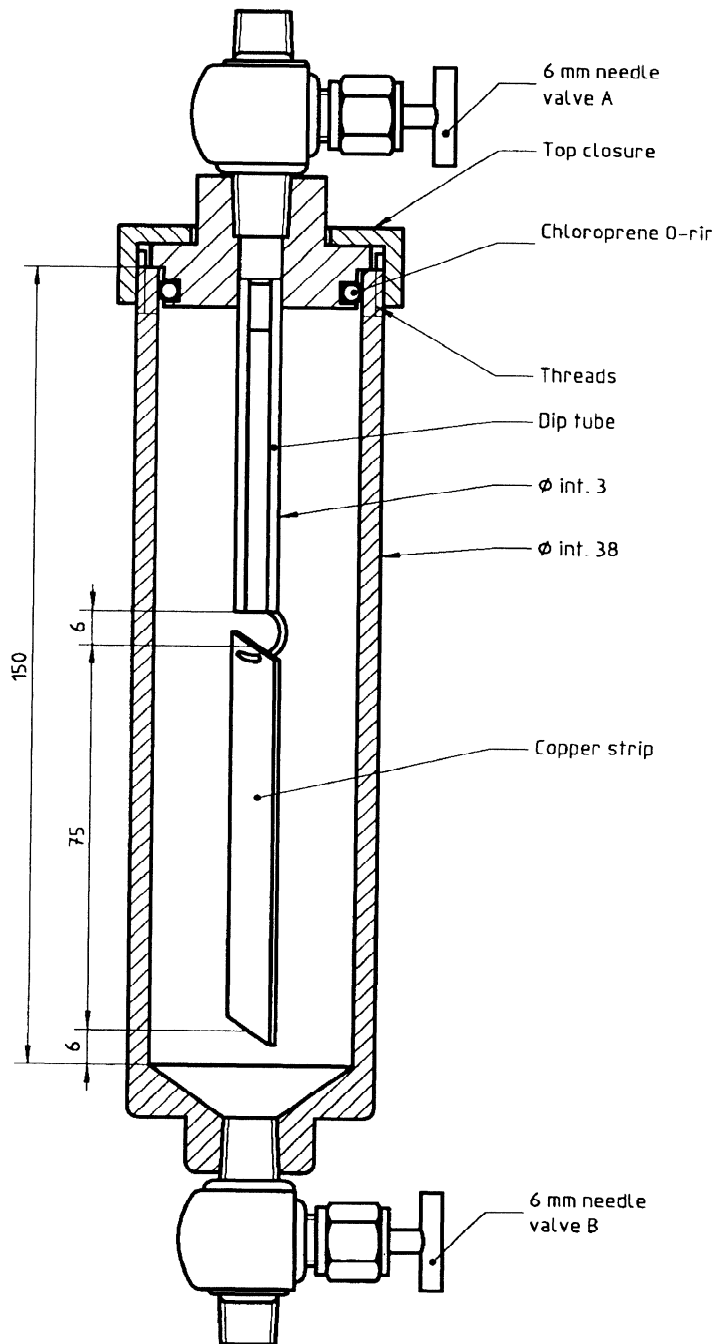

Material of test cylinder, dip tube, needle-valves: Stainless steel

Figure 1 – Copper strip corrosion test cylinder

7 Preparation of strips

7.1 Surface preparation

Remove all surface blemishes from all six faces of the copper strip (5.3) with silicon carbide grit paper (5.4) of such degrees of fineness as are needed to accomplish the desired results efficiently. Finish with 65 μm silicon carbide paper or cloth, removing all marks that may have been made by other grades of paper used previously. Immerse the strip in the wash solvent (5.1), from which it may be withdrawn immediately for final polishing or in which it may be stored for future use.

As a practical manual polishing procedure, place a sheet of the paper on a flat surface, moisten it with the wash solvent and rub the strip against the paper with a rotary motion, protecting the strip from contact with the fingers with an ashless filter paper. Alternatively, the strip may be prepared by use of motor-driven machines using appropriate grades of dry paper or cloth.

7.2 Final polishing

Remove the strip from the wash solvent. Holding it in the fingers protected with ashless filter paper, polish first the ends and then each face with 105- μm silicon carbide powder picked up from a clean glass plate with a pad of absorbent cotton moistened with several drops of wash solvent. Wipe vigorously with fresh pads of absorbent cotton and subsequently handle only with stainless steel forceps; do not touch with the fingers. Clamp in the vice (6.4) and polish the main surfaces with silicon carbide powder on absorbent cotton. Rub in the direction of the long axis of the strip, carrying the stroke beyond the end of the strip before reversing the direction. Clean all metal dust from the strip by rubbing vigorously with clean pads of absorbent cotton until a fresh pad remains unsoiled. When the strip is clean, immediately attach it to the dip-tube (see 6.1.2) and immerse it in the prepared test cylinder (6.1.1).

NOTE It is important to polish the whole surface of the strip uniformly to obtain a uniformly stained strip. If the edges show wear (surface elliptical), they are likely to show more corrosion than the centre. The use of a vice facilitates uniform polishing.

8 Procedure

CAUTION Provide a safe means for disposal of liquid and escaping vapour during the entire operation. Follow the safety precautions given in annex A.

8.1 With valve B (see figure 1) open, place approximately 1 ml of the water (5.2) into the clean test cylinder (6.1) and swirl to moisten the walls; allow the remaining water to drain from the test cylinder. Insert the freshly polished copper strip suspended from the hook on the dip-tube, making sure that the bottom of the strip is at least 6 mm from the bottom of the test cylinder when assembled. After assembly of the apparatus, close both valves A and B.

8.2 Holding the test cylinder upright so as not to wet the copper strip with water, attach the sample source to the test cylinder valve A by means of a short length of the flexible hose (6.1.3), which has been purged with the LPG sample. Admit some sample to the test cylinder by opening the valve at the sample source and then valve A.

8.3 Close valve A without disconnecting the test cylinder from the sample source. Invert the test cylinder and open valve B to purge the air from the test cylinder. Return the test cylinder to the upright position and drain any residual liquid through the open valve B. Close valve B with the test cylinder now in its upright position, open valve A and fill the test cylinder with the sample. When the test cylinder is full, close valve A and the valve at the sample source. Disconnect the flexible hose.

8.4 As soon as the flexible hose is disconnected, and with the cylinder in its upright position, open valve A slightly so that all liquid above the end of the dip-tube will be removed from the test cylinder. When vapour first emerges from valve A, close valve A.

8.5 Immediately after regulation of the liquid level as described in 8.4, immerse the test cylinder in the water bath (6.2) maintained at $40\text{ }^{\circ}\text{C} \pm 1\text{ }^{\circ}\text{C}$. Allow the test cylinder to remain in the bath for $1\text{ h} \pm 5\text{ min}$.

8.6 At the end of the test period, remove the test cylinder from the bath and, holding the test cylinder in a vertical position, open the bottom

valve and empty into a suitable disposal unit until all of the liquid and most of the vapour is discharged.

8.7 When only a slight pressure remains in the test cylinder, disassemble the cylinder immediately and at once compare the copper strip which has been exposed to the liquefied petroleum gases with the copper corrosion standard plaque (5.5). Hold both the test strip and the plaque in such a manner that light reflected from them at an angle of approximately 45° will be observed.

NOTE In handling the test strip during the inspection and comparison, the danger of marking or staining can be avoided if it is inserted in a flat test tube which is then stoppered with absorbent cotton.

8.8 If the copper strip shows a corrosion of class 3 or class 4 as shown in table 1, the interior of the test cylinder shall be polished with steel wool and washed with the wash solvent soon after use so as to be clean for another test.

9 Expression of results

9.1 The corrosiveness of the LPG sample should be expressed as class 1, class 2, class 3 or class 4, as shown in table 1, depending upon which colour strip of the standard plaque the copper strip matches. Interpret the colorations as

described in ISO 2160 or from information given on the reverse side of the standard plaque.

9.2 Report the test duration and temperature in the form (xh/y °C).

9.3 The added water frequently causes isolated brown spots on the copper strip. Either disregard the presence of these spots or repeat the test.

10 Test report

The test report shall contain at least the following information:

- a) a reference to this International Standard or to a corresponding national standard;
- b) the type and identification of the product tested;
- c) the result of the test, expressed in accordance with clause 9;
- d) any deviation, by agreement or otherwise, from the procedure specified;
- e) the date of the test.

Annex A (normative)

Safety precautions

A.1 General precautions

A.1.1 Safety precautions regarding the practice of handling liquefied petroleum gas in the laboratory shall be meticulously observed during the determination specified in this International Standard.

A.1.2 Liquefied petroleum gas can cause serious cold burns; care shall be taken, therefore, to prevent the liquid from coming into contact with the skin; when handling liquefied petroleum gas, protective goggles and gloves shall be worn.

A.1.3 Discharge of liquefied petroleum gas can give rise to static electricity, and it is essential to connect apparatus to earth (ground) before discharging.

A.1.4 Take care to avoid breathing petroleum vapours during the application of test methods concerning liquefied petroleum gas.

A.1.5 Care shall be taken that it is safe to discharge liquefied petroleum gas in the vicinity during ullaging operations.

A.2 Precautions specific to this International Standard

When working with 2,2,4-trimethylpentane:

- keep away from heat sparks, and open flame;
- keep container closed;
- use with adequate ventilation;
- avoid buildup of vapours and eliminate all sources of ignition, especially non-explosion-proof electrical apparatus and heaters;
- avoid prolonged breathing of vapour or spray mist;
- avoid prolonged or repeated skin contact.

Annex ZA (normative)

Normative references to international publications with their relevant European publications

This European Standard incorporates by dated or undated reference, provisions from other publications. These normative references are cited at the appropriate places in the text and the publications are listed hereafter. For dated references, subsequent amendments to or revisions of any of these publications apply to this European Standard only when incorporated in it by amendment or revision. For undated references the latest edition of the publication referred to applies.

<u>Publication</u>	<u>Year</u>	<u>Title</u>	<u>EN</u>	<u>Year</u>
ISO 2160	1985	Petroleum products — Corrosiveness to copper — Copper strip test	EN ISO 2160	1995
ISO 3696	1987	Water for analytical laboratory use — Specification and test methods	EN ISO 3696	1995

The Institute of Petroleum

61. New Cavendish Street
London
W1G 7AR

Tel: +44 (0)20 7467 7100
Fax: +44 (0)20 7255 1472
www.petroleum.co.uk

Buying Parts of BS 2000

Orders for BS 2000 publications should be addressed to:

The Library at the Institute of Petroleum

British Standards Institution — Customer services
389 Chiswick High Road
London
W4 4AL

Tel: +44 (0)20 8996 9001
Fax: +44 (0)20 8996 7001
www.bsi-global.com

Order hard copy standards securely via:
www.bsi-global.com/bsonline

Copyright

Copyright subsists in all BS 2000 publications. No part of this publication may be reproduced in any form without the prior permission in writing of BSI and the IP. Enquiries about copyright should be made to the Secretary of PTI/13 at the IP.



THE INSTITUTE
OF PETROLEUM