

Gas analysis — Preparation of calibration gas mixtures using dynamic volumetric methods

Part 7: Thermal mass-flow controllers

ICS 71.040.40

National foreword

This British Standard is the UK implementation of EN ISO 6145-7:2010. It is identical to ISO 6145-7:2009. It supersedes BS ISO 6145-7:2009 which is withdrawn.

The UK participation in its preparation was entrusted to Technical Committee PTI/15, Natural gas and gas analysis.

A list of organizations represented on this committee can be obtained on request to its secretary.

This publication does not purport to include all the necessary provisions of a contract. Users are responsible for its correct application.

Compliance with a British Standard cannot confer immunity from legal obligations.

This British Standard was published under the authority of the Standards Policy and Strategy Committee on 30 April 2009

© BSI 2011

Amendments/corrigenda issued since publication

Date	Comments
30 June 2011	This corrigendum renumbers BS ISO 6145-7:2009 as BS EN ISO 6145-7:2010

ISBN 978 0 580 72205 9

EUROPEAN STANDARD

EN ISO 6145-7

NORME EUROPÉENNE

EUROPÄISCHE NORM

December 2010

ICS 71.040.40

English Version

Gas analysis - Preparation of calibration gas mixtures using dynamic volumetric methods - Part 7: Thermal mass-flow controllers (ISO 6145-7:2009)

Analyse des gaz - Préparation des mélanges de gaz pour étalonnage à l'aide de méthodes volumétriques dynamiques - Partie 7: Régulateurs thermiques de débit massique (ISO 6145-7:2009)

Gasanalyse - Herstellung von Kalibriergasgemischen mit Hilfe von dynamisch-volumetrischen Verfahren - Teil 7: Thermische Massendurchflussregler (ISO 6145-7:2009)

This European Standard was approved by CEN on 11 December 2010.

CEN members are bound to comply with the CEN/CENELEC Internal Regulations which stipulate the conditions for giving this European Standard the status of a national standard without any alteration. Up-to-date lists and bibliographical references concerning such national standards may be obtained on application to the CEN-CENELEC Management Centre or to any CEN member.

This European Standard exists in three official versions (English, French, German). A version in any other language made by translation under the responsibility of a CEN member into its own language and notified to the CEN-CENELEC Management Centre has the same status as the official versions.

CEN members are the national standards bodies of Austria, Belgium, Bulgaria, Croatia, Cyprus, Czech Republic, Denmark, Estonia, Finland, France, Germany, Greece, Hungary, Iceland, Ireland, Italy, Latvia, Lithuania, Luxembourg, Malta, Netherlands, Norway, Poland, Portugal, Romania, Slovakia, Slovenia, Spain, Sweden, Switzerland and United Kingdom.



EUROPEAN COMMITTEE FOR STANDARDIZATION
COMITÉ EUROPÉEN DE NORMALISATION
EUROPÄISCHES KOMITEE FÜR NORMUNG

Management Centre: Avenue Marnix 17, B-1000 Brussels

Foreword

The text of ISO 6145-7:2009 has been prepared by Technical Committee ISO/TC 158 “Analysis of gases” of the International Organization for Standardization (ISO) and has been taken over as EN ISO 6145-7:2010.

This European Standard shall be given the status of a national standard, either by publication of an identical text or by endorsement, at the latest by June 2011, and conflicting national standards shall be withdrawn at the latest by June 2011.

Attention is drawn to the possibility that some of the elements of this document may be the subject of patent rights. CEN [and/or CENELEC] shall not be held responsible for identifying any or all such patent rights.

According to the CEN/CENELEC Internal Regulations, the national standards organizations of the following countries are bound to implement this European Standard: Austria, Belgium, Bulgaria, Croatia, Cyprus, Czech Republic, Denmark, Estonia, Finland, France, Germany, Greece, Hungary, Iceland, Ireland, Italy, Latvia, Lithuania, Luxembourg, Malta, Netherlands, Norway, Poland, Portugal, Romania, Slovakia, Slovenia, Spain, Sweden, Switzerland and the United Kingdom.

Endorsement notice

The text of ISO 6145-7:2009 has been approved by CEN as a EN ISO 6145-7:2010 without any modification.

Contents

Page

Foreword.....	iv
1 Scope	1
2 Normative references	1
3 Terms and definitions.....	1
4 Principle.....	2
5 Set-up	2
5.1 General.....	2
5.2 Thermal mass-flow controller using a constant current supply.....	2
5.3 Thermal mass-flow controller under constant temperature control	3
6 Preparation of gas mixtures	4
6.1 Description of the experimental procedure	4
6.2 Area of validity	6
6.3 Operating conditions.....	6
7 Calculations.....	7
7.1 Volume fraction.....	7
7.2 Sources of uncertainty	7
7.3 Uncertainty of measurement	8
Annex A (informative) Pre-mixed gases for preparation of mixtures of high dilution	9
Annex B (informative) Practical hints.....	10
Annex C (informative) Calculation of uncertainties.....	12
Bibliography	15

Foreword

ISO (the International Organization for Standardization) is a worldwide federation of national standards bodies (ISO member bodies). The work of preparing International Standards is normally carried out through ISO technical committees. Each member body interested in a subject for which a technical committee has been established has the right to be represented on that committee. International organizations, governmental and non-governmental, in liaison with ISO, also take part in the work. ISO collaborates closely with the International Electrotechnical Commission (IEC) on all matters of electrotechnical standardization.

International Standards are drafted in accordance with the rules given in the ISO/IEC Directives, Part 2.

The main task of technical committees is to prepare International Standards. Draft International Standards adopted by the technical committees are circulated to the member bodies for voting. Publication as an International Standard requires approval by at least 75 % of the member bodies casting a vote.

Attention is drawn to the possibility that some of the elements of this document may be the subject of patent rights. ISO shall not be held responsible for identifying any or all such patent rights.

ISO 6145-7 was prepared by Technical Committee ISO/TC 158, *Analysis of gases*.

This second edition cancels and replaces the first edition (ISO 6145-7:2001). In preparation of the first edition, it was assumed that each thermal mass-flow controller (TMC) would be configured for use at its optimum performance, and the uncertainty in the method was estimated on that basis. In this edition, therefore, extra precautionary text has been added to make it clear that the method shall not be employed, for example, to make a 10:1 binary mixture by using two thermal mass-flow controllers of identical range with one operated at its maximum, say, of 1 000 ml/min and the other at 100 ml/min. In the first edition, this necessary provision was only stated briefly in an informative annex; it has now been expanded and stated more explicitly in a normative part. Another major update is separation of the original Clause 3 into two clauses, one of which (Clause 4) defines the principle while the other (Clause 5) presents additional explanation to the user. The latter of these clauses now includes the necessary requirements. By introducing two new and relevant bibliographic references, the understanding of Annex B has been improved. Finally, some typing errors have been corrected.

ISO 6145 consists of the following parts, under the general title *Gas analysis — Preparation of calibration gas mixtures using dynamic volumetric methods*:

- *Part 1: Methods of calibration*
- *Part 2: Volumetric pumps*
- *Part 4: Continuous syringe injection method*
- *Part 5: Capillary calibration devices*
- *Part 6: Critical orifices*
- *Part 7: Thermal mass-flow controllers*
- *Part 8: Diffusion method*
- *Part 9: Saturation method*
- *Part 10: Permeation method*
- *Part 11: Electrochemical generation*

ISO 6145-3, entitled *Periodic injections into a flowing gas stream*, has been withdrawn.

Gas analysis — Preparation of calibration gas mixtures using dynamic volumetric methods —

Part 7: Thermal mass-flow controllers

1 Scope

This part of ISO 6145 is one of a series of International Standards dealing with dynamic volumetric methods used for the preparation of calibration gas mixtures. This part specifies a method for continuous production of calibration gas mixtures, containing two or more components, from pure gases or other gas mixtures by use of commercially available thermal mass-flow controllers.

If this method is employed for the preparation of calibration gas mixtures, the optimum performance is as follows: the relative expanded uncertainty of measurement, U , obtained by multiplying the combined standard uncertainty by a coverage factor $k = 2$, is not greater than 2 %.

If pre-mixed gases are used instead of pure gases, mole fractions below 10^{-6} can be obtained. The measurement of mass flow is not absolute and the flow controller requires independent calibration.

The merits of the method are that a large quantity of the gas mixture can be prepared on a continuous basis and that multicomponent mixtures can be prepared as readily as binary mixtures if the appropriate number of thermal mass-flow controllers is utilized.

NOTE Gas-blending systems based upon thermal mass-flow controllers, some including the facility of computerization and automatic control, are commercially available.

2 Normative references

The following referenced documents are indispensable for the application of this document. For dated references, only the edition cited applies. For undated references, the latest edition of the referenced document (including any amendments) applies.

ISO 6143, *Gas analysis — Comparison methods for determining and checking the composition of calibration gas mixtures*

ISO 6145-1:2003, *Gas analysis — Preparation of calibration gas mixtures using dynamic volumetric methods — Part 1: Methods of calibration*

ISO 7504, *Gas analysis — Vocabulary*

3 Terms and definitions

For the purposes of this document, the terms and definitions given in ISO 7504 apply.

4 Principle

Continuous production of calibration gas mixtures, containing two or more components, from pure gases or other gas mixtures by the use of commercially available thermal mass-flow controllers is described. By adjusting the set-points on the flow controllers to pre-determined values, it is possible to change the composition of the gas mixture rapidly and in a continuously variable manner. By selecting appropriate combinations of thermal mass-flow controllers and with the use of pure gases, the volume fraction of the component of interest in the complementary gas can be varied by a factor of 1 000.

5 Set-up

5.1 General

To prepare the gas mixture, each gaseous component is passed at a known, controlled flow rate, and at constant pressure, from a calibrated thermal mass-flow controller. Use accurate flowmeters in measuring the relevant flows in order to reach an acceptable measure of uncertainty regardless of the setting of the mass-flow controller (see also ISO 6145-1:2003, Table 1).

A thermal mass-flow controller consists of a measuring unit for mass flow and a proportioning valve which is controlled by an electronic unit (see also References [1] and [2]).

5.2 Thermal mass-flow controller using a constant current supply

The flowing gas is passed through a heater connected to a constant current supply and the temperature is sensed upstream and downstream from the heater.

Figure 1 shows the principle of a thermal mass-flow controller: heater, temperature sensors and associated circuitry. The two temperature sensors, one upstream and one downstream from the heater form two arms of a Wheatstone bridge circuit, which is balanced to give a zero reading when there is no gas flow. When there is a gas flow through the system, a temperature difference, ΔT , is established between the two sensors such that the heat flux, Φ , is given by:

$$\Phi = c_p \Delta T q_m \quad (1)$$

where

c_p is the heat capacity per unit mass, or molar heat capacity, of the gas at constant pressure;

q_m is the mass flow rate.

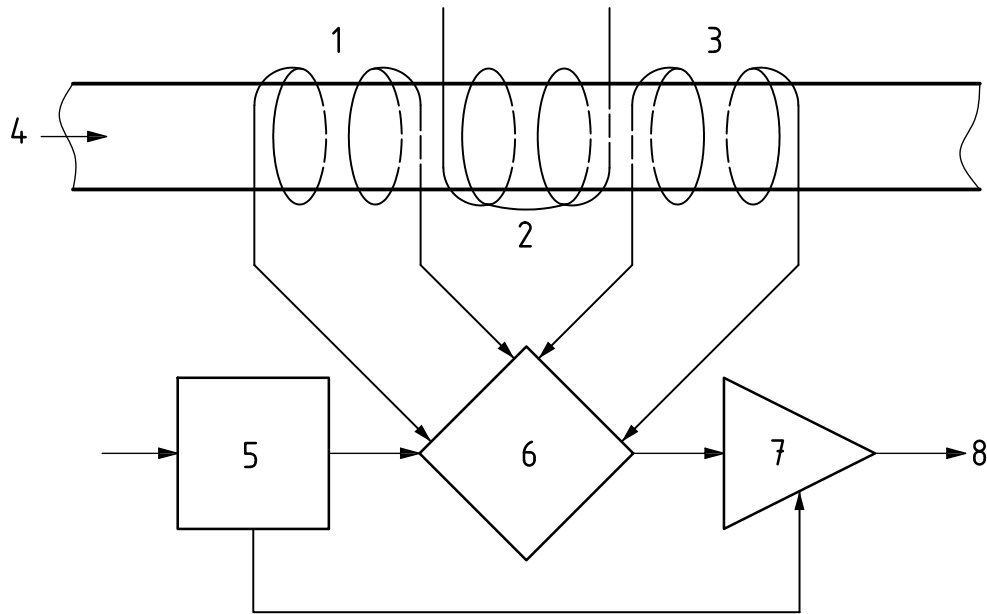

Key

- 1 temperature sensor 1
- 2 temperature sensor 2
- 3 heater
- 4 gas supply
- 5 current supply
- 6 Wheatstone bridge
- 7 differential amplifier
- 8 signal readout

Figure 1 — Principle of a thermal mass-flow controller with constant current supply

The difference in temperature between sensors results in a potential difference across the Wheatstone bridge circuit and thus a signal. The signal is compared with an adjustable reference voltage in a differential amplifier. The resulting output signal is in turn used for operating a control valve to regulate the flow of gas.

5.3 Thermal mass-flow controller under constant temperature control

In this system (see Figure 2), the gas passes through three heaters in sequence, each of which is connected to an arm of a self-regulating Wheatstone bridge. Instead of the difference in temperature being measured, the input to each heater is such that the temperature distribution along the flow path is maintained uniform. The Wheatstone bridge current is proportional to the heat loss and therefore proportional also to the mass flow of the gas. The output signal is again used to operate a solenoid valve to control the mass flow rate.

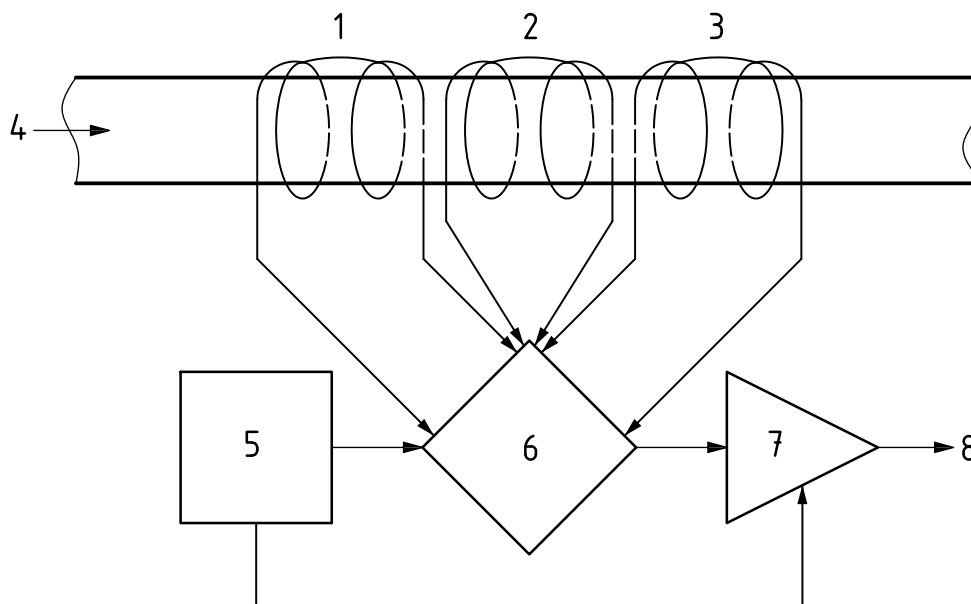

Key

- 1 heater 1
- 2 heater 2
- 3 heater 3
- 4 gas supply
- 5 current supply
- 6 Wheatstone bridge
- 7 differential amplifier
- 8 signal readout

Figure 2 — Thermal mass-flow controller under constant temperature control

In the preparation of multicomponent mixtures, it is in general necessary to use one mass-flow controller for each component. Dual-channel controllers are available and may be used in the preparation of binary mixtures or, for example, in the preparation of mixtures of a given gas in air.

6 Preparation of gas mixtures

6.1 Description of the experimental procedure

A schematic diagram of the arrangement used for the preparation of binary mixtures is shown in Figure 3.

The pressure and temperature at the time of the calibration shall be recorded.

Depending on the gases to be mixed and the fact that they are not ideal, the volume fraction can be somewhat influenced by the ambient pressure and temperature. The pressure and temperature at the time of calibration of the analyser should be as near as possible to those prevalent at the time the thermal mass-flow controllers were checked by the comparison method given in ISO 6143 (see 7.3).

Concentrations of calibration gas mixtures are normally expressed as volume fractions but manufacturers' accuracy specifications for thermal mass-flow controllers are expressed in terms of percentage of the full scale of the instrument. The relative expanded uncertainty of 2 %, which is quoted in the scope of this part of ISO 6145, is 2 % of the volume fraction of the calibration component of the mixture. This value assumes optimum use of each thermal mass-flow controller in the system, which means that each is operated at, or

very near to, its maximum flow rate. Thus, if a thermal mass-flow controller is operated at 10 % of full scale, the expanded uncertainty expressed as a percentage of maximum flow (as distinct from relative expanded uncertainty) can be $\pm 1\%$, but, if it is expressed instead in terms of a percentage of the actual flow rate, the expanded uncertainty becomes 10 %.

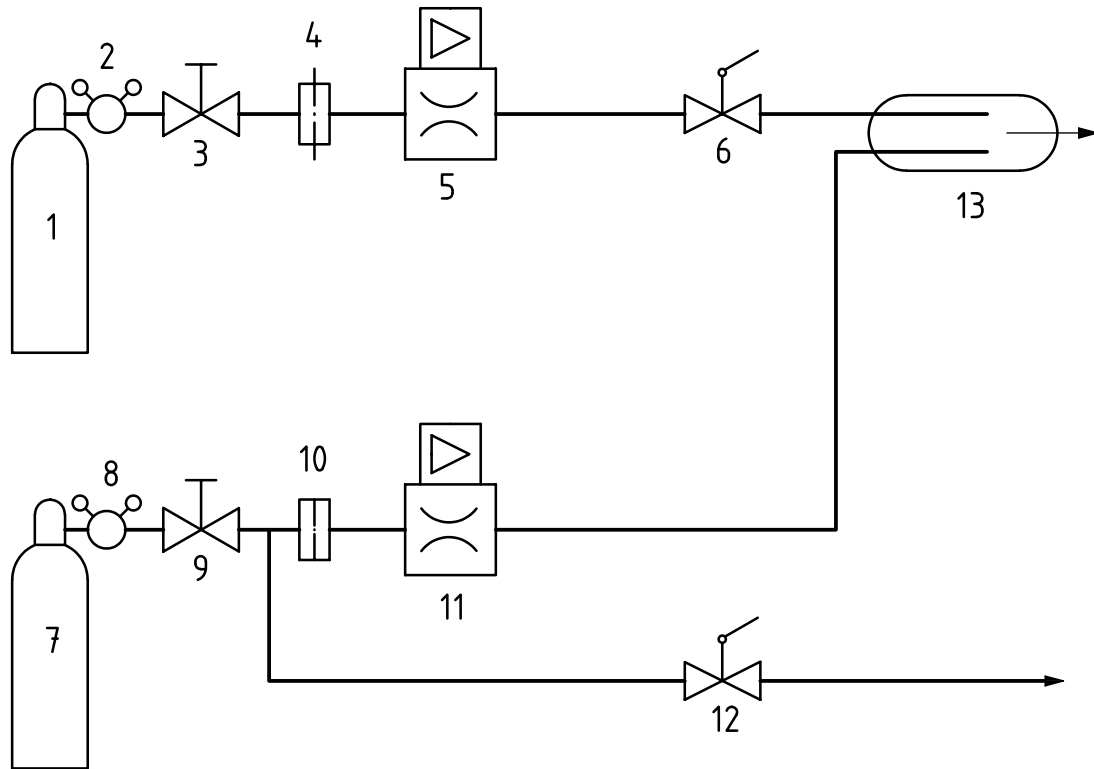

Key

Complementary gas:

- 1 cylinder of pressurized gas
- 2 pressure regulator
- 3 shut-off valve
- 4 filter against contamination
- 5 thermal mass-flow controller
- 6 shut-off valve

Calibration component:

- 7 cylinder of pressurized gas
- 8 pressure regulator
- 9 shut-off valve
- 10 filter against contamination
- 11 thermal mass-flow controller
- 12 shut-off valve
- 13 mixing vessel

Figure 3 — Mixing apparatus for production of binary gas mixtures by means of thermal mass-flow controllers

A binary mixture containing the calibration component at a volume fraction of 1:10 could be prepared using two thermal mass-flow controllers, each of full scale 1 000 ml/min, by operating one at 100 ml/min and the other at 1 000 ml/min. However, the expanded uncertainty in the flow rate of the former would be $\pm 10,00\%$ of the flow rate and the relative expanded uncertainty in the volume fraction would be $\pm 10,05\%$. To prepare the mixture to a relative expanded uncertainty of 2 %, the mixture shall be prepared using one thermal mass-flow controller of full-scale range 100 ml/min and the second one of full scale range 1 000 ml/min, both being operated at very close to full scale.

The same requirement shall be observed relative to preparation of multicomponent mixtures.

NOTE 1 A method for which there is no requirement for calibration against external standards of gas flow rate or volume fraction is described briefly in Annex B, and the reference to the publication which provides the complete description is given in the Bibliography.

Gas cylinders (1) and (7) containing respectively the complementary gas and the calibration component are connected to the thermal mass-flow controllers (5) and (11) through pressure regulators (2) and (8) and shut-off valves (3) and (9). The two in-line filters (4) and (10) provide protection against contamination. The gases from the flow controllers enter the mixing vessel (13).

The recommended working range for the pressure regulators is 60 kPa [0,6 bar¹] to 600 kPa (6,0 bar). The pressure regulator for the gaseous component shall also be suitable for the particular component involved (e.g. the diaphragm shall be of stainless steel or other corrosion-resistant material). Similarly, the thermal mass-flow controllers shall be suitable for use with the gaseous components and for the requirements of the gas mixture.

Set the input pressures appropriate to the controllers using the pressure regulators and open the shut-off valves (3), (6) and (9). Purge the inlet path of the gaseous component through the shut-off valve (12), which shall be of a type which can be operated rapidly.

Adjust the set-points of the controllers so as to obtain the respective flow rates in the correct ratio for the desired composition of the binary gas mixture; meanwhile, continue the purging process of the input tube for the component gas by multiple opening and closing of valve (12) until a total volume of gas at least 10 times the volume of the flow path has been vented.

When the system has been thoroughly purged, feed the gases via the thermal mass-flow controllers to the mixing vessel (13), constructed from inert materials. Provided that the resistance to flow downstream of the mixing vessel (13) is low in relation to the flow being delivered at the source, the mixture flows at ambient atmospheric pressure to the instrument.

NOTE 2 Although for most applications the gas mixture will be transmitted at the prevailing ambient atmospheric pressure, this method may also conceivably be applied to convey mixtures at elevated exit pressures. However, in this case, it would be necessary to give due consideration to changes in c_p and density of the gaseous components with pressure in order to assess the validity of this procedure.

6.2 Area of validity

The method is applicable to the preparation of mixtures of non-reacting species, i.e. those which do not react with any material of construction of the flow path in the thermal mass-flow controller or the ancillary equipment. Particular care shall be exercised if the method is considered as a means of preparing gaseous mixtures which contain components that form potentially explosive mixtures in air. Steps shall be taken to ensure that the apparatus is safe, for example by means of in-line flame arrestors in addition to the items listed in 6.1.

This method is not absolute and each thermal mass-flow controller shall be calibrated for the particular gas for which it is to be used.

6.3 Operating conditions

The conditions for efficient operation of the sensor system are that there shall be no heat loss or heat gain, other than that which results from the flow of gas, between the region of the heater and that of the downstream sensor, and that there shall be uniform temperature distribution across the gas stream. The assumption that c_p is constant is valid only over a restricted range of temperature. The general precautions common to all dynamic techniques of preparation shall be observed. It is essential that attention be paid to the materials used in the construction of the flow system. Only materials of low porosity, that are non-adsorbing are suitable. The pipework shall be clean and all unions secure.

1) 1 bar = 100 kPa = 0,1 MPa = 1 N/m².

Unless independence of the thermal mass-flow controller to its orientation has been established, it shall be maintained in the orientation in which it was calibrated. Controllers shall be calibrated for the components in question and it may be necessary to consult the manufacturer of the controller if the type of gas is to be changed; it may be necessary for the sensor to be changed.

7 Calculations

7.1 Volume fraction

The volume fraction is determined with reference to any of the methods of calibration described in Clause 4 of ISO 6145-1:2003. Due consideration shall be given to the uncertainty associated with the method selected.

Calibration of the thermal mass-flow controller will define the mass flow rate, q_m , or the volumetric flow rate, q_V , dependent on the method used.

$$q_m = \frac{\Phi}{c_p \Delta T} \quad (2)$$

$$q_V = \frac{\Phi}{c_p \rho \Delta T} \quad (3)$$

where ρ is the density of the component.

The mole fraction is:

$$x_A = \frac{q_{m,A}}{M_A} \bigg/ \left(\frac{q_{m,A}}{M_A} + \frac{q_{m,B}}{M_B} \right) \quad (4)$$

where

M_A and M_B are the molar masses of components A and B, respectively;

$q_{m,A}$ and $q_{m,B}$ are the values of mass flow rate, q_m , for components A and B, respectively.

The corresponding volume fraction is:

$$\varphi_A = q_{V,A} / (q_{V,A} + q_{V,B}) \quad (5)$$

7.2 Sources of uncertainty

Commercially available thermal mass-flow controllers usually indicate the gas flow rate in volume units as an analogue or digital display. Typical claims for accuracy are $\pm 1\%$ of full scale, provided that the ambient temperature is maintained within $\pm 5^\circ\text{C}$ of the temperature at which the instrument was calibrated. The corresponding claims for set-point repeatability are $\pm 0,2\%$ of full scale.

It is assumed that pressures and temperatures respectively are measured with the same instruments during calibration and use, so that the standard uncertainties in these measurements are constant throughout.

From Equations (2) and (3):

$$\frac{u(q_m)}{q_m} = \left\{ \left[\frac{u(\Phi)}{\Phi} \right]^2 + \left[\frac{u(c_p)}{c_p} \right]^2 + \left[\frac{u(\Delta T)}{\Delta T} \right]^2 \right\}^{1/2} \quad (6)$$

$$\frac{u(q_V)}{q_V} = \left\{ \left[\frac{u(\Phi)}{\Phi} \right]^2 + \left[\frac{u(c_p)}{c_p} \right]^2 + \left[\frac{u(\Delta T)}{\Delta T} \right]^2 + \left[\frac{u(\rho)}{\rho} \right]^2 \right\}^{1/2} \quad (7)$$

NOTE The expressions for relative combined uncertainty given in Equations (6) and (7) are provided for information only. They have been given in order to identify the parameters that contribute to $u(q_m)/q_m$ and $u(q_V)/q_V$. Φ and ΔT are functions of the mass-flow controller and the uncertainties are covered by the uncertainty quoted by the manufacturer (see also 6.1 and Annex C).

The following is a typical example of the relative change in c_p with temperature and pressure. These values show that the effects of pressure and temperature changes are negligible in comparison with the uncertainty inherent in the controller itself.

EXAMPLE With reference to effects of pressure and temperature changes, the relative change in c_p for nitrogen, for example, at 100 kPa (1 bar) for a change of 5 K in temperature from 290 K is approximately 0,000 2. The relative change in c_p at 290 K for a change in pressure from 100 kPa (1 bar) to 200 kPa (2 bar) is approximately 0,001.

7.3 Uncertainty of measurement

The uncertainty of the volume fraction of the calibration component in the calibration mixture, at constant temperature and pressure, can be estimated from the separate uncertainties in the flow rates of the calibration component and the complementary gas.

The volume fraction, $\varphi_{V,A}$, of component A is given by Equation (5).

The relative expanded uncertainty in $\varphi_{V,A}$ is then given by:

$$\frac{U(\varphi_{V,A})}{\varphi_{V,A}} = \left(\frac{2q_{V,B}}{q_{V,A} + q_{V,B}} \right) \left\{ \left[\frac{u(q_{V,A})}{q_{V,A}} \right]^2 + \left[\frac{u(q_{V,B})}{q_{V,B}} \right]^2 \right\}^{1/2} \quad (8)$$

NOTE The derivation of the above formula is summarized in C.1.

The coverage factor “2” has been applied in order to give a coverage probability of approximately 95 % in the case of normal distribution.

The uncertainty in the flow rates is estimated by calibration of the thermal mass-flow controllers by one of the methods presented in ISO 6145-1.

This estimate of the relative uncertainty in the composition depends entirely on the uncertainties in measurements of flow rates. The other factor to be taken into account is the efficiency of mixing. To check the effectiveness of a mixing system to provide a homogeneous calibration gas mixture, mixtures shall be prepared in accordance the method described in Clause 6 and the compositions shall be checked with reference to ISO 6143 (comparison method). The ambient pressure and temperature shall be recorded.

This procedure also identifies bias from other sources and establishes traceability against standard gas mixtures.

Annex A (informative)

Pre-mixed gases for preparation of mixtures of high dilution

A.1 Calculation of volume fraction

If pre-mixed gases are used instead of pure gases, mixtures of higher dilution can be prepared. Calculation of volume fraction is then as shown below (see also Reference [3]).

The volume fraction of component A in complementary gas B is given by:

$$\varphi_A = \frac{\varphi'_A q_{V,M} + \varphi''_A q_{V,B}}{q_{V,M} + q_{V,B}} = \frac{\varphi'_A q_{V,M} + \varphi''_A q_{V,B}}{q_\varphi} \quad (\text{A.1})$$

where

φ'_A is the volume fraction of A in the pre-mixed gas;

φ''_A is the volume fraction of A in the complementary gas B (this will normally be zero);

$q_{V,M}$ is the volume flow rate of the pre-mixed gas M;

$q_{V,B}$ is the volume flow rate of the complementary gas B;

q_φ is the volume flow rate of the calibration gas.

NOTE $q_\varphi = q_{V,M} + q_{V,B}$ only if there is no volume change on mixing.

A.2 Uncertainty of volume fraction

It is necessary to take into account the standard uncertainties of the volume flow rates and the standard uncertainties of the volume fractions of the component in the pre-mixed gas and also in the complementary gas (if relevant). Normally, the complementary gas will not contain the active component.

In cases where the complementary gas does not contain the active component A:

$$\varphi_A = \frac{\varphi'_A q_{V,M}}{q_{V,M} + q_{V,B}} \quad (\text{A.2})$$

and the relative standard uncertainty in the volume fraction, $\Phi_{V,A}$, is given by:

$$\frac{u(\varphi_A)}{\varphi_A} = \frac{q_{V,B}}{q_{V,B} + q_{V,M}} \left\{ \left[\frac{u(q_{V,M})}{q_{V,M}} \right]^2 + \left[\frac{u(q_{V,B})}{q_{V,B}} \right]^2 + \left[\frac{q_{V,M} + q_{V,B}}{q_{V,B}} \right]^2 \left[\frac{u(\varphi'_A)}{\varphi'_A} \right]^2 \right\}^{1/2} \quad (\text{A.3})$$

The derivation of this equation is shown in C.2.

Annex B (informative)

Practical hints

B.1 Equipment

The complete flow system should be clean and free from particulates.

Pressure regulators and associated pipework should be dedicated to use with specific gaseous components.

The thermal mass-flow controller should be maintained in the same orientation when it is calibrated and when used for the preparation of gas mixtures.

The operating ranges should be appropriate for the gaseous component, mixing ratio, minimum flow rate and the possible volume fractions.

NOTE The requirement that the thermal mass-flow controllers be operated near to full scale is given in 6.1.

Shut-off valves should be installed between pressure regulators and thermal mass-flow controllers in order to ensure that there is no leakage past the regulators.

All dimensions of the flow paths and the materials of construction should be carefully selected so that interaction with the gaseous components is minimized. In particular, pressure regulators should be suitable for the gases which they are to convey. GC-quality stainless steel should be used to convey reactive components. It is permissible for non-reactive complementary gases to be conveyed in plastics materials such as polyethylene or polytetrafluorethylene. If there is any risk of adsorption, however, stainless steel should be used.

The nominal inner diameter of the conveyance tubes should be 1,5 mm to 2,0 mm for the active component and 4,0 mm to 6,0 mm for the complementary gas.

B.2 Operation

Before using the calibration gases, ensure that the pipework for the active component is sufficiently purged with the component concerned. A short period is satisfactory in the case of pure gas or pre-mixed gases at higher volume fractions, but several hours are necessary for the more dilute pre-mixed gases (below 10^{-4} by volume).

When calibrating gas analysers at normal atmospheric pressures, the calibration gas should be supplied at no excess pressure; suitable bypass tubes should therefore be provided. The excess depends upon the calibration gas component and the pressure dependence of the analyser.

In the case of corrosive or toxic gases, any excess flow should be safely vented, but long runs of venting pipework should be avoided in order to minimize back-pressure effects.

In the event of short interruption in the analyser calibration procedure, conveyance of the gases should not be arrested, and if connecting tubes are removed, they should be adequately sealed against contamination.

B.3 Calibration and precision

A high-accuracy gas-flow dilution system using mass-flow controllers, but not restricted to thermal mass-flow controllers, has been developed and is described in Reference [4]. To gain an appreciation of the method, which has been employed to provide a variety of volume fractions to a typical uncertainty of $\pm 0,4$ % of volume fraction, the original paper should be read. The paper details the uncertainty analysis on the basis of the flow rates of the calibration component and the emergent calibration gas, and the method has been verified experimentally against gravimetric methods. Eleven literature references are provided.

An additional paper (Reference [5]) describes an improved approach to calculating the uncertainties of thermal mass-flow controllers. The paper provides a review of the mathematical basis for a general least-squares solution to the determination of best-fit calibration curves, and separates the systematic contribution to the uncertainty which results from the calibration of the flow system from the random uncertainty incurred each time the system is operated. In an appendix to the paper, the experimental and mathematical procedures are illustrated with reference to the gas flow dilution system that is the subject of Reference [4], but it is equally applicable in principle to the method of preparation of binary gas mixtures described in this part of ISO 6145. Twenty-five literature references are provided.

Annex C (informative)

Calculation of uncertainties

C.1 Derivation of the relative standard uncertainty in $\varphi_{V,A}$

The symbols are those given in 7.3 and Annex A, except that the suffix “V” (for example in $q_{V,A}$) has been omitted in order to simplify the formulae.

The concentration of component A in a mixture of A and complementary gas B is given by:

$$\varphi_A = \frac{q_A}{q_A + q_B} \tag{C.1}$$

in which q_A and q_B are, respectively, the flow rates of the components A and B.

The uncertainty in φ_A is:

$$u(\varphi_A) = \left\{ \left(\frac{\partial \varphi_A}{\partial q_A} \right)^2 [u(q_A)]^2 + \left(\frac{\partial \varphi_A}{\partial q_B} \right)^2 [u(q_B)]^2 \right\}^{1/2} \tag{C.2}$$

By differentiation of Equation (C.1):

$$\left(\frac{\partial \varphi_A}{\partial q_A} \right)^2 = \left[\frac{q_B}{(q_A + q_B)^2} \right]^2$$

$$\left(\frac{\partial \varphi_A}{\partial q_B} \right)^2 = \left[\frac{-q_A}{(q_A + q_B)^2} \right]^2$$

and by substitution in Equation (C.2), the relative standard uncertainty is:

$$\begin{aligned} \frac{u(\varphi_A)}{\varphi_A} &= \left(\frac{q_A + q_B}{q_A} \right) \left[\frac{1}{(q_A + q_B)^2} \right] \left\{ q_B^2 [u(q_A)]^2 + q_A^2 [u(q_B)]^2 \right\}^{1/2} \\ &= \frac{q_A q_B}{q_A (q_A + q_B)} \left\{ \left[\frac{u(q_A)}{q_A} \right]^2 + \left[\frac{u(q_B)}{q_B} \right]^2 \right\}^{1/2} \\ &= \frac{q_B}{q_A + q_B} \left\{ \left[\frac{u(q_A)}{q_A} \right]^2 + \left[\frac{u(q_B)}{q_B} \right]^2 \right\}^{1/2} \end{aligned}$$

The coverage factor “2” is applied in 7.3 to give a 95 % coverage probability.

C.2 Uncertainty of volume fractions by mathematical derivation

The expression of uncertainty described in this subclause has been derived for the mass-flow controller method, but is equally applicable to other methods described in the various parts of ISO 6145.

The symbols are those given in 7.3 and Annex A, except that the suffix “V” (for example in $q_{V, M}$) has been omitted in order to simplify the formulae.

On the assumption that the complementary gas B does not contain component A:

$$\varphi_A = \frac{\varphi'_A q_M}{q_M + q_B} \quad (\text{C.3})$$

and the standard uncertainty in φ_A is:

$$u(\varphi_A) = \left\{ \left[\frac{\partial \varphi_A}{\partial q_M} \right]^2 [u(q_M)]^2 + \left[\frac{\partial \varphi_A}{\partial q_B} \right]^2 [u(q_B)]^2 + \left[\frac{\partial \varphi_A}{\partial \varphi'_A} \right]^2 [u(\varphi'_A)]^2 \right\}^{1/2} \quad (\text{C.4})$$

By differentiation of Equation (C.3):

$$\left(\frac{\partial \varphi_A}{\partial q_M} \right)^2 = \left[\frac{\varphi'_A q_B}{(q_M + q_B)^2} \right]^2$$

$$\left(\frac{\partial \varphi_A}{\partial q_B} \right)^2 = \left[\frac{\varphi'_A q_M}{(q_M + q_B)^2} \right]^2$$

$$\left(\frac{\partial \varphi_A}{\partial \varphi'_A} \right)^2 = \left(\frac{q_M}{q_M + q_B} \right)^2$$

and by substitution in Equation (C.4) and dividing by φ_A , the relative standard uncertainty in φ_A is:

$$\begin{aligned} \frac{u(\varphi_A)}{\varphi_A} &= \frac{q_M + q_B}{\varphi'_A q_M} \left\{ \left[\frac{\varphi'_A q_B}{(q_M + q_B)^2} \right]^2 [u(q_M)]^2 + \left[\frac{\varphi'_A q_M}{(q_M + q_B)^2} \right]^2 [u(q_B)]^2 + \left[\frac{q_M}{q_M + q_B} \right]^2 [u(\varphi'_A)]^2 \right\}^{1/2} \\ &= \frac{1}{\varphi'_A q_M} \left\{ \left(\frac{\varphi'_A q_B}{q_M + q_B} \right)^2 [u(q_M)]^2 + \left(\frac{\varphi'_A q_M}{q_M + q_B} \right)^2 [u(q_B)]^2 + q_M^2 [u(\varphi'_A)]^2 \right\}^{1/2} \\ &= \frac{q_M q_B}{\varphi'_A q_M} \left\{ \left(\frac{\varphi'_A}{q_M + q_B} \right)^2 \left[\frac{u(q_M)}{q_M} \right]^2 + \left(\frac{\varphi'_A}{q_M + q_B} \right)^2 \left[\frac{u(q_B)}{q_B} \right]^2 + \frac{q_M^2 [u(\varphi'_A)]^2}{q_M^2 q_B^2} \right\}^{1/2} \\ &= \frac{q_B}{\varphi'_A} \left\{ \left(\frac{\varphi'_A}{q_M + q_B} \right)^2 \left[\frac{u(q_M)}{q_M} \right]^2 + \left(\frac{\varphi'_A}{q_M + q_B} \right)^2 \left[\frac{u(q_B)}{q_B} \right]^2 + \left[\frac{u(\varphi'_A)}{q_B} \right]^2 \right\}^{1/2} \end{aligned}$$

$$= \frac{q_B}{q_M + q_B} \left\{ \left[\frac{u(q_M)}{q_M} \right]^2 + \left[\frac{u(q_B)}{q_B} \right]^2 + \left(\frac{q_M + q_B}{q_B} \right)^2 \left[\frac{u(\varphi'_A)}{\varphi'_A} \right]^2 \right\}^{1/2}$$

The coverage factor “2” is to be applied to give a 95 % coverage probability in the case of normal distribution.

Bibliography

- [1] ISO 14511:2001, *Measurement of fluid flow in closed conduits — Thermal mass flowmeters*
- [2] TISON, S.A. (NIST). A critical evaluation of thermal mass flow meters. *J. Vacuum Science Tech. A*, **14**(4), 1996, pp. 2582-2591
- [3] ISO/IEC Guide 98-3, *Uncertainty of measurement — Part 3: Guide to the expression of uncertainty in measurement (GUM:1995)*
- [4] GOODY, B.A. and MILTON, M.J.T. (NPL). High-accuracy gas flow dilutor using mass flow controllers with binary weighted flows. *Meas. Sci. Technol.*, **13**, 2002, pp. 1138-1145
- [5] MILTON, M.J.T., HARRIS, P.M., SMITH, I.M., BROWN, A.S. and GOODY, B.A. (NPL). Implementation of a generalized least-squares method for determining calibration curves from data with general uncertainty structures. *Metrologia*, **43**, 2006, pp. S291-S298
- [6] ISO 6142, *Gas analysis — Preparation of calibration gas mixtures — Gravimetric method*

ICS 71.040.40

Price based on 15 pages

BSI - British Standards Institution

BSI is the independent national body responsible for preparing British Standards. It presents the UK view on standards in Europe and at the international level. It is incorporated by Royal Charter.

Revisions

British Standards are updated by amendment or revision. Users of British Standards should make sure that they possess the latest amendments or editions.

It is the constant aim of BSI to improve the quality of our products and services. We would be grateful if anyone finding an inaccuracy or ambiguity while using this British Standard would inform the Secretary of the technical committee responsible, the identity of which can be found on the inside front cover. Tel: +44 (0)20 8996 9000. Fax: +44 (0)20 8996 7400.

BSI offers members an individual updating service called PLUS which ensures that subscribers automatically receive the latest editions of standards.

Buying standards

Orders for all BSI, international and foreign standards publications should be addressed to Customer Services. Tel: +44 (0)20 8996 9001. Fax: +44 (0)20 8996 7001 Email: orders@bsigroup.com You may also buy directly using a debit/credit card from the BSI Shop on the Website <http://www.bsigroup.com/shop>

In response to orders for international standards, it is BSI policy to supply the BSI implementation of those that have been published as British Standards, unless otherwise requested.

Information on standards

BSI provides a wide range of information on national, European and international standards through its Library and its Technical Help to Exporters Service. Various BSI electronic information services are also available which give details on all its products and services. Contact Information Centre. Tel: +44 (0)20 8996 7111 Fax: +44 (0)20 8996 7048 Email: info@bsigroup.com

Subscribing members of BSI are kept up to date with standards developments and receive substantial discounts on the purchase price of standards. For details of these and other benefits contact Membership Administration. Tel: +44 (0)20 8996 7002 Fax: +44 (0)20 8996 7001 Email: membership@bsigroup.com

Information regarding online access to British Standards via British Standards Online can be found at <http://www.bsigroup.com/BSOL>

Further information about BSI is available on the BSI website at <http://www.bsigroup.com>

Copyright

Copyright subsists in all BSI publications. BSI also holds the copyright, in the UK, of the publications of the international standardization bodies. Except as permitted under the Copyright, Designs and Patents Act 1988 no extract may be reproduced, stored in a retrieval system or transmitted in any form or by any means – electronic, photocopying, recording or otherwise – without prior written permission from BSI.

This does not preclude the free use, in the course of implementing the standard, of necessary details such as symbols, and size, type or grade designations. If these details are to be used for any other purpose than implementation then the prior written permission of BSI must be obtained.

Details and advice can be obtained from the Copyright and Licensing Manager. Tel: +44 (0)20 8996 7070 Email: copyright@bsigroup.com