

BS EN ISO 5923:2012



BSI Standards Publication

**Equipment for fire
protection and fire fighting**
— Fire extinguishing media
— Carbon dioxide

bsi.

...making excellence a habit.™

National foreword

This British Standard is the UK implementation of EN ISO 5923:2012. It supersedes BS EN 25923:1994 which is withdrawn.

The UK participation in its preparation was entrusted by Technical Committee FSH/18, Fixed fire fighting systems, to Subcommittee FSH/18/6, Gaseous Extinguishing Media and Systems.

A list of organizations represented on this committee can be obtained on request to its secretary.

This publication does not purport to include all the necessary provisions of a contract. Users are responsible for its correct application.

© The British Standards Institution 2012

Published by BSI Standards Limited 2012

ISBN 978 0 580 74002 2

ICS 13.220.10

Compliance with a British Standard cannot confer immunity from legal obligations.

This British Standard was published under the authority of the Standards Policy and Strategy Committee on 31 August 2012.

Amendments issued since publication

Amd. No.	Date	Text affected
----------	------	---------------

EUROPEAN STANDARD
NORME EUROPÉENNE
EUROPÄISCHE NORM

EN ISO 5923

August 2012

ICS 13.220.10

Supersedes EN 25923:1993

English Version

Equipment for fire protection and fire fighting - Fire extinguishing media - Carbon dioxide (ISO 5923:2012)

Équipement de protection et de lutte contre l'incendie -
Agents extincteurs - Dioxyde de carbone (ISO 5923:2012)

Ausrüstung für Brandschutz und Brandbekämpfung -
Löschmittel - Kohlenstoffdioxid (ISO 5923:2012)

This European Standard was approved by CEN on 14 August 2012.

CEN members are bound to comply with the CEN/CENELEC Internal Regulations which stipulate the conditions for giving this European Standard the status of a national standard without any alteration. Up-to-date lists and bibliographical references concerning such national standards may be obtained on application to the CEN-CENELEC Management Centre or to any CEN member.

This European Standard exists in three official versions (English, French, German). A version in any other language made by translation under the responsibility of a CEN member into its own language and notified to the CEN-CENELEC Management Centre has the same status as the official versions.

CEN members are the national standards bodies of Austria, Belgium, Bulgaria, Croatia, Cyprus, Czech Republic, Denmark, Estonia, Finland, Former Yugoslav Republic of Macedonia, France, Germany, Greece, Hungary, Iceland, Ireland, Italy, Latvia, Lithuania, Luxembourg, Malta, Netherlands, Norway, Poland, Portugal, Romania, Slovakia, Slovenia, Spain, Sweden, Switzerland, Turkey and United Kingdom.



EUROPEAN COMMITTEE FOR STANDARDIZATION
COMITÉ EUROPÉEN DE NORMALISATION
EUROPÄISCHES KOMITEE FÜR NORMUNG

Management Centre: Avenue Marnix 17, B-1000 Brussels

Contents

Page

Foreword.....	3
---------------	---

Foreword

This document (EN ISO 5923:2012) has been prepared by Technical Committee ISO/TC 21 "Equipment for fire protection and fire fighting" in collaboration with Technical Committee CEN/TC 191 "Fixed firefighting systems" the secretariat of which is held by BSI.

This European Standard shall be given the status of a national standard, either by publication of an identical text or by endorsement, at the latest by February 2013, and conflicting national standards shall be withdrawn at the latest by February 2013.

Attention is drawn to the possibility that some of the elements of this document may be the subject of patent rights. CEN [and/or CENELEC] shall not be held responsible for identifying any or all such patent rights.

This document supersedes EN 25923:1993.

According to the CEN/CENELEC Internal Regulations, the national standards organizations of the following countries are bound to implement this European Standard: Austria, Belgium, Bulgaria, Croatia, Cyprus, Czech Republic, Denmark, Estonia, Finland, Former Yugoslav Republic of Macedonia, France, Germany, Greece, Hungary, Iceland, Ireland, Italy, Latvia, Lithuania, Luxembourg, Malta, Netherlands, Norway, Poland, Portugal, Romania, Slovakia, Slovenia, Spain, Sweden, Switzerland, Turkey and the United Kingdom.

Endorsement notice

The text of ISO 5923:2012 has been approved by CEN as a EN ISO 5923:2012 without any modification.

Contents

	Page
Introduction	v
1 Scope	1
2 Normative references	1
3 Terms and definitions	1
4 Requirements	1
5 Sampling	2
5.1 General	2
5.2 Sampling equipment	2
5.3 Procedure	2
6 Methods of test	3
6.1 Safety warning	3
6.2 Purity	3
6.3 Water content	3
6.4 Oil content	3
6.5 Total sulfur compounds content	3
7 Packaging and labelling	3
Annex A (informative) Determination of water content	4
Annex B (normative) Determination of oil content	6
Annex C (normative) Determination of total sulfur compounds content	9
Annex D (informative) General properties	12
Annex E (normative) Precautions for handling	13
Annex F (informative) Compatibility	14
Annex G (informative) Toxicology	15

Introduction

This International Standard is one of a series of other International Standards giving specifications for fire extinguishing media in common use and which are in need of a specification for fire fighting purposes. These specifications are designed to establish that the medium in question has at least a minimum useful fire extinguishing capability and can therefore be reasonably sold for fire extinguishing purposes.

Requirements for media used in particular equipment will form the subject of future International Standards.

Annexes A to C of this International Standard specify methods for determining, respectively, water, oil and total sulfur compounds contents. Annexes D to G provide important information on, and give recommendations relating to, the safety and use of carbon dioxide, and they should be read carefully by all concerned with this medium.

Equipment for fire protection and fire fighting — Fire extinguishing media — Carbon dioxide

1 Scope

This International Standard specifies requirements for carbon dioxide for use as a fire extinguishing medium.

2 Normative references

The following referenced documents are indispensable for the application of this document. For dated references, only the edition cited applies. For undated references, the latest edition of the referenced document (including any amendments) applies.

ISO 385:2005, *Laboratory glassware — Burettes*

ISO 648:2008, *Laboratory glassware — Single-volume pipettes*

ISO 2591-1:1988, *Test sieving — Part 1: Methods using test sieves of woven wire cloth and perforated metal plate*

ISO 3310-1:2000, *Test sieves — Technical requirements and testing — Part 1: Test sieves of metal wire cloth*

3 Terms and definitions

For the purposes of this document, the following definition applies.

3.1

carbon dioxide

CO_2

chemical compound CO_2 used as a fire extinguishing medium

4 Requirements

Carbon dioxide shall comply with the requirements of Table 1 below, when tested by the appropriate method of test specified in Clause 6.

Table 1 — Requirements for carbon dioxide properties

Property	Requirements
Purity, o/o (V/V) min.	99,5
Water content, o/o (m/m) max.	0,015
Oil content, ppm by mass, max.	5
Total sulfur compounds content, expressed as sulfur, ppm by mass, max.	5,0
NOTE Carbon dioxide obtained by converting dry ice to liquid will not usually comply with these requirements unless it has been properly processed to remove excess water and oil.	

5 Sampling

5.1 General

Samples of carbon dioxide needed to perform all of the tests required by this International Standard shall be taken from the same manufacturing lot, using identical sampling procedures.

NOTE Attention is drawn to the need to design equipment for handling carbon dioxide such that it is either capable of withstanding the pressures involved or is protected from them.

5.2 Sampling equipment

Rigid metal connections or a flexible reinforced nylon hose should be used throughout the sampling equipment and shall be kept as short as possible. All components shall have a design pressure of not less than 137 bar.

5.3 Procedure

5.3.1 General

Two methods of sampling are specified:

- a) direct sampling, in which the sample is passed to an evaporator and then directly to the analytical apparatus;
- b) sampling in cylinders, in which case the sample is transferred in a cylinder to a laboratory.

Other methods may be used provided that they are shown to give equally representative samples on analysis (see Annexes A to C).

5.3.2 Direct sampling

Connect the sampling valve by means of suitable connections (see 5.2) to an evaporating device and then via a T-piece (the free leg of which is connected to the dip-tube of a Drechsel bottle containing 50 mm of mercury covered by a layer of water on the carbon dioxide side) to the analytical apparatus. Thoroughly flush the connections, valves and the evaporating device with carbon dioxide before starting to take the sample.

5.3.3 Sampling in cylinders

Use a cylinder of water capacity 1,4 kg or 2,0 kg and with a valve at each end.

An internal copper dip-tube of diameter at least 5 mm and of length equal to one-third of the length of the cylinder shall be brazed to the base of one valve, which shall be clearly identified. The cylinder shall be coated internally with tin [containing 1 % (m/m) of lead] applied by hot dipping the cylinder after the walls have been descaled.

First clean the sampling cylinder by removing both valves and washing the inside of the cylinder with carbon tetrachloride. Purge with a current of dry filtered air. Wash with methanol and repeat the purging. Degrease the valves using carbon tetrachloride, then refit them. The methanol and carbon tetrachloride used shall comply with the requirements specified in B.2.

Support the cylinder vertically with its dip-tube valve uppermost. Before taking the sample, thoroughly flush the cylinder with a small quantity of liquid carbon dioxide, first through the top valve and then through the bottom valve. Repeat this flushing procedure, and leave the cylinder connected to the liquid carbon dioxide source via its lower valve. Then, with the upper valve closed, open the lower valve to admit liquid carbon dioxide to the cylinder. Partly open the upper (dip-tube) valve and continue filling until carbon dioxide snow is discharged from this valve. Close both valves. Open the top valve several times for brief intervals until only carbon dioxide gas is discharged from it. The free end of the dip-tube inside the cylinder will then be just above the liquid carbon dioxide level in the cylinder.

Samples shall be analysed as soon as reasonably practicable after collection. To withdraw the sample for analysis, support the sampling cylinder vertically with the dip-tube valve at the top. Connect the bottom valve

of the sampling cylinder (liquid carbon dioxide) to an evaporating device and thence via a T-piece, the free leg of which is connected to a tube as described in 5.3.2, to the analytical apparatus. Thoroughly flush the connections, valves and the evaporating device with carbon dioxide before starting the analysis.

When sampling for the determination of water content, heat the connections to above the dew point to prevent condensation during purging.

6 Methods of test

6.1 Safety warning

Attention is drawn to the need to design equipment for handling carbon dioxide such that it is either capable of withstanding the pressures involved or is protected from them.

6.2 Purity

Determine the purity by gas-liquid chromatography, using generally accepted laboratory techniques, or use a volumetric analyser.

The method used shall be capable of determining the purity with an accuracy of at least 0,1 %.

The sample shall not constitute more than 10 % of the original quantity of carbon dioxide contained in the sample container.

6.3 Water content

Determine the water content by the method specified in Annex A or by any other method giving equivalent results.

6.4 Oil content

Determine the oil content by the method specified in Annex B or by any other method giving equivalent results.

6.5 Total sulfur compounds content

Determine the total sulfur compounds content by the method specified in Annex C or by any other method giving equivalent results.

7 Packaging and labelling

7.1 Carbon dioxide shall be shipped and stored in containers that will not alter the medium or be detrimentally affected by it.

NOTE The containers may need to comply with national regulations.

7.2 Containers shall be marked with the following information:

- a) supplier's name and address;
- b) "carbon dioxide";
- c) package identification number;
- d) the number of this International Standard, i.e. ISO 5923:2012;
- e) recommended storage precautions.

Annex A (informative)

Determination of water content

A.1 Principle

Gravimetric determination of the water content by passing a sample of the gas over phosphorus pentoxide.

A.2 Apparatus and material

A.2.1 Two absorption tubes, U-shape, the length of the limbs being 100 mm and the diameter of the tubes being 12 mm, fitted with side arms and ground-glass drilled stoppers.

The tubes shall be filled with the desiccant (A.2.5), which shall be held in position by small pads of cotton wool.

A.2.2 Flow meter (if desired), float type, suitable for measuring a carbon dioxide flow of 200 ml/min to 2 000 ml/min.

A.2.3 Gas meter, calibrated for 1 l or 2,5 l per revolution.

A.2.4 Test sieves, of aperture sizes 425 μm and 600 μm , complying with the requirements of ISO 3310-1:2000.

A.2.5 Desiccant

Sift powdered glass or clean, dry, washed sand and retain the portion that passes through a test sieve of aperture size 600 μm but is retained on a test sieve of aperture size 425 μm .

In general, follow the applicable recommendations and requirements of ISO 2591-1:1988.

Quickly transfer a volume of fresh phosphorus pentoxide to a stoppered container (a large weighing bottle or small stoppered jar is suitable) and add about half as much by volume of the prepared powdered glass or sand. Vigorously shake the container to mix the components and fill the U-tubes (A.2.1) as quickly as possible with the mixture.

If it is prepared in this way, it should be easy to fill the tube with the desiccant. If it is not easy, it is probable that the phosphorus pentoxide was moist before the addition of the powdered glass or sand.

Prepare the desiccant in small quantities, as required.

A.3 Sampling

Take the sample in a cylinder by the method described in 5.3.3. About 120 g of carbon dioxide is required for each determination.

A.4 Determination

After the evaporating device, connect the exit side of the T-piece to the absorption tubes (A.2.1), the flow meter (A.2.2) and the gas meter (A.2.3) in series, in that order.

Carefully open the regulating valve and absorption tube taps and allow the gas to flow at a flow rate of about 500 ml/min for 10 min, until the carbon dioxide displaces the air in the absorption tubes. Close all taps,

disconnect the absorption tubes and wipe the tube surfaces with a dry, soft cloth. Place the absorption tubes in the balance case, leave for 20 min, then weigh them to the nearest 0,5 mg.

Reconnect the absorption tubes. Note the reading of the gas meter, then allow the gas to pass at a steady rate of 500 ml/min to 1 000 ml/min for 1 h.

Close the taps and reducing valve. Note the gas meter reading. Place the absorption tubes in the balance case, leave for 20 min, then weigh them to the nearest 0,5 mg.

A.5 Expression of results

The water content, expressed as a percentage by mass, is given by the formula:

$$\frac{54,29 (m_2 - m_1)}{V}$$

where

m_1 is the initial mass, in grams, of the absorption tubes;

m_2 is the final mass, in grams, of the absorption tubes;

V is the volume, in litres, at 20 °C and 760 mmHg¹⁾, of gas passed, read from the gas meter.

1) 1 mmHg = 101,3 kPa.

Annex B (normative)

Determination of oil content

B.1 Principle

Vaporization of a liquid sample and removal of any oil by passing the gas through carbon tetrachloride. Removal of residual oil in the cylinder by washing with more carbon tetrachloride and a combination of the two carbon tetrachloride solutions. Spectrometric measurement of the oil content at 3 460 nm (the C-H stretching frequency) by means of an infrared spectrometer.

B.2 Reagents

All reagents shall be of recognized analytical grade.

B.2.1 Carbon tetrachloride, distilled

The reagent shall not show an infrared absorption peak at 3 460 nm.

B.2.2 Standard oil solution

Dissolve 0,0200 g of liquid paraffin in carbon tetrachloride, transfer quantitatively to a 100 ml one-mark volumetric flask and dilute to the mark with carbon tetrachloride.

1 ml of this solution contains 200 µg of oil.

B.3 Apparatus

B.3.1 Two bubblers, as shown in Figure B.1.

B.3.2 Drechsel bottle, of capacity 250 ml.

B.3.3 Flow meter, float type, suitable for measuring a carbon dioxide flow of 200 ml/min to 2 000 ml/min.

B.3.4 Gas meter, calibrated for 1 l or 2,5 l per revolution.

B.3.5 Infrared spectrometer and accessories, suitable for making measurements at 3 460 nm.

B.4 Sampling

Take the sample by the method described in B.3.3. About 700 g to 1 000 g is required for each determination.

A set of cylinders should preferably be retained for sampling for the determination of oil content and should not be used for other purposes.

B.5 Procedure

B.5.1 Preparation of test solution

Place 100 ml of the carbon tetrachloride (B.2.1) in the Drechsel bottle (B.3.2) and 25 ml in each bubbler (B.3.1). Support the weighed sampling cylinder with the dip-tube valve at the top, connect the bottom valve of the weighed cylinder to the T-piece of the evaporating device and then to the Drechsel bottle, the two bubblers, the flow meter and the gas meter in series, in that order, using short rubber connections.

No carbon dioxide shall be allowed to pass to the atmosphere through the outlet of the T-piece.

Weigh the cylinder, totally expand the contents of the cylinder through the absorption train at a flow rate of about 1 000 ml/min, and read the volume of gas passed (this serves as a check on the amount of carbon dioxide used for the test).

NOTE Some evaporation of the carbon tetrachloride will take place. If this is excessive, stop the flow of gas and refill the absorption bottles, noting the volume of carbon tetrachloride.

In view of the toxic nature of carbon tetrachloride, the effluent gas from this determination should be discharged to the outside air.

Reweigh the sampling cylinder, taking care to use the same valve fittings as at the first weighing. Remove the valve not attached to the dip-tube and wash the inside of the cylinder with 25 ml of the carbon tetrachloride. Wash the interior of the evaporating device and valves with carbon tetrachloride and combine this solution with the cylinder washings and the contents of the bubblers. Make up the combined solutions to some suitable, definite volume.

B.5.2 Preparation of blank test solution

Evaporate a volume of carbon tetrachloride, equal to the total volume (including any additions) of carbon tetrachloride used in the absorption train plus washings, to the volume of the combined solution (see B.5.1) and subsequently treat it in the same way as the test solution.

B.5.3 Spectrometric measurements

Following the manufacturer's instructions for the operation of the instrument, determine the absorbances of the test solution and of the blank test solution at the wavelength of maximum absorption (approximately 3 460 nm). From the calibration graph (B.5.4), deduce the masses of oil corresponding to the measured absorbances.

B.5.4 Preparation of the calibration graph

Prepare suitable dilutions of the standard oil solution (B.2.2) to cover the range within which the mass of oil in the sample is expected to be found. Measure the absorbance of each of these solutions as described in B.5.3. Prepare a calibration graph by plotting the masses of oil against the corresponding absorbances.

B.6 Expression of results

The oil content, expressed in parts per million by mass, is given by the formula:

$$\frac{m_3 - m_4}{m_5}$$

where

m_3 is the mass, in micrograms, of the oil in the test solution;

m_4 is the mass, in micrograms, of the oil in the blank test solution;

m_5 is the mass, in grams, of the sample taken.

NOTE The mass, m_5 , can be checked by calculating it from the mass of 1 l of carbon dioxide at 20 °C and 1 013 mbar (760 mmHg²⁾, which is 1,84 g.

Dimensions in millimetres

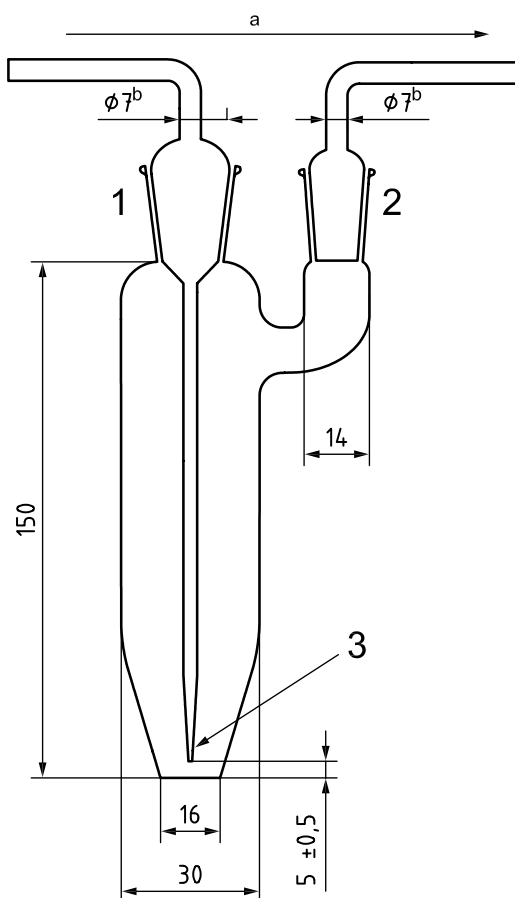

Key

- 1 19/26 joint
- 2 14/23 joint
- 3 orifice jet $1,0 \pm 0,1$
- a Direction of gas flow.
- b φ ext 7.

Figure B.1 — Bubbler for the determination of oil content

2) 1 mmHg = 101,3 kPa.

Annex C (normative)

Determination of total sulfur compounds content

C.1 Principle

Reduction of any sulfur compounds present by passing equal volumes of the sample and purified hydrogen over silica wool at 900 °C. Removal of the hydrogen sulfide thus produced by passing the gases through neutral cadmium chloride solution. Determination of sulfur by adding a known amount of iodine solution and determining the excess iodine by titration with standard volumetric sodium thiosulfate solution.

C.2 Reagents

All reagents shall be of recognized analytical grade, and the water used shall be distilled water or water of equivalent purity.

C.2.1 Hydrogen, gas produced electrolytically.

C.2.2 Hydrochloric acid, concentrated, 1,18 g/ml.

C.2.3 Soda lime, in lumps which pass a test sieve of aperture size 2 mm, but which are retained on a test sieve of aperture size 1,8 mm.

NOTE The soda lime should not have been used in other determinations where oxygen has been used, as explosions may occur.

C.2.4 Cadmium chloride, 50 g/l neutral solution.

Dissolve 5 g of cadmium chloride in 100 ml of water and add, drop by drop, approximately 1 mol/l sodium hydroxide solution until the first cloudiness appears.

C.2.5 Sodium thiosulfate, standard volumetric solution, $c(\text{Na}_2\text{S}_2\text{O}_3) = 0,02$ mol/l solution.

C.2.6 Iodine, standard volumetric solution, $c(\text{I}_2) = 0,01$ mol/l solution.³⁾

C.2.7 Starch indicator solution.

Make a paste of 1 g of soluble starch with a little water, pour the paste, stirring constantly, into 100 ml of boiling water and boil for 1 min. Allow to cool.

C.3 Apparatus

NOTE The apparatus is shown diagrammatically in Figure C.1.

C.3.1 Flow meter, float type, suitable for measuring a hydrogen flow of 200 ml/min to 2 000 ml/min.

C.3.2 Flow meter, float type, suitable for measuring a carbon dioxide flow of 200 ml/min to 2 000 ml/min.

3) Hitherto expressed as "0,02 N standard volumetric solution".

C.3.3 Two furnace tubes, made of transparent silica, each 500 mm long, of internal diameter 16 mm, with one end reduced to 3 mm internal diameter.

Place a loose packing of silica wool not less than 200 mm long in the tube with a small plug of silica wool near the wide end to reduce radiation heating of the polyvinyl chloride connection.

C.3.4 Furnace and control, a twin-tube furnace, about 460 mm long, to operate at 900 °C, and fitted with a thermocouple and temperature indicator.

C.3.5 Soda lime tower, or suitable absorption tube.

C.3.6 “Y” tube.

C.3.7 Bubbler, as shown in Figure B.1.

C.3.8 Burette, of capacity 10 ml, complying with the requirements of ISO 385:2005, class A.

C.3.9 Pipette, of capacity 2 ml, complying with the requirements of ISO 648:2008, class A.

C.3.10 Test sieves, of aperture size 2 mm and 1,8 mm, complying with the requirements of ISO 3310-1:2000.

C.4 Sampling

Take the sample in a cylinder by the method described in 5.3.3. About 120 g is required for each determination.

Connect the outlet of the evaporating device to the apparatus shown in Figure C.1. All connections shall be as short as possible and shall be made of polyethylene or polyvinyl chloride.

C.5 Procedure

Place 25 ml of the neutral cadmium chloride solution (C.2.4) in the absorber and connect it to the apparatus. Pass the hydrogen (C.2.1) at a flow rate of 500 ml/min through the cold furnace tubes for about 5 min to purge the system of air before heating is commenced. Then raise the temperature of the furnace to 900 °C.

Pass carbon dioxide and hydrogen into the system at an accurately known and steady flow rate (500 ml/min for each gas) for about 2 h with the furnace maintained at 900 °C ± 10 °C.

Note the times at which the determination was begun and ended or expand a known mass of carbon dioxide through the apparatus.

Disconnect the bubbler and close the hydrogen cylinder. Remove the jet of the absorber and wash it with a small volume of water, adding the washings to the remainder of the cadmium chloride solution. By means of the pipette (C.3.9), add 2 ml of the standard volumetric iodine solution (C.2.6) to the bubbler, followed by 2 ml of the concentrated hydrochloric acid (C.2.2). Back titrate the excess iodine with the standard volumetric sodium thiosulfate solution (C.2.5), using the starch solution (C.2.7) as indicator.

C.6 Expression of results

The total sulfur compounds content, expressed as sulfur in parts per million by mass, is given by the formula:

$$320 (2,00 - V)$$

where

V is the volume, in millilitres, of sodium thiosulphate solution used.

NOTE The mass, m_6 , may be obtained by weighing or by calculation using the formula:

$$m_6 = 0,001\ 84 \times A \times t$$

where

m_6 is the mass, in grams, of sample taken;

A is the flow rate, in millilitres per minute, at 20 °C and 1 013 mbar (760 mmHg), of the carbon dioxide;

t is the time of flow, in minutes.

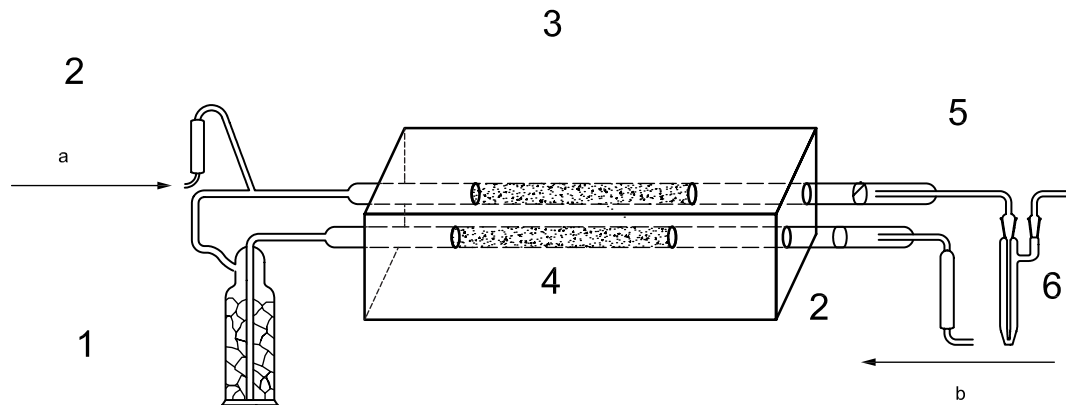

Key

- 1 soda lime
- 2 flow meter
- 3 silica wool packing
- 4 furnace
- 5 silica wool
- 6 absorber
- a Carbon dioxide supply.
- b Hydrogen supply.

Figure C.1 — Apparatus for the determination of total sulfur compounds content

Annex D (informative)

General properties

D.1 Physical properties

A number of the more important physical properties of carbon dioxide are given in Table D.1, for information only.

Table D.1 — Physical properties of carbon dioxide

Property	Value
Relative molecular mass	44
Sublimation point at atmospheric pressure, °C	-78,5
Critical temperature, °C	31
Critical pressure, bar	73,8
Critical volume, m ³ /kg	0,002 15
Critical density, kg/m ³	466,1
Equilibrium vapour pressure at 20 °C, bar	57,3
Vapour density at 20 °C and 1 bar, kg/m ³	1,84
Equilibrium liquid density at 20 °C, kg/m ³	774
Triple point, °C	-56,6
Bar	5,19

D.2 Electrical conductivity

Carbon dioxide complying with the requirements for purity specified in this International Standard has a very low electrical conductivity and can be used to extinguish fires involving live electrical equipment.

D.3 Effects on materials

Carbon dioxide is stable and inert to most common materials.

D.4 Static electricity

In some circumstances, the discharge of carbon dioxide can cause a build-up of static electricity. This can cause sparks which can be hazardous in an explosive atmosphere.

D.5 Toxicology

Information on the toxicology of carbon dioxide is given in Annex G.

Annex E (normative)

Precautions for handling

E.1 Carbon dioxide is shipped from the manufacturer as a liquefied gas in bulk under pressure at low temperature and in cylinders under higher pressure at ambient temperatures.

All precautions pertaining to the safe handling and operation of containers, piping and equipment under pressure should be observed when filling fire fighting equipment with the medium.

E.2 During the discharge of containers of carbon dioxide, low temperatures can arise through expansion of the liquid to gas and solid. This can present a hazard of frost burn. Gloves and eye protection should be worn when transferring carbon dioxide from one container to another.

E.3 Transfer of carbon dioxide should be carried out in a well-ventilated area or in the open air.

E.4 Carbon dioxide is much heavier than air and can collect in pits, cellars and low-lying areas. Care should be taken when entering such areas on sites where carbon dioxide has been used.

Annex F (informative)

Compatibility

Carbon dioxide may be used simultaneously with other types of fire extinguishing media for fire fighting purposes, with no known indications that extinguishing efficiency is affected.

Annex G (informative)

Toxicology

G.1 General

The principal action of carbon dioxide is to cause suffocation, although it is mildly toxic in its own right.

G.2 Precautions and treatment

At concentrations of 3 % to 4 % (VI V) in air, the respiration rate is increased, and this can cause headaches.

At concentrations of 9 % (VI V), personnel can lose consciousness within minutes, this being preceded by disorientation, visual disturbance, ringing in the ears, tremors, etc.

At a concentration of about 20 % (VI V), death will follow in 20 min to 30 min.

In practice, concentrations of 30 % (VI V) or more are employed for total flooding systems. Similarly, high concentrations could be encountered near to the nozzles of hand extinguishers or local application systems. Such concentrations are highly hazardous for persons and special precautions should be taken depending upon the specific conditions of use.

Persons suffering from exposure to carbon dioxide should immediately move or be moved to fresh air. Medical aid should always be sought in the event of such overexposure.

British Standards Institution (BSI)

BSI is the national body responsible for preparing British Standards and other standards-related publications, information and services.

BSI is incorporated by Royal Charter. British Standards and other standardization products are published by BSI Standards Limited.

About us

We bring together business, industry, government, consumers, innovators and others to shape their combined experience and expertise into standards-based solutions.

The knowledge embodied in our standards has been carefully assembled in a dependable format and refined through our open consultation process. Organizations of all sizes and across all sectors choose standards to help them achieve their goals.

Information on standards

We can provide you with the knowledge that your organization needs to succeed. Find out more about British Standards by visiting our website at bsigroup.com/standards or contacting our Customer Services team or Knowledge Centre.

Buying standards

You can buy and download PDF versions of BSI publications, including British and adopted European and international standards, through our website at bsigroup.com/shop, where hard copies can also be purchased.

If you need international and foreign standards from other Standards Development Organizations, hard copies can be ordered from our Customer Services team.

Subscriptions

Our range of subscription services are designed to make using standards easier for you. For further information on our subscription products go to bsigroup.com/subscriptions.

With **British Standards Online (BSOL)** you'll have instant access to over 55,000 British and adopted European and international standards from your desktop. It's available 24/7 and is refreshed daily so you'll always be up to date.

You can keep in touch with standards developments and receive substantial discounts on the purchase price of standards, both in single copy and subscription format, by becoming a **BSI Subscribing Member**.

PLUS is an updating service exclusive to BSI Subscribing Members. You will automatically receive the latest hard copy of your standards when they're revised or replaced.

To find out more about becoming a BSI Subscribing Member and the benefits of membership, please visit bsigroup.com/shop.

With a **Multi-User Network Licence (MUNL)** you are able to host standards publications on your intranet. Licences can cover as few or as many users as you wish. With updates supplied as soon as they're available, you can be sure your documentation is current. For further information, email bsmusales@bsigroup.com.

BSI Group Headquarters

389 Chiswick High Road London W4 4AL UK

Revisions

Our British Standards and other publications are updated by amendment or revision.

We continually improve the quality of our products and services to benefit your business. If you find an inaccuracy or ambiguity within a British Standard or other BSI publication please inform the Knowledge Centre.

Copyright

All the data, software and documentation set out in all British Standards and other BSI publications are the property of and copyrighted by BSI, or some person or entity that owns copyright in the information used (such as the international standardization bodies) and has formally licensed such information to BSI for commercial publication and use. Except as permitted under the Copyright, Designs and Patents Act 1988 no extract may be reproduced, stored in a retrieval system or transmitted in any form or by any means – electronic, photocopying, recording or otherwise – without prior written permission from BSI. Details and advice can be obtained from the Copyright & Licensing Department.

Useful Contacts:

Customer Services

Tel: +44 845 086 9001

Email (orders): orders@bsigroup.com

Email (enquiries): cservices@bsigroup.com

Subscriptions

Tel: +44 845 086 9001

Email: subscriptions@bsigroup.com

Knowledge Centre

Tel: +44 20 8996 7004

Email: knowledgecentre@bsigroup.com

Copyright & Licensing

Tel: +44 20 8996 7070

Email: copyright@bsigroup.com



...making excellence a habit.™