

BS EN ISO 5912:2011



BSI Standards Publication

## Camping tents (ISO 5912:2011)

**bsi.**

...making excellence a habit.™

**National foreword**

This British Standard is the UK implementation of EN ISO 5912:2011. It supersedes BS EN ISO 5912:2005, which is withdrawn. Together with BS ISO 10966:2011, it supersedes BS ISO 10966:2005 which is withdrawn.

The UK participation in its preparation was entrusted to Technical Committee TCI/74, Camping tents.

A list of organizations represented on this committee can be obtained on request to its secretary.

This publication does not purport to include all the necessary provisions of a contract. Users are responsible for its correct application.

© BSI 2011

ISBN 978 0 580 61368 5

ICS 97.200.30

**Compliance with a British Standard cannot confer immunity from legal obligations.**

This British Standard was published under the authority of the Standards Policy and Strategy Committee on 31 October 2011.

**Amendments issued since publication**

Date	Text affected
------	---------------

---

English Version

## Camping tents (ISO 5912:2011)

Tentes de camping (ISO 5912:2011)

Campingzelte (ISO 5912:2011)

This European Standard was approved by CEN on 30 September 2011.

CEN members are bound to comply with the CEN/CENELEC Internal Regulations which stipulate the conditions for giving this European Standard the status of a national standard without any alteration. Up-to-date lists and bibliographical references concerning such national standards may be obtained on application to the CEN-CENELEC Management Centre or to any CEN member.

This European Standard exists in three official versions (English, French, German). A version in any other language made by translation under the responsibility of a CEN member into its own language and notified to the CEN-CENELEC Management Centre has the same status as the official versions.

CEN members are the national standards bodies of Austria, Belgium, Bulgaria, Croatia, Cyprus, Czech Republic, Denmark, Estonia, Finland, France, Germany, Greece, Hungary, Iceland, Ireland, Italy, Latvia, Lithuania, Luxembourg, Malta, Netherlands, Norway, Poland, Portugal, Romania, Slovakia, Slovenia, Spain, Sweden, Switzerland and United Kingdom.



EUROPEAN COMMITTEE FOR STANDARDIZATION  
COMITÉ EUROPÉEN DE NORMALISATION  
EUROPÄISCHES KOMITEE FÜR NORMUNG

**Management Centre: Avenue Marnix 17, B-1000 Brussels**

## Foreword

This document (EN ISO 5912:2011) has been prepared by Technical Committee ISO/TC 83 "Sports and recreational equipment" in collaboration with Technical Committee CEN/TC 136 "Sports, playground and other recreational facilities and equipment" the secretariat of which is held by DIN.

This European Standard shall be given the status of a national standard, either by publication of an identical text or by endorsement, at the latest by April 2012, and conflicting national standards shall be withdrawn at the latest by April 2012.

Attention is drawn to the possibility that some of the elements of this document may be the subject of patent rights. CEN [and/or CENELEC] shall not be held responsible for identifying any or all such patent rights.

This document supersedes EN ISO 5912:2005.

According to the CEN/CENELEC Internal Regulations, the national standards organizations of the following countries are bound to implement this European Standard: Austria, Belgium, Bulgaria, Croatia, Cyprus, Czech Republic, Denmark, Estonia, Finland, France, Germany, Greece, Hungary, Iceland, Ireland, Italy, Latvia, Lithuania, Luxembourg, Malta, Netherlands, Norway, Poland, Portugal, Romania, Slovakia, Slovenia, Spain, Sweden, Switzerland and the United Kingdom.

### Endorsement notice

The text of ISO 5912:2011 has been approved by CEN as a EN ISO 5912:2011 without any modification.

# Contents

Page

Foreword .....	v
<b>0 Introduction.....</b>	<b>vi</b>
<b>0.1 General.....</b>	<b>vi</b>
<b>0.2 Environmental considerations.....</b>	<b>vi</b>
<b>1 Scope.....</b>	<b>1</b>
<b>2 Normative references.....</b>	<b>1</b>
<b>3 Terms and definitions.....</b>	<b>1</b>
<b>4 Classification.....</b>	<b>3</b>
<b>4.1 Categories of camping tents.....</b>	<b>3</b>
<b>4.2 Tent performance level.....</b>	<b>3</b>
<b>5 Calculation of sleeping capacity.....</b>	<b>3</b>
<b>5.1 General.....</b>	<b>3</b>
<b>5.2 Test area 1 for Cat. A tents.....</b>	<b>3</b>
<b>5.3 Test area 2 for Cat. B tents.....</b>	<b>4</b>
<b>6 Requirements.....</b>	<b>4</b>
<b>6.1 General requirements.....</b>	<b>4</b>
<b>6.2 Requirements for components.....</b>	<b>8</b>
<b>7 Tent accessories.....</b>	<b>10</b>
<b>8 Test methods.....</b>	<b>10</b>
<b>8.1 Strength of guying system.....</b>	<b>10</b>
<b>8.2 Corrosion on frame assembly and metal eyelets.....</b>	<b>11</b>
<b>8.3 Rain test.....</b>	<b>11</b>
<b>8.4 Lateral strength of zip fasteners.....</b>	<b>15</b>
<b>8.5 Resistance of plastic sheets to discolouration under the effect of moisture.....</b>	<b>16</b>
<b>8.6 Components tests.....</b>	<b>17</b>
<b>9 Advice to occupants.....</b>	<b>17</b>
<b>10 Information supplied by the manufacturer.....</b>	<b>18</b>
<b>10.1 General.....</b>	<b>18</b>
<b>10.2 Required information.....</b>	<b>18</b>
<b>10.3 Additional information.....</b>	<b>19</b>
<b>11 Marking.....</b>	<b>19</b>
<b>Annex A (informative) Marking of tents.....</b>	<b>20</b>
<b>Annex B (informative) Label for flame retardant materials.....</b>	<b>22</b>
<b>Bibliography.....</b>	<b>23</b>

## Foreword

ISO (the International Organization for Standardization) is a worldwide federation of national standards bodies (ISO member bodies). The work of preparing International Standards is normally carried out through ISO technical committees. Each member body interested in a subject for which a technical committee has been established has the right to be represented on that committee. International organizations, governmental and non-governmental, in liaison with ISO, also take part in the work. ISO collaborates closely with the International Electrotechnical Commission (IEC) on all matters of electrotechnical standardization.

International Standards are drafted in accordance with the rules given in the ISO/IEC Directives, Part 2.

The main task of technical committees is to prepare International Standards. Draft International Standards adopted by the technical committees are circulated to the member bodies for voting. Publication as an International Standard requires approval by at least 75 % of the member bodies casting a vote.

Attention is drawn to the possibility that some of the elements of this document may be the subject of patent rights. ISO shall not be held responsible for identifying any or all such patent rights.

ISO 5912 was prepared by Technical Committee ISO/TC 83, *Sports and recreational equipment*, Subcommittee SC 2, *Camping tents*.

This fourth edition replaces part of ISO 10966:2005 and cancels and replaces the third edition of this International Standard (ISO 5912:2003), which has been technically revised to incorporate the following changes:

- a) inclusion of revised requirements for fabric for camping tents from ISO 10966:2005;
- b) deletion of requirements on stability performance;
- c) introduction of three levels of performance for camping tents;
- d) clarification of consumer information regarding ventilation;
- e) change of test method for flame retardant fabric;
- f) rain test brought into line with industry best practice;
- g) addition of requirements to address risks related to new styles of tents which include squeeze and sheer points;
- h) modification of size of sleeping areas.

## 0 Introduction

### 0.1 General

The principal objective of this International Standard is to simplify it from previous editions by deleting requirements and test methods which did not prove to be reproducible, or which do not contribute to the safety and quality performance of camping tents.

One such deleted parameter was stability performance. Stability was considered to be an important issue for the performance of a tent, however there was no reproducible test method available when developing this International Standard. When a suitable test or simulated test can be developed, it is the intention of ISO/TC 83 to include a more specific requirement in this International Standard.

For marquees and larger textile structures, see Reference [3].

### 0.2 Environmental considerations

Every product affects the environment in the course of its lifecycle from raw material acquisition through production, distribution and use, to disposal. Environmental impacts are consequences of the consumption of energy and resources and the generation of waste, as well as the emission of substances into air, water and soil. The magnitude of the environmental impacts during the various lifecycle changes depends on a number of choices made in the design of the product, such as the materials used, production methods, and considerations related to maintenance and recycling. Manufacturers and distributors of camping tents should consider the environmental impact of their product by, for example:

- avoiding the use of environmentally harmful substances;
- selecting the best available technology and techniques to reduce consumption of energy and materials;
- considering use of recycled materials for product and packaging;
- encouraging responsible end of life disposal by the user including guidance on separation and identification of any recyclable components and packaging;
- using materials, components, and manufacturing facilities which have declared documented environmental policies.





# Camping tents

## 1 Scope

This International Standard specifies requirements for safety, performance and fitness for use of camping tents (referred to as “tents” throughout).

NOTE For caravan awnings, ISO 8936 applies. For terms relating to camping tents and caravan awnings, see ISO 7152.

## 2 Normative references

The following referenced documents are indispensable for the application of this document. For dated references, only the edition cited applies. For undated references, the latest edition of the referenced document (including any amendments) applies.

ISO 105-A02, *Textiles — Tests for colour fastness — Part A02: Grey scale for assessing change in colour*

ISO 105-B04, *Textiles — Tests for colour fastness — Part B04: Colour fastness to artificial weathering: Xenon arc fading lamp test*

ISO 105-X12, *Textiles — Tests for colour fastness — Part X12: Colour fastness to rubbing*

ISO 139, *Textiles — Standard atmospheres for conditioning and testing*

ISO 554, *Standard atmospheres for conditioning and/or testing — Specifications*

ISO 811, *Textile fabrics — Determination of resistance to water penetration — Hydrostatic pressure test*

ISO 2081, *Metallic and other inorganic coatings — Electroplated coatings of zinc with supplementary treatments on iron or steel*

ISO 4675:1990, *Rubber- or plastics-coated fabrics — Low-temperature bend test*

ISO 6925, *Textile floor coverings — Burning behaviour — Tablet test at ambient temperature*

ISO 6941, *Textile fabrics — Burning behaviour — Measurement of flame spread properties of vertically oriented specimens*

ISO 9227, *Corrosion tests in artificial atmospheres — Salt spray tests*

ISO 7771, *Textiles — Determination of dimensional changes of fabrics induced by cold-water immersion*

ISO 13934-2, *Textiles — Tensile properties of fabrics — Part 2: Determination of maximum force using the grab method*

ISO 13937-2, *Textiles — Tear properties of fabrics — Part 2: Determination of tear force of trouser-shaped test specimens (Single tear method)*

EN 388, *Protective gloves against mechanical risks*

## 3 Terms and definitions

For the purposes of this document, the following terms and definitions apply.

### 3.1

#### **base area**

area limited by the outer tent walls which contact the ground

NOTE This area includes awnings and canopies, but excludes area for guy lines, mud walls and snow skirts.

### 3.2

#### **outer tent dimensions**

dimension of the smallest rectangular pitching space required for the tent, excluding guy lines

### 3.3

#### **inner tent area**

part of the base area designated for living and sleeping

### 3.4

#### **inner tent dimensions**

maximum length and the maximum width of the inner tent measured on the ground

### 3.5

#### **sleeping capacity**

number of sleeping berths

### 3.6

#### **minimum usable weight**

weight of the tent including the inner sheet and flysheet (where applicable) plus the minimum number of poles, pegs, and guy lines needed for the tent to be erected and used

NOTE Tent pole bags and peg bags do not need to be included.

### 3.7

#### **total weight**

weight of the tent as supplied, including all poles, fabrics, pegs, bags, etc., excluding packaging

### 3.8

#### **shear and squeeze point**

point at which the distance between two rigid accessible parts moving relative to each other is less than 18 mm and more than 7 mm in any position during movement

### 3.9

#### **accessible shear and squeeze point**

shear and squeeze point to which access can be easily gained when the tent is in its intended configuration for use and for which unintentional contact is foreseeable

### 3.10

#### **automatic locking mechanism**

mechanism which engages without guidance by the user and prevents unintended movement

### 3.11

#### **sealed tent**

tent that has the groundsheet sewn to the flysheet to form a sealed enclosed area, or a tent with a snowskirt

NOTE 1 Tents with snowskirts are not normally sealed tents but there is the possibility of snow or sand building up on these snowskirts which can restrict air circulation, creating a sealed tent.

NOTE 2 The use of a sealed tent can result in a build-up of harmful gases.

### 3.12

#### **snowskirt**

fabric attached to the lower edge of the tent flysheet which is usually designed to sit horizontally on the ground

NOTE This can be covered with snow, or have rocks placed upon it, in order to secure the tent to the ground.

## 4 Classification

### 4.1 Categories of camping tents

#### 4.1.1 Cat. A (lightweight)

Tents having a total weight of  $\leq 2,5$  kg per sleeping berth.

#### 4.1.2 Cat. B

Tents having a total weight of  $> 2,5$  kg per sleeping berth.

### 4.2 Tent performance level

#### 4.2.1 Level 1

Tent designed for infrequent and short-term use. Although rain resistant, these tents should be used mainly in fair weather.

EXAMPLE Occasional summer weekend camping.

#### 4.2.2 Level 2

Tent designed for use in mainly moderate weather conditions.

EXAMPLE Poor (wet and windy) weather conditions; not intended for extreme or mountain conditions.

#### 4.2.3 Level 3

Tent designed for use in all weather conditions.

EXAMPLE Mountaineering, expeditions, snow-loading or extended residential use.

## 5 Calculation of sleeping capacity

### 5.1 General

Sleeping capacity is determined by using test area 1 for Cat. A tents (see 5.2 as well as Table 1 and Figure 1) and test area 2 for Cat. B tents (see 5.3) and establishing how many times this test area can be fitted into the sleeping area without overlapping or deforming the fabric of the tent.

### 5.2 Test area 1 for Cat. A tents

Test area is measured at a height of 5 cm.

**Table 1 — Dimensions of test area 1**

Dimensions in centimetres

$l_1$	$l_2$	$l_3$	$l_4$	$l_5$
35	30	195	35	58

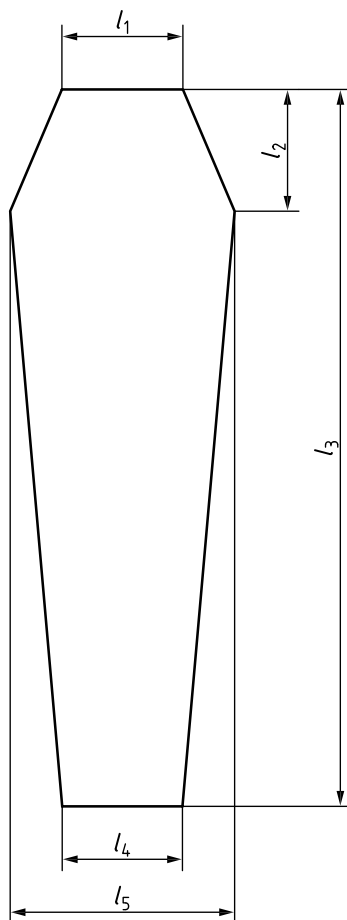

Figure 1 — Test area 1

### 5.3 Test area 2 for Cat. B tents

Rectangular test area: 200 cm × 60 cm, height 5 cm.

## 6 Requirements

### 6.1 General requirements

#### 6.1.1 Fabrics and their connections

##### 6.1.1.1 Tear resistance, breaking strength, resistance to penetration by water, weatherability

Fabrics and their connections shall meet the requirements specified in Table 2.

Table 2 — Requirements for fabrics and their connections

		Cat. A			Cat. B		
		Level 1	Level 2	Level 3	Level 1	Level 2	Level 3
<b>Tear resistance according to ISO 13937-2<sup>a</sup></b> N	outer tent, coated	10	10	15	10	15	20
	outer tent, uncoated	10	10	15	15	20	25
	inner tent	8	8	12	8	9	13
	groundsheet	12	12	15	12	15	20
<b>Breaking strength according to ISO 13934-2<sup>a</sup></b> N	outer tent, coated	250	300	400	300	400	500
	outer tent, uncoated	250	300	400	300	400	500
	inner tent	150	200	300	200	300	400
	groundsheet	250	300	400	300	400	500
	plastic windows	100	150	200	100	150	200
<b>Resistance to penetration by water according to ISO 811<sup>ab</sup></b> kPa	outer tent, coated	15	15	25	15	20	30
	groundsheet	15	30	50	15	30	50
<b>Weatherability according to ISO 105-B04<sup>a</sup></b> (measured against blue wool)	outer tent, coated	3	3-4	4	3	3-4	4
	outer tent, uncoated	3	3-4	4	3	3-4	4
	plastic windows	3	3-4	4	3	3-4	4
<b>Colour fastness according to ISO 105-X12<sup>a</sup></b> (wet test)	outer tent, coated	3-4	4	5	3-4	4	5
	outer tent, uncoated	3-4	4	5	3-4	4	5
	inner tent	3-4	4	5	3-4	4	5
	groundsheet	3-4	4	5	3-4	4	5
	plastic windows	3-4	4	5	3-4	4	5
<b>Resistance to puncture according to EN 388<sup>a</sup></b> N	groundsheet	10	15	15	10	15	20

Table 2 (continued)

		Cat. A			Cat. B		
		Level 1	Level 2	Level 3	Level 1	Level 2	Level 3
<b>Resistance to cold crack according to ISO 4675:1990, 9.1.</b>  Test temperature shall be $-5\text{ }^{\circ}\text{C}$ (performance level 2) and $-10\text{ }^{\circ}\text{C}$ (performance level 3).	Plastic windows	—	Cracks of grade A acceptable	Cracks of grade A acceptable	—	Cracks of grade A acceptable	Cracks of grade A acceptable
NOTE Manufacturers of products complying with this International Standard should consider the health and protection of the user, the environment and the supply chain. Materials used should not, during foreseeable conditions of normal use, release or degrade to release substances generally known to be hazardous and should comply with national legislation for such substances.							
<sup>a</sup> If not stated otherwise, the tests shall be carried out at standard atmosphere in accordance with ISO 139.							
<sup>b</sup> 1 kPa = 1 000 Pa = 10 mbar = 101,971 62 mmH <sub>2</sub> O = 10,197 162 cmH <sub>2</sub> O.							

### 6.1.1.2 Dimensional stability

When tested in accordance with ISO 7771 using a cycle of 2 h, the dimensional change shall not exceed  $\pm 3\%$ .

### 6.1.1.3 Flammability

#### 6.1.1.3.1 General

If the fabrics of a camping tent are claimed to have flame retardant properties they shall be tested when new and shall comply as required to 6.1.1.3.2, 6.1.1.3.3 and 6.1.1.3.4. See Table 2, Note 1 for information about the use of applied chemical finishes to produce flame retardant properties.

#### 6.1.1.3.2 Outer tent material

When tested in accordance with ISO 6941:2003, Procedure A (using a 10 s ignition time, surface ignition), no marker threads shall be severed, there shall be no flaming debris, there shall be no flame to either vertical edge of the test specimen, no single sample shall show afterflame time exceeding 10 s, and the average afterflame time shall not exceed 6 s.

#### 6.1.1.3.3 Inner tent material

When tested in accordance with ISO 6941, Procedure A (using a 10 s ignition time, surface ignition), no marker threads shall be severed, there shall be flaming debris on no more than two of the tested samples, there shall be no flame to either vertical edge of the test specimen, no single sample shall show afterflame exceeding 20 s, and the average afterflame time shall not exceed 12 s. Should a single sample fail, the test shall be repeated once more; if the fabric fails a second time then the fabric is deemed to have failed the test.

#### 6.1.1.3.4 Groundsheet

When tested in accordance with ISO 6925, the radius of burn shall be less than 35 mm.

### 6.1.2 Ground fastening

At least one ground fastening shall be provided for each corner, or four ground fasteners as a minimum if the tent is not rectangular.

### 6.1.3 Protective measures

Points on the groundsheet which are in contact with frame parts shall be suitably protected.

### 6.1.4 Ventilation

#### 6.1.4.1 General

In order to reduce the risk of suffocation, tents shall be designed to maintain a circulation of air and minimize the opportunity for a build-up of harmful gases to dangerous levels within the sleeping areas.

NOTE See Clause 9 for warning label information.

#### 6.1.4.2 Sealed tents

In order to provide a sufficient circulation of air, a minimum of two ventilation openings shall be provided, each of which shall be at least 100 cm<sup>2</sup> per person. These openings shall be of such a design that when opened they cannot be closed by prevailing weather conditions.

NOTE In order to allow a suitable circulation of fresh air and to prevent a build-up of carbon dioxide in the lower areas of the tent, it is recommended that one of these vents be placed less than 1/3 of the total height of the tent from the ground, and the other placed in the upper 1/3 of the height of the tent. In the case of double skin tents, an area of 2/3 of the inner tent excluding the groundsheet should be made from an air permeable material.

#### 6.1.4.3 Double skin tents

By choosing suitable materials and product design, a permanent circulation of air to reduce condensation shall be possible.

### 6.1.5 Tent exits

Tents with a sleeping capacity of four or more persons shall have an exit with a minimum area of 0,9 m<sup>2</sup> and a minimum width of 50 cm. Where two exits are provided, this size requirement only applies to the first.

Tent exits may be closed using a zip fastener (see 6.2.2) or any other system, provided that they can be opened easily from the bottom, if the exit is higher than 100 cm.

NOTE This provides an escape route for children.

### 6.1.6 Insect protection

Doors and openings for inner tents shall be insect-proof when they are closed.

Insect resistant nets, if used, shall have a maximum mesh size of 1 mm × 1 mm.

### 6.1.7 Resistance to penetration by rain

The resistance of the tent shall be such that no water penetrates the tent interior except a light mist during the first 2 min, when the rain test according to 8.3 is carried out.

The outer fabric of the tent shall not come into contact with the inner fabric unless designed to do so, e.g. pole sleeves of geodesic tents (see Figure 2).

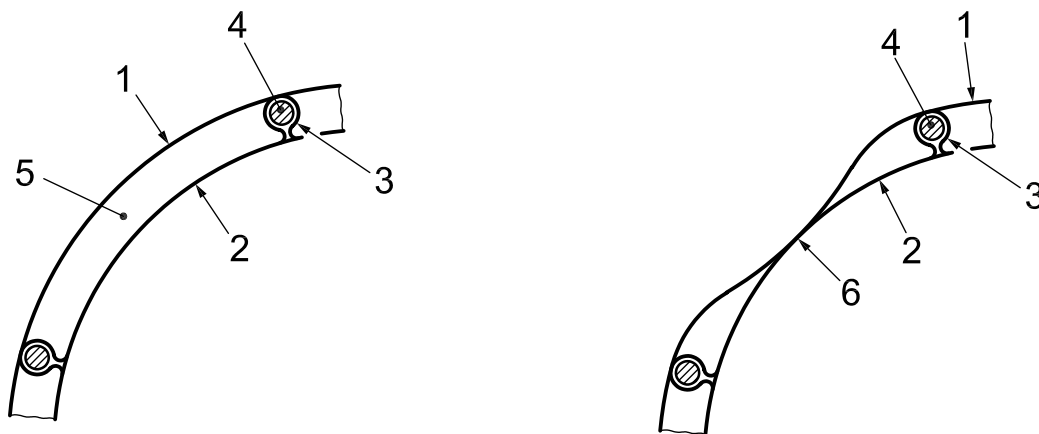

a) Correct assembly of inner and outer fabric      b) Incorrect assembly of inner and outer fabric

**Key**

- |   |              |   |  |
|---|--------------|---|--|
| 1 | outer fabric | 4 | frame  |
| 2 | inner fabric | 5 | required distance of outer fabric to inner fabric      |
| 3 | eyelets      | 6 | unacceptable contact of outer fabric with inner fabric |

**Figure 2 — Assembly of outer and inner fabric**

If the fabric requires a pre-conditioning (due to soaking behaviour of seams) it shall be made according to 8.3. If additional preparation work (e.g. seam sealing) is recommended by the manufacturer, it should be carried out in accordance with information supplied by the manufacturer.

**6.2 Requirements for components**

**6.2.1 Frame**

**6.2.1.1 General**

All metal parts shall be such that there is no change at the end of the test according to 8.2, except for minor discolouration. In the case of enamelled or coated frame components, there shall be no infiltration under the varnish of more than 0,5 mm according to ISO 9227.

The frame parts shall be clearly marked to facilitate the pitching. The only exception to this would be if the frame parts for a tent can only be assembled in one form or if a detailed construction plan is available.

If two frame components are fitted together, the lower component shall not become detached when subjected to twice its own weight in a vertical position.

The tubular connection of the frame components to be fitted together shall have a minimum length of two times the outside diameter.

**6.2.1.2 Edges and corners**

Edges and corners accessible during assembly and use shall be free from burrs and/or sharp edges. Test in accordance with 8.6.1.

**6.2.1.3 Tubular components, holes and gaps**

Tubular components, holes and gaps accessible during pitching, striking and use shall be covered if a 7 mm or 12 mm test probe can be pushed into them in any direction to a depth of more than 10 mm when tested in accordance with the requirements in 8.6.2.



#### 6.2.1.4 Shear and squeeze points

Shear and squeeze points that are created only during setting up or folding are acceptable, providing that the user can be assumed to be in control of his/her movements and to be able to cease applying the force immediately on experiencing pain. The edges of shear and squeeze points shall be rounded or chamfered.

There shall be no accessible shear and squeeze points created by parts of the frame assembly operated by mechanical mechanisms, e.g. mechanical springs, gas lifts.

There shall be no accessible shear or squeeze points created by loads applied during normal use (this hazard is best prevented by the use of automatic locking systems).

Test in accordance with 8.6.3.

#### 6.2.2 Zip fasteners

##### 6.2.2.1 General

The slider shall not be the same colour as the teeth and ribbon of the zip, unless a conspicuous handle of a different colour is attached to the slider.

In order to open the doors from inside and outside independently, the zip fasteners of doors shall have double tagged sliders.

##### 6.2.2.2 Lateral strength of zip fasteners

The lateral strength of zip fasteners shall be in accordance with the values in Table 3.

**Table 3 — Lateral strength of zip fasteners**

		Cat. A			Cat. B		
		Level 1 [N]	Level 2 [N]	Level 3 [N]	Level 1 [N]	Level 2 [N]	Level 3 [N]
Lateral strength of zip fasteners	Outer tent	200	250	300	250	300	350
	Inner tent	150	200	250	200	250	300

Test in accordance with 8.4.

#### 6.2.3 Guying system

The individual guying assembly including eyelets, lower and upper attachments and tensioning device shall withstand a minimum tensile force according to Table 4. Test in accordance with 8.1.

**Table 4 — Strength of guying system**

	Cat. A			Cat. B		
	Level 1 [N]	Level 2 [N]	Level 3 [N]	Level 1 [N]	Level 2 [N]	Level 3 [N]
Strength of the guying system	250	300	350	300	350	400

For resistance to corrosion of metal eyelets, see 6.2.1.1.

#### 6.2.4 Tent and pole bags

At least one bag shall be supplied for the tent.

The characteristics of the material used for the bag shall be at least in accordance with the specifications for fabrics for outer tents (coated/uncoated) given in Table 2, except for resistance to penetration by rain.

Separate bags shall be supplied for the frame assembly and the pegs, where applicable.

## **7 Tent accessories**

The tent shall be supplied with sufficient tent accessories to ensure the performance of the tent in accordance with this International Standard.

## **8 Test methods**

### **8.1 Strength of guying system**

Assemble and pitch the tent according to the instructions supplied by the manufacturer and close the tent doors and windows.

Dismantle a guy and apply a tensile force according to Table 4 for the respective performance level of the Cat. A or Cat. B camping tent on the guying system for 1 min in the direction of the ground fastening (see Figure 3).

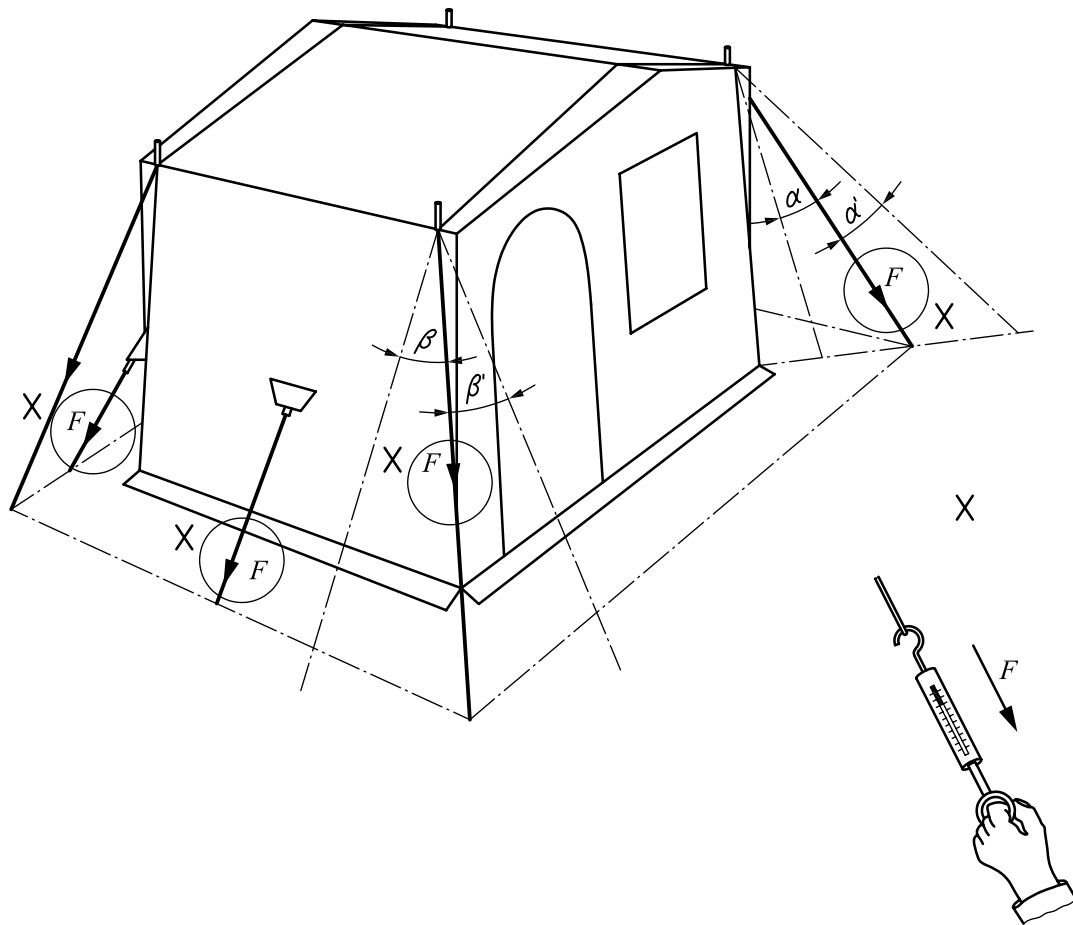

**Key**

- $\alpha/\alpha'$  angle of deflection of the guy (parallel to the usual position of the ground fastening)
- $\beta/\beta'$  angle of deflection of the guy (rectangular to the usual position of the ground fastening)
- $F$  force

**Figure 3 — Strength test of the guying system**

Re-assemble the guy afterwards. The test shall be repeated for each individual style of attachment points provided on the tent.

**8.2 Corrosion on frame assembly and metal eyelets**

Subject the framework to a 36 h neutral salt spray (NSS) test in accordance with ISO 9227, or to a 192 h test for basis metal corrosion (red rust) in accordance with ISO 2081.

**8.3 Rain test**

**8.3.1 General**

To test the requirements of 6.1.7, the procedure as given in 8.3.2, 8.3.3 and 8.3.4 shall be followed.

**8.3.2 Preconditioning and preparation**

Where instructions provided with the tent indicate seam sealing by the consumer is required prior to use, this shall be completed following the manufacturer's instructions.

Tents composed of an uncoated outer material shall be subjected to a pre-treatment process consisting of a single rain test and a subsequent drying period of a minimum of 24 h in ambient conditions.

NOTE It is recognized that due to local conditions and weather at the time of testing, the drying period might be longer than 24 h.

### 8.3.3 Essential test requirements and test installation

The tent shall be tested on water permeable ground, e.g. a lawn or synthetic turf surface with suitable drainage to avoid water pooling around the tent openings.

Water may be recycled for water conservation purposes. However, care should be taken to ensure re-used water does not contain any impurities which can block the spray system.

Water pressure shall be 300 kPa to 450 kPa. Water shall be evenly sprinkled over the test area from a height of 4,5 m to 5 m above the ground. The water flow rate shall be a minimum of 60 l/(h·m<sup>2</sup>) over the test area. A pumped water system consisting of a ring main or similar is acceptable to achieve the desired pressure, flow rate and evenness of application.

Sprinklers shall be designed to provide even and uniform coverage of the test area, either by means of oscillation as in Figure 4 or by their position in a grid formation or other overhead manner as in Figure 5.

NOTE 1 A specific sprinkler "hole" size is not specified, as holes are not generally used to deliver the water from overhead sprinkler systems.

Rain formation should be in the form of a shower of droplets, not large drops, as long periods of medium rainfall are more likely to penetrate openings in use than heavy storms which tend to cause ingress by poor drainage or badly located tents.

Test installations and equipment may be of varying designs, providing the criteria detailed in this subclause are met. It has been found that static installations with side sprinklers as shown in Figure 4 are suitable, as are other designs which achieve the necessary key criteria, e.g. test installations based on overhead sprinkler systems such as those used for building fire sprinkler systems (see Figure 5).

In addition, suitable test installations may rely where necessary on manual rotation of the tent to ensure different entrances face the sprinkler systems, or on relocation of the sprinkler systems themselves, or an intermittent mechanical rotational system for the tent, or a fully automatic continual rotational system for the tent.

NOTE 2 For large tents, manual rotation of the tent itself to face different openings to sprinkler systems such as those in Figure 4 might be impractical due to the weight of the tent while wet and problems with correct re-erection. Relocating the sprinklers might be more practical.

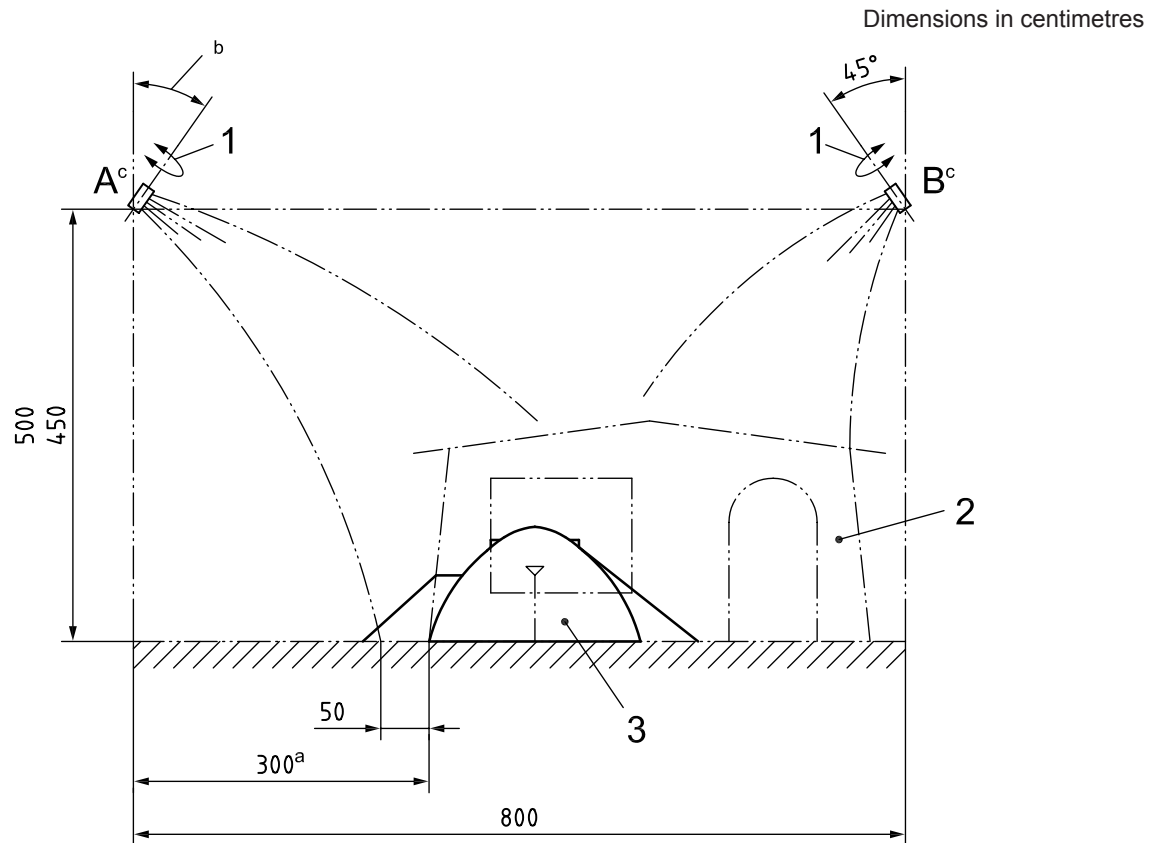

**Key**

- 1 swivelling motion
- 2 large tent after turning the entrance through about 90° away from sprinkler A
- 3 small tent placed with entrance facing sprinkler A
- A swivelling sprinkler with adjustable inclination capable of swivelling up to 90° maximum (45° each side across the centre line A-B)
- B swivelling sprinkler with fixed inclination capable of swivelling up to 90° maximum (45° each side across the centre line A-B)

**NOTE** Adjustable angle of inclination of sprinklers allows correct positioning of the spray area at a distance of 50 cm in front of the outer edge of the side of the tent facing the sprinkler.

<sup>a</sup> For tents with a width >500 cm, the dimension of 300 cm is reduced when the wide side of the tent is placed in direction A-B.

<sup>b</sup> Adjustable inclination.

<sup>c</sup> Both sprinklers shall be fitted with a rose-type spray head capable of delivering the required water volume in the form of a shower of droplets.

**Figure 4 — Example of one suitable form of static test installation using an oscillating side sprinkler system**

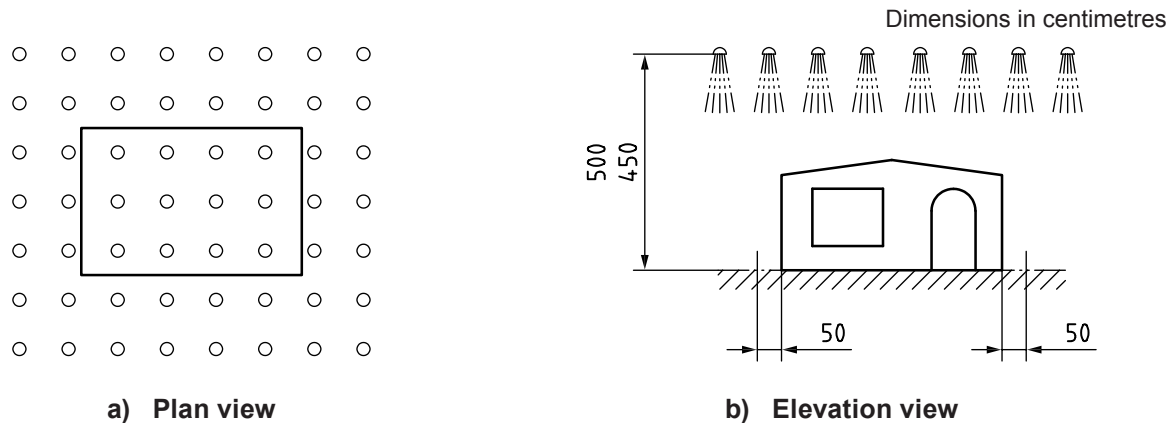

**Figure 5 — Example of one suitable form of static installation using an overhead grid sprinkler system**

### 8.3.4 Test procedure

Pitching of the tent shall be in accordance with manufacturer's instructions. Ventilation points shall be left open as instructed for use and doors shall be closed for the duration of the test.

All different types of entrances, ventilation points or openings shall be subjected to the rain test.

The water shall be applied in such a way as to fall onto both the roof area of the tent (including any ventilation openings) down the sides of the tent, and at least a minimum distance of 50 cm beyond the dimensions of the outer tent and any porch, or extension onto the ground (see Figures 4 and 5).

If the test installation is designed such that the whole tent is tested at once (e.g. as in Figure 5 using an overhead spray system on a static or fully automatic rotational base), the complete test time shall be 30 min.

If the test installation is designed such that the tent can only be tested in sections, such as in Figure 4, and the tent is to be rotated manually or in a semi-automatic fashion, then the main entrance shall be tested facing sprinkler A in Figure 4 for 15 min. The tent shall then be rotated approximately 90° and tested for a further 15 min, thus a minimum of 30 min, and any additional entrances, ventilation points or openings of different designs shall also be tested facing sprinkler A in Figure 4 for 15 min each.

For fully automatic rotational test installations with rain being presented by side sprinklers rather than fully overhead sprinklers, the total test period shall be a minimum of 30 min, plus an additional 15 min for each type of entrance, opening or ventilation point.

Testing shall be carried out at ambient temperature.

**NOTE** It is recognized this will vary due to the location of the test and the time of year. However, the volume of water and type of spray applied to the tent are the important parameters for this test.

Following completion of the test, leave the tent for 2 min to allow excess water to drain from the vicinity of the doors before opening them to examine any ingress.

The report shall include reference to any dampness or water on inner surfaces, pooling of water on the floor of the tent, or similar issues including location and severity.

For tents which are rotated manually to perform the test, inspection shall occur at the end of each 15 min increment in order that the point of ingress can be correctly identified.

In addition, the type of installation used shall be described including details such as the manual rotation of the tent, relocation of the sprinkler systems, mechanical discontinuous rotational system, or fully automatic continual rotational system.

## 8.4 Lateral strength of zip fasteners

### 8.4.1 Lateral strength of the zip fastener

The velocity at which the clamps (see Figure 6) withdraw from each other is 15 cm/min. Prior to testing, the zip fastener shall be conditioned in the measuring atmosphere for at least 48 h.

Dimensions in centimetres

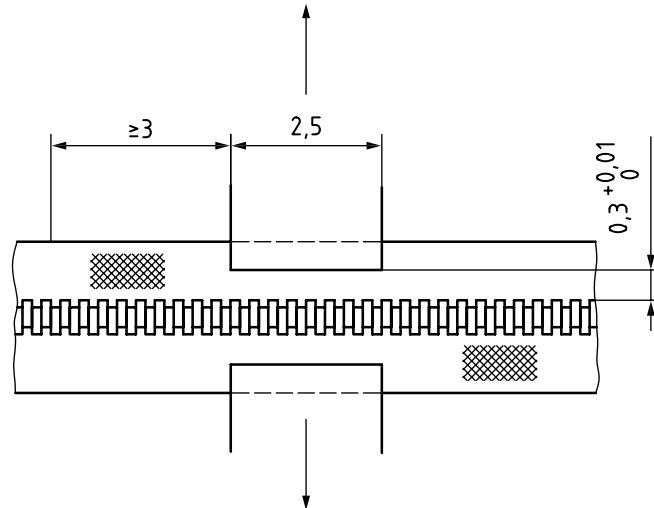

Figure 6 — Stretching to determine the maximum lateral strength

### 8.4.2 Behaviour of the zip fastener under conditions of continuous reciprocating movement

Testing of behaviour under conditions of continuous reciprocating movement shall be carried out by a device as shown in Figure 7.

Apply a force,  $F_1$ , in the lateral direction and a force,  $F_2$ , in the longitudinal direction, to the tapes on both sides, half way between the two extreme ends of the slide.

$$F_1 = 3 \times w$$

$$F_2 = 2 \times w$$

where

$F_1$  is force in lateral direction, expressed in newtons;

$F_2$  is force in longitudinal direction, expressed in newtons;

$w$  is width of the zip fastener, expressed in millimetres.

NOTE Only the value, not the dimension, of  $w$  is used as a multiplier.

Set and apply the test loads with the slider on the zip fastener, at the bottom end, and do not change them during the test.

Ensure that the opening angle of the slider tab is approximately  $30^\circ$  at the upper point of reversal and approximately  $60^\circ$  at the lower point of reversal. When opening,  $F_1$  may be zero.

Open and close the zip fastener 200 times by moving the slider over a length of traverse of 7,5 cm, a to-and-fro movement being designated as a stroke, at a test velocity of 30 strokes/min.

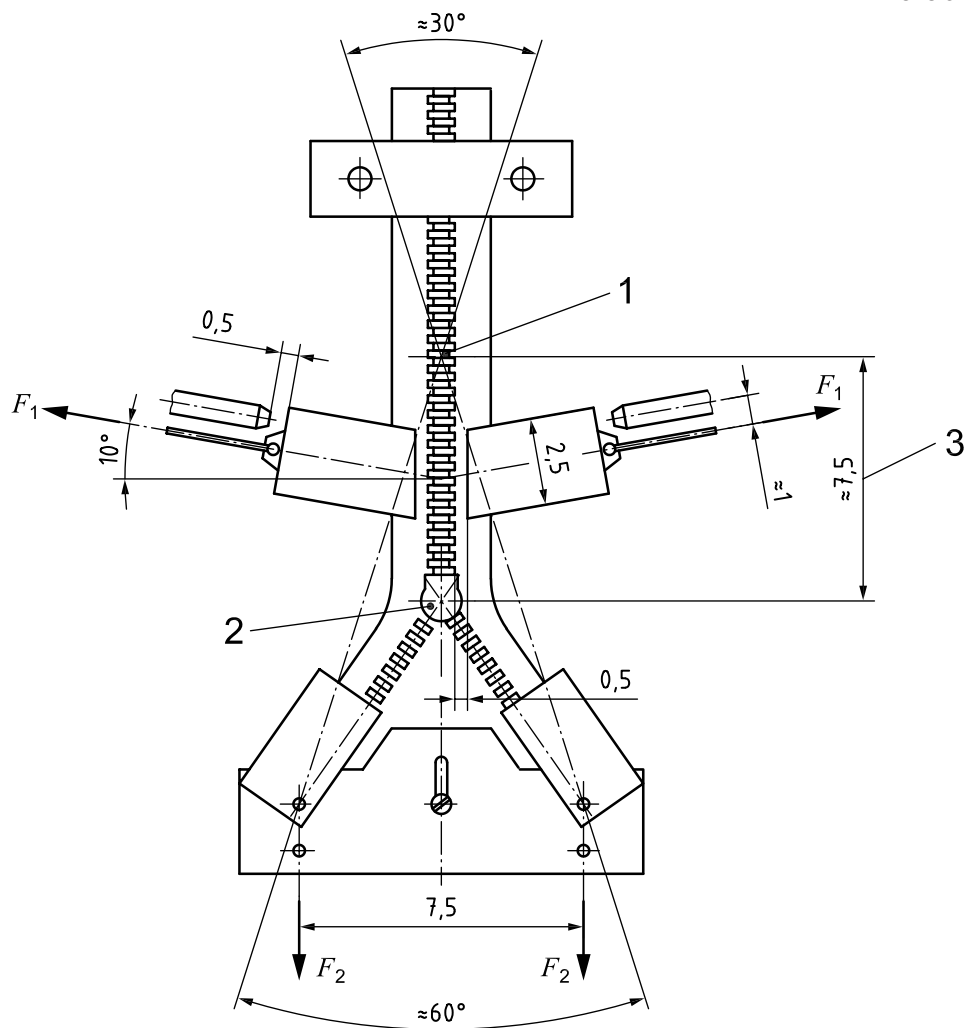

**Key**

- 1 upper point of reversal
- 2 lower point of reversal
- 3 test length
- $F_1$  force in lateral direction
- $F_2$  force in longitudinal direction

**Figure 7 — Device for the reproducible simulation of a load situation at the zip fastener**

Subsequent to this pre-loading, the maximum lateral strength of the zip fastener shall be determined in accordance with 8.4.1.

**8.5 Resistance of plastic sheets to discolouration under the effect of moisture**

Expose the plastic sheets to weathering in accordance with ISO 105-B04 for 24 h. Afterwards, store the sample at standard atmosphere in accordance with ISO 554 for 24 h. Evaluate a possible discolouration on the basis of the grey scale for the assessment of colour changes (in accordance with ISO 105-A02).



## 8.6 Components tests

### 8.6.1 Edges and corners

Inspect all types of components visually and by hand for the presence of any sharp corners and edges.

### 8.6.2 Tubular components, holes and gaps

Check whether a 7 mm or 12 mm test probe (see Figure 8) can be pushed in any direction to a depth of >10 mm into any tubular components, holes and gaps accessible during pitching, striking and use using a maximum insertion or removal force of 30 N.

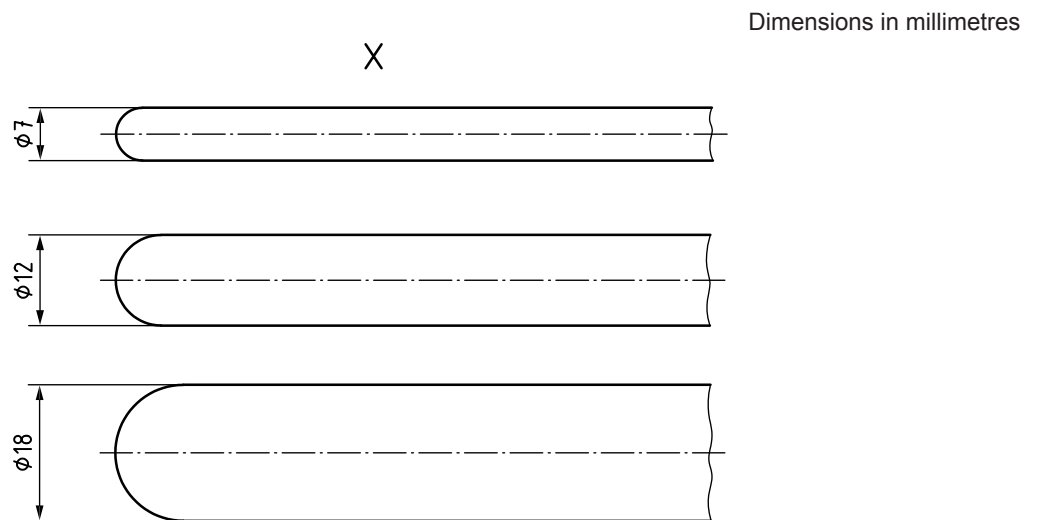

Figure 8 — Test probe

### 8.6.3 Shear and squeeze points

Assemble the tent in accordance with the instructions supplied by the manufacturer and ensure that there are no accessible shear and squeeze points created by parts of the frame assembly operated by mechanisms, such as mechanical springs, gas lifts, or by loads applied during normal use.

Inspect the edges of any shear and squeeze points visually and by hand to ensure they are rounded or chamfered.

Where automated locking systems are used, ensure that they prevent the creation of any shear and squeeze points which might be created by loads applied during normal use.

## 9 Advice to occupants

A permanent legible notice, at least in one of the official languages of the country of sale, giving simple fire prevention and ventilation advice shall be attached inside the tent in a position where it can be easily and readily seen.

The minimum dimensions of the notice shall be 6 cm × 13 cm for each language.

The letters for the heading “Fire and ventilation precautions” shall be at least twice as high as the letters for the remainder of the text.

The heading shall be in red letters, the remainder of the text shall be black on a white background.

The following wording and layout shall be used:

### Fire and ventilation precautions

Caution:

- If using gas or other combustion appliances additional ventilation is required
- Do not place hot appliances near the walls, roof or curtains
- Always observe the safety instructions for these appliances
- Never allow children to play near hot appliances
- Keep exits clear
- Make sure you know the fire precaution arrangements on the site
- Make sure ventilation openings are open all the time to avoid suffocation

If the fabric of a camping tent is claimed to have flame retardant properties, a relevant warning shall be attached inside the tent in a position where it can be easily and readily seen (see Annex B). The minimum dimensions of the notice shall be 5 cm × 8 cm for each language.

## 10 Information supplied by the manufacturer

### 10.1 General

Each tent shall be accompanied by instructions for use with explanatory sketches or drawings.

This information may be provided either with the tent attached to its stuff bag or in a brochure or on a DVD. In particular, these instructions shall ensure that the pitching and maintenance can be easily understood by a novice user.

### 10.2 Required information

Instructions for use shall at least contain information about the following items.

- a) Pitching/striking/repacking:
  - information concerning the marking of the frame assembly,
  - order of pitching/striking/repacking,
  - fastening, storm guys,
  - packing of wet tents (consequences).
- b) Behaviour in the event of fire/means of escape.
- c) Advice on the importance of ventilation and how to adjust it:
  - use of gas or other combustion appliances,
  - importance of maintaining a high level of ventilation by keeping ventilation points clear.
- d) Dimensions:
  - if a tent is described as a tent with a standing height, it shall be at least 185 cm high at some point inside the tent,
  - inner tent dimensions, in cm,

- outer tent dimensions, in cm,
- pitching dimensions, in cm.

### 10.3 Additional information

Instructions for use may contain additional information about the following items.

- a) Maintenance/repair:
  - cleaning, spot removal,
  - storage,
  - repair of minor leaks,
  - reproofing,
  - maintenance of zip fasteners and frame assembly,
  - repair of broken frame parts,
  - repair of damage to fabrics and plastic sheets.
- b) Trial pitching of the tent (to get used to the design).
- c) Choice of site and issues with different ground and weather conditions:
  - type of ground, e.g. snow, sandy soil,
  - prevailing wind direction and particular environmental conditions.

## 11 Marking

**11.1** Tents shall be marked with the name or trademark of the manufacturer, supplier or importer.

**11.2** Tents conforming to this International Standard shall be marked in such a way that the consumer, when buying a tent, is able to recognize essential data concerning the tent, including the level of material performance specified in Table 2. The marking should preferably be in accordance with the examples given in Table A.1 and Table A.2. At the top of the marking the explanation of the level as given in 4.2 shall be included.

In order for a particular component (outer tent, inner tent, groundsheet) to be labelled as having flame retardant properties, over 75 % of the area in question shall be made of the flame retardant material.

Where indications are made in relation to flame retardant performance, based on the appropriate testing and areas of use of flame retardant materials, the manufacturer shall indicate which component parts are flame retardant, e.g. outer tent, inner tent, groundsheet (see Annex B).

**11.3** The manufacturer may indicate that tents conform to the requirements of this International Standard by adding a reference to ISO 5912.

## Annex A (informative)

### Marking of tents

#### A.1 Cat. A camping tents (lightweight)

The figures and material data given as examples in Table A.1 serve only as an illustration of the described type.

**Table A.1 — Marking of Cat. A camping tents (performance level 3)**

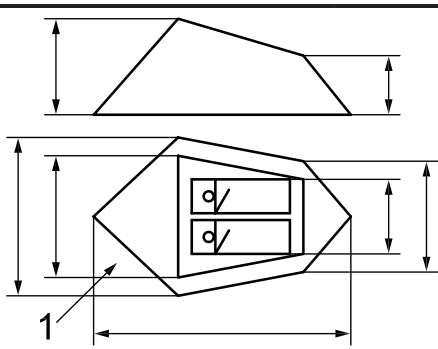
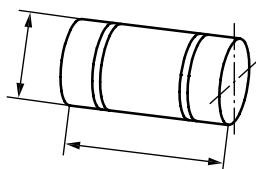
Cat. A camping tent in accordance with ISO 5912 (performance level 3: for use in all weather conditions)			
Sleeping capacity, base area, inner tent area and outer tent dimensions  Standing height	 <p style="margin-top: 10px;"><b>Key</b> 1 entrance</p>		
Packing dimensions  Packing weight (total weight/ minimum usable weight)		..... kg	Divisible into ..... parts of ..... kg or non-divisible
Material:  Outer tent  Inner tent  Groundsheet	100 % polyester, coated  100 % cotton  100 % polyethylene		
Manufacturer/importer			

#### A.2 Cat. B camping tents

The figures and material data given as examples in Table A.2 serve only as an illustration of the described type.

**Table A.2 — Marking of Cat. B camping tents (performance level 2)**

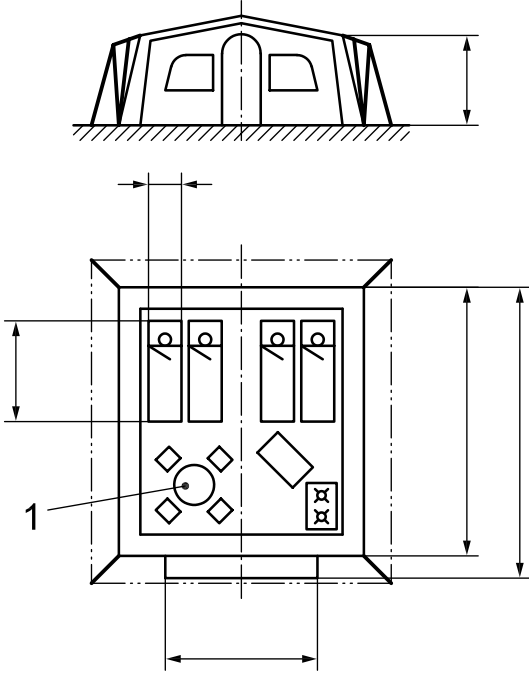
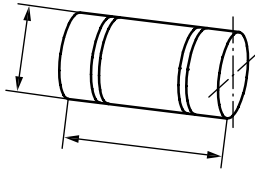
Cat. B camping tent in accordance with ISO 5912 (performance level 2: for use in mainly moderate weather conditions; suitable for use in poor, e.g. wet and windy, weather conditions, but not intended for extreme or mountain conditions)			
<p>Sleeping capacity, living area with furniture <sup>a</sup>, base area, inner tent area and outer tent dimensions</p> <p>Standing height</p>	 <p><b>Key</b></p> <p>1 furniture</p>		
<p>Packing dimensions</p> <p>Packing weight (total weight/minimum usable weight)</p>		<p>..... kg</p>	<p>Divisible into ..... parts or non-divisible</p>
<p>Material:</p> <p>Outer tent</p> <p>Inner tent</p> <p>Groundsheet</p>	<p>100 % polyester, coated</p> <p>100 % cotton</p> <p>100 % polyethylene</p>		
<p>Manufacturer/importer</p>			
<p><sup>a</sup> Marking of furniture is optional.</p>			

## **Annex B** (informative)

### **Label for flame retardant materials**

#### **Flame retardant precautions**

**WARNING:** Keep all flame and heat sources away from this tent fabric.

The [outer tent/inner tent/groundsheet] meets the flammability requirements of ISO 5912. The fabric may burn if left in continuous contact with any flame source. The flame retardant properties will diminish with use over a period of time. The application of any foreign substance to the tent fabric may render the flame-retardant properties ineffective.

## Bibliography

- [1] ISO 7152, *Camping tents and caravan awnings — Vocabulary and list of equivalent terms*
- [2] ISO 8936, *Awnings for leisure accommodation vehicles — Requirements and test methods*
- [3] EN 15619:2008+A1:2010, *Rubber or plastic coated fabrics — Safety of temporary structures (tents) — Specification for coated fabrics intended for tents and related structures*







# British Standards Institution (BSI)

BSI is the national body responsible for preparing British Standards and other standards-related publications, information and services.

BSI is incorporated by Royal Charter. British Standards and other standardization products are published by BSI Standards Limited.

## About us

We bring together business, industry, government, consumers, innovators and others to shape their combined experience and expertise into standards-based solutions.

The knowledge embodied in our standards has been carefully assembled in a dependable format and refined through our open consultation process. Organizations of all sizes and across all sectors choose standards to help them achieve their goals.

## Information on standards

We can provide you with the knowledge that your organization needs to succeed. Find out more about British Standards by visiting our website at [bsigroup.com/standards](http://bsigroup.com/standards) or contacting our Customer Services team or Knowledge Centre.

## Buying standards

You can buy and download PDF versions of BSI publications, including British and adopted European and international standards, through our website at [bsigroup.com/shop](http://bsigroup.com/shop), where hard copies can also be purchased.

If you need international and foreign standards from other Standards Development Organizations, hard copies can be ordered from our Customer Services team.

## Subscriptions

Our range of subscription services are designed to make using standards easier for you. For further information on our subscription products go to [bsigroup.com/subscriptions](http://bsigroup.com/subscriptions).

With **British Standards Online (BSOL)** you'll have instant access to over 55,000 British and adopted European and international standards from your desktop. It's available 24/7 and is refreshed daily so you'll always be up to date.

You can keep in touch with standards developments and receive substantial discounts on the purchase price of standards, both in single copy and subscription format, by becoming a **BSI Subscribing Member**.

**PLUS** is an updating service exclusive to BSI Subscribing Members. You will automatically receive the latest hard copy of your standards when they're revised or replaced.

To find out more about becoming a BSI Subscribing Member and the benefits of membership, please visit [bsigroup.com/shop](http://bsigroup.com/shop).

With a **Multi-User Network Licence (MUNL)** you are able to host standards publications on your intranet. Licences can cover as few or as many users as you wish. With updates supplied as soon as they're available, you can be sure your documentation is current. For further information, email [bsmusales@bsigroup.com](mailto:bsmusales@bsigroup.com).

## BSI Group Headquarters

389 Chiswick High Road London W4 4AL UK

## Revisions

Our British Standards and other publications are updated by amendment or revision.

We continually improve the quality of our products and services to benefit your business. If you find an inaccuracy or ambiguity within a British Standard or other BSI publication please inform the Knowledge Centre.

## Copyright

All the data, software and documentation set out in all British Standards and other BSI publications are the property of and copyrighted by BSI, or some person or entity that owns copyright in the information used (such as the international standardization bodies) and has formally licensed such information to BSI for commercial publication and use. Except as permitted under the Copyright, Designs and Patents Act 1988 no extract may be reproduced, stored in a retrieval system or transmitted in any form or by any means – electronic, photocopying, recording or otherwise – without prior written permission from BSI. Details and advice can be obtained from the Copyright & Licensing Department.

## Useful Contacts:

### Customer Services

**Tel:** +44 845 086 9001

**Email (orders):** [orders@bsigroup.com](mailto:orders@bsigroup.com)

**Email (enquiries):** [cservices@bsigroup.com](mailto:cservices@bsigroup.com)

### Subscriptions

**Tel:** +44 845 086 9001

**Email:** [subscriptions@bsigroup.com](mailto:subscriptions@bsigroup.com)

### Knowledge Centre

**Tel:** +44 20 8996 7004

**Email:** [knowledgecentre@bsigroup.com](mailto:knowledgecentre@bsigroup.com)

### Copyright & Licensing

**Tel:** +44 20 8996 7070

**Email:** [copyright@bsigroup.com](mailto:copyright@bsigroup.com)



...making excellence a habit.™