

BS EN ISO 5459:2011



BSI Standards Publication

**Geometrical product
specifications (GPS) —
Geometrical tolerancing —
Datums and datum systems
(ISO 5459:2011)**

bsi.

...making excellence a habit.™

National foreword

This British Standard is the UK implementation of EN ISO 5459:2011. It supersedes BS ISO 5459:1981 which is withdrawn.

The UK participation in its preparation was entrusted to Technical Committee TDW/4, Technical Product Realization.

A list of organizations represented on this committee can be obtained on request to its secretary.

This publication does not purport to include all the necessary provisions of a contract. Users are responsible for its correct application.

© BSI 2011

ISBN 978 0 580 53481 2

ICS 01.100.20; 17.040.10

Compliance with a British Standard cannot confer immunity from legal obligations.

This British Standard was published under the authority of the Standards Policy and Strategy Committee on 31 August 2011.

Amendments issued since publication

Date	Text affected
------	---------------

ICS 01.100.20; 17.040.10

English Version

Geometrical product specifications (GPS) - Geometrical tolerancing - Datums and datum systems (ISO 5459:2011)

Spécification géométrique des produits (GPS) -
Tolérancement géométrique - Références spécifiées et
systèmes de références spécifiées (ISO 5459:2011)

Geometrische Produktspezifikation (GPS) - Geometrische
Tolerierung - Bezüge und Bezugssysteme (ISO 5459:2011)

This European Standard was approved by CEN on 18 May 2011.

CEN members are bound to comply with the CEN/CENELEC Internal Regulations which stipulate the conditions for giving this European Standard the status of a national standard without any alteration. Up-to-date lists and bibliographical references concerning such national standards may be obtained on application to the CEN-CENELEC Management Centre or to any CEN member.

This European Standard exists in three official versions (English, French, German). A version in any other language made by translation under the responsibility of a CEN member into its own language and notified to the CEN-CENELEC Management Centre has the same status as the official versions.

CEN members are the national standards bodies of Austria, Belgium, Bulgaria, Croatia, Cyprus, Czech Republic, Denmark, Estonia, Finland, France, Germany, Greece, Hungary, Iceland, Ireland, Italy, Latvia, Lithuania, Luxembourg, Malta, Netherlands, Norway, Poland, Portugal, Romania, Slovakia, Slovenia, Spain, Sweden, Switzerland and United Kingdom.



EUROPEAN COMMITTEE FOR STANDARDIZATION
COMITÉ EUROPÉEN DE NORMALISATION
EUROPÄISCHES KOMITEE FÜR NORMUNG

Management Centre: Avenue Marnix 17, B-1000 Brussels

Foreword

This document (EN ISO 5459:2011) has been prepared by Technical Committee ISO/TC 213 "Dimensional and geometrical product specifications and verification" in collaboration with Technical Committee CEN/TC 290 "Dimensional and geometrical product specification and verification" the secretariat of which is held by AFNOR.

This European Standard shall be given the status of a national standard, either by publication of an identical text or by endorsement, at the latest by February 2012, and conflicting national standards shall be withdrawn at the latest by February 2012.

Attention is drawn to the possibility that some of the elements of this document may be the subject of patent rights. CEN [and/or CENELEC] shall not be held responsible for identifying any or all such patent rights.

According to the CEN/CENELEC Internal Regulations, the national standards organizations of the following countries are bound to implement this European Standard: Austria, Belgium, Bulgaria, Croatia, Cyprus, Czech Republic, Denmark, Estonia, Finland, France, Germany, Greece, Hungary, Iceland, Ireland, Italy, Latvia, Lithuania, Luxembourg, Malta, Netherlands, Norway, Poland, Portugal, Romania, Slovakia, Slovenia, Spain, Sweden, Switzerland and the United Kingdom.

Endorsement notice

The text of ISO 5459:2011 has been approved by CEN as a EN ISO 5459:2011 without any modification.

Contents

Page

Foreword	iv
Introduction.....	v
1 Scope	1
2 Normative references	1
3 Terms and definitions	2
4 Symbols.....	6
5 Role of datums.....	7
6 General concepts	9
6.1 General	9
6.2 Intrinsic characteristics of surfaces associated with datum features	10
6.2.1 General	10
6.2.2 A single datum established from a single feature	10
6.2.3 Common datum established from two or more single features simultaneously.....	10
6.2.4 Datum systems established in a defined sequence from two or more single features	12
6.3 Single datums, common datums and datum systems	12
6.3.1 General	12
6.3.2 Single datums	12
6.3.3 Common datums	14
6.3.4 Datum systems	14
7 Graphical language	17
7.1 General	17
7.2 Indication of datum features	17
7.2.1 Datum feature indicator	17
7.2.2 Datum feature identifier	18
7.2.3 Datum targets	18
7.3 Specification of datums and datum systems	21
7.4 Indication and meaning of rules	21
7.4.1 General	21
7.4.2 Rules	22
Annex A (normative) Association for datums.....	37
Annex B (informative) Invariance classes	47
Annex C (informative) Examples	49
Annex D (informative) Former practices.....	71
Annex E (informative) Examples of a datum system or a common datum established with contacting features	73
Annex F (normative) Relations and dimensions of graphical symbols	79
Annex G (informative) Relationship to the GPS matrix model	80
Bibliography.....	81

Foreword

ISO (the International Organization for Standardization) is a worldwide federation of national standards bodies (ISO member bodies). The work of preparing International Standards is normally carried out through ISO technical committees. Each member body interested in a subject for which a technical committee has been established has the right to be represented on that committee. International organizations, governmental and non-governmental, in liaison with ISO, also take part in the work. ISO collaborates closely with the International Electrotechnical Commission (IEC) on all matters of electrotechnical standardization.

International Standards are drafted in accordance with the rules given in the ISO/IEC Directives, Part 2.

The main task of technical committees is to prepare International Standards. Draft International Standards adopted by the technical committees are circulated to the member bodies for voting. Publication as an International Standard requires approval by at least 75 % of the member bodies casting a vote.

Attention is drawn to the possibility that some of the elements of this document may be the subject of patent rights. ISO shall not be held responsible for identifying any or all such patent rights.

ISO 5459 was prepared by Technical Committee ISO/TC 213, *Dimensional and geometrical product specification and verification*.

This second edition cancels and replaces the first edition (ISO 5459:1981), which has been technically revised.

Introduction

ISO 5459 is a geometrical product specification (GPS) standard and is to be regarded as a general GPS standard (see ISO/TR 14638). It influences the chain links 1 to 3 of the chain of standards on datums.

The ISO/GPS Masterplan given in ISO/TR 14638 gives an overview of the ISO/GPS system of which this standard is a part. The fundamental rules of ISO/GPS given in ISO 8015 apply to this standard and the default decision rules given in ISO 14253-1 apply to specifications made in accordance with this standard unless otherwise indicated.

For more detailed information of the relation of this International Standard to the GPS matrix model, see Annex G.

For the definitive presentation (proportions and dimensions) of symbols for geometrical tolerancing, see ISO 7083.

The previous version of ISO 5459 dealt only with planes, cylinders and spheres being used as datums. There is a need to consider all types of surfaces, which are increasingly used in industry. The definitions of classes of surfaces as given in Annex B are exhaustive and unambiguous.

This edition of ISO 5459 applies new concepts and terms that have not been used in previous ISO GPS standards. These concepts are described in detail in ISO/TR 14638, ISO 17450-1 and ISO 17450-2; therefore, it is recommended to refer to these standards when using ISO 5459.

This International Standard provides tools to express location or orientation constraints, or both, for a tolerance zone. It does not provide information about the relationship between datums or datum systems and functional requirements or applications.

Geometrical product specifications (GPS) — Geometrical tolerancing — Datums and datum systems

1 Scope

This International Standard specifies terminology, rules and methodology for the indication and understanding of datums and datum systems in technical product documentation. This International Standard also provides explanations to assist the user in understanding the concepts involved.

This International Standard defines the specification operator (see ISO 17450-2) used to establish a datum or datum system. The verification operator (see ISO 17450-2) can take different forms (physically or mathematically) and is not the subject of this International Standard.

NOTE The detailed rules for maximum and least material requirements for datums are given in ISO 2692.

2 Normative references

The following referenced documents are indispensable for the application of this document. For dated references, only the edition cited applies. For undated references, the latest edition of the referenced document (including any amendments) applies.

ISO 128-24:1999, *Technical drawings — General principles of presentation — Part 24: Lines on mechanical engineering drawings*

ISO 1101:2004, *Geometrical Product Specifications (GPS) — Geometrical tolerancing — Tolerances of form, orientation, location and run-out*

ISO 1101:2004/Amd 1:—¹⁾, *Geometrical Product Specifications (GPS) — Geometrical tolerancing — Tolerances of form, orientation, location and run-out — Amendment 1: Representation of specifications in the form of a 3D model*

ISO 2692:2006, *Geometrical product specifications (GPS) — Geometrical tolerancing — Maximum material requirement (MMR), least material requirement (LMR) and reciprocity requirement (RPR)*

ISO 3098-0, *Technical product documentation — Lettering — Part 0: General requirements*

ISO 3098-5, *Technical product documentation — Lettering — Part 5: CAD lettering of the Latin alphabet, numerals and marks*

ISO 14660-1:1999, *Geometrical Product Specifications (GPS) — Geometrical features — Part 1: General terms and definitions*

ISO 17450-1, *Geometrical product specifications (GPS) — General concepts — Part 1: Model for geometrical specification and verification*

ISO 17450-2, *Geometrical product specifications (GPS) — General concepts — Part 2: Basic tenets, specifications, operators and uncertainties*

ISO 81714-1, *Design of graphical symbols for use in the technical documentation of products — Part 1: Basic rules*

1) To be published.

3 Terms and definitions

For the purposes of this document, the terms and definitions given in ISO 1101, ISO 2692, ISO 14660-1, ISO 17450-1, ISO 17450-2 and the following apply.

3.1 situation feature
point, straight line, plane or helix from which the location and orientation of features, or both, can be defined

3.2 datum feature
real (non-ideal) integral feature used for establishing a datum

NOTE 1 A datum feature can be a complete surface, a portion of a complete surface, or a feature of size.

NOTE 2 An illustration showing the relations between datum feature, associated feature and datum is given in Figure 4.

3.3 associated feature
associated feature for establishing a datum

ideal feature which is fitted to the datum feature with a specific association criterion

NOTE 1 The type of the associated feature is by default the same as the type of the nominal integral feature used to establish the datum (for an exception see 7.4.2.5).

NOTE 2 The associated feature for establishing a datum simulates the contact between the real surface of the workpiece and other components.

NOTE 3 An illustration showing the relations between datum feature, associated feature and datum is given in Figure 4.

3.4 datum
one or more situation features of one or more features associated with one or more real integral features selected to define the location or orientation, or both, of a tolerance zone or an ideal feature representing for instance a virtual condition

NOTE 1 A datum is a theoretically exact reference; it is defined by a plane, a straight line or a point, or a combination thereof.

NOTE 2 The concept of datums is inherently reliant upon the invariance class concept (see Annex A and Annex B).

NOTE 3 Datums with maximum material condition (MMC) or least material condition (LMC) are not covered in this International Standard (see ISO 2692).

NOTE 4 When a datum is established, for example, on a complex surface, the datum consists of a plane, a straight line or a point, or a combination thereof. The modifier [SL], [PL] or [PT], or a combination thereof, can be attached to the datum letter to limit the situation feature(s) taken into account relative to the surface.

NOTE 5 An illustration showing the relation between datum feature, associated feature and datum is given in Figure 4.

3.5 primary datum
datum that is not influenced by constraints from other datums

3.6 secondary datum
datum, in a datum system, that is influenced by an orientation constraint from the primary datum in the datum system

3.7

tertiary datum

datum, in a datum system, that is influenced by constraints from the primary datum and the secondary datum in the datum system

3.8

single datum

datum established from one datum feature taken from a single surface or from one feature of size

NOTE The invariance class of a single surface can be complex, prismatic, helical, cylindrical, revolute, planar or spherical. A set of situation features defining the datum (see Table B.1) corresponds to each type of single surface.

3.9

common datum

datum established from two or more datum features considered simultaneously

NOTE To define a common datum, it is necessary to consider the collection surface created by the considered datum features. The invariance class of a collection surface can be complex, prismatic, helical, cylindrical, revolute, planar or spherical (see Table B.1).

3.10

datum system

set of two or more situation features established in a specific order from two or more datum features

NOTE To define a datum system, it is necessary to consider the collection surface created by the considered datum features. The invariance class of a collection surface can be complex, prismatic, helical, cylindrical, revolute, planar or spherical (see Table B.1).

3.11

datum target

portion of a datum feature which can nominally be a point, a line segment or an area

NOTE Where the datum target is a point, a line or an area, it is indicated as a datum target point, a datum target line or a datum target area, respectively.

3.12

moveable datum target

datum target with a controlled motion

3.13

collection surface

two or more surfaces considered simultaneously as a single surface

NOTE 1 Table B.1 is used to determine the invariance class of a datum or datum systems when using a collection of surfaces.

NOTE 2 Two intersecting planes may be considered together or separately. When the two intersecting planes are considered simultaneously as a single surface, that surface is a collection surface.

3.14

feature of size

geometrical shape defined by a linear or angular dimension which is a size

NOTE The features of size can be a cylinder, a sphere, two parallel opposite surfaces, a cone or a wedge.

[ISO 14660-1:1999, 2.2]

NOTE In this International Standard, features which are not features of size according to ISO 14660-1 are used to establish a datum as a feature of size, e.g. a truncated sphere (see the example in C.1.4).

3.15

objective function

objective function for association

formula that describes the quality of association

NOTE 1 In this International Standard, the term “objective function” refers to “objective function for association”.

NOTE 2 The objective functions are usually named and mathematically described: maximum inscribed, minimum zone, etc.

3.16

association

operation used to fit ideal feature(s) to non-ideal feature(s) according to an association criterion

[ISO 17450-1:—, 3.2]

3.17

constraint

limitation on the associated feature

EXAMPLE Orientation constraint, location constraint, material constraint or intrinsic characteristic constraint.

3.17.1

orientation constraint

limitation to one or more rotational degrees of freedom

3.17.2

location constraint

limitation to one or more translational degrees of freedom

3.17.3

material constraint

additional condition to the location of the associated feature, relative to the material of the feature, while optimizing an objective function

NOTE For example, an association constraint can be that all distances between the associated feature and the datum feature are positive or equal to zero, i.e. the associated feature is outside the material.

3.17.4

intrinsic characteristic constraint

additional requirement applied to the intrinsic characteristic of an associated feature whether it is considered fixed or variable

3.18

association criterion

objective function with or without constraints, defined for an association

NOTE 1 Several constraints may be defined for an association.

NOTE 2 Association results (associated features) may differ, depending upon the choice of association criterion.

NOTE 3 Default association criteria are defined in Annex A.

3.19

integral feature

surface or line on a surface

NOTE An integral feature is intrinsically defined.

[ISO 14660-1:1999, 2.1.1]

3.20 contacting feature

ideal feature of any type which is different from the nominal feature under consideration and is associated with the corresponding datum feature

See Figure 1.

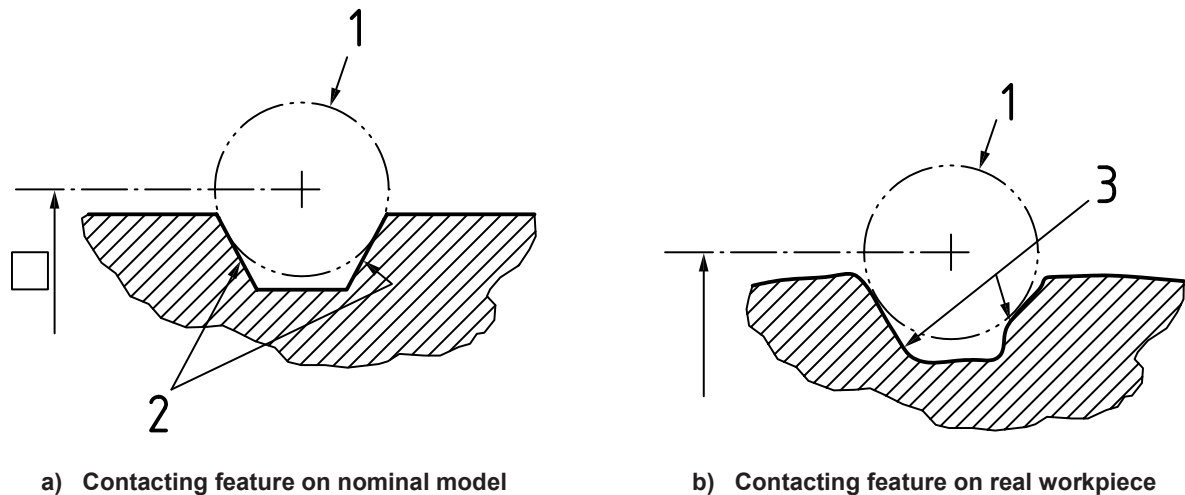

Key

- 1 contacting feature: ideal sphere in contact with the datum feature or the feature under consideration
- 2 features under consideration: nominal trapezoidal slot (collection of two non-parallel surfaces)
- 3 datum feature: real feature corresponding to the trapezoidal slot (collection of two non-parallel surfaces)

Figure 1 — Example of a contacting feature

3.21 invariance class

group of ideal features for which the nominal surface is invariant for the same degrees of freedom

NOTE There are seven invariance classes (see Annex B).

3.22 theoretically exact dimension

TED

dimension indicated on technical product documentation, which is not affected by an individual or general tolerance

NOTE 1 For the purpose of this International Standard, the term “theoretically exact dimension” has been abbreviated TED.

NOTE 2 A theoretically exact dimension is a dimension used in an operation (e.g. association, partition, collection, ...).

NOTE 3 A theoretically exact dimension can be a linear dimension or an angular dimension.

NOTE 4 A TED can define

- the extension or the relative location of a portion of one feature,
- the length of the projection of a feature,
- the theoretically exact orientation or location of one feature relative to one or more other features, or
- the nominal shape of a feature.

NOTE 5 A TED is indicated by a value in a rectangular frame.

[ISO 1101:2004/Amd 1:—, 3.7]

4 Symbols

Table 1 gives symbols to identify the datum feature or datum target used to establish a datum.

Table 2 gives the list of modifier symbols, which can be associated the datum letter.

Table 1 — Datum features and datum target symbols





Description	Symbol	Subclause
Datum feature indicator		7.2.1
Datum feature identifier	Capital letter (A, B, C, AA, etc.)	7.2.2
Single datum target frame		7.2.3.2
Moveable datum target frame		7.2.3.2
Datum target point		7.2.3.3
Closed datum target line		7.2.3.3
Non-closed datum target line		7.2.3.3
Datum target area		7.2.3.3

Table 2 — Modifier symbols

Symbol	Description	Subclause
[PD]	Pitch diameter	7.4.2.1
[MD]	Major diameter	7.4.2.1
[LD]	Minor diameter	7.4.2.1
[ACS]	Any cross section	7.4.2.4
[ALS]	Any longitudinal section	7.4.2.4
[CF]	Contacting feature	7.4.2.5
[DV]	Variable distance (for common datum)	7.4.2.7
[PT]	(situation feature of type) Point	7.4.2.8
[SL]	(situation feature of type) Straight line	7.4.2.8
[PL]	(situation feature of type) Plane	7.4.2.8
><	For orientation constraint only	7.4.2.8
Ⓟ	Projected (for secondary or tertiary datum)	7.4.2.10
Ⓛ	Least material requirement	See ISO 2692
Ⓜ	Maximum material requirement	See ISO 2692

5 Role of datums

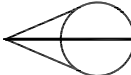
Datums form part of a geometrical specification (see ISO 1101).

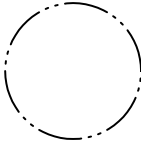
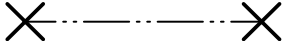
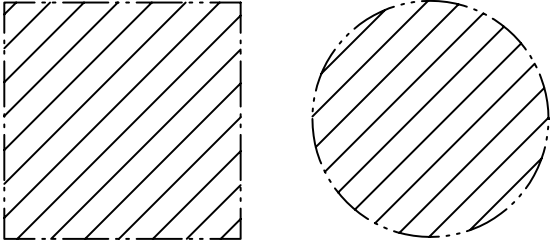
Datums are established from real surfaces identified on a workpiece.

Datums allow tolerance zones to be located or orientated (see Examples 1 and 2) and virtual conditions to be defined (for example maximum material virtual condition Ⓜ according to ISO 2692). The datums can be seen as a means to lock degrees of freedom of a tolerance zone. The number of degrees of freedom of the tolerance zone which are locked depends on the nominal shape of the features utilized to establish the datum or datum system; whether the datum is primary, secondary or tertiary; and on the toleranced characteristic indicated in the geometrical tolerance frame.

By default, a datum locks all the degrees of freedom of the tolerance zone that it can lock given its shape and which

- are required by the geometrical characteristic indicated in the tolerance frame, and
- have not already been locked by the preceding datum(s) in the datum system.

When a datum locks only orientation degrees of freedom, this shall be indicated by the modifier ><.

EXAMPLE 1 The tolerance zone, which is the space between two parallel planes 0,1 mm apart, is constrained in orientation by a 75° theoretically exact angle from the datum. Here, the datum is the situation feature of a cylinder (axis of associated cylinder). See Figure 2.

Dimensions in millimetres

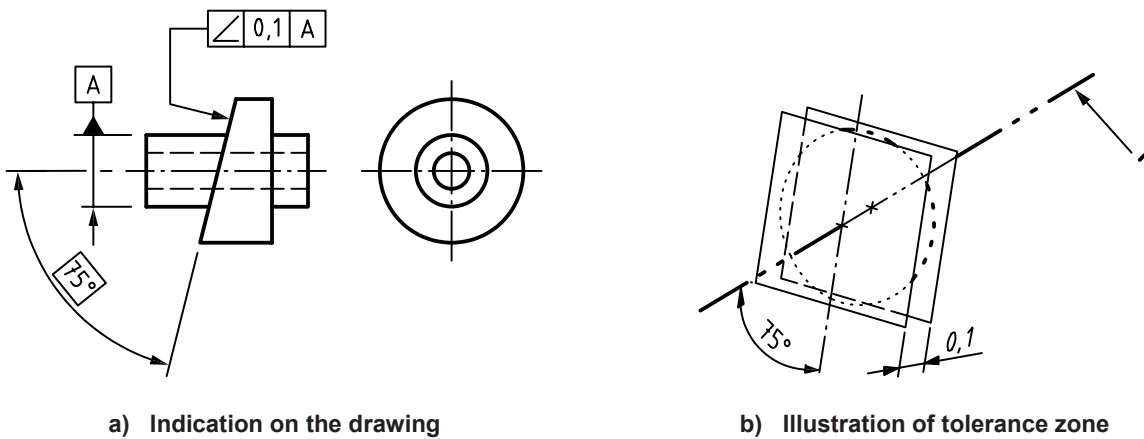

Key

- 1 datum A constituted by the axis of the associated cylinder

Figure 2 — Example of tolerance zone constrained in orientation from a datum

EXAMPLE 2 The tolerance zone, which is the space between two parallel planes 0,2 mm apart, is constrained in orientation by a 70° angle from a datum, and in location by the distance 20 mm from the gauge plane positioned perpendicular to the axis of 40° cone where its local diameter is 30 mm. Here, the datum consists of the set of situation features of the cone with a fixed angle of 40° , i.e. the cone axis and the point of intersection between the gauge plane and that axis. See Figure 3.

Dimensions in millimetres

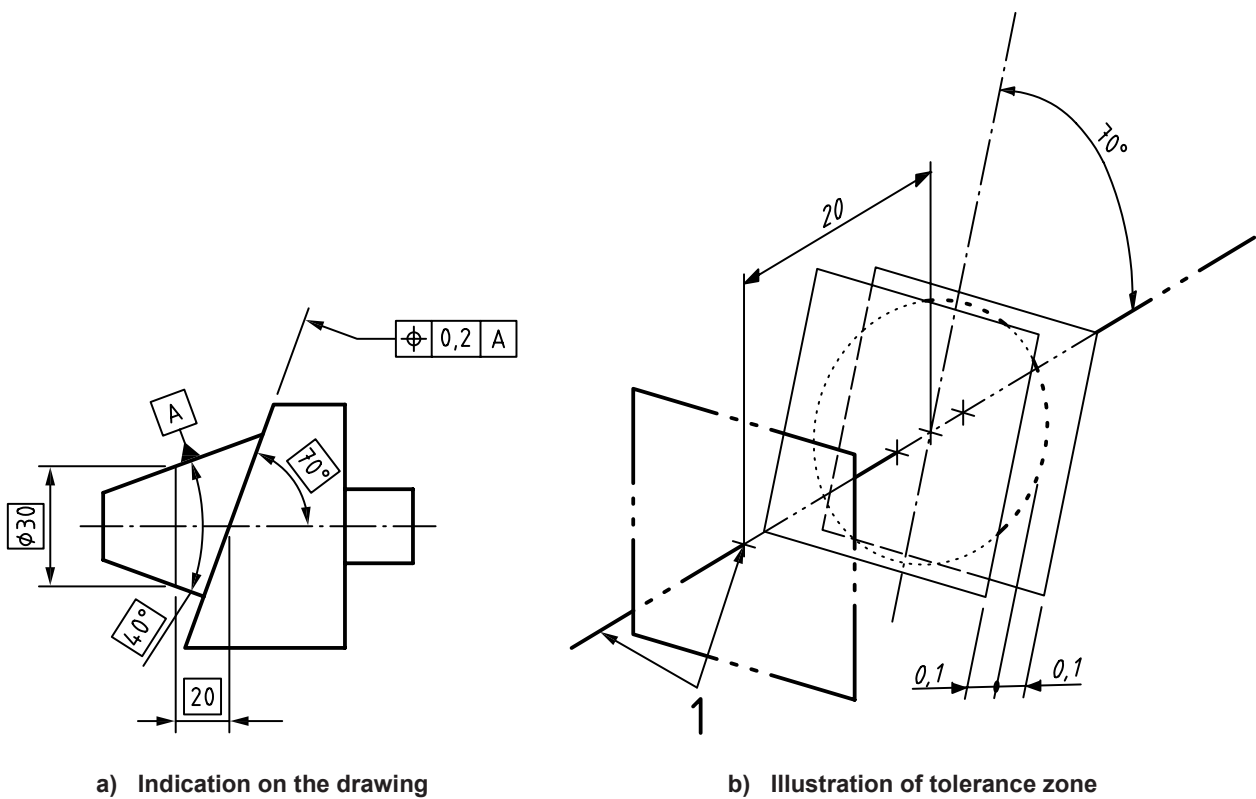

Key

- 1 datum A constituted by the axis of the associated cone, the point of intersection of the gauging plane and this axis

Figure 3 — Example of a tolerance zone constrained in location from a datum

6 General concepts

6.1 General

Datums and datum systems are theoretically exact geometric features used together with implicit or explicit TEDs to locate or orientate

- a) tolerance zones for toleranced features, or
- b) virtual conditions, e.g. in the case of maximum material requirement (see ISO 2692).

A datum consists of a set of situation features for an ideal feature (feature of perfect form). This ideal feature is an associated feature which is established from the identified datum features of a workpiece. Datum features may be complete features, or identified portions thereof (see Clause 7).

A datum system consists of more than one datum.

The geometrical type of these associated features belongs to one of the following invariance classes:

- spherical (i.e. a sphere);
- planar (i.e. a plane);
- cylindrical (i.e. a cylinder);
- helical (e.g. a threaded surface)²⁾;
- revolute (e.g. a cone or a torus);
- prismatic (e.g. a prism);
- complex (e.g. a free-form surface).

Each single or collection feature belongs to one invariance class (for an explanation of invariance classes, invariance degree, and degree of freedom, see Annex B).

Associated features are established from the real or extracted single features used for the datum. The associated feature can be defined by an operation of association including constraints coming from the feature itself or from one or more other features. The situation features that make up the datum are defined from these associated features. The default association methods are given in Annex A.

One or more single features can be used to establish a datum. If only one single feature is used, it establishes a single datum. If more than one single feature is used, they can either be considered simultaneously to establish a common datum or in a predefined order to establish a datum system (see 6.3).

The datum feature(s) to be used for establishing each datum shall be designated and identified.

The single datums (see 6.3.2), common datums (see 6.3.3) or datum systems (see 6.3.4), as applicable, shall be specified for each geometrical specification.

When applicable, any additional constraints shall be defined for the association.

2) Helical surfaces as such are not considered in this International Standard. They are regarded as cylindrical surfaces because, in most functional cases where helical surfaces (threads, helical slope, endless screw, etc.) are involved, the combined rotation and translation of the helix is not needed for datum purposes. In these cases, the pitch cylinder surface is used to establish the datum. The major or minor cylindrical surface can also be considered and specified.

NOTE Datums and datum systems are geometrical features, not coordinate systems. Coordinate systems can be built on datums, but this International Standard does not provide the means to express them.

EXAMPLE In Figure 4, the datum is indicated as a single datum derived from a nominal feature, a cylinder, used to orientate or locate a tolerance zone. In order to derive the datum, the following sequence of operations is performed:

- a partition to define the real integral surface corresponding to the nominal feature [see Figure 4 b)];
- an extraction to provide the extracted integral feature [see Figure 4 c)];
- a filtration (see Annex A);
- an association (see Annex A for association method) to define the associated feature. (In this case, its type is the same as the nominal feature.) The associated feature [see Figure 4 d)] is established from the non-ideal surface (in the specification process) or from the extracted feature (in the verification process).

The datum is defined as the situation feature (the axis) of the associated cylinder [see Figure 4 e)].

6.2 Intrinsic characteristics of surfaces associated with datum features

6.2.1 General

The default intrinsic characteristic constraint (variable or fixed) shall be as defined in 6.2.2, 6.2.3 or 6.2.4.

For datums with virtual conditions, see ISO 2692:2006.

6.2.2 A single datum established from a single feature

The intrinsic characteristic constraints for a single feature of size are, by default, variable for linear sizes but theoretically exact for the angular dimensions or for dimensions which are not sizes (see Table 3 and 7.4.2.2).

EXAMPLE For a cone, by default, the angle is considered a theoretically exact angle. For a torus, by default, the cross-section diameter is considered a variable (size of torus), but the median ring diameter of the axis should be considered theoretically exact.

Table 3 — Default status of intrinsic characteristics of features of size

Feature of size	Invariance class	Intrinsic characteristic	Default status
Cylinder	cylindrical	diameter	Variable See example in C.1.2.
Sphere	spherical	diameter	Variable See example in C.1.4.
Two parallel opposite planes	planar	distance between the two planes	Variable See example in C.1.10.
Cone	revolute	angle	Theoretically exact See example in C.1.3.
Wedge	prismatic	angle	Theoretically exact See example in C.1.9.

6.2.3 Common datum established from two or more single features simultaneously

The intrinsic characteristics of each associated feature establishing the common datum shall be considered as in 6.2.2.

Intrinsic characteristics introduced by the collection of features (defining the relation between the associated features) shall by default be considered theoretically exact for both linear and angular dimensions.

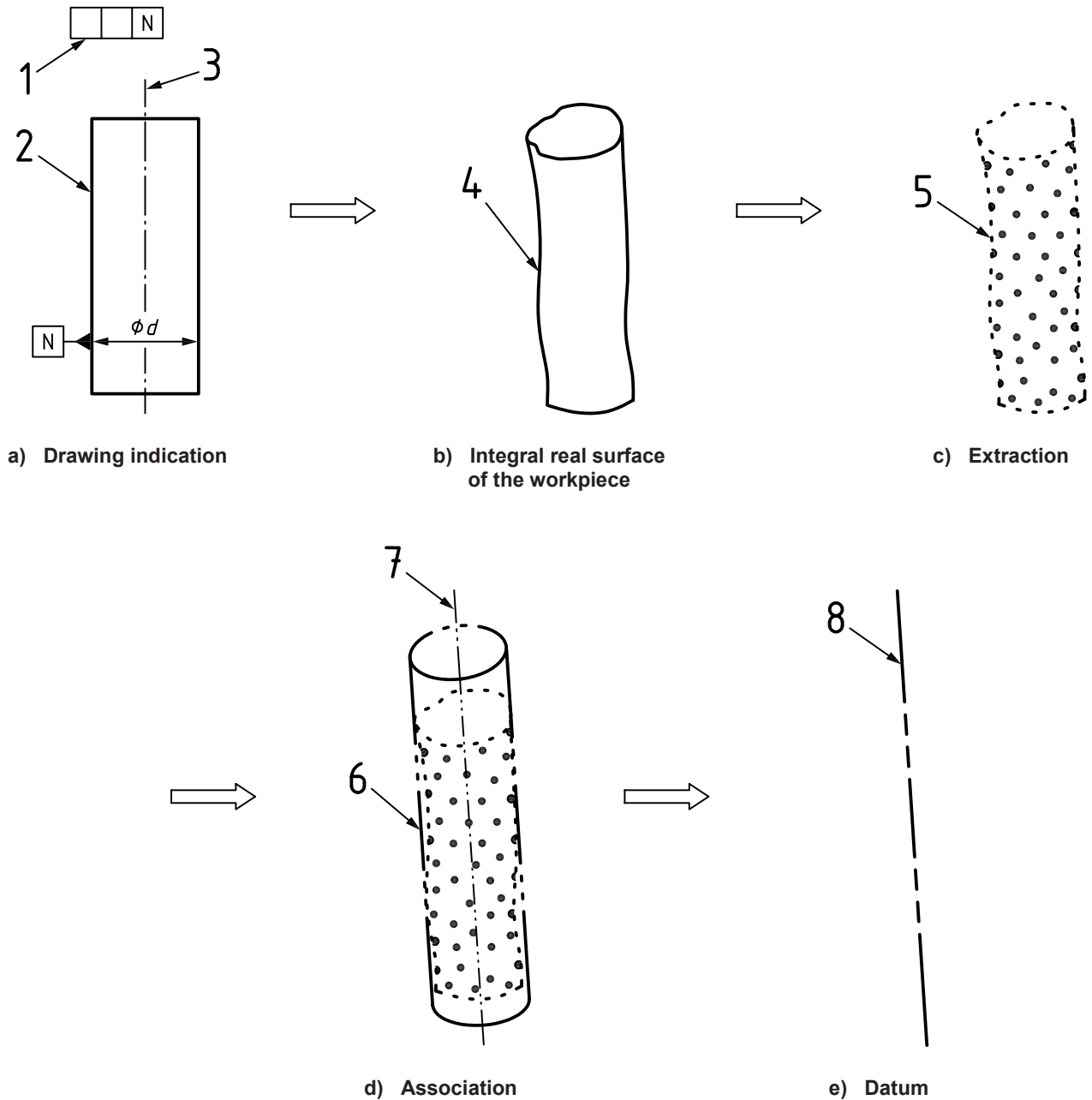

Key

- 1 tolerance frame to be linked to a toleranced feature
- 2 nominal integral feature (which is a feature of size)
- 3 nominal derived feature
- 4 real integral feature (datum feature in this case)
- 5 extracted integral feature (optional)
- 6 associated integral feature
- 7 derived feature of associated integral feature
- 8 single datum (situation feature of the associated surface)

In the example shown in Figure 4 e), the derived feature (key 7) and the situation feature (key 8) are the same as each other; however, this is not always the case.

Figure 4 — Illustration of features used for establishing a single datum from a cylinder

EXAMPLE A common datum is established from two parallel non-coaxial cylinders (invariance class: prismatic). Each individual cylinder has an intrinsic characteristic, its diameter. The collection of features also has intrinsic characteristics: an angle, defined by the fact that two axes restrict the twist of the datum, and the distance between the two axes (see C.2.4). The two diameters of the cylinders are considered by default variable and the twist angle and the distance between the two are considered theoretically exact.

NOTE See also 6.3.3, 7.4.2.7 and 7.4.2.9 for the special case where the linear dimensions between features included in the collection can be considered variable by using the modifier [DV].

6.2.4 Datum systems established in a defined sequence from two or more single features

The intrinsic characteristics of each associated feature establishing the datum system shall be considered as in 6.2.2.

The intrinsic characteristics introduced by the collection of features (defining the relation between the associated features) shall be considered variable for linear dimensions but theoretically exact for the angular dimensions.

6.3 Single datums, common datums and datum systems

6.3.1 General



When a single surface or a collection surface is identified as a datum feature, the invariance degrees for which the surface is invariant shall be identified and compared with Table B.1 in order to determine the set of situation features (point, straight line, plane or helix, or a combination thereof) that constitutes the datum.

6.3.2 Single datums

A single datum consists of one or more situation features based on one single feature or a portion thereof.

NOTE A single datum taken from a cone has two situation features: its axis and a point on that axis.

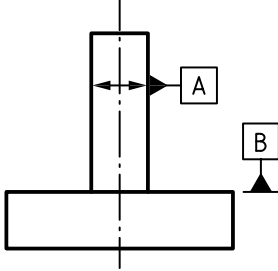
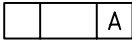
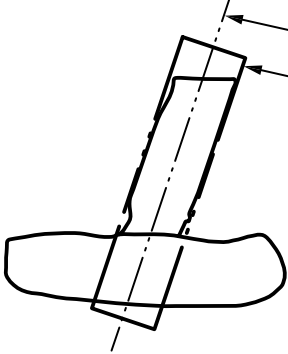
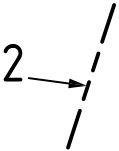
EXAMPLE Single datum taken from a cylinder or a plane.

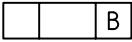
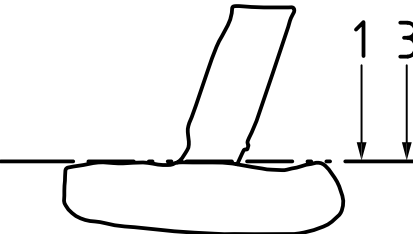
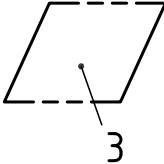
Indication of datum feature	Indication of datum in tolerance frame	Illustration of the meaning	Invariance class and situation feature (see Annex B)	Datum
			<p>Cylindrical</p> <p>Axis of associated cylinder</p>	
			<p>Planar</p> <p>Associated plane</p>	

Key

- 1 associated feature (without orientation constraint)
- 2 straight line which is the situation feature of the associated cylinder (its axis)
- 3 plane which is the situation feature of the associated plane (the associated plane itself)

NOTE Association for single datums is described in Annex A.

If a single datum is used as the only datum in a tolerance frame, or if it is the primary datum in a datum system, the associated feature to the real integral feature (or to the portions of it) used for establishing the datum is obtained without external orientation constraints or location constraints.

For the constraints that are applied, when a single datum is used as a “secondary datum” or a “tertiary datum”, see 6.3.4.

Additional examples of single datums are given in C.1.

For a feature of size made up of two opposite parallel planes, the collection surface associated with the surfaces (or to the portions of the surfaces) used for establishing the datum is obtained with an internal orientation constraint; the associated surfaces (constituting the collection surface) are individually defined with an internal parallelism constraint and a variable intrinsic characteristic constraint (see C.1.10).

A secondary datum shall not be specified when it does not constrain more degrees of freedom of the tolerance zone than the primary datum.

A tertiary datum shall not be specified when it does not constrain more degrees of freedom of the tolerance zone than the primary and the secondary datums.

6.3.3 Common datums

A common datum consists of one or more situation features established by taking into account the collection surface.

If the common datum is used as the only datum in a tolerance frame, or if it is the primary datum in a datum system, the collection of associated features used for establishing the datums, is established without external orientation constraints or location constraints; therefore, the surfaces (constituting the collection surface) are associated together, simultaneously. For the constraints that are applied when a common datum is used as a “secondary datum” or a “tertiary datum”, see 6.3.4.

A secondary datum shall not be specified when it does not constrain more degrees of freedom of the tolerance zone than the primary datum.

A tertiary datum shall not be specified when it does not constrain more degrees of freedom of the tolerance zone than the primary and the secondary datums.

Examples of common datums are given in 6.3.4 (Examples 1 and 2 illustrate the difference between a datum system and a common datum) and C.2.

The complementary indication [DV] (meaning “distance variable”) following the letters indicating a common datum in a tolerance frame means that the linear dimensions between the situation features are variable. See also 7.4.2.9 and E.4.

6.3.4 Datum systems

A datum system is constituted by an ordered sequence of two or three single or common datums. A datum system consists of two or three situation features resulting from the collection of the considered surfaces.

The associated features used to establish the datum system are derived sequentially, in the order defined by the geometrical specification. The relative orientation of the associated surfaces is theoretically exact but their relative location is variable.

This order defines the orientation constraints for the association operation: the primary datum imposes orientation constraints on the secondary datum and tertiary datum; the secondary datum imposes orientation constraints on the tertiary datum.

A secondary datum shall be specified when it is necessary to constrain more degrees of freedom of the tolerance zone than are constrained by the primary datum.

A tertiary datum shall be specified when it is necessary to constrain more degrees of freedom of the tolerance zone than are constrained by the primary and the secondary datums.

A secondary or tertiary datum shall not be specified when it does not constrain more degrees of freedom of the tolerance zone than are constrained by the primary datum and in the case of a tertiary datum also by the secondary datums.

Additional examples of datum systems are given in C.3.

EXAMPLE 1 Common datum or datum system taken from a cylinder and a plane.

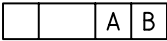
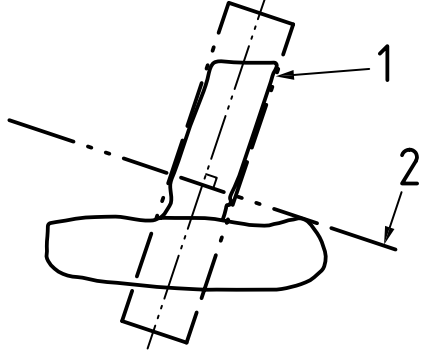
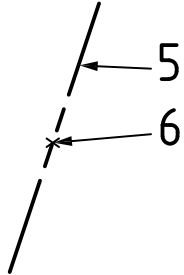
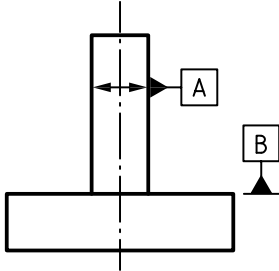
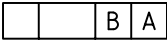
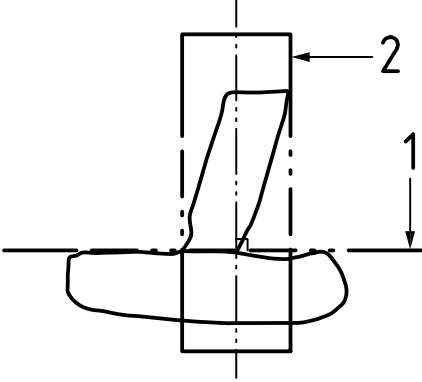
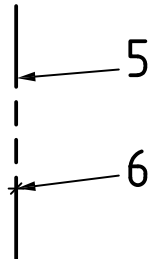
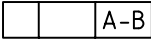
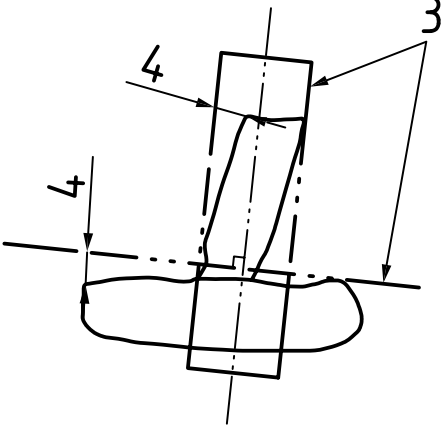
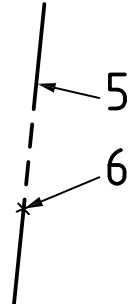
Indication of datum feature	Indication of datum in tolerance frame	Meaning on workpiece	Resulting common datum or datum system
			
			
			

Key

- 1 first associated feature without orientation constraint
- 2 second associated feature with orientation constraint from the first associated feature
- 3 simultaneously associated features with orientation constraint and location constraint
- 4 maximum distance balanced between the associated features and datum features
- 5 straight line which is the situation feature of the associated cylinder (its axis)
- 6 point of intersection between the straight line and the plane

NOTE 1 The orientation and location of datums are different depending on the datum indications in the tolerance frame.

NOTE 2 The association for datum systems is described in A.2.4.

EXAMPLE 2 Common datum or datum system taken from two cylinders.

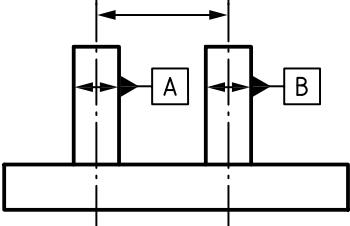
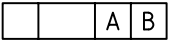
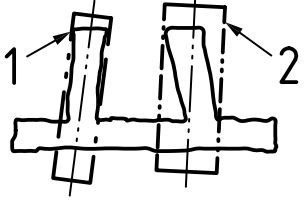
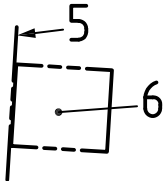
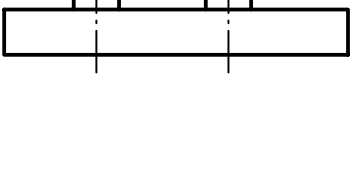
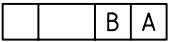
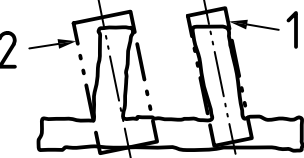
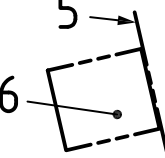
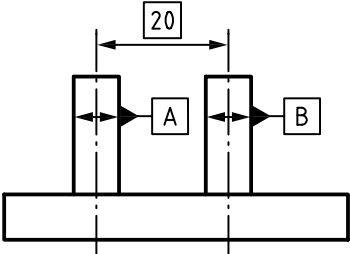
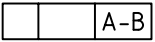
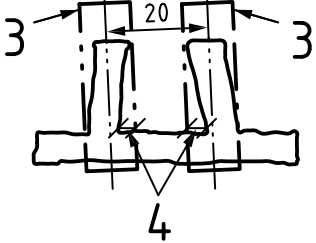
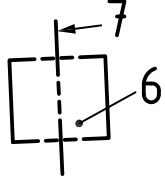
Indication of datum feature	Indication of datums in tolerance frame	Meaning on workpiece	Resulting datum or datum system
			
			
			



Key

- 1 first associated cylinder without constraint
- 2 second associated cylinder with parallelism constraint from the first associated feature
- 3 simultaneously associated cylinders with parallelism constraint and location constraint
- 4 maximum distance balanced between the associated cylinders and datum features
- 5 straight line which is the axis of the first associated cylinder
- 6 plane including the axes of the two associated cylinders
- 7 median straight line of the axes of the two simultaneously associated cylinders

NOTE 1 The orientation and location of datums are different depending on the datum indication in the tolerance frame. Not all possibilities for establishing the datums are covered.

NOTE 2 For the association method, see Annex A.

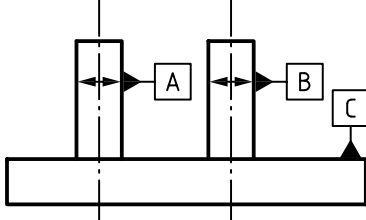
EXAMPLE 3 Datum system taken from two cylinders and a plane.

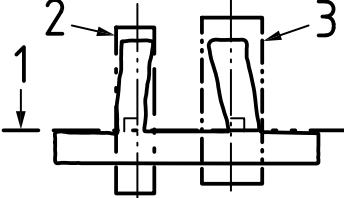
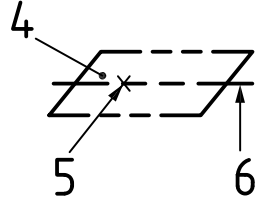
Indication of datum feature	Indication of datums in tolerance frame	Meaning on workpiece	Resulting datum or datum system
			
<p>Key</p> <p>1 first associated feature without a constraint</p> <p>2 second associated feature with a perpendicularity constraint from the first associated feature</p> <p>3 third associated feature with a perpendicularity constraint from the first associated feature (and parallelism constraint from the second one)</p> <p>4 plane which is the first associated feature</p> <p>5 point of intersection between the plane and the axis of the second associated feature</p> <p>6 straight line which is the intersection between the associated plane and the plane containing the two axes</p> <p>NOTE For the association method, see Annex A.</p>			

7 Graphical language

7.1 General

The expression of geometrical tolerances with datums in geometrical specifications on drawings includes the following steps.

- Indicate the integral surfaces of the workpiece which are to be used as datum features. When a complete integral surface is not required for a datum feature, the considered portion(s) [area(s), line(s) or point(s)] and the corresponding dimensions and locations shall be indicated.
- Indicate individual single datums, individual common datums or datum systems.
- Indicate the orientation constraints and/or location constraints for the tolerance zones in relation to the indicated datums.
- Indicate the association criteria. This International Standard defines the default association criteria in Annex A. If a different association criterion is required, it shall be indicated.
- Indicate, where necessary, the use of the maximum or least material requirement (see ISO 2692) or projected datum.

7.2 Indication of datum features

7.2.1 Datum feature indicator

Single features to be used for establishing datum features shall be indicated by a box linked to a filled or open datum triangle by a leader line (see Figure 5).

NOTE There is no difference in meaning between a filled and an open datum triangle.



Figure 5 — Datum feature indicator

7.2.2 Datum feature identifier

Single features used for establishing datum features shall be identified by a datum feature identifier placed in the datum feature indicator. A datum feature identifier consists of one or more capital letters which are not to be separated by hyphens.

The letters I, O, Q and X (which can be misinterpreted) should not be used.

If a drawing has exhausted the alphabet, or if it is useful for the comprehension of the drawing, it is recommended that an unambiguous coding system be defined; for example by repeating the same letter, e.g. two times, three times, etc. (e.g. BB, CCC, etc.). In order to facilitate the reading of this International Standard, only one letter is used in the rest of the document.

7.2.3 Datum targets

7.2.3.1 General

When it is not desirable to use a complete integral feature to establish a datum feature, it is possible to indicate portions of the single feature (areas, lines or points) and their dimensions and locations. These portions are called datum targets. They usually simulate the interface between the considered single feature of the workpiece and one or more contacting ideal features (assembly interface features or fixture features).

A datum target is indicated by a datum target indicator. This indicator is constructed from a datum target frame, a datum target symbol and a leader line linking the two symbols (directly, or through a reference line).

It may be necessary to indicate the same datum target on several appropriate views in order to have an unambiguous definition (see Figures 26, 27, 28 and 29).

7.2.3.2 Datum target frame

The datum target frame is a circle, divided into two compartments by a horizontal line (see Figure 6). The lower compartment is reserved for the datum feature identifier followed by a digit (from 1 to n), corresponding to the datum target number.

The upper compartment is reserved for additional information, such as dimensions of the target area.



Figure 6 — Single datum target frame

The moveable modifier is constituted by two tangential lines from the circle of the datum target frame to the median segment (see Figure 7). The direction of the median segment of the moveable modifier is important. It specifies the movement direction where the distance between the moveable datum target and other datums or datum targets is not specified.

The moveable modifier is used to indicate the direction of movement of a physical feature or component simulating the datum or the datum system.

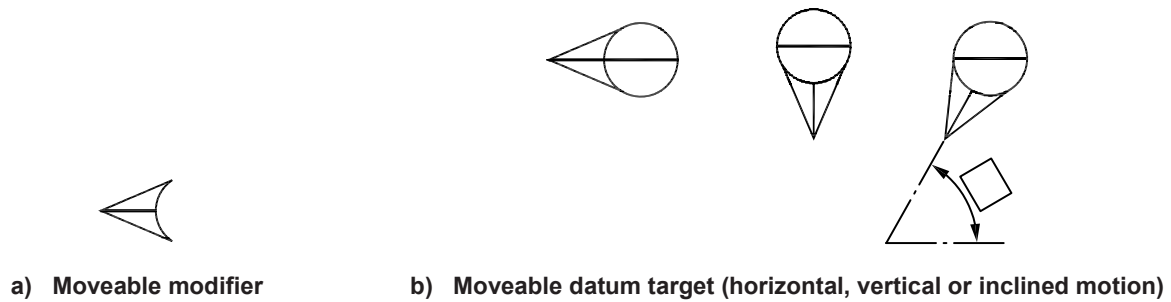

Figure 7 — Moveable modifier and examples of datum target frame with the moveable modifier

7.2.3.3 Datum target symbol

The datum target symbol indicates the type of datum target: point, line, or area, identifying a datum target point, a datum target line or a datum target area, respectively:

- a cross (see Figure 8);



Figure 8 — Datum target point

- a long-dashed double-dotted narrow line (type 05.1 of ISO 128-24:1999), which, when this line is not closed, is terminated by two crosses (see Figures 9 and 10). This line may be straight, circular or a line of any shape;

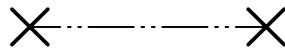

Figure 9 — Non-closed datum target line

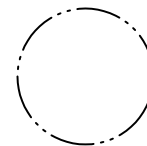

Figure 10 — Closed datum target line

- a hatched area surrounded by a long-dashed double-dotted narrow line (type 05.1 of ISO 128-24:1999) (see Figure 11).

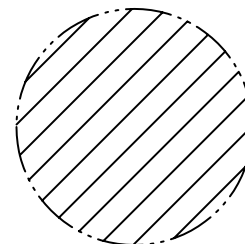
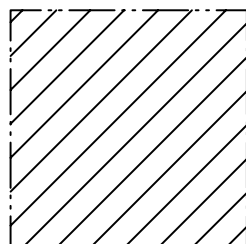

Figure 11 — Datum target area

7.2.3.4 Leader line

The datum target frame is connected directly, or through a reference line, to the datum target symbol by a leader line terminated with or without an arrow or a dot (see Figures 12, 13 and 14).

When the datum target point or the datum target line is not hidden, the leader line shall be continuous and shall be terminated with or without an arrow (see Figures 12 and 13).

When the datum target area is shown as an area in the relevant view and is not hidden, the leader line shall be continuous and shall be terminated with a dot [see Figure 15 b)].

When the considered surface is hidden, the leader line shall be dashed and terminated by an open circle for a datum target area [see Figure 15 a)] or without terminator for a datum target point or a datum target line.

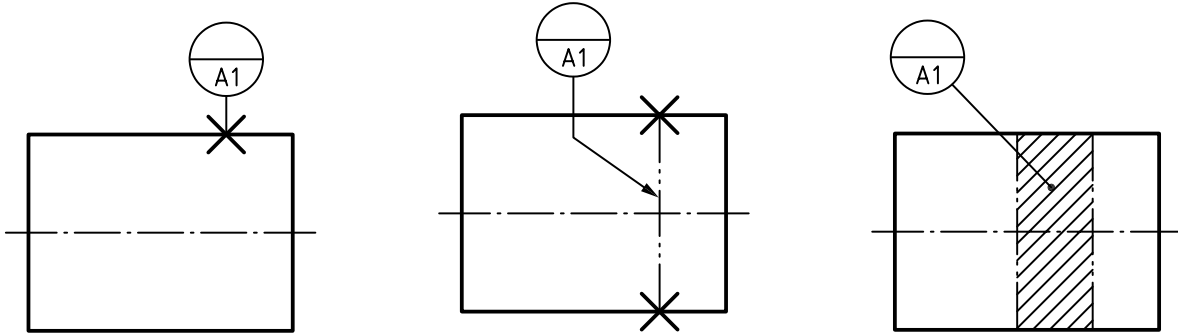

Figure 12 — Indicator for single datum target point

Figure 13 — Indicator for single datum target line

Figure 14 — Indicator for single datum target surface

The orientation of the leader line connecting the frame with the datum target symbol is unimportant.

A datum target should be indicated on a view where it is not hidden if possible (see Figure 15).

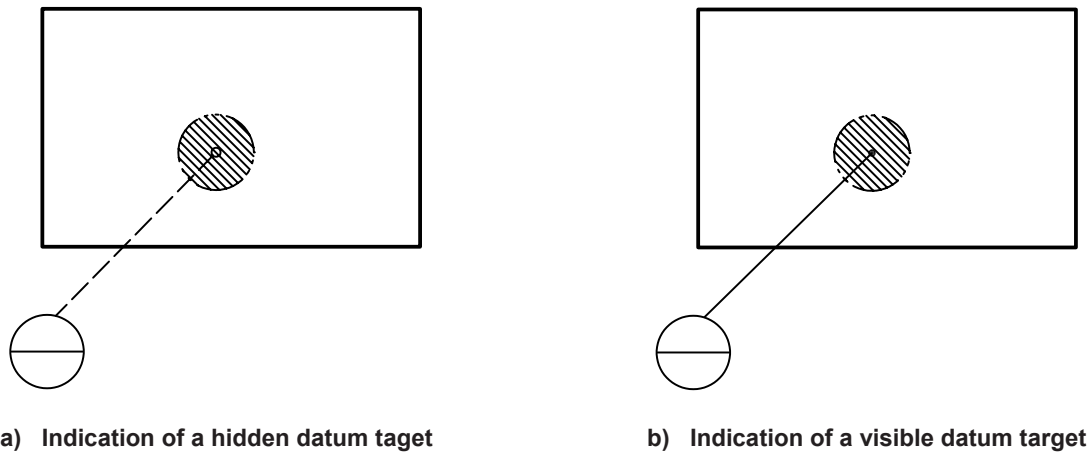

a) Indication of a hidden datum target

b) Indication of a visible datum target

Figure 15 — Example of indication of datum target

The moveable datum target modifier is used to define the direction in which the location of the datum target is not fixed.

The direction of the motion is indicated by the direction given by the moveable modifier and not by the leader line (see Figure 16).

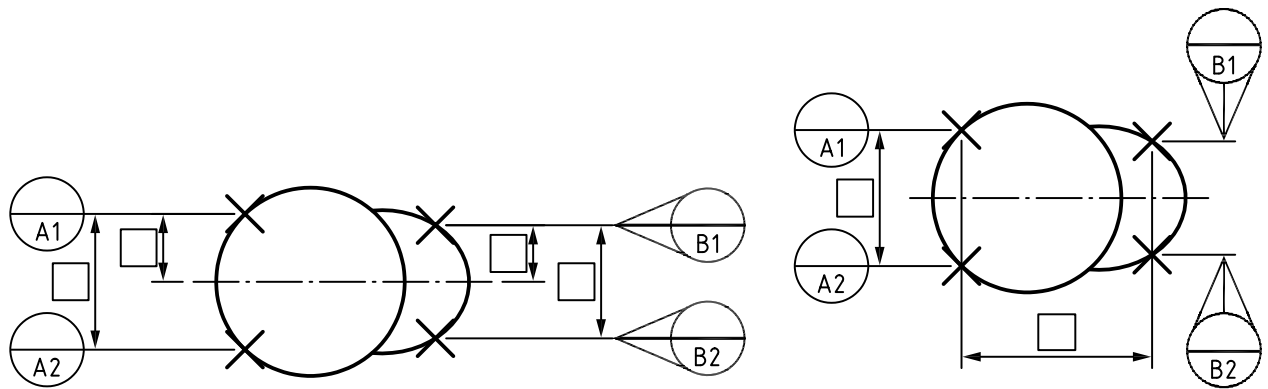

NOTE The motion of the moveable datum target, which is given by the direction of the moveable modifier, is perpendicular to a line going through the datum targets A1 and A2.

NOTE The motion of moveable datum target which is given by the direction of the modifier moveable is parallel to a line going through the datum targets A1 and A2.

a)

b)

Figure 16 — Example of moveable datum targets

7.3 Specification of datums and datum systems

The datum (or datum system) is specified in the third (and if necessary fourth and fifth) compartment of the tolerance frame (see Figure 17) as described in ISO 1101:2004, 6.1. See also rule 6 in 7.4.2.6.

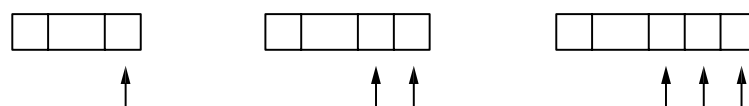

Figure 17 — Location of datum letter symbol(s) in the tolerance frame

7.4 Indication and meaning of rules

7.4.1 General

7.4.1.1 Humans interact with technical product documentation in two ways:

- designers encode the datum requirements into graphical language;
- other users decode the datum requirements from the graphical language.

The necessary rules are given in 7.4.2.

7.4.1.2 To encode the location constraints or orientation constraints, or both, for the tolerance zone from features on the workpiece, the following steps shall be performed.

- Indicate and identify all datum features used to establish the datum features with datum indicators (see rule 1) and, if necessary, define datum target(s) (see rules 3 and 4).
- Consider how the datums are established from the datum features by defining the manner of association, relevant constraints and types of features (see rules 2, 5, 6, 7, 8, 9 and 10).

7.4.1.3 If more than one associated feature is used to establish a datum or datum system, the associations shall be realized sequentially or simultaneously (see rules 6 and 7).

7.4.1.4 For the datum or each datum comprising the datum system, see the applicable rule as indicated below.

- If the type of associated feature is not the same as the datum feature (contacting feature), see rule 5.
- If the size of a feature of size is considered fixed or variable, see rule 2.
- If the constraint given by a datum needs to be reduced, see rules 8 and 9.
- If a geometrical modifier (\textcircled{M} , \textcircled{L} or \textcircled{P}) is required for a datum, see rule 10.

7.4.1.5 To decode the meaning of a datum or datum system, the following steps shall be performed.

- Read the tolerance frame to determine whether datums are used. If the tolerance frame contains more than two compartments, then at least one datum is used (see rule 6).
- Read all datum letter symbols corresponding to single datums or common datum components (see rule 7).
- Identify the datum feature corresponding to each datum letter symbol (see rule 1).
- Determine the datum feature is the complete integral feature (see rule 3). If not, it is necessary to read the datum target(s) and its (their) definition(s) (consider TEDs: see rule 4).
- Consider how the associations shall be processed to establish the datum (see rules 2, 5, 6, 7, 8, 9 and 10).

7.4.2 Rules

7.4.2.1 Rule 1 — Datum features (established from a single feature)

Where the single feature used for establishing a datum is a feature of size, the surface shall be designated by a datum feature indicator placed:

- *as an extension of a dimension line [see Figure 18 a)];*
- *on a tolerance frame pointing to an extension of a dimension line for the surface [see Figure 18 b)];*
- *on the reference line of a dimension [see Figure 18 c)];*
- *on a tolerance frame linked to a reference line with a dimension and pointing to the surface [see Figure 18 d)].*

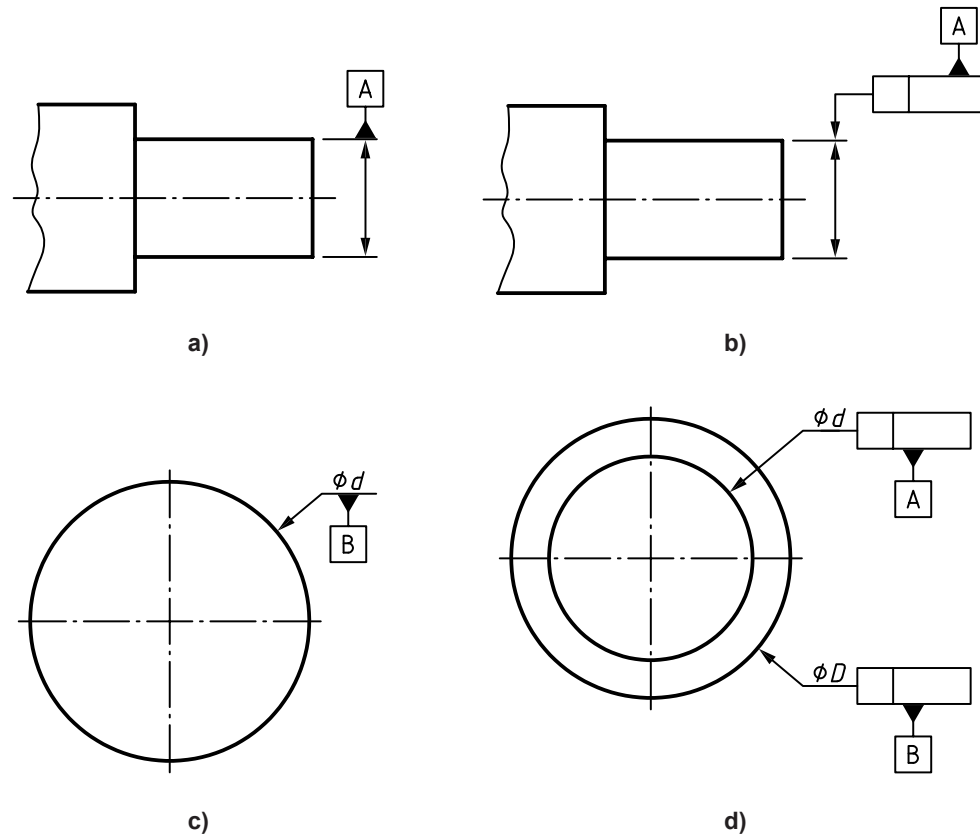

Figure 18 — Attachment of a datum indicator for a single feature considered a feature of size

If the single feature is a helical surface (e.g. a screw) or a complex surface (e.g. a cylindrical gear), it is considered a cylindrical surface. To establish the datum, the datum feature indicator shall be designated as indicated in 7.2.1. If there is no complimentary indicator, the datum is established from a pitch cylinder having the pitch diameter of the single feature and the modifier [PD] can be omitted. When the datum is established from a major cylinder (having the major diameter of the single feature) or a minor cylinder (having the minor diameter of the single feature), the symbol [MD] or [LD], respectively, is placed in the proximity of the datum indicator.

Where the single feature used for establishing a datum is not a feature of size, the surface shall be designated by a datum indicator placed either

- on the outline of the surface [see Figure 19 a), datum feature identifier A],
- on an extension line of the surface [see Figure 19 a), datum feature identifier B],
- on a tolerance frame pointing to the outline or extension line of the surface or on a reference line [see Figure 19 b)], or
- on a reference line with a leader line, that does not relate to a dimension, attached to the surface, terminating in a filled circle [see Figure 19 d)] or in an open circle when the surface is hidden [see Figures 19 c)]. A datum indicator on a view where the surface is not hidden (see Figure 19) should be indicated.

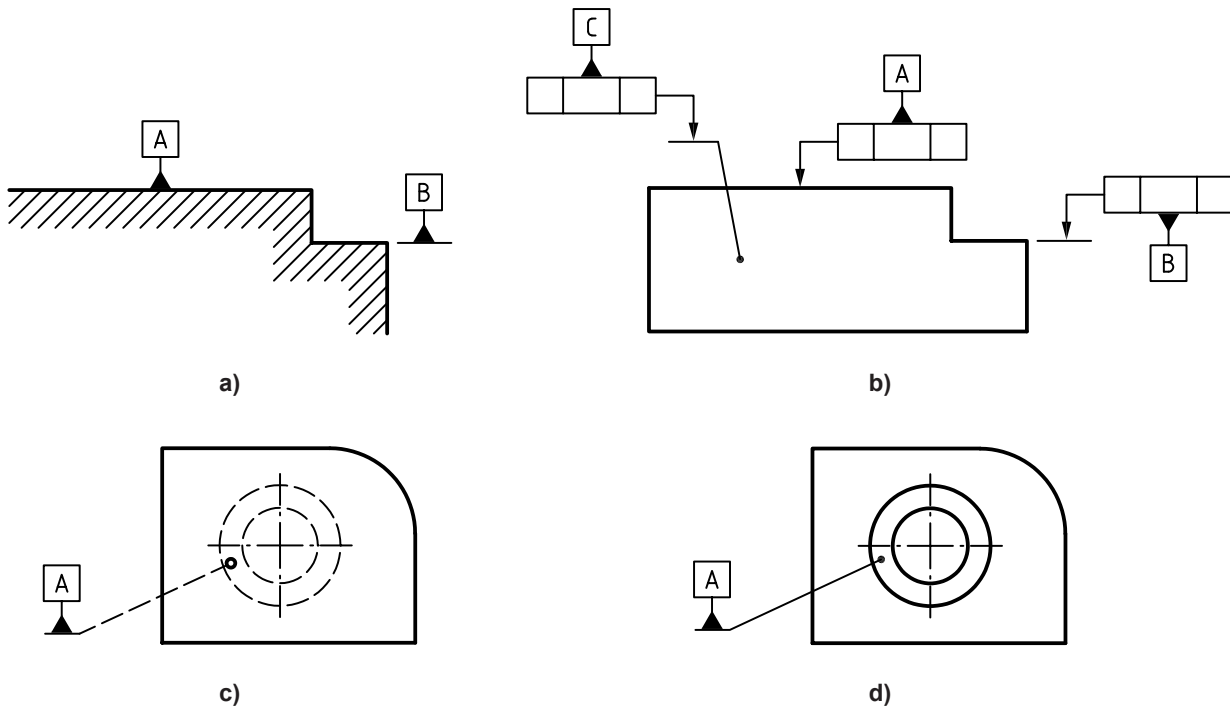

Figure 19 — Attachment of a datum indicator for a single feature not considered a feature of size

When the surface is hidden, the leader line or reference line shall be dashed and terminated by an open circle [see Figure 19 c)].

NOTE 1 The meaning of a datum indicator attached to a tolerance frame for a single feature that is a feature of size is identical to that of a datum indicator identifying a feature of size placed in any other permitted manner (see Figure 18).

NOTE 2 See example C.1.1 for a feature which is not a feature of size and example C.1.2 for a feature which is a feature of size.

7.4.2.2 Rule 2 — Associated features of size with fixed or variable size

If the intrinsic characteristic of a feature of size used to establish a datum is theoretically exact for the association, its value shall be identified by a TED (with the exception of an implicit TED).

If the intrinsic characteristic of a feature of size used to establish a datum is variable for the association, it shall be identified by a direct or general (default) tolerance.

If the value of the intrinsic characteristic is omitted, and is not an implicit TED, then it shall be considered as defined in Table 3 for association.

The implicit TED of an intrinsic characteristic can only have the values of 0 mm, 0°, 90°, 180° and 270° and is not indicated.

NOTE 1 See example C.1.3 for a theoretically exact intrinsic characteristic and example C.1.2 for a variable intrinsic characteristic.

NOTE 2 More information on general (default) tolerances is given in ISO 2768-1 and ISO 2768-2.

7.4.2.3 Rule 3 — Datum features established from a complete feature

If a datum is established from a complete integral feature, it shall be indicated with a datum indicator only.

NOTE See Figure 23 a) and C.1.1.

7.4.2.4 Rule 4 — Datum features established from one or more datum targets

If a single datum feature is established from one or more datum targets belonging to only one surface, then the datum feature identifier identifying the surface shall be repeated close to the datum indicator, followed by the list of numbers (separated by commas) identifying the targets (see Figure 20). Each individual datum target shall be identified by a datum target indicator, indicating the datum feature identifier, the number of the datum target and, if applicable, the dimensions of the datum target.

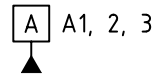

Figure 20 — Indication of datums established from datum targets

If there is only one datum target, the drawing indication may be simplified by placing the datum indicator in accordance with rule 1 for a feature of size:

- on a long-dashed dotted wide line (type 04.2 of ISO 128-24:1999) defining the portion of the considered surface [see Figure 21 a)];
- on the reference line of a leader line pointing to a hatched area surrounded by a long-dashed double-dotted narrow line (type 05.1 of ISO 128-24:1999) [see Figure 21 b)];
- by indicating [ACS] above the tolerance frame [see Figure 22 a)] or after the datum letter symbol in the tolerance frame [see Figure 22 c)], allowing the datum feature to be defined as any cross-section of the integral feature (concurrently with the toleranced feature). When [ACS] is indicated above the tolerance frame, the toleranced feature and the datum feature are established in the same cross-section.
- by indicating [ALS] above the tolerance frame [see Figure 22 b)] or after the datum letter symbol in the tolerance frame [see Figure 22 c)], allowing the datum feature to be defined as any longitudinal section of the integral feature (concurrently with the toleranced feature). The datum feature is the intersection of the real integral feature used to establish the datum and the section plane.

NOTE 1 See C.1.11.

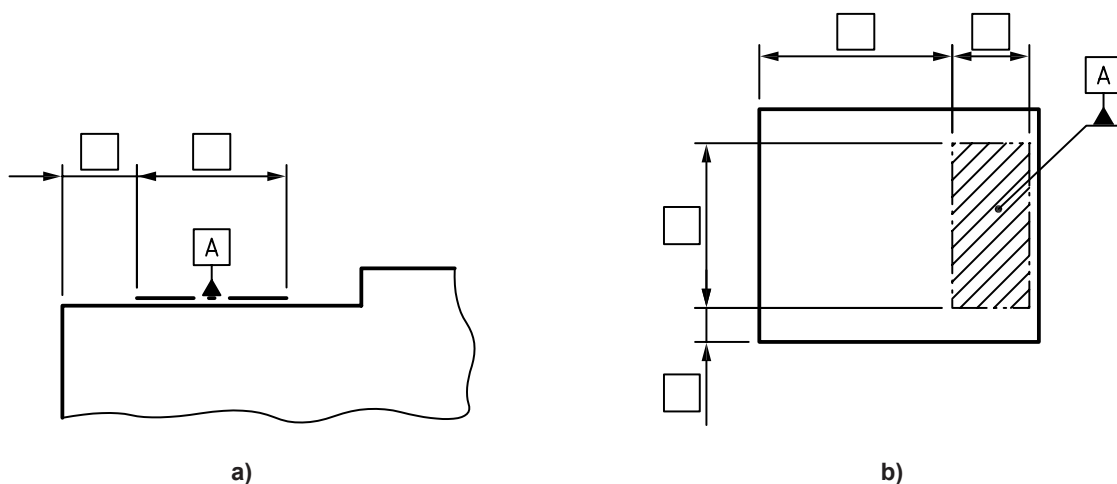

Figure 21 — Simplification of drawing indication when there is only one datum target area

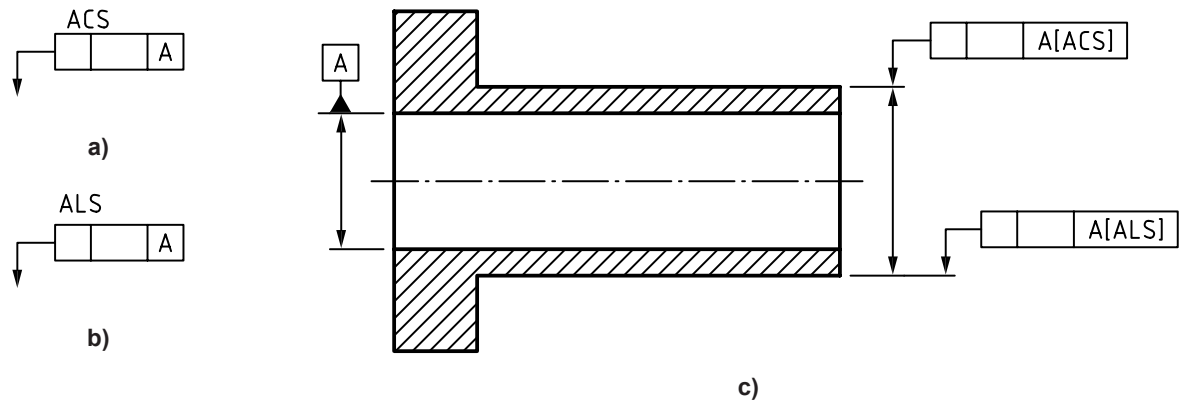
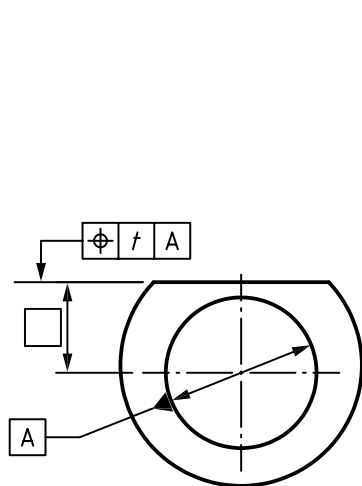

Figure 22 — Indication of [ACS] and [ALS] modifier

The relative location of datum targets on one single feature shall be defined by angular and/or linear TED(s) when it shall be considered fixed.

When a set of datum targets is used to simulate a feature of size, the number and the location of the datum targets shall be adequate to simulate its size and the relative location shall be defined by a linear or angular TED [see Figure 23 b)]. Where datum targets are located from another feature, linear TED are required [see Figure 23 c)].



NOTE The associated feature used to establish the datum from the complete integral feature is a cylinder and the datum is its axis.

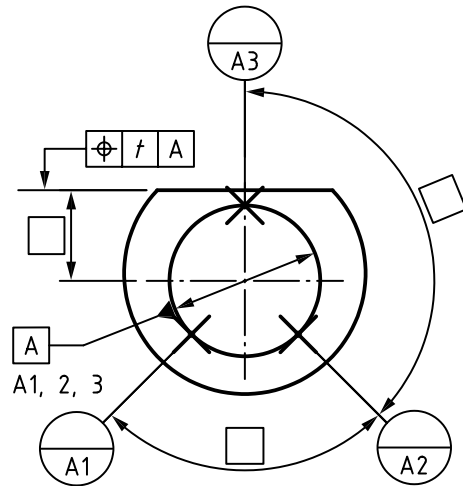

NOTE The angular locations between the datum target lines A1, A2 and A3 are indicated by TEDs and are considered as fixed. The associated feature used to establish the datum from 3 datum target lines is a cylinder and the datum is its axis.

(To fully define datum target lines A1, A2 and A3 more than one drawing view is required.)

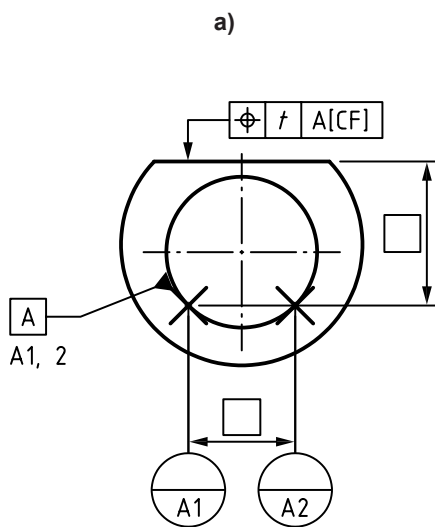

NOTE The distance between datum targets A1 and A2 is indicated by a TED and is fixed. The associated feature used to establish the datum is not a cylinder and the datum is not its axis. The datum consists of two planes: one plane through two datum target lines and a second perpendicular median plane.

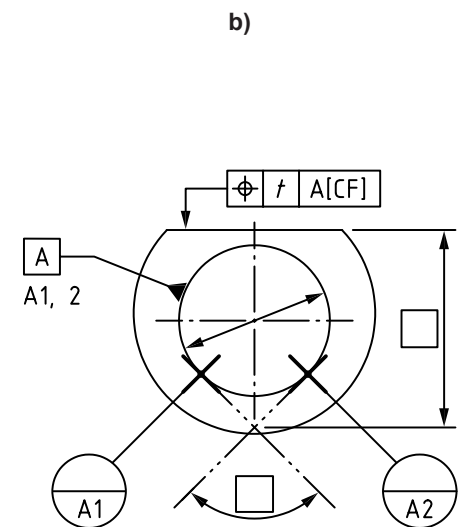

NOTE The datum targets A1 and A2 are defined by the interface between the cylinder A and a contacting feature. The distance between datum targets A1 and A2 is variable. It depends of the actual diameter of the cylinder and the contacting feature defined in this case by a "V" block of angle α . The associated feature used to establish the datum is the "V" block, not a cylinder.

Figure 23 — Examples of single datums established from a complete cylinder, a portion of a cylinder or with a contacting feature

When the location of a datum target is not fixed, the datum target shall be specified by using

- one or more contacting features, when the contact zone cannot be predetermined [see rule 5 and Figure 23 d)] (implicit datum targets can exist when datum targets are defined without ambiguity by the definition of a contacting feature and the interface of the datum feature), or
- a moveable datum target (see E.3) when the distance between that datum target and other datum targets on the same surface is not fixed but their location relative to other datum features is defined.

When two or more moveable datum targets are used for one datum, they move synchronously.

For example, when three distinctive points on a cross section of a cylinder are used as the datum target point to establish a datum, only the angular relation between these three points on the cylinder needs to be defined. The moveable modifier, pointing in the direction normal to the cylinder, can be added or omitted in this case (no distances from other features are implicated in the relation).

When only two points on a cross section of a cylinder with fixed distance between them are used as datum target points, a TED between these two points needs to be indicated. The associated feature in this case is not a cylinder but two perpendicular planes.

The location of a datum target relative to one or more other features shall be considered fixed and shall be defined by a TED. Exceptions exist, for example when moveable modifiers are not used.

When the location of a datum target on one feature relative to another feature is not fixed in a particular direction (other than normal to the surface profile), and when the [ACS] modifier is not used, then the datum target shall be defined as a moveable datum target (indicated with the “moveable” modifier in the datum target indicator) to indicate the direction in which the distance between the features is variable.

When the location of a datum target is defined in a cross section with a variable location on one feature, is not fixed in a particular location relative to another feature, and is available in any cross section, then the [ACS] modifier shall be used.

The beginning and the end of the location of a datum target line shall be considered theoretically exact locations and defined by TEDs.

The extent of a datum target area shall be considered theoretically exact. The dimensions of the area shall be indicated

- either in the upper compartment of the datum target indicator when the area is circular, square (see Figure 24), or rectangular, or placed outside and connected to the appropriate compartment by either a leader line or by a leader line and a reference line if the space within the compartment is limited [see Figure 25 a)], or
- directly on the drawing by TEDs when the area is neither square nor circular [see Figure 25 b)].

NOTE 2 In the case of a point or a line, it may be necessary to indicate the datum target on several views in order to have an unambiguous definition.

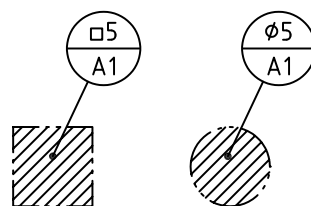

Figure 24 — Indication of dimension of a circular/square area

Dimensions in millimetres

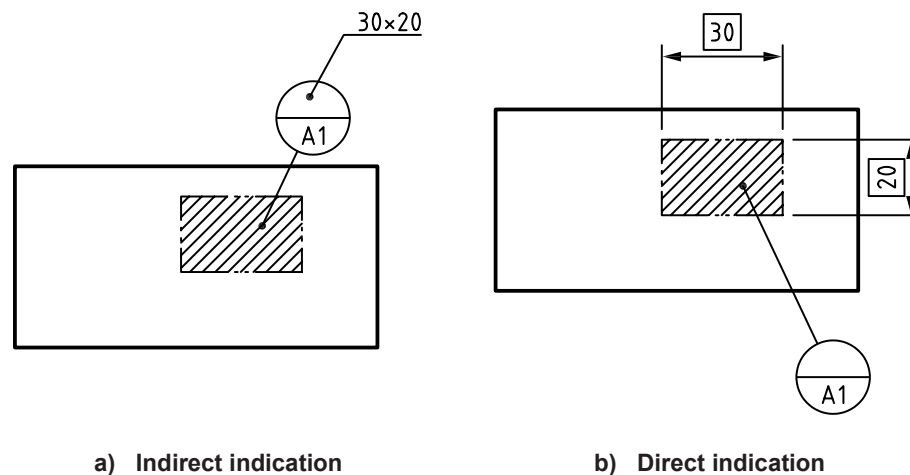

Figure 25 — Indication of dimensions of a rectangular area

7.4.2.5 Rule 5 — Associated feature with a different type than the nominal datum feature

If the associated feature establishing the datum is not of the same type as the nominal feature, datum targets shall be used and the indication [CF] shall be added in the tolerance frame after the datum feature identifier (see Figures 26 to 30).

The dimensions of the contacting feature shall be considered fixed and shall be indicated on the drawing, when it is not implicit, by drawing the contacting feature with a long-dashed double-dotted narrow line in contact with the datum feature.

NOTE 1 The modifier [CF] implies that some portions of the workpiece are used to establish the datum and that the location of the contact between the contacting feature and the workpiece cannot be determined exactly (it depends on the dimensions and the geometry of the real workpiece); see examples in Annex E. The modifier [CF] allows some dimensions between the datum targets on a single feature to become variable (see Figure 27). The datum targets may be omitted when they do not reduce the potential contact between the contacting feature and the workpiece (see Figure 30).

NOTE 2 Datum targets are used to express the nominal contact between the contacting features and the surface of the workpiece used to establish the datum. In some cases, the datum target can be omitted.

EXAMPLE In Figure 26, the datum A with modifier [CF] is a set of two perpendicular planes and not the axis of a cylinder. The first plane contains the datum target points; the second plane is the median plane of the datum target points, perpendicular to the first one. This median plane contains the set of axes of possible associated cylinders (with variable diameters) from the datum target points. If the modifier [CF] had not been used, the datum A would have been the axis of the associated cylinder (with a variable diameter or with a fixed diameter depending on the application of Rule 2).

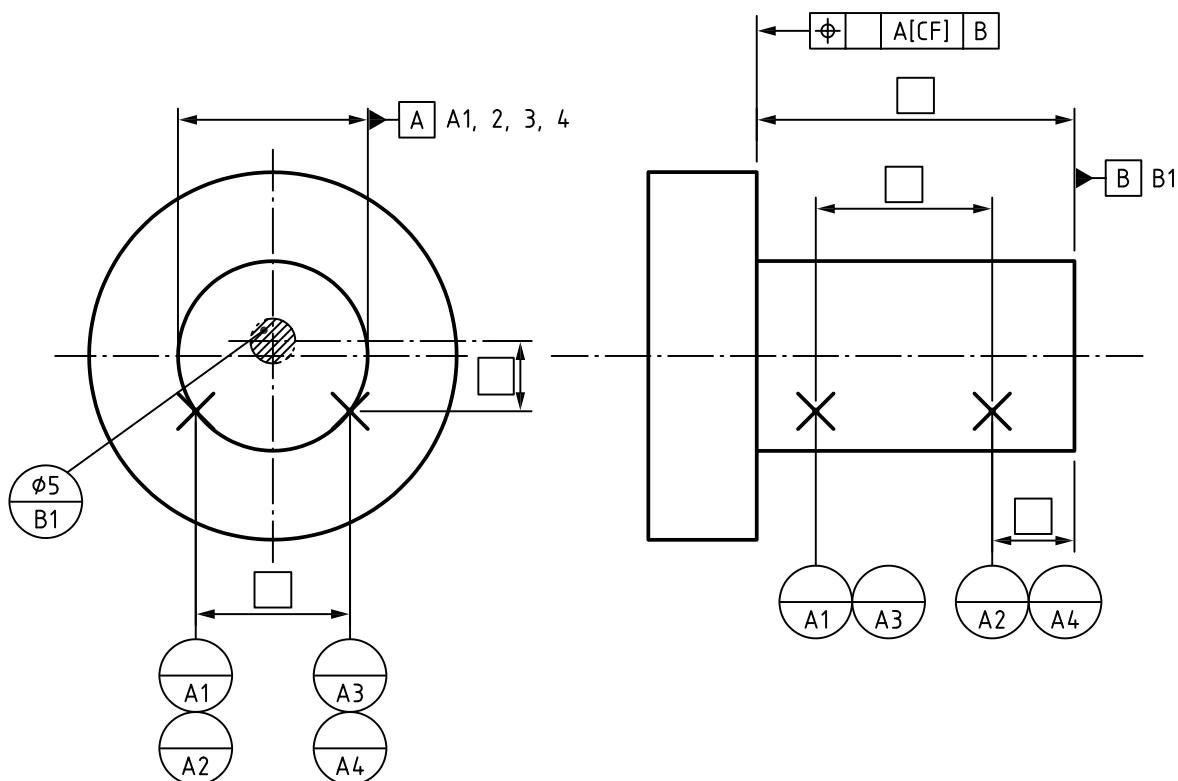

Figure 26 — Example of indication of datum with modifier [CF]

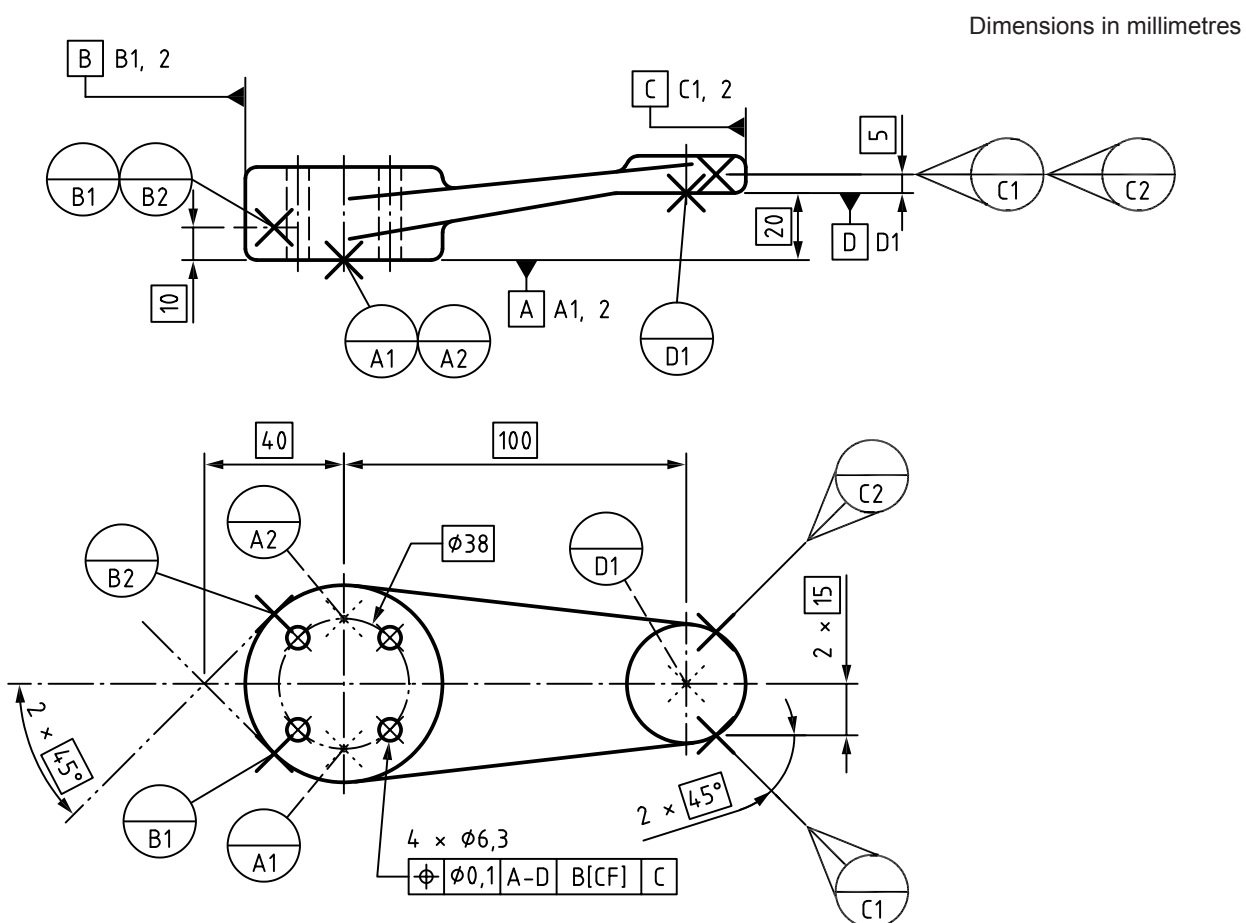

Figure 27 — Example of datum system established from datum targets

NOTE 3 In Figure 27, the distance between the datum targets B1, B2 and C1, C2 is unknown. Therefore, C1 and C2 are defined as moveable datum targets in relation with datum targets B1 and B2. C1 and C2 move synchronously.

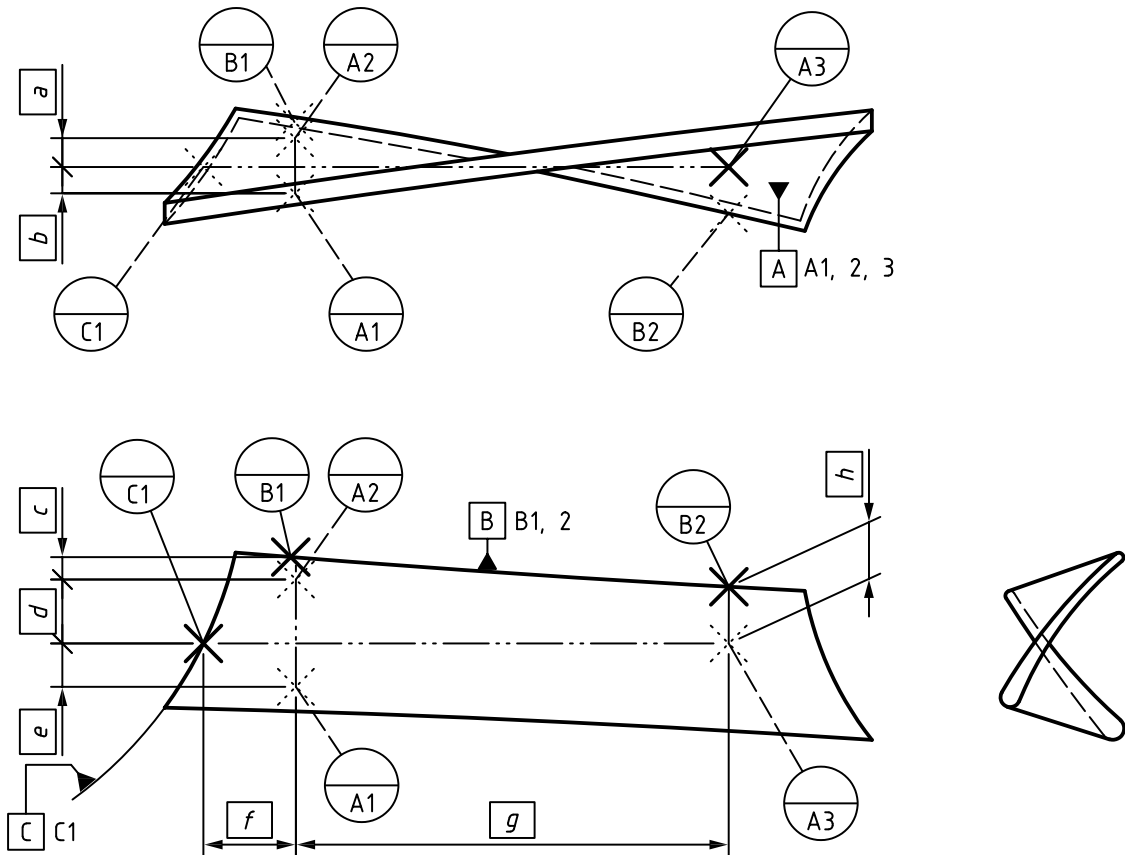

Figure 28 — Example of indications of datum targets on complex surfaces

Dimensions in millimetres

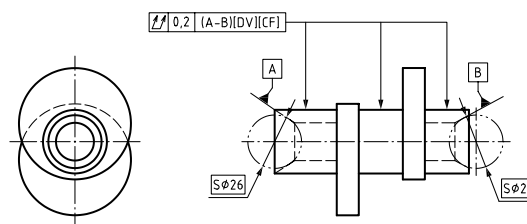

Figure 29 — Example of datum system in which the datum target indication is omitted

Dimensions in millimetres

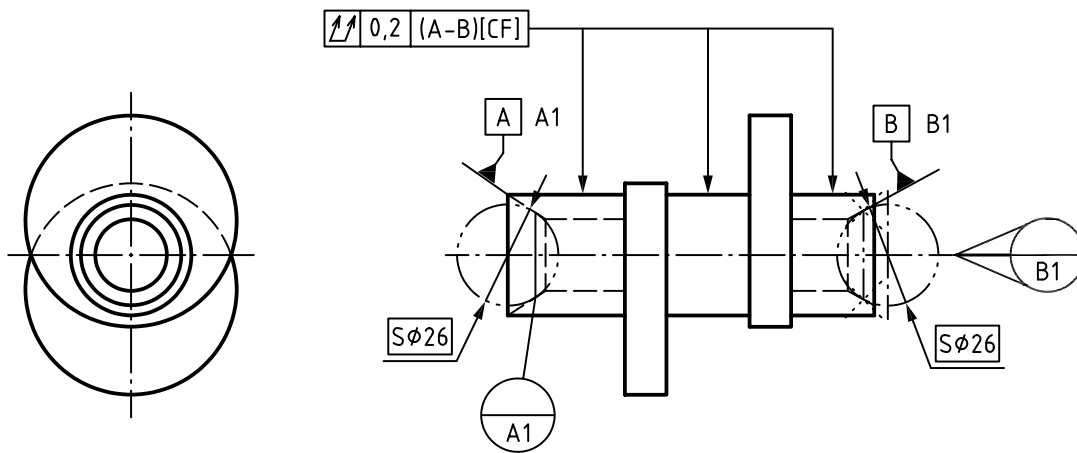

Figure 30 — Example of datum system in which the datum target is indicated

7.4.2.6 Rule 6 — Tolerance frame layout with a datum or a datum system

If the tolerance frame has only three compartments, only a single datum or a common datum used as a primary datum is specified [see Figures 31 a) and 31 b)].

If the tolerance zone is oriented or located from only one datum established from a single feature, then the tolerance frame shall only have three compartments and the single datum shall be indicated in the third compartment [see Figure 31 a)].

If the tolerance zone is oriented or located from only one datum established simultaneously from more than one single feature, then the tolerance frame shall only have three compartments and the common datum shall be indicated in the third compartment [see Figure 31 b)].

If the tolerance zone is oriented or located from more than one datum established in a specific order, then the tolerance frame shall have more than three compartments and each compartment after the second compartment shall indicate a single or common datum [see Figures 31 c) to 31 e)]. The specified order defines the orientation constraints between the primary, secondary and tertiary datums (single or common). The value of the constraints shall be specified by TEDs. TED values of 0°, 90°, 180° and 270° are implicit and not indicated.

NOTE 1 In a datum system, the primary datum is identified in the third compartment of the tolerance frame; the secondary datum is identified in the fourth compartment of the tolerance frame; the tertiary datum is identified in the fifth compartment of the tolerance frame.

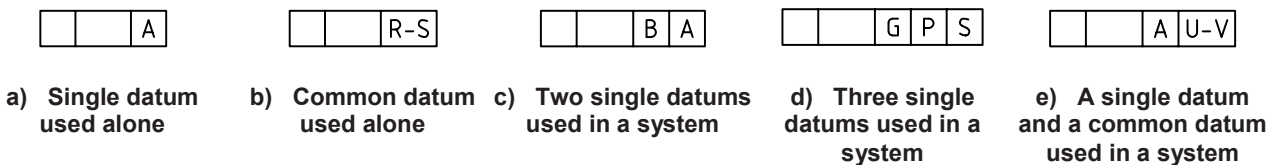

Figure 31 — Examples of indication of datums in the tolerance frame

NOTE 2 See C.1 and C.2 for examples where there are only three compartments in the tolerance frame and C.3 for examples where there are more than three compartments in the tolerance frame.

7.4.2.7 Rule 7 — Indication of a single or common datum in a compartment of a tolerance frame

When the datum is a single datum, it shall be indicated by one datum letter in a compartment of the tolerance frame [see Figures 31 a), 31 c), 31 d) and 31 e)].

When the datum is a common datum, it shall be indicated by a sequence of datum letters separated by hyphens in a compartment of the tolerance frame [see Figures 31 b) and 31 e)].

The datum letters given in the tolerance frame shall be the same as the letters given in the datum indicators.

In the case of a common datum, the following points apply.

- The associated features that establish a common datum are by default constrained in location and orientation to each other. *If the modifier [DV] is placed in the tolerance frame after the letter(s) identifying a common datum, then the linear distance between the members of the collection of features that make up this common datum shall be considered variable.*
- The orientation and location constraints correspond to the intrinsic characteristics introduced by the collection of features and are specified by TEDs. The values of 0 mm, 0°, 90°, 180° and 270°, and equally divided linear or angular dimensions may be implicit TEDs and not indicated.
- There are as many datum feature identifiers in the tolerance frame as single features used for establishing the common datum, unless a simplified indication is used.
- The sequence of the letters identifying the common datum has no significance.
- It is possible to simplify the drawing indication by
 - using only one datum indicator,
 - using only one doubled letter separated by a hyphen in the tolerance frame [(see Figure 32 d)], and
 - adding the complementary indication “ $n \times$ ” giving the number, n , of surfaces in the collection on the right side of a datum indicator attached to one of the surfaces [see Figure 32 a)]. When the datum indicator points to the tolerance frame, the indication “ $n \times$ ” is not written on the right side of a datum indicator but above the tolerance frame [see Figure 32 b)], or, when the datum indicator points to the tolerance frame, by using leader lines indicating each surface included in the common datum [see Figure 32 c)].

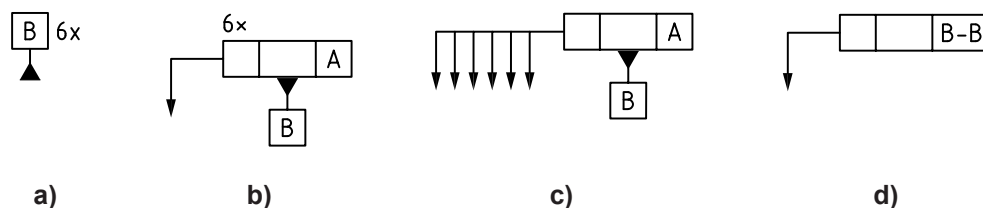

Figure 32 — Examples of complementary indication

NOTE See the examples given in C.1 for single datums and in C.2 for common datums. See the example in C.2.5 for the simplified drawing indication.

7.4.2.8 Rule 8 — Locked or released degrees of freedom from a datum

If all situation features of a single or common datum are required to lock all possible degrees of freedom of the tolerance zone in relation to the geometrical characteristic, no further indication (PL, SL, PT, ><) shall be added after the datum letter symbol in the relevant compartment of the tolerance frame (see Annex B).

If all the situation features of a single or common datum and/or the location from a datum are not required, a complementary indication (PL, SL, PT, ><) shall be added after the datum letter symbol in the relevant compartment of the tolerance frame, except when it is obvious from the specification which situation feature is to be used:

- *the complementary indication is [PL] if the plane (situation feature) is needed (see Figures 33 and 36);*
- *the complementary indication is [SL] if the straight line (situation feature) is needed (see Figures 34 and 36);*
- *the complementary indication is [PT] if the point (situation feature) is needed (see Figure 35);*
- *the complementary indication is >< if the datum is only used to lock the orientation degrees of freedom and not the location (see Figure 37). The >< symbol shall be omitted when the geometrical characteristic only controls the orientation of the feature (e.g. a perpendicular specification).*

NOTE 1 By default, when a datum is established on a complex surface for example, the datum consists of a plane, a straight line and a point. The modifier [SL], [PL] or [PT], or a combination thereof, can be attached to the datum letter to limit the situation feature(s) obtained from the surface.

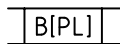

Figure 33 — Indication when only the plane is needed in the set of situation features

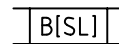

Figure 34 — Indication when only the straight line is needed in the set of situation features



Figure 35 — Indication when only the point is needed in the set of situation features

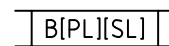
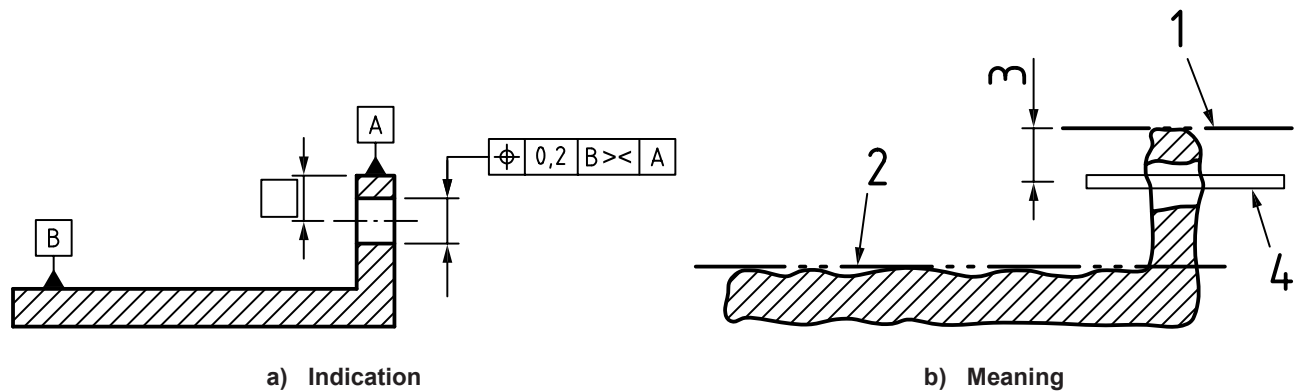

Figure 36 — Indication when only the plane and the straight line are needed in the set of situation features



Key

- 1 associated plane with outside material constraint and with orientation constraint from datum B
- 2 associated plane with outside material constraint (datum B)
- 3 distance relative to the location
- 4 tolerance zone with orientation constraint from datum B and location constraint from datum A

NOTE The modifier \gg allows only the orientation degrees of freedom of the tolerance zone and not its translation degree of freedom (managed by the datum A, in this case) to be locked from the datum B.

Figure 37 — Example of datum with the \gg modifier

NOTE 2 See the examples in C.1.5 where all the situation features are needed, example C.1.6 for obvious situation feature and example C.1.7 where only one situation feature is needed.

7.4.2.9 Rule 9 — Special indications for common datum

When a complementary indication (CF, SL, PL or PT) applies to all elements of the collection of surfaces of a common datum, the sequence of letters identifying the common datum shall be indicated within parentheses [(see Figure 38 a)].

When a complementary indication (CF, SL, PL or PT) applies only to one element of the collection of surfaces of a common datum, the sequence of letters identifying the common datum shall not be indicated within brackets, and the complementary indication applies only to the feature identified by the letter just before the indication(s)[see Figure 38 b)].

If the linear distance between the members of the collection of features that make up a common datum shall be considered variable, then the modifier [DV] shall be placed in the tolerance frame after the letter(s) identifying the common datum [see Figure 38 c)].

NOTE See example E.4.

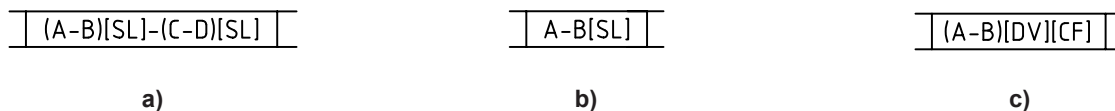

Figure 38 — Complementary indications for common datums

7.4.2.10 Rule 10 — Application of geometrical modifiers in a tolerance frame

If the modifier \textcircled{M} , \textcircled{L} or \textcircled{P} is placed in the tolerance frame after the letter, then the default meaning changes.

If one of the modifiers \textcircled{M} or \textcircled{L} is placed in the tolerance frame after the letter indicating a datum, the datum shall be established in accordance with ISO 2692.

When the modifier \textcircled{P} is placed in the tolerance frame after the letter indicating a datum established from a feature of size, then the datum feature shall be established by fitting an associated feature of the projected length to the extension of the real feature by considering the criteria defined in Annex A and not the real integral feature itself.

When using the modifier \textcircled{P} , the extension of the feature shall be indicated, directly on the drawing (see Figure 39) or after the modifier \textcircled{P} in the tolerance frame. The dimension(s) of this extension shall be seen as a TED.

NOTE The modifier \textcircled{P} can be applied to a secondary or tertiary datum. In Figures 39 and 40, the effect of this modifier is shown when the datum is a secondary datum in a datum system. The modifier has no effect when it is applied to a primary datum, and the same association criteria are used to define the projected datum feature and to determine the datum.

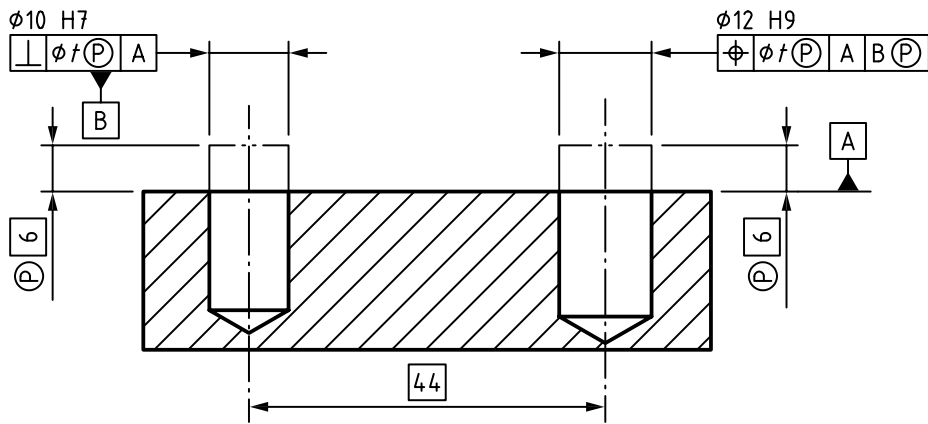
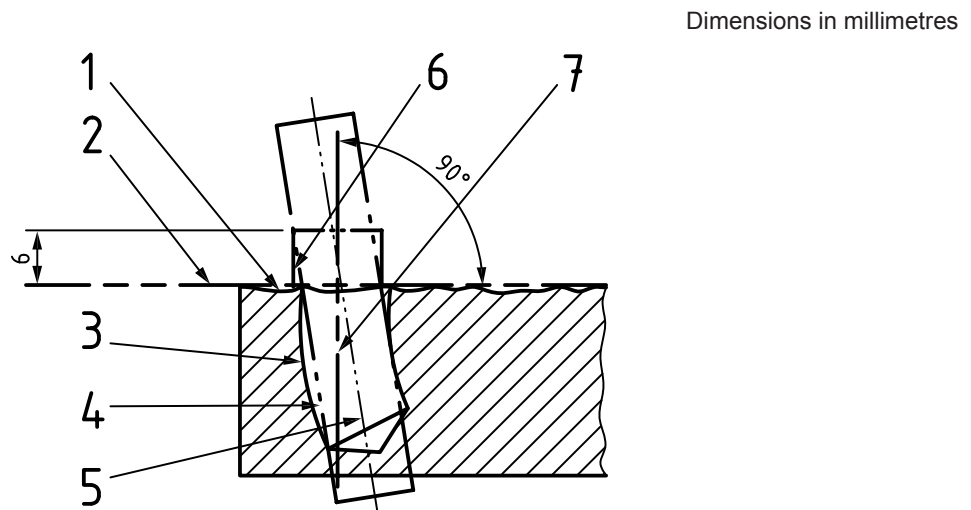

Figure 39 — Example of application of modifier \textcircled{P} on the secondary datum



Dimensions in millimetres

Key

- 1 real integral feature of the planar surface
- 2 datum A: an associated integral feature to 1
- 3 real integral feature of the cylindrical surface
- 4 associated integral feature to 3
- 5 derived feature of 4
- 6 associated integral feature to the portion of 4, with the constraint perpendicular to 2
- 7 datum B: the derived feature of 6 (as a secondary datum)

Figure 40 — Meaning of the specification given in Figure 39

Annex A (normative)

Association for datums

A.1 Basic concepts

Association methods for datums relate the real features to the datums and to an unambiguous set of constraints that lead to the identification of unique datums or datum systems.

To establish an associated feature, it is necessary to perform a partition, an extraction, a filtration and finally an association (see Figure A.1).

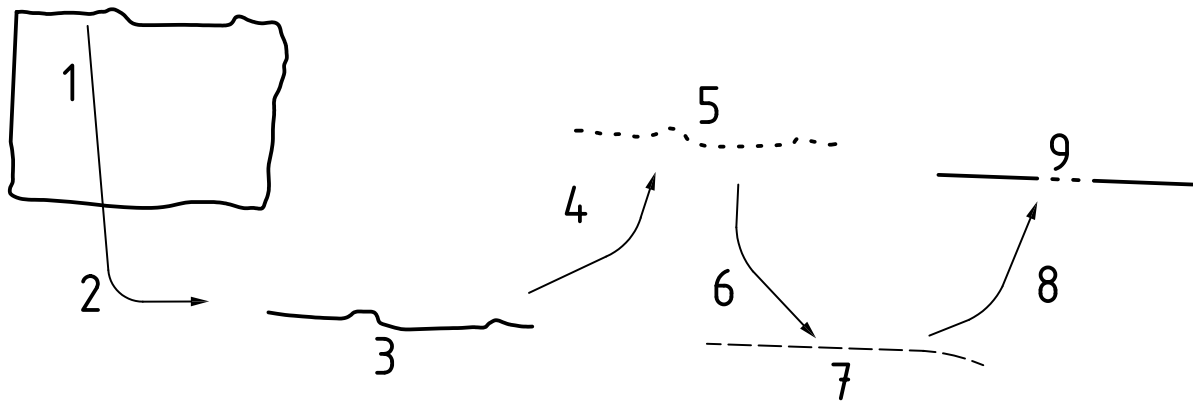

Key

1	real workpiece	4	extraction	7	filtered feature
2	partition	5	extracted integral feature	8	association
3	real integral feature	6	filtration	9	associated feature

Figure A.1 — Example of procedure to establish an associated feature

Association methods for datums are defined independently of partition, extraction and filtration. The relevant methods for partition, extraction and filtration are not defined in this International Standard.

The filtration shall retain the highest points in the real integral feature. For a flat or convex nominal feature, such as a shaft, the filtration shall result in a convex feature (see Figure A.2). For other types of nominal feature, such as a hole, voids in the surface shall similarly be removed (see Figure A.3). The filtration is otherwise not defined in this International Standard

NOTE It is envisioned that the details of the filtration will be elaborated in the next version of this International Standard.

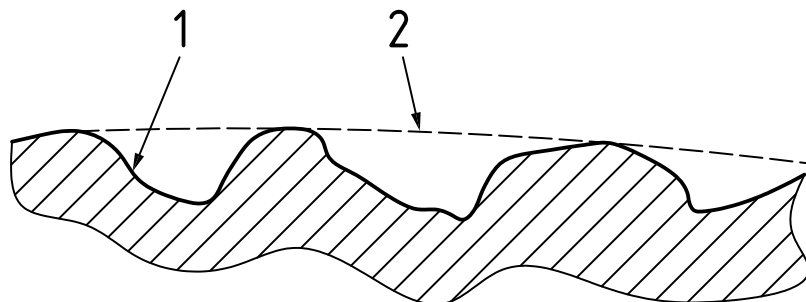

Key

- 1 real integral feature
- 2 filtered feature

Figure A.2 — Illustration of filtration applied to a nominally flat surface

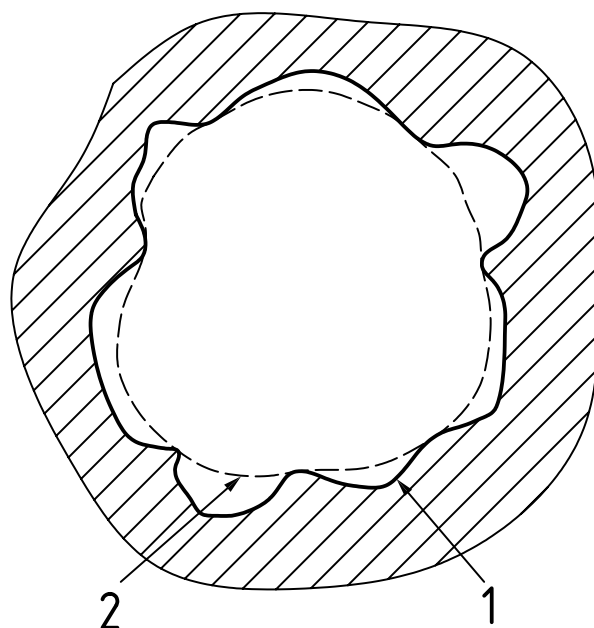

Key

- 1 real integral feature
- 2 filtered feature

Figure A.3 — Illustration of filtration applied to a nominally cylindrical surface

The default association criterion (objective function with or without constraints), used for the association of datums, is meant to simulate the contact between a surface having a perfect shape and the non-ideal surface. This perfect contact surface is by default of the same type as the nominal surface. There are cases where the associated surface, used to establish the datum, is not of the same type as the nominal datum feature (e.g. when simulating contacting features – see rule 5).

A.2 Association methods

A.2.1 General

The associated features, used to establish the datums or datum systems, simulate contact with the real integral features in a way that ensures that the associated feature is outside the material of the non-ideal feature. When the result of this process is not unique, then the associated feature to be used is the one that minimizes the maximum distance normal to the associated feature between the associated feature and the filtered feature representing the real feature (see Figure A.4).

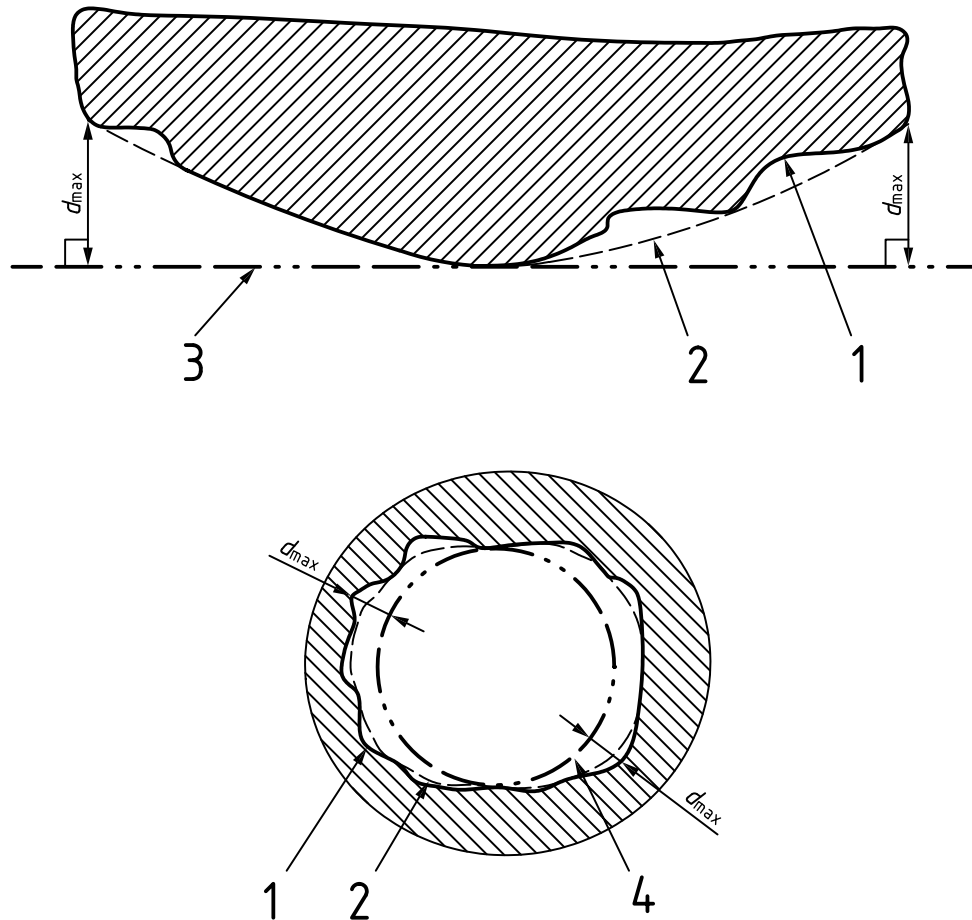

Key

- 1 real integral feature
- 2 filtered feature
- 3 outside material tangent plane minimizing the maximum distance (d_{max}) with the filtered feature
- 4 maximum inscribed cylinder minimizing the maximum distance (d_{max}) with the filtered feature

Figure A.4 — Examples of associated features (for a planar surface and a cylindrical surface)

When the datum is established from a feature of size whose intrinsic characteristic (size) is linear, this intrinsic characteristic shall be considered:

- variable (rule 2), if contact between the associated feature and the real feature is required [see Figure A.5 a)], or
- fixed (rule 2), if contact between the associated feature and the real feature is not required [see Figure A.5 b)].

When the datum is established from a feature of size whose intrinsic characteristic (size) is angular, contact between the associated feature and the real feature is required.

A.2.2 Association for single datums

A.2.2.1 Association for single datums without the [CF] modifier

Only one ideal feature or feature of size (of the same type as the nominal feature) shall be fitted to the indicated non-ideal surface when the modifier [CF] is not specified after the datum letter in the tolerance frame [see Figures A.5 a) and A.5 b)].

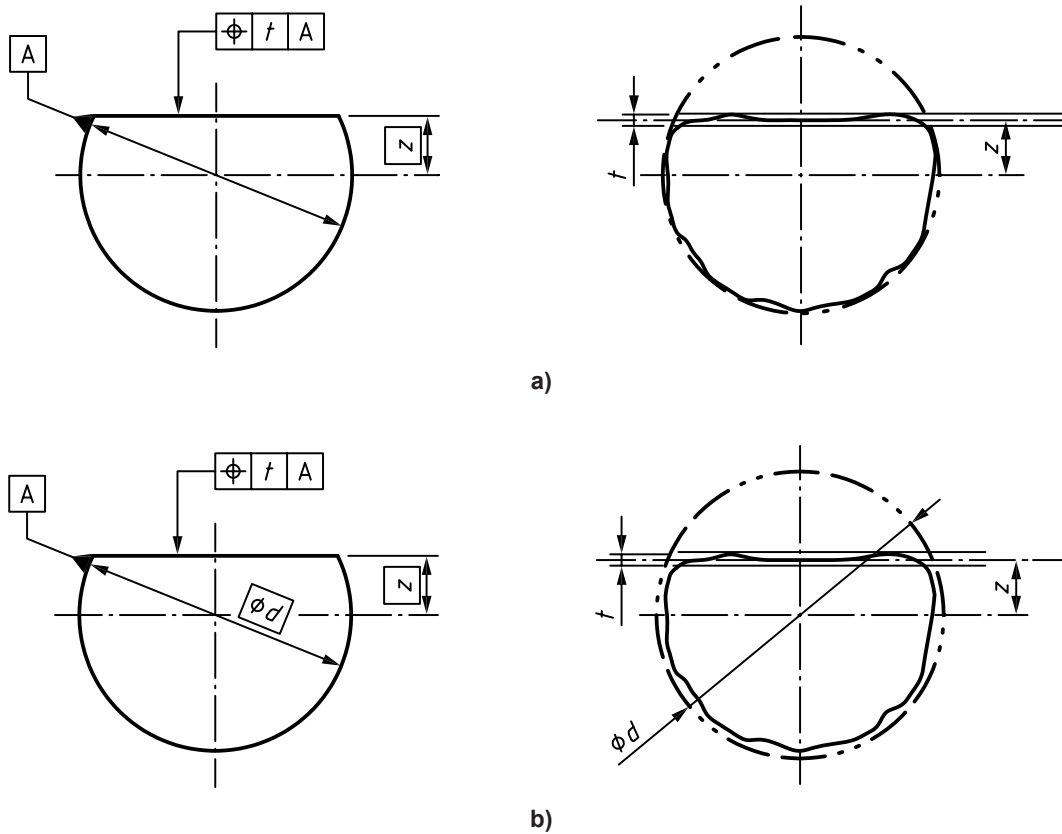

NOTE When associating a cylinder of fixed size, the maximum distance between the associated cylinder and the real (extracted) cylinder is minimized, without orientation, location and material constraints.

Figure A.5 — Examples of single datums established on a nominally cylindrical surface, without [CF] (contacting feature) modifier, used in a geometrical specification

A.2.2.2 Association for single datums with the modifier [CF]

When the modifier [CF] is specified after the datum letter in the tolerance frame, it is necessary:

- to identify the contacting features used to define the interface (1) between these contacting features and the datum feature;
- to identify the ideal feature type (2) of the contacting features;
- to associate an ideal feature to the interface [defined above as (1)]. The type of the ideal feature is a plane, a straight line, a point or a collection of these [depending on the type defined above as (2)] [see Figure A.6)].

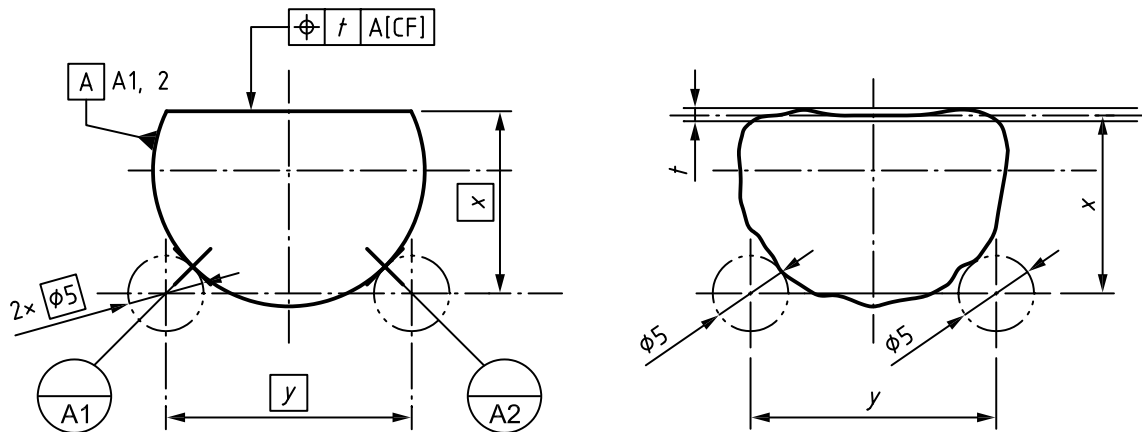

Figure A.6 — Examples of single datums established on a nominally cylindrical surface, with [CF] (contacting feature) modifier, used in a geometrical specification

A.2.2.3 Default association criteria

When a single datum is established from a feature of size and its size is considered variable for the association (e.g. a cylinder, a sphere, two parallel planes or a torus), the default association criteria is given in Table A.1.

When a single datum is established from a feature of size and its size is considered fixed for the association (e.g. a cone or a wedge), the default association criterion is to minimize the distance between the datum feature and the associated feature (in this particular case, the material constraint is not applied between the associated feature and the datum feature).

The distance to be minimized is in all cases normal to the associated feature.

When a single datum is established from a plane or a complex surface (which are not features of size) or from a cone or a wedge (which are features of size, with angular size), the default association criterion is given in Table A.2.

When a single datum established from a conical surface is considered variable for the association, the default association criterion is to minimize the distance between the datum feature and the associated feature with the outside material constraint and fixed intrinsic characteristic constraint.

Table A.1 — Default association criteria for a feature of size with variable intrinsic characteristics

Drawing indication referencing a datum established from this nominal type of geometrical feature	Internal/ External	Default association criteria for single datums established from a feature of size with variable intrinsic characteristic constraint		Situation feature
		Objective function	Material constraint	
Sphere	Internal	Maximum inscribed: Maximize the diameter of the associated inscribed sphere in the datum feature ^a .	Outside the material	The centre of the associated sphere (point)
	External	Minimum circumscribed: Minimize the diameter of the associated circumscribed sphere in the datum feature ^a .		
Cylinder	Internal	Maximum inscribed: Maximize the diameter of the associated inscribed cylinder in the datum feature ^a .	Outside the material	The axis of the associated cylinder (straight line)
	External	Minimum circumscribed: Minimize the diameter of the associated circumscribed cylinder in the datum feature ^a .		
Two parallel planes	Internal	Maximum inscribed: Maximize the distance between the two planes associated simultaneously to the two datum features. These two planes are constrained to be parallel to each other ^a .	Outside the material	Median plane of the two associated planes (plane)
	External	Minimum circumscribed: Minimize the distance between the two planes associated simultaneously to the two datum features. These two planes are constrained to be parallel to each other ^a .		
Torus	Internal	Maximum inscribed: Maximize the diameter of the cross-section of the inscribed torus (torus with variable diameter of directrix and fixed diameter of generator in internal contact) associated with the datum feature.	Outside the material	Plane and centre of the associated torus (plane and point)
	External	Minimum circumscribed: Minimize the diameter of the cross-section of the circumscribed torus (torus with variable diameter of directrix and fixed diameter of generator in external contact) associated with the datum feature.		

^a In cases where the linear size (of the feature of size) is considered variable, the result of the association can lead to several solutions with the same datum feature ("unstable association"). In this case, the following alternative association criterion shall be used: minimize the maximum distance normal to the associated feature between the associated feature and the datum feature or between the two associated features and the two datum features (in the case of two parallel planes).

Table A.2 — Default association criteria for a feature which is not a feature of size or for a feature of size with fixed intrinsic characteristics

Drawing indication referencing a datum established from this nominal type of geometrical feature	Internal/ External	Default association criteria for single datum		Situation feature
		Objective function	Material constraint	
Cone	Internal	Minmax: Minimize the maximum distance between the associated cone and the datum feature with fixed intrinsic characteristic constraint (fixed angle).	Outside the material	Situation features of the associated cone (straight line and point)
	External			
Wedge	Internal	Minmax: Minimize the maximum distance between the associated wedge and the datum feature with fixed intrinsic characteristic constraint (fixed angle).	Outside the material	Situation features of the associated wedge (plane and straight line)
	External			
Complex surface	Non-applicable	Minmax: Minimize the maximum distance between the associated complex surface with fixed parameters and the datum feature.	Outside the material	Situation features of the associated complex surface (plane, straight line and point)
Plane	Non-applicable	Minmax: Minimize the maximum distance between the associated plane and the datum feature.	Outside the material	The associated plane (plane)

A.2.3 Association for common datums

A.2.3.1 General

The association method for common datums requires that a collection of ideal single surfaces be fitted simultaneously (in one step) to several non-ideal surfaces.

The process of association for common datums includes location and orientation constraints between the different associated features. These constraints are the new intrinsic characteristics defined by the collection of the features. These constraints are either defined explicitly by TEDs or implicitly (implicit orientation constraint: 0°, 90°, 180°, 270° and implicit location constraint: 0 mm). The internal constraints for association described for single datums are also applicable for common datums, but complementary constraints (e.g. coplanarity, coaxiality, etc.) between the associated features shall be added.

A.2.3.2 Default association criteria

The default association criterion is defined by constraints and an objective function.

The following constraints for establishing a common datum apply to each associated feature included in the collection defined by the common datum indication:

- be outside the material of its corresponding filtered feature;
- respect the orientation and location constraints defining the relationship between the nominal features in the collection (indicated by an explicit or implicit TED), while taking into account any modifiers (e.g. [DV]).

The objective function is to simultaneously minimize the maximum distance normal to the associated feature between each associated feature and its filtered feature, as illustrated by the following formula, while respecting the default constraints (see Figure A.7).

$$\text{minimize} \left[\max_{i=1, \dots, N} d(A_i, F_i) \right]$$

where

$d(A_i, F_i)$ is the distance between the features A_i and F_i ;

i is the index of a single feature member of the collection surface for the common datum;

N is the number of single features constituting the collection surface for the common datum;

A_i is the associated feature of the filtered feature;

F_i is the filtered feature of the real integral feature.

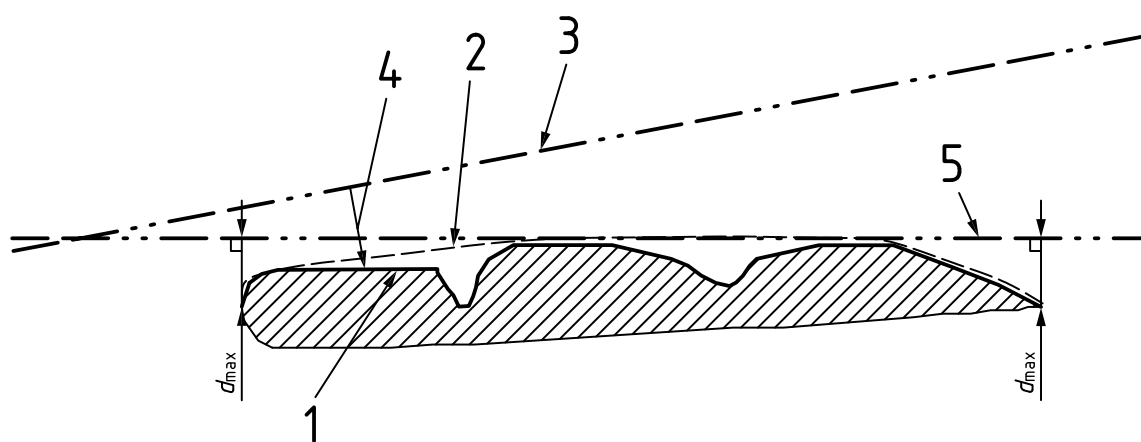

Key

- 1 real integral feature
- 2 filtered feature
- 3 ideal feature
- 4 local distance defined from the ideal feature to the filtered feature
- 5 associated feature with the objective function “minmax” and the association constraint tangent outside the material (d_{\max} is minimized)

Figure A.7 — Illustration of association process with minmax objective function and outside material constraint

Figure A.8 illustrates the process used to establish a common datum from two surfaces nominally cylindrical and coaxial.

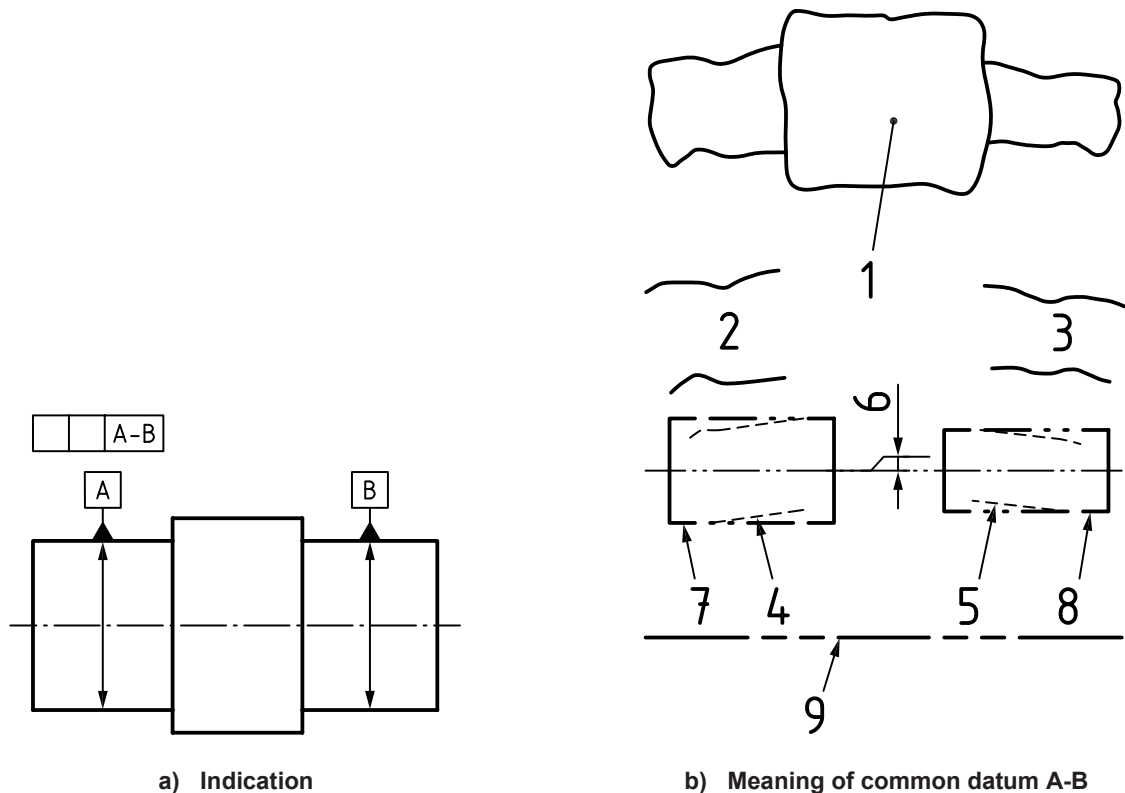

Key

- 1 real workpiece
- 2 datum feature, arbitrarily numbered N° 1 of the collection surface for the common datum
- 3 datum feature numbered N° 2 of the collection surface for the common datum
- 4 filtered feature of datum feature N° 1
- 5 filtered feature of datum feature N° 2
- 6 orientation constraint and location constraint between the associated features of the collection feature (coaxiality)
- 7 associated feature of datum feature N° 1 respecting constraint 6), variable intrinsic characteristic and outside material constraint with objective function "minmax" to minimize, simultaneously and globally, the maximum distances between the associated feature of N°1 datum feature and its filtered feature and between the associated feature of N°2 datum feature and its filtered feature
- 8 associated feature of datum feature N° 2 respecting constraint 6), variable intrinsic characteristic and outside material constraint with objective function "minmax" to minimize, simultaneously and globally, the maximum distances between the associated feature of N°1 datum feature and its filtered feature and between the associated feature of N°2 datum feature and its filtered feature
- 9 common datum (in this case, the axis of the collection surface – the two coaxial associated cylinders)

Figure A.8 — Common datum established from two coaxial cylinders

A.2.4 Association for datum systems

A.2.4.1 General

The association method for datum systems requires that a collection of ideal single surfaces be fitted in a specified order (in several steps) to several non-ideal surfaces.

A datum system is constituted by an ordered list of two or three datums. These datums (primary, secondary, tertiary) can each be a single or a common datum. The association of the surfaces to each datum feature is performed one after the other in the order defined by the system. The association of the secondary and tertiary datums respects the constraints created by the associations already carried out.

Moreover, the following supplementary constraints are required.

- The primary datum imposes orientation constraints on the secondary datum, defined by the theoretically exact relative orientation between the primary and the secondary datums.
- If a tertiary datum exists,
 - the primary datum imposes orientation constraints on this tertiary datum, defined by the theoretically exact relative orientation between the primary and the tertiary datums, and
 - the secondary datum imposes orientation constraints on the tertiary datum, defined by the theoretically exact relative orientation between the secondary and tertiary datums.

A.2.4.2 Default association criteria

The default association criterion for the primary datum is the default association criterion for a single datum or a common datum, respectively, if the primary datum is a single datum or a common datum without additional constraint.

The default association criterion for the secondary datum is the default association criterion for a single datum or a common datum, respectively, if the secondary datum is a single datum or a common datum with the additional orientation constraints from the primary datum (defined explicitly by TED angles and/or implied angles of 0°, 90°, 180° or 270°).

The default association criterion for the tertiary datum is the default association criterion for a single datum or a common datum, respectively, if the tertiary datum is a single datum or a common datum with the additional orientation constraints from the primary datum and the secondary datum (defined explicitly by TED angles and/or implied angles of 0°, 90°, 180° or 270°).

Annex B (informative)

Invariance classes

All surfaces can be classified into seven classes based on the degrees of freedom for which the surface is invariant (a collection of two or more surfaces also belongs to one of these classes).

For each class of surface, situation features (point, straight line, plane or helix) are defined.

Table B.1 — Table of invariance classes

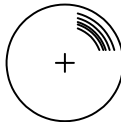
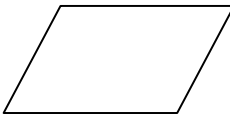
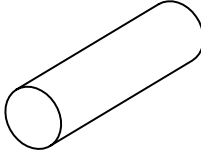
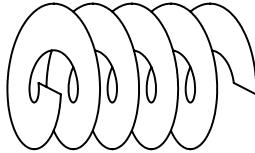
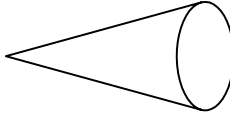
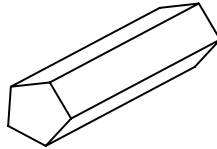
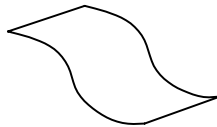
Invariance class	Unconstrained degrees of freedom	Illustration	Situation features	Example of types of surfaces
Spherical	3 rotations around a point		Point	Sphere
Planar	1 rotation perpendicular to the plane and 2 translations along 2 lines of the plane		Plane	Plane
Cylindrical	1 translation and 1 rotation around a straight line		Straight line	Cylinder
Helical	Combination of 1 translation and 1 rotation around a single straight line		Straight line ^a	Helical surface with a basis of involute to a circle
Revolute	1 rotation around a straight line		Straight line Point	Cone Torus
Prismatic	1 translation along a line of a plane		Plane Straight line	Pentagonal prism
Complex	None		Plane Straight line Point	Bezier surface based on an unstructured cloud of points in space

^a Helical surfaces as such are not considered in this International Standard. They are regarded as cylindrical surfaces because, in most functional cases where helical surfaces (threads, helical slopes, endless screws, etc.) are involved, the combined rotation and translation of the helix is not needed for datum purposes. In these cases, the pitch cylindrical surface is used for the datum; the major or minor cylindrical surface can also be considered and specified. Natively, the situation feature of a feature belonging to a helical invariance class is a helix, but in this International Standard we consider only its axis.

When a feature is used to establish a datum, it shall constrain, or lock, some degrees of freedom for the tolerance zone. The maximum number of degrees of freedom that can be constrained is equal to, or less than, six minus the invariance degree of the feature (see Table B.1).

When a datum or datum system is indicated in a tolerance frame, the number of unlocked degrees of freedom of the tolerance zone that are left free is equal to, or greater than, the invariance degree of that datum or datum system.

NOTE The term “invariance degree”, used in geometry, is the correct term for “degree of freedom” used in kinematics. The way in which these terms are used in this International Standard is such that the number of invariance degrees is equal to the number of unconstrained degrees of freedom for a given geometrical feature.

EXAMPLE 1 For a nominal cylindrical surface, used to establish a single datum, the nominal surface is invariant in two directions (a translation and a rotation), so it belongs to the “cylindrical” invariance class, and has an invariance degree of 2 (see Table B.1). The situation feature used to establish the datum from this feature is a straight line (axis of cylinder). Indicating the corresponding datum alone in a tolerance frame can lock up to four degrees of freedom of the tolerance zone, but will leave at least two degrees of freedom (a translation and a rotation) unlocked.

EXAMPLE 2 For a nominal conical surface, used to establish a single datum, the nominal surface is invariant only in one direction (1 rotation), so it belongs to the “revolute” invariance class and has an invariance degree of 1 (see Table B.1). The situation features used to establish the datum from this feature are a straight line (the axis of the cone) and a point (one point on the axis). Indicating the corresponding datum alone in a tolerance frame can lock up to five degrees of freedom of the tolerance zone, but will leave at least one degree of freedom (a rotation) unlocked.

EXAMPLE 3 For two nominally cylindrical, non-coaxial surfaces with parallel axes, used to establish a common datum, the nominal collection surface is invariant only in one direction (one translation), so it belongs to the “prismatic” invariance class and has an invariance degree of 1 (see Table B.1). The situation features used together to establish the datum from these features are a straight line (the median line of the two axes of the associated cylinders) and a plane (the plane containing the two axis of the associated cylinders). Indicating the corresponding datum alone in a tolerance frame can lock up to five degrees of freedom of the tolerance zone, but will leave at least one degree of freedom (a translation) unlocked.

Annex C (informative)

Examples

Content

C.1	Examples of single datums	50
C.1.1	Plane	50
C.1.2	Cylinder	51
C.1.3	Cone	52
C.1.4	Sphere.....	53
C.1.5	Particular situation feature	54
C.1.6	Obvious situation feature	55
C.1.7	Only one situation feature needed	56
C.1.8	Complex surface.....	57
C.1.9	Intersecting planes	58
C.1.10	Two parallel opposite planes (defined as a feature of size).....	59
C.1.11	Three datum targets on a plane	60
C.2	Examples of common datums	61
C.2.1	Two coplanar planes	61
C.2.2	Two coaxial cylinders	62
C.2.3	Plane and cylinder perpendicular to each other	63
C.2.4	Two parallel cylinders.....	64
C.2.5	Pattern of five cylinders.....	65
C.2.6	Two parallel planes	66
C.3	Examples of datum systems	67
C.3.1	Three perpendicular planes	67
C.3.2	Perpendicular plane and cylinder.....	69

In the following examples, the default association criterion used is defined in Annex A.

C.1 Examples of single datums

C.1.1 Plane

Figure C.1 illustrates the drawing indication of the design intent.

Design intent (writing input)

Use the integral, nominally planar surface, which is not a feature of size, to establish a datum. The datum is used alone to orient and/or locate the tolerance zone relative to its planar situation feature.

Drawing indication (reading input or writing output)



Figure C.1 — Plane — Input for reading (drawing indication) and for writing (design intent)

Explanation:

- The real integral surface is obtained after partition/extraction [see Figure C.2 a)].
- According to 6.3.2, the single datum is characterized by the situation feature of the plane associated with the real integral feature without external constraints [see Figure C.2 b)]. The invariance class of the nominal surface is planar and the situation feature is a plane [see Figure C.2 c)].

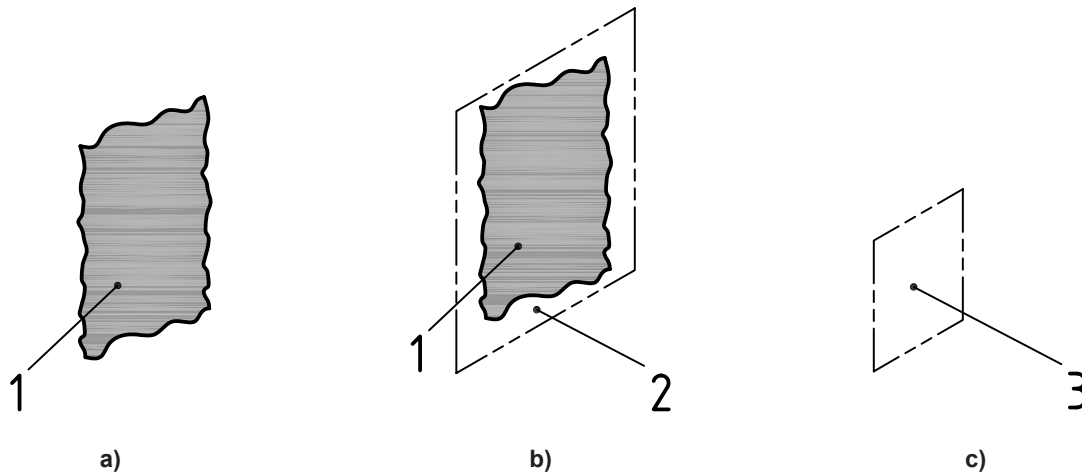

Key

- 1 datum feature: real integral feature
- 2 associated feature constraint: tangent outside of material
- 3 single datum – situation feature of the associated feature: plane

NOTE Illustrations are given in 2D view.

Figure C.2 — Establishing a single datum from a planar surface

C.1.2 Cylinder

Figure C.3 illustrates the drawing indication of the design intent.

Design intent (writing input)

Use the integral, nominally cylindrical surface, which is a feature of size, to establish a datum by considering its size variable. The datum is used alone to orient and/or locate the tolerance zone relative to its situation feature, which is the axis of the associated cylinder.

Drawing indication (reading input or writing input)

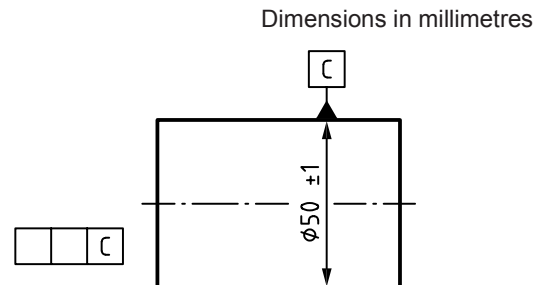
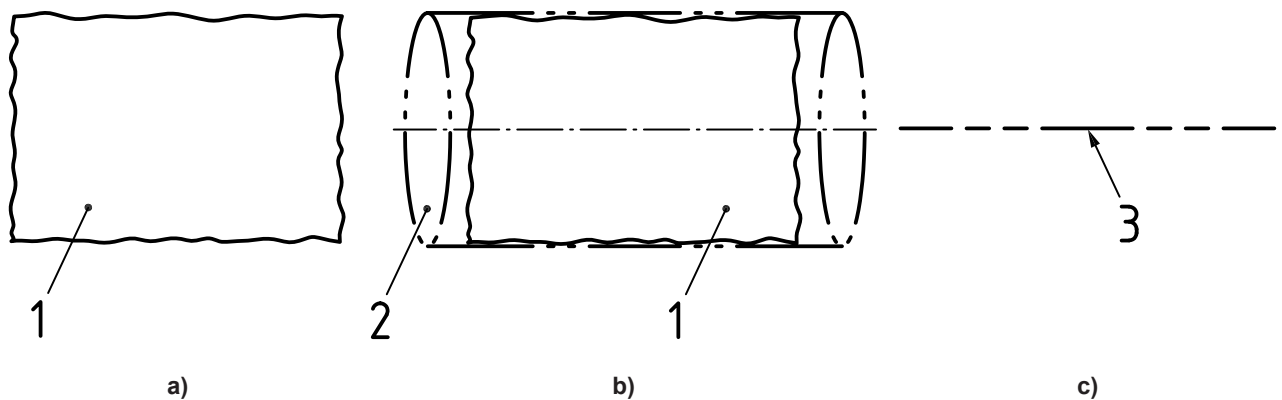

Figure C.3 — Cylinder — Input for reading (drawing indication) and for writing (design intent)

Explanation:

- The real integral surface is obtained after partition/extraction [see Figure C.4 a)].
- According to 6.3.2, the single datum is characterized by the situation feature of the cylinder associated with the real integral feature without external constraints [see Figure C.4 b)]. The invariance class of the nominal surface is cylindrical and the situation feature is the axis of the cylinder [see Figure C.4 c)].



Key

- 1 datum feature: real integral feature
- 2 associated feature with variable diameter
- 3 single datum – situation feature of the associated feature: straight line (axis of the cylinder)

Figure C.4 — Establishing a single datum from a cylindrical surface

C.1.3 Cone

Figure C.5 illustrates the drawing indication of the design intent.

Design intent (writing input)

Use the integral, nominally conical surface, which is a feature of size, to establish a datum by considering its size fixed. The datum is used alone to orient and/or locate the tolerance zone relative to its situation features, which are the axis of the associated cone and a point along this axis.

Drawing indication (reading input or writing input)

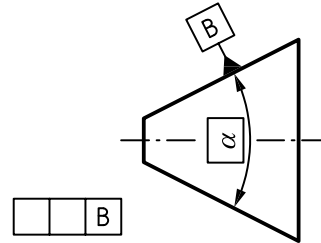
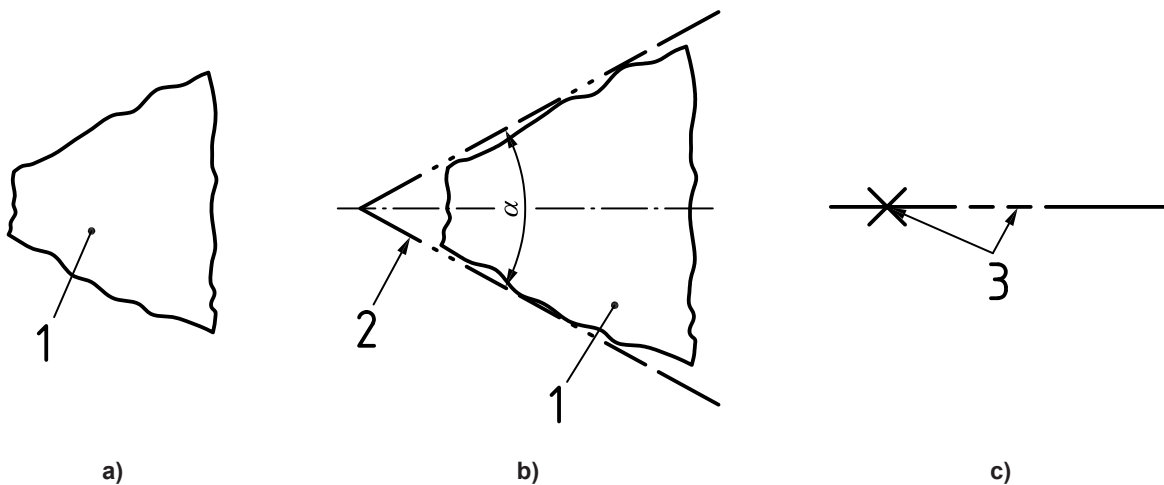

Figure C.5 — Cone — Input for reading (drawing indication) and for writing (design intent)

Explanation:

- The real integral surface is obtained after partition/extraction [see Figure C.6 a)].
- According to 6.3.2, the single datum is characterized by the situation features of the cone associated with the real integral feature without external constraints [see Figure C.6 b)]. The invariance class of the nominal surface is revolute and the situation features are the axis of the cone and a point along this axis [see Figure C.6 c)].



Key

- 1 datum feature: real integral feature
- 2 associated feature with fixed intrinsic characteristic constraint (angle α)
- 3 single datum – situation features of the associated feature: straight line (axis of the cone) and point (point on the axis)

Figure C.6 — Establishing a single datum from a conical surface

C.1.4 Sphere

Figure C.7 illustrates the drawing indication of the design intent.

Design intent (writing input)

Use the integral, nominally spherical surface, which is a feature of size, to establish a datum by considering its size variable. The datum is used alone to orient and/or locate the tolerance zone relative to its situation feature, which is the centre of the associated sphere.

Drawing indication (reading input or writing input)

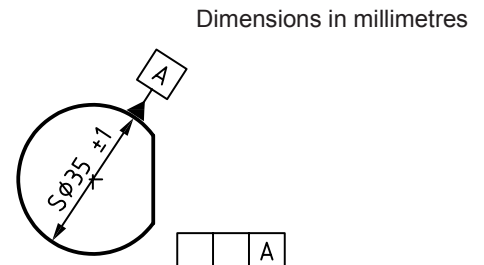
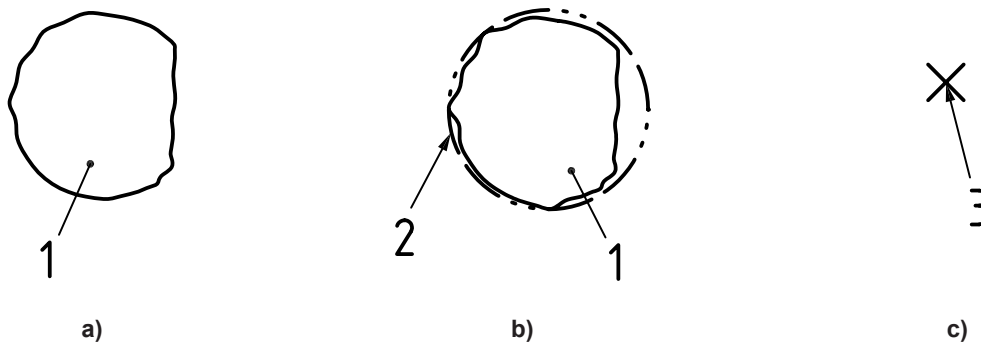

Figure C.7 — Sphere — Input for reading (drawing indication) and for writing (design intent)

Explanation:

- The real integral surface is obtained after partition/extraction [see Figure C.8 a)].
- According to 6.3.2, the single datum is characterized by the situation features of the sphere associated with the real integral feature without external constraints [see Figure C.8 b)]. The invariance class of the nominal surface is spherical and the situation feature is the centre of the sphere [see Figure C.8 c)].



Key

- 1 datum feature: real integral feature
- 2 associated feature with variable diameter
- 3 single datum — situation feature of the associated feature: point (centre of the sphere)

NOTE The fourth contacting point is not visible in 2D view

Figure C.8 — Establishing a single datum from a spherical surface

C.1.5 Particular situation feature

Figure C.9 illustrates the drawing indication of the design intent.

Design intent (writing input)

Use the integral, nominally conical surface, which is a feature of size, to establish a datum by considering its size fixed. The datum is used alone to orient and locate the tolerance zone relative to its situation features, which are the axis of the associated cone and a particular point along the axis, defined by the location where the section diameter is specified.

**Drawing indication
 (reading input or writing input)**

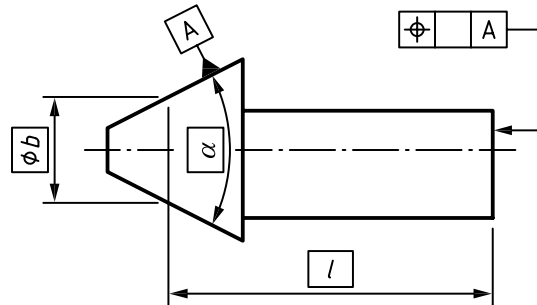

NOTE This particular point is defined by the intersection between a plane and the axis of the cone. This plane is perpendicular to the axis of the cone and its location defined by the TED ϕb that defines the diameter of a circle. This circle is the intersection between the associated cone and the plane.

Figure C.9 — Particular situation feature — Input for reading (drawing indication) and for writing (design intent)

Explanation:

- The real integral surface is obtained after partition/extraction [see Figure C.10 a)].
- According to 6.3.2, the single datum is characterized by the situation features of the cone associated with the real integral feature without external constraints [see Figure C.10 b)]. The invariance class of the nominal surface is revolute and the situation features are the axis of the cone and a particular point along this axis [see Figure C.10 c)].

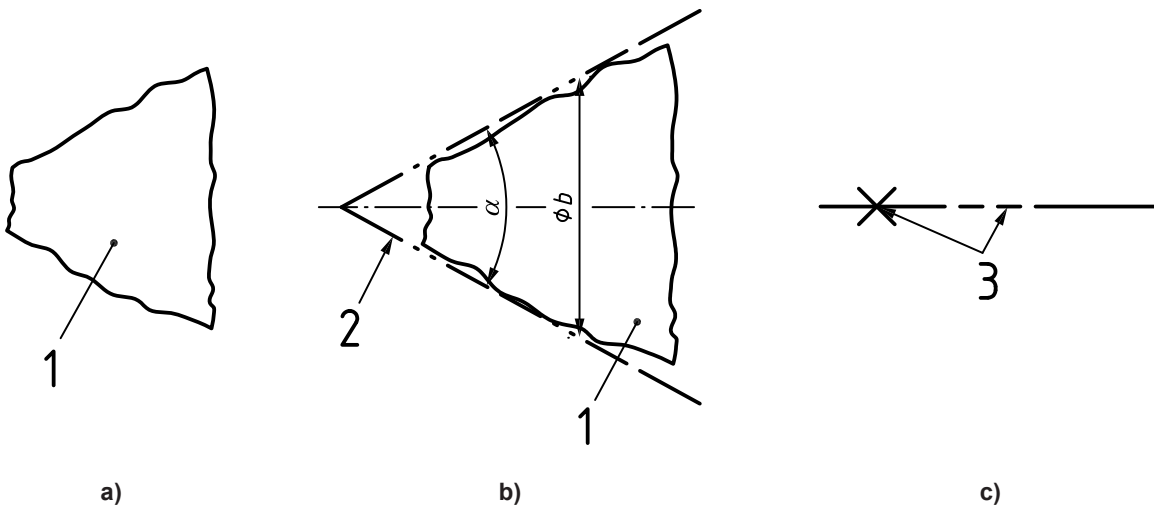

Key

- 1 datum feature: real integral feature
- 2 associated feature with fixed intrinsic characteristic constraint (angle α)
- 3 single datum – situation feature of the associated feature: straight line (axis of the cone) and point (point on the axis of the cone where the section diameter is ϕb)

Figure C.10 — Establishing a single datum from a conical surface, where the specific relationship between the tolerated feature and the datum is given

C.1.6 Obvious situation feature

Figure C.11 illustrates the drawing indication of the design intent.

Design intent (writing input)

Use the integral, nominally conical surface, which is a feature of size, to establish a datum by considering its size fixed. The datum is used alone to orient and locate the tolerance zone relative to an axis. This axis is the situation feature of the associated cone.

Drawing indication (reading input or writing input)

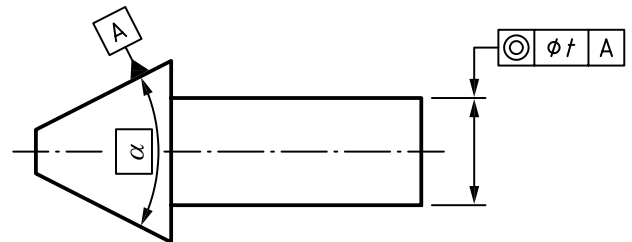
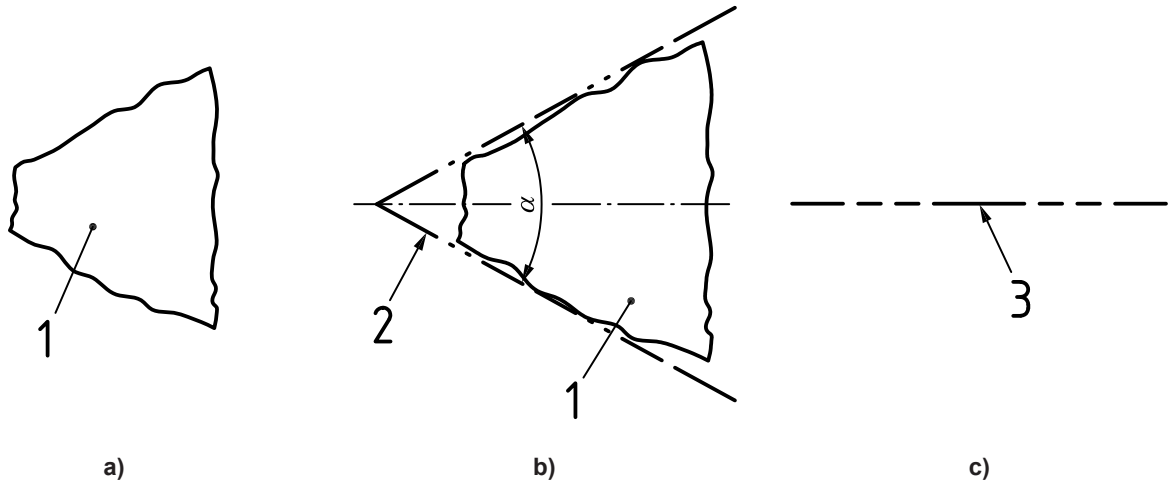

Figure C.11 — Obvious situation feature — Input for reading (drawing indication) and for writing (design intent)

Explanation:

- The real integral surface is obtained after partition/extraction [see Figure C.12 a)].
- According to 6.3.2, the single datum is characterized by the situation feature of the cone associated with the real integral feature without external constraints [see Figure C.12 b)]. The invariance class of the nominal surface is revolute and the situation features are the axis of the cone and a particular point along this axis. In this case, the point is not involved in the location of the tolerance zone [see Figure C.12 c)].



Key

- 1 datum feature: real integral feature
- 2 associated feature with fixed intrinsic characteristic constraint (angle α)
- 3 single datum – only the straight line of the situation feature of the associated feature: straight line

Figure C.12 — Establishing a single datum where the situation feature is obvious

C.1.7 Only one situation feature needed

Figure C.13 illustrates the drawing indication of the design intent.

Design intent (writing input)

Use the integral, nominally conical surface, which is a feature of size, to establish a datum by considering its size fixed. The datum is used alone to orient and locate the tolerance zone relative to one of the situation features of the associated cone (the situation feature is a straight line: the axis of the associated cone).

Drawing indication (reading input or writing input)

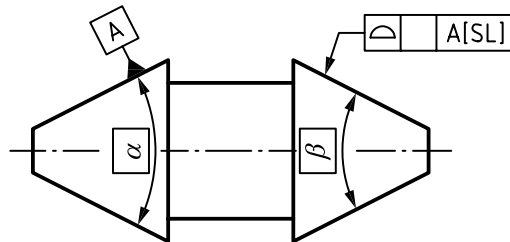
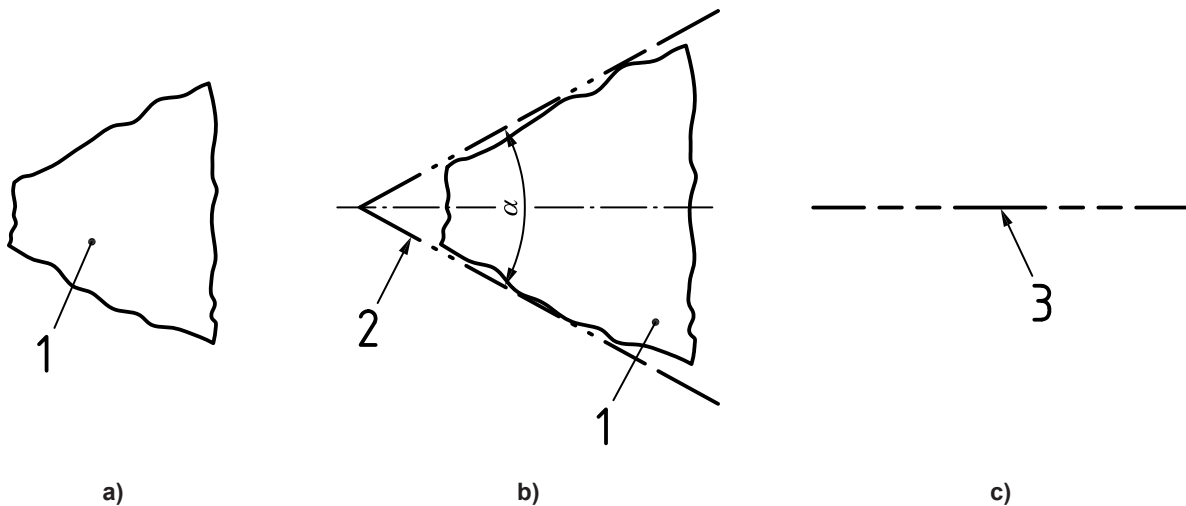

Figure C.13 — Only one situation feature needed — Input for reading (drawing indication) and for writing (design intent)

Explanation:

- The real integral surface is obtained after partition/extraction [see Figure C.14 a].
- According to 6.3.2, the single datum is characterized by the situation features of the cone associated with the real integral feature without external constraints [see Figure C.14 b)]. The invariance class of the nominal surface is revolutes and the situation features are the axis and the cone and a particular point along this axis. Because a complementary indication [SL] is given, only the axis of the cone is considered [see Figure C.14 c)].



Key

- 1 datum feature: real integral feature
- 2 associated feature with fixed intrinsic characteristic constraint (angle α)
- 3 single datum – only the straight line of the situation features of the associated feature (straight line and point)

Figure C.14 — Establishing a single datum where only one situation feature is needed

C.1.8 Complex surface

Figure C.15 illustrates the drawing indication of the design intent.

Design intent (writing input)

Use the integral, nominally complex surface, which is not a feature of size, to establish a datum. The datum is used alone to orient and/or locate the tolerance zone relative to the situation features of the associated surface which are a plane, a straight line and a point.

Drawing indication (reading input or writing input)

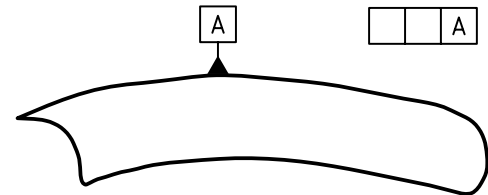
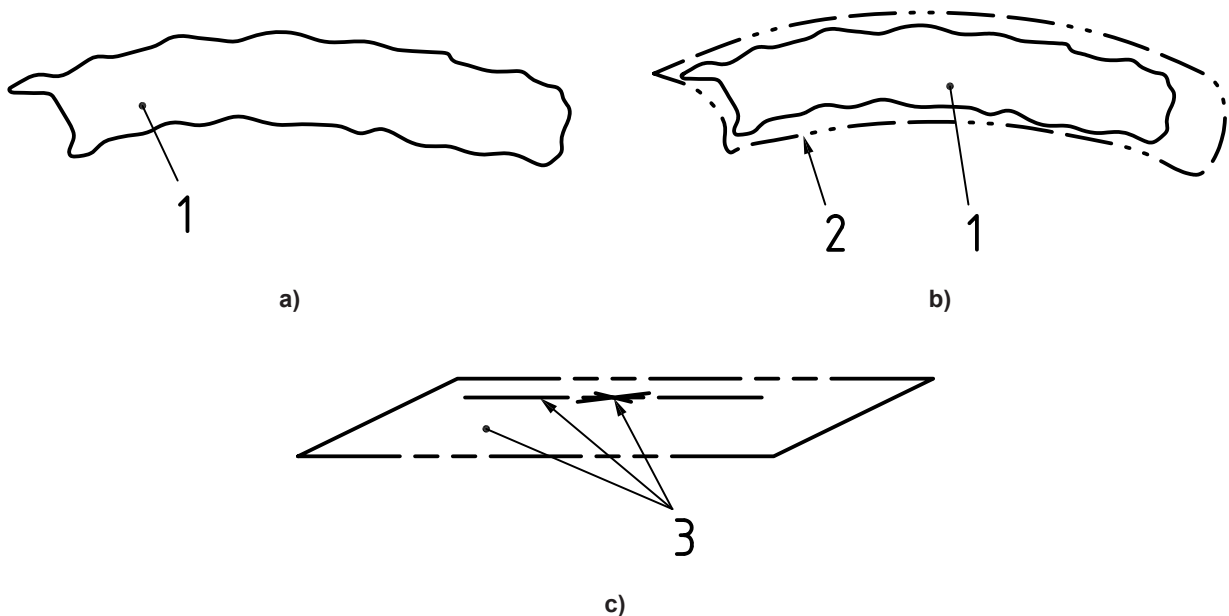

Figure C.15 — Complex surface — Input for reading (drawing indication) and for writing (design intent)

Explanation:

- The real integral surface is obtained after partition/extraction [see Figure C.16 a)].
- According to 6.3.2, the single datum is characterized by the situation features of the complex surface associated with the real integral feature without external constraints [see Figure C.16 b)]. The invariance class of the nominal surface is complex and the situation features are a plane, a straight line and a point [see Figure C.16 c)].



Key

- 1 datum feature: real integral feature
- 2 associated feature
- 3 single datum – situation feature of the associated feature: plane, straight line and point

Figure C.16 — Establishing a single datum from a complex surface

C.1.9 Intersecting planes

Figure C.17 illustrates the drawing indication of the design intent.

Design intent (writing input)

Use the real integral surface resulting from the collection of two intersecting nominally planar surfaces, which constitutes a feature of size (a wedge), to establish a datum by considering its size fixed. The datum is used alone to orient and/or locate the tolerance zone relative to the situation feature of the associated feature of size. The situation features are a plane (the bisector plane) and a straight line (intersection of the two associated planes, with a fixed angle between them).

Drawing indication (reading input or writing input)

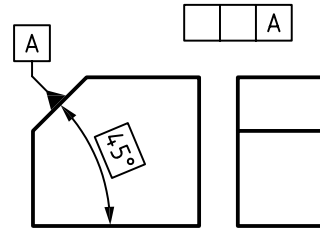
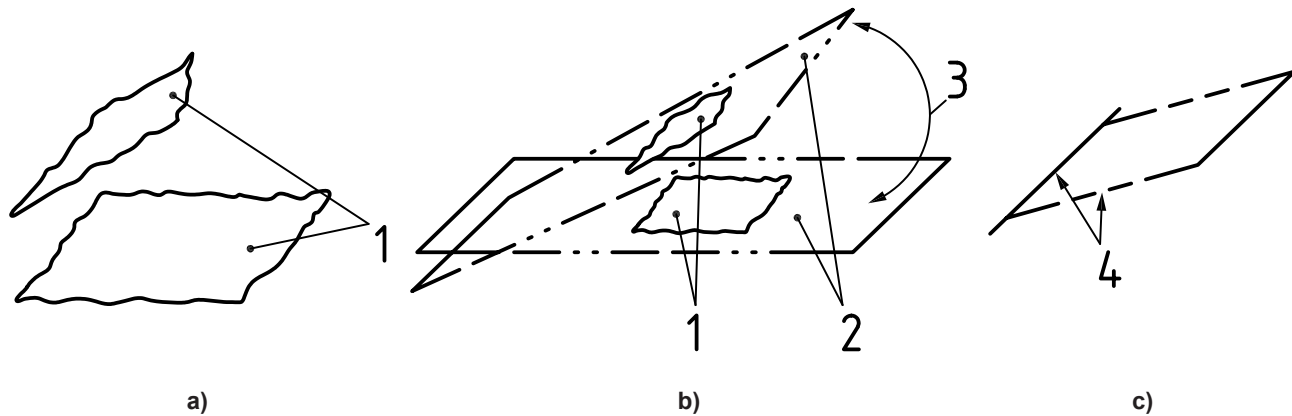

Figure C.17 — Intersecting planes — Input for reading (drawing indication) and for writing (design intent)

Explanation:

- The two real integral surfaces are obtained after partition/extraction and collection and constitute a feature of size with fixed angle [see Figure C.18 a)].
- According to 6.3.2, the single datum consists of the situation features of the collection of the two intersecting planes associated with the real integral features used for establishing the single datum. The association is global and an internal orientation constraint (fixed angle of 45°) exists [see Figure C.18 b)]. The invariance class of the collection of nominally planar surfaces is prismatic and the situation features are a plane (the bisector plane) and a straight line (the intersecting straight line) [see Figure C.18 c)].



Key

- 1 datum feature: real integral feature
- 2 associated features with orientation constraint (fixed angle 45°)
- 3 internal orientation constraint (angularity)
- 4 single datum – situation features of the associated feature: plane and straight line

Figure C.18 — Establishing a single datum from intersecting planes

C.1.10 Two parallel opposite planes (defined as a feature of size)

Figure C.19 illustrates the drawing indication of the design intent.

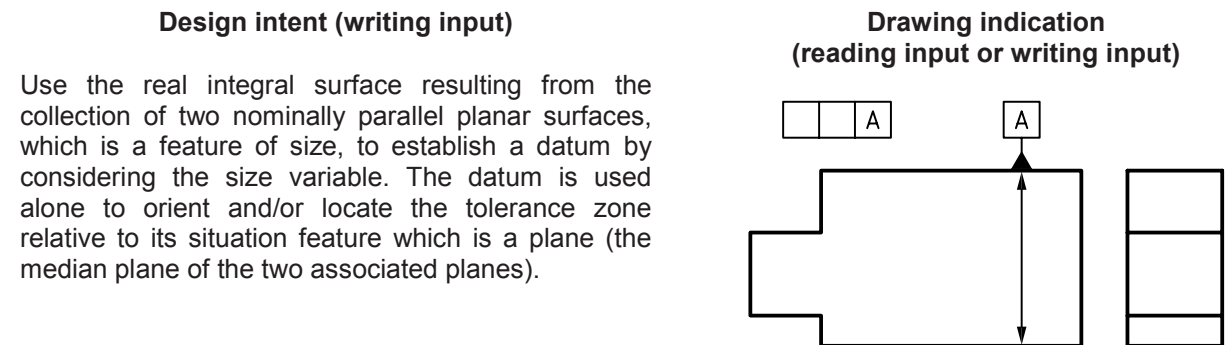
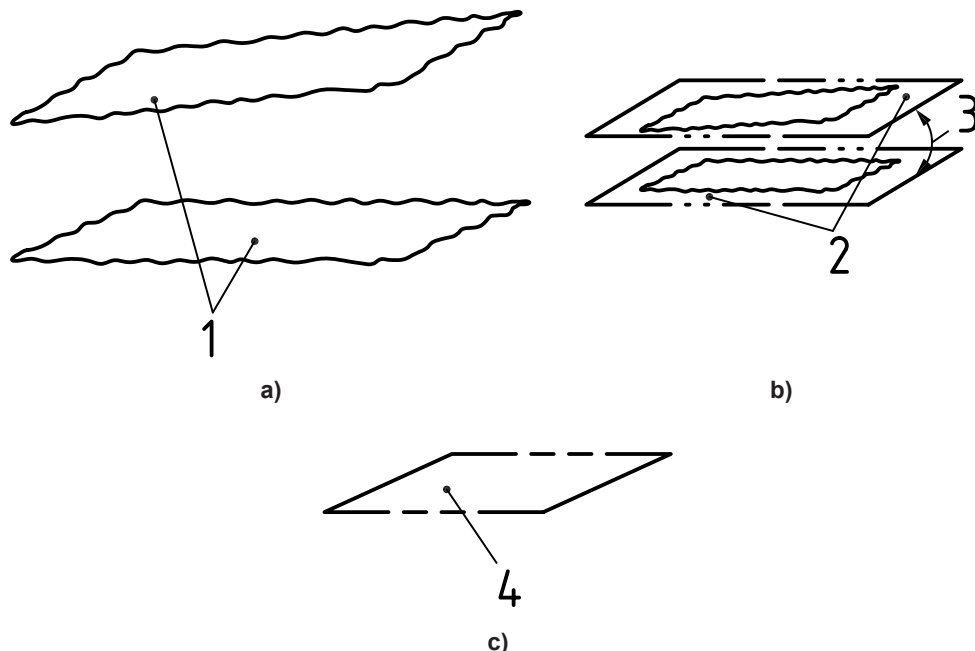

Figure C.19 — Two parallel planes — Input for reading (drawing indication) and for writing (design intent)

Explanation:

- The two real integral surfaces are obtained after partition/extraction and collection and constitute a feature of size with variable size [see Figure C.20 a)].
- According to 6.3.2, the single datum is characterized by the situation feature of the collection of two parallel planes associated with the real integral features used for establishing the single datum. The association is global and an internal orientation constraint of parallelism exists (the distance between the two planes is variable) [see Figure C.20 b)]. The invariance class of the collection of nominal surfaces is planar and the situation feature is a plane (the median plane of the two associated planes) [see Figure C.20 c)].



Key

- 1 datum feature: real integral feature
- 2 associated features with variable distance
- 3 internal orientation constraint only (parallelism) (the size is variable for association)
- 4 single datum – situation feature of the collection surface: plane

Figure C.20 — Establishing a single datum from a feature of size - two parallel opposite planes

C.1.11 Three datum targets on a plane

Figure C.21 illustrates the drawing indication of the design intent.

Design intent (writing input)

Use three portions of a nominally planar surface, which is not a feature of size, to establish a datum. The datum is used alone to orient and/or locate the tolerance zone relative to the situation feature of the associated plane. This plane is established from three portions belonging to the same surface.

**Drawing indication
 (reading input or writing input)**

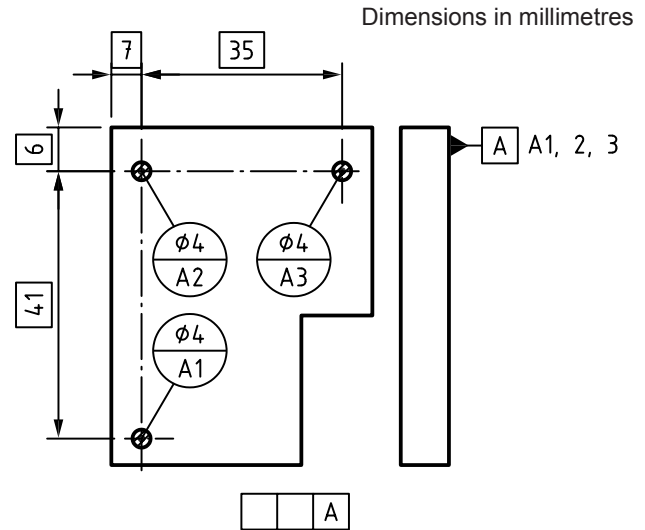
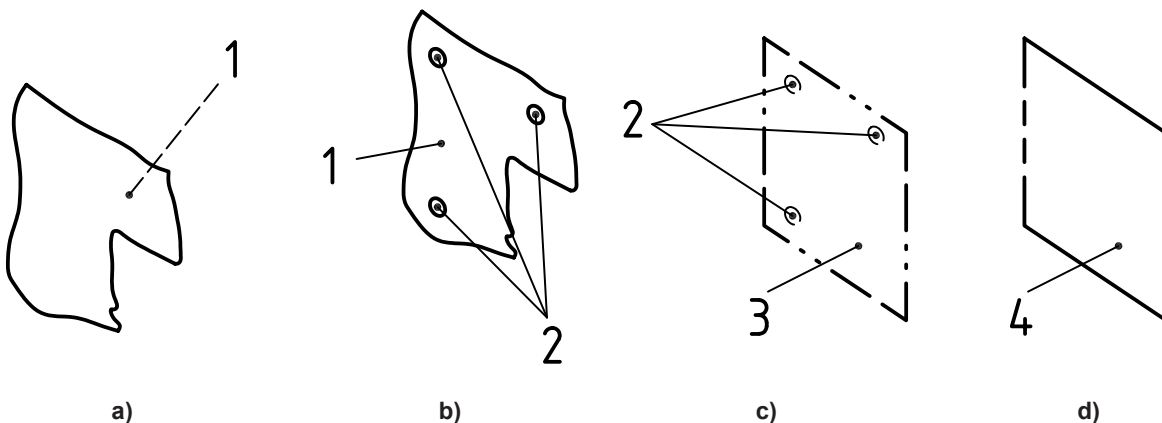

Figure C.21 — Three datum targets on a plane — Input for reading (drawing indication) and for writing (design intent)

Explanation:

- The datum target areas are obtained after partition/extraction by using the TEDs which define the location and the dimension of the areas from the datum feature [see Figures C.22 a) and C.22 b)].
- According to 6.3.2, the single datum is characterized by the situation feature of the plane associated with the real integral feature without external constraints [see Figure C.22 c)]. The invariance class of the nominal surface is planar and the situation feature is a plane [see Figure C.22 d)].



Key

- 1 datum feature: real integral feature
- 2 datum targets taken on the datum feature
- 3 associated feature to the three datum targets
- 4 single datum – situation feature of the collection surface: plane

Figure C.22 — Establishing a single datum from three datum targets on a planar surface

C.2 Examples of common datums

C.2.1 Two coplanar planes

Figure C.23 illustrates the drawing indication of the design intent.

Design intent (writing input)

Use two integral, nominally planar surfaces constrained to be coplanar, which are not features of size, simultaneously to establish a datum. The datum is used to orient and/or locate the tolerance zone relative to a plane. This plane is the situation feature of the collection of the two associated planes.

Drawing indication (reading input or writing input)

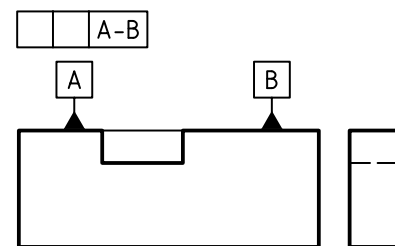
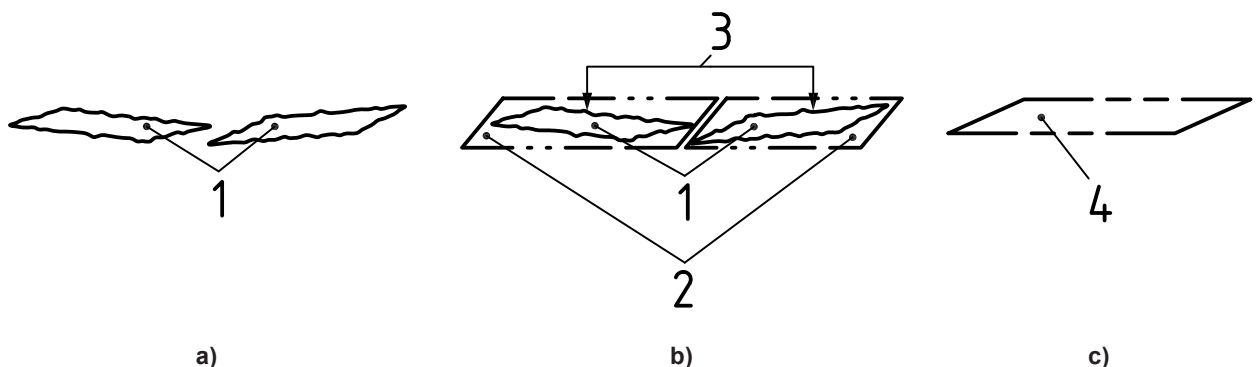

Figure C.23 — Two coplanar planes — Input for reading (drawing indication) and for writing (design intent)

Explanation:

- The real integral surfaces are obtained after partition/extraction and collection [see Figure C.24 a)].
- According to 6.3.3, the common datum is characterized by the situation feature of the collection of two coplanar planes associated with the real integral features used for establishing the common datum. The association is global and with internal constraints: coplanar (i.e. distance zero and parallel) [see Figure C.24 b)]. The invariance class of the collection of nominal surfaces is planar and the situation feature is a plane [see Figure C.24 c)].



Key

- 1 datum features: real integral features
- 2 associated features (two associated planes)
- 3 orientation and location constraint (coplanarity) between associated features
- 4 single datum – situation feature of the collection surface: plane

Figure C.24 — Establishing a common datum from two coplanar planes

C.2.2 Two coaxial cylinders

Figure C.25 illustrates the drawing indication of the design intent.

Design intent (writing input)

Use two integral, nominally cylindrical and coaxial, surfaces, which are features of size, simultaneously to establish a datum by considering their sizes variable and the orientation constraint (parallelism) and location constraint (coaxiality). The datum is used to orient and/or locate the tolerance zone relative to an axis. This axis is the situation feature of the collection of the two associated cylinders.

**Drawing indication
 (reading input or writing input)**

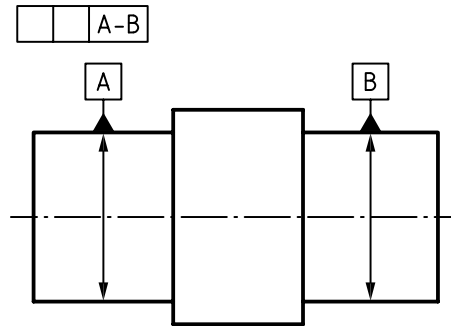
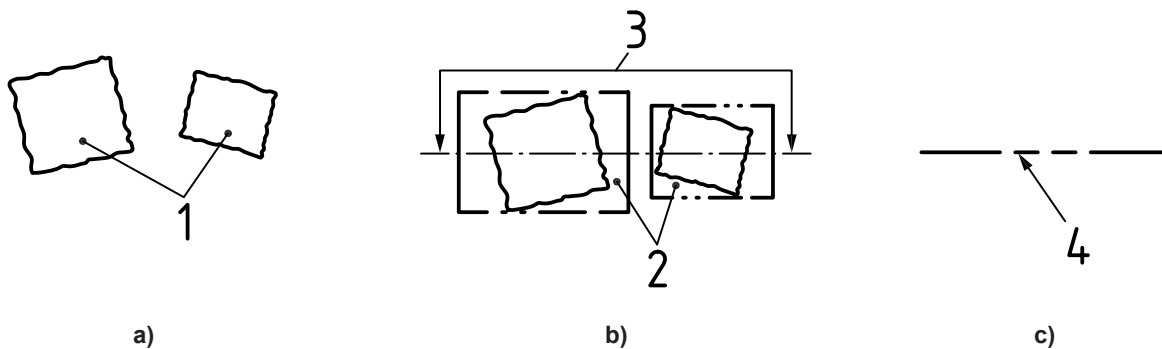

Figure C.25 — Two coaxial cylinders — Input for reading (drawing indication) and for writing (design intent)

Explanation:

- The real integral surfaces are obtained after partition/extraction and collection [see Figure C.26 a)].
- According to 6.3.3, the common datum is characterized by the situation feature of the collection of two coaxial cylinders associated with the real integral features used for establishing the common datum. The association is global and with internal constraints: distance zero and parallel (coaxial) [see Figure C.26 b)]. The invariance class of the collection of nominal surfaces is cylindrical and the situation feature is the common axis of the two cylinders [see Figure C.26 c)].



Key

- 1 datum feature: real integral feature
- 2 associated features with variable diameters
- 3 orientation constraint (parallelism) and location constraint (coaxiality)
- 4 single datum – situation feature of the associated feature: straight line (common axis)

Figure C.26 — Establishing a common datum from two coaxial cylinders

C.2.3 Plane and cylinder perpendicular to each other

Figure C.27 illustrates the drawing indication of the design intent.

Design intent (writing input)

Use two integral surfaces, which are a nominally planar surface (which is not a feature of size) and a cylindrical surface (which is a feature of size) respectively, and which are nominally perpendicular to each other, simultaneously to establish a datum by considering the size of the cylinder variable and the orientation constraint (perpendicularity) between the axis of the associated cylinder and the associated plane (without defined order). The datum is used to orient and/or locate the tolerance zone relative to a straight line and one of its points. The axis and the point are the situation features of the collection of the two associated features.

Drawing indication (reading input or writing input)

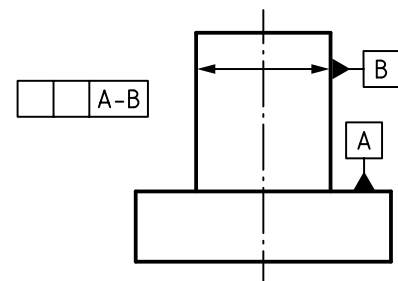
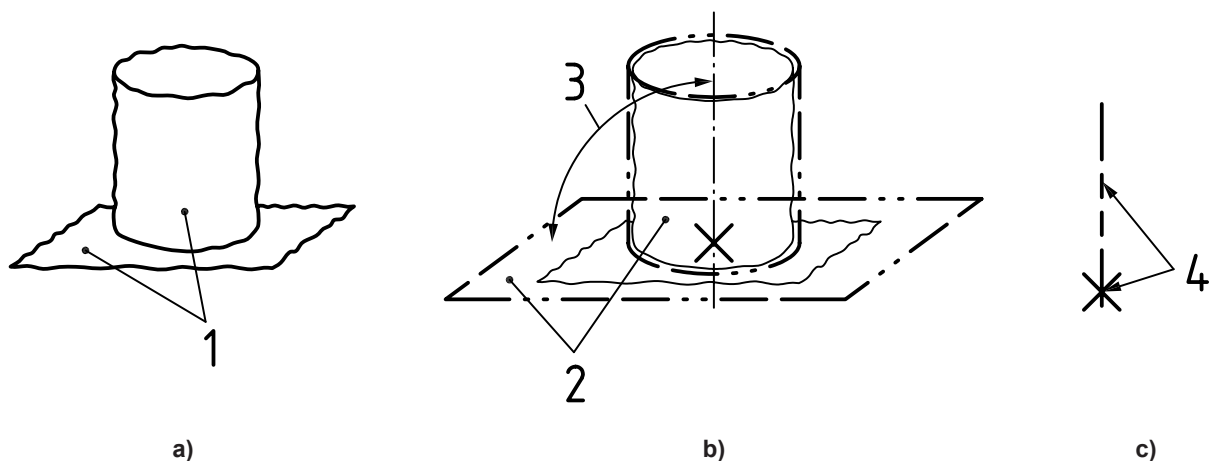

Figure C.27 — Plane and perpendicular cylinder — Input for reading (drawing indication) and for writing (design intent)

Explanation:

- The real integral surfaces are obtained after partition/extraction and collection [see Figure C.28 a)].
- According to 6.3.3, the common datum is characterized by the situation features of the collection of a plane and a cylinder perpendicular to each other associated with the real integral features used for establishing the common datum. The association is global and with internal constraints: an angle of 90° between the axis and the plane [see Figure C.28 b)]. The invariance class of the collection of nominal surfaces is revolute and the situation features are the axis of the cylinder and the point resulting from the intersection of the plane and the axis [see Figure C.28 c)].



Key

- 1 datum features: real integral features
- 2 associated features (an associated cylinder with variable diameter and an associated plane)
- 3 orientation constraint (perpendicularity)
- 4 single datum – situation feature of the associated feature: straight line and one point

Figure C.28 — Establishing a common datum from a plane and a perpendicular cylinder

C.2.4 Two parallel cylinders

Figure C.29 illustrates the drawing indication of the design intent.

Design intent (writing input)

Use two integral, nominally cylindrical and parallel surfaces, which are features of size, simultaneously to establish a datum by considering the size of the cylinders variable and the orientation constraint (parallelism) and location constraint (l mm) between the two axes. The datum is used to orient and/or locate the tolerance zone relative to a plane and a straight line in the plane. The plane and the straight line are the situation features of the collection of the two associated features.

**Drawing indication
 (reading input and writing input)**

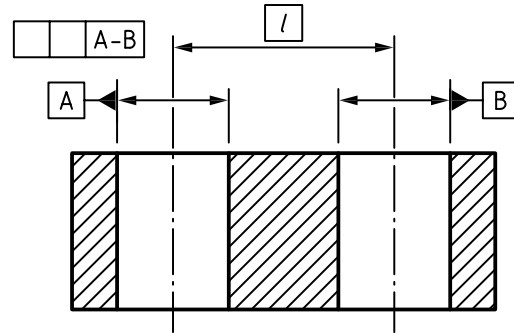
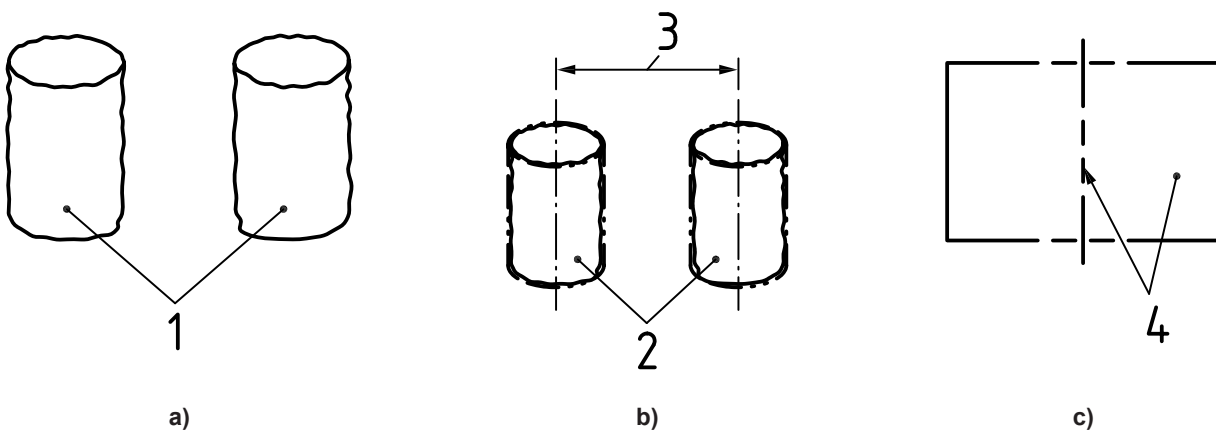

Figure C.29 — Two parallel cylinders — Input for reading (drawing indication) and for writing (design intent)

Explanation:

- The real integral surfaces are obtained after partition/extraction and collection [see Figure C.30 a)].
- According to 6.3.3, the common datum is characterized by the situation features of the collection of two parallel cylinders associated with the real integral features used for establishing the common datum. The association is global and with internal constraints: distance between the two axes and parallelism [see Figure C.30 b)]. The invariance class of the collection of nominal surfaces is prismatic and the situation features are the plane containing the two axes and the median straight line of the axes of the two associated cylinders [see Figure C.30 c)].



Key

- 1 datum features: real integral features
- 2 associated features with variable diameters
- 3 orientation constraint (parallelism) and location constraint (l distance)
- 4 common datum – situation feature of the collection surface: plane and straight line

Figure C.30 — Establishing a common datum from two parallel cylinders

C.2.5 Pattern of five cylinders

Figure C.31 illustrates the drawing indication of the design intent.

Design intent (writing input)

Use five integral, nominally identical and cylindrical surfaces, which are features of size, with parallel axes together simultaneously to establish a datum by considering the size of cylinders variable and the orientation constraints (parallelism) and location constraints (d mm and $4 \times 72^\circ$). The datum is used to orient and/or locate the tolerance zone relative to a plane and a straight line in the plane. The plane and the straight line are the situation features of the collection of the five associated features.

Drawing indication (reading input or writing input)

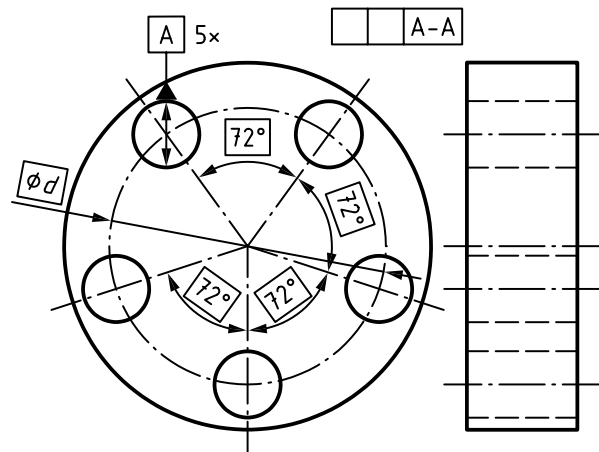
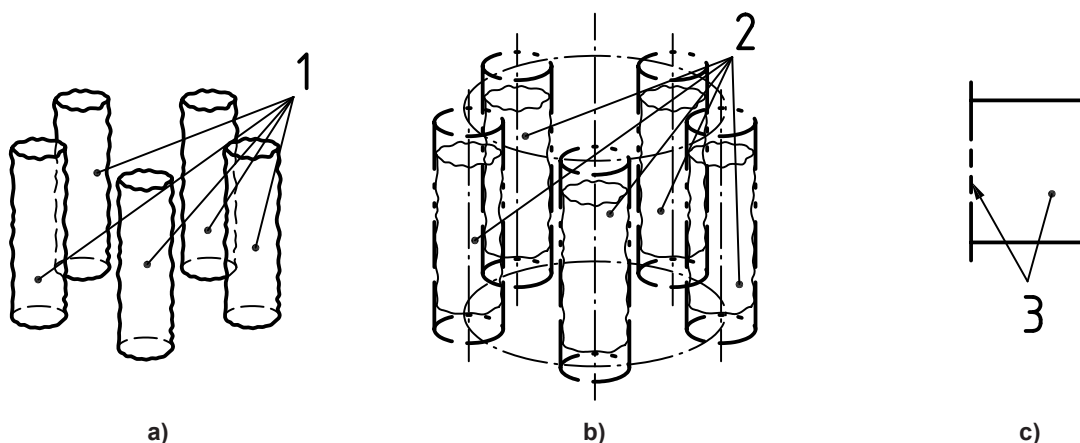

Figure C.31 — Pattern of five cylinders — Input for reading (drawing indication) and for writing (design intent)

Explanation:

- The real integral surfaces are obtained after partition/extraction and collection [see Figure C.32 a)].
- According to 6.3.3, the common datum is characterized by the situation features of the collection of five parallel cylinders associated with the real integral features used for establishing the common datum. The association is simultaneous and with internal constraints: parallelism, distance and angle between the five axes [see Figure C.32 b)]. The invariance class of the collection of nominal surfaces is prismatic and the situation features are the median straight line of the axes of the five associated cylinders and a plane containing one axis and this median straight line [see Figure C.32 c)].

NOTE The actual planar situation feature is specified by the tolerance frame and by TED(s), if applicable.



Key

- 1 datum features: real integral features
- 2 associated features: with variable diameters, orientation constraint (parallelism) and location constraint (given by the TEDs and angles of 72°)
- 3 common datum – situation features of the collection surface: plane and straight line

Figure C.32 — Establishing a common datum from a pattern of five cylinders

C.2.6 Two parallel planes

Figure C.33 illustrates the drawing indication of the design intent.

Design intent (writing input)

Use two integral, nominally planar and parallel surfaces, which are not features of size, simultaneously to establish a datum with a constraint of distance between the two planes. The datum is used to orient and/or locate the tolerance zone relative to a plane. This plane is the situation feature of the collection of the two associated planes which are constrained to be parallel and separated by a value indicated as a TED.

**Drawing indication
 (reading input or writing input)**

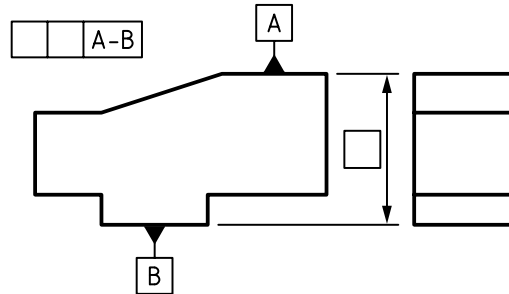
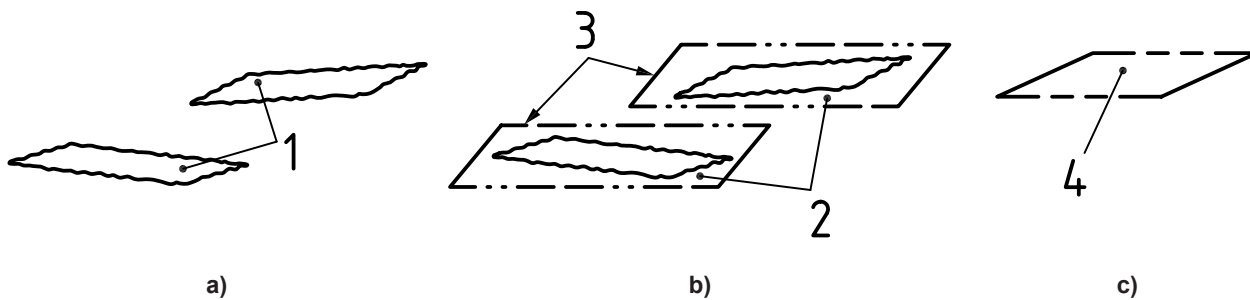

Figure C.33 — Two parallel planes — Input for reading (drawing indication) and for writing (design intent)

Explanation:

- The two real integral surfaces, which do not constitute a feature of size, are obtained after partition/extraction and collection [see Figure C.34 a)].
- According to 6.3.3, the common datum is characterized by the situation features of the collection of two parallel planes associated with the real integral features used for establishing the common datum. The association is global and with internal constraints: fixed distance defined by a TED and parallelism [see Figure C.34 b)]. The invariance class of the collection of nominal surfaces is planar and the situation feature is a plane [see Figure C.34 c)].



Key

- 1 datum features: two real integral features
- 2 associated features (two associated planes)
- 3 orientation constraint (parallelism) and location constraint (distance defined by a TED)
- 4 common datum – situation feature of the collection surface: plane

Figure C.34 — Establishing a common datum from two parallel planes

C.3 Examples of datum systems

C.3.1 Three perpendicular planes

Figure C.35 illustrates the drawing indication of the design intent.

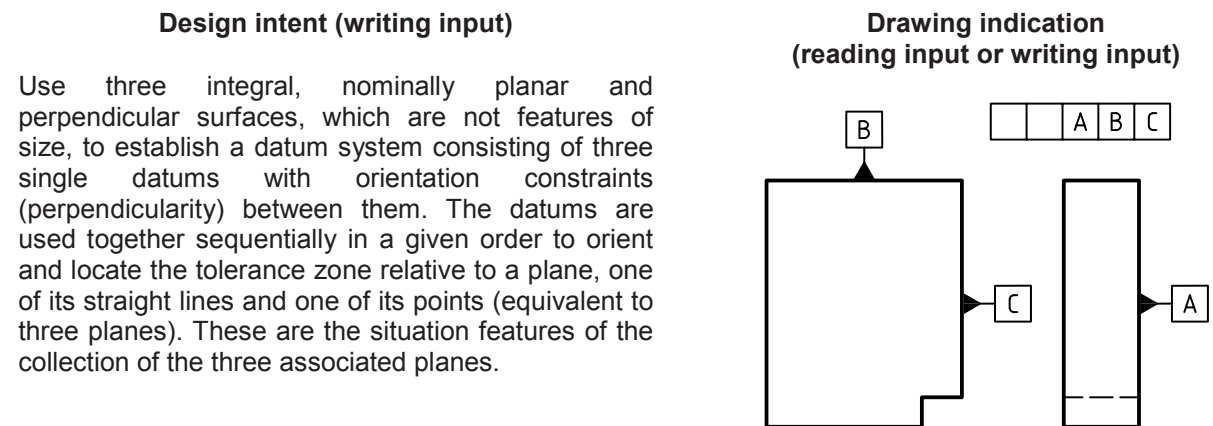

Figure C.35 — Three perpendicular planes — Input for reading (drawing indication) and for writing (design intent)

Explanation:

- The real integral surfaces are obtained after partition/extraction and collection (see Figure C.36).

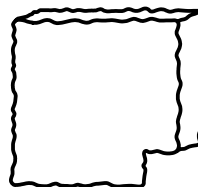
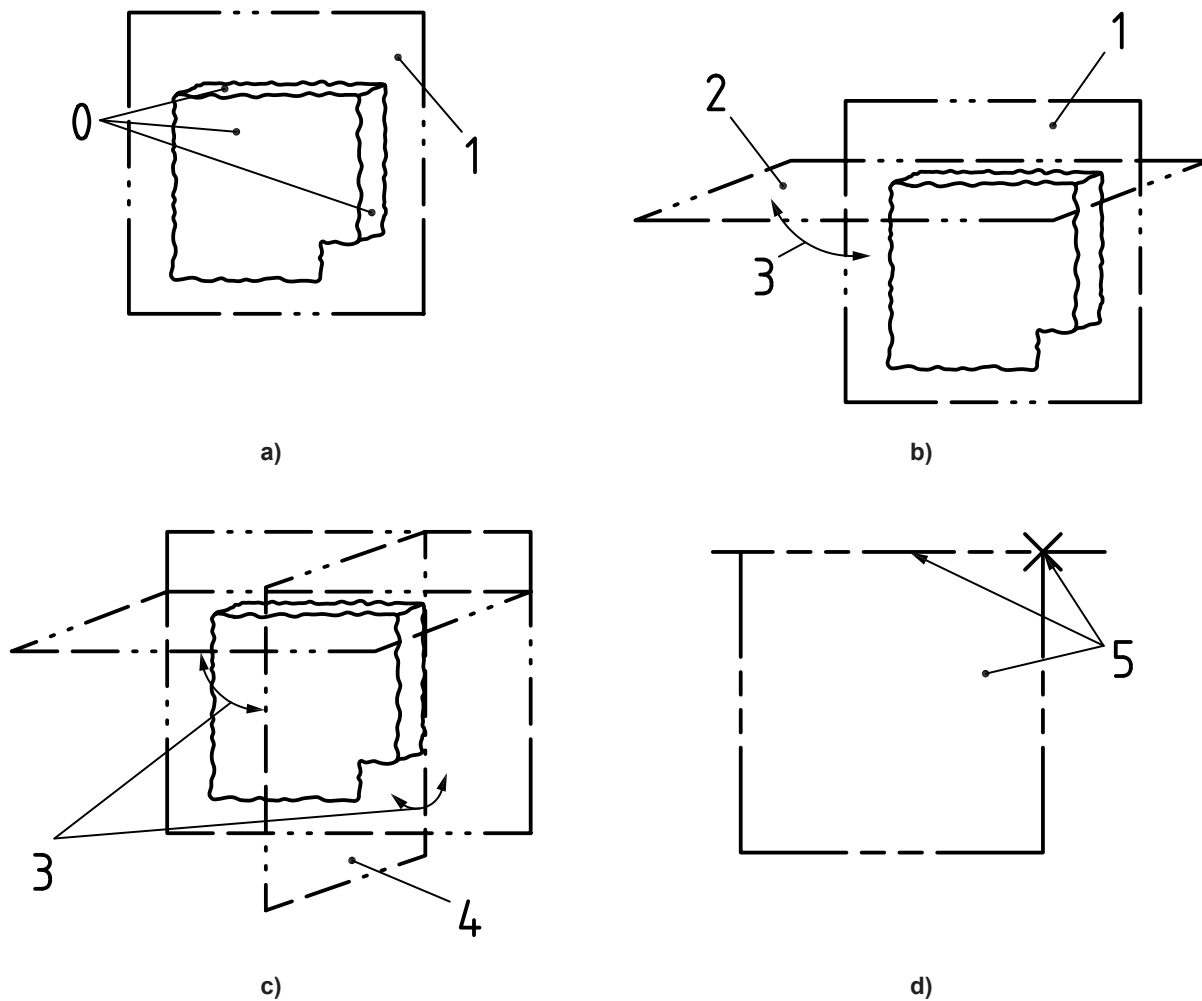

Figure C.36 — Three perpendicular planes — Set of three real integral surfaces

- According to 6.3.4, the datum system is characterized by the situation features of the collection of three planes associated with the real integral features with orientation constraints between them: angle of 90° . In the datum system, the primary datum is an associated plane [see Figure C.37 a)]; the secondary datum is an associated plane that respects the orientation constraint from the primary single datum [see Figure C.37 b)]; the tertiary datum is an associated plane which respects the orientation constraint firstly from the primary datum and secondly from the secondary datum [see Figure C.37 c)].

The invariance class of the collection of nominal surfaces that make up the datum system is complex and the situation features are a plane (corresponding to the primary datum), a straight line (the intersection between this plane and the plane corresponding to the secondary datum) and a point (the intersection between the straight line of the secondary datum and the plane corresponding to the tertiary datum) [see Figure C.37 d)].



Key

- 0 datum features: real integral features
- 1 associated plane (primary datum in this case) to the datum feature identified by the datum letter A
- 2 associated plane (secondary datum in this case) identified by the datum letter B, with orientation constraint from the primary datum
- 3 orientation constraint (perpendicularity)
- 4 associated plane (tertiary datum in this case) identified by the datum letter C, with orientation constraints from the primary datum and secondary datum
- 5 datum system: plane (primary datum), straight line (intersection between the primary and secondary datum) and point (intersection of the three datums)

Figure C.37 — Establishing a datum system from three perpendicular planes

C.3.2 Perpendicular plane and cylinder

Figure C.38 illustrates the drawing indication of the design intent.

Design intent (writing input)

Use two integral features, which are a nominally planar surface (which is not a feature of size) and a cylindrical surface (which is a feature of size) respectively, which are nominally perpendicular to each other, to establish two datums by considering the size of the cylinder variable and the orientation constraint (perpendicularity) between the axis of the associated cylinder and the associated plane. The datums are sequentially used in a given order to orient and/or locate the tolerance zone relative to a straight line and one of its points. The axis and the point are the situation features of the collection of the two associated features.

Drawing indication (reading input)

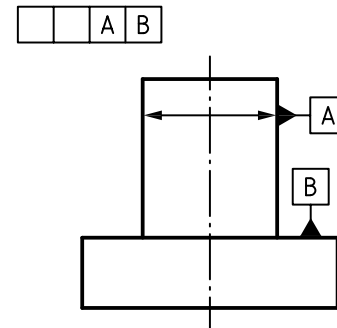

Figure C.38 — Cylinder and perpendicular plane — Input for reading (drawing indication) and for writing (design intent)

Explanation:

- The real integral surfaces are obtained after partition/extraction and collection (see Figure C.39).

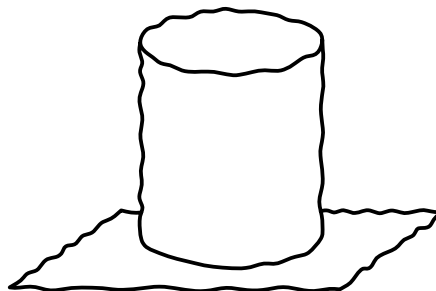
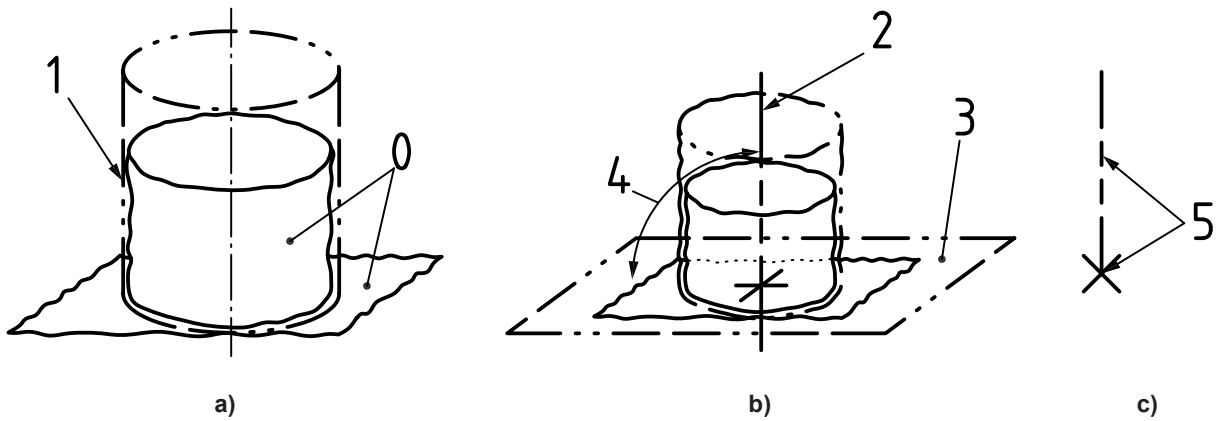

Figure C.39 — Perpendicular plane and cylinder — Set of two real integral surfaces

- According to 6.3.4, the datum system is characterized by the situation features of the collection of a plane and a cylinder perpendicular to each other, associated with the real integral features, with an orientation constraint between them: angle of 90° . In the datum system, the primary datum is an associated cylinder [see Figure C.40 a)]; the secondary datum is an associated plane which respects the orientation constraint from the primary single datum [see Figure C.40 b)].
- The invariance class of the collection of nominal surfaces is revolutes and the situation features are the axis of the cylinder and the point resulting from the intersection between the axis and the plane [see Figure C.40 c)].



Key

- 0 datum features: real integral features
- 1 associated cylinder to the datum feature
- 2 primary datum (axis of the associated cylinder)
- 3 associated plane (secondary datum in this case) with orientation constraint from the primary datum
- 4 orientation constraint (perpendicularity)
- 5 datum system: straight line (primary datum) and point (intersection between the primary and secondary datum)

Figure C.40 — Establishing a datum system from a cylinder and a perpendicular plane

Annex D (informative)

Former practices

D.1 Indication of a specific cross section of a cylinder as a datum feature

It was former practice to indicate the specific cross section of a cylinder as shown in Figure D.1.

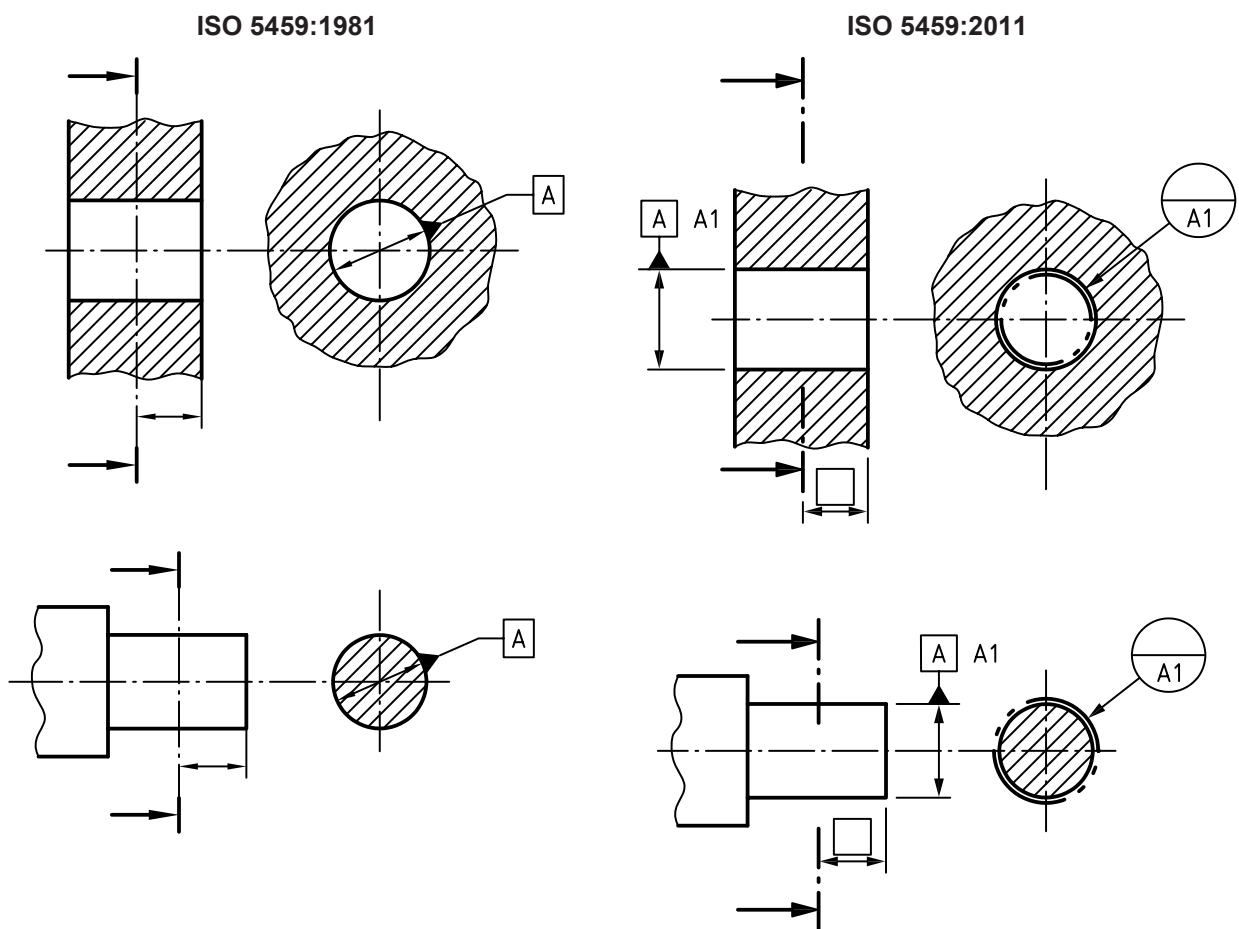

Figure D.1 — Indication of the centre of a cylinder

D.2 Datum target line indication

It was former practice, for target lines, to connect the two crosses with a continuous narrow line, as shown in Figure D.2.



Figure D.2 — Connection of two crosses

D.3 Common datum indication

It was former practice to indicate a common datum established from a group of features with an indication of single datum, as shown in Figure D.3.

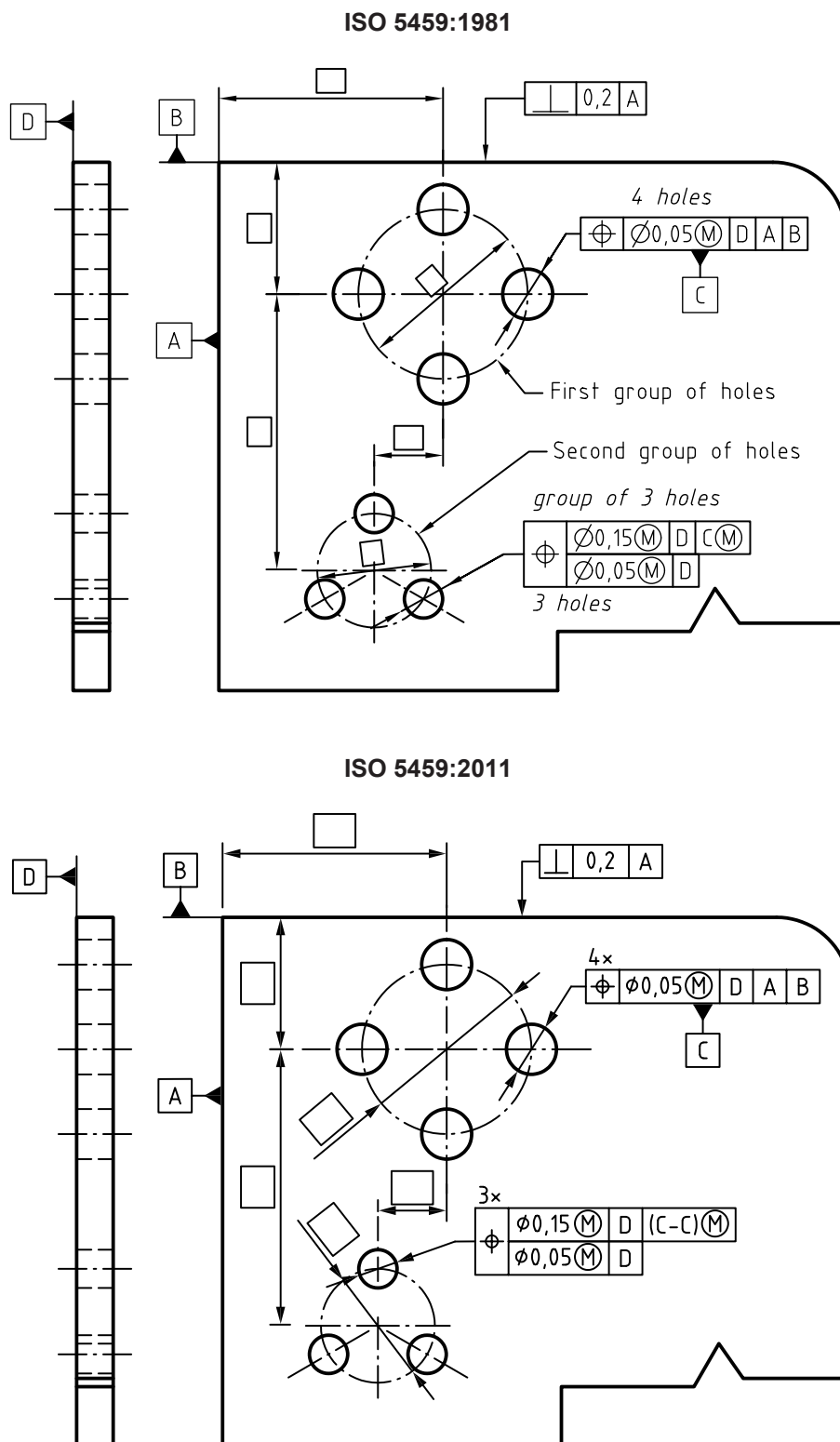
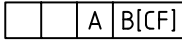
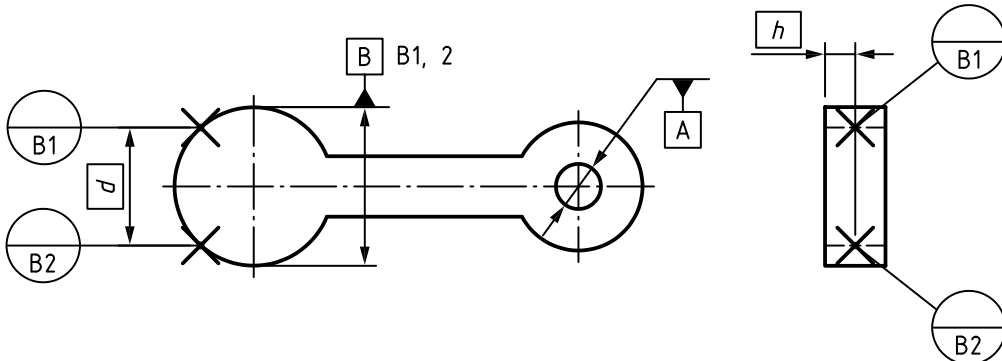
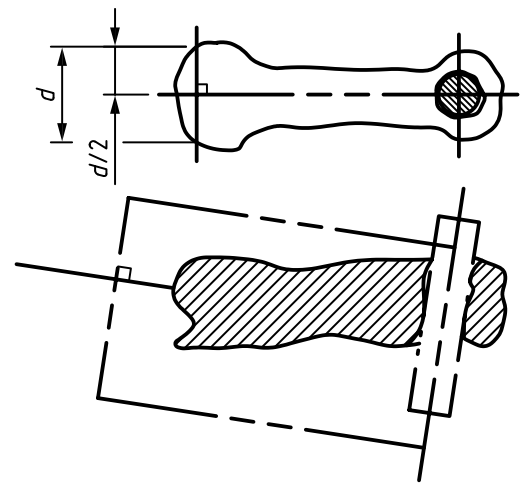

Figure D.3 — Indication of a common datum

Annex E
(informative)

Examples of a datum system or a common datum established with contacting features

E.1 Example 1

<p>Indication in the tolerance frame</p>	
<p>Example of indication on the drawing</p>	
<p>Meaning</p>	<p>The datum system should be established in the following manner.</p> <ul style="list-style-type: none"> – First, associate a cylinder to the extracted surface, which is identified by the datum letter “A”. The primary datum is the axis of the associated cylinder (defining an axis of rotation for a coordinate system). – Second, associate a set of two points, the distance between which is fixed as “<i>d</i>” with a TED. The manner in which the datum targets are dimensioned results in the intersection between the real surface and two straight lines, which are perpendicular to the primary datum axis and TED “<i>d</i>” apart (illustrated below). The secondary datum is a plane bisecting the distance between the datum target points and containing the primary datum axis (defining a stop in rotation for a coordinate system). <p>The datum system is a set consisting of a straight line and a coincident plane.</p>
<p>Illustration</p>	

E.2 Example 2

Indication in the tolerance frame	
Example of indication on the drawing	
Meaning	<p>The datum system should be established in the following manner.</p> <ul style="list-style-type: none"> – First, associate a cylinder with the datum feature, which is identified by the datum letter “A”. The primary datum is the axis of the associated cylinder (defining an axis of rotation for a coordinate system). – Second, associate a set of two segments, the distance between which is variable. The manner in which the datum targets are dimensioned results in the intersection between the real surface and the two planes producing the wedge angle α. The line of intersection between the two planes of the wedge is parallel to the primary datum axis. The secondary datum is a bisector plane containing the primary datum axis (defining a stop in rotation for a coordinate system). <p>The datum system is a set consisting of a straight line and a coincident plane.</p>
Illustration	

E.3 Example 3

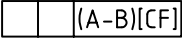
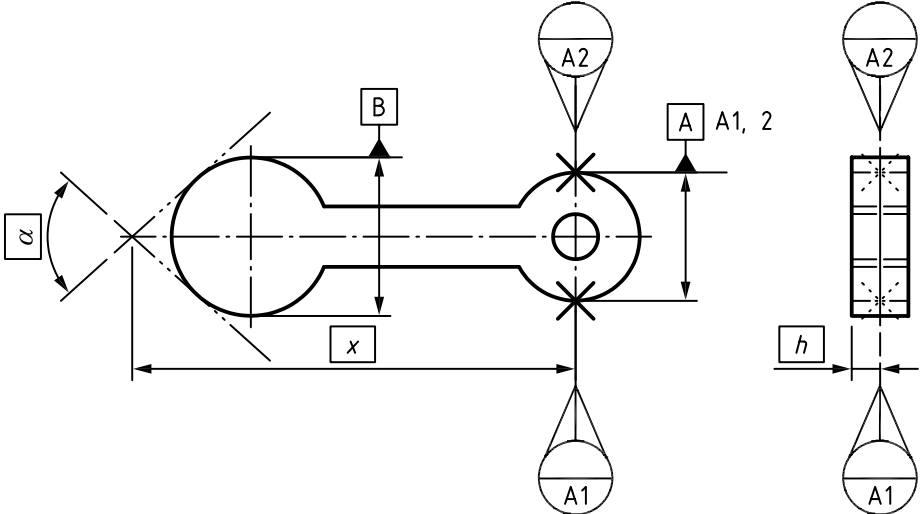
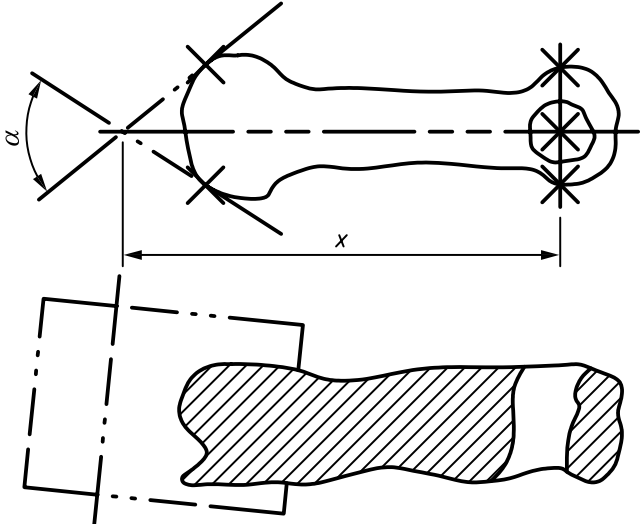
<p>Indication in the tolerance frame</p>	
<p>Example of indication on the drawing</p>	
<p>Meaning</p>	<p>The common datum should be established by associating two contacting features simultaneously with the real surface of the workpiece.</p> <p>The first contacting feature is a wedge with a fixed angle providing two datum targets, the distance between which is variable. The second contacting feature is a set of two datum targets, where the distance between the apex of the wedge and the points is fixed by a TED. (The first contacting feature generates nominally a datum line at the intersection of the wedge angle and leaves a degree of freedom in rotation, while the second contacting feature removes this remaining degree of freedom with a median feature.)</p> <p>The median plane of the wedge is coincident with the median point constructed from the two datum targets.</p> <p>The datum system is a set consisting of two perpendicular planes.</p>
<p>Illustration</p>	

E.4 Example 4

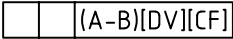
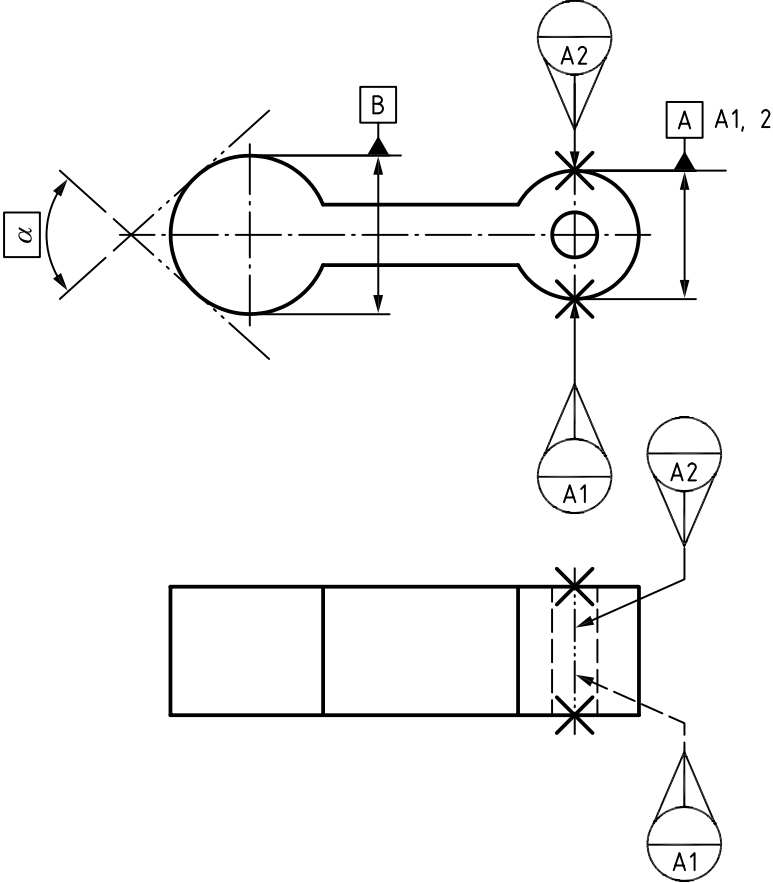
<p>Indication in the tolerance frame</p>	
<p>Example of indication on the drawing</p>	
<p>Meaning</p>	<p>The common datum should be established by associating two contacting features simultaneously with the real surface of the workpiece.</p> <p>The first contacting feature is a wedge with a fixed angle providing two datum targets, the distance between which is variable. The second contacting feature is a set of two parallel planes, defining as interface with the part two datum target lines. (The first contacting feature generates a datum line at the intersection of the wedge angle and leaves a degree of freedom in rotation, while the second contacting feature removes this remaining degree of freedom with a median feature.)</p> <p>The median plane of the wedge contains the median line constructed from the two datum targets. With the modifier [DV], the distance between the apex line of the wedge and median line is not fixed.</p> <p>The datum system is a set consisting of two perpendicular planes.</p>

Illustration

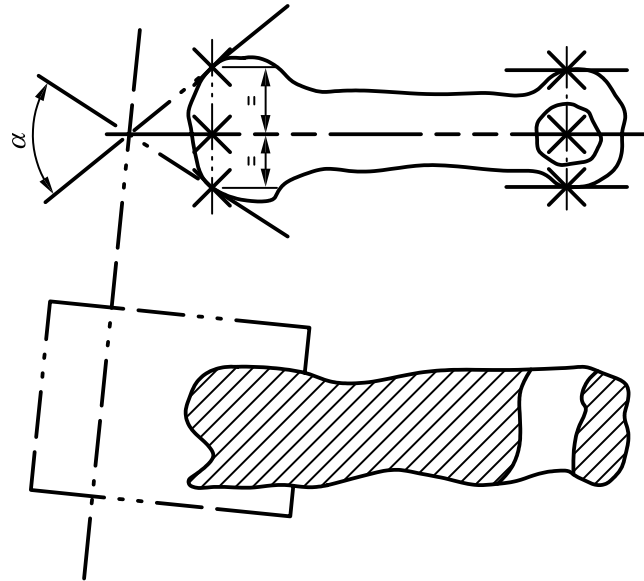

E.5 Example 5 — Example for a “three jaw chuck”

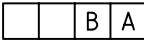
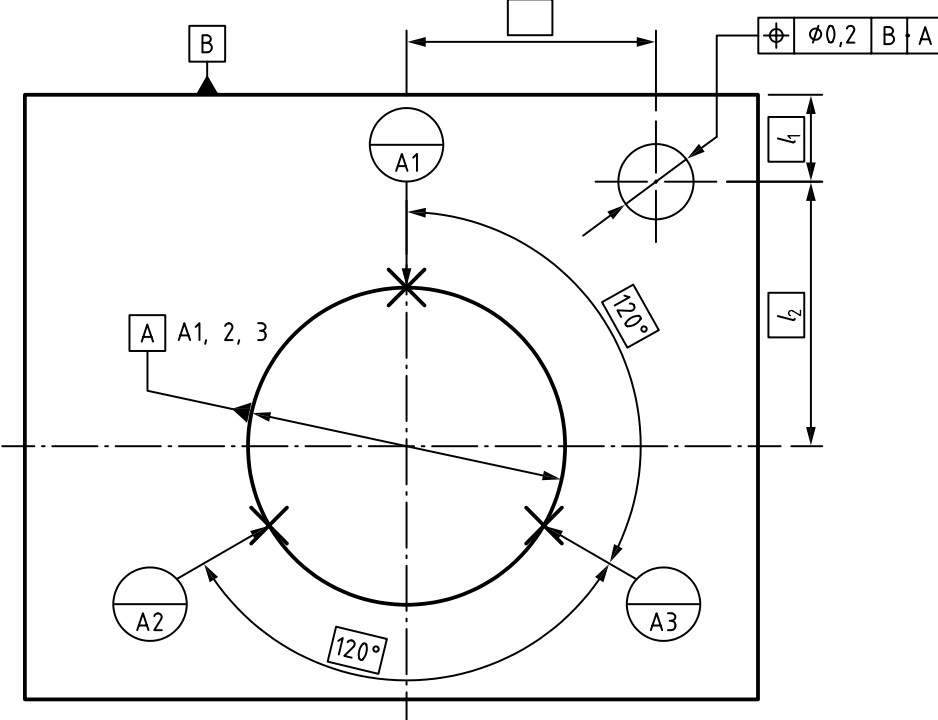
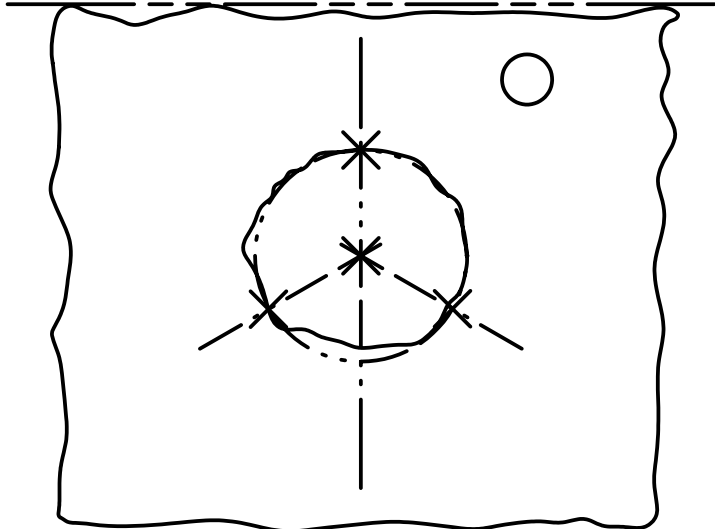
<p>Indication in the tolerance frame</p>	
<p>Example of indication on the drawing</p>	
<p>Meaning</p>	<p>The datum system should be established by associating a plane, and associating a cylinder, established from three datum target lines. To define datum targets A1, A2 and A3, it is necessary to construct the intersections between three straight lines constrained in orientation by TEDs (120°) and coinciding at the same point.</p> <p>The datum system is a set consisting of a plane and a perpendicular straight line (axis of the associated cylinder constrained in orientation from the datum B).</p>
<p>Illustration</p>	

Annex F (normative)

Relations and dimensions of graphical symbols

In order to harmonize the sizes of the symbols specified in this International Standard with those of the other inscriptions on the drawing (dimensions, letters, tolerances), the rules given in Figure F.1 shall be observed. These rules are in accordance with ISO 81714-1. The letters dn denote the narrow line width.

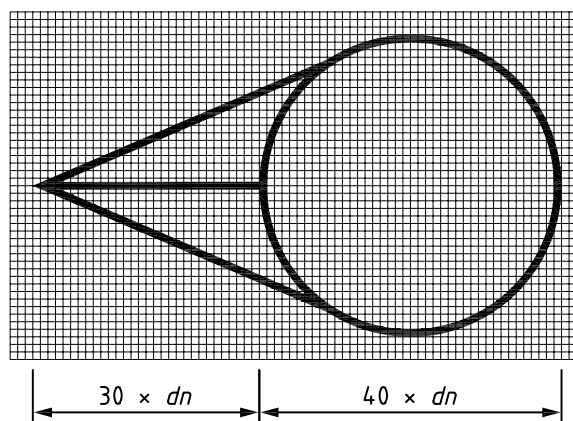

Figure F.1 — Moveable target frame

Annex G (informative)

Relationship to the GPS matrix model

G.1 General

For full details about the GPS matrix model, see ISO/TR 14638.

The ISO/GPS Masterplan given in ISO/TR 14638 gives an overview of the ISO/GPS system of which this standard is a part. The fundamental rules of ISO/GPS given in ISO 8015 apply to this standard and the default decision rules given in ISO 14253-1 apply to specifications made in accordance with this standard, unless otherwise indicated.

G.2 Information about this International Standard and its use

This International Standard describes the terminology, the rules, the explanations and the manner in which datums and datum systems are indicated in technical product documentation.

G.3 Position in the GPS matrix model

This International Standard is a general GPS standard that influences chain links 1 to 3 of the chains of standards on datums in the general GPS matrix, as graphically illustrated on Figure G.1.

Global GPS standards	
General GPS matrix	
Chain link number	1 2 3 4 5 6
Size	
Distance	
Radius	
Angle	
Form of line independent of datum	
Form of line dependent on datum	
Form of surface independent of datum	
Form of surface dependent on datum	
Orientation	
Location	
Circular run-out	
Total run-out	
Datums	
Roughness profile	
Waviness profile	
Primary profile	
Surface imperfections	
Edges	

Figure G.1 — Position in the GPS matrix model

G.4 Related International Standards

The related International Standards are those of the chains of standards indicated in Figure G.1.

Bibliography

- [1] ISO 2768-1, *General tolerances — Part 1: Tolerances for linear and angular dimensions without individual tolerance indications*
- [2] ISO 2768-2, *General tolerances — Part 2: Geometrical tolerances for features without individual tolerance indications*
- [3] ISO 5459:1981, *Technical drawings — Geometrical tolerancing — Datums and datum systems for geometrical tolerances*
- [4] ISO 7083:1983, *Technical drawings — Symbols for geometrical tolerancing — Proportions and dimensions*
- [5] ISO 8015, *Geometrical product specifications (GPS) — Fundamentals — Concepts, principles and rules*
- [6] ISO 14253-1, *Geometrical product specifications (GPS) — Inspection by measurement of workpieces and measuring equipment — Part 1: Decision rules for proving conformance or non-conformance with specifications*
- [7] ISO/TR 14638, *Geometrical product specification (GPS) — Masterplan*

British Standards Institution (BSI)

BSI is the national body responsible for preparing British Standards and other standards-related publications, information and services.

BSI is incorporated by Royal Charter. British Standards and other standardization products are published by BSI Standards Limited.

About us

We bring together business, industry, government, consumers, innovators and others to shape their combined experience and expertise into standards-based solutions.

The knowledge embodied in our standards has been carefully assembled in a dependable format and refined through our open consultation process. Organizations of all sizes and across all sectors choose standards to help them achieve their goals.

Information on standards

We can provide you with the knowledge that your organization needs to succeed. Find out more about British Standards by visiting our website at bsigroup.com/standards or contacting our Customer Services team or Knowledge Centre.

Buying standards

You can buy and download PDF versions of BSI publications, including British and adopted European and international standards, through our website at bsigroup.com/shop, where hard copies can also be purchased.

If you need international and foreign standards from other Standards Development Organizations, hard copies can be ordered from our Customer Services team.

Subscriptions

Our range of subscription services are designed to make using standards easier for you. For further information on our subscription products go to bsigroup.com/subscriptions.

With **British Standards Online (BSOL)** you'll have instant access to over 55,000 British and adopted European and international standards from your desktop. It's available 24/7 and is refreshed daily so you'll always be up to date.

You can keep in touch with standards developments and receive substantial discounts on the purchase price of standards, both in single copy and subscription format, by becoming a **BSI Subscribing Member**.

PLUS is an updating service exclusive to BSI Subscribing Members. You will automatically receive the latest hard copy of your standards when they're revised or replaced.

To find out more about becoming a BSI Subscribing Member and the benefits of membership, please visit bsigroup.com/shop.

With a **Multi-User Network Licence (MUNL)** you are able to host standards publications on your intranet. Licences can cover as few or as many users as you wish. With updates supplied as soon as they're available, you can be sure your documentation is current. For further information, email bsmusales@bsigroup.com.

BSI Group Headquarters

389 Chiswick High Road London W4 4AL UK

Revisions

Our British Standards and other publications are updated by amendment or revision.

We continually improve the quality of our products and services to benefit your business. If you find an inaccuracy or ambiguity within a British Standard or other BSI publication please inform the Knowledge Centre.

Copyright

All the data, software and documentation set out in all British Standards and other BSI publications are the property of and copyrighted by BSI, or some person or entity that owns copyright in the information used (such as the international standardization bodies) and has formally licensed such information to BSI for commercial publication and use. Except as permitted under the Copyright, Designs and Patents Act 1988 no extract may be reproduced, stored in a retrieval system or transmitted in any form or by any means – electronic, photocopying, recording or otherwise – without prior written permission from BSI. Details and advice can be obtained from the Copyright & Licensing Department.

Useful Contacts:

Customer Services

Tel: +44 845 086 9001

Email (orders): orders@bsigroup.com

Email (enquiries): cservices@bsigroup.com

Subscriptions

Tel: +44 845 086 9001

Email: subscriptions@bsigroup.com

Knowledge Centre

Tel: +44 20 8996 7004

Email: knowledgecentre@bsigroup.com

Copyright & Licensing

Tel: +44 20 8996 7070

Email: copyright@bsigroup.com



...making excellence a habit.™