

# Mechanical vibration — Measurement and evaluation of human exposure to hand-transmitted vibration —

**Part 2: Practical guidance for  
measurement at the workplace**

ICS 13.160; 17.160

## National foreword

This British Standard is the UK implementation of EN ISO 5349-2:2001+A1:2015. It is identical to ISO 5349-2:2001, incorporating amendment 1:2015. It supersedes BS EN ISO 5349-2:2002, which is withdrawn.

The start and finish of text introduced or altered by amendment is indicated in the text by tags. Tags indicating changes to ISO text carry the number of the ISO amendment. For example, text altered by ISO amendment 1 is indicated by **A1** **A1**.

The UK participation in its preparation was entrusted by Technical Committee GME/21, Mechanical vibration, shock and condition monitoring, to Subcommittee GME/21/6, Mechanical vibration, shock and condition monitoring – Human exposure to mechanical vibration and shock.

A list of organizations represented on this subcommittee can be obtained on request to its secretary.

This publication does not purport to include all the necessary provisions of a contract. Users are responsible for its correct application.

**Compliance with a British Standard cannot confer immunity from legal obligations.**

This British Standard, having been prepared under the direction of the Engineering Sector Policy and Strategy Committee, was published under the authority of the Standards Policy and Strategy Committee on 11 February 2002

© The British Standards Institution 2015.  
Published by BSI Standards Limited 2015

### Amendments/corrigenda issued since publication

| Date           | Comments  |
|----------------|---|
| 31 August 2015 | Implementation of ISO amendment 1:2015 with CEN endorsement A1:2015. BSI, CEN and ISO identifiers aligned |
|                |   |
|                |   |
|                |   |

ICS 13.160

English version

**Mechanical vibration - Measurement and evaluation of human exposure to hand-transmitted vibration - Part 2: Practical guidance for measurement at the workplace (ISO 5349-2:2001)**

Vibrations mécaniques - Mesurage et évaluation de l'exposition des individus aux vibrations transmises par la main - Partie 2: Guide pratique pour le mesurage sur le lieu de travail (ISO 5349-2:2001)

Mechanische Schwingungen - Messung und Bewertung der Einwirkung von Schwingungen auf das Hand-Arm-System des Menschen - Teil 2: Praxisgerechte Anleitung zur Messung am Arbeitsplatz (ISO 5349-2:2001)

This European Standard was approved by CEN on 22 June 2001.

CEN members are bound to comply with the CEN/CENELEC Internal Regulations which stipulate the conditions for giving this European Standard the status of a national standard without any alteration. Up-to-date lists and bibliographical references concerning such national standards may be obtained on application to the Management Centre or to any CEN member.

This European Standard exists in three official versions (English, French, German). A version in any other language made by translation under the responsibility of a CEN member into its own language and notified to the Management Centre has the same status as the official versions.

CEN members are the national standards bodies of Austria, Belgium, Czech Republic, Denmark, Finland, France, Germany, Greece, Iceland, Ireland, Italy, Luxembourg, Netherlands, Norway, Portugal, Spain, Sweden, Switzerland and United Kingdom.



EUROPEAN COMMITTEE FOR STANDARDIZATION  
COMITÉ EUROPÉEN DE NORMALISATION  
EUROPÄISCHES KOMITEE FÜR NORMUNG

**Management Centre: rue de Stassart, 36 B-1050 Brussels**

## Contents

|  | page                |
|--|---------------------|
| Foreword.....  | 3                   |
| Introduction.....  | 4                   |
| <b>1 Scope .....</b>   | <b>5</b>            |
| <b>A1</b> <b>2 Normative references.....</b>   | <b>5</b> <b>A1</b>  |
| <b>3 Terms and definitions and symbols.....</b>  | <b>5</b>            |
| 3.1 Terms and definitions.....   | 5                   |
| 3.2 Symbols .....  | 6                   |
| <b>4 Quantities to be evaluated.....</b>   | <b>6</b>            |
| <b>5 Preparation of the measurement procedure.....</b>   | <b>7</b>            |
| 5.1 General .....  | 7                   |
| 5.2 Selection of operations to be measured .....   | 7                   |
| 5.3 Organization of the measurements .....   | 8                   |
| 5.4 Duration of vibration measurements .....   | 9                   |
| 5.5 Estimation of daily vibration duration.....  | 10                  |
| <b>6 Measurement of vibration magnitude.....</b>   | <b>11</b>           |
| 6.1 Measurement equipment.....   | 11                  |
| 6.2 Sources of uncertainty in vibration measurement.....   | 16                  |
| 6.3 Check and verification of the measurement chain.....   | 17                  |
| <b>7 Uncertainty of evaluation of daily vibration exposure.....</b>                                  | <b>17</b>           |
| 7.1 Acceleration measurement uncertainty.....  | 17                  |
| 7.2 Exposure time measurement uncertainty .....  | 18                  |
| 7.3 Evaluation of uncertainties .....  | 18                  |
| <b>8 Calculation of the daily vibration exposure .....</b>   | <b>19</b>           |
| <b>9 Information to be reported .....</b>  | <b>19</b>           |
| <b>A1</b> <b>Annex A (informative) Examples of measurement locations .....</b>                       | <b>22</b> <b>A1</b> |
| <b>Annex B (informative) Evaluation of vibration exposure over periods greater than one day.....</b> | <b>33</b>           |
| <b>Annex C (informative) Mechanical filters .....</b>  | <b>35</b>           |
| <b>Annex D (informative) Guidance on mounting accelerometers.....</b>                                | <b>36</b>           |
| <b>Annex E (informative) Examples of the calculation of daily vibration exposure.....</b>            | <b>39</b>           |
| <b>Bibliography .....</b>  | <b>47</b>           |

## Foreword

The text of EN ISO 5349-2:2001 has been prepared by Technical Committee CEN/TC 231 "Mechanical vibration and shock", the secretariat of which is held by DIN, in collaboration with Technical Committee ISO/TC 108 "Mechanical vibration and shock".

This European Standard shall be given the status of a national standard, either by publication of an identical text or by endorsement, at the latest by February 2002, and conflicting national standards shall be withdrawn at the latest by February 2002.

Users of this EN, prepared in the field of application of Article 137 (formerly 118a) of the EC Treaty, should be aware that standards have no formal legal relationship with Directives which may have been made under Article 137 of the Treaty. In addition, national legislation in the Member states may contain more stringent requirements than the minimum requirements of a Directive based on Article 137. Information on the relationship between the national legislation implementing Directives based on Article 137 and this EN may be given in a national foreword of the national standard implementing this EN.

Annexes A to E of this European Standard are informative.

According to the CEN/CENELEC Internal Regulations, the national standards organizations of the following countries are bound to implement this European Standard: Austria, Belgium, Czech Republic, Denmark, Finland, France, Germany, Greece, Iceland, Ireland, Italy, Luxembourg, Netherlands, Norway, Portugal, Spain, Sweden, Switzerland and the United Kingdom.

## Foreword to amendment A1

This document (EN ISO 5349-2:2001/A1:2015) has been prepared by Technical Committee ISO/TC 108 "Mechanical vibration, shock and condition monitoring" in collaboration with Technical Committee CEN/TC 231 "Mechanical vibration and shock" the secretariat of which is held by DIN.

This Amendment to the European Standard EN ISO 5349-2:2001 shall be given the status of a national standard, either by publication of an identical text or by endorsement, at the latest by January 2016, and conflicting national standards shall be withdrawn at the latest by January 2016.

Attention is drawn to the possibility that some of the elements of this document may be the subject of patent rights. CEN [and/or CENELEC] shall not be held responsible for identifying any or all such patent rights.

According to the CEN-CENELEC Internal Regulations, the national standards organizations of the following countries are bound to implement this European Standard: Austria, Belgium, Bulgaria, Croatia, Cyprus, Czech Republic, Denmark, Estonia, Finland, Former Yugoslav Republic of Macedonia, France, Germany, Greece, Hungary, Iceland, Ireland, Italy, Latvia, Lithuania, Luxembourg, Malta, Netherlands, Norway, Poland, Portugal, Romania, Slovakia, Slovenia, Spain, Sweden, Switzerland, Turkey and the United Kingdom.

## Endorsement notice

The text of ISO 5349-2:2001/Amd 1:2015 has been approved by CEN as EN ISO 5349-2:2001/A1:2015 without any modification.

## **Introduction**

Operating machinery may expose workers to hand-transmitted mechanical vibration which can interfere with comfort, working efficiency and, in some circumstances, health and safety. The general requirements for measuring and evaluating hand-transmitted vibration exposure are specified in ISO 5349-1. The aim of the present part of ISO 5349 is to provide practical guidelines in accordance with ISO 5349-1 to perform measurements correctly and to develop an effective strategy for measurement of hand-transmitted vibration at the workplace.

The use of the strategy described in this part of ISO 5349 will lead to a realistic picture of the daily exposure of the operator at the workplace and of the relevant uncertainties.

The evaluation of vibration exposure can be broken up into a number of distinct stages:

- identifying a series of discrete operations which make up the subject's normal working pattern;
- selection of operations to be measured;
- measuring the r.m.s. acceleration value for each selected operation;
- evaluation of the typical daily exposure time for each operation identified;
- calculating the 8-h energy-equivalent vibration total value (daily vibration exposure).

The evaluation of vibration exposure as described in ISO 5349-1 is solely based on the measurement of vibration magnitude at the grip zones or handles and exposure times. Additional factors, such as gripping and feed forces applied by the operator, the posture of the hand and arm, the direction of the vibration and the environmental conditions, etc. are not taken into consideration. This part of ISO 5349, being an application of ISO 5349-1, does not define guidance to evaluate these additional factors. However, it is recognized that reporting of all relevant information is important for the development of improved methods for the assessment of vibration risk.

## 1 Scope

This part of ISO 5349 provides guidelines for the measurement and evaluation of hand-transmitted vibration at the workplace in accordance with ISO 5349-1.

This part of ISO 5349 describes the precautions to be taken to make representative vibration measurements and to determine the daily exposure time for each operation in order to calculate the 8-h energy-equivalent vibration total value (daily vibration exposure). This part of ISO 5349 provides a means to determine the relevant operations which should be taken into account when determining the vibration exposure.

This part of ISO 5349 applies to all situations where people are exposed to vibration transmitted to the hand-arm system by hand-held or hand-guided machinery, vibrating workpieces, or controls of mobile or fixed machinery.

## 2 Normative references

The following documents, in whole or in part, are normatively referenced in this document and are indispensable for its application. For dated references, only the edition cited applies. For undated references, the latest edition of the referenced document (including any amendments) applies.


ISO 2041, *Mechanical vibration, shock and condition monitoring — Vocabulary*

ISO 5349-1, *Mechanical vibration — Measurement and evaluation of human exposure to hand-transmitted vibration — Part 1: General requirements*

ISO 5805, *Mechanical vibration and shock — Human exposure — Vocabulary*

ISO 8041, *Human response to vibration — Measuring instrumentation*

ISO 22867, *Forestry and gardening machinery — Vibration test code for portable hand-held machines with internal combustion engine — Vibration at the handles*

ISO 28927 (all parts), *Hand-held portable power tools — Test methods for evaluation of vibration emission* 

## 3 Terms and definitions and symbols

### 3.1 Terms and definitions

For the purposes of this part of ISO 5349, the terms and definitions given in ISO 2041 and ISO 5805 and the following apply.

#### 3.1.1

##### **hand-fed machine**

machine where the operator feeds workpieces to the working part of the machine, such that the vibration exposure is obtained through the hand-held workpiece

EXAMPLE band-saw, pedestal grinder

#### 3.1.2

##### **hand-guided machine**

machine which is guided by the operator with his hands, such that the vibration exposure is obtained through the handles, steering wheel or tiller

EXAMPLE ride-on lawn mower, powered pallet truck, swing grinder

### 3.1.3

#### **hand-held workpiece**

workpiece which is held in the hand, such that vibration exposure is obtained through the hand-held workpiece rather than, or as well as, through the power tool handle

EXAMPLE casting held against a pedestal grinder, wood fed into a band-saw

### 3.1.4

#### **hand-held power tool**

powered tool which is held in the hand

EXAMPLE electric drill, pneumatic chisel, chain saw

### 3.1.5

#### **inserted tool**

interchangeable or replaceable attachment which fits into or onto a power tool or machine

EXAMPLE drill bit, chisel, chain saw chain, saw-blade, abrasive wheel

### 3.1.6

#### **operation**

identifiable task for which a representative vibration magnitude measurement is made, this may be for the use of a single power tool, or hand-held workpiece type or for a single phase of a task

### 3.1.7

#### **operator**

person using a hand-fed, hand-guided or hand-held machine or power tool

### 3.1.8

#### **tool operation**

any period during which a power tool is operating and the operator is being exposed to hand-transmitted vibration

### 3.1.9

#### **workpiece**

item being operated upon by a power tool

## 3.2 Symbols

In this part of ISO 5349, the following symbols are used:

$a_{hwi}$  single-axis root-mean-square (r.m.s.) value of the frequency-weighted hand-transmitted vibration for operation  $i$ , in  $m/s^2$ . An additional suffix  $x$ ,  $y$  or  $z$  is used to indicate the direction of the measurement, i.e.  $a_{hwix}$ ,  $a_{hwiy}$  and  $a_{hwiz}$

$a_{hvi}$  vibration total value (formerly denoted vector sum or frequency-weighted acceleration sum) for operation  $i$  (root-sum-of-squares of the  $a_{hwi}$  values for the three axes of vibration), in  $m/s^2$

$A(8)$  daily vibration exposure, in  $m/s^2$

$A_i(8)$  contribution of operation  $i$  to the daily vibration exposure, in  $m/s^2$  (for convenience, this is referred to as the "partial vibration exposure")

$T_0$  reference duration of 8 h (28800 s)

$T_i$  total duration (per day) of vibration exposure to operation  $i$ .

## 4 Quantities to be evaluated

There are two principal quantities to be evaluated for each operation  $i$  during exposure to vibration:



- the vibration total value  $a_{hvi}$ , expressed in metres per second squared ( $m/s^2$ ); this value is calculated from the three single-axis root-mean-square values of the frequency-weighted hand-transmitted vibration  $a_{hwix}$ ,  $a_{hwiy}$  and  $a_{hwiz}$ ;
- the duration (per day)  $T_i$  of vibration exposure to operation  $i$ .

The principal parameter to be reported is the daily vibration exposure  $A(8)$ . This is calculated from the values of  $a_{hvi}$  and  $T_i$  for all operations  $i$  (see clause 8).

## 5 Preparation of the measurement procedure

### 5.1 General

The work of an operator at a workplace is composed of a series of operations, some of which may be repeated. The vibration exposure may vary greatly from one operation to another, either due to the use of different power tools or machines or different modes of operation of one power tool or machine.

To evaluate daily vibration exposure, it is first necessary to identify the operations which are likely to contribute significantly to the overall vibration exposure. For each of these operations, it is then necessary to decide on procedures for measuring the vibration exposure. The methods to be used will depend on the characteristics of the work environment, the work pattern and the vibration source.

### 5.2 Selection of operations to be measured

It is important to make measurements for all the power tools or workpieces which may give a significant contribution to the daily vibration exposure. To obtain a good picture of the average daily vibration exposure it is necessary to identify all

- a) sources of vibration exposure (i.e. the machines and tools being used);
- b) modes of operation of the power tool, e.g.:
  - chain saws may be idling, operating under load while cutting through a tree trunk, or operating under low load while cutting side branches,
  - a power drill may be used in impactive or non-impactive modes and may have a range of speed settings available;
- c) changes in the operating conditions where this might affect vibration exposure, e.g.:
  - a road breaker being used initially on a hard concrete surface followed by use on the softer soil underneath,
  - a grinder being used initially for bulk metal removal followed by more intricate operations of cleaning and shaping;
- d) inserted tools which might affect vibration exposure, e.g.:
  - a sander may be used with a series of different grades of abrasive paper, ranging from coarse to fine,
  - a stonemason may use a pneumatic chisel with a range of different chisel bits.

In addition, it can be useful to obtain

- e) information from workers and supervisors on which situations they believe produce the highest vibration magnitude;
- f) estimates of the potential vibration hazards for each operation, using information from manufacturers on vibration emission values, see annex A, or using published results of previous measurements on similar power tools.

### **5.3 Organization of the measurements**

The organization of measurements can be approached in four basic ways:

- a) Long-term measurement of continuous tool operation

The operation time is long and continuous, and during this time the operator maintains contact with the vibrating surface. In this case the vibration measurement can be made over long periods during the normal use of the power tool. The operation may include changes in vibration magnitude, provided that they are part of the normal working procedure.

In addition to vibration magnitude information, the evaluation of daily vibration exposure requires an evaluation of the duration of exposure to vibration per day.

- b) Long-term measurement of intermittent tool operation

The operation time is long but includes short breaks where there is no vibration exposure, however, during the operation and breaks the operator maintains contact with the (vibrating) surface. In this case the vibration measurement can be made over long periods during the normal use of the power tool, provided that any breaks in operation are part of the normal working procedure and that the operator does not lose contact with the power tool or hand-held workpiece, or significantly alter position of his hands on the power tool or hand-held workpiece.

In addition to vibration magnitude information, the evaluation of daily vibration exposure requires an evaluation of the duration of exposure to the operation per day. In this case the duration of exposure to the operation includes the short breaks in vibration exposure and so will be longer than the duration of exposure to vibration.

- c) Short-term measurement of intermittent tool operation

In many situations the hand is often taken off the power tool or hand-held workpiece, e.g. the power tool is put down, the hand is moved to a different part of the power tool, or another hand-held workpiece is picked up. In other situations, changes have to be made to the power tools being used, e.g. different abrasive belts or drill bits fitted or alternative power tools used. In these cases short-term measurements can only be made during each phase of the work operation.

In some cases it is difficult, or impossible, to get reliable measurements during the normal work process, due to the exposure durations being too short for measurement purposes. In this case measurements may be made during simulated work operations which artificially arrange longer uninterrupted exposures with work conditions as near to normal as possible.

In addition to vibration magnitude information, the evaluation of daily vibration exposure requires an evaluation of the exposure duration associated with each work phase.

- d) Fixed-duration measurement of bursts of tool operation or single or multiple shocks

Some operations involve exposure to short-duration bursts of vibration exposure, this may be single or multiple shocks, such as riveting hammers, nail guns, etc., or bursts of exposure, such as powered impact wrenches. In such cases it is often difficult to make an evaluation of actual exposure times, although the number of bursts of vibration per day can be estimated. In this case measurements may be made over a fixed duration which includes one or more complete tool operations. The duration of measurement should include as little time before, between and after bursts of vibration as possible.

In addition to vibration magnitude information and the estimate of the number of bursts of vibration exposures per day, the evaluation of daily vibration exposure requires information on the measurement duration and the number of bursts of vibration during the measurement period.

NOTE 1 In the case of exposing the worker to multiple single shocks or transient vibration (e.g. fastening tools), the method described in ISO 5349-1 may not be adequate and underestimate the severity of shock exposure. However, in the absence of a better method, ISO 5349-1 may be applied but this should be done with caution and be indicated in the information to be reported.

NOTE 2 Where measurements of vibration magnitude are to be compared (e.g. to compare the vibration produced by two different power tool or inserted tool options) it is important to make measurements of continuous tool operation, i.e. with no breaks in vibration exposure.

## 5.4 Duration of vibration measurements

### 5.4.1 Measurement during normal working

A measurement should be an average over a period which is representative of the typical use of a power tool, machine or process. Where possible, the measurement period should start when the worker's hands first contact the vibrating surface, and should finish when the contact is broken. This period may include variations in the vibration magnitude and may even include periods when there is no exposure.

Where possible, a series of sample measurements should be taken at different times of the day, and averaged, so that variations in vibration through the day are accounted for.

NOTE The average vibration magnitude of a series of N vibration magnitude samples is given by

$$a_{hw} = \sqrt{\frac{1}{T} \sum_{j=1}^N a_{hwj}^2 t_j}$$

where

$a_{hwj}$  is the measured vibration magnitude for sample j

$t_j$  is the measurement duration of sample j

$$T = \sum_{j=1}^N t_j$$

Vibration exposures are often for short periods, which are repeated many times during a working day. Although measurements can be averaged over complete cycles of operation (including periods when the vibration source is switched off), normally it is only possible to average over the short period that the hand is in contact with the vibrating surface.

The minimum acceptable duration of measurements depends on the signal, instrumentation and operation characteristics. The total measuring time (i.e. the number of samples multiplied by the duration per measurement) should be at least 1 min. A number of shorter duration samples should be taken in preference to a single long duration measurement. For each operation, at least three samples should be taken.

Measurements of very short duration (e.g. less than 8 s) are unlikely to be reliable, particularly in their evaluation of low-frequency components, and should be avoided where possible. Where very short duration measurements are unavoidable (e.g. certain types of pedestal grinding for which contact times can be very short), it is advisable to take many more than three samples to ensure a total sample time greater than 1 min.

## 5.4.2 Simulated work procedures

Where measurements are not possible, or difficult, during normal tool operation then simulated work procedures can be used to simplify the vibration measurement process.

The main use of simulated work procedures is to achieve measurements over longer periods than could be allowed during normal production work. For example, the pedestal grinding of small castings may only last a few seconds per casting; rather than try to measure for short durations on many castings it may be possible to simulate the grinding on a small number of scrap castings, using each scrap casting many times.

Picking up, putting down or replacing the power tool or hand-held workpiece may disturb the measurement. These disturbances may also be avoided by measuring during simulated work procedures which can be designed to avoid any interruptions between operations.

## 5.5 Estimation of daily vibration duration

The daily exposure duration for each vibration source shall be obtained. Often a typical daily vibration exposure time will be based on

- a measurement of the actual exposure time during a period of normal use (e.g. as evaluated over a complete work cycle, or during a typical 30 min period) and
- information on work rate (e.g. the number of work cycles per shift or the shift length).

The first of these will be a measurement to determine how long an operator is exposed to vibration, and from what source, during a specified period. Various techniques may be used, for example:

- use of a stopwatch;
- use of a dedicated data logger linked to power tool usage;
- analysis of video recordings;
- activity sampling.

The most reliable source of information on typical work rate is work records. However, it is important to ensure that the information is compatible with the information required for an evaluation of daily vibration exposure. For example, work records might give very accurate information on the number of completed work items at the end of each day, but where there is more than one operator, or unfinished work items at the end of a shift, this information may not be directly applicable to a vibration exposure evaluation.

Whichever method is used for vibration measurement, the total exposure time per day has to be found. Where the vibration has been averaged over a complete work cycle, the daily exposure time is simply the duration of the work cycle multiplied by the number of cycles per day. If a measurement has been made for a period while the hand is in contact with the vibrating surface, evaluate the total contact time per day.

**Warning!** In general, when operators are asked for information on their typical daily power tool usage, they will normally overestimate, giving an estimate of the period of time for which a power tool is used, including pauses in tool operation (e.g. breaks in tool operation between nuts when operating a nut runner or the time to prepare a new workpiece).

**NOTE** ISO 5349-1 only provides a system for evaluating daily vibration exposure on one working day; it cannot be assumed that the method provided by ISO 5349-1 can be extrapolated to allow the averaging of exposures over periods greater than one day. However, in some situations it may be desirable to obtain an evaluation of exposure based on exposure information obtained over periods greater than one day. For example, in some types of work the amount of time using vibrating power tools changes significantly from one day to the next (e.g. industries such as construction or ship building and repair); it is then difficult, or impossible, to use observation or work records to obtain an indication of typical daily exposure times. Annex B gives examples of methods which have been used for evaluating vibration exposures over periods greater than one day.

## 6 Measurement of vibration magnitude

### 6.1 Measurement equipment

#### 6.1.1 General

Vibration measurement systems generally use accelerometers to detect the motion of the vibrating surface. The vibration signal from the accelerometer can be processed in a number of different ways to achieve a measure of the frequency-weighted acceleration.

Vibration measurements may be made using simple, single-unit vibration meters, featuring built-in frequency weightings and integrating facilities. These systems are designed primarily to evaluate the vibration exposure at the workplace; they are generally sufficient for most situations covered by this part of ISO 5349. However, simple instrumentation may not be able to show errors associated with vibration measurement.

More sophisticated measurement systems are often based around some form of frequency analysis (e.g. one-third-octave or narrow band), they may use digital or analogue data recorders to store time information, they may use computer-based data acquisition and analysis techniques. These systems are more costly and complex to operate than the single-unit systems.

Where there is any doubt about the quality of the acceleration signal (e.g. DC-shift, see 6.2.4) it is useful to have information from frequency analysis. Frequency analysis will also provide information on any dominant frequencies, and harmonics, which may help to identify effective vibration control measures.

At the limits of application of ISO 5349-1 (e.g. repeated single shocks, dominant frequency components exceeding 1250 Hz) any additional information available e.g. from more sophisticated measurement systems may be useful.


Minimum performance requirements (e.g. frequency weighting characteristics, tolerances, dynamic range, sensitivity, linearity and overload capacity) for appropriate measuring and analysing equipment are given in ISO 8041.

#### 6.1.2 Accelerometers

##### 6.1.2.1 General

In general, the choice of accelerometer will be defined by the expected vibration magnitude, the required frequency range, the physical characteristics of the surface being measured and the environment in which they are to be used.

##### 6.1.2.2 Vibration magnitude

Hand-held machines can produce high vibration magnitudes. A pneumatic hammer, for example, can generate a maximum acceleration of 20 000 m/s<sup>2</sup> to 50 000 m/s<sup>2</sup>. However, much of this energy is at frequencies well outside the frequency range used in this part of ISO 5349. Therefore, the accelerometer chosen for the measurement has to be able to operate at these very high vibration magnitudes and yet still respond to the much lower magnitudes in the frequency range from 6,3 Hz to 1 250 Hz (onethird-octave band mid-frequencies). For the use of mechanical filters to suppress vibration at very high frequencies, see Annex C. 

##### 6.1.2.3 Frequency range

Accelerometer selection will also be influenced by the fundamental resonance frequency of the accelerometer, this is a characteristic of the accelerometer (it is sometimes referred to as the "mounted resonance frequency", "natural frequency" or "resonance frequency"). Information on the fundamental resonance frequency will be available from the accelerometer manufacturer. ISO 5348 recommends that the fundamental resonance frequency should be more than five times the maximum frequency of interest (for hand-transmitted vibration, this corresponds to 6250 Hz). For piezoelectric accelerometers, the fundamental resonance frequency should normally be much higher, ideally greater than 30 kHz, to minimize the likelihood of DC-shift distortion (see 6.2.4).

NOTE The fundamental resonance frequency of the accelerometer should not be confused with the resonance frequency of the accelerometer when mounted on a hand-held workpiece or power tool which is a characteristic of the whole accelerometer mounting system. In practice, the resonance of the mounted accelerometer on a hand-held workpiece or power tool will be substantially lower than the fundamental resonance frequency (see 6.1.4).

#### **6.1.2.4 Mass influence**

When accelerometers are attached to a vibrating surface the vibration characteristics of that surface are altered. The lighter the accelerometer(s) the smaller the error introduced (see 6.1.5).

#### **6.1.2.5 Environmental conditions**

When selecting accelerometers, particularly for use in harsh environments, it will be necessary to consider the accelerometer's sensitivity to temperature, humidity or other environmental factors (see ISO 8041).

### **A1 6.1.3 Location of accelerometers**

Vibration measurements in accordance with ISO 5349-1 should be made at or near the surface of the hand (or hands) where the vibration enters the body. Preferably, the accelerometer should be located at the middle of the gripping zone (e.g. halfway along the width of the hand when gripping a machine handle), it is at this location that the most representative evaluation of the vibration entering the hand is obtained. However, it is generally not possible to locate transducers at this point; the transducers will interfere with the normal grip used by the operator.

Measurements directly under the hand are usually only possible using special mounting adaptors (see Annex D). Such adaptors should fit under the hand, or between the fingers. For most practical measurements, the accelerometers are mounted on either side of the hand or on the underside of the machine handle adjacent to the middle of the hand. With adaptors that fit between the fingers, the transducers should be mounted as close as possible to the surface of the machine handle to minimize amplification of rotational vibration components. They should not have any structural resonances that would affect the measured vibration.

It is possible to get differences in vibration measurement across the width of the hand, particularly for hand-held machines with side handles, such as angle grinders, and especially where these handles are flexibly mounted. In these cases, it is recommended that two accelerometer positions be used, located one on each side of the hand; the average of the two vibration measurements is then used to estimate vibration exposure.

For many hand-held machines, specific measurement locations and axes have been defined for the measurement of vibration emission by ISO 22867, ISO 28927, and other International Standards for declaration of vibration emission; these measurement locations are summarized in Annex A as examples of measurement locations. The measurement locations defined in vibration emission standards are designed for a particular type of measurement and are not necessarily suitable for the evaluation of vibration exposure. However, in some circumstances, it may be appropriate to ensure that workplace measurements of vibration are made using locations and axes compatible with those used for emission measurements.

NOTE The ISO 28927 series of standards defines the preferred measurement location as being as close as possible to the hand between the thumb and the index finger, where an operator normally holds the machine. While this measurement position could be suitable for emission testing, it is not invariably suitable for workplace exposure assessment. A1

#### **6.1.4 Attaching accelerometers**

##### **A1 6.1.4.1 General**

The accelerometers should be rigidly attached to the vibrating surface. Annex D gives details of some mounting methods. A method shall be chosen which gives an adequate coupling to the vibrating surface, does not interfere with the operation of the machine, and does not itself affect the vibration characteristics of the vibrating surface. A1

**A1** The mounting method chosen is dependent on the particular measurement situation; each method has its own advantages and disadvantages.

The mounting system should have a flat frequency response across the range of frequencies being measured, i.e. it should not attenuate or amplify and should not have any resonances in this frequency range. The mounting system should be securely attached to the vibrating surface, and should be carefully checked before and after measurement.

The mounting of accelerometers on a machine or hand-held workpiece is necessarily intrusive and can have some effect on how the operator works. The mounting of the transducers should be arranged so that the operator can work as normally as possible. It is important, prior to measurements, to observe how a machine or hand-held workpiece is held, to identify the best location and orientation of the accelerometers. The location (or locations) and orientation of the transducers should be reported.

It is very important to avoid interfering with the machine controls or with the safe operation of the machine. It is often the case on machines, that the best measurement location is where the on-off switch is positioned. Care shall be taken to ensure that the machine controls are not (and will not become) impeded by transducers, mountings or cables.

#### **6.1.4.2 Attaching to surfaces with resilient coatings**

When a machine handle has a soft outer coating, the vibration transmission properties of the coating are dependent on the force with which the mounting system is attached. In such cases, care shall be taken to ensure that the resilient material does not affect the measurement of vibration. If the coating is not thought to be providing reduction in vibration exposure, either

- remove the resilient material from the area beneath the transducers, or
- firmly attach the transducers using a hose clamp or similar device that fully compresses the resilient material.

In most cases, this approach is adequate. However, it does not account for the vibration transmission properties of the resilient coating.

Generally, resilient materials on machine handles are not intended to provide vibration reduction but to provide a good grip surface. Resilient coatings do not usually affect the frequency-weighted vibration magnitude.

If the resilient coating provides some reduction in vibration exposure, for example, if it is a thick layer of resilient material, then attach the transducer to an adaptor (see D.2.4) that is held against the vibrating surface by the normal hand grip of the operator (the adaptor can be held in position using adhesive tape wrapped lightly around the machine handle and adaptor). This type of measurement is difficult, but it could give a better indication of the actual vibration exposure.

NOTE It is possible for poorly selected resilient materials to amplify the vibration at certain frequencies. **A1**

#### **6.1.4.3 Attaching to handles or gripping zones constructed of lightweight, flexible materials**

For power tools with handles or gripping zones constructed of lightweight, flexible materials, e.g. plastic side handle on some sanders and grinders, adhesive may be used to attach low-mass accelerometers to the surface of the material.

#### **6.1.5 Accelerometer mass**

Fixing accelerometers to a vibrating surface will affect the way the surface vibrates. The greater the mass fitted to the surface, the greater the effect. If the total mass of accelerometer, or accelerometers, and mounting system is

small compared to the mass of the power tool, power tool handle or hand-held workpiece it is fitted to (less than 5 %), then the effect can be ignored.

NOTE Practical triaxial measurement systems of less than 30 g have been achieved.

If there is any doubt about the extent of the effect of the transducer's mass then the following test should be used:

- a) Attach the accelerometer(s) to the power tool handle or hand-held workpiece and make a measurement of vibration magnitude.
- b) Repeat the measurement with an additional mass, similar to that of the accelerometer, separately attached to the power tool or hand-held workpiece, positioned next to the accelerometers.
- c) If the magnitude of the vibration from the two measurements is markedly different a lighter accelerometer or mounting system should be used.

### 6.1.6 Triaxial measurement

Triaxial measurement of vibration, using the basicentric coordinate system defined in ISO 5349-1 is preferred. However, there are some situations where triaxial measurement may not be possible or necessary. In such situations ISO 5349-1 requires that an appropriate multiplication factor is applied to a single- or two-axis measurement result to give an estimated vibration total value.

The multiplication factor used should be between 1,0 for highly dominant single-axis tools and 1,7 where the measured axis represents the vibration in all three axes. (A vibration axis is dominant when both non-dominant axis vibration values are each less than 30 % of the dominant axis vibration value.) Where single-axis measurements are to be used, the single axis shall be the dominant axis.

EXAMPLE 1 Where the orientation of a workpiece is continually changing in the hands of the operator (e.g. the pedestal grinding of small components), one single-axis measurement may be sufficient to provide a representative vibration exposure estimate. The vibration total value is given by

$$a_{hv} = \sqrt{a_{hw,x}^2 + a_{hw,y}^2 + a_{hw,z}^2}$$

In this example, the estimated vibration total value is to be calculated from one measured acceleration,  $a_{hw,measured}$ , which is assumed to be representative of the vibration in all three axes of the basicentric coordinate system, i.e.

$$\begin{aligned} a_{hv} &= \sqrt{a_{hw,measured}^2 + a_{hw,measured}^2 + a_{hw,measured}^2} \\ &= \sqrt{3} a_{hw,measured} = 1,73 a_{hw,measured} \end{aligned}$$

Therefore a multiplication factor of 1,73 (rounded to 1,7) should be used to give the estimated vibration total value. The estimated vibration total value will therefore be 1,7 times the measured single-axis vibration value.

EXAMPLE 2 Initial measurements on a road breaker show the vertical axis vibration is dominant and that the vibration in the other axes is each always less than 30 % of the acceleration in the dominant axis,  $a_{hw,dominant}$ . In this case the estimated vibration total value is given by

$$\begin{aligned} a_{hv} &= \sqrt{a_{hw,dominant}^2 + (0,3a_{hw,dominant})^2 + (0,3a_{hw,dominant})^2} \\ &= \sqrt{1 + 2 \times 0,3^2} a_{hw,dominant} = 1,086 a_{hw,dominant} \end{aligned}$$

A multiplication factor of 1,086 (rounded to 1,1) is therefore appropriate. The estimated vibration total value will therefore be 1,1 times the dominant axis vibration value.



### 6.1.7 Simultaneous and sequential measurement

Simultaneous measurement of vibration along three axes is preferred. However, some instruments only allow single-axis measurement, and on very light objects it may only be advisable to measure in one direction at a time (sequential measurement), due to the need to ensure that the total mass of the accelerometers and mounting system is small compared to the mass of the power tool, power tool handle or hand-held workpiece.

Where sequential measurements are made, it is important to ensure that all operating conditions remain the same for the three measurements of x-, y- and z-axis vibration.

### 6.1.8 Frequency weighting

Details on the frequency weighting parameters are given in ISO 5349-1 and ISO 8041.

Frequency weighting can be achieved by

- analogue filters;
- digital filtering of the time signal;
- application of weighting factors to one-third-octave band or narrower-band frequency analysis spectra.

It is important that digital methods, such as digital filtering and Fast Fourier Transform (FFT) analysis, are properly capable of providing accurate analysis over the full frequency range covered by the one-third-octave bands from 6,3 Hz to 1250 Hz. The analyses should provide good resolution at low frequencies, and use a sample rate high enough to obtain accurate information at high frequencies.

It is important that FFT analyses use appropriate time windowing. For continuously operating rotary or rotary percussive tools, the Hanning window function is often suitable. For impactive tools, where the impact rate (impacts per second) is less than 10 times the frequency increment of the narrow-band analysis, then other window functions should be considered. For very low impact rates, e.g. where the impact rate is equal to or less than the frequency increment, then a triggered analysis using an exponential window is recommended.

### 6.1.9 Use of data recorders

Data recording of vibration signals can often be useful, allowing analyses to be performed in a variety of ways on the same data set.

Data recording can be achieved either using analogue or digital recording techniques. In all cases the data recording shall have sufficient dynamic range to ensure that vibration signals over the full frequency range can be reliably recorded. Analogue data recorders often have dynamic ranges from 40 dB to 50 dB which will usually result in the low-frequency components of the acceleration signal being lost in the magnetic tape noise. Digital systems offer better dynamic range characteristics, although care still needs to be taken to ensure best use of the available range.

Some analogue and some digital recording systems use data compression techniques to minimize the space taken by the data; these techniques should be avoided, unless it can be shown that such systems do not lose signal information.

Measurement instrumentation which includes a data recording element, should conform to the requirements of ISO 8041.

### 6.1.10 Measurement range

Most instruments allow the user to select the maximum acceleration magnitude that the instrument can measure. This setting defines the actual measurement range of the instrument. Where the user has to select the input range

of the instrument, the appropriate measurement range can be determined by performing trial measurements. To obtain the best signal-to-noise performance, select the lowest possible measurement range without overloads.

### **6.1.11 Averaging times**

Vibration magnitudes should be averaged over periods of normal use of the power tool, or periods of contact with a hand-held workpiece. An r.m.s. average, using linear averaging, over one or more complete operations or work cycles, should be used.

Exponential averaging should only be used where the vibration instrumentation does not allow linear averaging and the vibration signal is steady enough to allow a reliable evaluation of average vibration value.

## **6.2 Sources of uncertainty in vibration measurement**

### **6.2.1 Cable connector problems**

The most common problem with the measurement of hand-transmitted vibration is ensuring that a reliable connection is maintained with between the accelerometer and the signal cable. In general, care should be taken to ensure that any cable connections are secure and that the cables have not been damaged in any way. In particular at the connection to the accelerometer, great care should be taken to ensure that the cable and connector will not be subjected to undue stresses as the power tool or hand-held workpiece is operated.

Faulty signal connections can show up simply as the loss of signal, in which case it appears that there is no vibration. An intermittent loss of signal connection can show up as DC-offsets, between which the signal appears normal.

Faulty cable screening connections can cause electrical pickup, introducing high levels of mains electricity frequencies. For electrical tools, where the dominant vibration frequency is normally equal to or harmonically related to the mains electricity frequency, it can be difficult to detect this type of fault. For piezoelectric accelerometers, which use signal conditioning amplifiers with high impedance inputs, the loss of connection in the cable earth screening can cause extreme pickup of electrical mains frequencies.

### **6.2.2 Electromagnetic interference**

It is important to prevent electrical, magnetic or electromagnetic fields affecting the vibration measurement. In the case of capacitively and inductively coupled interference signals, the effect of inevitable electromagnetic fields can be reduced by the following means:

- screening cables;
- use of twisted cables;
- earthing the signal cable's screening at one end only, normally at the amplifier end;
- provision of a connection to the transducer balanced to earth (e.g. by using a differential amplifier);
- avoiding signal cables running parallel to power cables;
- provision of electrical insulation between the accelerometer and the vibrating surface.

### **6.2.3 Triboelectric effect**

Instrument cables should not be exposed to high-amplitude vibrational stress because, particularly in systems with a high internal resistance (e.g. piezoelectric accelerometers), electrical signals are produced as a result of deformation. For this reason signal cables should be secured to the vibrating surface, near to the accelerometer (for

example, using adhesive tape). For pneumatically powered hand tools, fixing the cables at regular intervals along the air supply line is generally effective.

#### 6.2.4 DC-shift

Exposing piezoelectric transducers to very high accelerations at high frequencies, for example on percussive tools having no damping system, can cause the generation of DC-shift, where the vibration signal is distorted such that a false additional low-frequency component appears in the vibration signal. The DC-shift distortion occurs in the transducer and is due to excitation of transients which are too large for the transducer, overloading the piezoelectric system mechanically. A means to avoid DC-shift can be a mechanical filter, see annex C.

The presence of DC-shift is first noticeable in the low-frequency region below the percussive frequency; for this reason DC-shift can usually be detected from a frequency analysis of the vibration signal. The distortion can show on a frequency analysis unrealistically high values of low-frequency vibration. Converting the unweighted root-mean-square (r.m.s.) acceleration,  $a$ , to displacement,  $d$ , using  $d = a/(40f^2)$ , (where  $f$  is the centre frequency of the frequency analysis band) will often provide an indication of whether DC-shift has occurred. If the displacement calculated from the acceleration spectrum is clearly larger than the observed motion of the transducer (e.g. greater than twice the observed motion), it is likely that DC-shift has occurred.

If DC-shift has occurred, it is detected by examining the low-frequency components of the vibration signal. However, the DC-shift distortion will affect the entire vibration spectrum. For this reason any measurements showing signs of DC-shift should be disregarded; frequency-weighted vibration values should not be determined from spectra exhibiting DC-shift by removing or modifying low-frequency spectra bands.

### 6.3 Check and verification of the measurement chain



#### 6.3.1 Regular checks of functionality

The whole measurement chain shall be checked, both before and after a sequence of measurements, by using a vibration calibrator (a reference vibration source) which produces known sinusoidal acceleration at a known frequency.

NOTE In practice, the sensitivity of accelerometers rarely drifts during measurements, however, they may suffer mechanical failure. Therefore changes in apparent sensitivity should be noted and measurements discarded if necessary.

#### 6.3.2 Routine verification of the measurement system

The characteristics of the measurement system should be verified on a regular basis (e.g. every 2 years). These verification checks should ensure that the instrumentation is functioning within the tolerances defined in ISO 8041.

 *Text deleted* 

In addition to regular verification, the measurement system should be verified after rough handling of any important part of the measurement system. The results of these verification checks shall be recorded.

## 7 Uncertainty of evaluation of daily vibration exposure

### 7.1 Acceleration measurement uncertainty

When measuring vibration transmitted to workers the uncertainty will be affected by factors related to individual measurements, such as

- instrumentation accuracy;
- calibration;

- electrical interference;
- mounting of accelerometers;
- mass of accelerometers;
- location of accelerometers;
- changes from the normal operation of the power tool and changes to hand posture and applied forces brought about by the measurement process (i.e. mounting of accelerometers and associated cables);
- changes in the operator's method of working, as a response to being the subject of the measurement.

In addition uncertainty of the overall evaluation of vibration exposure will be affected by changes which occur in the course of any working day, such as

- changes in the condition of power tool and inserted tool (e.g. changing the wheel of a grinder may change the vibration transmitted to the operator dramatically);
- changes in posture and applied forces;
- changes in the characteristics of the materials being processed.

NOTE 1 The uncertainty associated with instrumentation and calibration, electrical interference and mounting and mass of accelerometers will usually be small compared with the uncertainties which arise from selection of measurement location and variability in the work operation.

NOTE 2 When investigating the history of exposure of individuals it is desirable, if possible, to measure the vibration of machines and inserted tools of different generations and different states of maintenance.

NOTE 3 When the purpose of the measurement is evaluation of vibration exposure associated with a specific task, the differences between operators (variation in expertise, stature, etc.) may also be a source of uncertainty (see 7.3).

## **7.2 Exposure time measurement uncertainty**

The uncertainty of the estimation of exposure time is affected by the uncertainty of

- measurements of the durations of exposure;
- estimates of the number of work cycles per day;
- exposure time estimates supplied by the operators (see annex B), this may come from misinterpretation of the question (confusion between usage of the power tool and real exposure to vibration), as well as poor estimates of the durations for which exposure to vibration occurs (see 5.5).

## **7.3 Evaluation of uncertainties**

The sources of uncertainty depend on the operation measured. The experimenter should determine the main sources (e.g. wheel unbalance in the case of grinders) and multiple measurements should be made in order to determine the extent of the uncertainty and to calculate the standard deviation regarding the dominant sources of uncertainty (e.g. it may be useful to measure a grinding machine with wheels of different unbalance).

If the purpose of the measurement is not to evaluate the vibration exposure of a specific worker, but to evaluate the exposure of a specific task, the evaluation of vibration exposure should, if possible, be based on measurements using at least three different workers. The reported result shall be the arithmetic mean of the measurements, the standard deviation should also be recorded.

## 8 Calculation of the daily vibration exposure

In many cases a worker's daily vibration exposure comes from a number of operations. For each operation  $i$ , the vibration total value,  $a_{hvi}$ , and the exposure time to that source,  $T_i$ , shall be measured. The daily vibration exposure  $A(8)$ , in  $m/s^2$ , shall be obtained from

$$A(8) = \sqrt{\frac{1}{T_0} \sum_{i=1}^n a_{hvi}^2 T_i} \quad (1)$$

where

$T_0$  is the reference duration of 8 h (28800 s)

$n$  is the number of operations.

In order to facilitate comparison between different operations and to evaluate the individual contribution of a particular operation to the daily vibration exposure  $A(8)$ , it may be useful to calculate the partial vibration exposure for the individual operation,  $A_i(8)$ , using

$$A_i(8) = a_{hvi} \sqrt{\frac{T_i}{T_0}} \quad (2)$$

The daily vibration exposure is then given by

$$A(8) = \sqrt{\sum_{i=1}^n A_i^2(8)} \quad (3)$$

$A(8)$  should be evaluated separately for both hands of the operator.

The uncertainties associated with the evaluation of  $A(8)$  are often high (e.g. 20 % to 40 %). Therefore, values of  $A(8)$  should not normally be presented with more than two significant figures.

Practical applications of the calculation of the daily vibration exposure are given in annex E.

## 9 Information to be reported

The evaluation report shall refer to this part of ISO 5349 and provide, dependent on the situation investigated, the following information:

- a) General information:
  - company/customer;
  - purpose of the measurements (e.g. evaluation of vibration exposure of individual workers, worker groups, evaluation of control measures, epidemiological study);
  - date of evaluation;
  - subject or subjects of the individual exposure evaluation;
  - person carrying out the measurements and evaluation.
- b) Environmental conditions at the workplace:
  - location of measurements (e.g. indoor, outdoor, factory area);
  - temperature;

- humidity;
  - noise.
- c) Information used to select the operations measured (see 5.2).
- d) Daily work patterns for each operation evaluated:
- description of operations measured;
  - machines and inserted tools used;
  - materials or workpieces used;
  - patterns of exposure (e.g. working hours, break periods);
  - information used to determine daily exposure times (e.g. work rate or numbers of work cycles or components per day, durations of exposure per cycle or hand-held workpiece).
- e) Details of vibration sources:
- technical description of the power tool or machine;
  - type or model number;
  - age and maintenance condition of the power tool or machine;
  - weight of the hand-held power tool or hand-held workpiece;
  - vibration control measures on the machine or power tool, if any;
  - type of hand grip used;
  - automatic control systems of the machine (e.g. torque control on nut runners);
  - power of the machine;
  - rotational frequency or percussive speed;
  - models and types of inserted tools;
  - any additional information (e.g. unbalance of inserted tools).
- f) Instrumentation:
- instrumentation detail;
  - calibration traceability;
  - date of most recent verification test;
  - results of functionality check;
  - results of any interference tests.
- g) Acceleration measurement conditions:
- accelerometer locations and orientations (including a sketch and dimensions);
  - methods of attaching transducers;
  - mass of the transducers and mount;

- operating conditions;
  - arm posture and hand positions (including whether the operator is left- or right-handed);
  - any additional information (e.g. data on feed and grip forces).
- h) Measurement results:
- x-, y- and z-axis frequency-weighted hand-transmitted vibration values ( $a_{hwix}$ ,  $a_{hwiy}$  and  $a_{hwiz}$ ), possibly for each operation;
  - measurement durations;
  - if frequency analysis is available, the unweighted frequency spectra;
  - if single- or two-axis measurements were used, the multiplying factors to give vibration total value estimates (including justification for using single- or two-axis measurements and justification for the multiplying factors used).
- i) Daily vibration exposure evaluation results:
- vibration total values,  $a_{hvi}$ , for each operation;
  - duration of vibration exposure for each operation,  $T_i$ ;
  - partial vibration exposures for each operation,  $A_i(8)$ , if available;
  - daily vibration exposure,  $A(8)$ ;
  - evaluation of the uncertainty of daily vibration exposure results.

## **A1** Annex A (informative)

### **Examples of measurement locations**

#### **A.1 Introduction**

It is not always practical to make measurements at the surface of the hand(s) where the vibration enters the body in the middle of the gripping zones as described in 6.1.3; for example, on machines with a closed or open bow grip or a pistol grip, the location of the trigger can make measurement halfway along the handle impossible. In practice, the measurement location usually has to be to one side of the hand. The location of machine controls and hand guards can also affect where it is possible to attach accelerometers. [Figure A.1](#) shows examples of measurement locations for some common machines, controls, and work tasks.

#### **A.2 Measurement locations used in vibration type test standards**

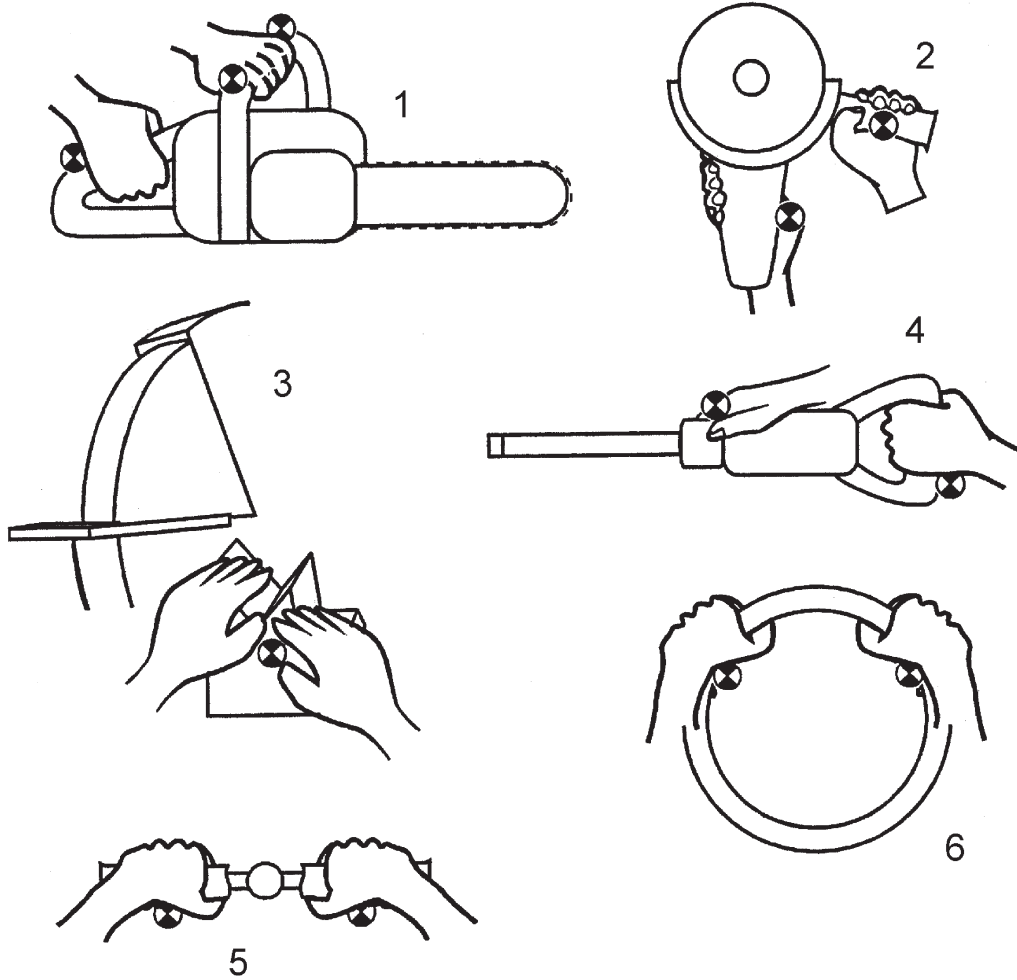
[Table A.1](#) lists, as examples, the measurement locations specified in ISO 22867 and in the ISO 28927 series. These International Standards specify laboratory methods for measuring the vibration at the handles of different hand-held machines for the purpose of determining vibration emission values.

ISO 28927 series requires that measurements be made at the gripping zones, where the operator normally holds the machine and applies the feed force. These International Standards define a prescribed transducer location for both hands, to be as close as possible to the hand between the thumb and index finger. A secondary location is also defined, as being on the side of, and as close as possible to, the inner end of the handle where the prescribed location is found. The prescribed and secondary transducer positions are identified as positions “1” and “2” in [Table A.1](#). The secondary position is used when the prescribed location is not accessible or when use of that location would prevent correct operation of the machine.


The locations shown in [Table A.1](#) are suitable for emission testing, but might not be appropriate for the measurement of workplace exposure. In addition, the orientation of the axes X, Y, Z, shown in the pictures also cannot match the basicentric coordinate system discussed in Part 1 of this International Standard. The objectives of an exposure measurement are very different to those of a type test. For evaluation of vibration exposure, the location of the accelerometers shall be based on where the hand actually holds the machine, rather than where the machine is held during a type test. The principal requirement of the vibration type test standards is that measurements are made in the main gripping zone where the operator normally holds the machine and applies the feed force. <sup>(A1)</sup>



A1



**Key**

- 1 chainsaw
- 2 angle grinder
- 3 pedestal grinding
- 4 chipping hammer
- 5 hand-guided machine
- 6 steering wheel
-  measurement location

**Figure A.1 — Examples of practical measurement locations for some common machines, controls and work tasks** A1

Table A.1 — Examples of accelerometer locations on machines used in ISO 22867 and ISO 28927 for vibration type testing

| ISO standard   | Type of machine  | Mounting locations                   | Brush-cutter or grass-trimmer with bicycle-type handles        | Brush-cutter or grass-trimmer with loop-type handle        | Application to work-place measurement  |
|----------------|--|--------------------------------------|--|--|--|
| ISO 22867:2011 | Forestry and gardening machinery with internal combustion engine | <p>Chainsaw</p> <p>Hedge trimmer</p> | <p>Brush-cutter or grass-trimmer with bicycle-type handles</p> | <p>Brush-cutter or grass-trimmer with loop-type handle</p> | <p>When a chainsaw is used on its side, the measurement position on the top of the front handle shown here is not suitable. Workplace measurements should be made as close as possible to the centre of the gripping zone at the time of use of the machine. When the saw is used on its side, the hand position is moved around to the side of front handle. The transducer position must also be moved to follow this hand movement.</p> |

A.1

Table A.1 (continued)

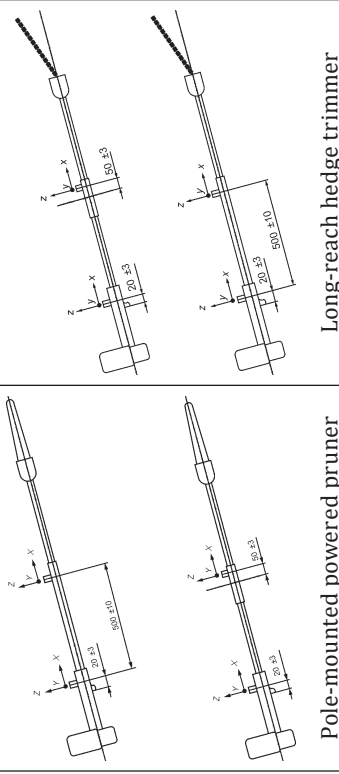
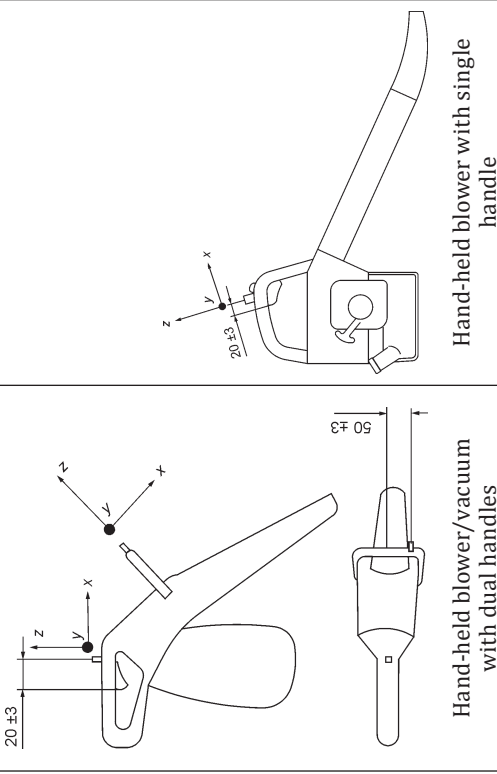
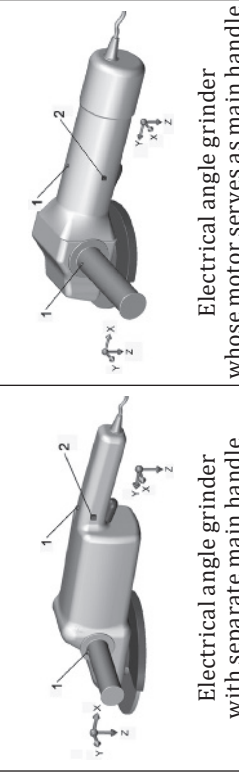
| ISO standard               | Type of machine  | Mounting locations  | Application to work-place measurement  |
|----------------------------|--|---|--|
| ISO 22867:2011 (continued) | Forestry and gardening machinery with internal combustion engine |  <p>Pole-mounted powered pruner</p> <p>Long-reach hedge trimmer</p>                               |  |
| ISO 28927-1:2009           | Angle and vertical grinders                                      |  <p>Hand-held blower/vacuum with dual handles</p> <p>Hand-held blower with single handle</p>     |  |
|                            |  |  <p>Backpack blower/vacuum</p> <p>Pneumatic angle grinder whose motor serves as main handle</p> | <p>For workplace measurements, use of the prescribed location on the side handle (support handle) is likely to underestimate real workplace exposures.</p> <p>Electrical angle grinder whose motor serves as main handle</p> |

Table A.1 (continued)

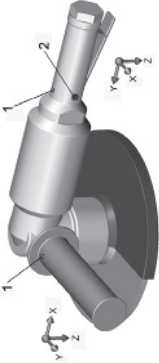
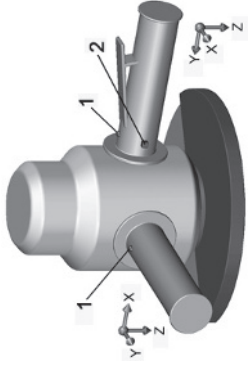
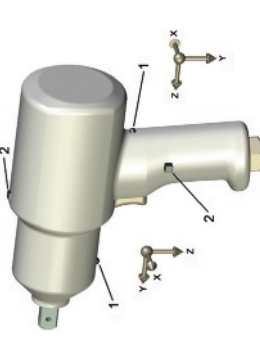


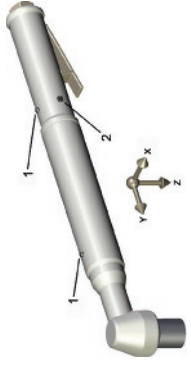
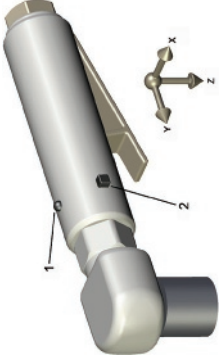
| ISO standard                 | Type of machine                       | Mounting locations  | Application to workplace measurement   |
|------------------------------|---------------------------------------|---|--|
| ISO 28927-1:2009 (continued) | Angle and vertical grinders           |  <p>Pneumatic vertical grinder with separate main handle</p>                       |  <p>Pneumatic vertical grinder</p>  |
| ISO 28927-2:2009             | Wrenches, nutrunners and screwdrivers |  <p>Impact wrench/impulse nutrunner with pistol grip</p>                           |  <p>Impact wrench/impulse nutrunner with bow grip and bow shaped support handle</p> |
|                              |                                       |  <p>Impact wrench/impulse nutrunner with bow grip and straight support handle</p> |  <p>Angle nutrunner</p>   |
|                              |                                       |  <p>Ratchet wrench</p>   |  |

Table A.1 (continued)

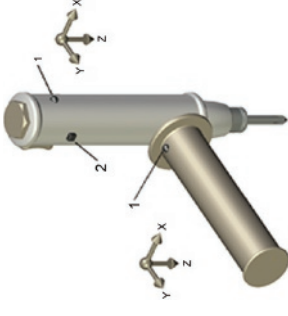

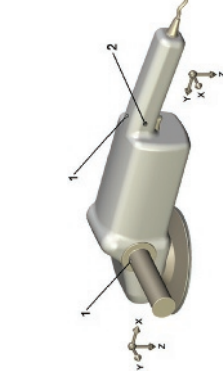
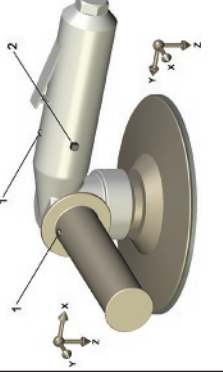
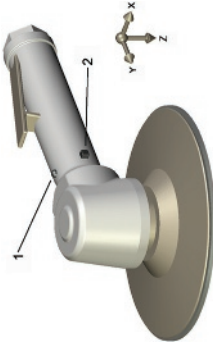
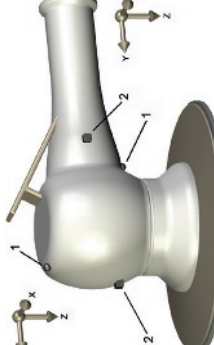
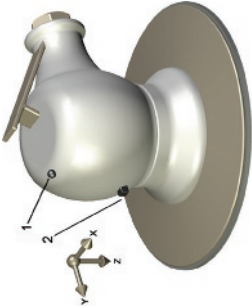
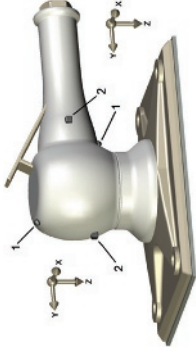
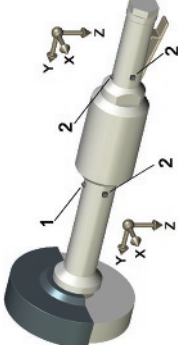
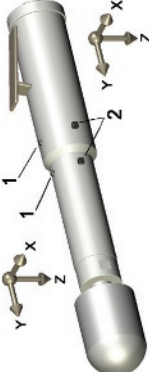
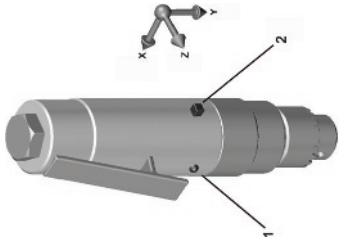

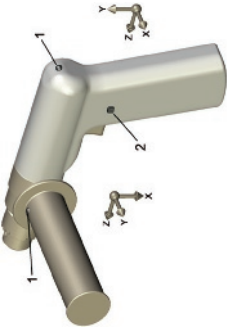


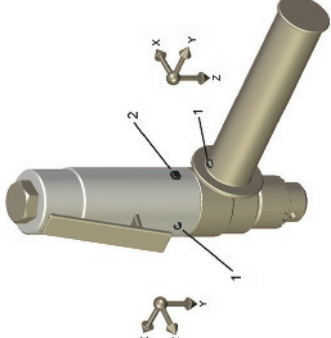
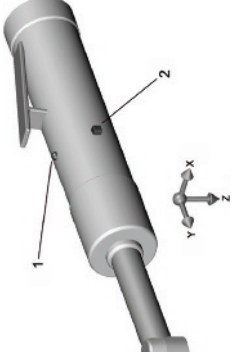
| ISO standard                    | Type of machine  | Mounting locations  |   | Application to workplace measurement  |
|---------------------------------|--|---|---|---|
| ISO 28927-2:2009<br>(continued) | Wrenches, nutrunners and screwdrivers                    |  <p data-bbox="710 1288 774 1675">Straight screwdriver with support handle</p>                   |  <p data-bbox="742 907 774 1288">Straight screwdriver</p>  | For workplace measurements, use of the prescribed location on the side handle is likely to underestimate real workplace exposures. Workplace measurements should be made at the centre of the gripping zone of the side handle. |
| ISO 28927-3:2009                | Polishers and rotary, orbital and random orbital sanders |  <p data-bbox="1396 1288 1460 1675">Angle rotary sander/polisher with separate main handle</p> |  <p data-bbox="1380 907 1460 1288">Angle rotary sander/polisher where the motor serves as main handle</p> | For workplace measurements, use of the prescribed locations on the side handles or the trigger handle of the vertical sander/polisher is likely to underestimate real workplace exposures.                                      |

Table A.1 (continued)

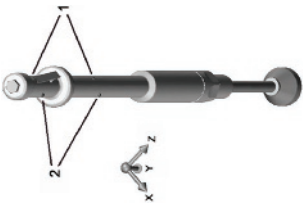

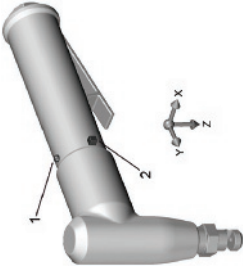


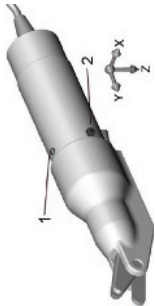
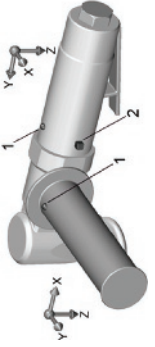
| ISO standard                 | Type of machine  | Angle sander/polisher intended for one-handed operation                              | Random orbital sander   | Palm sander  | Orbital sander with rectangular pad   | Application to workplace measurement  |
|------------------------------|--|--|---|--|---|---|
| ISO 28927-3:2009 (continued) | Polishers and rotary, orbital and random orbital sanders |   |  |  |  | Workplace measurements should be made at the centre of the gripping zone of the side handle.  |
| ISO 28927-4:2010             | Straight grinders  |  |  |  |   | For workplace measurements, use of the prescribed location on the front hand-position is likely to underestimate real workplace exposures.<br><br>Workplace measurements should be made at the centre of the gripping zone. |

A1

Table A.1 (continued)

| ISO standard     | Type of machine          | Mounting locations   | Application to workplace measurement  |
|------------------|--------------------------|--|---|
| ISO 28927-5:2009 | Drills and impact drills |  <p>Straight drill</p>                            |  <p>Drill with pistol grip</p> |
|                  |                          |  <p>Drill with pistol grip and second handle</p> |  <p>Impact drill</p>          |
|                  |                          |  <p>Impact drill with second handle</p>         |   |
|                  |                          |  <p>Straight drill with support handle</p>         |   |
|                  |                          |  <p>Angle drill</p>                               |   |
|                  |                          |  |   |

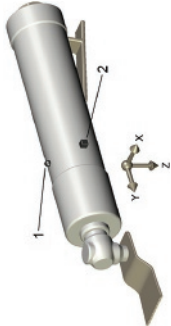
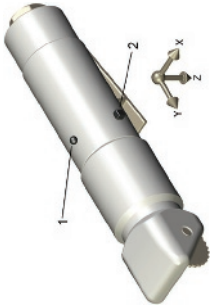

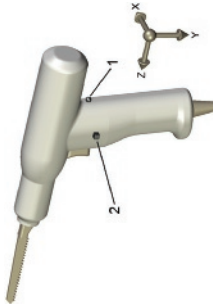
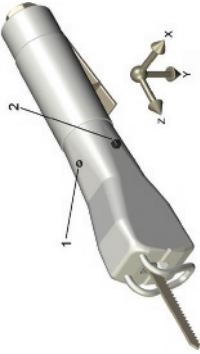
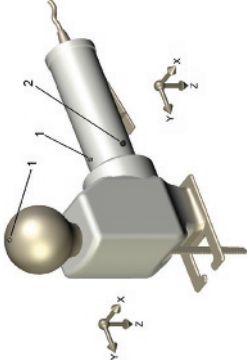


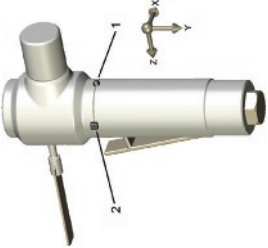
**Table A.1 (continued)**

| ISO standard     | Type of machine     | Mounting locations  |  | Application to workplace measurement   |  |
|------------------|---------------------|---|--|--|--|
| ISO 28927-6:2009 | Rammers             |  <p>Rammer for use on floors</p>     |  <p>Rammer for use on benches</p>                        |  |  |
| ISO 28927-7:2009 | Nibblers and shears |  <p>Nibbler</p>                      |  <p>Shears with pistol grip</p>                          |  <p>Shears for circular cutting</p> | <p>For workplace measurements, use of the prescribed location on the side handle is likely to underestimate real workplace exposures. Workplace measurements should be made at the centre of the gripping zone of the side handle.</p> |
|                  |                     |  <p>Shears with straight handle</p> |  <p>Shears for circular cutting with support handle</p> |  |  |

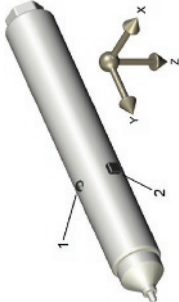
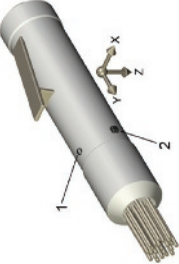


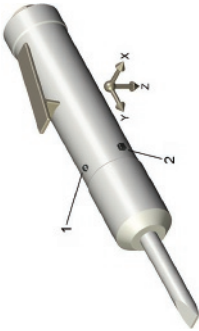
A1



**Table A.1 (continued)**

| ISO standard   | Type of machine  | Mounting locations  | Application to workplace measurement   |  |
|--|--|---|--|--|
| ISO 28927-8:2009<br><br>Saws, polishing and filing machines with reciprocating action and saws with oscillating or rotating action |  <p>Straight oscillating saw</p>            |  <p>Small circular saw</p>          |  <p>Reciprocating saw with bow handle</p>               |  |
|  |  <p>Reciprocating saw with pistol grip</p> |  <p>Straight reciprocating saw</p> |  <p>Jig saw</p>  | <p>For workplace measurements, use of the prescribed location on the side handle is likely to underestimate real workplace exposures. Workplace measurements should be made at the centre of the gripping zone of the side handle.</p> |
|  |  <p>Straight reciprocating file</p>       |  <p>Angle reciprocating file</p>  |  <p>Angle reciprocating file — Alternative design</p> | <p>For workplace measurements, use of the prescribed location on the side handle is likely to underestimate real workplace exposures. Workplace measurements should be made at the centre of the gripping zone of the side handle.</p> |

**Table A.1 (continued)**

| ISO standard     | Type of machine                    | Mounting locations   |   | Application to work-place measurement  |
|------------------|------------------------------------|--|---|--|
| ISO 28927-9:2009 | Scaling hammers and needle scalers |  <p>Engraving pen</p> |  <p>Straight needle scaler</p>                |  |
|                  | Scaling hammer with pistol grip    |                       |  <p>Angle-head scaling hammer (scab-bler)</p> |  <p>Straight scaling hammer</p> |

A1

## Annex B (informative)

### Evaluation of vibration exposure over periods greater than one day

#### B.1 Introduction

ISO 5349-1 only provides a system for evaluating daily vibration exposure on one working day. The system for calculating daily vibration exposure defined in ISO 5349-1 is not intended for use over periods greater than one day and the guidance given in annex C of ISO 5349-1:2001 is based on work situations where daily vibration exposure is unvarying.

For some work situations, it may be desirable to obtain an evaluation of exposure based on exposure information obtained over periods greater than one day. In some types of work the amount of time using vibrating power tools changes significantly from one day to the next (e.g. industries such as construction or ship building and repair); it is then difficult, or impossible, to use observation or work records of a single day's work to obtain an indication of typical daily exposure times. In other situations values representing total vibration exposure over extended periods (e.g. lifetime exposure) may be useful.

This annex gives examples of methods which have been used for evaluating vibration exposures over periods greater than one day. Where vibration exposure is evaluated over periods greater than one day, the results shall not be used to determine risks to health. Where such evaluations are carried out, evaluation of actual daily vibration exposure should also be made and reported.

#### B.2 Estimating typical daily vibration exposure when exposure varies from day to day

In cases where a worker is exposed to vibration on a daily basis but the vibration exposure will change from one day to the next (e.g. in construction projects where one work task takes more than one day), it may be useful to compare typical vibration exposures, for example when developing vibration control plans. In this case the typical daily vibration exposure estimate,  $A_{\text{typical}}(8)$ , is given by

$$A_{\text{typical}}(8) = \sqrt{\frac{1}{N} \sum_{d=1}^N A_d^2(8)} \quad (\text{B.1})$$

where

$A_d(8)$  is the daily vibration exposure on day  $d$

$N$  is the number of working days over which the estimation is to be determined.

If the vibration magnitude is the same on each working day (i.e. the same power tool is used each day) but the time for which the power tool is used changes from day to day, then the equation becomes:

$$A_{\text{typical}}(8) = a_{\text{hv}} \sqrt{\frac{\bar{t}_d}{T_0}} \quad (\text{B.2})$$

where

$a_{\text{hv}}$  is the vibration total value for the operation

$T_0$  is the reference duration of 8 h (28800 s)

$\bar{t}_d$  is the average daily exposure duration.

NOTE This estimate assumes that the time dependency for the calculation of  $A(8)$  is valid over periods greater than one day.

### **B.3 Procedure when vibration exposure does not occur on every working day**

Vibration exposure may occur on an irregular basis, such as operations which take place on one day but not on others (e.g. cupola cleaning in foundries). In such cases for those days for which a vibration exposure existed, the daily vibration exposure and the number of work days per week, per month or per year, for which this vibration exposure occurred, should be reported.

## Annex C (informative)

### Mechanical filters

#### C.1 General

The risk of DC-shift distortion in piezoelectric accelerometers (see 6.2.4) can be reduced by the careful selection of accelerometers (see 6.1.2). However, when measuring on percussive or roto-percussive power tools, or in case of doubt, a mechanical filter fitted between the transducer and the vibration source is recommended. Such a filter reduces the very high frequency content of the transients, and prevents the mechanical overloading of the piezoelectric system. The mechanical filter acts as a low-pass filter attenuating the frequencies which cause DC-shift, while vibration in the frequency range of interest is not influenced.

NOTE The DC-shift is a distortion brought about by the charge-coupling of piezoelectric accelerometers. Other accelerometer types, such as piezoresistive accelerometers, are not affected by DC-shift. Therefore, the use of mechanical filters to prevent DC-shift is only necessary when using piezoelectric accelerometers.

Mechanical filters may also be useful in reducing the influence of unwanted high-frequency vibration on the accelerometer, preventing signal-processing overloads caused by high-frequency acceleration signals or allowing more sensitive accelerometers to be used than would be possible without the mechanical filter.

#### C.2 Selection

A mechanical filter shall be suitable for the accelerometer. The cut-off frequency of the mechanical filter is influenced by the mass of the accelerometer. Mechanical filters are available from some transducer manufacturers, or can be constructed using suitable resilient materials. For lightweight transducers (around 2 g), a simple thin layer of resilient material below the transducer mount is likely to be sufficient.

The mechanical filter should not alter the frequency response characteristics of the measurement system in the frequency range of interest, i.e. there should be no amplification or attenuation of vibration signals below 1250 Hz, and the additional mass of the mechanical filter should not alter the vibration characteristics of the vibrating surface. Comparative measurements with and without the mechanical filter on a power tool which does not produce DC-shift can be used to assess the frequency response of a mechanical filter.

The system consisting of mechanical filter and transducer shall be as compact as possible so as to ensure that the centre of the transducer is as close as possible to the vibrating surface.

It is not advisable to mount a three-directional transducer system onto one mechanical filter.

#### C.3 Use on axes perpendicular to the percussive axis

A mechanical filter is generally only needed to avoid DC-shift in measurements of acceleration along the dominant axis of vibration, i.e. along the percussive axis of percussive or impact power tools.

Where DC-shift is a problem along a non-dominant axis of a percussive power tool, mechanical filters should be used with caution; in such cases mechanical filters may increase the apparent transverse sensitivity to vibration by allowing excessive rotational motion of the accelerometer. Accelerometers should be fitted with their direction of minimum transverse sensitivity aligned to the percussive axis to minimize any effect due to rotational motion.

## Annex D (informative)

### Guidance on mounting accelerometers

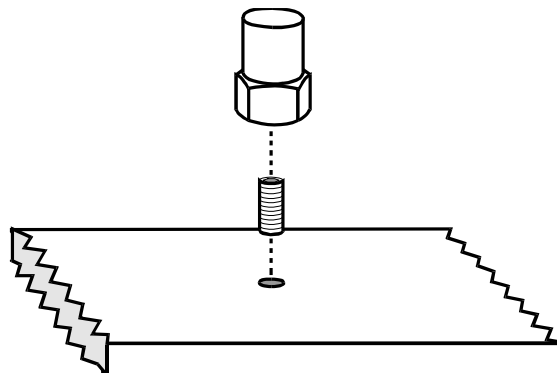
#### D.1 Introduction

To fix accelerometers to vibrating surfaces different mounting methods have been developed. In Figures D.1 to D.4 some mounting methods are shown, together with the circumstances in which they can be applied and the advantages and disadvantages associated with them. These examples were selected because of their flat frequency response in the frequency range of interest. For further guidance, see ISO 5348.

#### D.2 Mounting methods

##### D.2.1 Stud mounting (screwed)

A threaded hole is drilled into the vibrating surface. The accelerometer (or accelerometers) is attached directly to the hole using a standard mounting stud. Adhesive may also be used to prevent the stud from shaking loose.

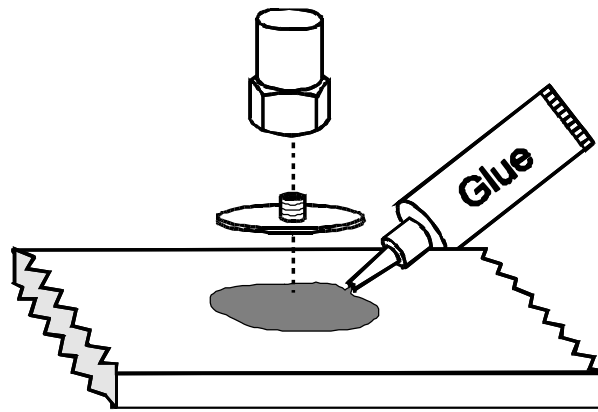


| Advantages   | Disadvantages   |
|--|---|
| Good frequency response<br>Not affected by surface temperature | Contact surface shall be flat<br>Cannot be used on hand tools, where it might affect the electrical or pneumatic safety of the power tool |

**Figure D.1 – Stud mounting (screwed)**

##### D.2.2 Mounting by glue or cement

Glue or epoxy resin type cement is used to attach the accelerometer to the vibrating surface. Usually a (disposable) glue mounting stud is used to avoid using glue directly on the accelerometer. The use of soft setting glues or wax is not recommended because of the poor coupling through such adhesives, which often result in a poor frequency response.

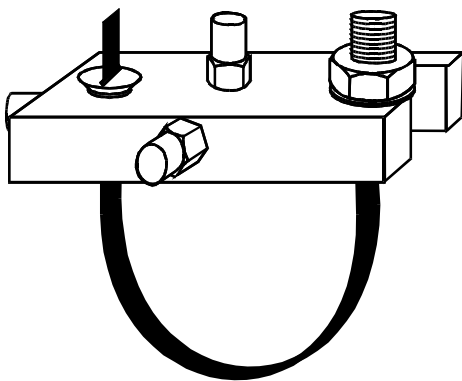


|                        | Advantages   | Disadvantages                           |
|------------------------|--|---|
| Glue                   | Good frequency response                            | Contact surface shall be flat and clean |
| Cement/<br>epoxy resin | Good frequency response<br>Fits to uneven surfaces | Contact surface shall be clean          |

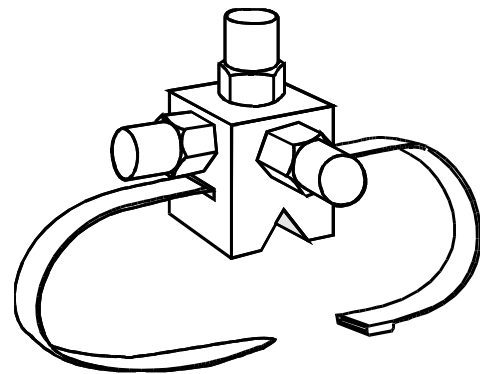
Figure D.2 – Mounting by glue or cement

### D.2.3 Clamp connections

The accelerometers are attached to a lightweight mounting block. The block is held against the vibrating surface by a flexible strap. Metal or nylon straps have been successfully used. Nylon cable ties should be of a type which can be fastened tightly (ratchet type reusable cable ties are not suitable). Care should be taken to ensure that any resonance frequencies of the mounting assembly are high enough above the upper limit of the measurement frequency range.



a) Metal "U" clamp (with metal strap)



b) With nylon strap or metal hose-clip

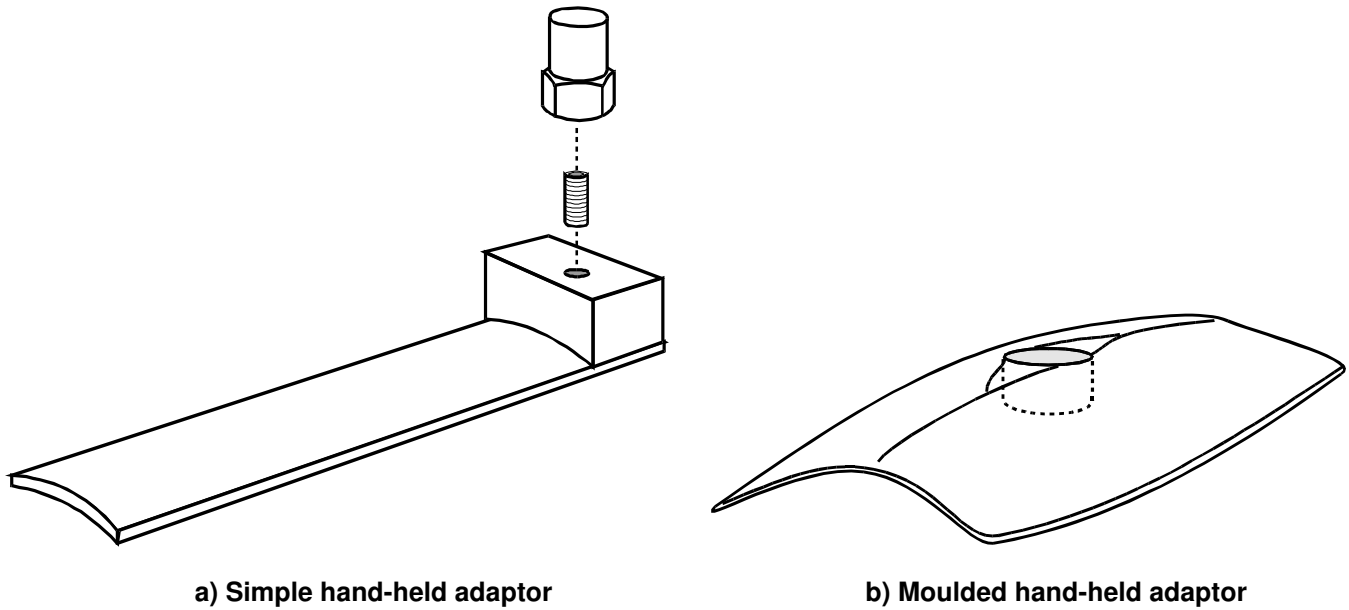
|  | Advantages  | Disadvantages  |
|--|---|--|
| Metal "U" clamp<br>(with metal strap)  | Suitable for triaxial measurements  | Bulky and heavy  |
| With nylon strap or<br>metal hose-clip | Rapid mounting<br>Suitable for triaxial measurements<br>Light<br>No sharp edges | Mainly limited to measurement on<br>power tool handles |

Figure D.3 – Clamp connections

**D.2.4 Hand-held adaptors**

Fixed mounting systems may not always be feasible, particularly where the operator grips a surface covered by a resilient material. Hand-held mounting systems rely in the operator's grip force to hold the mounting system in place; although, it often is advisable to lightly hold the adaptor in position on the vibrating surface using elastic adhesive tape.

For difficult surfaces, individually moulded adaptors may be suitable. These use a modelling material to fabricate an elliptical disc which is moulded to the work surface on its lower face, and to the palm of the hand on its upper face, with a space left for the accelerometer. Once hardened, an accelerometer can be fitted into the adaptor, which then fits comfortably between the work surface and the hand.



|                              | <b>Advantages</b>   | <b>Disadvantages</b>   |
|------------------------------|---|--|
| Simple hand-held adaptor     | Can be used in cases where a fixed coupling is inapplicable, e.g. on soft or resilient materials  | Only suitable for fixed hand position and where the handle is always being held<br>Frequency response depends of surface material<br>The presence of the adaptor may change the operation of the power tool and the resulting vibration magnitude<br>Additional fixing (e.g. adhesive) is required for transverse vibration measurements |
| Individually moulded adaptor | Can be used in cases where a fixed coupling is inapplicable, e.g. on soft or resilient materials<br>Little influence of the adaptor on the operation of the power tool<br>Fair frequency response | Preparation of the adaptor is a laborious, time consuming procedure<br>Difficult to use for triaxial measurements  |

**Figure D.4 – Hand-held adaptors**



## Annex E (informative)

### Examples of the calculation of daily vibration exposure

#### E.1 Introduction

This annex gives some examples of the organization and calculation of 8-h energy-equivalent vibration total value (daily vibration exposure),  $A(8)$ , according to clause 8. The examples are related to the measurement procedures specified in 5.3.

In all the worked examples given in this annex:

- acceleration magnitudes are assumed to be averaged vibration total values;
- only one vibration exposure figure is calculated, normally separate evaluations are needed for the left and right hands;
- little variation in vibration magnitude is shown within periods of exposure, normally larger variations would be common, and some averaging of sample vibration measurements would be required.

#### E.2 Examples of the use of single power tools

##### E.2.1 Long-term measurement of continuous tool operation

This is the simplest measurement situation: The power tool is operated continuously for long periods and the hand is always in contact with the power tool or hand-held workpiece during use. Examples of this type of operation are levelling a large area using a vibrating plate tamper, floor polishing and ride-on lawn mowers.

In this case

- the measurements of vibration magnitude can be made over long periods, which will give good, representative values;
- the exposure time is the time for which the power tool is used.

##### a) Advantages

The vibration magnitude may be applied easily to vibration exposure evaluations in other situations, where the exposure times may be different.

##### b) Disadvantages

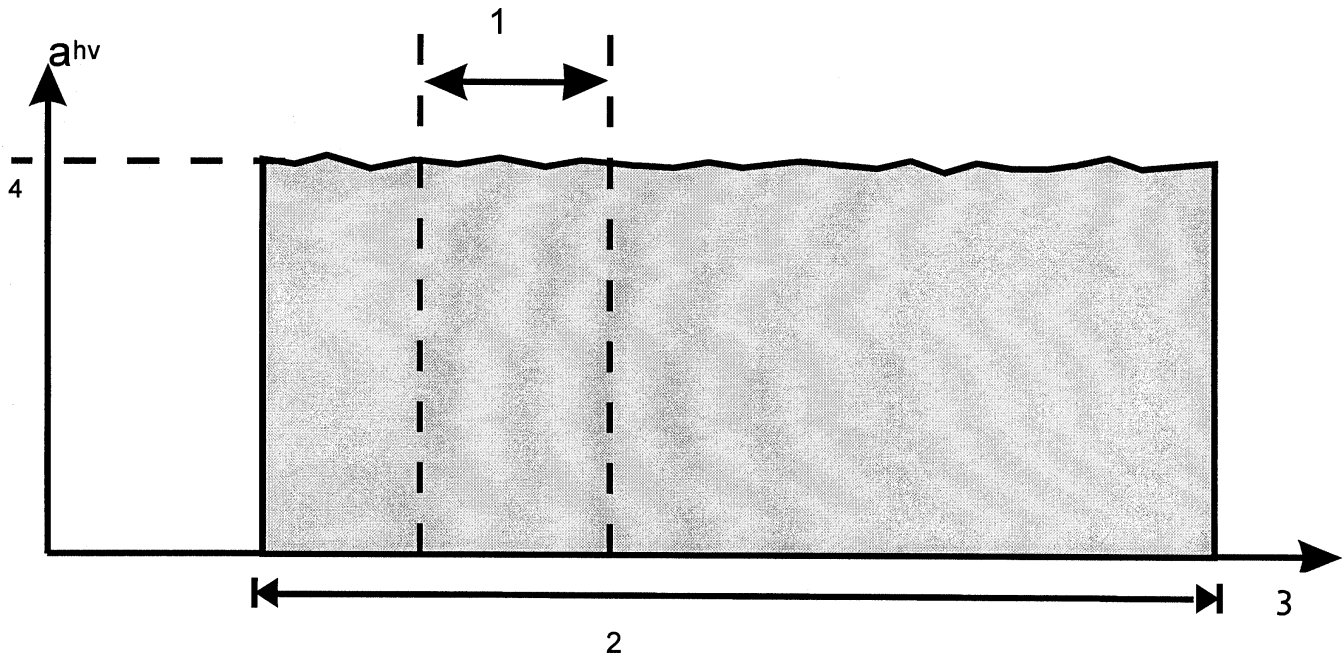
There are no real disadvantages to this type of measurement, but, in practice, there are not many cases where it is possible.

**EXAMPLE** During a working day, a vibrating plate tamper is used for a total of 2,5 h, no other vibrating tools are used. The vibration exposure pattern is similar to that shown in Figure E.1. The arithmetic average of three measurements of the vibration on the power tool handles indicates that the vibration total value,  $a_{hv}$ , is 7,4 m/s<sup>2</sup>.

The daily vibration exposure,  $A(8)$ , is given by equation (1) which for single exposure is:

$$A(8) = a_{hv} \sqrt{\frac{T}{T_0}} \tag{E.1}$$

$$= 7,4 \sqrt{\frac{2,5}{8}} = 4,1 \text{ m/s}^2$$



- Key**
- 1 Measurement duration
  - 2 Operating time (= exposure time)
  - 3 Time
  - 4  $a_{hv,measured}$

Figure E.1 – Long-term measurement of continuous exposures

### E.2.2 Long-term measurement of intermittent tool operation

For many power tools, the hand is always in contact with the power tool or hand-held workpiece during use, but the power tool is not operated continuously, there are short breaks in operation when it is used. Examples of this type of operation include the use of grinders, chain saws and scaling hammers.

If the power tool is being operated for most of the period of use, one option is:

- to carry out a long-term measurement of vibration magnitude over a representative period of use, in which case
- the exposure time is the time for which the power tool is used during the working day.

#### a) Advantages

The vibration magnitude is representative of the actual task, including periods when the machine is building up to operating speed and running back down to idling or off (periods which may not be included in other methods).

b) Disadvantages

The vibration magnitude value obtained in this way is dependent on proportion of time the power tool is operating in the user's hand. This vibration magnitude information is, therefore, not easily transferable to other situations where the same power tool is being used.

The measurement may include shocks (such as those from dropping the power tool onto a work bench) which are not part of the vibration exposure.

**EXAMPLE** A grinder is used to grind disk-shaped castings. Work records show that an average of 100 castings are worked on per day. For each casting the operator grinds around the circumference of the casting and then works on the upper and lower faces. The vibration exposure pattern is similar to that shown in Figure E.2. The average vibration measured over the period of one cycle is 3,6 m/s<sup>2</sup>.

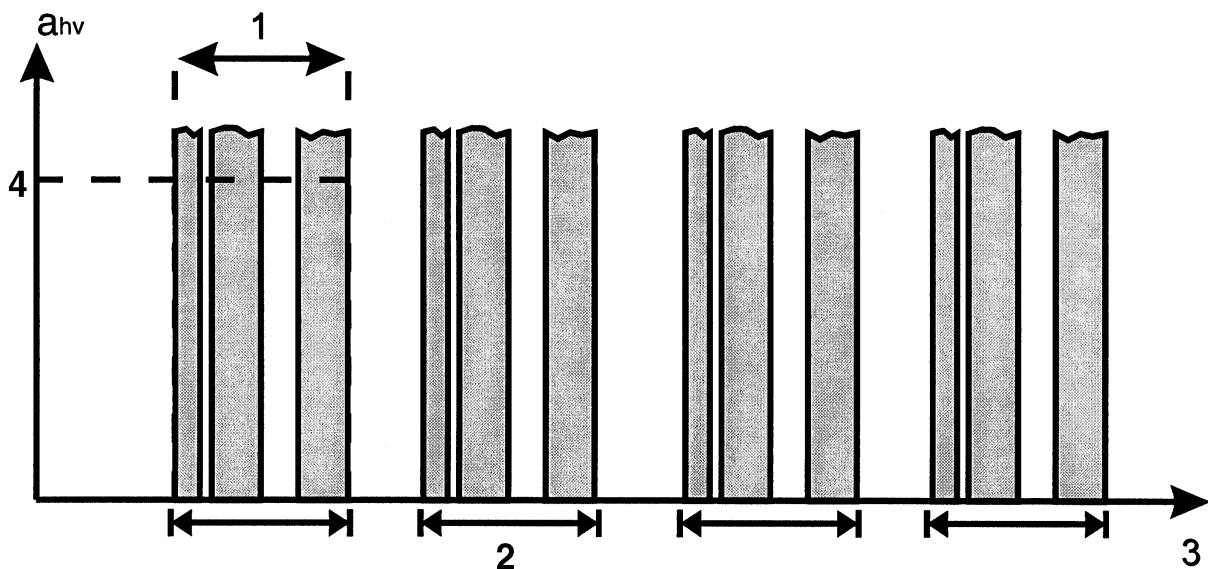
Each cycle takes 2 min to complete. At a work rate of 100 castings per day, the total daily exposure time is then 200 min, i.e. 3 h 20 min (3,33 h). The daily vibration exposure,  $A(8)$ , is given by equation (1) which for a single exposure is:

$$A(8) = a_{hv} \sqrt{\frac{T}{T_0}} \tag{E.2}$$

$$= 3,6 \sqrt{\frac{3,33}{8}} = 2,3 \text{ m/s}^2$$

**NOTE 1** For power tools such as hand-held grinders, it is likely that the vibration magnitude at the left and right hand positions will be different, it is possible that the exposure durations of the two hands may also differ. In such cases vibration exposure evaluations will need to be made for each hand.

**NOTE 2** E.2.3 shows an alternative analysis procedure for the same work process.



**Key**

- 1 Measurement duration
- 2 Exposure time = Total use time
- 3 Time
- 4  $a_{hv, \text{measured}}$

**Figure E.2 – Long-term measurement of intermittent exposures**

### E.2.3 Short-term measurement of intermittent tool operation

For many power tools, the hand is always in contact with the power tool or hand-held workpiece during use, but the power tool is not operated continuously (long breaks in operation) when it is used, or the hand is taken off the power tool during use. Examples of these types of operation include the use of hand-held grinders, pedestal grinders, chain saws, brush-saws and scaling hammers.

In these cases

- carry out a short-term measurement of vibration magnitude over a period of continuous operation. This may have to be a simulation of uninterrupted work (e.g. using a scrap component for pedestal grinders);
- the exposure time is the time for which the power tool is being operated during the working day.

a) Advantages

The vibration magnitude may be applied easily to vibration exposure evaluations in other situations, where the exposure times may be different.

b) Disadvantages

The vibration evaluation does not comprise periods when the machine is building up to operating speed and running back down to idling or off. If run-up or run-down times are comparable to the time spent at operating speed then this method may not correctly evaluate overall vibration exposure.

**EXAMPLE** A grinder is used to grind disk-shaped castings. Work records show that an average of 100 castings are worked on per day. For each casting the operator grinds around the circumference of the casting and then works on the upper and lower faces. The vibration exposure pattern is similar to that shown in Figure E.3.

Each cycle is made up of three periods of use:

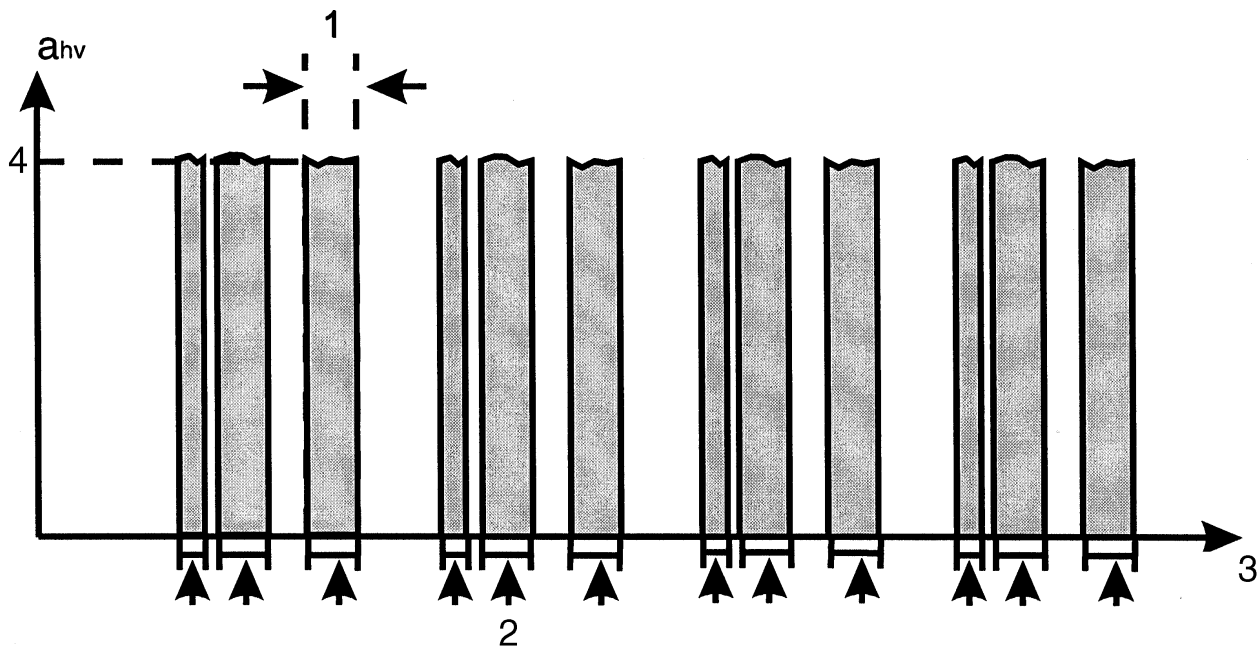
- 20 s to grind the circumference;
- 40 s to grind the top face, the casting is then turned over, and
- 40 s to grind the lower face.

The grinder is therefore operated for a total of 100 s in each work cycle (i.e. the power tool is operated for 1 min 40 s of the 2-min work cycle). At a work rate of 100 castings per day, the total daily exposure time is then 167 min, i.e. 2 h 47 min (2,78 h).

Simulated work measurements, using continuous grinding on scrap castings have established that the vibration magnitude during grinding is 3,9 m/s<sup>2</sup>. The daily vibration exposure,  $A(8)$ , is given by equation (1) which for a single exposure is:

$$\begin{aligned} A(8) &= a_{hv} \sqrt{\frac{T}{T_0}} \\ &= 3,9 \sqrt{\frac{2,78}{8}} = 2,3 \text{m/s}^2 \end{aligned} \tag{E.3}$$

**NOTE** E.2.2 shows an alternative analysis procedure for the same work process.



**Key**

- 1 Measurement duration
- 2 Exposure time = Total operating time
- 3 Time
- 4  $a_{hv, measured}$

**Figure E.3 – Short-term measurement of intermittent exposures**

**E.2.4 Fixed-duration measurement of single impacts or bursts of tool operation**

For some power tools, the power tool produces single impacts, or bursts of vibration; the impacts or bursts are irregular, with long breaks between them. Examples of these types of operation include the use of nail guns and powered impact wrenches.

In this case

- carry out a measurement of the average vibration magnitude over a fixed duration which includes a known number of impacts or bursts (which may be one or more);
- the exposure time is the measurement duration multiplied by the number of impacts per day divided by the number of impacts or burst in the measurement period.

a) Advantages

The vibration magnitude may be applied to vibration exposure evaluations in other situations (provided that the measurement duration is recorded).

b) Disadvantages

It is not currently clear whether this method (based on ISO 5349-1) is appropriate for measurement of shock vibration.

**EXAMPLE** A powered impact wrench is used for fitting wheel nuts. Each vehicle requires 20 wheel nuts. The tool operator normally uses the impact wrench for five wheel nuts, then puts the power tool down, while repositioning to the next wheel. Work records show that, on average, 50 vehicles are completed per day, i.e. 1000 wheel nuts.

Measurements of vibration magnitude can only be made over the time taken to fix five wheel nuts. In this case the impact wrench is held by the operator for at least 20 s, therefore a fixed-duration measurement of 20 s has been used for measurements of tightening five wheel nuts, see Figure E.4. The average vibration magnitude for the 20-s period is 14,6 m/s<sup>2</sup>. At least four measurements are necessary to ensure a total averaging time of greater than 60 s.

The total daily exposure time is:

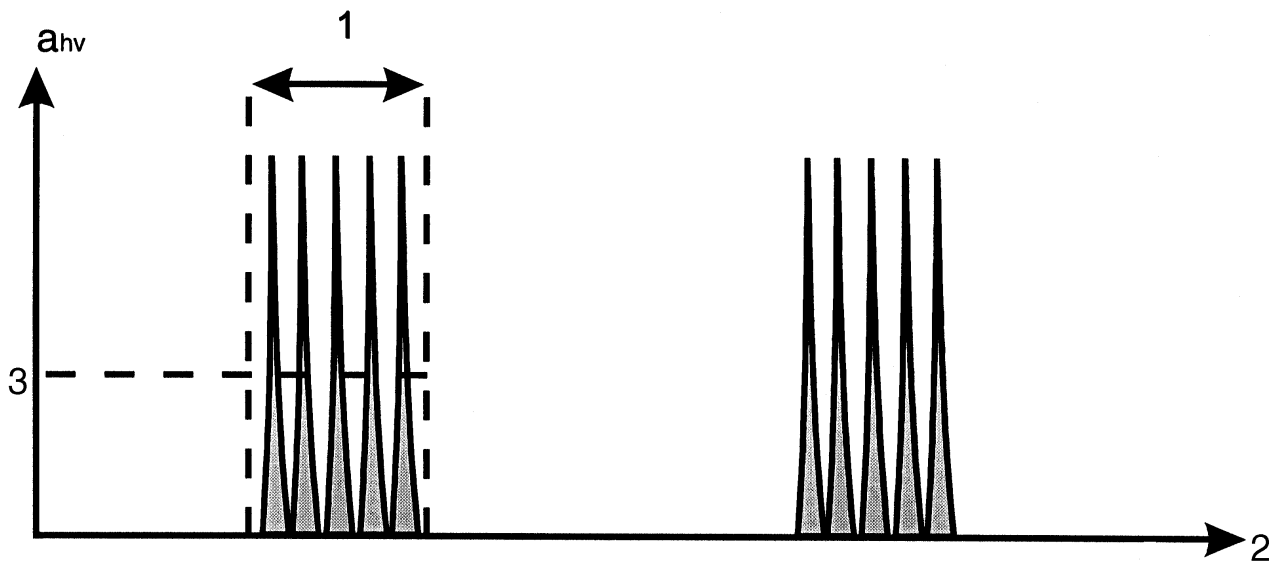
$$T = \frac{\text{number of nuts per day}}{\text{number of nuts in measurement period}} \times \text{measurement duration} \tag{E.4}$$

$$= \frac{1000}{5} \times 20\text{s} = 4000\text{s}$$

The total daily exposure time is 4000 s, i.e. 1 h 6,7 min (1,1 h), and the vibration magnitude,  $a_{hv}$ , is 14,6 m/s<sup>2</sup>, therefore, the daily vibration exposure,  $A(8)$ , is:

$$A(8) = a_{hv} \sqrt{\frac{T}{T_0}} \tag{E.5}$$

$$= 14,6 \sqrt{\frac{1,1}{8}} = 5,4\text{m/s}^2$$



**Key**

Exposure time = measurement duration multiplied by the number of impacts per day divided by the number of impacts within the measurement duration

- 1 Measurement duration
- 2 Time
- 3  $a_{hv,measured}$

**Figure E.4 – Fixed-duration measurement of single impacts or bursts of tool operation**

### E.3 Example of vibration evaluation where more than one power tool is used

Where more than one power tool or process contributes to the daily vibration exposure, the appropriate methods indicated in E.2 should be used to determine a partial vibration exposure for each individual power tool or process.

It is common to find in many work situations

- more than one vibrating power tool is used, or
- power tool with more than one mode of operation, each of which exposes the operator to different vibration magnitudes.

Where more than one power tool, process or operating mode is involved it is common to use combinations of the basic evaluation methods given in E.2.

**EXAMPLE** In this example, the daily vibration exposure can be identified as arising from three separate tasks. In calculating the total daily vibration exposure the three tasks are analysed separately, to calculate partial vibration exposures. In this case it is appropriate to use different methods of evaluation for each task.

A forestry worker spends the first part of a working day using a brush-saw for clearance work in a forest, where the operator works continuously for 2 h. The second part of the day is spent using a chain saw, where trees are first felled and then the trunks are stripped of branches; 30 trees are felled and stripped per day.

The pattern of vibration exposure is similar to that shown in Figure E.5. The evaluation of daily vibration exposure can be approached by dividing the day into three tasks: brush-saw operation, felling and stripping.

For the brush-saw operation, the work is continuous for 2 h. The vibration magnitude is measured over several sample periods of use, giving an average of 4,6 m/s<sup>2</sup>. The partial vibration exposure,  $A_{\text{brushsaw}}(8)$ , is calculated using equation (2):

$$A_i(8) = a_{\text{hvi}} \sqrt{\frac{T_i}{T_0}} \quad (\text{E.6})$$

$$A_{\text{brushsaw}}(8) = 4,6 \sqrt{\frac{2}{8}} = 2,3 \text{ m/s}^2$$

Using a chain saw for felling, each tree takes, on average, 2 min, i.e. a total of 1 h for 30 trees. The average vibration magnitude measured during the period of felling is 6 m/s<sup>2</sup>. As for the brush-saw, the partial vibration exposure,  $A_{\text{felling}}(8)$ , is calculated using equation (2):

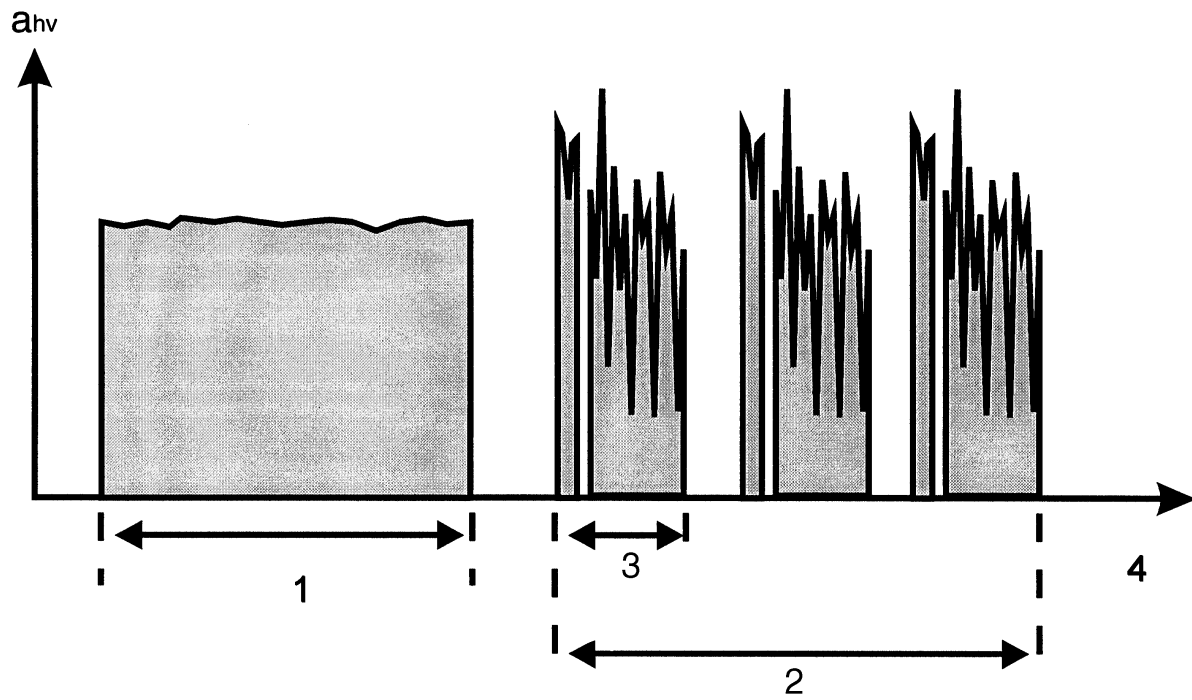
$$A_{\text{felling}}(8) = 6,0 \sqrt{\frac{1}{8}} = 2,1 \text{ m/s}^2 \quad (\text{E.7})$$

The stripping of the branches from each felled tree takes an average of 4 min, i.e. 2 h for 30 trees. The vibration value rises and falls as the saw cuts through individual branches, so a long-term average is taken, to include a representative period of this operation. The average vibration magnitude measured during the period of stripping is 3,6 m/s<sup>2</sup>. The partial vibration exposure,  $A_{\text{stripping}}(8)$ , is calculated using equation (2):

$$A_{\text{stripping}}(8) = 3,6 \sqrt{\frac{2}{8}} = 1,8 \text{ m/s}^2 \quad (\text{E.8})$$

The partial vibration exposures from the three contributors to the daily vibration exposure are combined using equation (3), to give the 8-h energy-equivalent vibration total value (daily vibration exposure),  $A(8)$ :

$$\begin{aligned} A(8) &= \sqrt{\sum_{i=1}^n A_i^2(8)} = \sqrt{A_{\text{brushsaw}}^2(8) + A_{\text{felling}}^2(8) + A_{\text{stripping}}^2(8)} \\ &= \sqrt{2,3^2 + 2,1^2 + 1,8^2} = 3,6 \text{ m/s}^2 \end{aligned} \quad (\text{E.9})$$











**Key**

- 1 Tool 1
- 2 Tool 2
- 3 Work cycle
- 4 Time

**Figure E.5 – Measurement of vibration exposures from more than one power tool**



## Bibliography

- [1] ISO 5348, *Mechanical vibration and shock – Mechanical mounting of accelerometers.*
- [2]  *Text deleted* 
- [3]  *Text deleted* 
- [4]  ISO 20643, *Mechanical vibration — Hand-held and hand-guided machinery — Principles for evaluation of vibration emission* 
- [5]  *Text deleted* 
- [6] Health and Safety Executive HS(G)88: Hand-Arm Vibration. Published: HSE Books, Sudbury, Suffolk, United Kingdom, 1994
- [7] Kaulbars, U.: *Vibration am Arbeitsplatz; Grundlagen, Messerfahrungen und praktische Hinweise für den Arbeitsschutz.* Verlag TÜV Rheinland, Köln, 1994

# British Standards Institution (BSI)

BSI is the national body responsible for preparing British Standards and other standards-related publications, information and services.

BSI is incorporated by Royal Charter. British Standards and other standardization products are published by BSI Standards Limited.

## About us

We bring together business, industry, government, consumers, innovators and others to shape their combined experience and expertise into standards-based solutions.

The knowledge embodied in our standards has been carefully assembled in a dependable format and refined through our open consultation process. Organizations of all sizes and across all sectors choose standards to help them achieve their goals.

## Information on standards

We can provide you with the knowledge that your organization needs to succeed. Find out more about British Standards by visiting our website at [bsigroup.com/standards](http://bsigroup.com/standards) or contacting our Customer Services team or Knowledge Centre.

## Buying standards

You can buy and download PDF versions of BSI publications, including British and adopted European and international standards, through our website at [bsigroup.com/shop](http://bsigroup.com/shop), where hard copies can also be purchased.

If you need international and foreign standards from other Standards Development Organizations, hard copies can be ordered from our Customer Services team.

## Subscriptions

Our range of subscription services are designed to make using standards easier for you. For further information on our subscription products go to [bsigroup.com/subscriptions](http://bsigroup.com/subscriptions).

With **British Standards Online (BSOL)** you'll have instant access to over 55,000 British and adopted European and international standards from your desktop. It's available 24/7 and is refreshed daily so you'll always be up to date.

You can keep in touch with standards developments and receive substantial discounts on the purchase price of standards, both in single copy and subscription format, by becoming a **BSI Subscribing Member**.

**PLUS** is an updating service exclusive to BSI Subscribing Members. You will automatically receive the latest hard copy of your standards when they're revised or replaced.

To find out more about becoming a BSI Subscribing Member and the benefits of membership, please visit [bsigroup.com/shop](http://bsigroup.com/shop).

With a **Multi-User Network Licence (MUNL)** you are able to host standards publications on your intranet. Licences can cover as few or as many users as you wish. With updates supplied as soon as they're available, you can be sure your documentation is current. For further information, email [bsmusales@bsigroup.com](mailto:bsmusales@bsigroup.com).

## Revisions

Our British Standards and other publications are updated by amendment or revision.

We continually improve the quality of our products and services to benefit your business. If you find an inaccuracy or ambiguity within a British Standard or other BSI publication please inform the Knowledge Centre.

## Copyright

All the data, software and documentation set out in all British Standards and other BSI publications are the property of and copyrighted by BSI, or some person or entity that owns copyright in the information used (such as the international standardization bodies) and has formally licensed such information to BSI for commercial publication and use. Except as permitted under the Copyright, Designs and Patents Act 1988 no extract may be reproduced, stored in a retrieval system or transmitted in any form or by any means – electronic, photocopying, recording or otherwise – without prior written permission from BSI. Details and advice can be obtained from the Copyright & Licensing Department.

## Useful Contacts:

### Customer Services

**Tel:** +44 845 086 9001

**Email (orders):** [orders@bsigroup.com](mailto:orders@bsigroup.com)

**Email (enquiries):** [cservices@bsigroup.com](mailto:cservices@bsigroup.com)

### Subscriptions

**Tel:** +44 845 086 9001

**Email:** [subscriptions@bsigroup.com](mailto:subscriptions@bsigroup.com)

### Knowledge Centre

**Tel:** +44 20 8996 7004

**Email:** [knowledgecentre@bsigroup.com](mailto:knowledgecentre@bsigroup.com)

### Copyright & Licensing

**Tel:** +44 20 8996 7070

**Email:** [copyright@bsigroup.com](mailto:copyright@bsigroup.com)

## BSI Group Headquarters

389 Chiswick High Road London W4 4AL UK



...making excellence a habit.™