

Acoustics — Determination of sound power radiated into a duct by fans and other air-moving devices — In-duct method (ISO 5136:2003)

ICS 17.140.20; 23.120

National foreword

This British Standard is the UK implementation of EN ISO 5136:2009. It is identical to ISO 5136:2003. It supersedes BS EN ISO 5136:2003 which is withdrawn.

The UK participation in its preparation was entrusted to Technical Committee EH/1/4, Machinery noise.

A list of organizations represented on this committee can be obtained on request to its secretary.

This publication does not purport to include all the necessary provisions of a contract. Users are responsible for its correct application.

Compliance with a British Standard cannot confer immunity from legal obligations.

This British Standard was published under the authority of the Standards Policy and Strategy Committee on 30 April 2010

© BSI 2010

ISBN 978 0 580 67418 1

Amendments/corrigenda issued since publication

Date	Comments

English Version

Acoustics - Determination of sound power radiated into a duct by fans and other air-moving devices - In-duct method (ISO 5136:2003)

Acoustique - Détermination de la puissance acoustique rayonnée dans un conduit par des ventilateurs et d'autres systèmes de ventilation - Méthode en conduit (ISO 5136:2003)

Akustik - Bestimmung der von Ventilatoren und anderen Strömungsmaschinen in Kanäle abgestrahlten Schalleistung - Kanalverfahren (ISO 5136:2003)

This European Standard was approved by CEN on 20 July 2009.

CEN members are bound to comply with the CEN/CENELEC Internal Regulations which stipulate the conditions for giving this European Standard the status of a national standard without any alteration. Up-to-date lists and bibliographical references concerning such national standards may be obtained on application to the CEN Management Centre or to any CEN member.

This European Standard exists in three official versions (English, French, German). A version in any other language made by translation under the responsibility of a CEN member into its own language and notified to the CEN Management Centre has the same status as the official versions.

CEN members are the national standards bodies of Austria, Belgium, Bulgaria, Cyprus, Czech Republic, Denmark, Estonia, Finland, France, Germany, Greece, Hungary, Iceland, Ireland, Italy, Latvia, Lithuania, Luxembourg, Malta, Netherlands, Norway, Poland, Portugal, Romania, Slovakia, Slovenia, Spain, Sweden, Switzerland and United Kingdom.



EUROPEAN COMMITTEE FOR STANDARDIZATION
COMITÉ EUROPÉEN DE NORMALISATION
EUROPÄISCHES KOMITEE FÜR NORMUNG

Management Centre: Avenue Marnix 17, B-1000 Brussels

Foreword

The text of ISO 5136:2003 has been prepared by Technical Committee ISO/TC 43 "Acoustics" of the International Organization for Standardization (ISO) and has been taken over as EN ISO 5136:2009 by Technical Committee CEN/TC 211 "Acoustics" the secretariat of which is held by DS.

This European Standard shall be given the status of a national standard, either by publication of an identical text or by endorsement, at the latest by February 2010, and conflicting national standards shall be withdrawn at the latest by February 2010.

Attention is drawn to the possibility that some of the elements of this document may be the subject of patent rights. CEN [and/or CENELEC] shall not be held responsible for identifying any or all such patent rights.

This document supersedes EN ISO 5136:2003.

This document has been prepared under a mandate given to CEN by the European Commission and the European Free Trade Association, and supports essential requirements of EC Directives.

For relationship with EC Directives, see informative Annexes ZA and ZB, which are integral parts of this document.

According to the CEN/CENELEC Internal Regulations, the national standards organizations of the following countries are bound to implement this European Standard: Austria, Belgium, Bulgaria, Cyprus, Czech Republic, Denmark, Estonia, Finland, France, Germany, Greece, Hungary, Iceland, Ireland, Italy, Latvia, Lithuania, Luxembourg, Malta, Netherlands, Norway, Poland, Portugal, Romania, Slovakia, Slovenia, Spain, Sweden, Switzerland and the United Kingdom.

Endorsement notice

The text of ISO 5136:2003 has been approved by CEN as a EN ISO 5136:2009 without any modification.

Annex ZA (informative)

Relationship between this European Standard and the Essential Requirements of EU Directive 98/37/EC

This European Standard has been prepared under a mandate given to CEN by the European Commission and the European Free Trade Association to provide a means of conforming to Essential Requirements of the New Approach Directive 98/37/EC, amended by 98/79/EC on machinery.

Once this standard is cited in the Official Journal of the European Communities under that Directive and has been implemented as a national standard in at least one Member State, compliance with the normative clauses of this standard confers, within the limits of the scope of this standard, a presumption of conformity with the relevant Essential Requirements of that Directive and associated EFTA regulations.

WARNING - Other requirements and other EU Directives may be applicable to the product(s) falling within the scope of this standard.

Annex ZB (informative)

Relationship between this European Standard and the Essential Requirements of EU Directive 2006/42/EC

This European Standard has been prepared under a mandate given to CEN by the European Commission and the European Free Trade Association to provide a means of conforming to Essential Requirements of the New Approach Directive 2006/42/EC on machinery.

Once this standard is cited in the Official Journal of the European Communities under that Directive and has been implemented as a national standard in at least one Member State, compliance with the normative clauses of this standard confers, within the limits of the scope of this standard, a presumption of conformity with the relevant Essential Requirements of that Directive and associated EFTA regulations.

WARNING — Other requirements and other EU Directives may be applicable to the product(s) falling within the scope of this standard.

Contents

Page

Foreword	iv
Introduction	v
1 Scope	1
1.1 General	1
1.2 Types of sound source	1
2 Normative references	2
3 Terms, definitions and symbols	2
4 Uncertainty of the measurement method	7
5 Test facilities and instrumentation	8
5.1 General requirements	8
5.2 Duct specifications	9
5.3 Instrumentation	16
5.4 System calibration	19
6 Test arrangement	20
6.1 Sampling tube mounting	20
6.2 Microphone position	20
6.3 Operating condition control equipment	21
7 Test procedure	21
7.1 Operating conditions	21
7.2 Sound pressure level readings	21
7.3 Measurements with and without flow straightener on the outlet side	22
7.4 Inlet side measurements — Large fans: installation category D (according to ISO 5801:1997)	22
8 Calculations	23
8.1 Average sound pressure level	23
8.2 Sound power level	23
9 Information to be recorded	24
10 Information to be reported	24
Annex A (normative) Determination of the combined mean flow velocity and modal correction $C_{3,4}$	25
Annex B (normative) Determination of the signal-to-noise ratio of sound vs. turbulent pressure fluctuation in the test duct	31
Annex C (normative) Computational procedures for calculating the A-weighted sound power level from one-third-octave-band sound power levels	34
Annex D (informative) Example of calculation of $C_{3,4}$ for a given duct diameter and mean flow velocity	35
Annex E (informative) Guidelines for the design and construction of an anechoic termination	38
Annex F (informative) Evaluation of performance of anechoic terminations	47
Annex G (informative) Sampling tube information	50
Annex H (informative) Test method for small ducted fans	54
Annex I (informative) Test method for large ducted fans	58
Annex J (informative) Measurement of the swirl component	65
Bibliography	66

Foreword

ISO (the International Organization for Standardization) is a worldwide federation of national standards bodies (ISO member bodies). The work of preparing International Standards is normally carried out through ISO technical committees. Each member body interested in a subject for which a technical committee has been established has the right to be represented on that committee. International organizations, governmental and non-governmental, in liaison with ISO, also take part in the work. ISO collaborates closely with the International Electrotechnical Commission (IEC) on all matters of electrotechnical standardization.

International Standards are drafted in accordance with the rules given in the ISO/IEC Directives, Part 2.

The main task of technical committees is to prepare International Standards. Draft International Standards adopted by the technical committees are circulated to the member bodies for voting. Publication as an International Standard requires approval by at least 75 % of the member bodies casting a vote.

Attention is drawn to the possibility that some of the elements of this document may be the subject of patent rights. ISO shall not be held responsible for identifying any or all such patent rights.

ISO 5136 was prepared by Technical Committee ISO/TC 43, *Acoustics*, Subcommittee SC 1, *Noise*.

This second edition cancels and replaces the first edition (ISO 5136:1990), which has been technically revised.

Introduction

This International Standard describes a procedure for the measurement of sound pressure levels in the inlet or outlet ducts of a fan and a method to use these sound pressure levels to calculate the sound power levels radiated by the fan to the duct system.

Annex A lists values of coefficients for the determination of the combined mean flow velocity and modal correction. Annex B specifies two procedures for the determination of the signal-to-noise ratio of sound versus turbulence. A computational procedure for the calculation of the A-weighted sound power level from one-third-octave band levels is given in Annex C. Annex D shows an example of the calculation of the combined mean flow velocity and modal correction.

The sound power radiated into a duct by a fan or other air-moving device depends to some extent on the type of duct, characterized by its acoustical impedance. For a measurement method, the test duct has, therefore, to be clearly specified. In this International Standard, the test duct is of circular cross-section and terminated anechoically. Details of typical anechoic terminations are given in Annex E. The sound power obtained under these special conditions is a representative value for actual applications, as the anechoic termination forms an impedance about midway between the higher and lower impedances found in practice. The sound power radiated in actual applications can, in theory, be estimated from data on air-moving devices and duct impedances. Since this information is at present incomplete, these effects are not usually considered in acoustical calculations.

In order to suppress the turbulent pressure fluctuations at the microphone, the use of a long cylindrical windscreen ("sampling tube") is preferred. The microphone, with the sampling tube, is mounted at a radial position such that the sound pressure is well related to the sound power by the plane wave formula to an acceptable extent, even in the frequency range in which higher-order acoustic modes are possible.

The uncertainty of measurement (see Clause 4) is given in terms of the standard deviation to be expected if the measurements were repeated in many different laboratories.

The procedures for measuring the operating conditions (performance measurements) are not specified in detail in this International Standard. The operating conditions are specified in ISO 5801.

This International Standard is one of a series specifying different methods for determining the sound power levels of fans and other air-moving devices.

In general, the sound powers radiated from a fan inlet or outlet into free space and into a duct are different because of the reflection of sound energy at the fan inlet or outlet plane when there is no connected duct. The in-duct method according to this International Standard is suitable for determining the sound power radiated into a duct by a fan inlet or outlet. The sound power radiated into free space by a fan inlet or outlet should be determined using the a reverberation room method (ISO 3741, ISO 3743), a free-field method (ISO 3744, ISO 3745, ISO 3746) or a sound intensity method (ISO 9614).

Acoustics — Determination of sound power radiated into a duct by fans and other air-moving devices — In-duct method

1 Scope

1.1 General

This International Standard specifies a method for testing ducted fans and other air-moving devices to determine the sound power radiated into an anechoically terminated duct on the inlet and/or outlet side of the equipment.

NOTE 1 For the sake of brevity, wherever the term “fan” occurs in the text, it means “fan or other air-moving device”.

The method is applicable to fans which emit steady, broad-band, narrow-band and discrete-frequency sound and to air temperatures between -50 °C and $+70\text{ °C}$. The test duct diameter range is from 0,15 m to 2 m. Test methods for small ($d < 0,15\text{ m}$) and large ($d > 2\text{ m}$) test ducts are described in the informative Annexes H and I, respectively.

The maximum mean flow velocity at the microphone head for which the method is suitable depends on the type of microphone shield used, and is as follows:

- foam ball 15 m/s;
- nose cone 20 m/s;
- sampling tube 40 m/s.

Above these values the suppression of turbulent pressure fluctuations by the microphone shield (see 3.9) may be insufficient.

It is expected that sound power tests will be conducted in conjunction with airflow performance tests in accordance with ISO 5801. The ducting arrangement will therefore normally incorporate a “star” type flow straightener on the outlet side of the fan which will minimize swirl (see 7.3). Where it is permissible to delete the straightener as, for example, with large fans to installation category C according to ISO 5801:1997, the method is limited to a swirl angle of 15° . (An example of a method for determining the angle of swirl is given in Annex J.)

NOTE 2 The installation categories defined in ISO 5801 imply that the fan is either ducted on the outlet side only (category B), on the inlet side only (category C) or on both sides (category D).

1.2 Types of sound source

The method described in this International Standard is applicable to a sound source in which a fan is connected to ducts on at least one side. It is also applicable to other fan/attenuator combinations or equipment incorporating fans which can be considered as “black boxes”.

Examples of fans and other equipment covered by this International Standard are

- ducted centrifugal fans,
- ducted axial flow fans,

- ducted mixed-flow fans,
- ducted air-handling units,
- ducted dust-collection units,
- ducted air-conditioning units, and
- ducted furnaces.

This International Standard is also applicable to other aerodynamic sources such as boxes, dampers and throttle devices provided that a quiet air flow delivered by an auxiliary fan is available, and the signal-to-noise ratio of sound pressures to turbulent pressure fluctuations in the test duct is at least 6 dB (see 7.2.1).

An alternative method to determine the sound power level of the flow-generated noise of such aerodynamic sound sources, which does not require the measurement of sound pressure in a flow environment, is described in ISO 7235. The method was originally devised for the determination of the flow noise level of ducted silencers. The sound power is determined in a reverberation room connected to the test duct via a transition element.

In the case of ducted fans with closely coupled attenuators, the signal-to-noise ratio of sound pressures to turbulent pressures may be insufficient when using the in-duct method. Therefore the method described in ISO 7235 is recommended for such fan/attenuator combinations.

This International Standard is not applicable to non-ducted fans or equipment.

2 Normative references

The following referenced documents are indispensable for the application of this document. For dated references, only the edition cited applies. For undated references, the latest edition of the referenced document (including any amendments) applies.

ISO 266, *Acoustics — Preferred frequencies*

ISO 5801:1997, *Industrial fans — Performance testing using standardized airways*

IEC 60651:2001, *Sound level meters*

IEC 60942:1997, *Electroacoustics — Sound calibrators*

IEC 61260, *Electroacoustics — Octave-band and fractional-octave-band filters*

3 Terms, definitions and symbols

For the purpose of this document, the following terms and definitions apply. The symbols are given in Table 1.

3.1 fan inlet area

S_{f1}
surface plane bounded by the upstream extremity of the fan

NOTE 1 The inlet area is, by convention, taken as the gross area in the inlet plane inside the casing. No deduction is made for motors, fairings or other obstructions.

NOTE 2 Where motors, fairings or other obstructions extend beyond an inlet or outlet flange at which the performance for ducted installation is to be determined, the casing should be extended by a duct of the same size and shape as the inlet or outlet and of sufficient length to cover the obstruction. The test airway dimensions should be measured from the plane through the outermost extension of the obstruction as if this were the plane of the inlet or outlet flange.

NOTE 3 The fan inlet area is expressed in square metres (m²).

NOTE 4 Adapted from ISO 5801:1997.

3.2 fan outlet area

S_{f2}
 surface plane bounded by the downstream extremity of the fan

NOTE 1 The outlet area is, by convention, taken as the gross area in the outlet plane inside the casing. No deduction is made for motors, fairings or other obstructions.

NOTE 2 Some free-outlet fans without casings have no well-defined outlet area. For the purpose of determining the fan's dynamic pressure, a nominal area may then be defined and stated, e.g. the area within the ring of a propeller wall fan or the circumferential outlet area of an open-running centrifugal impeller. The corresponding fan dynamic pressure and fan pressure will also be nominal and should be so described.

NOTE 3 The fan outlet area is expressed in square metres (m²).

NOTE 4 Adapted from ISO 5801:1997.

3.3 ducts

any of the airways defined in 3.3.1, 3.3.2 and 3.3.3

3.3.1 test duct

duct in which the fan sound power is measured

NOTE The test duct has an anechoic termination.

3.3.2 terminating duct

duct opposite to the test duct, if both sides of the fan are ducted

NOTE The terminating duct has an anechoic termination.

3.3.3 intermediate duct

duct fitted on the intake side and on the discharge side of the fan to ensure desired flow conditions

NOTE The intermediate duct connects to the test duct or the terminating duct, if necessary by a transition section (see Figure 7).

3.4 measurement plane

radial plane in the test duct in which the microphone diaphragm is located

3.5 sound pressure level

L_p

$$L_p = 10 \lg \frac{p^2}{p_0^2} \text{ dB} \quad (1)$$

where p is the root mean square value of the sound pressure and the reference sound pressure p_0 is equal to 20 μPa

NOTE 1 The width of a restricted frequency band should be indicated, for example, octave-band sound pressure level, one-third-octave-band sound pressure level.

NOTE 2 L_{p1} , L_{p2} and L_{p3} are the sound pressure levels at each of the three measurement positions in the test duct.

$\overline{L_{pm}}$ is the spatially averaged sound pressure level obtained from averaging over the measurement positions in the test duct. It may also be obtained from a continuous circumferential traverse (see 7.2.4).

$\overline{L_p}$ is the spatially averaged sound pressure level at the measurement plane, corrected for the combined free-field response C (see Table 1 and 8.1).

NOTE 3 The sound pressure level is expressed in decibels (dB).

3.6 sound power level

L_W

$$L_W = 10 \lg \frac{P}{P_0} \text{ dB} \quad (2)$$

where P is the sound power and the reference sound power P_0 is equal to 1 pW

NOTE 1 The width of a restricted frequency band should be indicated, for example, octave-band sound power level, one-third-octave-band sound power level.

NOTE 2 The sound power level is expressed in decibels (dB).

3.7 fan sound power

sound power radiated into the test duct by the fan

3.8 frequency band range of interest

one-third-octave bands with centre frequencies between 50 Hz and 10 000 Hz

NOTE For information only, the frequency range of interest may be extended up to 20 000 Hz. For fans which radiate predominantly high- or low-frequency sound, the frequency range of interest may be limited in order to reduce the costs of the test facilities and procedures. The limits of the restricted frequency range shall be given in the test report.

3.9 microphone shield

device designed to protect a microphone placed in a moving airstream from self-generated wind noise and turbulent pressure fluctuations

NOTE 1 See Clause 4, Note 5.

NOTE 2 The three types are listed in order of preference in 3.9.1, 3.9.2 and 3.9.3.

3.9.1 sampling tube turbulence screen

metal tube with a longitudinal slit, covered by a porous material within which the microphone is positioned, designed to reduce the response of the microphone to self-induced wind noise and to turbulent pressure fluctuations of the air pressure within the duct

See Figure 1.

NOTE 1 The sampling tube is the preferred microphone shield for measurements according to this International Standard.

NOTE 2 To minimize self-induced wind noise, the outer surface of the tube should be smooth and free of any discontinuities (see Figure 1). The slit and covering of the sampling tube should be designed to reduce the response of the microphone to turbulent pressure fluctuations in the air stream emanating from the fan being tested.

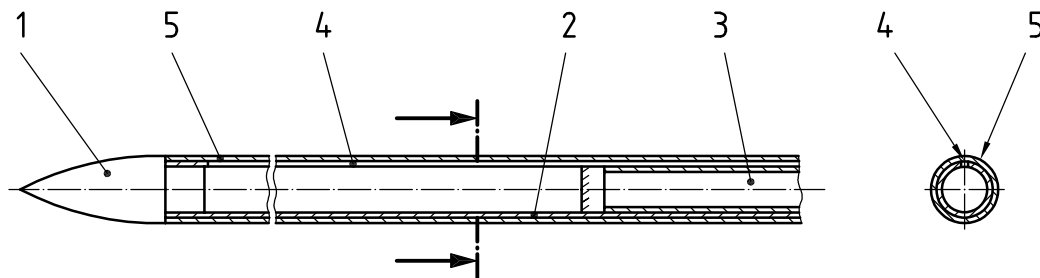

Key

- 1 nose cone
- 2 slit-tube
- 3 microphone
- 4 slit
- 5 porous material

Figure 1 — Schematic of a sampling tube for a 13 mm (1/2 inch) microphone

**3.9.2
nose cone**

microphone shield designed to substitute the normal protection grid of the microphone and used in high-velocity air flows with low turbulence and little swirl having a streamlined shape with the least possible resistance to airflow and a fine wire mesh around its periphery allowing sound pressure transmission to the microphone diaphragm, whilst a truncated cone behind the mesh reduces the air volume in form of the diaphragm

See Figure 2.

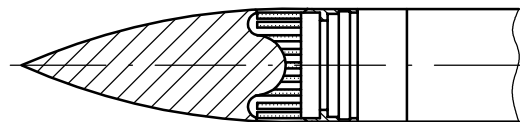

Figure 2 — Schematic of a nose cone

**3.9.3
foam ball**

ball of open-pored foam with a cylindrical hole of appropriate diameter for insertion of the microphone and preamplifier, designed not to affect the directivity of the microphone

See Figure 3.

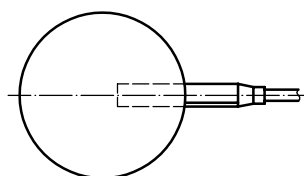

Figure 3 — Schematic of a foam ball

3.10
frequency range of plane-wave sound propagation in a duct with circular cross section
 frequencies, in hertz, below the cut-on frequency of the first cross mode, $f_{1,0}$, as given by

$$f_{1,0} = 0,586 \frac{c}{D} \sqrt{1 - \left(\frac{U}{c}\right)^2} \quad (3)$$

where

- c is the speed of sound, approximately 340 m/s;
- D is the duct diameter, in metres;
- U is the mean flow velocity, in metres per second.

Table 1 — Symbols

C_1	correction in decibels supplied by the manufacturer to be added to the calibrated microphone response to obtain the free field response.
C_2	frequency response correction in decibels of the sampling tube microphone shield at normal incidence to be added to the calibrated microphone response. (See 5.3.3 and 5.3.4.)
$C_{3,4}$	combined mean flow velocity and modal correction in decibels for the frequency response required by the use of the sampling tube microphone shield. (See tables in Annexes A, H and I.)
$C = C_1 + C_2 + C_{3,4}$	combined frequency response correction, expressed in decibels.
c	speed of sound in the test duct, in metres per second.
U	mean flow velocity in the test duct, in metres per second.
ρ	fluid density, in kilograms per cubic metre, in the duct.
d	diameter, in metres, of the fan inlet (d_1), fan outlet (d_2), test duct (d_3 and d_6 in Figure 5), intermediate ducts (d_4), terminating ducts (d_6 in Figure 6 and d_3 in Figure 7).
l	length of the ducts and transitions (see Figures 5 to 7).
r	radial distance, in metres, from the test duct centreline to the microphone centreline.
r_a	dimensionless pressure reflection coefficient defined as the ratio of the sound pressure amplitude of the sound wave reflected from the anechoic termination to the sound pressure amplitude of the incident wave.
b, h	cross dimensions, in metres, of the rectangular fan inlet or fan outlet.
S	cross-sectional areas of ducts or duct sections, in square metres.

NOTE 1 In the first edition of ISO 5136 (1990), two correction terms C_3 and C_4 were used to account for the effect of the flow and the modal distribution in the sound field on the response of the sampling tube. In the present edition, these two effects are incorporated in the new combined correction term $C_{3,4}$.

NOTE 2 $U < 0$ for inlet side measurements; $U > 0$ for outlet side measurements.

4 Uncertainty of the measurement method

Determination of sound power made in accordance with this International Standard will tend to result in an uncertainty of sound power level given in terms of the values of the standard deviation of reproducibility given in Table 2. The standard deviations given in this table reflect the cumulative effects of all causes of measurement uncertainty such as source location, duct end reflections, duct transitions, instrument calibration, sound pressure to sound power computing and sampling errors. The standard deviations given in the table are those which would be expected if the measurement of a single fan were repeated in many different laboratories. They do not include variations in the sound power radiated by the fan itself caused, for example, by changes in the mounting arrangements. Care should be taken to obtain a specified time average in accordance with the requirements laid down in 7.2.2.

Table 2 — Values of the standard deviation of reproducibility for the sampling tube

One-third-octave band centre frequency Hz	Standard deviation of reproducibility, σ_R dB
50	3,5
63	3
80 to 100	2,5
125 to 4 000	2
5 000	2,5
6 300	3
8 000	3,5
10 000	4

NOTE The standard deviations given in Table 2 are derived from information in references [3], [5] and [19].

The procedures of this International Standard and the standard deviations given in Table 2 are applicable to measurements on an individual piece of equipment. Characterization of the sound power levels of batches of equipment of the same family or type involves the use of random sampling techniques in which confidence intervals are specified, and the results are expressed in terms of statistical upper limits. In applying these techniques, the total standard deviation must be known or estimated, including the standard deviation of production as defined in ISO 7574-1, which is a measure of the variation in sound power output between individual pieces of equipment within the batch. Statistical methods for the characterization of batches of equipment are described in ISO 7574-3 and ISO 7574-4.

The measurement uncertainty may be lowered by careful construction of the test set-up, by eliminating transition ducts, and by use of more absorptive terminating ducts.

For a particular family of sound sources, of similar size and with similar sound power spectra, the standard deviation of reproducibility could be smaller than the values given in Table 2. Hence, a test code for a particular type of equipment may state standard deviations smaller than those listed in Table 2 if substantiation is available from the results of suitable interlaboratory tests.

At high frequencies, particularly above 4 000 Hz, the standard deviation data quoted in Table 2 can underestimate the actual standard deviations when the noise spectrum being measured decreases rapidly with frequency. Under these conditions, the high-frequency sound pressure levels sensed by the microphone can be of small magnitude compared with those at low frequencies, and electrical noise, particularly from the frequency analyser, can interfere with the sound signal at these high frequencies. In order to achieve reproducible determinations of sound power (with standard deviations in Table 2) it may be necessary to repeat the high-frequency sound measurement by passing the microphone signal through a high pass filter before it is analysed by the frequency analyser.

NOTE 1 When octave-band sound power levels are calculated, the uncertainty of each octave-band level will not be greater than that of the largest uncertainty of the three constituent one-third-octave bands.

NOTE 2 For a normal distribution, 68 % of all data lie within an interval $\pm \sigma_R$, and 95 % lie within $\pm 2\sigma_R$.

NOTE 3 The uncertainty will increase in the presence of swirling flows.

NOTE 4 If discrete frequency components are present or if measurements are not averaged over a sufficiently long period (see 6.2.2), the uncertainty will be greater than that indicated.

NOTE 5 A microphone exposed to high air velocity will give a falsely high reading. This is rectified by fitting a shield such as a sampling tube, a nose cone or a foam ball. These are limited in their use (see 1.1) according to the mean flow velocity. Whilst the foam ball is omni-directional and reduces the wind-generated noise in all directions, a nose cone has to be aligned with the flow to reduce the wind-generated noise. Only the sampling tube, however, reduces the false noise generated by turbulent fluctuations of pressure to a sufficient degree. It is, therefore, the preferred solution for all cases. The uncertainties given in Table 2 refer to the sampling tube only and can be expected to increase for other shields.

NOTE 6 The standard deviations listed in Table 2 are associated with the test conditions and procedures defined in this International Standard and not with the noise source itself. They arise partly from variations between measurement laboratories in the geometry of the test facility, background noise, turbulent pressure fluctuations, and the type and calibration of instrumentation. They are also due to variations in experimental measurement techniques, including spatial averaging and integration times.

NOTE 7 If several laboratories use similar facilities and instrumentation, the results of sound power determinations on a given source in those laboratories may be in better agreement than would be inferred by the standard deviations of Table 2.

Measurements above 10 000 Hz may be reported, but are not considered part of this International Standard. The extrapolated values of the standard deviation given in Table 3 are suggested.

Table 3 — Extrapolated values

One-third-octave band centre frequency Hz	Standard deviation of reproducibility, σ_R dB
12 500	4,5
16 000	5
20 000	5,5

5 Test facilities and instrumentation

5.1 General requirements

The test arrangement shall consist of the fan to be tested, an intermediate duct, the test duct with anechoic termination, and the instrumentation (see Figures 5 to 7). If a fan usually used with duct work on both sides is to be tested, a termination duct with anechoic termination plus an intermediate duct shall be connected opposite to the side on which the sound power is determined.

All connections between the fan and the ducts shall be firm, unless a vibration-isolating coupling is an inherent part of the fan. The test ducts shall include provisions for mounting the microphone and sampling tube at the locations specified in 6.2.

Suitable provisions shall also be made for controlling the desired operating conditions of the fan.

It is recognised that acoustic and fan performance measurements are to be performed at the same time, and that the test arrangements of this International Standard and those of ISO 5801 should be in conformity. This requires that the common part as defined in ISO 5801 be introduced at the fan inlet and/or outlet.

NOTE 1 The presence of the “star-type” flow straightener on the fan outlet side is necessary for the measurement of the aerodynamic fan performance according to ISO 5801. However, the swirling flow entering the flow straightener may generate excess noise at the microphone position which may or may not be of higher level than the sound pressure level produced by the fan under test. On the other hand, without a flow straightener, the swirling flow around the measurement microphone may generate excess flow noise which may or may not be of higher level than the sound pressure level produced by the fan under test. For this reason, comparative sound measurements with and without the “star-type” flow straightener in position are specified (see 7.3).

NOTE 2 Examples of designs of anechoic terminations and throttling devices are given in Annex E.

5.2 Duct specifications

5.2.1 Construction of ducts and transitions

The ducts shall be straight, coaxial with the inlet or outlet of the fan, and of uniformly circular cross section. The ducts and transitions shall be manufactured either from steel having a minimum thickness of 1 mm or from a material of equivalent mass per unit area and rigidity which ensures an acoustically hard and smooth interior surface.

The ducts and transitions should preferably be treated with a vibration-damping material on the outside.

NOTE This International Standard specifies test ducts with circular cross sections. Future International Standards may involve ducts with other cross sections.

5.2.2 Duct lengths

Duct lengths shall be as specified in Figure 5.

5.2.3 Duct cross-sectional area

The duct cross-sectional areas shall be as specified in Table 4, where the inlet area S_{f1} or outlet area S_{f2} is the area on the side to which the respective duct is connected.

Table 4 — Cross-sectional areas of ducts

Duct		Cross-sectional area	
		min.	max.
Inlet side	Intermediate	$1 S_{f1}$	$1 S_{f1}$
	Test	$1 S_{f1}$	$2,1 S_{f1}$
	Terminating	$1 S_{f1}$	$2,1 S_{f1}$
Outlet side	Intermediate	$0,95 S_{f2}$	$1,07 S_{f2}$
	Test	$0,7 S_{f2}$	$2,1 S_{f2}$
	Terminating	$0,7 S_{f2}$	$2,1 S_{f2}$

5.2.4 Transition ducts

The test duct or terminating duct shall be coupled directly to the intermediate duct or, where there is a change of cross-sectional area, indirectly by means of a transition duct. The diameter ratio of the transition shall lie within the limits specified in Table 4.

For acoustic reasons (see references [9] and [26]), the length of the transition shall be such that the minimum length of transition, l_{\min} , conforms to

$$\frac{l_{\min}}{l_0} = \frac{S_1}{S_s} - 1 \quad (4)$$

where

$$l_0 = 1 \text{ m};$$

S_1 is the larger area;

S_s is the smaller area.

For aerodynamic reasons, the outlet transition shall have an included or valley angle not exceeding 15° .

The longer length as determined by the two criteria shall be used.

NOTE The valley angle of a transition is the angle α in Figure 4.

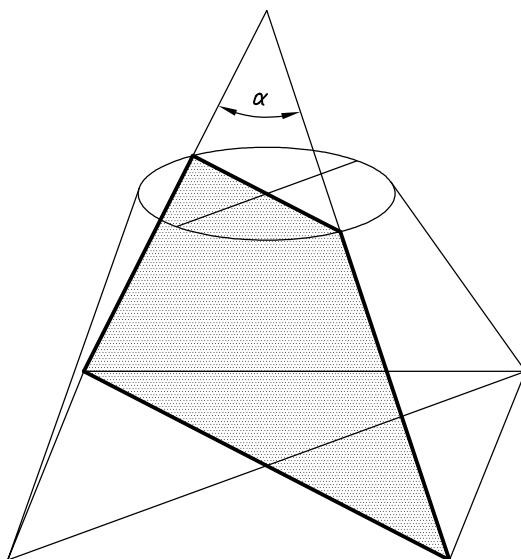
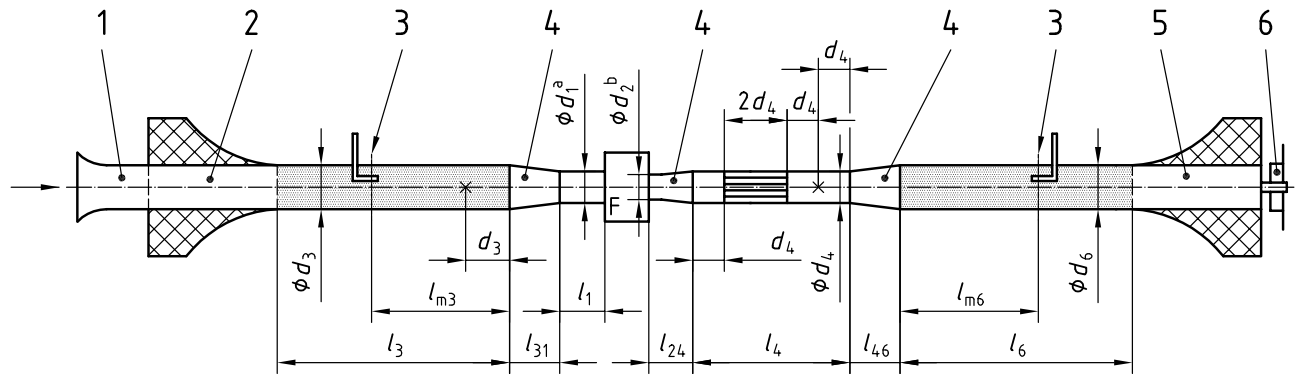

Figure 4 — Illustration of the valley angle

5.2.5 Terminating duct

On a test installation of category D according to ISO 5801:1997, when sound measurements are not to be made on one side, a cylindrical terminating duct shall be fitted on that side, coaxial with the fan inlet or outlet between the intermediate duct and anechoic termination. The diameter of the terminating duct shall be in accordance with Figures 5 to 7. The minimum length shall be one diameter or 1 m, whichever is the greater.

A transition piece complying with 5.2.4 may be fitted between the intermediate duct and the terminating duct.



Key

- 1 flow measurement (schematic)
- 2 anechoic termination (schematic)
- 3 measurement plane
- 4 conical or rectangular-to-round transition
- 5 anechoic termination (schematic)
- 6 throttle (schematic)

a The figure is drawn for circular duct cross sections. In the case of a rectangular duct cross section, the dimensions are $b_1 \times h_1$.

b The figure is drawn for circular duct cross sections. In the case of a rectangular duct cross section, the dimensions are $b_2 \times h_2$.

NOTE Fan is installed according to installation category D as defined in ISO 5801:1997.

Figure 5 — Test arrangement for simultaneous measurement of inlet and outlet in-duct noise

5.2.6 Requirements for duct dimensions

In all cases, $l_0 = 1$ m.

The distance between the entry plane of the test duct and the measurement plane should be long enough to ensure undisturbed flow conditions at the measurement plane.

$$l_3 \text{ W max. } \begin{cases} 6d_3 \\ 4 \text{ m} \end{cases} \quad l_6 \text{ W max. } \begin{cases} 6d_6 \\ 4 \text{ m} \end{cases}$$

$$l_{m3} \text{ W max. } \begin{cases} 4d_3 \\ 2 \text{ m} \end{cases} \quad l_{m6} \text{ W max. } \begin{cases} 4d_6 \\ 2 \text{ m} \end{cases}$$

<p>For circular fan inlet, d_1</p> $d_1 \cup d_3 \cup \sqrt{2,1}d_1$ $l_1 = d_3$ $l_{31} \text{ Wmax. } \left(\begin{array}{l} d_3 \\ 3,8(d_3 - d_1) \\ \left[(d_3/d_1)^2 - 1 \right] l_0 \end{array} \right)$	<p>For circular fan outlet, d_2</p> $0,95 \cup \left(\frac{d_4}{d_2} \right)^2 \cup 1,07$ $l_{24} \text{ Wmax. } \left(\begin{array}{l} d_4 \\ \left[\left(\frac{d_4}{d_2} \right)^2 - 1 \right] l_0 \text{ if } d_4 > d_2 \\ \left[\left(\frac{d_2}{d_4} \right)^2 - 1 \right] l_0 \text{ if } d_2 > d_4 \end{array} \right)$
<p>For rectangular fan inlet, $b_1 \times h_1$</p> $b_1 \times h_1 \cup \frac{\pi}{4} d_3^2 \cup 2,1(b_1 \times h_1)$ $l_1 = \sqrt{\frac{4b_1h_1}{\pi}}$ $l_{31} \text{ Wmax. } \left(\begin{array}{l} d_3 \\ 3,8 \left \sqrt{b_1^2 + h_1^2} - d_3 \right \\ \left[\frac{\pi d_3^2}{4b_1h_1} - 1 \right] l_0 \end{array} \right)$	<p>For rectangular fan outlet, $b_2 \times h_2$ where $b_2 > h_2$</p> $0,95(b_2 \times h_2) \cup \frac{\pi}{4} d_4^2 \cup 1,07(b_2 \times h_2)$ $l_{24} \text{ W max. } \left(\begin{array}{l} d_4 \text{ when } 1 \cup b_2 \cup \frac{4}{3}h_2 \\ 0,75 \left(\frac{b_2}{h_2} \right) d_4 \text{ when } b_2 \text{ W } \frac{4}{3}h_2 \\ 3,8 \left \sqrt{b_2^2 + h_2^2} - d_4 \right \\ \left[\frac{\pi d_4^2}{4b_2h_2} - 1 \right] l_0 \text{ when } \frac{\pi}{4} d_4^2 > b_2h_2 \\ \left[\frac{4b_2h_2}{\pi d_4^2} - 1 \right] l_0 \text{ when } b_2h_2 > \frac{\pi}{4} d_4^2 \end{array} \right)$
	<p>For circular and rectangular fan outlet</p> $0,7 \cup \left(\frac{d_6}{d_2} \right)^2 \cup 2,1$ $l_{46} \text{ Wmax. } \left(\begin{array}{l} 3,8(d_6 - d_4) \\ \left[\left(\frac{d_6}{d_4} \right)^2 - 1 \right] l_0 \end{array} \right) \text{ for } d_6 > d_4$ $l_{46} \text{ Wmax. } \left(\begin{array}{l} 3,8(d_4 - d_6) \\ \left[\left(\frac{d_4}{d_6} \right)^2 - 1 \right] l_0 \end{array} \right) \text{ for } d_4 > d_6$

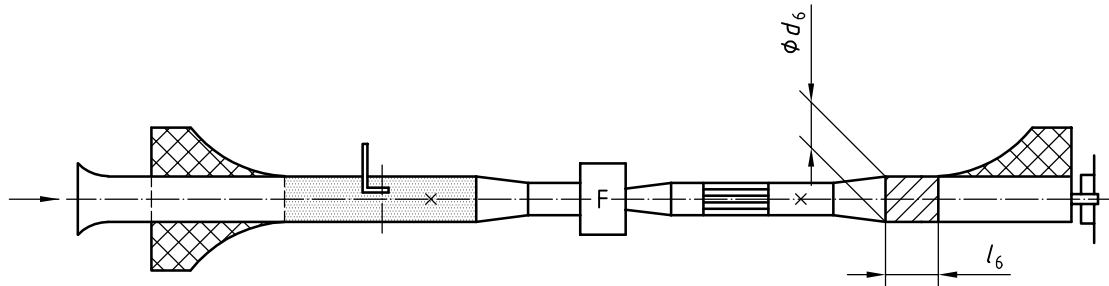

a) Installation category D (simultaneous measurement of aerodynamic performance possible)

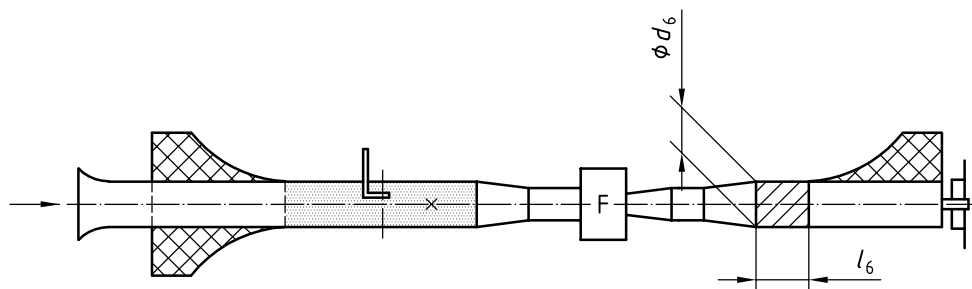

b) Installation category D

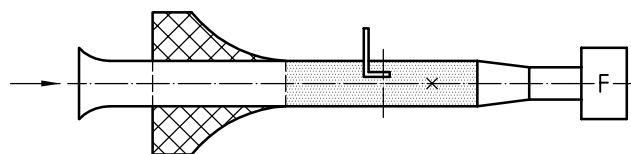

c) Installation category C

NOTE 1 All dimensions are as for Figure 5 except for l_6 : $l_6 \geq d_6$ and $W \geq 1$ m.

NOTE 2 Flow control is at the inlet.

NOTE 3 Fan installation categories are as defined in ISO 5801:1997.

NOTE 4 See Figure 7 for identification of items.

Figure 6 — Test arrangement for measurement of inlet in-duct noise only

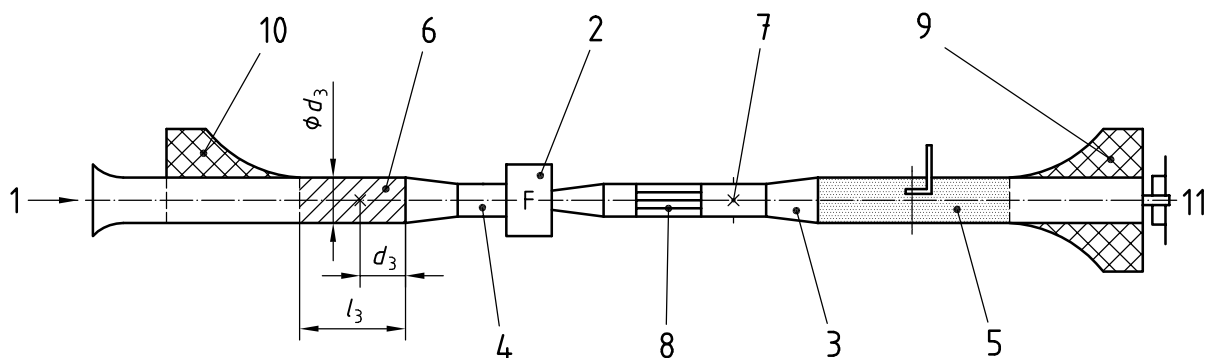

a) Installation category D (simultaneous measurement of aerodynamic performance possible)

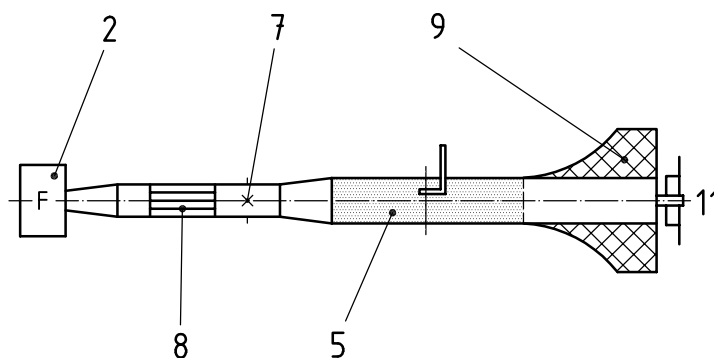

b) Installation category B

Key

- | | |
|---------------------|----------------------------------------------|
| 1 direction of flow | 7 pressure taps |
| 2 fan | 8 star-type (Etoile) flow straightener |
| 3 transition duct | 9 anechoic termination for test duct |
| 4 intermediate duct | 10 anechoic termination for terminating duct |
| 5 test duct | 11 throttle |
| 6 terminating duct | |

NOTE 1 All dimensions are as for Figure 5 except for l_3 : $l_3 \geq 4d_3$ and $W \geq 1$ m.

NOTE 2 Flow control is at the outlet.

NOTE 3 Fan installation categories are as defined in ISO 5801:1997.

Figure 7 — Test arrangement for measurement of outlet in-duct noise only

5.2.7 Anechoic termination

Table 5 shows the maximum permissible values of the pressure reflection coefficient of the anechoic termination, r_a , when a throttling device or a flow measurement device is installed.

Table 5 — Maximum permissible values of the pressure reflection coefficient of the anechoic termination

One-third-octave-band centre frequency Hz	Maximum pressure reflection coefficient	
	Test duct	Terminating duct
50	0,4	0,8
63	0,35	0,7
80	0,3	0,6
100	0,25	0,5
125	0,15	0,3
160	0,15	0,3
> 160	0,15	0,2

NOTE 1 An open duct end of 1,6 m diameter fulfils the maximum pressure reflection coefficient requirements for terminating ducts.

NOTE 2 The anechoic termination for the termination duct is needed only to establish a basically non-reflective acoustic load impedance; no sound pressure measurements are to be made in the terminating duct. Therefore, the maximum permissible pressure reflection coefficient of the anechoic termination of the terminating duct is greater than that of the test duct.

NOTE Guidelines for the design of the anechoic terminations and a method for measuring the pressure reflection coefficient of the termination are given in Annexes E and F.

5.2.8 Throttling device

An adjustable throttling device, if necessary, shall be provided at the end of the anechoic termination remote from the fan. No other throttle shall be placed between the fan and the anechoic termination. The throttling section shall provide control to adjust the operating conditions under which it is desired to determine the sound power of the fan.

The throttling device and the anechoic termination shall be so designed that the sound pressure level generated in the test duct by the throttling device is at least 10 dB below the sound pressure level in the test duct from the fan.

Suggested throttling arrangements are shown in Figure E.8.

5.2.9 Flow straightener

To reduce the swirl energy at the outlet of the fan, a flow straightener should be mounted upstream of the test duct (see Figure 7). The flow straightener is of cylindrical cross section with an internal diameter equal to that of the intermediate duct, diameter d_4 , and an axial length of twice the internal diameter. The flow straightener consists of eight equally spaced radial vanes ("star-type" flow straightener as specified in ISO 5801). The vane thickness shall not exceed 0,007 d_4 .

5.3 Instrumentation

5.3.1 Measuring system

5.3.1.1 Microphone

A microphone of a sound level meter complying with the requirements for a type 1 instrument as specified in IEC 60651:2001 shall be used.

5.3.1.2 Microphone cable

The microphone/cable system shall be such that the sensitivity does not change with temperature in the range prevailing during the test. Cable flexing arising from either microphone traversing or from airflow across the cable shall not introduce noise which interferes with the measurements.

5.3.1.3 Sound level meter or other microphone amplifier

The sound level meter or other amplifier used to amplify the microphone signal shall conform to the electrical requirement for a type 1 sound level meter as specified in IEC 60651:2001.

5.3.2 Frequency analyser

A one-third-octave-band filter set complying with the requirements of IEC 61260 shall be used. The filter band centre frequencies shall be those tabulated in ISO 266.

5.3.3 Sampling tube

5.3.3.1 The sampling tube is designed to reduce the turbulent pressure fluctuations at the measurement positions sufficiently to maintain the signal-to-noise ratio specified in 7.2.1. Design details for fabricating a suitable sampling tube are given in Annex G. Typical values of the turbulence noise suppression obtainable with a well-designed sampling tube are given in Table G.1.

5.3.3.2 The sampling tube and its use shall comply with the following requirements.

- a) In a swirl-free flow, the turbulence noise shall be suppressed by at least 10 dB in the frequency range of interest as compared with a nose cone. The actual values of turbulence noise suppression as a function of frequency and mean flow velocity shall be known in order to determine the signal-to-noise ratio as specified in 7.2.1 (see also Annex B and Table G.1).
- b) The maximum diameter of the sampling tube shall be 22 mm.
- c) The frequency response correction C_2 of the sampling tube for each one-third-octave band of interest shall be determined to within $\pm 0,5$ dB in a plane-wave field incident axially from the front. If tests are carried out in a free field, a minimum distance of 3 m between the loudspeaker and the sampling tube being tested shall be maintained. The reference position for measurements without sampling tube shall be at the mid-point of the sampling tube length. See Figure 8. An individual calibration measurement is necessary for each sampling tube to be used.

The equation for calculating C_2 from such measurements is

$$C_2 = L_{p2} - L_{p1} \quad (5)$$

where

L_{p1} is the sound pressure level measured with the microphone in the sampling tube;

L_{p2} is the sound pressure level measured with the same microphone placed at the reference position.

A manufacturer's individual calibration curve, obtained in compliance with the requirements for the frequency response correction, may be used. It is essential that the frequency response correction curve be smooth. In any one-third-octave band of interest, the frequency response curve shall be smooth to within ± 3 dB when measured with an analyser with a bandwidth of 25 Hz or less.

The porous part of the sampling tube should be clean and undamaged because it affects the frequency response correction C_2 . When the tube is used in dusty environments, its frequency response changes, and frequent calibration is advisable.

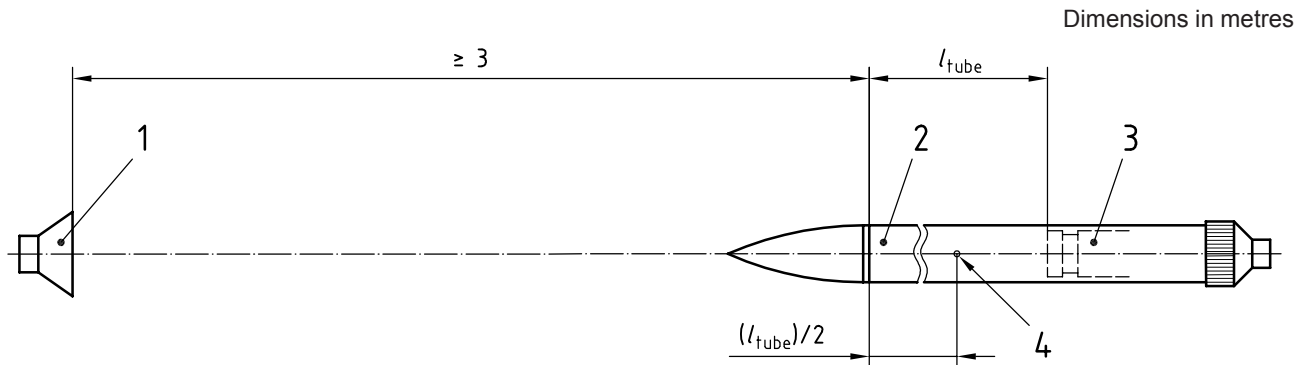

Key

- 1 loudspeaker
- 2 sampling tube
- 3 microphone
- 4 reference position of microphone diaphragm

l_{tube} is the length of the slit.

Figure 8 — Illustration of the reference microphone position

5.3.3.3 The directivity of the sampling tube, when measured in a free field with broad-band noise of one-third-octave bandwidth, shall be within the limits given in Figure 9.

Curves illustrated in Figure 9 are given by the following equation:

$$\Delta L = 20 \lg \frac{1}{1 + f_m \times K \times \theta^3} \text{ dB for } 0 < \theta < 1,31 \text{ rad } (75^\circ) \quad (6)$$

where

- ΔL is the reduction of sensitivity, in decibels, at an incidence angle θ compared with incidence axially from the front [$\theta = 0$ rad (0°)];
- K is the directivity constant;
- f_m is the centre frequency of the one-third-octave band, in hertz;
- θ is the angle of incidence, in radians.

The limiting values of the directivity constant K are given in Table 6.

Table 6 — Limiting values of the directivity constant K

One-third-octave-band centre frequency Hz	K_{\min} 10^{-3}	K_{\max} 10^{-3}
1 000	0,35	1,5
2 000	0,35	1,5
4 000	0,35	2,2
8 000	0,35	2,2

A manufacturer's statement that the sampling tube directivity is within the limits specified by Figure 9 may be used.

5.3.3.4 Values for the mean flow velocity-modal correction $C_{3,4}$ can be calculated with the following equation as a function of the mean flow velocity U (see references [24] and [25]):

$$C_{3,4} = a_0 + a_1U + a_2U^2 + a_3U^3 + a_4U^4 + a_5U^5 + a_6U^6 + a_7U^7 + a_8U^8 + a_9U^9 + a_{10}U^{10} \quad (7)$$

where $U < 0$ for inlet-side measurements and $U > 0$ for outlet-side measurements.

The values of the coefficients a_0 to a_{10} shall be taken from Tables A.1 to A.6.

NOTE In the frequency range covered by this International Standard (i.e. 50 Hz to 10 000 Hz), values for the coefficients a_i are given for the range of flow velocities covered by this International Standard, i.e. $|U| \leq 40$, plus, for information only, for an extended range, $|U| \leq 60$. Also for information only, values are given for an extended frequency range 12 500 Hz to 20 000 Hz for flow velocities $|U| \leq 40$. As an example, $C_{3,4}$ is calculated in Annex D for a test duct with a diameter $d = 0,5$ m for three flow velocities.

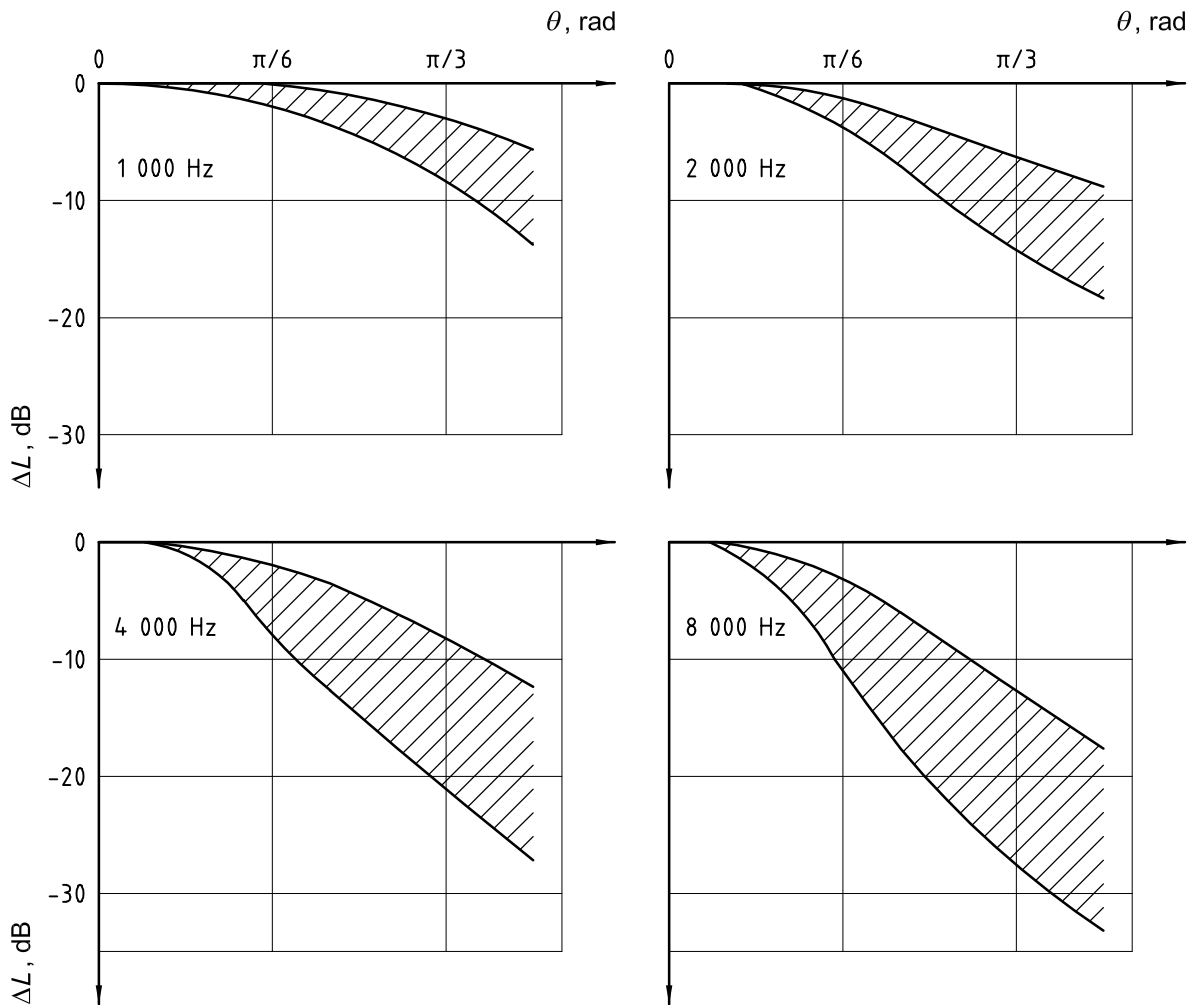

Figure 9 — Limiting curves for the directivity of the sampling tube
 (broad-band noise of one-third-octave bandwidth)

5.3.4 Nose cone and foam ball

5.3.4.1 In many cases of low duct air velocity, the turbulence levels may be sufficiently low to permit the use of a nose cone or foam ball. The sampling tube limits to a greater extent the apparent sound pressure

level caused by turbulent pressure fluctuations in the airstream (which are not propagated as noise). These pressure fluctuations are most likely to cause over-estimation of fan sound in the frequencies covered by the 63 Hz and 125 Hz octave bands. The sampling tube is the preferred device when these bands are of importance.

5.3.4.2 The frequency response correction C_2 of the nose cone or the foam ball for each one-third-octave band of interest shall be determined to within $\pm 0,5$ dB in a plane-wave field incident axially from the front. If tests are carried out in a free field, a minimum distance of 3 m between the loudspeaker and the microphone shield being tested shall be maintained. An individual calibration measurement is necessary for each shield to be used. Alternatively, an individual manufacturer's current calibration curve, obtained in compliance with the requirements for the frequency response correction, shall be used.

5.3.4.3 The nose cone and foam ball combinations are treated as omni-directional.

Data for the combined mean flow velocity and modal correction $C_{3,4}$ are not available for the nose cone and the foam ball. The corrections for these omni-directional microphone shields are estimated to be negative and of small magnitude and are, therefore, considered to be independent of frequency for the purposes of this International Standard. For swirl-free flow, this correction is a function of the mean flow velocity according to the following equation (see references [24] and [25]):

$$C_{3,4} = 10 \lg \frac{1}{\left(1 - \frac{U}{c}\right)^2} \text{ dB} \quad (8)$$

where

U is the mean flow velocity;

$U < 0$ for inlet-side measurements;

$U > 0$ for outlet-side measurements;

c is the speed of sound (under normal conditions, $c = 340$ m/s).

With this simplification, the sound power level obtained by using the nose cone or foam ball is expected to be higher than the true sound power level.

5.3.4.4 The cross-sectional area of the foam ball shall not exceed 10 % of the cross-sectional area of the duct.

5.3.5 Graphic level recorder or other read-out devices

Graphic level recorders and other read-out devices shall comply with the requirements for a type 1 instrument as specified in IEC 60651:2001.

5.3.6 Multiplexing system

If the procedure outlined in 6.2.2 b) is used, the multiplexing system shall be qualified such that the resulting sound pressure level is within $\pm 0,5$ dB of the true energy-equivalent average of the individual sound pressure levels throughout the frequency range of interest.

5.4 System calibration

A sound calibrator of class 1 according to IEC 60942:1997 shall be applied to the microphone without the sampling tube to check the calibration of the entire measuring system before and after each series of tests. The calibrator shall be recalibrated annually.

6 Test arrangement

6.1 Sampling tube mounting

The microphone with the sampling tube shall be mounted in the test duct in the measuring plane as shown in Figure 5. The sampling tube shall be vibration-isolated from the test duct wall to prevent structure-borne noise from reaching the microphone through the probe support. A tail may be needed on the microphone probe, behind the support arm, extending away from the turbulence screen.

The microphone with the sampling tube shall be mounted securely in an axial direction, aligned to within $\pm 5^\circ$ of the test duct centreline and pointing toward the fan. For fan inlet measurements, the sampling tube shall point toward the fan, but the microphone end of the tube shall be rounded. The mounting shall introduce a minimum of airflow noise and, insofar as possible, the microphone cable shall be kept out of the airstream.

NOTE Schematic drawings of typical mountings are given in Annex G.

6.2 Microphone position

6.2.1 Radial microphone position

The microphone shall be mounted at the radial positions given in Table 7 and shown in Figure 10 (r is the radial distance from the duct axis).

Table 7 — Radial positions of the microphone

Values in metres

Test duct diameter d	Relative radial position from the duct axis $2 r/d$	
	Microphone with sampling tube	Microphone with foam ball or nose cone
$0,15 \leq d < 0,5$	0,8	0,5
$0,5 \leq d \leq 2$	0,65	0,5

NOTE The given radial positions ensure a good estimate of the sound power from the measured sound pressure.

6.2.2 Circumferential positions

At the radial positions specified in 6.2.1, a circumferential mean value of the sound pressure level shall be obtained by using one of the following procedures.

- A single microphone is moved sequentially to at least three microphone positions distributed equally on the circumference. This may be achieved by fixing the microphone in a short duct section which can be rotated in equal intervals.
- Three or more fixed microphones are evenly distributed on the circumference. If the signals of these microphones are to be averaged using a multiplexing system, they shall have the same type of sampling tube fitted and their sensitivities shall be equalised to ensure that they have equal frequency response corrections to within 0,5 dB.
- One microphone is moved with a continuous circumferential traverse at constant angular velocity through one complete revolution.

If the porous part of the sampling tube consists of one slit only, this slit shall be located in the circumferential direction opposite to the incidence of the swirl component. (See Figure 10.)

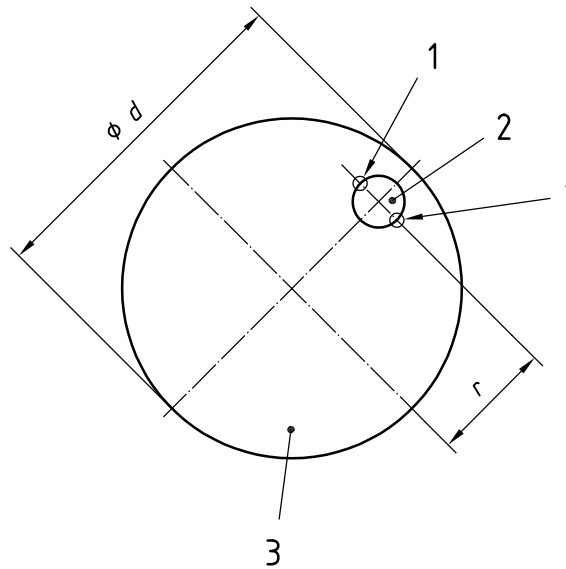

Key

- 1 possible positions of the slit of a sampling tube
- 2 microphone
- 3 test duct

NOTE The slit should face away from the direction of the swirl component of the flow.

Figure 10 — Radial position of the microphone and microphone shield

6.3 Operating condition control equipment

The equipment specified in 5.1 and 5.2.8 used to control the operating conditions shall not interfere with the acoustical measurements (see 7.2.1).

7 Test procedure

7.1 Operating conditions

The operating conditions shall be determined by the procedures which are specified in ISO 5801.

7.2 Sound pressure level readings

7.2.1 General

Measurements shall be made in one-third-octave bands within the frequency range of interest.

Sound pressure level readings shall be taken under the required steady-state operating conditions of the fan. The sound pressure level readings in each one-third-octave band with the fan running shall be at least 6 dB above the background noise levels. The background noise levels should be measured with the fan under test inoperative. If the background noise level is less than 6 dB below the sound pressure level, the data shall be reported as measured and no correction for background noise shall be made. A note shall be added that states "Not more than 6 dB above the level of background noise, and no correction for background noise was made".

The fan sound pressure level readings in each one-third-octave band shall be at least 6 dB above the level of the pressure fluctuations which are associated with the turbulent flow in the test duct. One of the two

procedures for determining this signal-to-noise ratio specified in Annex B shall be used. Where the fan sound pressure level is less than 6 dB above the level of the turbulent pressure fluctuations, the data shall be reported as measured and no correction for turbulent pressure fluctuations shall be made. A note shall be added that states "Not more than 6 dB above the level of turbulent pressure fluctuations, and no correction for turbulent pressure fluctuations was made."

7.2.2 Sampling time

At each one of the three measurement positions described in 6.2.2 [see procedure outlined in a) or b)], an energy-equivalent time-averaged sound pressure level shall be obtained. For frequency bands centred at or below 160 Hz, the period of observation shall be at least 30 s. For the frequency bands centred at or above 200 Hz, the period of observation shall be at least 10 s. Longer observation periods may be required if the measured sound varies with time. The average sound pressure level shall be recorded to the nearest 0,1 dB for each one-third-octave band within the frequency range of interest.

7.2.3 Microphone multiplexing

If microphone multiplexing is used [see procedure outlined in 6.2.2. b)], it is only necessary to record the temporally and spatially averaged sound pressure level (energy-equivalent level) L_{pm} for each one-third-octave band within the frequency range of interest. The minimum averaging time shall be 30 s for each band.

7.2.4 Continuous circumferential average

A circumferential traverse [see procedure outlined in 6.2.2 c)], if used, shall be such that the microphone is moved through one revolution in 30 s or more, at constant angular velocity, for each one-third-octave band.

7.3 Measurements with and without flow straightener on the outlet side

The presence of the flow straightener on the fan outlet side is necessary for the measurement of the aerodynamic fan performance according to ISO 5801. Two effects shall be considered when performing the sound measurement in the outlet duct:

- a) the swirling flow entering the flow straightener can generate excess noise at the measurement station, which may or may not be of higher level than the sound pressure level produced by the fan under test;
- b) without a flow straightener in place, the swirling flow around the measurement microphone can generate excess flow noise, which may or may not be of higher level than the sound pressure level produced by the fan under test.

Both effects tend to increase the measured pressure level over the sound pressure level produced by the fan under test. Which of the two effects is stronger, depends on the amount of swirl, the mean flow velocity in the duct, the microphone shield used, and the acoustic strength of the source under test. Therefore, the outlet duct noise shall be measured with and without the star straightener in position. Of the sound pressure level readings taken, the lowest shall be considered to represent the true sound pressure in the test duct, for each one-third-octave band of interest.

The sound measurements with and without the flow straightener shall be made at the same operating point of the fan. This may be achieved by setting the flow control device in such a way that the flow rate delivered by the fan under test is the same in both configurations.

7.4 Inlet side measurements — Large fans: installation category D (according to ISO 5801:1997)

For large fans (1 600 mm and larger) it may be difficult to carry out the tests with the standardized common part on the outlet side, including the straightener. In this case, the fan performance may be measured with a duct of $2D_h$ in length on the outlet side and restricting sound measurements to the inlet side. Results obtained in this way can differ to some extent from those obtained by using common airways on both the inlet and outlet sides, especially if the fan produces a large swirl.

NOTE The hydraulic diameter of the fan outlet area, S_{f2} , is given by

$$D_h = \sqrt{S_{f2}/\pi}$$

8 Calculations

8.1 Average sound pressure level

Where measurements of sound pressure level are made at discrete positions (see 6.2.2), the average sound pressure level, $\overline{L_p}$, in decibels, for each frequency band shall be calculated using the formula

$$\overline{L_p} = 10 \lg \left[\frac{1}{n} \sum_{i=1}^n 10^{0,1L_{pi}} \right] \text{ dB} + C \quad (9)$$

where

n is the number of measurement positions (at least three; see 6.2.2);

L_{pi} is the time-averaged sound pressure level, in decibels, at the i th measurement position;

C is the combined frequency response correction of the microphone sampling tube combination and is given by the formula

$$C = C_1 + C_2 + C_{3,4} \quad (10)$$

where

C_1 is the microphone response correction;

C_2 is the frequency response correction of the microphone shield;

$C_{3,4}$ is the mean flow velocity — modal correction of the microphone shield.

C_1 shall be taken from the microphone manufacturer's data.

C_2 and $C_{3,4}$ shall be determined in accordance with the requirements of 5.3.3 and 5.3.4.

If microphone multiplexing (see 7.2.3) or a continuous circumferential traverse (see 7.2.4) is used to obtain $\overline{L_{pm}}$, the average sound pressure level for each frequency band is calculated from the formula

$$\overline{L_p} = \overline{L_{pm}} + C \quad (11)$$

8.2 Sound power level

The sound power level, L_W , in decibels, of the sound radiated into the test duct for each frequency band is obtained by using the plane-wave formula

$$L_W = \overline{L_p} + \left(10 \lg \frac{S}{S_0} - 10 \lg \frac{\rho c}{(\rho c)_0} \right) \text{ dB} \quad (12)$$

where

$S = \frac{\pi d^2}{4}$ is the cross-sectional area of the test duct, in square metres;

$S_0 = 1 \text{ m}^2$;

$$(\rho c)_0 = 400 \text{ N} \cdot \text{s/m}^3$$

The A-weighted sound power level of the sound radiated into the test duct shall be determined in accordance with Annex C.

9 Information to be recorded

9.1 The following information, when applicable, shall be compiled and recorded for all measurements made in accordance with the requirements of this International Standard:

- a) a description of the fan under test and its accessories;
- b) the operating conditions;
- c) the instrumentation used (types, serial numbers, manufacturers, method of calibration);
- d) type of microphone shield used (sampling tube, nose cone or foam ball);
- e) a description of the ducts used, including lengths and cross-sectional areas (or diameters), and description of the anechoic termination(s);
- f) acoustical data
 - circumferential positions of the microphone in accordance with options a), b) or c) given in 6.2.2,
 - corrections C_1 , C_2 , $C_{3,4}$ and sound power levels in one-third-octave bands within the frequency range of interest, and
 - A-weighted sound power level, if required;
- g) any mutually agreed options.

9.2 Unless more specific knowledge is available, the expanded measurement uncertainty for a coverage of 95 % shall be recorded to be twice the standard deviation of reproducibility as given in Clause 4.

10 Information to be reported

The test report shall contain the statement that the sound power levels have been obtained in compliance with the requirements of this International Standard. The report shall state that the sound power levels are given in decibels (with the reference sound power being 1 pW).

Furthermore, the information from 9 a) to d) and 9 g) shall be given.

It is recommended to include a statement on the measurement uncertainty in accordance with 9.2.

Annex A (normative)

Determination of the combined mean flow velocity and modal correction $C_{3,4}$

For detailed information on the calculation of $C_{3,4}$ see references [24] and [25].

See Tables A.1 to A.6 for the values of a_i .

Table A.1 — Values of coefficients a_i for the determination of the combined mean flow velocity and modal correction $C_{3,4}$ of the sampling tube for duct diameters $0,15 \text{ m} \leq d < 0,2 \text{ m}$

$a_i, \text{ dB}\cdot\text{s}^i\cdot\text{m}^{-i}$											
$f, \text{ Hz}$	a_0	a_1	a_2	a_3	a_4	a_5	a_6	a_7	a_8	a_9	a_{10}
$ U \leq 60 \text{ m/s}^*$											
630	$-5,00 \times 10^{-02}$	$2,70 \times 10^{-02}$									
800		$2,97 \times 10^{-02}$									
1 000	$-2,09 \times 10^{-02}$	$2,85 \times 10^{-02}$	$1,18 \times 10^{-04}$								
1 250	$8,41 \times 10^{-01}$	$3,61 \times 10^{-02}$	$9,34 \times 10^{-05}$								
1 600	$7,79 \times 10^{-01}$	$5,01 \times 10^{-02}$	$1,38 \times 10^{-04}$								
2 000	$7,67 \times 10^{-01}$	$5,45 \times 10^{-02}$	$3,77 \times 10^{-04}$								
2 500	1,59	$6,12 \times 10^{-02}$	$5,06 \times 10^{-04}$								
3 150	2,40	$8,26 \times 10^{-02}$	$7,45 \times 10^{-04}$	$-3,02 \times 10^{-06}$							
4 000	3,43	$9,99 \times 10^{-02}$	$9,61 \times 10^{-04}$	$-3,29 \times 10^{-06}$							
5 000	3,98	$1,29 \times 10^{-01}$	$2,21 \times 10^{-03}$	$-8,88 \times 10^{-06}$	$-2,32 \times 10^{-07}$						
6 300	4,87	$1,59 \times 10^{-01}$	$3,43 \times 10^{-03}$	$-1,73 \times 10^{-05}$	$-5,12 \times 10^{-07}$						
8 000	6,09	$2,04 \times 10^{-01}$	$6,57 \times 10^{-03}$	$-5,09 \times 10^{-05}$	$-2,47 \times 10^{-06}$	$5,89 \times 10^{-09}$	$3,32 \times 10^{-10}$				
10 000	6,95	$2,54 \times 10^{-01}$	$1,12 \times 10^{-02}$	$-1,19 \times 10^{-04}$	$-7,88 \times 10^{-06}$	$3,39 \times 10^{-08}$	$2,52 \times 10^{-09}$	$-3,22 \times 10^{-12}$	$-2,85 \times 10^{-13}$		
$ U \leq 40 \text{ m/s}$											
12 500	8,06	$3,04 \times 10^{-01}$	$1,68 \times 10^{-02}$	$-2,06 \times 10^{-04}$	$-1,59 \times 10^{-05}$	$6,99 \times 10^{-08}$	$5,07 \times 10^{-09}$				
16 000	9,25	$3,71 \times 10^{-01}$	$2,75 \times 10^{-02}$	$-4,42 \times 10^{-04}$	$-4,90 \times 10^{-05}$	$3,74 \times 10^{-07}$	$3,73 \times 10^{-08}$	$-1,06 \times 10^{-10}$	$-9,89 \times 10^{-12}$		
20 000	$1,06 \times 10^{+01}$	$4,46 \times 10^{-01}$	$4,08 \times 10^{-02}$	$-7,79 \times 10^{-04}$	$-1,21 \times 10^{-04}$	$1,25 \times 10^{-06}$	$1,63 \times 10^{-07}$	$-8,86 \times 10^{-10}$	$-9,97 \times 10^{-11}$	$2,21 \times 10^{-13}$	$2,25 \times 10^{-14}$
Where an empty cell occurs in the table, the respective value of a_i shall be taken as zero.											
NOTE Compute the value of $C_{3,4}$ from the approximation											
$C_{3,4}(U) = \sum_{i=0}^{10} a_i U^i$											
where U is the mean flow velocity in metres per second. $U < 0$ for the inlet duct and $U > 0$ for the outlet duct.											
* In the frequency range covered by this International Standard (i.e. 50 Hz to 10 000 Hz), values for the coefficients a_i are given for the range of flow velocities covered by this International Standard, i.e. $ U \leq 40$, plus, for information only, for an extended range, $ U \leq 60$. Also for information only, values are given for an extended frequency range, 12 500 Hz to 20 000 Hz, for flow velocities $ U \leq 40$.											

Table A.2 — Values of coefficients a_i for the determination of the combined mean flow velocity and modal correction $C_{3,4}$ of the sampling tube for duct diameters $0,2 \text{ m} \leq d < 0,3 \text{ m}$

$a_i, \text{dB}\cdot\text{s}^i\cdot\text{m}^{-i}$											
f, Hz	a_0	a_1	a_2	a_3	a_4	a_5	a_6	a_7	a_8	a_9	a_{10}
$ U \leq 60 \text{ m/s}^*$											
630	$-5,00 \times 10^{-02}$	$2,70 \times 10^{-02}$									
800	$1,36 \times 10^{-01}$	$3,30 \times 10^{-02}$									
1 000	$1,75 \times 10^{-01}$	$4,08 \times 10^{-02}$									
1 250	$-3,32 \times 10^{-02}$	$4,32 \times 10^{-02}$	$1,35 \times 10^{-04}$								
1 600	$5,43 \times 10^{-01}$	$4,92 \times 10^{-02}$	$1,89 \times 10^{-04}$								
2 000	1,29	$5,80 \times 10^{-02}$	$3,01 \times 10^{-04}$								
2 500	1,91	$6,93 \times 10^{-02}$	$4,60 \times 10^{-04}$								
3 150	2,64	$9,00 \times 10^{-02}$	$8,73 \times 10^{-04}$	$-4,13 \times 10^{-06}$							
4 000	3,88	$1,07 \times 10^{-01}$	$1,15 \times 10^{-03}$	$-6,03 \times 10^{-06}$							
5 000	4,50	$1,29 \times 10^{-01}$	$2,55 \times 10^{-03}$	$-1,03 \times 10^{-05}$	$-2,75 \times 10^{-07}$						
6 300	5,54	$1,52 \times 10^{-01}$	$3,93 \times 10^{-03}$	$-1,68 \times 10^{-05}$	$-6,36 \times 10^{-07}$						
8 000	6,85	$1,89 \times 10^{-01}$	$7,37 \times 10^{-03}$	$-4,51 \times 10^{-05}$	$-3,13 \times 10^{-06}$	$6,10 \times 10^{-09}$	$4,34 \times 10^{-10}$				
10 000	7,82	$2,29 \times 10^{-01}$	$1,17 \times 10^{-02}$	$-8,27 \times 10^{-05}$	$-9,21 \times 10^{-06}$	$2,52 \times 10^{-08}$	$3,00 \times 10^{-09}$	$-2,62 \times 10^{-12}$	$-3,39 \times 10^{-13}$		
$ U \leq 40 \text{ m/s}$											
12 500	9,04	$2,75 \times 10^{-01}$	$1,56 \times 10^{-02}$	$-1,07 \times 10^{-04}$	$-1,70 \times 10^{-05}$	$3,13 \times 10^{-08}$	$5,71 \times 10^{-09}$				
16 000	$1,02 \times 10^{+01}$	$3,49 \times 10^{-01}$	$2,26 \times 10^{-02}$	$-1,94 \times 10^{-04}$	$-4,60 \times 10^{-05}$	$1,05 \times 10^{-07}$	$3,74 \times 10^{-08}$	$-2,33 \times 10^{-11}$	$-1,02 \times 10^{-11}$		
20 000	$1,18 \times 10^{+01}$	$4,59 \times 10^{-01}$	$1,81 \times 10^{-02}$	$-4,24 \times 10^{-04}$	$-3,60 \times 10^{-05}$	$3,70 \times 10^{-07}$	$3,06 \times 10^{-08}$	$-1,94 \times 10^{-10}$	$-8,76 \times 10^{-12}$	$4,09 \times 10^{-14}$	
Where an empty cell occurs in the table, the respective value of a_i shall be taken as zero.											
NOTE Compute the value of $C_{3,4}$ from the approximation											
$C_{3,4}(U) = \sum_{i=0}^{10} a_i U^i$											
where U is the mean flow velocity in metres per second. $U < 0$ for the inlet duct and $U > 0$ for the outlet duct.											
* In the frequency range covered by this International Standard (i.e. 50 Hz to 10 000 Hz), values for the coefficients a_i are given for the range of flow velocities covered by this International Standard, i.e. $ U \leq 40$, plus, for information only, for an extended range, $ U \leq 60$. Also for information only, values are given for an extended frequency range, 12 500 Hz to 20 000 Hz, for flow velocities $ U \leq 40$.											

Table A.3 — Values of coefficients a_i for the determination of the combined mean flow velocity and modal correction $C_{3,4}$ of the sampling tube for duct diameters 0,3 m \cup $d < 0,5$ m

$a_i, \text{dB}\cdot\text{s}^i\cdot\text{m}^{-i}$											
f, Hz	a_0	a_1	a_2	a_3	a_4	a_5	a_6	a_7	a_8	a_9	a_{10}
$ U \cup 60 \text{ m/s}^*$											
$\cup 400$	$-5,00 \times 10^{-02}$	$2,70 \times 10^{-02}$									
500	$-3,91 \times 10^{-01}$	$3,13 \times 10^{-02}$									
630	$-6,13 \times 10^{-01}$	$3,32 \times 10^{-02}$									
800	$-4,78 \times 10^{-01}$	$3,57 \times 10^{-02}$									
1 000	$-2,06 \times 10^{-01}$	$4,07 \times 10^{-02}$									
1 250	$3,80 \times 10^{-01}$	$4,71 \times 10^{-02}$	$8,89 \times 10^{-05}$								
1 600	$8,58 \times 10^{-01}$	$5,33 \times 10^{-02}$	$1,87 \times 10^{-04}$								
2 000	1,58	$6,06 \times 10^{-02}$	$3,34 \times 10^{-04}$								
2 500	2,46	$7,49 \times 10^{-02}$	$5,64 \times 10^{-04}$	$-3,11 \times 10^{-06}$							
3 150	3,51	$8,64 \times 10^{-02}$	$9,06 \times 10^{-04}$	$-4,39 \times 10^{-06}$							
4 000	4,75	$9,80 \times 10^{-02}$	$1,69 \times 10^{-03}$	$-4,85 \times 10^{-06}$	$-1,45 \times 10^{-07}$						
5 000	5,62	$1,14 \times 10^{-01}$	$2,59 \times 10^{-03}$	$-4,34 \times 10^{-06}$	$-3,56 \times 10^{-07}$						
6 300	6,77	$1,44 \times 10^{-01}$	$3,17 \times 10^{-03}$	$-6,85 \times 10^{-06}$	$-6,10 \times 10^{-07}$						
8 000	8,09	$1,88 \times 10^{-01}$	$4,88 \times 10^{-03}$	$-1,37 \times 10^{-05}$	$-2,27 \times 10^{-06}$	$-1,03 \times 10^{-09}$	$3,36 \times 10^{-10}$				
10 000	9,12	$2,59 \times 10^{-01}$	$4,51 \times 10^{-03}$	$-6,07 \times 10^{-05}$	$-2,12 \times 10^{-06}$	$7,03 \times 10^{-09}$	$3,47 \times 10^{-10}$				
$ U \cup 40 \text{ m/s}$											
12 500	9,84	$3,38 \times 10^{-01}$	$7,94 \times 10^{-03}$	$-1,53 \times 10^{-04}$	$-7,19 \times 10^{-06}$	$3,21 \times 10^{-08}$	$2,40 \times 10^{-09}$				
16 000	$1,08 \times 10^{+01}$	$4,47 \times 10^{-01}$	$9,42 \times 10^{-03}$	$-4,61 \times 10^{-04}$	$-7,86 \times 10^{-06}$	$3,02 \times 10^{-07}$	$2,35 \times 10^{-09}$	$-6,92 \times 10^{-11}$			
20 000	$1,17 \times 10^{+01}$	$5,24 \times 10^{-01}$	$1,74 \times 10^{-02}$	$-7,12 \times 10^{-04}$	$-2,95 \times 10^{-05}$	$6,27 \times 10^{-07}$	$2,18 \times 10^{-08}$	$-1,91 \times 10^{-10}$	$-5,64 \times 10^{-12}$		
Where an empty cell occurs in the table, the respective value of a_i shall be taken as zero.											
NOTE Compute the value of $C_{3,4}$ from the approximation											
$C_{3,4}(U) = \sum_{i=0}^{10} a_i U^i$											
where U is the mean flow velocity in metres per second. $U < 0$ for the inlet duct and $U > 0$ for the outlet duct.											
* In the frequency range covered by this International Standard (i.e. 50 Hz to 10 000 Hz), values for the coefficients a_i are given for the range of flow velocities covered by this International Standard, i.e. $ U \cup 40$, plus, for information only, for an extended range, $ U \cup 60$. Also for information only, values are given for an extended frequency range, 12 500 Hz to 20 000 Hz, for flow velocities $ U \cup 40$.											

Table A.4 — Values of coefficients a_i for the determination of the combined mean flow velocity and modal correction $C_{3,4}$ of the sampling tube for duct diameters $0,5 \text{ m} \leq d < 0,8 \text{ m}$

$a_i, \text{dB}\cdot\text{s}^i\cdot\text{m}^{-i}$											
f, Hz	a_0	a_1	a_2	a_3	a_4	a_5	a_6	a_7	a_8	a_9	a_{10}
$ U \geq 60 \text{ m/s}^*$											
≤ 250	$-5,00 \times 10^{-02}$	$2,70 \times 10^{-02}$									
315	$-6,50 \times 10^{-01}$	$2,89 \times 10^{-02}$									
400	$-4,36 \times 10^{-01}$	$3,01 \times 10^{-02}$									
500	$-3,12 \times 10^{-01}$	$3,09 \times 10^{-02}$									
630	$8,52 \times 10^{-02}$	$3,24 \times 10^{-02}$									
800	1,03	$3,57 \times 10^{-02}$									
1 000	1,85	$3,80 \times 10^{-02}$									
1 250	2,61	$4,34 \times 10^{-02}$	$1,08 \times 10^{-04}$								
1 600	3,18	$5,30 \times 10^{-02}$	$1,32 \times 10^{-04}$								
2 000	3,64	$6,67 \times 10^{-02}$	$1,57 \times 10^{-04}$								
2 500	4,12	$8,36 \times 10^{-02}$	$2,72 \times 10^{-04}$								
3 150	4,64	$1,12 \times 10^{-01}$	$6,78 \times 10^{-04}$	$-6,27 \times 10^{-06}$							
4 000	5,47	$1,30 \times 10^{-01}$	$1,29 \times 10^{-03}$	$-8,74 \times 10^{-06}$	$-1,48 \times 10^{-07}$						
5 000	6,03	$1,53 \times 10^{-01}$	$1,91 \times 10^{-03}$	$-1,17 \times 10^{-05}$	$-2,80 \times 10^{-07}$						
6 300	6,92	$1,84 \times 10^{-01}$	$2,37 \times 10^{-03}$	$-1,99 \times 10^{-05}$	$-3,93 \times 10^{-07}$						
8 000	8,01	$2,34 \times 10^{-01}$	$4,22 \times 10^{-03}$	$-5,79 \times 10^{-05}$	$-1,74 \times 10^{-06}$	$7,63 \times 10^{-09}$	$2,46 \times 10^{-10}$				
10 000	8,90	$2,96 \times 10^{-01}$	$4,86 \times 10^{-03}$	$-1,37 \times 10^{-04}$	$-2,16 \times 10^{-06}$	$4,39 \times 10^{-08}$	$3,29 \times 10^{-10}$	$-5,11 \times 10^{-12}$			
$ U \geq 40 \text{ m/s}$											
12 500	9,57	$3,58 \times 10^{-01}$	$9,87 \times 10^{-03}$	$-2,20 \times 10^{-04}$	$-9,71 \times 10^{-06}$	$7,05 \times 10^{-08}$	$3,25 \times 10^{-09}$				
16 000	$1,05 \times 10^{+01}$	$4,50 \times 10^{-01}$	$1,57 \times 10^{-02}$	$-5,09 \times 10^{-04}$	$-2,78 \times 10^{-05}$	$3,98 \times 10^{-07}$	$2,21 \times 10^{-08}$	$-1,12 \times 10^{-10}$	$-6,07 \times 10^{-12}$		
20 000	$1,17 \times 10^{+01}$	$5,58 \times 10^{-01}$	$1,70 \times 10^{-02}$	$-1,01 \times 10^{-03}$	$-2,93 \times 10^{-05}$	$1,40 \times 10^{-06}$	$2,26 \times 10^{-08}$	$-9,09 \times 10^{-10}$	$-6,11 \times 10^{-12}$	$2,17 \times 10^{-13}$	

Where an empty cell occurs in the table, the respective value of a_i shall be taken as zero.

NOTE Compute the value of $C_{3,4}$ from the approximation

$$C_{3,4}(U) = \sum_{i=0}^{10} a_i U^i$$

where U is the mean flow velocity in metres per second. $U < 0$ for the inlet duct and $U > 0$ for the outlet duct.

* In the frequency range covered by this International Standard (i.e. 50 Hz to 10 000 Hz), values for the coefficients a_i are given for the range of flow velocities covered by this International Standard, i.e. $|U| \geq 40$, plus, for information only, for an extended range, $|U| \geq 60$. Also for information only, values are given for an extended frequency range, 12 500 Hz to 20 000 Hz, for flow velocities $|U| \geq 40$.

Table A.5 — Values of coefficients a_i for the determination of the combined mean flow velocity and modal correction $C_{3,4}$ of the sampling tube for duct diameters $0,8 \text{ m} \leq d < 1,25 \text{ m}$

$f, \text{ Hz}$	$a_i, \text{ dB}\cdot\text{s}^i\cdot\text{m}^{-i}$										
	a_0	a_1	a_2	a_3	a_4	a_5	a_6	a_7	a_8	a_9	a_{10}
$ U \geq 60 \text{ m/s}^*$											
≤ 160	$-5,00 \times 10^{-02}$	$2,70 \times 10^{-02}$									
200	-1,04	$2,35 \times 10^{-02}$									
250	$-7,07 \times 10^{-01}$	$2,62 \times 10^{-02}$									
315	$-5,60 \times 10^{-01}$	$2,87 \times 10^{-02}$									
400	$-1,10 \times 10^{-01}$	$3,01 \times 10^{-02}$									
500	$6,61 \times 10^{-01}$	$3,09 \times 10^{-02}$									
630	1,34	$3,23 \times 10^{-02}$									
800	1,92	$3,72 \times 10^{-02}$									
1 000	2,10	$4,33 \times 10^{-02}$									
1 250	2,26	$5,37 \times 10^{-02}$									
1 600	2,50	$6,30 \times 10^{-02}$	$1,33 \times 10^{-04}$								
2 000	3,00	$7,07 \times 10^{-02}$	$2,66 \times 10^{-04}$								
2 500	3,70	$8,07 \times 10^{-02}$	$3,91 \times 10^{-04}$								
3 150	4,45	$1,05 \times 10^{-01}$	$6,32 \times 10^{-04}$	$-4,55 \times 10^{-06}$							
4 000	5,53	$1,28 \times 10^{-01}$	$8,01 \times 10^{-04}$	$-7,67 \times 10^{-06}$							
5 000	6,00	$1,54 \times 10^{-01}$	$1,74 \times 10^{-03}$	$-,24 \times 10^{-05}$	$-2,32 \times 10^{-07}$						
6 300	6,88	$1,92 \times 10^{-01}$	$2,33 \times 10^{-03}$	$-3,11 \times 10^{-05}$	$-3,94 \times 10^{-07}$	$2,69 \times 10^{-09}$					
8 000	7,97	$2,37 \times 10^{-01}$	$4,25 \times 10^{-03}$	$-5,96 \times 10^{-05}$	$-1,78 \times 10^{-06}$	$7,91 \times 10^{-09}$	$2,57 \times 10^{-10}$				
10 000	8,67	$2,97 \times 10^{-01}$	$6,89 \times 10^{-03}$	$-1,35 \times 10^{-04}$	$-5,29 \times 10^{-06}$	$4,27 \times 10^{-08}$	$1,81 \times 10^{-09}$	$-4,89 \times 10^{-12}$	$-2,15 \times 10^{-13}$		
$ U \geq 40 \text{ m/s}$											
12 500	9,56	$3,59 \times 10^{-01}$	$9,71 \times 10^{-03}$	$-2,22 \times 10^{-04}$	$-9,55 \times 10^{-06}$	$7,20 \times 10^{-08}$	$3,21 \times 10^{-09}$				
16 000	$1,05 \times 10^{+01}$	$4,51 \times 10^{-01}$	$1,56 \times 10^{-02}$	$-5,09 \times 10^{-04}$	$-2,76 \times 10^{-05}$	$3,97 \times 10^{-07}$	$2,19 \times 10^{-08}$	$-1,11 \times 10^{-10}$	$-6,00 \times 10^{-12}$		
20 000	$1,17 \times 10^{+01}$	$5,60 \times 10^{-01}$	$1,68 \times 10^{-02}$	$-1,02 \times 10^{-03}$	$-2,88 \times 10^{-05}$	$1,42 \times 10^{-06}$	$2,22 \times 10^{-08}$	$-9,29 \times 10^{-10}$	$-5,98 \times 10^{-12}$	$2,23 \times 10^{-13}$	
Where an empty cell occurs in the table, the respective value of a_i shall be taken as zero.											
NOTE Compute the value of $C_{3,4}$ from the approximation											
$C_{3,4}(U) = \sum_{i=0}^{10} a_i U^i$											
where U is the mean flow velocity in metres per second. $U < 0$ for the inlet duct and $U > 0$ for the outlet duct.											
* In the frequency range covered by this International Standard (i.e. 50 Hz to 10 000 Hz), values for the coefficients a_i are given for the range of flow velocities covered by this International Standard, i.e. $ U \geq 40$, plus, for information only, for an extended range, $ U \geq 60$. Also for information only, values are given for an extended frequency range, 12 500 Hz to 20 000 Hz, for flow velocities $ U \geq 40$.											

Table A.6 — Values of coefficients a_i for the determination of the combined mean flow velocity and modal correction $C_{3,4}$ of the sampling tube for duct diameters 1,25 m $\leq d \leq$ 2 m

f , Hz	a_i , dB·s ^{i} ·m ^{$-i$}										
	a_0	a_1	a_2	a_3	a_4	a_5	a_6	a_7	a_8	a_9	a_{10}
$ U \leq 60$ m/s											
≤ 100	$-5,00 \times 10^{-02}$	$2,70 \times 10^{-02}$									
125	$-1,24 \times 10^{+00}$	$2,05 \times 10^{-02}$									
160	$-9,02 \times 10^{-01}$	$2,28 \times 10^{-02}$									
200	$-8,46 \times 10^{-01}$	$2,42 \times 10^{-02}$									
250	$-3,52 \times 10^{-01}$	$2,64 \times 10^{-02}$									
315	$4,54 \times 10^{-01}$	$2,85 \times 10^{-02}$									
400	1,15	$3,02 \times 10^{-02}$									
500	1,37	$3,15 \times 10^{-02}$									
630	1,11	$3,45 \times 10^{-02}$									
800	$9,80 \times 10^{-01}$	$4,11 \times 10^{-02}$									
1 000	1,28	$4,53 \times 10^{-02}$									
1 250	1,87	$5,17 \times 10^{-02}$									
1 600	2,31	$6,08 \times 10^{-02}$	$1,33 \times 10^{-04}$								
2 000	2,88	$7,08 \times 10^{-02}$	$2,39 \times 10^{-04}$								
2 500	3,59	$8,22 \times 10^{-02}$	$3,70 \times 10^{-04}$								
3 150	4,37	$1,06 \times 10^{-01}$	$5,76 \times 10^{-04}$	$-4,46 \times 10^{-06}$							
4 000	5,46	$1,27 \times 10^{-01}$	$7,93 \times 10^{-04}$	$-7,43 \times 10^{-06}$							
5 000	5,95	$1,55 \times 10^{-01}$	$1,73 \times 10^{-03}$	$-1,27 \times 10^{-05}$	$-2,32 \times 10^{-07}$						
6 300	6,84	$1,93 \times 10^{-01}$	$2,32 \times 10^{-03}$	$-3,10 \times 10^{-05}$	$-3,93 \times 10^{-07}$	$2,62 \times 10^{-09}$					
8 000	7,95	$2,38 \times 10^{-01}$	$4,21 \times 10^{-03}$	$-6,04 \times 10^{-05}$	$-1,77 \times 10^{-06}$	$8,08 \times 10^{-09}$	$2,56 \times 10^{-10}$				
10 000	8,85	$2,97 \times 10^{-01}$	$4,82 \times 10^{-03}$	$-1,36 \times 10^{-04}$	$-2,16 \times 10^{-06}$	$4,31 \times 10^{-08}$	$3,31 \times 10^{-10}$	$-4,96 \times 10^{-12}$			
$ U \leq 40$ m/s											
12 500	9,56	$3,60 \times 10^{-01}$	$9,65 \times 10^{-03}$	$-2,23 \times 10^{-04}$	$-9,49 \times 10^{-06}$	$7,24 \times 10^{-08}$	$3,18 \times 10^{-09}$				
16 000	$1,05 \times 10^{+01}$	$4,52 \times 10^{-01}$	$1,55 \times 10^{-02}$	$-5,11 \times 10^{-04}$	$-2,74 \times 10^{-05}$	$3,99 \times 10^{-07}$	$2,17 \times 10^{-08}$	$-1,12 \times 10^{-10}$	$-5,96 \times 10^{-12}$		
20 000	$1,17 \times 10^{+01}$	$5,61 \times 10^{-01}$	$1,67 \times 10^{-02}$	$-1,03 \times 10^{-03}$	$-2,86 \times 10^{-05}$	$1,43 \times 10^{-06}$	$2,20 \times 10^{-08}$	$-9,34 \times 10^{-10}$	$-5,93 \times 10^{-12}$	$2,24 \times 10^{-13}$	

Where an empty cell occurs in the table, the respective value of a_i shall be taken as zero.

NOTE Compute the value of $C_{3,4}$ from the approximation

$$C_{3,4}(U) = \sum_{i=0}^{10} a_i U^i$$

where U is the mean flow velocity in metres per second. $U < 0$ for the inlet duct and $U > 0$ for the outlet duct.

* In the frequency range covered by this International Standard (i.e. 50 Hz to 10 000 Hz), values for the coefficients a_i are given for the range of flow velocities covered by this International Standard, i.e. $|U| \leq 40$, plus, for information only, for an extended range, $|U| \leq 60$. Also for information only, values are given for an extended frequency range, 12 500 Hz to 20 000 Hz, for flow velocities $|U| \leq 40$.

Annex B (normative)

Determination of the signal-to-noise ratio of sound vs. turbulent pressure fluctuation in the test duct

B.1 General

Two procedures for the determination of the combined mean flow velocity are given in B.2 and B.3. The method described in B.2 is applicable only if the angle of swirl of the flow does not exceed 15°.

B.2 Comparative procedure using a microphone fitted with a nose cone and a microphone fitted with a sampling tube

This procedure requires two measurements:

- a) one using a microphone fitted with a nose cone, and
- b) one using a microphone fitted with a sampling tube.

The method is based on the assumption that the sound signal emitted by a noise source and the turbulent pressure fluctuations excited by the flow at the microphone are mutually uncorrelated and on the experimental observation that there is a difference ΔL_t between the turbulence noise levels sensed by a nose cone microphone and by a microphone fitted with a sampling tube; this difference ΔL_t has to be known as a function of mean flow velocity and frequency (see, for example, Table G.1).

The condition, stated in 7.2.1, specifying that the sound pressure level reading shall be at least 6 dB above the level of turbulent pressure fluctuations (using the sampling tube) is equivalent to another condition: that the difference between the readings of a nose cone microphone and a sampling tube microphone does not exceed a limit ΔL_{\max} which is a function of the turbulence noise suppression ΔL_t of the sampling tube (see Table B.1).

With the fan under test installed and operating, the following steps are necessary to check whether the signal-to-noise ratio of sound versus turbulent pressure fluctuations in the test duct is at least 6 dB.

- Step 1: Measure the mean flow velocity in the duct at the specified radial position of the sampling tube microphone (see Table 7) and determine the turbulence noise suppression value ΔL_t (for example, from the manufacturer's data or, for the sampling tube design shown in Figure G.1, from Table G.1).
- Step 2: Measure the circumferentially averaged sound pressure level in the duct (by using one of the procedures described in 7.2.2 to 7.2.4) with a microphone fitted with a sampling tube placed at its specified radial position (see Table 7), apply the combined frequency response correction $C (= C_1 + C_2 + C_{3,4})$ and record the result as L_{pST} .
- Step 3: Measure the circumferentially averaged sound pressure level in the duct (by using one of the procedures described in 7.2.2 to 7.2.4) with a microphone fitted with nose cone placed midway between the duct axis and the wall ($2r/d = 0,5$), apply the microphone response C_1 (see 3.9) and record the result as L_{pNC} .
- Step 4: Check whether the difference between the circumferentially averaged sound pressure levels obtained with the nose cone and the sampling tube ($L_{pNC} - L_{pST}$) is smaller than or equal to the maximum allowable difference ΔL_{\max} given in Table C.1. If the difference ($L_{pNC} - L_{pST}$) is larger than ΔL_{\max} , then the turbulence noise is less than 6 dB below the sound pressure level reading when using the sampling tube.

Table B.1 — Maximum allowable difference ΔL_{\max} between the sound pressure level readings of a microphone fitted with a nose cone, L_{pNC} , and of a microphone fitted with a sampling tube, L_{pST} , as a function of the turbulence noise suppression ΔL_t of the sampling tube

ΔL_t	$\Delta L_{\max} = \left(\overline{L_{pNC}} - \overline{L_{pST}} \right)_{\max}$
dB	dB
10	5,1
11	5,9
12	6,7
13	7,6
14	8,5
15	9,4
16	10,3
17	11,3
18	12,2
19	13,2
20	14,1
21	15,1
22	16,1
23	17,1
24	18,1
25	19

NOTE For a minimum signal-to-noise ratio of sound to turbulent pressure fluctuations of 6 dB.

B.3 Procedure using a silencer

This procedure requires, for the relevant operating condition of the fan, two determinations of the average sound pressure level L_p , calculated in accordance with 8.1, for each frequency band using a microphone with a sampling tube. For the first determination, the test duct as specified in this International Standard shall be used. For the second determination, that part of the test duct which lies between the fan and the measurement plane is replaced by a silencer which has the same cross-sectional area and the same length as the replaced part of the test duct. The silencer shall have an insertion loss of at least 10 dB for each frequency band of interest (see ISO 7235).

The requirement for the minimum signal-to-noise ratio of the sound vs. turbulence pressure fluctuations of 6 dB (see 7.2.1) is fulfilled if the average sound pressure level determined using the silencer is at least 5 dB below the level determined without using the silencer. This condition shall be met for each frequency band of interest.

B.4 Procedure based on coherence

This procedure is applicable only to the frequency range of plane-wave sound propagation in the test duct. It requires a Fast Fourier Transform analyser. It also requires two identical microphones, both equipped with either sampling tubes, or foam balls, or nose cones. One of these shall be mounted as shown in Figure 10 and the other 180° from it in the same plane and direction. Measurements shall be made with this microphone pair in two positions, 90° apart circumferentially.

For each position of the pair, the coherence function between the two microphone signals shall be obtained, as a function of frequency, from 16 samples of signal. Arithmetic averages of the square roots of the coherence functions shall be computed for all the frequencies in each one-third-octave band. The results shall then be averaged over the two positions of the pair and this composite average shall be squared to yield the power-averaged coherence function, γ^2 , for each one-third-octave band.

If γ^2 is equal to or greater than 0,64, the condition stated in 7.2.1 is met, i.e. the measured sound pressure level is at least 6 dB above the turbulence noise level. Otherwise, the results for the band shall be reported as “not exceeding ... dB”.

NOTE For any frequency band, values of γ^2 greater than 0,64 are proof that the signal-to-noise ratio for turbulence noise is better than 6 dB in that band.

In the frequency range where only plane sound waves can propagate in the test duct, values of γ^2 less than 0,64 indicate that the signal-to-noise ratio of sound to turbulent pressure fluctuations is less than 6 dB.

In the frequency range $f > f_{1,0}$, where higher-order modes can propagate in the test duct, however, values of γ^2 less than 0,64 are not necessarily proof that the signal-to-noise ratio for turbulence noise is less than 6 dB because acoustic cross modes are not fully coherent across the duct. (See reference [23].) If values of γ^2 less than 0,64 are encountered in any frequency band containing the cut-on frequency of the first cross mode, or in any higher frequency band, the procedure given in B.3 may be used to verify the signal-to-noise ratio for turbulence noise.

Annex C (normative)

Computational procedures for calculating the A-weighted sound power level from one-third-octave-band sound power levels

Calculate the A-weighted sound power level, L_{WA} , in decibels (reference sound power 1 pW), from the formula

$$L_{WA} = 10 \lg \sum_{j_{\min}}^{j_{\max}} 10^{0,1[(L_W)_j + C_j]} \text{ dB} \quad (\text{C.1})$$

where

$(L_W)_j$ is the level in the j th one-third-octave band;

$j_{\max} = 27$;

C_j is given in Table C.1.

Table C.1 — Values of C_j according to IEC 60651

j	One-third-octave-band centre nominal frequency Hz	C_j dB
1	50	-30,2
2	63	-26,2
3	80	-22,5
4	100	-19,1
5	125	-16,1
6	160	-13,4
7	200	-10,9
8	250	-8,6
9	315	-6,6
10	400	-4,8
11	500	-3,2
12	630	-1,9
13	800	-0,8
14	1 000	0
15	1 250	0,6
16	1 600	1
17	2 000	1,2
18	2 500	1,3
19	3 150	1,2
20	4 000	1
21	5 000	0,5
22	6 300	-0,1
23	8 000	-1,1
24	10 000	-2,5
25	12 500	-4,3
26	16 000	-6,6
27	20 000	-9,3

Annex D (informative)

Example of calculation of $C_{3,4}$ for a given duct diameter and mean flow velocity

For $d = 0,5$ m, the values of the coefficients a_i for the calculation of $C_{3,4}$ according to Equation (3) are given in Table A.4. For a frequency $f = 1\ 000$ Hz

$$C_{3,4} = (1,85 + 0,038U)\text{dB} \quad (\text{D.1})$$

For a mean flow velocity $U = 15$ m/s (outlet duct)

$$C_{3,4} = (1,85 + 0,038 \times 15)\text{dB} \approx 2,4 \text{ dB} \quad (\text{D.2})$$

Likewise, for $U = -15$ m/s (inlet duct)

$$C_{3,4} = [1,85 + 0,038 \times (-15)]\text{dB} \approx 1,3 \text{ dB} \quad (\text{D.3})$$

See also data listed in Table D.1. Figure D.1 illustrates the behaviour of the value of $C_{3,4}$ as a function of the mean flow velocity U .

Table D.1 — Value of correction $C_{3,4}$ in decibels for $d = 0,5$ m and different flow velocities U

f Hz	U m/s					
	5	-5	15	-15	30	-30
50	0,1	-0,2	0,4	-0,5	0,8	-0,9
63	0,1	-0,2	0,4	-0,5	0,8	-0,9
80	0,1	-0,2	0,4	-0,5	0,8	-0,9
100	0,1	-0,2	0,4	-0,5	0,8	-0,9
125	0,1	-0,2	0,4	-0,5	0,8	-0,9
160	0,1	-0,2	0,4	-0,5	0,8	-0,9
200	0,1	-0,2	0,4	-0,5	0,8	-0,9
250	0,1	-0,2	0,4	-0,5	0,8	-0,9
315	-0,5	-0,8	-0,2	-1,1	0,2	-1,5
400	-0,3	-0,6	0	-0,9	0,5	-1,3
500	-0,2	-0,5	0,2	-0,8	0,6	-1,2
630	0,2	-0,1	0,6	-0,4	1,1	-0,9
800	1,2	0,9	1,6	0,5	2,1	0
1 000	2	1,7	2,4	1,3	3	0,7
1 250	2,8	2,4	3,3	2	4	1,4
1 600	3,4	2,9	4	2,4	4,9	1,7

Table D.1 (continued)

f Hz	U m/s					
	5	-5	15	-15	30	-30
2 000	4	3,3	4,7	2,7	5,8	1,8
2 500	4,5	3,7	5,4	2,9	6,9	1,9
3 150	5,2	4,1	6,5	3,1	8,4	2,1
4 000	6,2	4,9	7,7	3,8	10,2	2,8
5 000	6,8	5,3	8,7	4,2	11,8	3,2
6 300	7,9	6,1	10,1	4,7	13,7	3,8
8 000	9,3	7	12,2	5,6	16,2	4,9
10 000	10,5	7,6	13,9	5,9	17,9	5,6
12 500	11,6	8	16	6,7	19,5	6,4
16 000	13,1	8,7	18,2	7,5	21,2	7,3
20 000	14,8	9,4	20,2	8,4	23,6	7,9

NOTE 1 $U > 0$ for the outlet duct, $U < 0$ for the inlet duct.
 NOTE 2 Results of example calculation are marked by a bold frame line.

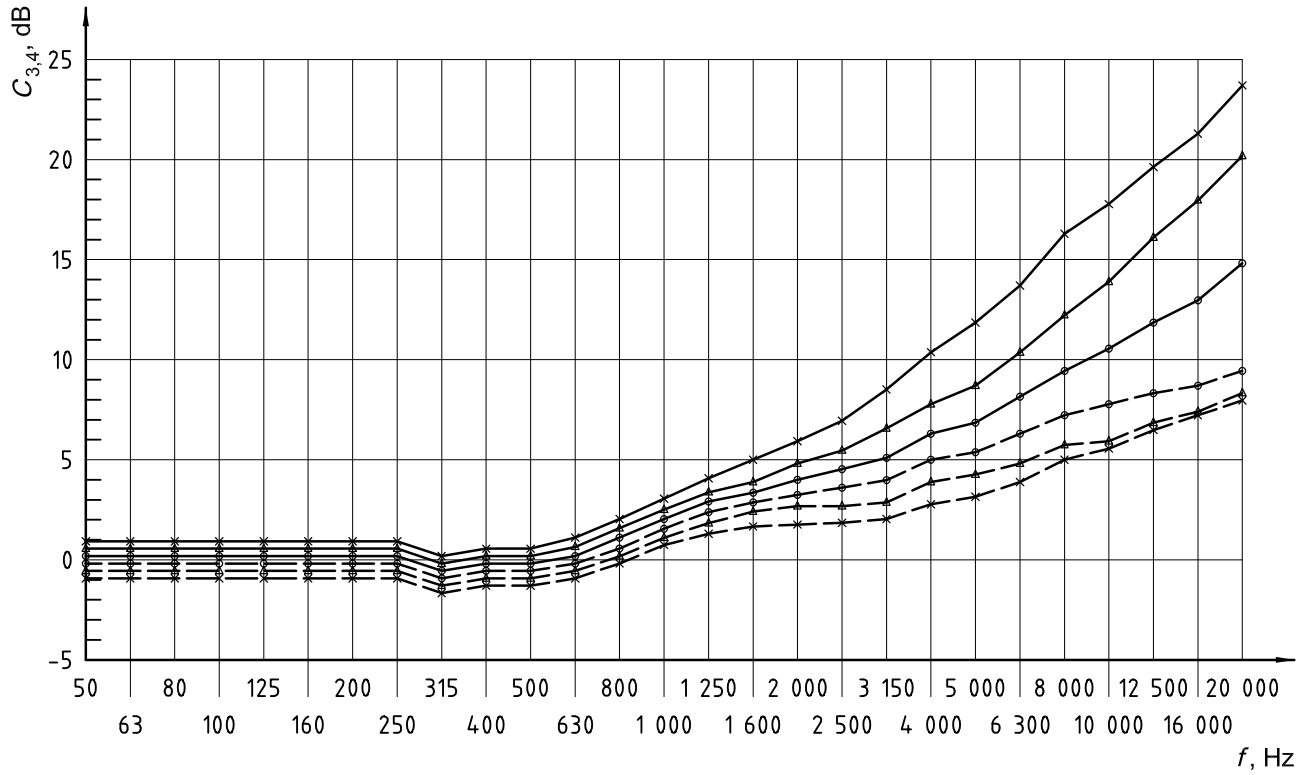

- Key**
- $U = 5 \text{ m/s}$
 - -○- - $U = -5 \text{ m/s}$
 - △— $U = 15 \text{ m/s}$
 - -△- - $U = -15 \text{ m/s}$
 - ×— $U = 30 \text{ m/s}$
 - -×- - $U = -30 \text{ m/s}$

Figure D.1 — Value of $C_{3,4}$ as a function of mean flow velocity U for $d = 0,5 \text{ m}$

Annex E (informative)

Guidelines for the design and construction of an anechoic termination

E.1 The primary feature of an anechoic termination is a sufficiently gradual change in duct area to suppress the reflection of the sound waves back into the duct where they would interfere with the sound level measurements. The criterion for this is specified in 5.2.7 in terms of a maximum permissible pressure reflection coefficient. A procedure for determining whether a given termination meets the requirements of 5.2.7 is described in Annex F.

E.2 A number of different designs meeting the requirements of 5.2.7 have been described in, for example, references [2], [4], [6], [9], [12], [13], [14], [17] and [18].

E.3 Designs which have been successfully used in several laboratories are shown in detail in Figures E.1 to E.5. In these designs the gradual change in the cross-sectional area of the duct approximates an exponential or a catenoidal horn. The latter gives a slightly better performance than an exponential horn. As in most successful anechoic terminations, part of the horn is filled with absorptive material to provide attenuation for the noise of devices used for controlling and measuring the air flow which are usually attached to the end of the horn. Details of the performance of these horns and the effect of various design alternatives are given in references [6], [9] and [12].

It is not necessary to adhere exactly to the exponential or catenoidal profile. Approximation to these profiles by conical sections, as shown in Figures E.1 a), E.2, E.3 and E.5, is adequate.

In the other type there is a stepped increase in cross-sectional area from the duct to the terminator body. Schematics of such stepped terminations are shown in Figures E.6 and E.7.

E.4 Since the inlet of the anechoic termination and the outlet of the duct form a smooth transition, the internal diameters are equal at the connection, as shown in Figure E.1 a), anechoic termination. All anechoic termination dimensions are given in terms of the internal diameter d_1 of the outlet of the duct. Scaling to diameters other than those tested should only be done to a limited degree, however, because the ratio of wavelength to dimensions will be changed. The outer skin of the termination may be made of any material having sufficient strength to retain its dimensional characteristics.

In the anechoic termination shown in Figure E.1 a), the aerodynamic passage through the centre of the horn is outlined by perforated metal having about 58 % open area. Particular attention should be paid to the smoothness of the transition at d_1 . The volume between the perforated metal and the conical sections of the horn is filled with open-celled foam or fibre glass of density approximately 24 kg/m^3 . The remaining cylindrical volume at d_4 is filled with fibre glass of density approximately 48 kg/m^3 .

E.5 If transitions are to be used between the test duct and the anechoic termination, the transition is considered part of the anechoic termination, i.e. the anechoic termination together with the transition has to meet the requirements of 5.2.7.

E.6 Examples of throttling devices are given in Figure E.8.

In Figure E.8 a throttling device is described which consists of nine exchangeable screens which provide gradually increasing flow resistance. Design of screens is detailed in Table E.1.

E.7 Details of anechoic terminations with stepped expansion sections are shown in Figures E.6 and E.7. Reflections of sound occur at each change in cross-section and the overall anechoic effect is obtained by having the lengths of sections adjusted so that reflected waves cancel out. Steps increasing in diameter by about 10 % and step lengths of about 0,3 m to 0,4 m are likely to be found suitable.

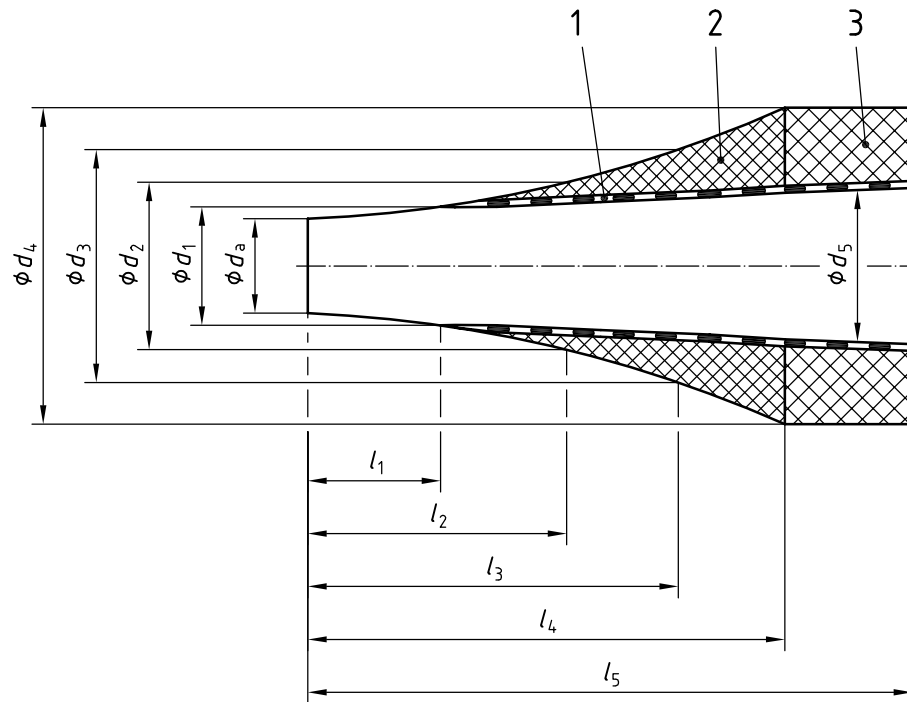

Duct internal diameter, d_a			
d_1	$1,15 d_a$	l_1	$1,44 d_a$
d_2	$1,64 d_a$	l_2	$2,89 d_a$
d_3	$2,25 d_a$	l_3	$3,89 d_a$
d_4	$3,44 d_a$	l_4	$5,11 d_a$
d_5	$1,67 d_a$	l_5	$6,44 d_a$

Key

- 1 perforated metal, approximately 58 % open
- 2 open-celled foam or fibreglass having a density of 24 kg/m^3
- 3 fibre glass having a density of 48 kg/m^3

a) Anechoic termination tested for diameter $d_a = 0,46 \text{ m}$ (see reference [9])

Figure E.1 — Examples of anechoic terminations

Dimensions in millimetres

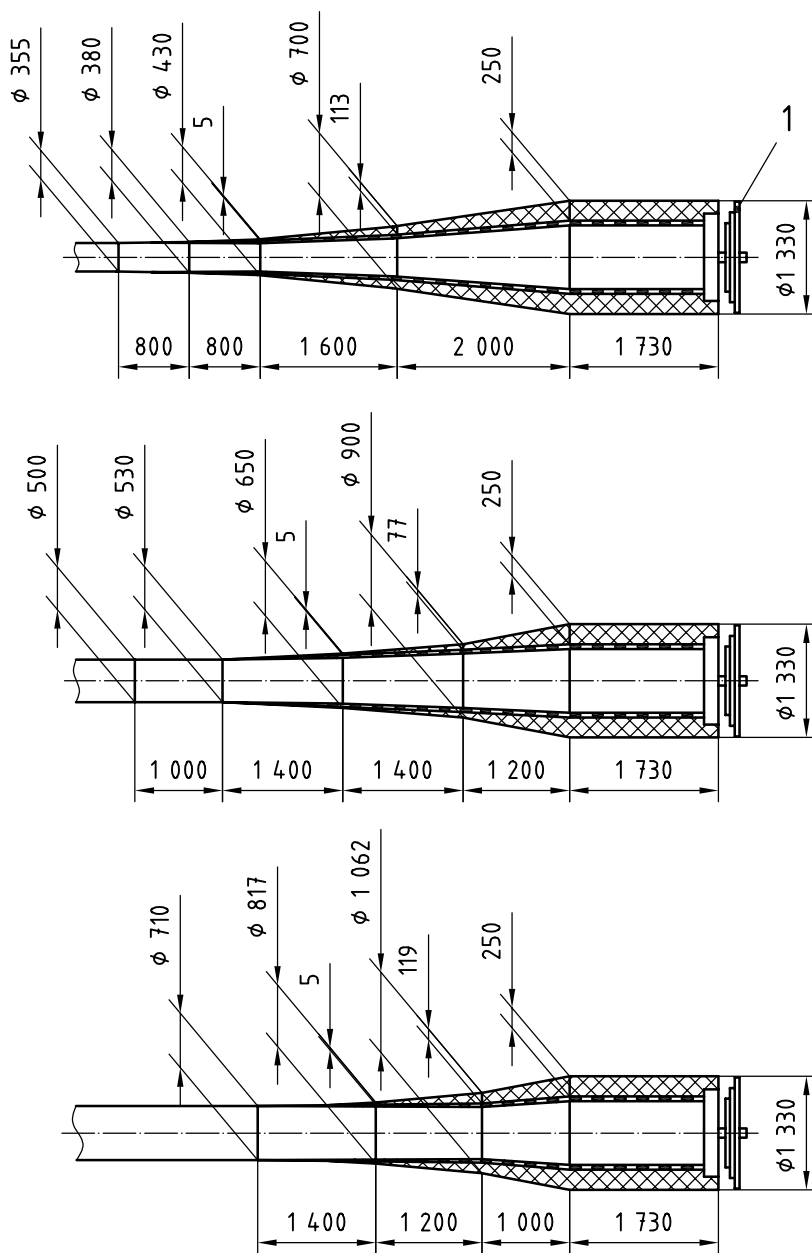

NOTE The lining is of expanded polyurethane foam of density 32 kg/m³.

b) Three catenoidal designs of anechoic termination

Figure E.1 — Examples of anechoic terminations (continued)

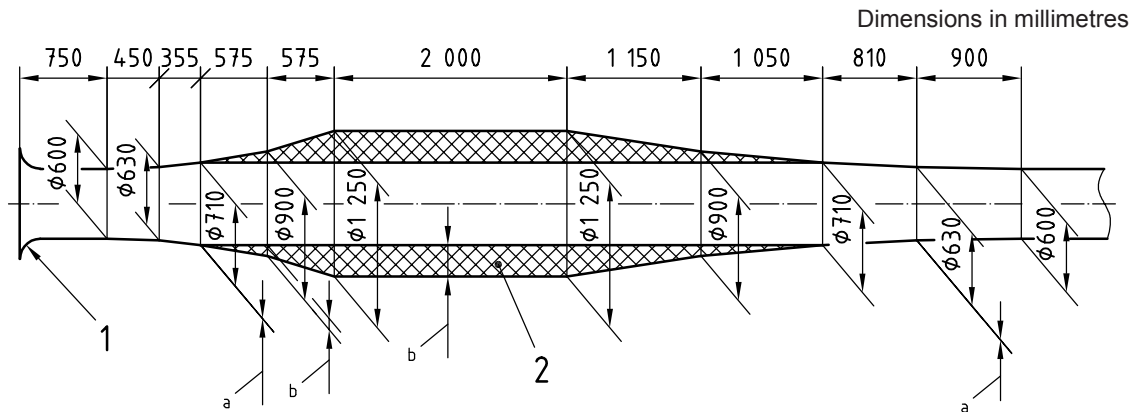

Key

- 1 flow measurement device
- 2 expanded polyurethane foam having a density of 32 kg/m³
- a No lining
- b Thick lining

Figure E.2 — Example of inlet anechoic termination (catenoidal)

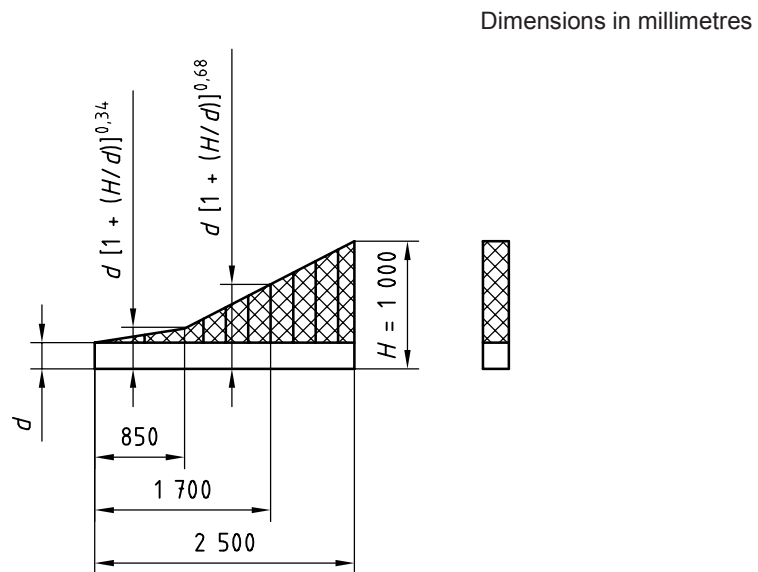

NOTE Tested for $d \leq 250$ mm (see reference [10]); for $d > 250$ mm, the length of the termination is to be increased, or two-sided anechoic terminations may be used, see Figure E.5 (see reference [14]).

Figure E.3 — Example of one-sided anechoic termination

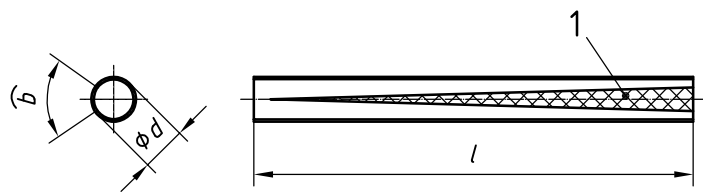

Key

1 triangular slot

$l = 9d$, $b = 0,6d$, covered with porous material

NOTE 1 Flow resistance equals approximately $400 \text{ N}\cdot\text{s}/\text{m}^3$ ($\approx \rho c$).

NOTE 2 Tested for $d \leq 0,3 \text{ m}$ (see reference [6]).

Figure E.4 — Example of anechoic termination

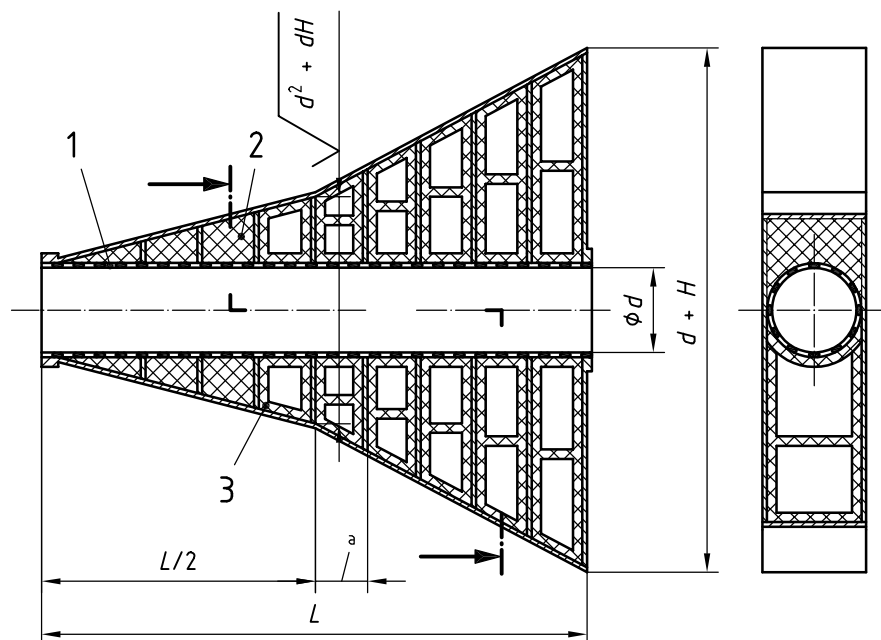

Key

1 perforated sheet, 33 % open area

2 mineral wool, $\rho \approx 43 \text{ kg}/\text{m}^3$

3 mineral wool, 20 mm thick, $\rho \approx 50 \text{ kg}/\text{m}^3$, $\Xi W 5 \text{ kN}\cdot\text{s}/\text{m}^4$, where Ξ is the flow resistance per unit length (thickness of damping material)

$L \geq 5d$

$H = 200 \text{ mm}$

^a 250 mm to 300 mm

NOTE Tested for $d = 400 \text{ mm}$, $d = 500 \text{ mm}$ (see reference [18]), and for $d = 630 \text{ mm}$.

Figure E.5 — Example of two-sided anechoic termination

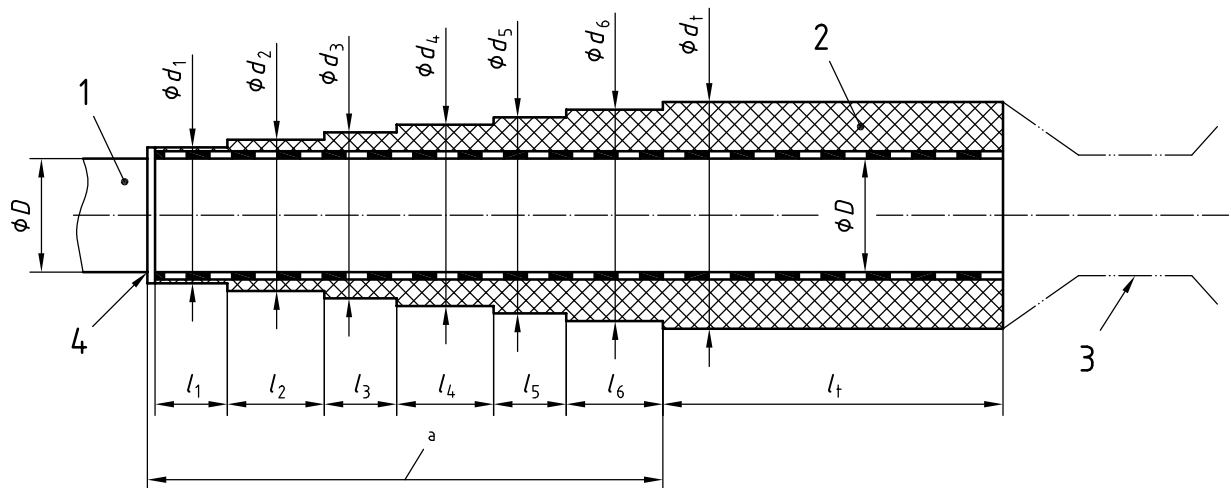

Dimensions in millimetres

Test duct diameter ϕD	No. step expansion	d_1	l_1	d_2	l_2	d_3	l_3	d_4	l_4	d_5	l_5	d_6	l_6	Terminator diameter d_t	Terminator length l_t
400	6	450	240	500	320	550	240	600	320	650	240	700	320	750	1 125
630	4	700	240	780	320	850	240	925	—	—	—	—	—	1 000	1 500
1 000	3	1 150	240	1 300	320	1 450	240	—	—	—	—	—	—	1 600	2 400

Key

- 1 test duct
- 2 mineral wool having a density of 45 kg/m³
- 3 measuring nozzle
- 4 flanged entry point

Figure E.6 — Example of a stepped anechoic termination

Dimensions in millimetres

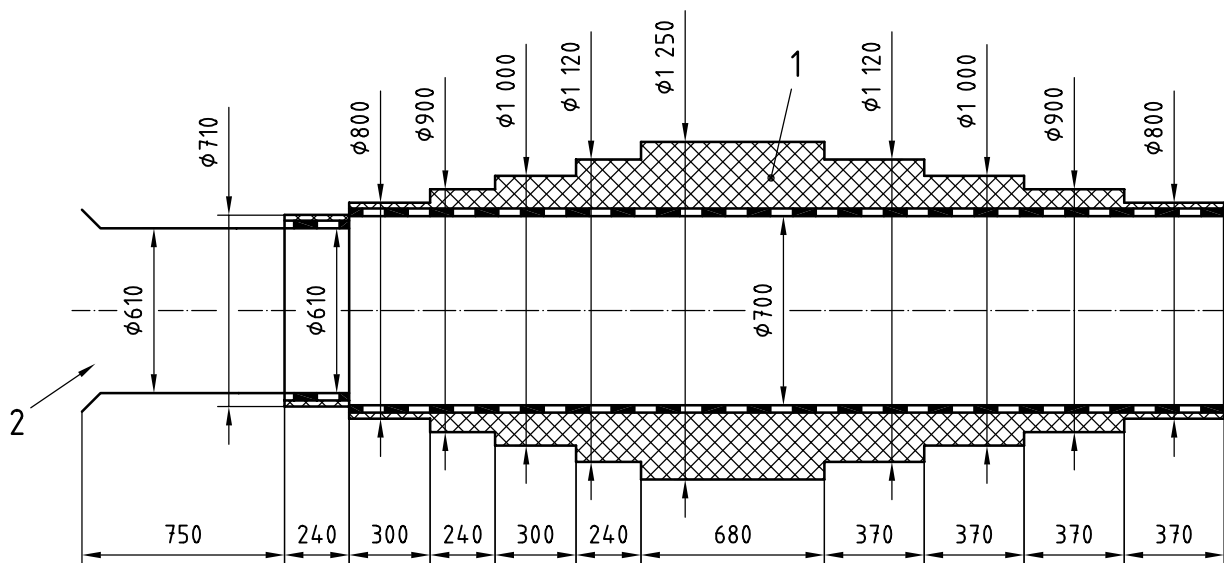

Key

- 1 expanded polyurethane foam of density of 32 kg/m³
- 2 flow measurement device

Figure E.7 — Example of a stepped inlet anechoic termination (catenoidal)

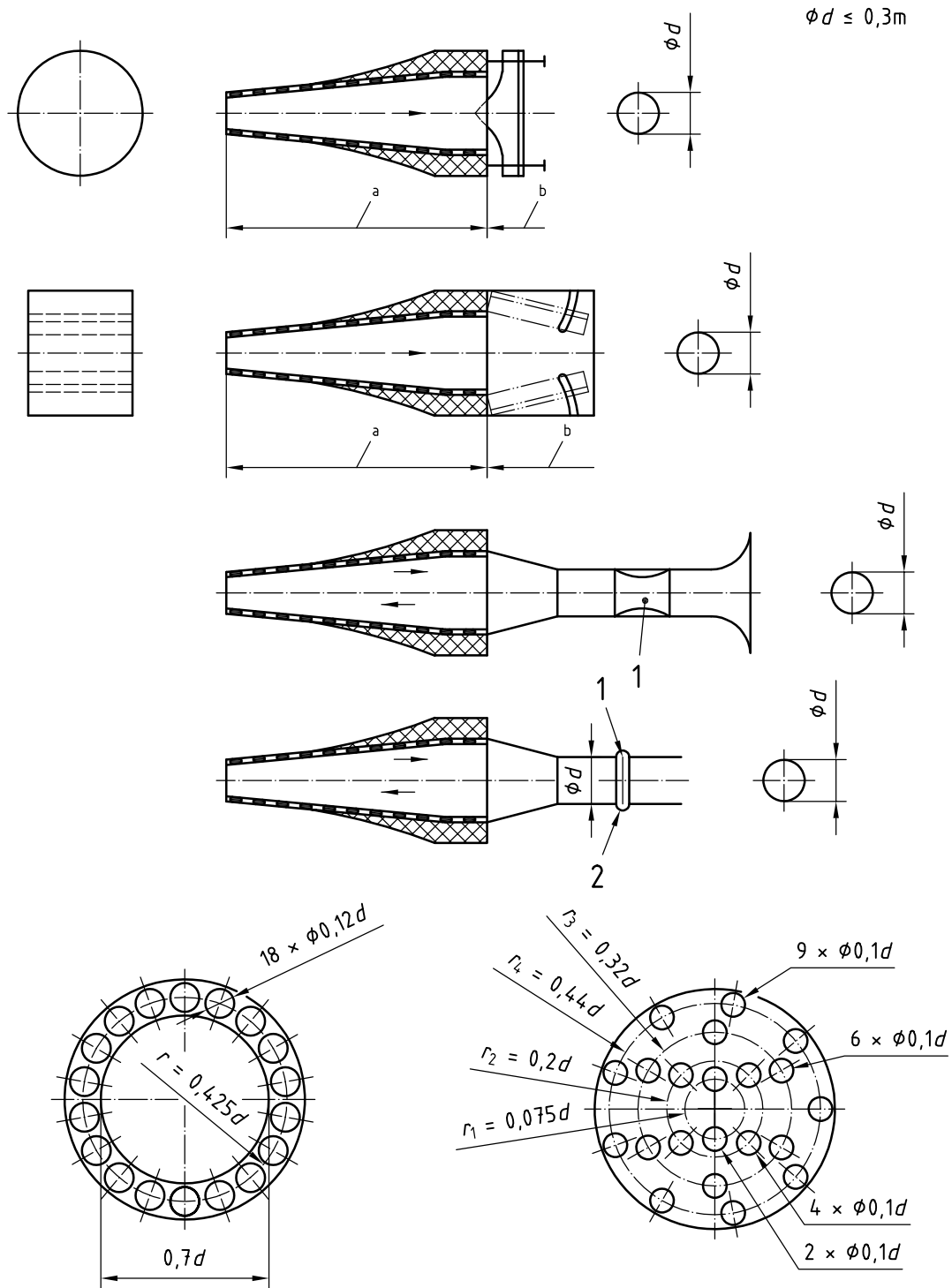

Key

- 1 throttle
- 2 exchangeable screen
- a Anechoic termination
- b Throttling device

Figure E.8 — Examples of throttling sections

Table E.1 — Design of screens

Orifice position in radius	Screen number								
	2	3	4	5	6	7	8	9	10
Number of boreholes at radius r_i									
r	18	9	—	—	—	—	—	—	—
r_1	—	—	3	3	3	2	2	2	—
r_2	—	—	10	10	5	4	5	4	—
r_3	—	—	16	12	8	6	7	4	—
r_4	—	—	24	16	12	9	—	—	—

Annex F (informative)

Evaluation of performance of anechoic terminations

F.1 This annex gives an example of the determination of the sound pressure reflection coefficient. Calculate the pressure reflection coefficient, r_a , from a measurement of the difference ΔL between the maximum and minimum sound pressure levels occurring in the duct as a result of the standing wave formed by the incident and the reflected plane waves at each centre frequency of the frequency bands, using the formula

$$r_a = \frac{10^{\Delta L/20} - 1}{10^{\Delta L/20} + 1} \quad (\text{F.1})$$

F.2 It is recommended that the pressure reflection coefficient be measured in the frequency range of plane-wave sound propagation in the test duct.

F.3 A procedure for evaluating the anechoic termination performance is given below.

- a) After connecting the test duct to the anechoic termination, mount a high-quality loudspeaker in a baffle which covers the inlet of the test duct.
- b) Make provision for moving a microphone without the sampling tube along the full length of the centre line of the measurement duct.
- c) Apply a pure-tone signal from an audio oscillator to the loudspeaker, via an amplifier if necessary, for the centre frequency of the one-third-octave band.
- d) Filter the microphone signal through a narrow-band or a one-third-octave-band analyser and then apply the filtered output signal to a graphic level recorder.
- e) Move the microphone along the axis of the measurement duct to measure the difference between the maximum and minimum sound pressure levels.
- f) Calculate the difference between the maximum and minimum sound pressure levels (ΔL) and insert it into Equation (F.1). Compare the reflection coefficient r_a obtained with the values listed in Table 5.
- g) Repeat steps c), d) and e) for the centre frequencies of the one-third-octave bands between 50 Hz and f_0 .
- h) If the anechoic termination is fitted with a means of flow rate control (throttle), repeat step g) with the throttle set to give maximum flow rate and then to give minimum flow rate.

If the graphic level recorder mentioned in d) is not available, manual recording of the maximum and minimum sound pressure levels is permitted.

F.4 Other techniques such as the two-microphone technique may also be used. This method detailed in reference [20] consists in measuring the transfer function between the signals of two close microphones (see experimental arrangement in Figure F.1). This method only applies with no flow and at low frequencies, i.e. within the plane-wave sound propagation frequency range.

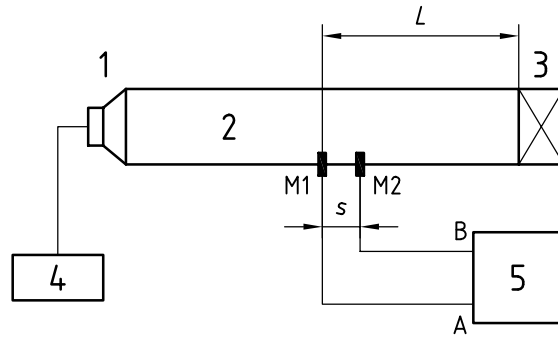

Key

- 1 loudspeaker
- 2 duct
- 3 reflecting element
- 4 random-signal generator
- 5 dual-channel analyser
- M1 and M2 are microphones.

Figure F.1 — Experimental arrangement and instrumentation for the two-microphone technique

The procedure for evaluating the anechoic termination performance by this method is as follows.

- a) After connecting the test duct to the anechoic termination (called reflecting element in Figure 1), mount a high-quality loudspeaker at the duct inlet.
- b) Mount two microphones M1 and M2 flush-mounted on the duct wall, axially spaced 30 mm to 50 mm apart. The distance between the test section and the loudspeaker or the reflecting element should be $2D$ at least, where D is the duct diameter.
- c) Apply a random signal to the loudspeaker within the frequency range of interest, i.e. within the range of plane-wave sound propagation.
- d) Measure with a dual-channel Fourier analyser the complex transfer function H_{12} of the signals of the two microphones M1 and M2, where M1 is the closest to the loudspeaker.
- e) Calculate the complex pressure reflection coefficient R from the formula:

$$R = \frac{H_{12} - e^{-iks}}{e^{iks} - H_{12}} e^{2ikL} \tag{F.2}$$

where

- k is the wave number;
- s is the microphone spacing;
- L is the axial distance between microphone M1 and the inlet plane of the anechoic termination (reflecting element in Figure F.1).

The reflection coefficient r_a is the magnitude of the complex coefficient R

$$r_a = \sqrt{\text{Re}(R)^2 + \text{Im}(R)^2}$$

The values of the reflection coefficient r_a with respect to frequency may be averaged over each one-third octave frequency band to evaluate the performance of anechoic terminations in light of Table 5 in 5.2.7.

The use of the microphone switching procedure as described in reference [20] is recommended to eliminate electrical phase shift problems between the two microphone channels, which dramatically increase the uncertainty in the reflection coefficient determination at low frequency.

Annex G (informative)

Sampling tube information

G.1 A general description and schematic of a typical sampling tube are given in 3.9.1 and Figure 1.

G.2 Specific design details that may be used for fabricating a sampling tube are given in Figures G.1 and G.2.

Other designs are described in references [11], [16], [29] and [40].

Figure G.3 illustrates the mountings of a microphone and sampling tube.

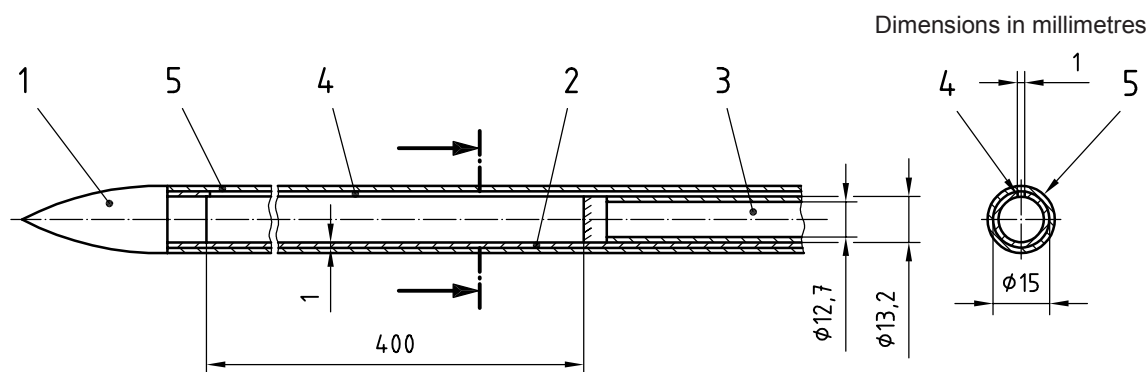

Key

- 1 nose cone having the same diameter as the outside diameter of the slit covering material
- 2 slit-tube
- 3 microphone with protection grid (the inner diameter of the slit tube is to be machined to give a sliding fit for the microphone protection grid of nominal diameter 13,2 mm)
- 4 slit covered with porous material
- 5 porous material with an acoustic flow resistance of $2\rho c$, i.e. approximately 800 Pa·s/m

Figure G.1 — Details of a basic sampling tube for a 13 mm (1/2-inch) microphone

Dimensions in millimetres

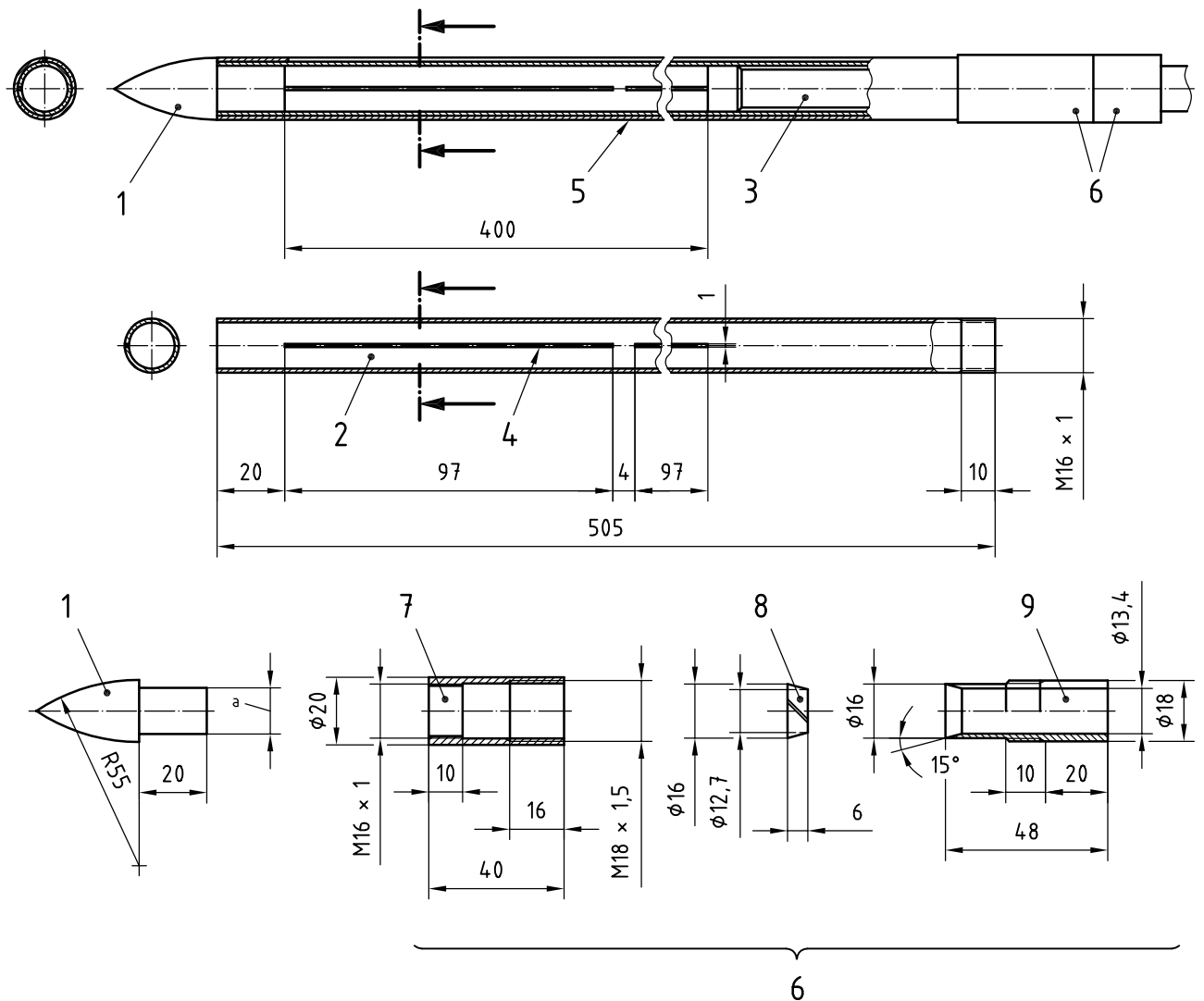

Key

- 1 nose cone having the same diameter as the outside diameter of the slit covering material
- 2 slit-tube
- 3 microphone with protection grid (the inner diameter of the slit tube is to be machined to give a sliding fit for the microphone protection grid of nominal diameter 13,2 mm)
- 4 slit covered with porous material
- 5 porous material with an acoustic flow resistance of $2\rho c \approx 800 \text{ Pa}\cdot\text{s/m}$
- 6 compression fitting
- 7 collet nut, brass
- 8 split collet ring, plastic
- 9 insert, brass

^a Diameter should match inside diameter of slit for a snug fit.

Figure G.2 — Sampling tube with optional features serving to improve the stability and performance of the sampling tube

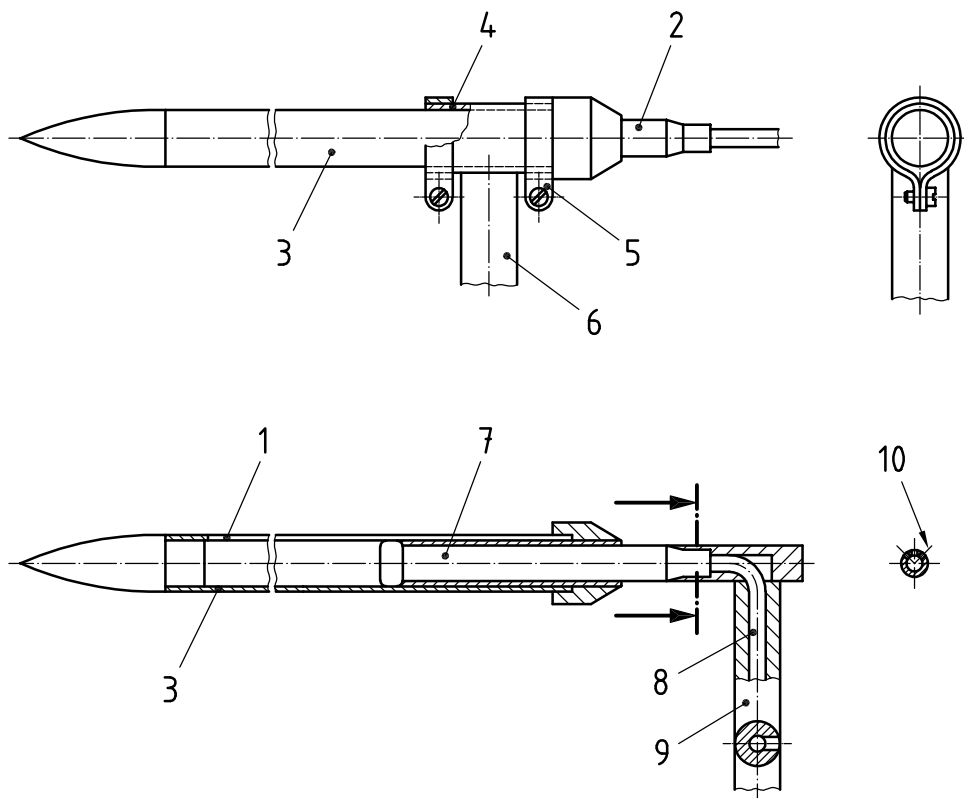

Key

- 1 slit
- 2 microphone
- 3 sampling tube
- 4 clamp collar
- 5 hose clamp
- 6 supporting beam
- 7 microphone with protection grid
- 8 microphone cable
- 9 supporting tube
- 10 fixing screws

NOTE For inlet side measurements, see 6.1.

Figure G.3 — Typical mountings of microphone and sampling tube

G.3 Turbulence noise suppression

Table G.1 lists the magnitudes of the suppression of turbulent pressure fluctuations of such a typical sampling tube as compared to a 13 mm nose cone.

Table G.1 — Turbulence noise suppression, ΔL_t , of the typical sampling tube shown in Figure 1 as compared to a 13 mm nose cone

One-third-octave-band centre frequency Hz	Turbulence noise suppression for mean flow velocity, ΔL_t			
	dB			
	10 m/s	20 m/s	30 m/s	40 m/s
50	18	14	12	11
63	19	15	14	13
80	19	17	16	14
100	20	20	18	16
125	20	19	17	16
160	20	19	17	16
200	22	19	18	17
250	22	20	19	18
315	21	22	20	18
400	>20	22	20	18
500	>20	22	20	19
630	>20	23	21	22
800	>20	>20	>20	>20
1 000	>20	>20	>20	>20
1 250	>20	>20	>20	>20
1 600	>20	>20	>20	>20
2 000	>20	>20	>20	>20
2 500	>20	>20	>20	>20
3 150	>20	>20	>20	>20
4 000	>20	>20	>20	>20
5 000	>20	>20	>20	>20
6 300	>20	>20	>20	>20
8 000	>20	>20	>20	>20
10 000	>20	>20	>20	>20

Annex H (informative)

Test method for small ducted fans

The range of test duct diameters specified in this International Standard is from 0,15 m to 2,0 m. According to 5.2.3, the minimum fan inlet or outlet diameter is then 0,104 m. If devices with even smaller inlet or outlet diameters are to be measured, it is recommended here to use test duct diameters down to 0,07 m diameter. This allows testing of test fans down to 0,048 m diameter.

The radial position of the microphone with the sampling tube in the test duct is $2r/d = 0,8$.

It is no longer possible to use sampling tubes with 15 mm diameter as suggested in Annex G [5.3.3.2 b) allows the use of sampling tubes with 22 mm diameter]. Therefore smaller sampling tubes and smaller microphones must be used. Figure H.1 shows the design of a sampling tube suitable for commercially available microphones of 6,4 mm diameter.

NOTE Since the small sampling tubes are not yet commercially available, the test method for small duct diameters cannot be a normative part of this International Standard.

Values for the coefficients a_i necessary to compute the mean flow velocity-modal corrections $C_{3,4}$ according to Equation (3) are given in Tables H.1 to H.3 for the following diameter ranges of the test duct:

- 0,07 m \cup $d < 0,09$ m
- 0,09 m \cup $d < 0,12$ m
- 0,12 m \cup $d < 0,15$ m

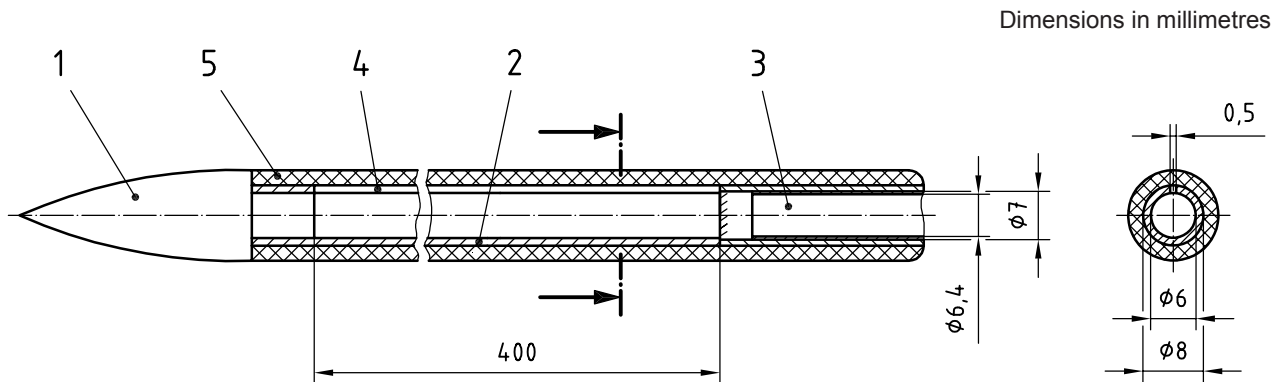

Key

- 1 nose cone having the same diameter as the outside diameter of the slit covering material
- 2 slit-tube
- 3 microphone with protection grid (the inner diameter of the slit tube is to be machined to give a sliding fit for the microphone protection grid of nominal diameter 7 mm)
- 4 slit covered with porous material
- 5 porous material with an acoustic flow resistance of $2\rho c \approx 800$ Pa·s/m

Figure H.1 — Schematic of a sampling tube for a 6,4 mm (1/4 inch) microphone

Table H.1 — Values of coefficients a_i for the determination of the combined mean flow velocity and modal correction $C_{3,4}$ of the sampling tube for duct diameters 0,07 m \cup $d < 0,09$ m

$a_i, \text{dB}\cdot\text{s}^i\cdot\text{m}^{-i}$											
f, Hz	a_0	a_1	a_2	a_3	a_4	a_5	a_6	a_7	a_8	a_9	a_{10}
$ U \cup 60 \text{ m/s}^*$											
$\cup 630$	$-5,00 \times 10^{-02}$	$2,70 \times 10^{-02}$									
800	$-1,19 \times 10^{-03}$	$2,97 \times 10^{-02}$	$5,75 \times 10^{-05}$								
1 000	$-2,12 \times 10^{-02}$	$2,85 \times 10^{-02}$	$1,18 \times 10^{-04}$								
1 250	$-1,53 \times 10^{-02}$	$2,77 \times 10^{-02}$	$2,15 \times 10^{-04}$								
1 600	$-7,37 \times 10^{-03}$	$3,10 \times 10^{-02}$	$3,78 \times 10^{-04}$	$-2,50 \times 10^{-06}$							
2 000	$-3,40 \times 10^{-02}$	$3,13 \times 10^{-02}$	$6,24 \times 10^{-04}$	$-4,10 \times 10^{-06}$							
2 500	$5,47 \times 10^{-01}$	$3,16 \times 10^{-02}$	$1,01 \times 10^{-03}$	$-6,19 \times 10^{-06}$							
3 150	1,93	$2,29 \times 10^{-02}$	$1,44 \times 10^{-03}$	$1,67 \times 10^{-06}$	$-1,11 \times 10^{-07}$						
4 000	2,38	$3,81 \times 10^{-02}$	$1,26 \times 10^{-03}$	$1,25 \times 10^{-05}$	$-1,43 \times 10^{-07}$						
5 000	3,17	$9,44 \times 10^{-02}$	$1,20 \times 10^{-03}$	$-1,94 \times 10^{-06}$	$6,47 \times 10^{-08}$						
6 300	3,81	$1,37 \times 10^{-01}$	$3,38 \times 10^{-03}$	$-2,81 \times 10^{-05}$	$-4,82 \times 10^{-07}$	$5,51 \times 10^{-09}$					
8 000	4,81	$1,65 \times 10^{-01}$	$6,53 \times 10^{-03}$	$-1,87 \times 10^{-05}$	$-2,75 \times 10^{-06}$	$7,40 \times 10^{-10}$	$3,96 \times 10^{-10}$				
10 000	5,50	$2,14 \times 10^{-01}$	$1,09 \times 10^{-02}$	$-3,22 \times 10^{-05}$	$-8,08 \times 10^{-06}$	$-5,68 \times 10^{-09}$	$2,57 \times 10^{-09}$	$2,11 \times 10^{-12}$	$-2,79 \times 10^{-13}$		
$ U \cup 40 \text{ m/s}$											
12 500	6,56	$2,78 \times 10^{-01}$	$1,44 \times 10^{-02}$	$-9,06 \times 10^{-05}$	$-1,34 \times 10^{-05}$	$1,00 \times 10^{-08}$	$4,35 \times 10^{-09}$				
16 000	7,57	$3,81 \times 10^{-01}$	$2,43 \times 10^{-02}$	$-3,30 \times 10^{-04}$	$-4,21 \times 10^{-05}$	$1,81 \times 10^{-07}$	$3,30 \times 10^{-08}$	$-3,24 \times 10^{-11}$	$-8,91 \times 10^{-12}$		
20 000	8,79	$4,89 \times 10^{-01}$	$3,57 \times 10^{-02}$	$-7,98 \times 10^{-04}$	$-9,13 \times 10^{-05}$	$9,65 \times 10^{-07}$	$1,20 \times 10^{-07}$	$-5,69 \times 10^{-10}$	$-7,30 \times 10^{-11}$	$1,26 \times 10^{-13}$	$1,65 \times 10^{-14}$
Where an empty cell occurs in the table, the respective value of a_i shall be taken as zero.											
NOTE Compute the value of $C_{3,4}$ from the approximation											
$C_{3,4}(U) = \sum_{i=0}^{10} a_i U^i$											
where U is the mean flow velocity in metres per second. $U < 0$ for the inlet duct and $U > 0$ for the outlet duct.											
* In the frequency range covered by this International Standard (i.e. 50 Hz to 10 000 Hz), values for the coefficients a_i are given for the range of flow velocities covered by this International Standard, i.e. $ U \cup 40$, plus, for information only, for an extended range, $ U \cup 60$. Also for information only, values are given for an extended frequency range, 12 500 Hz to 20 000 Hz, for flow velocities $ U \cup 40$.											

Table H.2 — Values of coefficients a_i for the determination of the combined mean flow velocity and modal correction $C_{3,4}$ of the sampling tube for duct diameters 0,09 m u $d < 0,12$ m

$a_i, \text{dB}\cdot\text{s}^i\cdot\text{m}^{-i}$											
f, Hz	a_0	a_1	a_2	a_3	a_4	a_5	a_6	a_7	a_8	a_9	a_{10}
$ U \cup 60 \text{ m/s}^*$											
u 630	$-5,00 \times 10^{-02}$	$2,70 \times 10^{-02}$									
800		$2,97 \times 10^{-02}$	$5,75 \times 10^{-05}$								
1 000		$2,85 \times 10^{-02}$	$1,18 \times 10^{-04}$								
1 250		$2,77 \times 10^{-02}$	$2,10 \times 10^{-04}$								
1 600		$3,10 \times 10^{-02}$	$3,73 \times 10^{-04}$	$-2,50 \times 10^{-06}$							
2 000	$7,80 \times 10^{-01}$	$3,08 \times 10^{-02}$	$6,07 \times 10^{-04}$	$-3,23 \times 10^{-06}$							
2 500	1,86	$3,32 \times 10^{-02}$	$4,02 \times 10^{-04}$	$2,62 \times 10^{-06}$							
3 150	2,04	$6,56 \times 10^{-02}$	$5,09 \times 10^{-04}$								
4 000	2,66	$9,61 \times 10^{-02}$	$1,10 \times 10^{-03}$	$-8,15 \times 10^{-06}$							
5 000	3,25	$1,07 \times 10^{-01}$	$2,64 \times 10^{-03}$	$-3,04 \times 10^{-06}$	$-3,62 \times 10^{-07}$						
6 300	4,11	$1,38 \times 10^{-01}$	$3,47 \times 10^{-03}$	$-8,01 \times 10^{-06}$	$-5,62 \times 10^{-07}$						
8 000	5,32	$1,83 \times 10^{-01}$	$5,87 \times 10^{-03}$	$-2,37 \times 10^{-05}$	$-2,26 \times 10^{-06}$	$5,49 \times 10^{-10}$	$3,06 \times 10^{-10}$				
10 000	6,23	$2,46 \times 10^{-01}$	$7,71 \times 10^{-03}$	$-7,61 \times 10^{-05}$	$-3,43 \times 10^{-06}$	$1,12 \times 10^{-08}$	$5,25 \times 10^{-10}$				
$ U \cup 40 \text{ m/s}$											
12 500	7,04	$3,11 \times 10^{-01}$	$1,45 \times 10^{-02}$	$-1,70 \times 10^{-04}$	$-1,30 \times 10^{-05}$	$4,55 \times 10^{-08}$	$4,14 \times 10^{-09}$				
16 000	8,10	$3,98 \times 10^{-01}$	$2,43 \times 10^{-02}$	$-4,36 \times 10^{-04}$	$-4,00 \times 10^{-05}$	$3,04 \times 10^{-07}$	$3,04 \times 10^{-08}$	$-7,62 \times 10^{-11}$	$-8,13 \times 10^{-12}$		
20 000	9,58	$5,01 \times 10^{-01}$	$2,86 \times 10^{-02}$	$-9,90 \times 10^{-04}$	$-4,72 \times 10^{-05}$	$1,35 \times 10^{-06}$	$3,55 \times 10^{-08}$	$-8,59 \times 10^{-10}$	$-9,48 \times 10^{-12}$	$2,01 \times 10^{-13}$	
Where an empty cell occurs in the table, the respective value of a_i shall be taken as zero.											
NOTE Compute the value of $C_{3,4}$ from the approximation											
$C_{3,4}(U) = \sum_{i=0}^{10} a_i U^i$											
where U is the mean flow velocity in metres per second. $U < 0$ for the inlet duct and $U > 0$ for the outlet duct.											
* In the frequency range covered by this International Standard (i.e. 50 Hz to 10 000 Hz), values for the coefficients a_i are given for the range of flow velocities covered by this International Standard, i.e. $ U \cup 40$, plus, for information only, for an extended range, $ U \cup 60$. Also for information only, values are given for an extended frequency range, 12 500 Hz to 20 000 Hz, for flow velocities $ U \cup 40$.											

Table H.3 — Values of coefficients a_i for the determination of the combined mean flow velocity and modal correction $C_{3,4}$ of the sampling tube for duct diameters 0,12 m \cup $d < 0,15$ m

$a_i, \text{dB}\cdot\text{s}^i\cdot\text{m}^{-i}$											
f, Hz	a_0	a_1	a_2	a_3	a_4	a_5	a_6	a_7	a_8	a_9	a_{10}
$ U \cup 60 \text{ m/s}^*$											
$\cup 630$	$-5,00 \times 10^{-02}$	$2,70 \times 10^{-02}$									
800		$2,97 \times 10^{-02}$									
1 000	$-2,09 \times 10^{-02}$	$2,85 \times 10^{-02}$	$1,18 \times 10^{-04}$								
1 250	$-1,55 \times 10^{-02}$	$2,77 \times 10^{-02}$	$2,15 \times 10^{-04}$								
1 600	$9,06 \times 10^{-01}$	$2,88 \times 10^{-02}$	$2,82 \times 10^{-04}$								
2 000	1,46	$4,87 \times 10^{-02}$	$1,73 \times 10^{-04}$								
2 500	1,36	$7,05 \times 10^{-02}$	$4,54 \times 10^{-04}$	$-3,45 \times 10^{-06}$							
3 150	2,11	$7,77 \times 10^{-02}$	$8,23 \times 10^{-04}$	$-3,44 \times 10^{-06}$							
4 000	3,20	$8,59 \times 10^{-02}$	$1,01 \times 10^{-03}$								
5 000	3,62	$1,17 \times 10^{-01}$	$2,25 \times 10^{-03}$	$-4,72 \times 10^{-06}$	$-2,70 \times 10^{-07}$						
6 300	4,52	$1,53 \times 10^{-01}$	$3,20 \times 10^{-03}$	$-1,32 \times 10^{-05}$	$-4,71 \times 10^{-07}$						
8 000	5,69	$2,00 \times 10^{-01}$	$5,87 \times 10^{-03}$	$-4,17 \times 10^{-05}$	$-2,11 \times 10^{-06}$	$3,96 \times 10^{-09}$	$2,71 \times 10^{-10}$				
10 000	6,46	$2,56 \times 10^{-01}$	$1,03 \times 10^{-02}$	$-1,03 \times 10^{-04}$	$-7,02 \times 10^{-06}$	$2,47 \times 10^{-08}$	$2,23 \times 10^{-09}$	$-1,97 \times 10^{-12}$	$-2,51 \times 10^{-13}$		
$ U \cup 40 \text{ m/s}$											
12 500	7,50	$3,17 \times 10^{-01}$	$1,56 \times 10^{-02}$	$-2,05 \times 10^{-04}$	$-1,43 \times 10^{-05}$	$6,27 \times 10^{-08}$	$4,57 \times 10^{-09}$				
16 000	8,62	$3,96 \times 10^{-01}$	$2,61 \times 10^{-02}$	$-4,93 \times 10^{-04}$	$-4,37 \times 10^{-05}$	$3,81 \times 10^{-07}$	$3,32 \times 10^{-08}$	$-1,01 \times 10^{-10}$	$-8,91 \times 10^{-12}$		
20 000	$1,02 \times 10^{+01}$	$4,85 \times 10^{-01}$	$3,07 \times 10^{-02}$	$-1,03 \times 10^{-03}$	$-5,43 \times 10^{-05}$	$1,56 \times 10^{-06}$	$4,12 \times 10^{-08}$	$-1,04 \times 10^{-09}$	$-1,10 \times 10^{-11}$	$2,51 \times 10^{-13}$	
Where an empty cell occurs in the table, the respective value of a_i shall be taken as zero.											
NOTE Compute the value of $C_{3,4}$ from the approximation											
$C_{3,4}(U) = \sum_{i=0}^{10} a_i U^i$											
where U is the mean flow velocity in metres per second. $U < 0$ for the inlet duct and $U > 0$ for the outlet duct.											
* In the frequency range covered by this International Standard (i.e. 50 Hz to 10 000 Hz), values for the coefficients a_i are given for the range of flow velocities covered by this International Standard, i.e. $ U \cup 40$, plus, for information only, for an extended range, $ U \cup 60$. Also for information only, values are given for an extended frequency range, 12 500 Hz to 20 000 Hz, for flow velocities $ U \cup 40$.											

Annex I (informative)

Test method for large ducted fans

The range of test duct diameters specified in this International Standard is from 0,15 m to 2,0 m. According to 5.2.3, the maximum fan inlet diameter is then 2,0 m and the maximum fan outlet diameter 2,39 m. If fans with even larger inlet or outlet diameters are to be tested, it is recommended here to use test duct diameters up to 7,1 m diameter. This allows to test fans up to 7,1 m inlet and 8,49 m outlet diameter.

The radial position of the microphone with the sampling tube in the test duct is $2r/d = 0,65$.

Values for the coefficients a_i necessary to compute the mean flow velocity-modal corrections $C_{3,4}$ according to Equation (3) are given in Tables I.1 to I.3 for the following diameter ranges of the test duct:

- 2,0 m < d < 3,55 m,
- 3,55 m $\leq d$ < 5,0 m,
- 5,0 m $\leq d \leq 7,1$ m.

Table I.1 — Values of coefficients a_i for the determination of the combined mean flow velocity and modal correction $C_{3,4}$ of the sampling tube for duct diameters $2,0 \text{ m} < d < 3,55 \text{ m}$

$a_p \text{ dB}\cdot\text{s}^i\cdot\text{m}^{-i}$											
$f, \text{ Hz}$	a_0	a_1	a_2	a_3	a_4	a_5	a_6	a_7	a_8	a_9	a_{10}
$ U \cup 60 \text{ m/s}^*$											
63	$-5,00 \times 10^{-02}$	$2,70 \times 10^{-02}$									
80	$-1,42$	$1,89 \times 10^{-02}$									
100	$-9,19 \times 10^{-01}$	$2,17 \times 10^{-02}$									
125	$-1,03$	$2,14 \times 10^{-02}$									
160	$-4,68 \times 10^{-01}$	$2,29 \times 10^{-02}$									
200	$2,49 \times 10^{-01}$	$2,43 \times 10^{-02}$									
250	$9,25 \times 10^{-01}$	$2,62 \times 10^{-02}$									
315	$9,53 \times 10^{-01}$	$2,80 \times 10^{-02}$									
400	$5,60 \times 10^{-01}$	$3,03 \times 10^{-02}$									
500	$1,76 \times 10^{-01}$	$3,20 \times 10^{-02}$									
630	$4,03 \times 10^{-01}$	$3,44 \times 10^{-02}$									
800	$7,75 \times 10^{-01}$	$4,00 \times 10^{-02}$									
1 000	$1,10$	$4,53 \times 10^{-02}$									
1 250	$1,59$	$5,27 \times 10^{-02}$	$6,89 \times 10^{-05}$								
1 600	$2,14$	$6,09 \times 10^{-02}$	$1,37 \times 10^{-04}$								
2 000	$2,78$	$7,10 \times 10^{-02}$	$2,31 \times 10^{-04}$								
2 500	$3,50$	$8,27 \times 10^{-02}$	$3,73 \times 10^{-04}$								
3 150	$4,31$	$1,07 \times 10^{-01}$	$5,70 \times 10^{-04}$	$-4,49 \times 10^{-06}$							
4 000	$5,41$	$1,28 \times 10^{-01}$	$7,90 \times 10^{-04}$	$-7,49 \times 10^{-06}$							
5 000	$5,91$	$1,56 \times 10^{-01}$	$1,72 \times 10^{-03}$	$-1,28 \times 10^{-05}$	$-2,31 \times 10^{-07}$						

Table I.1 (continued)

$a_i, \text{dB}\cdot\text{s}^i\cdot\text{m}^{-i}$											
f, Hz	a_0	a_1	a_2	a_3	a_4	a_5	a_6	a_7	a_8	a_9	a_{10}
$ U \cup 60 \text{ m/s}^*$											
6 300	6,82	1,93 $\times 10^{-01}$	2,30 $\times 10^{-03}$	- 3,13 $\times 10^{-05}$	- 3,91 $\times 10^{-07}$	2,68 $\times 10^{-09}$					
8 000	7,94	2,38 $\times 10^{-01}$	4,19 $\times 10^{-03}$	- 6,07 $\times 10^{-05}$	- 1,76 $\times 10^{-06}$	8,14 $\times 10^{-09}$	2,55 $\times 10^{-10}$				
10 000	8,84	2,98 $\times 10^{-01}$	4,80 $\times 10^{-03}$	- 1,37 $\times 10^{-04}$	- 2,15 $\times 10^{-06}$	4,34 $\times 10^{-08}$	3,29 $\times 10^{-10}$	- 5,01 $\times 10^{-12}$			
$ U \cup 40 \text{ m/s}^*$											
12 500	9,55	3,60 $\times 10^{-01}$	9,60 $\times 10^{-03}$	- 2,24 $\times 10^{-04}$	- 9,44 $\times 10^{-06}$	7,27 $\times 10^{-08}$	3,17 $\times 10^{-09}$				
16 000	1,05 $\times 10^{+01}$	4,52 $\times 10^{-01}$	1,54 $\times 10^{-02}$	- 5,13 $\times 10^{-04}$	- 2,73 $\times 10^{-05}$	4,00 $\times 10^{-07}$	2,16 $\times 10^{-08}$	- 1,12 $\times 10^{-10}$	- 5,94 $\times 10^{-12}$		
20 000	1,17 $\times 10^{+01}$	5,61 $\times 10^{-01}$	1,66 $\times 10^{-02}$	- 1,03 $\times 10^{-03}$	- 2,85 $\times 10^{-05}$	1,43 $\times 10^{-06}$	2,19 $\times 10^{-08}$	- 9,36 $\times 10^{-10}$	- 5,90 $\times 10^{-12}$	2,25 $\times 10^{-13}$	
Where an empty cell occurs in the table, the respective value of a_i shall be taken as zero.											
NOTE Compute the value of $C_{3,4}$ from the approximation											
$C_{3,4}(U) = \sum_{i=0}^{10} a_i U^i$											
where U is the mean flow velocity in metres per second. $U < 0$ for the inlet duct and $U > 0$ for the outlet duct.											
* In the frequency range covered by this International Standard (i.e. 50 Hz to 10 000 Hz), values for the coefficients a_i are given for the range of flow velocities covered by this International Standard, i.e. $ U \cup 40$, plus, for information only, for an extended range, $ U \cup 60$. Also for information only, values are given for an extended frequency range, 12 500 Hz to 20 000 Hz, for flow velocities $ U \cup 40$.											

Table I.2 — Values of coefficients a_i for the determination of the combined mean flow velocity and modal correction $C_{3,4}$ of the sampling tube for duct diameters 3,55 m $\leq d \leq$ 5 m

$a_i, \text{dB}\cdot\text{s}^i\cdot\text{m}^{-i}$											
f, Hz	a_0	a_1	a_2	a_3	a_4	a_5	a_6	a_7	a_8	a_9	a_{10}
$ U \leq 60 \text{ m/s}^*$											
≤ 40	$-5,00 \times 10^{-02}$	$2,70 \times 10^{-02}$									
50	-1,43	$1,86 \times 10^{-02}$									
63	$-9,76 \times 10^{-01}$	$2,10 \times 10^{-02}$									
80	-1,08	$2,05 \times 10^{-02}$									
100	$-5,78 \times 10^{-01}$	$2,15 \times 10^{-02}$									
125	$8,39 \times 10^{-02}$	$2,18 \times 10^{-02}$									
160	$6,93 \times 10^{-01}$	$2,26 \times 10^{-02}$									
200	$5,59 \times 10^{-01}$	$2,26 \times 10^{-02}$									
250	$3,21 \times 10^{-02}$	$2,42 \times 10^{-02}$									
315	$-2,65 \times 10^{-01}$	$2,74 \times 10^{-02}$									
400	$5,60 \times 10^{-02}$	$3,01 \times 10^{-02}$									
500	$9,69 \times 10^{-02}$	$3,19 \times 10^{-02}$									
630	$1,62 \times 10^{-01}$	$3,46 \times 10^{-02}$									
800	$5,51 \times 10^{-01}$	$4,03 \times 10^{-02}$									
1 000	$9,65 \times 10^{-01}$	$4,52 \times 10^{-02}$									
1 250	1,47	$5,30 \times 10^{-02}$	$7,00 \times 10^{-05}$								
1 600	2,06	$6,11 \times 10^{-02}$	$1,35 \times 10^{-04}$								
2 000	2,71	$7,12 \times 10^{-02}$	$2,30 \times 10^{-04}$								
2 500	3,45	$8,29 \times 10^{-02}$	$3,71 \times 10^{-04}$								
3 150	4,27	$1,07 \times 10^{-01}$	$5,68 \times 10^{-04}$	$-4,52 \times 10^{-06}$							
4 000	5,38	$1,28 \times 10^{-01}$	$7,87 \times 10^{-04}$	$-7,54 \times 10^{-06}$							
5 000	5,89	$1,56 \times 10^{-01}$	$1,71 \times 10^{-03}$	$-1,29 \times 10^{-05}$	$-2,31 \times 10^{-07}$						

Licensed copy: Lee Shau Kee Library, HKUST, Version correct as of 03/01/2015, (c) The British Standards Institution 2015

Table I.2 (continued)

$a_i, \text{dB}\cdot\text{s}^i\cdot\text{m}^{-i}$											
f, Hz	a_0	a_1	a_2	a_3	a_4	a_5	a_6	a_7	a_8	a_9	a_{10}
$ U \cup 60 \text{ m/s}^*$											
6 300	6,80	$1,94 \times 10^{-01}$	$2,30 \times 10^{-03}$	$-3,15 \times 10^{-05}$	$-3,90 \times 10^{-07}$	$2,71 \times 10^{-09}$					
8 000	7,93	$2,38 \times 10^{-01}$	$4,18 \times 10^{-03}$	$-6,09 \times 10^{-05}$	$-1,76 \times 10^{-06}$	$8,17 \times 10^{-09}$	$2,55 \times 10^{-10}$				
10 000	8,84	$2,98 \times 10^{-01}$	$4,78 \times 10^{-03}$	$-1,37 \times 10^{-04}$	$-2,14 \times 10^{-06}$	$4,35 \times 10^{-08}$	$3,28 \times 10^{-10}$	$-5,02 \times 10^{-12}$			
$ U \cup 40 \text{ m/s}^*$											
12 500	9,55	$3,60 \times 10^{-01}$	$9,57 \times 10^{-03}$	$-2,24 \times 10^{-04}$	$-9,41 \times 10^{-06}$	$7,29 \times 10^{-08}$	$3,16 \times 10^{-09}$				
16 000	$1,07 \times 10^{+01}$	$4,53 \times 10^{-01}$	$1,03 \times 10^{-02}$	$-5,13 \times 10^{-04}$	$-1,01 \times 10^{-05}$	$4,01 \times 10^{-07}$	$3,37 \times 10^{-09}$	$-1,12 \times 10^{-10}$			
20 000	$1,17 \times 10^{+01}$	$5,62 \times 10^{-01}$	$1,66 \times 10^{-02}$	$-1,03 \times 10^{-03}$	$-2,84 \times 10^{-05}$	$1,43 \times 10^{-06}$	$2,18 \times 10^{-08}$	$-9,37 \times 10^{-10}$	$-5,88 \times 10^{-10}$	$2,25 \times 10^{-10}$	
Where an empty cell occurs in the table, the respective value of a_i shall be taken as zero.											
NOTE Compute the value of $C_{3,4}$ from the approximation											
$C_{3,4}(U) = \sum_{i=0}^{10} a_i U^i$											
where U is the mean flow velocity in metres per second. $U < 0$ for the inlet duct and $U > 0$ for the outlet duct.											
* In the frequency range covered by this International Standard (i.e. 50 Hz to 10 000 Hz), values for the coefficients a_i are given for the range of flow velocities covered by this International Standard, i.e. $ U \cup 40$, plus, for information only, for an extended range, $ U \cup 60$. Also for information only, values are given for an extended frequency range, 12 500 Hz to 20 000 Hz, for flow velocities $ U \cup 40$.											

Licensed copy: Lee Shau Kee Library, HKUST, Version correct as of 03/01/2015, (c) The British Standards Institution 2015

Table I.3 — Values of coefficients a_i for the determination of the combined mean flow velocity and modal correction $C_{3,4}$ of the sampling tube for duct diameters $5 \text{ m} \leq d \leq 7,1 \text{ m}$

$a_i, \text{dB}\cdot\text{s}^i\cdot\text{m}^{-i}$											
f, Hz	a_0	a_1	a_2	a_3	a_4	a_5	a_6	a_7	a_8	a_9	a_{10}
$ U \leq 60 \text{ m/s}^*$											
≤ 24	$-5,0 \times 10^{-02}$	$2,70 \times 10^{-02}$									
31,5	$-9,19 \times 10^{-01}$	$2,06 \times 10^{-02}$									
40	$-1,27$	$1,95 \times 10^{-02}$									
50	$-8,35 \times 10^{-01}$	$2,15 \times 10^{-02}$									
63	$-1,06$	$2,01 \times 10^{-02}$									
80	$-1,73 \times 10^{-01}$	$2,08 \times 10^{-02}$									
100	$4,07 \times 10^{-01}$	$2,13 \times 10^{-02}$									
125	$5,14 \times 10^{-01}$	$2,05 \times 10^{-02}$									
160	$2,16 \times 10^{-02}$	$2,00 \times 10^{-02}$									
200	$-6,58 \times 10^{-01}$	$2,12 \times 10^{-02}$									
250	$-4,84 \times 10^{-01}$	$2,45 \times 10^{-02}$									
315	$-1,93 \times 10^{-01}$	$2,77 \times 10^{-02}$									
400	$-2,24 \times 10^{-01}$	$3,01 \times 10^{-02}$									
500	$-8,44 \times 10^{-02}$	$3,19 \times 10^{-02}$									
630		$3,46 \times 10^{-02}$									
800	$4,47 \times 10^{-01}$	$4,03 \times 10^{-02}$									
1 000	$8,80 \times 10^{-01}$	$4,53 \times 10^{-02}$									
1 250	1,40	$5,31 \times 10^{-02}$	$7,04 \times 10^{-05}$								
1 600	2,01	$6,12 \times 10^{-02}$	$1,34 \times 10^{-04}$								
2 000	2,67	$7,13 \times 10^{-02}$	$2,30 \times 10^{-04}$								
2 500	3,42	$8,30 \times 10^{-02}$	$3,71 \times 10^{-04}$								
3 150	4,25	$1,07 \times 10^{-01}$	$5,67 \times 10^{-04}$	$-4,52 \times 10^{-06}$							

Table I.3 (continued)

$a_i, \text{dB}\cdot\text{s}^i\cdot\text{m}^{-i}$											
f, Hz	a_0	a_1	a_2	a_3	a_4	a_5	a_6	a_7	a_8	a_9	a_{10}
$ U \cup 60 \text{ m/s}^*$											
4 000	5,36	$1,28 \times 10^{-01}$	$7,86 \times 10^{-04}$	$-7,55 \times 10^{-06}$							
5 000	5,88	$1,56 \times 10^{-01}$	$1,71 \times 10^{-03}$	$-1,29 \times 10^{-05}$	$-2,30 \times 10^{-07}$						
6 300	6,80	$1,94 \times 10^{-01}$	$2,30 \times 10^{-03}$	$-3,15 \times 10^{-05}$	$-3,90 \times 10^{-07}$	$2,72 \times 10^{-09}$					
8 000	7,92	$2,38 \times 10^{-01}$	$4,17 \times 10^{-03}$	$-6,10 \times 10^{-05}$	$-1,76 \times 10^{-06}$	$8,19 \times 10^{-09}$	$2,54 \times 10^{-10}$				
10 000	8,83	$2,98 \times 10^{-01}$	$4,77 \times 10^{-03}$	$-1,37 \times 10^{-04}$	$-2,13 \times 10^{-06}$	$4,37 \times 10^{-08}$	$3,27 \times 10^{-10}$	$-5,05 \times 10^{-12}$			
$ U \cup 40 \text{ m/s}^*$											
12 500	9,55	$3,60 \times 10^{-01}$	$9,56 \times 10^{-03}$	$-2,24 \times 10^{-04}$	$-9,40 \times 10^{-06}$	$7,29 \times 10^{-08}$	$3,16 \times 10^{-09}$				
16 000	$1,05 \times 10^{+01}$	$4,53 \times 10^{-01}$	$1,53 \times 10^{-02}$	$-5,14 \times 10^{-04}$	$-2,71 \times 10^{-05}$	$4,02 \times 10^{-07}$	$2,15 \times 10^{-08}$	$-1,12 \times 10^{-10}$	$-5,91 \times 10^{-12}$		
20 000	$1,16 \times 10^{+01}$	$5,62 \times 10^{-01}$	$2,26 \times 10^{-02}$	$-1,03 \times 10^{-03}$	$-6,09 \times 10^{-05}$	$1,43 \times 10^{-06}$	$8,19 \times 10^{-08}$	$-9,38 \times 10^{-10}$	$-5,07 \times 10^{-11}$	$2,25 \times 10^{-13}$	$1,16 \times 10^{-14}$
Where an empty cell occurs in the table, the respective value of a_i shall be taken as zero.											
NOTE Compute the value of $C_{3,4}$ from the approximation											
$C_{3,4}(U) = \sum_{i=0}^{10} a_i U^i$											
where U is the mean flow velocity in metres per second. $U < 0$ for the inlet duct and $U > 0$ for the outlet duct.											
* In the frequency range covered by this International Standard (i.e. 50 Hz to 10 000 Hz), values for the coefficients a_i are given for the range of flow velocities covered by this International Standard, i.e. $ U \cup 40$, plus, for information only, for an extended range, $ U \cup 60$. Also for information only, values are given for an extended frequency range, 12 500 Hz to 20 000 Hz, for flow velocities $ U \cup 40$.											

Annex J (informative)

Measurement of the swirl component

The use of the sampling tube is not recommended when the flow in the test duct has a swirl component such that the angle of the mean flow velocity relative to the duct axis is greater than 15° . The angle of swirl in the test duct at the microphone position may be readily determined by means of a Pitot probe.

The Pitot probe should be inserted into the test duct so that the head of the sensor is at the radial position at which the microphone will be installed. With the fan inoperative, the head of the sensor should be aligned so that it is parallel with the axis of the test duct and faces towards the direction of flow. This defines the reference direction for the determination of the swirl angle.

With the fan operating at a known steady flow rate, the probe should be rotated to sense the maximum total pressure. When the maximum total pressure has been identified, the angle of the probe relative to the reference direction defines the angle of the swirl.

The determination of swirl angle should be repeated over the entire range of flow rates at which noise measurements are to be made.

If the swirl angle is greater than 15° , a significant increase in the uncertainty of the measurement of sound pressure level is likely to occur.

As an alternative to the above, three-hole or five-hole Pitot tubes and other type of yawmeter may be used to determine the angle of swirl. These should be used in accordance with the manufacturer's instructions.

Bibliography

- [1] OSBORNE, W.C. Measurement of noise in fan ducts. *ASHRAE Trans.*, **70**, Paper No. 1888, 1964
- [2] HOLGERSSON, S. Development of an anechoic termination for fan noise measurements. *ASHRAE Trans.*, **74**, Part I, Part No. 2069, 1968
- [3] BOLLETER, U. and CROCKER, M.J. Research toward an in-duct fan sound power measuring system. *ASHRAE Trans.*, **76**, Part II, 1970, pp. 110-119
- [4] MYERS, G.H. Anechoic duct termination development using scale model theory. *J. Acoust. Soc. Am.*, **47**, 1970, p. 117
- [5] CREMER, L. The second annual Fairey lecture: The treatment of fans as black boxes. *J. Sound Vib.*, **16**, 1971, pp. 1-15
- [6] SHENODA, F.B. *Reflexionsarme Abschlüsse für durchströmte Kanäle, Akustik und Schwingungstechnik*. VDE-Verlag GmbH, Berlin, 1972, p. 269
- [7] CROCKER, M.J., COHEN, R. and WANG, J.S. Recent developments in the design of tubular microphone windscreen for in-duct fan sound power measurements. *Inter-Noise, 73, Proceedings, Copenhagen*, pp. 594-598, August 1973
- [8] NEISE, W. *Einfluß der Mikrophonumströmung bei der Messung von Ventilatorgeräuschen im angeschlossenen Kanal*, Dissertation; Techn. Universität Berlin, also DLR-PB Report 74-04, 1973
- [9] BOLLETER, U., COHEN, R. and WANG, J.S. Design considerations for an in-duct sound power measuring system, *J. Sound Vib.*, **28**(4), pp. 669-685, 1973
- [10] WANG, J.S. and CROCKER, M.J. Tubular windscreen design for microphones for in-duct fan sound power measurements, *J. Acoust. Soc. Am.*, **55**(3), pp. 568-575, 1974
- [11] NEISE, W. and STAHL, B. The flow noise level of microphones in flow ducts, *J. Sound Vib.*, **63**, 1979, pp. 561-579
- [12] BOLTON, A.N. and MARGETTS, E.J. Anechoic terminations for in-duct fan noise measurement. *International Conference on Fan Design and Applications, Guildford, England, Sept. 7-9*, pp. 311-325
- [13] NEISE, W. Application of similarity laws to the blade passage sound of centrifugal fans. *J. Sound Vib.*, **43**, 1975, pp. 61-75
- [14] WOLLHERR, H. *Akustische Untersuchungen an Radialventilatoren unter Verwendung der Vierpoltheorie*. Ph. D. Dissertation, Techn. Universität Berlin, 1973
- [15] BAADE, P.K. Effects of acoustic loading on axial flow fan noise generation. *Noise Control Engineering*, **8** (1), 1977, pp. 5-15
- [16] NEISE, W. Theoretical and experimental investigations of microphone probes for sound measurements in turbulent flow. *J. Sound Vib.*, **39**(3), 1975, pp. 371-400
- [17] ROLAND, J. Evaluation of the errors in the measurements of silencer characteristics. *J. Sound Vib.*, **74**(4), 1981, pp. 549-558
- [18] NEISE, W., HOPPE, G. and HERRMANN, I.W. Geräuschmessungen an Ventilatoren. *Heizung, Lüftung, Haustechnik*, **38**, 1987, pp. 343-351

- [19] BOLTON, A. N. *Report on intercomparison tests to assess the accuracy and repeatability of in-duct fan noise measurement for Community Bureau of Reference*. Commission of the European Communities, Brussels, 1989
- [20] CHUNG, J.Y. and BLASER, D.A. Transfer function method of measuring in-duct acoustic properties (Part 1 and Part 2), *J. Acoust. Soc. Am.*, **68**, 1980, pp. 907-921
- [21] ARNOLD, F., MICHALKE, A. and NEISE, W. Zur Schalleistungsmessung in Strömungskanälen mit Schlitzrohrsonden, *Fortschritte der Akustik — DAGA'95, Bad Honnef*. DPG GmbH 1995, S. 531-534
- [22] ARNOLD, F., MICHALKE, A. and NEISE, W. Berechnung neuer Korrekturwerte für die Schalleistungsmessung nach dem Kanal-Verfahren DIN EN 25136. *Deutsche Forschungsanstalt für Luft und Raumfahrt e.V. DLR IB 92517-96/B2* (1996)
- [23] MICHALKE, A., ARNOLD, F. and HOLSTE, F. On the Coherence of the Sound Field in a Circular Duct with Uniform Mean Flow, *J. Sound Vib.*, **190**(2), 1996, pp. 261-271
- [24] ARNOLD, F. Experimentelle und numerische Untersuchung zur Schalleleistungsbestimmung in Strömungskanälen. *VDI-Fortschritt-Berichte, Reihe 7 Strömungstechnik Nr. 353*, 1999 (Dissertation, TU-Berlin, Juli 1998)
- [25] ARNOLD, F. A cross correlation method for sound power determination in flow ducts and frequency corrections for the standardized in-duct method, *6th International Congress of Sound and Vibration*, Technical University of Denmark, Lyngby, Denmark, 5-8 July 1999
- [26] NEISE, W. On sound power determination in flow ducts. *6th International Congress of Sound and Vibration*, Technical University of Denmark, Lyngby, Denmark, 5-8 July 1999, Specialist Keynote Paper
- [27] BROCK, M. Wind and turbulence noise of turbulence screen, nose cone, and sound intensity probe with wind screen. *B&K Technical Review*, No. 4, 1986, pp. 32-39
- [28] ISO 3740, *Acoustics — Determination of sound power levels of noise sources — Guidelines for the use of basic standards*
- [29] ISO 3741, *Acoustics — Determination of sound power levels of noise sources using sound pressure — Precision methods for reverberation rooms*
- [30] ISO 3743-1, *Acoustics — Determination of sound power levels of noise sources — Engineering methods for small, movable sources in reverberant fields — Part 1: Comparison method for hard-walled test rooms*
- [31] ISO 3743-2, *Acoustics — Determination of sound power levels of noise sources using sound pressure — Engineering methods for small, movable sources in reverberant fields — Part 2: Methods for special reverberation test rooms*
- [32] ISO 3744, *Acoustics — Determination of sound power levels of noise sources using sound pressure — Engineering method in an essentially free field over a reflecting plane*
- [33] ISO 3745, *Acoustics — Determination of sound power levels of noise sources using sound pressure — Precision methods for anechoic and hemi-anechoic rooms*
- [34] ISO 3746, *Acoustics — Determination of sound power levels of noise sources using sound pressure — Survey method using an enveloping measurement surface over a reflecting plane*
- [35] ISO 7235, *Acoustics — Laboratory measurement procedures for ducted silencers and air-terminal units — Insertion loss, flow noise and total pressure loss*

- [36] ISO 7574-1, *Acoustics — Statistical methods for determining and verifying stated noise emission values of machinery and equipment — Part 1: General considerations and definitions*
- [37] ISO 7574-3, *Acoustics — Statistical methods for determining and verifying stated noise emission values of machinery and equipment — Part 3: Simple (transition) method for stated values for batches of machines*
- [38] ISO 7574-4, *Acoustics — Statistical methods for determining and verifying stated noise emission values of machinery and equipment — Part 4: Methods for stated values for batches of machines*
- [39] ISO 9614 (all parts), *Acoustics — Determination of sound power levels of noise sources using sound intensity*
- [40] DAVY, J.L., BAADE, P.K., HALVARSON, J.H. An improved sampling tube for induct fan sound measurement. *2nd International Symposium on Fan Noise*, Senlis, France, 23-25 September 2003
- [41] VON HEESEN, W. The use of the turbulence screen for in-duct-measurement of the sound power of large axial-flow fans. *6th International Congress of Sound and Vibration*, Technical University of Denmark, Lyngby, Denmark, 5-8 July 1999

BSI - British Standards Institution

BSI is the independent national body responsible for preparing British Standards. It presents the UK view on standards in Europe and at the international level. It is incorporated by Royal Charter.

Revisions

British Standards are updated by amendment or revision. Users of British Standards should make sure that they possess the latest amendments or editions.

It is the constant aim of BSI to improve the quality of our products and services. We would be grateful if anyone finding an inaccuracy or ambiguity while using this British Standard would inform the Secretary of the technical committee responsible, the identity of which can be found on the inside front cover. Tel: +44 (0)20 8996 9000. Fax: +44 (0)20 8996 7400.

BSI offers members an individual updating service called PLUS which ensures that subscribers automatically receive the latest editions of standards.

Buying standards

Orders for all BSI, international and foreign standards publications should be addressed to Customer Services. Tel: +44 (0)20 8996 9001. Fax: +44 (0)20 8996 7001 Email: orders@bsigroup.com You may also buy directly using a debit/credit card from the BSI Shop on the Website <http://www.bsigroup.com/shop>

In response to orders for international standards, it is BSI policy to supply the BSI implementation of those that have been published as British Standards, unless otherwise requested.

Information on standards

BSI provides a wide range of information on national, European and international standards through its Library and its Technical Help to Exporters Service. Various BSI electronic information services are also available which give details on all its products and services. Contact Information Centre. Tel: +44 (0)20 8996 7111 Fax: +44 (0)20 8996 7048 Email: info@bsigroup.com

Subscribing members of BSI are kept up to date with standards developments and receive substantial discounts on the purchase price of standards. For details of these and other benefits contact Membership Administration. Tel: +44 (0)20 8996 7002 Fax: +44 (0)20 8996 7001 Email: membership@bsigroup.com

Information regarding online access to British Standards via British Standards Online can be found at <http://www.bsigroup.com/BSOL>

Further information about BSI is available on the BSI website at <http://www.bsigroup.com>.

Copyright

Copyright subsists in all BSI publications. BSI also holds the copyright, in the UK, of the publications of the international standardization bodies. Except as permitted under the Copyright, Designs and Patents Act 1988 no extract may be reproduced, stored in a retrieval system or transmitted in any form or by any means – electronic, photocopying, recording or otherwise – without prior written permission from BSI.

This does not preclude the free use, in the course of implementing the standard, of necessary details such as symbols, and size, type or grade designations. If these details are to be used for any other purpose than implementation then the prior written permission of BSI must be obtained.

Details and advice can be obtained from the Copyright and Licensing Manager. Tel: +44 (0)20 8996 7070 Email: copyright@bsigroup.com