

Plastics — Determination of burning behaviour by oxygen index —

Part 3: Elevated-temperature test

The European Standard EN ISO 4589-3:1996 has the status of a British Standard

ICS 83.080.01

Committees responsible for this British Standard

The preparation of this British Standard was entrusted to Technical Committee PRI/26, Burning behaviour of plastics and rubbers, upon which the following bodies were represented:

Association of Building Component Manufacturers
 Association of Manufacturers of Domestic Electrical Appliances
 British Cable Makers' Confederation
 British Electrical Systems Association (BEAMA Ltd.)
 British Plastics Federation
 British Railways Board
 Department of the Environment (Building Research Establishment)
 ERA Technology Ltd.
 Electrical and Electronic Insulation Association (BEAMA Ltd.)
 Electrical Installation Equipment Manufacturers' Association (BEAMA Ltd.)
 Electricity Association
 Federation of the Electronics Industry
 GAMBICA (BEAMA Ltd.)
 Lighting Industry Federation Ltd.
 Ministry of Defence
 National Supervising Inspectorate
 RAPRA Technology Ltd.
 Society of British Aerospace Companies Limited
 University of Ulster
 Warrington Fire Research Centre

This British Standard, having been prepared under the direction of the Sector Board for Materials and Chemicals, was published under the authority of the Standards Board and comes into effect on 15 December 1996

© BSI 10-1998

The following BSI references relate to the work on this standard:
 Committee reference PRI/26
 Draft for comment 94/300871 DC

ISBN 0 580 26770 9

Amendments issued since publication

Amd. No.	Date	Comments

Contents

	Page
Committees responsible	Inside front cover
National foreword	ii
<hr/>	
Foreword	2
Introduction	3
1 Scope	3
2 Normative reference	3
3 Definitions	3
4 Principle	3
5 Apparatus	4
6 Calibration and maintenance of equipment	4
7 Preparation of test specimens	5
8 Procedure	5
9 Calculations and expression of results	5
10 Procedure C — Comparison with a specified minimum value of the oxygen index at a specified temperature (short procedure)	6
11 Precision	6
12 Test report	6
<hr/>	
Annex A (normative) Measurement of flammability temperature (FT)	14
Annex B (informative) Inter laboratory test data on flammability temperature	15
Annex C (informative) Typical test results sheet	16
<hr/>	
Figure 1 — Diagram of typical apparatus for determination of oxygen index at elevated temperature	7
Figure 2 — Diagram of typical heated chimney	8
Figure 3 — Diagram of typical form of preheater and base of assembly for test chimney	9
Figure 4 — Diagram of typical chimney outlet restrictor	10
Figure 5 — Design of support frame for non-self-supporting test specimens	11
Figure 6 — Diagram of typical specimen-holder transfer tool	12
Figure 7 — Details of test specimen support	13
<hr/>	
Table B.1 — Summary of round-robin results	15
Table C.1 — Values of k for calculating the oxygen index concentration from determinations made by Dixon's "up-and-down method"	17
<hr/>	

National foreword

This British Standard has been prepared by Technical Committee PRI/26 and is the English language version of EN ISO 4589-3:1996 *Plastics — Determination of burning behaviour by oxygen index — Part 3: Elevated-temperature test* published by the European Committee for Standardization (CEN).

It should be used in conjunction with BS ISO 4589-2:1996 *Plastics — Determination of burning behaviour by oxygen index — Part 2: Ambient temperature test*.

Annex A of BS EN ISO 4589-3:1996 supersedes BS 2782-1: Methods 143A and 143B:1989 which are withdrawn.

A British Standard does not purport to include all the necessary provisions of a contract. Users of British Standards are responsible for their correct application.

Compliance with a British Standard does not of itself confer immunity from legal obligations.

Summary of pages

This document comprises a front cover, an inside front cover, pages i and ii, the EN title page, pages 2 to 18 and a back cover.

This standard has been updated (see copyright date) and may have had amendments incorporated. This will be indicated in the amendment table on the inside front cover.

ICS 83.080

Descriptors: Plastics, tests, physical tests, fire tests, flammability testing, determination, oxygen index, test equipment

English version

Plastics — Determination of burning behaviour by
oxygen index —
Part 3: Elevated-temperature test

(ISO 4589-3:1996)

Plastiques — Détermination du comportement au
feu au moyen de l'indice d'oxygène —
Partie 3: Essai à haute température
(ISO 4589-3:1996)

This European Standard was approved by CEN on 1996-07-04. CEN members are bound to comply with the CEN/CENELEC Internal Regulations which stipulate the conditions for giving this European Standard the status of a national standard without any alteration.

Up-to-date lists and bibliographical references concerning such national standards may be obtained on application to the Central Secretariat or to any CEN member.

This European Standard exists in three official versions (English, French, German). A version in any other language made by translation under the responsibility of a CEN member into its own language and notified to the Central Secretariat has the same status as the official versions.

CEN members are the national standards bodies of Austria, Belgium, Denmark, Finland, France, Germany, Greece, Iceland, Ireland, Italy, Luxembourg, Netherlands, Norway, Portugal, Spain, Sweden, Switzerland and United Kingdom.

CEN

European Committee for Standardization
Comité Européen de Normalisation
Europäisches Komitee für Normung

Central Secretariat: rue de Stassart 36, B-1050 Brussels

Foreword

The text of the International Standard ISO 4589-3:1996 has been prepared by Technical Committee ISO/TC 61, Plastics, in collaboration with Technical Committee CEN/TC 249, Plastics, the secretariat of which is held by IBN.

This European Standard shall be given the status of a national standard, either by publication of an identical text or by endorsement, at the latest by February 1997, and conflicting national standards shall be withdrawn at the latest by February 1997.

According to the CEN/CENELEC Internal Regulations, the national standards organizations of the following countries are bound to implement this European Standard: Austria, Belgium, Denmark, Finland, France, Germany, Greece, Iceland, Ireland, Italy, Luxembourg, Netherlands, Norway, Portugal, Spain, Sweden, Switzerland and the United Kingdom.

Introduction

This part of ISO 4589 has been prepared to extend the methods available for the determination of flammability by oxygen index (see ISO 4589-2) to typical elevated temperatures to which a plastic material can be exposed in a service situation. It also provides a method for determining the temperature at which combustion of a small bar of material is just supported in air under certain test conditions; the resulting temperature is termed the flammability temperature.

This part of ISO 4589 is intended to be used in conjunction with ISO 4589-2 which describes the basic oxygen index test method.

1 Scope

This part of ISO 4589 specifies methods for determining the minimum concentration of oxygen, in a mixture with nitrogen, that will support combustion of small vertical test specimens under specified test conditions over a range of temperatures typically between 25 °C and 150 °C. The results are defined as oxygen index values at the test temperature, which is typical of the practical temperature that a plastic material may experience in an overheated service situation.

Methods are provided for testing materials that are self-supporting at the test temperature in the form of vertical bars or sheet up to 10,5 mm thick. These methods are suitable for solid, laminated or cellular materials characterized by an apparent density greater than 100 kg/m³. The methods may also be applicable to some cellular materials having an apparent density of less than 100 kg/m³. A method is provided for testing flexible sheet or film materials while supported vertically.

This part of ISO 4589 also includes a method (see annex A) for determining the temperature at which the oxygen index of small vertical test specimens in air is 20,9 under specified test conditions. The result is defined as the flammability temperature (FT) and the method is limited to the determination of results less than 400 °C. The method is not applicable to materials having an oxygen index of <20,9 when measured at 23 °C.

Results obtained in accordance with this part of ISO 4589 should not be used to describe or appraise the fire hazard presented by a particular material or shape under actual fire conditions, unless used as one element of a fire risk assessment which takes into account all of the factors which are pertinent to the assessment of the fire hazard of a particular application for the material.

NOTE 1 It may not be possible to apply these methods satisfactorily to materials that exhibit high levels of shrinkage when heated, e.g. highly oriented thin film.

NOTE 2 For assessing the flame propagation properties of cellular materials of density <100 kg/m³, attention is drawn to the method of ISO 3582:1978, *Cellular plastic and cellular rubber materials — Laboratory assessment of horizontal burning characteristics of small specimens subjected to a small flame*.

2 Normative reference

The following standard contains provisions which, through reference in this text, constitute provisions of this part of ISO 4589. At the time of publication, the edition indicated was valid. All standards are subject to revision, and parties to agreements based on this part of ISO 4589 are encouraged to investigate the possibility of applying the most recent edition of the standard indicated below. Members of IEC and ISO maintain registers of currently valid International Standards.

ISO 4589-2:1996, *Plastics — Determination of burning behaviour by oxygen index — Part 2: Ambient-temperature test*.

3 Definitions

For the purposes of this part of ISO 4589, the following definitions apply.

3.1

flammability temperature (FT)

the temperature at which combustion of a material is just supported in air under specified test conditions

3.2

oxygen index at elevated temperature

the minimum concentration of oxygen, by volume percentage, in a mixture of oxygen and nitrogen, introduced at an agreed test temperature of greater than 25 °C, that will just support combustion of a material under specified test conditions

3.3

ignition

the initiation of flaming combustion

4 Principle

A small test specimen is supported vertically in a mixture of oxygen and nitrogen flowing upwards through a transparent heated chimney. The upper end of the specimen is ignited and the subsequent burning behaviour of the specimen is observed to compare the period for which burning continues, or the length of specimen burnt, with specified limits for such burning. By testing a series of specimens in different oxygen concentrations, the minimum oxygen concentration is estimated.

5 Apparatus

5.1 Arrangement. The apparatus specified in **5.2** to **5.5** shall be arranged as indicated by the diagrams in Figure 1 to Figure 4, as appropriate.

5.2 Test chimney, consisting of two concentric heat-resistant glass tubes supported vertically between an insulating top plate and a base through which oxygen-containing gas mixtures can be introduced. The chimney is provided with a heating element suitable for use, in conjunction with a preheater for heating the incoming gas mixture, to maintain the test atmosphere within the inner tube in the vicinity of the test specimen at within ± 2 °C of any specific test temperature up to and including 125 °C and at within ± 3 °C of any higher test temperature at which the equipment is intended to be used. The heating element shall not impede adequate observation of a test specimen under test.

The preferred dimensions of the inner tube are 450 mm minimum height and 75 mm minimum-diameter cylindrical bore. The upper outlet should preferably be restricted as necessary by an overhead cap having an outlet small enough to produce an exhaust velocity of at least 90 mm/s from a flow rate within the chimney of 40 mm/s (see note 3). The height of the outer tube should be similar to that of the inner tube and the radial clearance between the inner and outer tubes should be between 5 mm and 10 mm. Chimneys of other dimensions, with or without restricted outlets, may be used, if shown to give equivalent results.

The bottom of the chimney, or the base upon which the chimney is supported, shall incorporate a means for distributing evenly the gas mixture entering the inner tube. A satisfactory means comprises beads of diameter between 3 mm and 5 mm, in a layer between 80 mm and 100 mm deep. Other devices, such as radial manifolds, may be used, if shown to give equivalent results.

A porous screen may be mounted below the level of the test piece holder, to prevent falling combustion debris from fouling the gas entry and distribution paths.

The chimney support may incorporate a levelling device and indicator, to facilitate vertical alignment of the chimney and a test piece supported therein. A dark background may be provided, to facilitate observation of flames within the chimney.

NOTE 3 For inner tubes of diameter 75 mm to 100 mm, a cap converging to an outlet of diameter 40 mm at a level at least 10 mm above the top of the cylindrical chimney has been found satisfactory. For such tubes also, an electrical-resistance heating element dissipating up to about 1 000 W and helically wound about the outer surface of the tube with a graded distribution of winding pitch (the windings being closer together at the top) has been found suitable in conjunction with a preheater comprising a cylindrical ceramic body with longitudinal holes and containing a heating element dissipating up to about 1 000 W with regulating controls which can be operated separately from those of the heater windings on the chimney tube.

5.3 Test specimen holder, suitable for supporting a specimen vertically in the centre of the chimney, conforming to **5.2** of ISO 4589-2.

The holder may have a complementary tool of any suitable shape (see Figure 6) for moving a specimen or loaded specimen holder into or out of the test chimney.

5.4 Gas supplies, conforming to **5.3** of ISO 4589-2.

NOTE 4 Because damage may occur to the chimney heater and preheater if energized while no gas flows through them, it is recommended that a gas-flow or pressure-sensing device is incorporated in the gas supply lines and is coupled to the heater power-control circuits.

NOTE 5 To economize purified oxygen and nitrogen, it is recommended that an air pump is provided to supply air instead of oxygen and/or nitrogen, at the appropriate flow rate, during periods when specimens are not being tested.

5.5 Gas measurement and control devices, suitable for measuring the concentration of oxygen in the gas mixture entering the chimney with an accuracy of $\pm 0,5$ % (V/V) of the mixture and for adjusting the concentration with a precision of $\pm 0,1$ % (V/V) of the mixture.

Means shall be provided for checking or ensuring that the temperature of the gas mixture in the chimney is in accordance with **5.2**. If this involves an internal probe, its position and profile shall be designed to minimize induction of turbulence within the chimney.

NOTE 6 Systems of measurement and control that have proved satisfactory are listed in **5.4** of ISO 4589-2.

5.6 Flame igniter, conforming to **5.5** of ISO 4589-2.

5.7 Timing device, capable of measuring periods up to 5 min with an accuracy of $\pm 0,5$ s.

5.8 Fume extraction system, conforming to **5.7** of ISO 4589-2.

6 Calibration and maintenance of equipment

Calibrate and maintain the equipment periodically in accordance with the instructions given in annex A of ISO 4589-2 so that the maximum interval between recalibration and use conforms to the periods stated in Table 1 of ISO 4589-2.

7 Preparation of test specimens

7.1 Sampling

Sampling shall be in accordance with 7.1 of ISO 4589-2.

For the flammability temperature procedure (see annex A), at least 10 test specimens shall be provided. If a test specimen is not self-supporting at the temperature of the test, it shall be provided with external support by the use of 0,55 mm \pm 0,05 mm diameter nickel-chromium alloy wire with a maximum working temperature of 1 100 °C and secured by ties of copper wire of 0,20 mm \pm 0,02 mm diameter. These shall be positioned as shown in Figure 7. See annex B for round-robin analysis of test specimen holder.

7.2 Test specimen dimensions and preparation

Test specimen dimensions shall conform to and specimen preparation shall be in accordance with 7.2 of ISO 4589-2.

7.3 Marking of test pieces

Marking of the test specimens shall be in accordance with 7.3 of ISO 4589-2.

7.4 Conditioning

Conditioning shall be in accordance with 7.4 of ISO 4589-2.

8 Procedure

8.1 Setting up the apparatus and test specimen

8.1.1 Position a temperature sensor in the position to be occupied by the top of a test specimen.

Adjust the electrical power to the chimney heater and preheater to give the test temperature, with the gas controls set to give a gas velocity through the chimney of 40 mm/s \pm 0,8 mm/s at 23 °C.

8.1.2 Select an initial concentration of oxygen to be used. When possible, base this on experience of results for similar materials. Alternatively, try to ignite a test specimen in air at the test temperature, and note the burning behaviour. If the specimen burns rapidly, select an initial concentration of about 18 % (V/V) of oxygen; if the test specimen burns gently or unsteadily, select an initial oxygen concentration of about 21 % (V/V); if the specimen does not continue to burn in air, select an initial concentration of at least 25 % (V/V), depending upon the difficulty of ignition or the period of burning before extinguishing in air.

8.1.3 When the temperature in the test chimney is stable and in accordance with the limits given in 5.2, mount a specimen in the centre of the chimney so that the top of the specimen is at least 100 mm below the open top of the chimney and the lowest exposed part of the specimen is at least 100 mm above the top of the gas distribution device at the base of the chimney.

8.1.4 Preheat the specimen for 240 s \pm 10 s for it to reach a temperature within the applicable test temperature tolerance before ignition.

8.1.5 Set the gas mixing and flow controls so that an oxygen/nitrogen mixture at 23 °C, containing the desired concentration of oxygen, flows through the chimney at 40 mm/s \pm 0,8 mm/s. Let the gas flow purge the chimney for at least 30 s prior to ignition of each specimen, and maintain the flow without change during ignition and combustion of each specimen.

Record the oxygen concentration used as the volume per cent calculated in accordance with the equations given in annex B of ISO 4589-2.

8.2 Igniting the test specimen

Ignite the specimen in accordance with 8.2 of ISO 4589-2, using procedure A or procedure B.

8.3 Assessing burning behaviour

The burning behaviour of individual test specimens shall be assessed in accordance with 8.3 of ISO 4589-2.

8.4 Selecting successive oxygen concentrations

The oxygen concentration required for the purpose of 8.4 to 8.6 shall be calculated in accordance with annex B of ISO 4589-2.

Select successive oxygen concentrations in accordance with 8.4 of ISO 4589-2.

8.5 Determining the preliminary oxygen concentration

Determine the preliminary oxygen concentration in accordance with 8.5 of ISO 4589-2.

8.6 Oxygen concentration changes

Make oxygen concentration changes in accordance with 8.6 of ISO 4589-2.

9 Calculations and expression of results

Calculate the oxygen index in accordance with 9.1 of ISO 4589-2 and determine k in accordance with 9.2 of ISO 4589-2. Determine the standard deviation of the oxygen concentration measurements in accordance with 9.3 of ISO 4589-2.

10 Procedure C — Comparison with a specified minimum value of the oxygen index at a specified temperature (short procedure)

Carry out the procedure in accordance with clause 10 of ISO 4589-2.

11 Precision

No precision data for these methods of test are currently available. Interlaboratory trials data are being obtained and it is intended that a precision statement be added at the first revision following their collation.

12 Test report

The test report shall include the following information:

- a) a reference to this part of ISO 4589;
- b) a statement that the test results relate only to the behaviour of the test specimens under the conditions of this test and that these results are not to be used to infer the fire hazards of the material in other forms or under other fire conditions;
- c) all details necessary for identification of the material tested, including, where relevant, the type of material, its density, its previous history and the specimen orientation with respect to any anisotropy in the material or sample;
- d) the test specimen form (I to VI) and dimensions;
- e) the method of specimen support, e.g. self-supporting or nickel-chromium alloy wire;
- f) the ignition procedure used (A or B), and the igniter used, if other than the standard propane flame;
- g) the oxygen index;
- h) the test temperature;
- i) the estimated standard deviation and the oxygen concentration increment used, if other than 0,2 % (V/V);
- j) a description of any relevant ancillary characteristics or behaviour such as charring, dripping, severe shrinkage, erratic burning or afterglow;
- k) any deviations from the requirements of this part of ISO 4589.

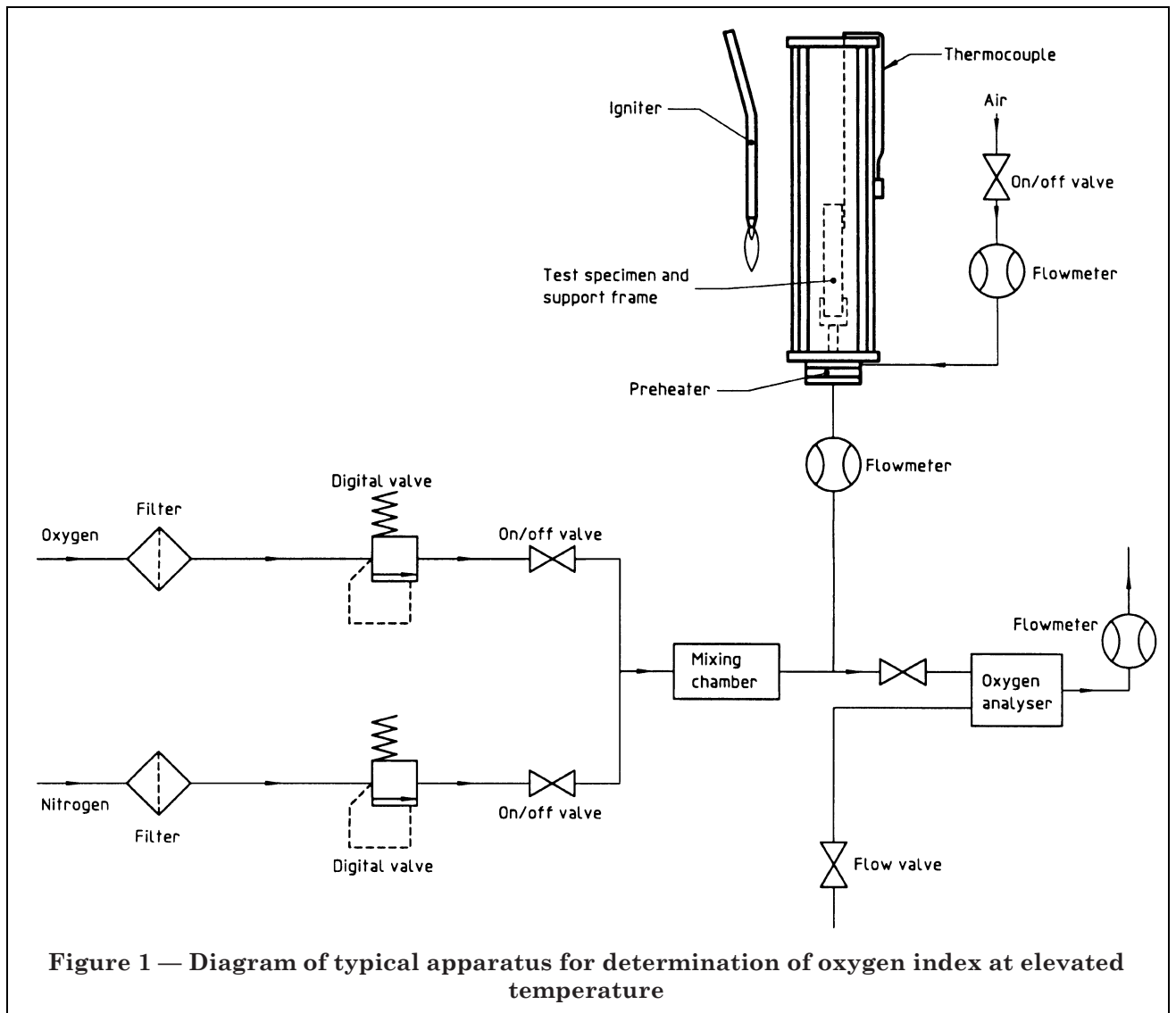

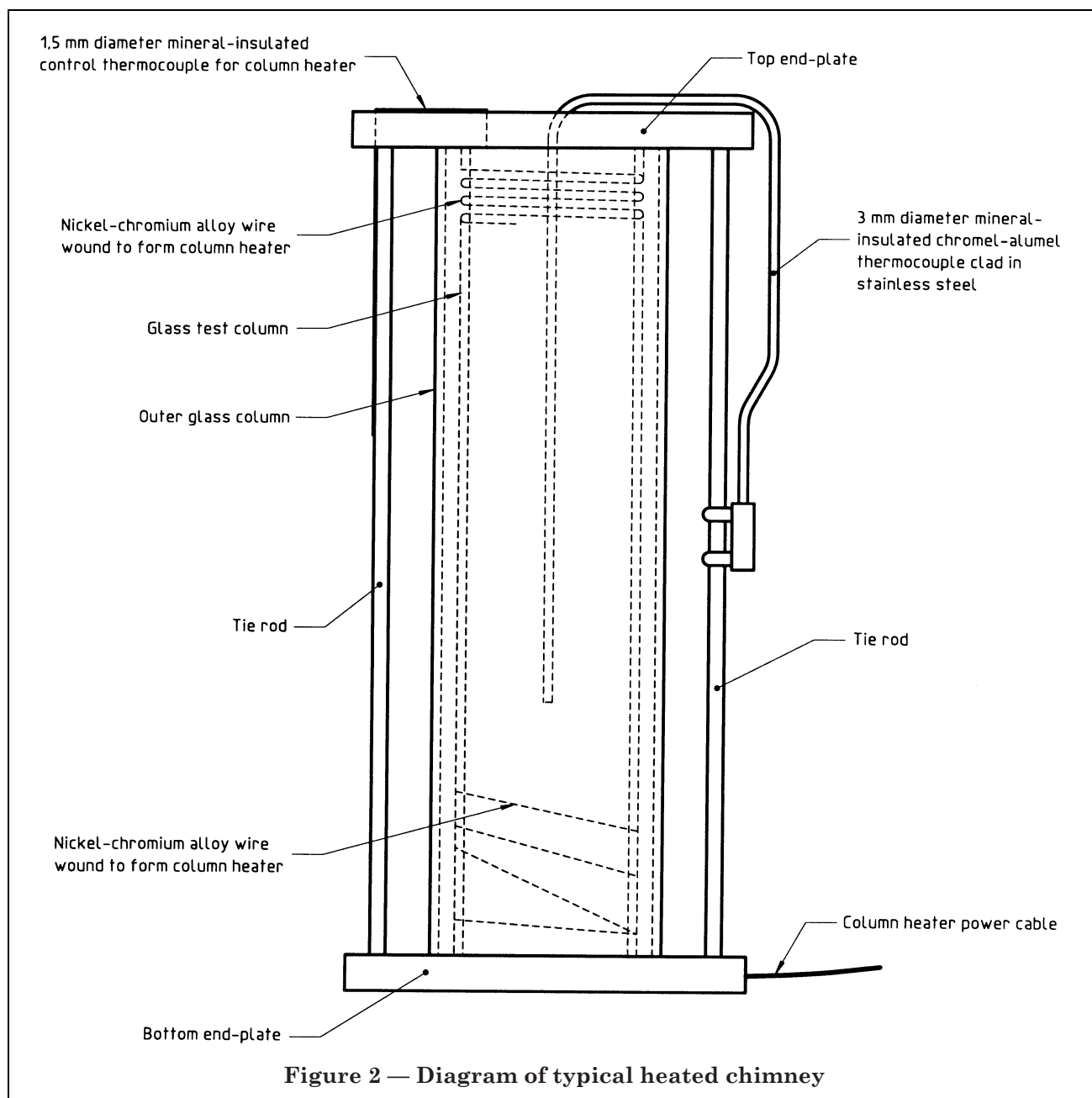

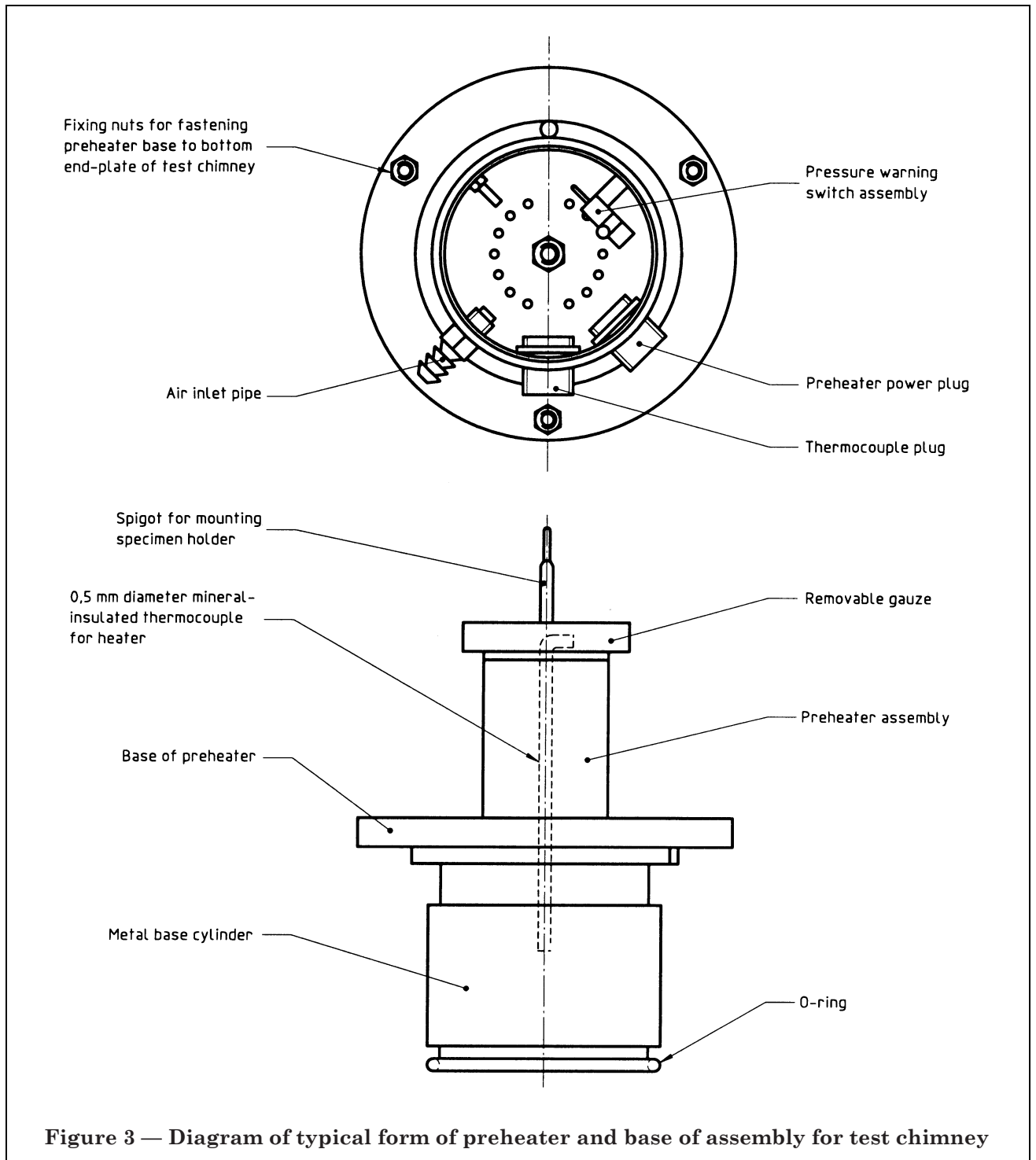
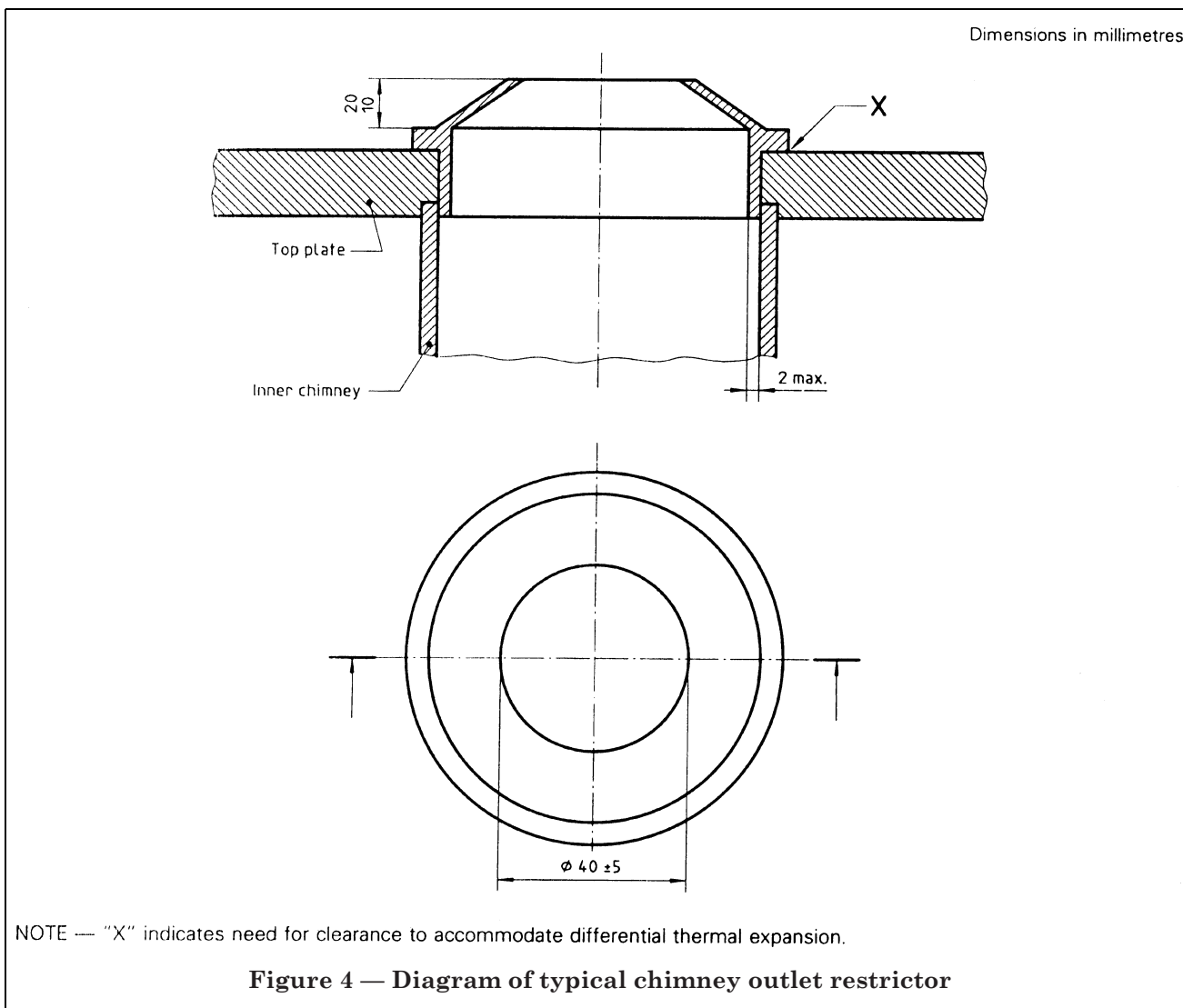
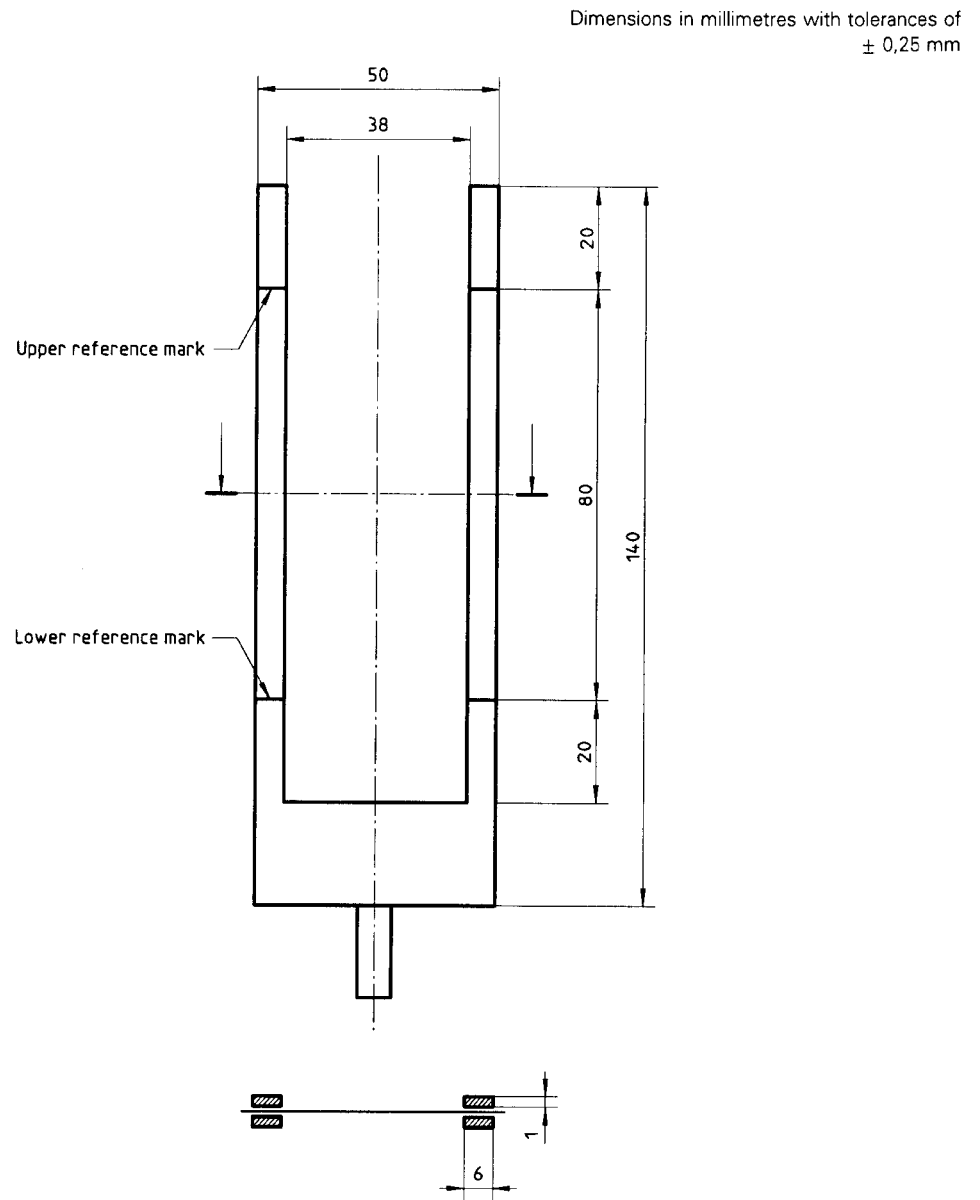

Figure 3 — Diagram of typical form of preheater and base of assembly for test chimney





NOTE — Frame sections shall hold the test specimen securely along both upright edges between forks made of stainless steel.

Figure 5 — Design of support frame for non-self-supporting test specimens

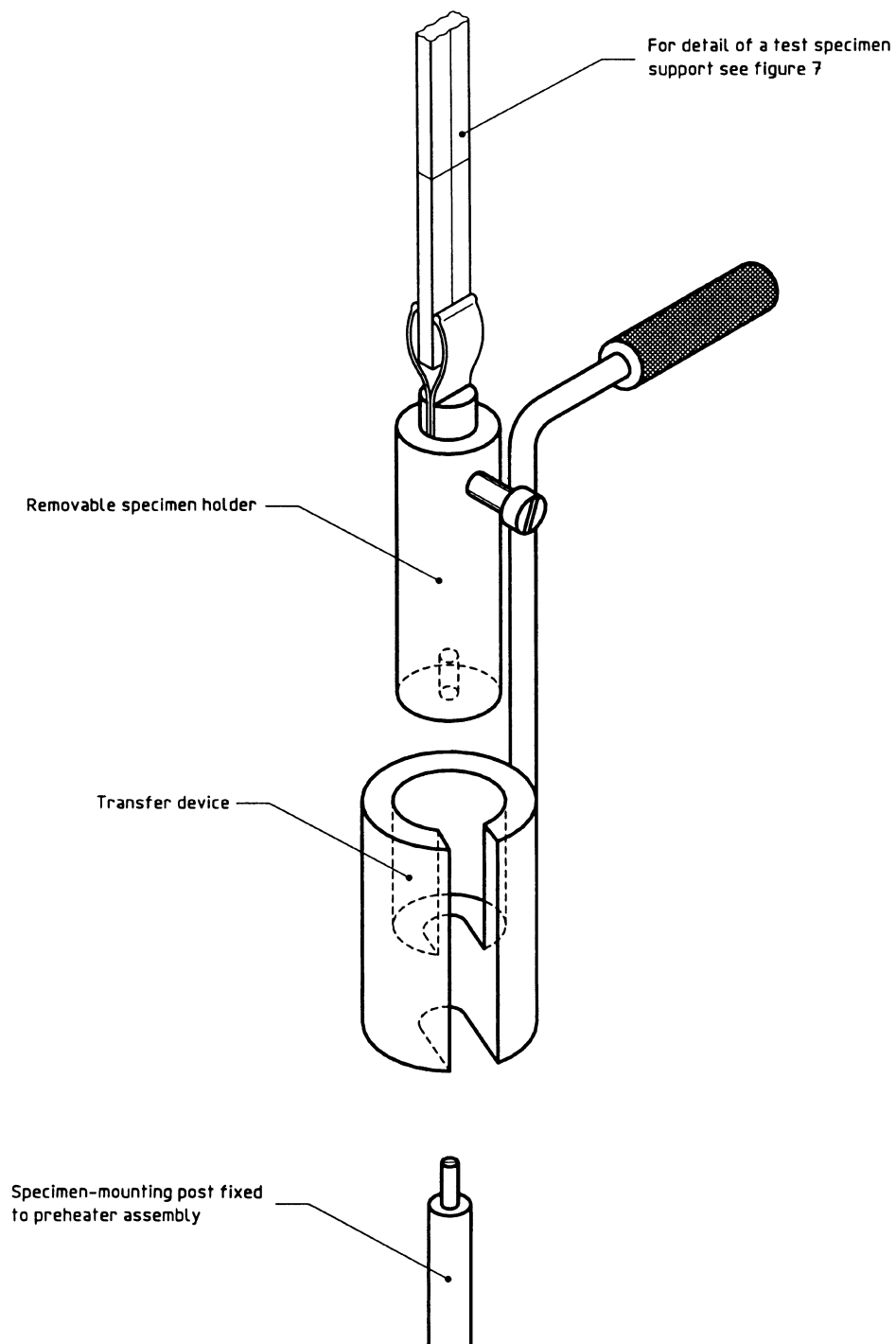
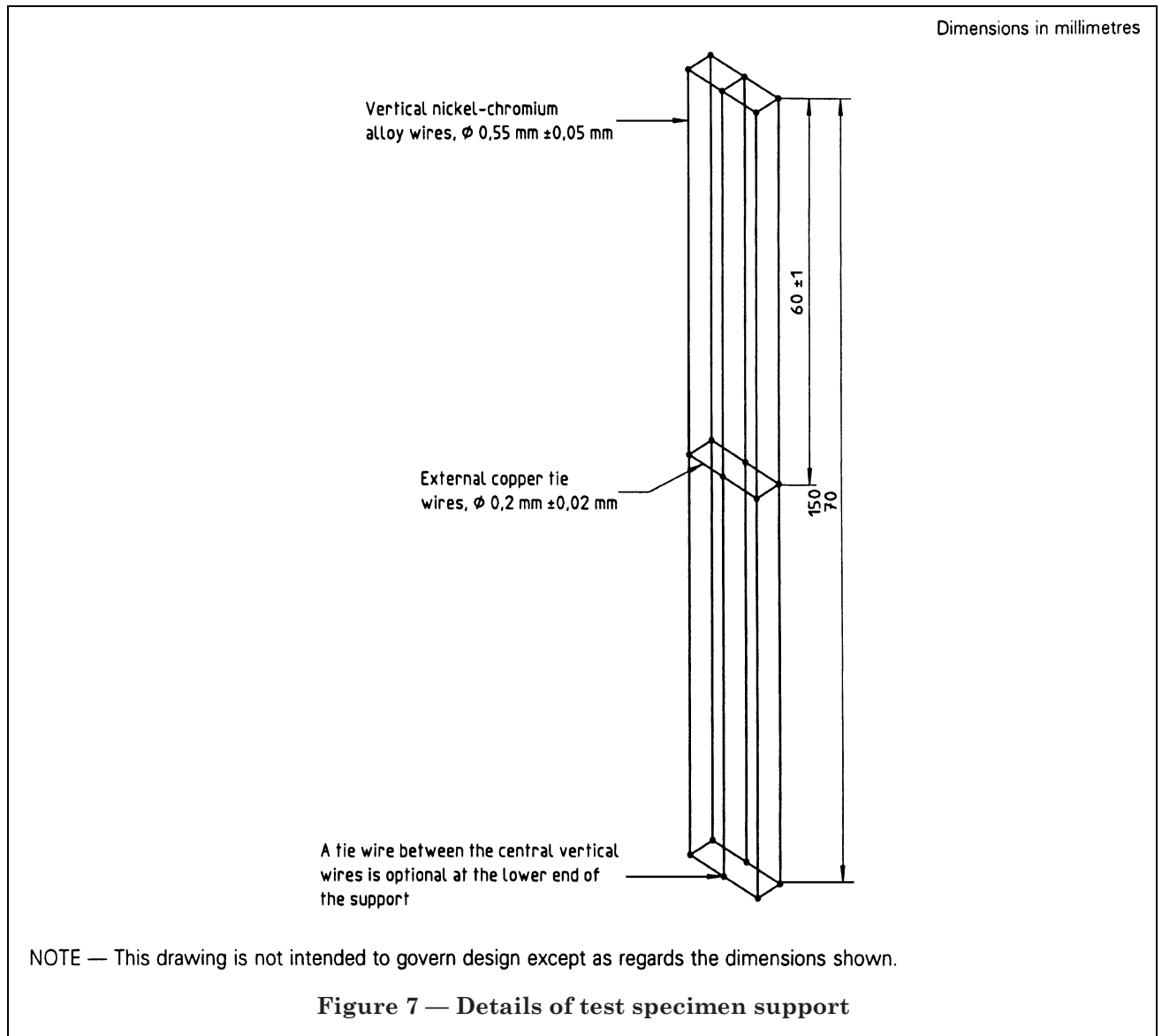

Figure 6 — Diagram of typical specimen-holder transfer tool



Annex A (normative) Measurement of flammability temperature (FT)

A.1 Maintain the room or enclosure used for the test at ambient conditions of $23\text{ °C} \pm 2\text{ °C}$ and $(50 \pm 5)\%$ r.h., unless each test specimen is conditioned in accordance with 7.4 until immediately prior to use, in which case ambient humidity control to $(50 \pm 5)\%$ r.h. is optional.

A.2 Set the flow controls so that air is flowing through the chimney at a velocity of $40\text{ mm/s} \pm 0,8\text{ mm/s}$ when measured at $23\text{ °C} \pm 2\text{ °C}$ (see 8.1.5). Carry out the remainder of the test procedure using this setting.

NOTE 7 The gas velocity or flow rate F at $23\text{ °C} \pm 2\text{ °C}$ may be estimated, in millimetres per second, from the following equation:

$$F = 1,27 \left(\frac{q_v}{d^2} \right) \times 10^6$$

where

- q_v is the total gas flow rate through the chimney, in litres per second;
- d is the internal diameter of the chimney, in millimetres.

A.3 Allow the gas mixture to flow for at least 30 s to purge the system.

A.4 Set the column temperature at a desired value using the column and preheater controls (see note 8). Using the thermocouple, adjust the controls to obtain a temperature gradient of less than 5 °C between the position of the top of the test specimen and 50 mm below this position. Resite the thermocouple 25 mm below the top of the test specimen. Allow the temperature to stabilize.

NOTE 8 The adjustment of these independent controls should be such that the preheater raises the incoming air temperature at the base of the column to approximately that of the column itself. The use of widely differing settings between preheater and column temperatures can contribute to variation in the FT value obtained.

NOTE 9 It may be helpful to perform preliminary tests during which the temperature is varied to establish an approximate value for the FT. Results of such tests should not be included in the estimation of the FT.

A.5 Using a test specimen holder preheated to the column temperature, insert a test specimen in the test specimen holder and place this in the chimney using the transfer tool. With the thermocouple positioned so that it is immediately adjacent to, but not touching, the test specimen, as shown in Figure 1, leave the apparatus for $240\text{ s} \pm 10\text{ s}$ to permit temperature stabilization, and then record the indicated air temperature.

A.6 If the recorded air temperature after stabilization is greater than 10 °C different from the temperature set in A.4, repeat the procedures of A.4 and A.5 (see notes 10 and 11). If otherwise, move the thermocouple away from the specimen and proceed immediately in accordance with A.7.

NOTE 10 It may be helpful also to preheat the transfer tool if an excessive temperature difference is induced by a chilling effect from that tool.

NOTE 11 Use of periods other than $240\text{ s} \pm 10\text{ s}$ between introduction of the test specimen and the initial application of the igniter in accordance with A.7 may lead to non-comparable results when testing materials for which the FT is sensitive to the period of exposure to elevated temperature.

A.7 Apply the ignition source so that approximately 6 mm of the flame impinges on the top of the test specimen. As the test specimen burns, lower the ignition source to maintain the flame impingement of approximately 6 mm. Apply the flame for $15\text{ s} \pm 1\text{ s}$ to ignite the test specimen. Upon removal of the ignition flame, start the timer.

A.8 Do not adjust any of the controls after ignition of the test specimen.

A.9 Observe the burning behaviour of the test specimen. Record whether the flame is extinguished before either of the relevant criteria from Table 3 of ISO 4589-2 is satisfied, i.e. the minimum period of burning is exceeded or the minimum length of the test specimen is burnt. Alternatively, when either of the criteria is exceeded, snuff out the flame and record the response of the test specimen.

A.10 Remove the used test specimen and any debris.

A.11 Depending upon the behaviour of preceding test specimens, select the temperature for the following burn. Reduce the temperature if the burning of the test specimen exceeded either the period or the length specified (see Table 3 of ISO 4589-2) or increase the temperature if neither criterion was exceeded.

A.12 Continue repeating the procedure from A.3 to A.11 inclusive until the FT is established, to within an increment of 5 °C , as the lowest column temperature, as recorded in A.5, at which the test specimen exceeds at least one of the test criteria.

NOTE 12 Increments of $>5\text{ °C}$ may be used to establish an approximate value of FT.

A.13 Determine at least three values for the FT of the material by carrying out the procedure from A.3 to A.12 inclusive at least three times.

A.14 Calculate and record the FT of the material as the mean value of the three or more values determined in accordance with A.13. Express it as the mean value when rounded to the nearest 1 °C , with an exactly intermediate result being rounded downwards.

Annex B (informative) Interlaboratory test data on flammability temperature

B.1 A round-robin correlation exercise was conducted in the UK in 1986 to assess the effect of different types of specimen support.

B.2 Eight laboratories participated in this exercise, using thermoplastic and cross-linked plastic specimens. Two specimen support holders were evaluated: one using silica rods and the other constructed of nichrome wire. A summary of the FT results are shown in Table B.1.

B.3 The type of specimen support was not found to affect the results significantly. Although silica rods had been in use by some laboratories for some time without problems, most laboratories reported difficulties with this type of support and expressed a preference for a nichrome wire support.

Table B.1 — Summary of round-robin results

All values in degrees Celsius

Specimen support	Test laboratory								FT
	1	2	3	4	5	6	7	8	Average
Thermoplastic material									
Silica rods	268	266	260	270	244	253	253	249	258
Nichrome wire	263	276	260	260	239	260	253	248	257
Cross-linked material									
Silica rods	296	274	280	270	—	273	273	280	278
Nichrome wire	292	262	280	270	272	275	267	260	272

Annex C (informative)
Typical test results sheet

Test results sheet for oxygen index at elevated temperature, determined in accordance with ISO 4589-3

Material: Oxygen index [concentration, % (V/V)]:
 Specimen form: [rounded to 0,1 % (V/V)]
 Ignition procedure: A B $\hat{\sigma}$:
 Conditioning procedure: 23 23/50 Date of test:
 Oxygen concentration increment (*d*): 0,2 % (V/V) Laboratory No.: Test No.:
 Temperature of gas mixture (°C):

Section 1: Determination of oxygen concentration for one pair of “X” and “O” responses at ≤ 1 % (V/V) O₂ concentration interval (in accordance with 8.5)

Oxygen concentration, % (V/V)									
Burning period, s									
Length burnt, mm									
Response (“X” or “O”)									

Oxygen concentration of the “O” response for the pair = % (V/V)
 (this is the concentration to be used again for the first measurement in section 2 of this annex)

Section 2: Determination of the oxygen index (in accordance with 8.6)

Step size to be used for successive changes *d* in oxygen concentration = % (V/V)
 [initially to be 0,2 % (V/V), unless otherwise instructed]

N _T series measurements										
N _L series measurements (8.6.1 and 8.6.2 of ISO 4589-2)						(8.6.3 of ISO 4589-2)				c _f
Oxygen concentration, % (V/V)										
Burning period, s										
Length burnt, mm										
Response (“X” or “O”)										
Column (2, 3, 4 or 5):						Row (1 to 16):				
k value from Table C.1:						Hence k =				

$OI = c_f + kd =$
 $=$ % (to one decimal place, for reporting OI)
 $=$ % (to two decimal places, for calculation of and verification of *d* as required in section 3)

Table C.1 — Values of k for calculating the oxygen index concentration from determinations made by Dixon's "up-and-down method"

1	2	3	4	5	6
Responses for the last five measurements	Values of k for which the first N_L determinations are				
	a) 0	00	000	0000	
X0000	-0,55	-0,55	-0,55	-0,55	OXXXX
X000X	-1,25	-1,25	-1,25	-1,25	OXXXO
X00X0	0,37	0,38	0,38	0,38	OXXOX
X00XX	-0,17	-0,14	-0,14	-0,14	OXXOO
XOX00	0,02	0,04	0,04	0,04	OXOXX
XOXOX	-0,50	-0,46	-0,45	-0,45	OXOXO
XOXXO	1,17	1,24	1,25	1,25	OXOOX
XOXXX	0,61	0,73	0,76	0,76	OXOOO
XX000	-0,30	-0,27	-0,26	-0,26	OOXXX
XX00X	-0,83	-0,76	-0,75	-0,75	OOXXO
XXOXO	0,83	0,94	0,95	0,95	OOXOX
XXOXX	0,30	0,46	0,50	0,50	OOXOO
XXX00	0,50	0,65	0,68	0,68	OOOXX
XXXOX	-0,04	0,19	0,24	0,25	OOOXO
XXXXO	1,60	1,92	2,00	2,01	OOOOX
XXXXX	0,89	1,33	1,47	1,50	OOOOO
	Values of k for which the first N_L determinations are b) X XX XXX XXXX are as given in the above table opposite the appropriate response in column 6, but with the sign of k reversed, i.e. $OI = c_f - kd$ (see 9.1 of ISO 4589-2).				Responses for the last five measurements

Section 3: Verification of step size d % oxygen concentration
(in accordance with 8.6.4 and 9.3 of ISO 4589-2)

Last six results	Oxygen concentration, % (V/V)			
	c_i^a	OI	$c_i - \text{OI}$	$(c_i - \text{OI})^2$
c_f	1			
	2			
	3			
	4			
	5			
n	6			
Total $\Sigma(c_i - \text{OI})^2$				

^a Column c_i contains the oxygen concentrations used for the measurements of c_f and for each of the 5 preceding measurements, for $n = 6$.

Estimation of standard deviation

$$\hat{\sigma} = \left[\frac{\Sigma(c_i - \text{OI})^2}{n - 1} \right]^{1/2} =$$

$$\frac{2\hat{\sigma}}{3} =$$

$$d =$$

$$\frac{3\hat{\sigma}}{2} =$$

If $\frac{2\hat{\sigma}}{3} < d < \frac{3\hat{\sigma}}{2}$ or if $0, 2 = d > \frac{3\hat{\sigma}}{2}$, OI is valid.

Otherwise

if $\frac{2\hat{\sigma}}{3} > d$, repeat section 2 using a larger value for d ;

or

if $\frac{3\hat{\sigma}}{2} < d$, repeat section 2 using a smaller value for d .

Then again verify the step size, making further changes to the step size if necessary until one of the verification relationships is satisfied.

Section 4: Ancillary information

- a) These test results relate only to the behaviour of the specimens under the conditions of this test. These results must not be used to infer the relative hazards presented by differing materials or shapes under these or other fire conditions.
- b) Special material history/characteristics, if applicable:
- c) Variations from standard procedure, if applicable:
- d) Description of observed burning behaviour:
- e) Results measured/reported by:

BSI — British Standards Institution

BSI is the independent national body responsible for preparing British Standards. It presents the UK view on standards in Europe and at the international level. It is incorporated by Royal Charter.

Revisions

British Standards are updated by amendment or revision. Users of British Standards should make sure that they possess the latest amendments or editions.

It is the constant aim of BSI to improve the quality of our products and services. We would be grateful if anyone finding an inaccuracy or ambiguity while using this British Standard would inform the Secretary of the technical committee responsible, the identity of which can be found on the inside front cover. Tel: 020 8996 9000. Fax: 020 8996 7400.

BSI offers members an individual updating service called PLUS which ensures that subscribers automatically receive the latest editions of standards.

Buying standards

Orders for all BSI, international and foreign standards publications should be addressed to Customer Services. Tel: 020 8996 9001. Fax: 020 8996 7001.

In response to orders for international standards, it is BSI policy to supply the BSI implementation of those that have been published as British Standards, unless otherwise requested.

Information on standards

BSI provides a wide range of information on national, European and international standards through its Library and its Technical Help to Exporters Service. Various BSI electronic information services are also available which give details on all its products and services. Contact the Information Centre. Tel: 020 8996 7111. Fax: 020 8996 7048.

Subscribing members of BSI are kept up to date with standards developments and receive substantial discounts on the purchase price of standards. For details of these and other benefits contact Membership Administration. Tel: 020 8996 7002. Fax: 020 8996 7001.

Copyright

Copyright subsists in all BSI publications. BSI also holds the copyright, in the UK, of the publications of the international standardization bodies. Except as permitted under the Copyright, Designs and Patents Act 1988 no extract may be reproduced, stored in a retrieval system or transmitted in any form or by any means – electronic, photocopying, recording or otherwise – without prior written permission from BSI.

This does not preclude the free use, in the course of implementing the standard, of necessary details such as symbols, and size, type or grade designations. If these details are to be used for any other purpose than implementation then the prior written permission of BSI must be obtained.

If permission is granted, the terms may include royalty payments or a licensing agreement. Details and advice can be obtained from the Copyright Manager. Tel: 020 8996 7070.