

BS EN ISO 4254-11:2010



BSI Standards Publication

# Agricultural machinery — Safety

Part 11: Pick-up balers (ISO 4254-11:2010)

**bsi.**

...making excellence a habit.™

**National foreword**

This British Standard is the UK implementation of EN ISO 4254-11:2010. It supersedes BS EN 704:1999+A1:2009 which is withdrawn.

The UK participation in its preparation was entrusted to Technical Committee AGE/32, Agricultural implements and trailers.

A list of organizations represented on this committee can be obtained on request to its secretary.

This publication does not purport to include all the necessary provisions of a contract. Users are responsible for its correct application.

© BSI 2011

ISBN 978 0 580 57062 9

ICS 65.060.50

**Compliance with a British Standard cannot confer immunity from legal obligations.**

This British Standard was published under the authority of the Standards Policy and Strategy Committee on 31 January 2011.

**Amendments issued since publication**

Date	Text affected
------	---------------

---

English Version

**Agricultural machinery - Safety - Part 11: Pick-up balers  
(ISO 4254-11:2010)**

Matériel agricole - Sécurité - Partie 11: Ramasseuses-  
presses (ISO 4254-11:2010)

Landmaschinen - Sicherheit - Teil 11: Sammelpressen ISO  
4254-11:2010

This European Standard was approved by CEN on 14 December 2010.

CEN members are bound to comply with the CEN/CENELEC Internal Regulations which stipulate the conditions for giving this European Standard the status of a national standard without any alteration. Up-to-date lists and bibliographical references concerning such national standards may be obtained on application to the CEN-CENELEC Management Centre or to any CEN member.

This European Standard exists in three official versions (English, French, German). A version in any other language made by translation under the responsibility of a CEN member into its own language and notified to the CEN-CENELEC Management Centre has the same status as the official versions.

CEN members are the national standards bodies of Austria, Belgium, Bulgaria, Croatia, Cyprus, Czech Republic, Denmark, Estonia, Finland, France, Germany, Greece, Hungary, Iceland, Ireland, Italy, Latvia, Lithuania, Luxembourg, Malta, Netherlands, Norway, Poland, Portugal, Romania, Slovakia, Slovenia, Spain, Sweden, Switzerland and United Kingdom.



EUROPEAN COMMITTEE FOR STANDARDIZATION  
COMITÉ EUROPÉEN DE NORMALISATION  
EUROPÄISCHES KOMITEE FÜR NORMUNG

**Management Centre: Avenue Marnix 17, B-1000 Brussels**

## Foreword

This document (EN ISO 4254-11:2010) has been prepared by Technical Committee ISO/TC 23 “Tractors and machinery for agriculture and forestry” in collaboration with Technical Committee CEN/TC 144 “Tractors and machinery for agriculture and forestry” the secretariat of which is held by AFNOR.

This European Standard shall be given the status of a national standard, either by publication of an identical text or by endorsement, at the latest by June 2011, and conflicting national standards shall be withdrawn at the latest by June 2011.

Attention is drawn to the possibility that some of the elements of this document may be the subject of patent rights. CEN [and/or CENELEC] shall not be held responsible for identifying any or all such patent rights.

This document supersedes EN 704:1999+A1:2009.

This document has been prepared under a mandate given to CEN by the European Commission and the European Free Trade Association, and supports essential requirements of the Machinery Directive 2006/42/EC. It is intended to be used together with EN ISO 4254-1:2009, *Agricultural machinery — Safety — Part 1: General requirements (ISO 4254-1:2008)*, and EN 15811:2009, *Agricultural machinery — Guards for moving parts of power transmission — Guard opening with tool (ISO/TS 28923:2007 modified)*.

For relationship with EU Directive, see informative Annex ZA, which is an integral part of this document.

The following major changes were introduced:

- deletion of the reference to prEN 1553:1998, *Agricultural machinery — Agricultural self-propelled, mounted, semi-mounted and trailed machines — Common safety requirements*, and replacement with EN ISO 4254-1:2009, *Agricultural machinery — Safety — Part 1: General requirements (ISO 4254-1:2008)*;
- deletion of the requirements related to the guarding of moving parts for power transmission dealt with in EN 15811:2009, *Agricultural machinery — Guards for moving parts of power transmission — Guard opening with tool (ISO/TS 28923:2007 modified)*;
- inclusion in the Scope of combination of pick-up balers with wrappers (and new requirements from 5.2.7 to 5.2.7.2.4);
- new requirements for feeding elements designed as augers (5.2.3.1, second sentence, and new 5.2.3.2);
- new requirements on automatic starting systems (5.2.4);
- new requirements on manual feeding of twine (5.2.5);
- new requirements on changing of knives (5.2.6);
- modification on requirements against hazards related to clearing blockages (5.4.1.1 and 5.4.1.2);
- new requirements on bale ejection door (5.4.2.1 second sentence and 5.4.2.2).

According to the CEN/CENELEC Internal Regulations, the national standards organizations of the following countries are bound to implement this European Standard: Austria, Belgium, Bulgaria, Croatia, Cyprus, Czech Republic, Denmark, Estonia, Finland, France, Germany, Greece, Hungary, Iceland, Ireland, Italy, Latvia,

Lithuania, Luxembourg, Malta, Netherlands, Norway, Poland, Portugal, Romania, Slovakia, Slovenia, Spain, Sweden, Switzerland and the United Kingdom.

**Endorsement notice**

The text of ISO 4254-11:2010 has been approved by CEN as a EN ISO 4254-11:2010 without any modification.

## Annex ZA (informative)

### Relationship between this European Standard and the Essential Requirements of EU Directive 2006/42/EC

This European Standard has been prepared under a mandate given to CEN by the European Commission and the European Free Trade Association to provide a means of conforming to Essential Requirements of the New Approach Directive 2006/42/EC on machinery.

Once this standard is cited in the Official Journal of the European Union under that Directive and has been implemented as a national standard in at least one Member State, compliance with the normative clauses of this standard confers, within the limits of the scope of this standard, a presumption of conformity with the relevant Essential Requirements, except *Essential Requirements 1.1.4, 1.1.7, 1.1.8 (self-propelled machines only), 1.2.1, 1.2.4, 1.2.6, 1.3.2, 1.3.8.1, 1.4.2.1 (2nd paragraph), 1.5.5 (self-propelled machines only), 1.5.8, 1.5.9, 1.7.4.2 u), 3.3.2, 3.3.3, 3.4.3 and 3.6.3.1* of that Directive and associated EFTA regulations.

**WARNING — Other requirements and other EU Directives may be applicable to the product(s) falling within the scope of this standard.**

## Contents

Page

Foreword .....	iv
Introduction.....	v
1 Scope .....	1
2 Normative references.....	1
3 Terms and definitions .....	2
4 List of significant hazards .....	2
5 Safety requirements and/or protective measures.....	4
5.1 General .....	4
5.2 Requirements for all types of balers .....	4
5.3 Requirements for rectangular balers .....	8
5.4 Requirements for round balers.....	12
6 Verification of the safety requirements and/or protective measures .....	13
7 Information for use .....	13
7.1 Operator's manual .....	13
7.2 Marking.....	14
Bibliography.....	15

## Foreword

ISO (the International Organization for Standardization) is a worldwide federation of national standards bodies (ISO member bodies). The work of preparing International Standards is normally carried out through ISO technical committees. Each member body interested in a subject for which a technical committee has been established has the right to be represented on that committee. International organizations, governmental and non-governmental, in liaison with ISO, also take part in the work. ISO collaborates closely with the International Electrotechnical Commission (IEC) on all matters of electrotechnical standardization.

International Standards are drafted in accordance with the rules given in the ISO/IEC Directives, Part 2.

The main task of technical committees is to prepare International Standards. Draft International Standards adopted by the technical committees are circulated to the member bodies for voting. Publication as an International Standard requires approval by at least 75 % of the member bodies casting a vote.

Attention is drawn to the possibility that some of the elements of this document may be the subject of patent rights. ISO shall not be held responsible for identifying any or all such patent rights.

ISO 4254-11 was prepared by Technical Committee ISO/TC 23, *Tractors and machinery for agriculture and forestry*, Subcommittee SC 7, *Equipment for harvesting and conservation*.

For the purposes of global relevance, the requirements related to the guarding of moving parts for power transmission have been transferred and published as two separate Technical Specifications: ISO/TS 28923:2007 (Guard opening with tool) and ISO/TS 28924:2007, which include the requirements taken from both 4.6 and Annex C of ISO 4254-1:2008.

ISO 4254 consists of the following parts, under the general title *Agricultural machinery — Safety*:

- *Part 1: General requirements*
- *Part 5: Power-driven soil-working machines*
- *Part 6: Sprayers and liquid fertilizer distributors*
- *Part 7: Combine harvesters, forage harvesters and cotton harvesters*
- *Part 8: Solid fertilizer distributors*
- *Part 9: Seed drills*
- *Part 10: Rotary tedders and rakes*
- *Part 11: Pick-up balers*
- *Part 12: Rotary disc and drum mowers and flail mowers*
- *Part 13: Large rotary mowers<sup>1)</sup>*

Part 2, *Anhydrous ammonia applicators*, has been withdrawn; Part 3, *Tractors*, has been cancelled and is to be replaced by ISO 26322 (all parts), *Tractors for agriculture and forestry — Safety*; and Part 4, *Forestry winches*, has been cancelled and replaced by ISO 19472, *Machinery for forestry — Winches — Dimensions, performance and safety*.

---

1) Under preparation.



## Introduction

The structure of safety standards in the field of machinery is as follows:

- a) type-A standards (basic standards) giving basic concepts, principles for design, and general aspects that can be applied to machinery;
- b) type-B standards (generic safety standards) dealing with one or more safety aspects or one or more types of safeguards that can be used across a wide range of machinery:
  - type-B1 standards on particular safety aspects (e.g. safety distances, surface temperature, noise);
  - type-B2 standards on safeguards (e.g. two-hand controls, interlocking devices, pressure-sensitive devices, guards);
- c) Type-C standards (machinery safety standards) dealing with detailed safety requirements for a particular machine or group of machines.

This document is a type-C standard as stated in ISO 12100.

The machinery concerned and the extent to which hazards, hazardous situations or hazardous events are covered are indicated in the Scope of this part of ISO 4254. These hazards are specific to self-propelled and trailed pick-up balers, including the combination of pick-up balers with wrappers.

Significant hazards that are common to all the agricultural machines (self-propelled ride-on, mounted, semi-mounted and trailed) are dealt with in ISO 4254-1.

When requirements of this type-C standard are different from those which are stated in type-A or type-B standards, the requirements of this type-C standard take precedence over the requirements of the other standards for machines that have been designed and built according to the provisions of this type-C standard.



# Agricultural machinery — Safety —

## Part 11: Pick-up balers

### 1 Scope

This part of ISO 4254, intended to be used together with ISO 4254-1, specifies the safety requirements and their verification for the design and construction of self-propelled and trailed pick-up balers, including the combination of pick-up balers with wrappers, independent of the shape or size of the bales formed. It describes methods for the elimination or reduction of hazards arising from the intended use and reasonably foreseeable misuse of these machines by one person (the operator) in the course of normal operation and service. In addition, it specifies the type of information on safe working practices to be provided by the manufacturer.

When requirements of this part of ISO 4254 are different from those which are stated in ISO 4254-1, the requirements of this part of ISO 4254 take precedence over the requirements of ISO 4254-1 for machines that have been designed and built according to the requirements of this part of ISO 4254.

This part of ISO 4254, taken together with ISO 4254-1, deals with all the significant hazards (as listed in Table 1), hazardous situations and events relevant to self-propelled and trailed pick-up balers, including the combination of pick-up balers with wrappers, when they are used as intended and under the conditions of misuse that are reasonably foreseeable by the manufacturer (see Clause 4).

This part of ISO 4254 is not applicable to pedestrian-controlled round balers, environmental hazards, road safety, vibration and hazards related to moving parts for power transmission. It is not applicable to hazards related to maintenance or repairs carried out by professional service personnel.

NOTE Specific requirements related to road traffic regulations are not taken into account in this part of ISO 4254.

This part of ISO 4254 is not applicable to machines manufactured before the date of its publication.

### 2 Normative references

The following referenced documents are indispensable for the application of this document. For dated references, only the edition cited applies. For undated references, the latest edition of the referenced document (including any amendments) applies.

ISO 3600:1996, *Tractors, machinery for agriculture and forestry, powered lawn and garden equipment — Operator's manuals — Content and presentation*

ISO 4254-1:2008, *Agricultural machinery — Safety — Part 1: General requirements*

ISO 11684:1995, *Tractors, machinery for agricultural and forestry, powered lawn and garden equipment — Safety signs and hazard pictorials — General principles*

ISO 12100:—, *Safety of machinery — General principles for design — Risk assessment and risk reduction*<sup>2)</sup>

---

2) To be published.

ISO 13857:2008, *Safety of machinery — Safety distances to prevent hazard zones being reached by upper and lower limbs*

ISO 14982:1998, *Agricultural and forestry machinery — Electromagnetic compatibility — Test methods and acceptance criteria*

### 3 Terms and definitions

For the purposes of this document, the terms and definitions given in ISO 12100 and ISO 4254-1 apply.

### 4 List of significant hazards

Table 1 specifies the significant hazards, the significant hazardous situations and significant hazardous events that have been identified by risk assessment as being significant for this type of machine, covered by this part of ISO 4254, and which may require specific action by the designer or manufacturer to eliminate or reduce the risk.

Attention is drawn to the necessity to verify that the safety requirements specified in this part of ISO 4254 apply to each significant hazard presented by a given machine and to validate that the risk assessment is complete.

**Table 1 — List of significant hazards associated with self-propelled and trailed pick-up balers, including the combination of pick-up balers with wrappers**

No. <sup>a</sup>	Hazard	Hazardous situation and event	Clause/subclause of ISO 4254-1:2008	Clause/subclause of this part of ISO 4254
<b>A.1 Mechanical hazards</b>				
A.1.1	Crushing	Manual feeding; uncontrolled movements of the drawbar; contact with pick-up device; contact with feeding elements; contact with the flywheel or other moving parts, ejection of the bale	4.7; 4.8; 4.14.1; 4.14.3; 4.14.5; 4.14.6; 5.2; 6.4	5.1; 5.2; 5.3; 5.4; 7.1; 7.2
A.1.2	Shearing	Manual feeding; uncontrolled movements of the drawbar; contact with pick-up device; contact with feeding elements; contact with the flywheel, knotting mechanism or other moving parts	4.7; 4.8; 4.14.1; 4.14.3; 4.14.5; 4.14.6; 5.2; 6.4	5.1; 5.2; 5.3; 5.4; 7.1; 7.2
A.1.3	Cutting or severing	Manual feeding; contact with pick-up device; contact with feeding elements; contact with the flywheel, knotting mechanism or other moving parts	4.7	5.1; 5.2; 5.3; 5.4; 7.1; 7.2
A.1.4	Entanglement	Manual feeding; contact with pick-up device; contact with feeding elements; contact with the flywheel, knotting mechanism or other moving parts	6.4; 4.7	5.1; 5.2; 5.3; 5.4; 7.1; 7.2
A.1.5	Drawing-in or trapping	Manual feeding; contact with pick-up device; contact with feeding elements; contact with the flywheel, knotting mechanism or other moving parts	6.4; 4.7	5.1; 5.2; 5.3; 5.4; 7.1; 7.2
A.1.6	Impact	Manual feeding; uncontrolled movements of the drawbar; contact with pick-up device; contact with feeding elements; contact with the flywheel, knotting mechanism or other moving parts	4.14.5; 4.14.6; 5.1.3.1	5.1; 5.2; 5.3; 5.4; 7.1; 7.2

Table 1 (continued)

No. <sup>a</sup>	Hazard	Hazardous situation and event	Clause/subclause of ISO 4254-1:2008	Clause/subclause of this part of ISO 4254
A.1.7	Stabbing or puncture	Manual feeding; contact with pick-up device; contact with feeding elements; contact with the flywheel, knotting mechanism or other moving parts	4.7	5.1; 5.3.4; 7.1; 7.2
A.1.8	Friction or abrasion	Manual feeding; contact with pick-up device; contact with feeding elements; contact with the flywheel, knotting mechanism or other moving parts	4.4.3; 5.1.3.2; 4.9.1; 4.5.1.1.2	5.1; 5.3.1; 7.1; 7.2
A.1.9	High-pressure fluid injection	Ejection due to excessive pressure in the hoses	4.10; 6.5	7.1
A.1.10	Ejection of parts	Ejection of the bales	—	5.3.6; 5.4.2
<b>A.5 Hazards generated by materials and substances</b>				
A.5.2	Fire or explosion		4.12; 5.1.6; 5.5	7.1
<b>A.6 Hazards generated by neglecting ergonomic principles in machinery design</b>				
A.6.6	Human error, human behaviour		4.4; 8.1; 8.2	7.1; 7.2.3
A.6.7	Inadequate design, location or identification manual controls		4.4; 5.1.3; 6.1; 8.1; 8.2	5.2.4.2; 5.2.7.1; 5.3.4.6; 5.4.1.2; 6; 7.2.3.3
<b>A.7 Combination of hazards</b>				
A.7.1	Manual operation of individual assemblies;  Missing or insufficient information about manual operation of individual assemblies and, if required, use of special tools in the operator's manual		8.1.3	7.1  7.2
A.7.2	Safety signs and signals		8.2	7.2.3
A.7.3	Essential equipment and accessories for safe adjusting and/or maintaining		4.8; 4.14; 8.1.3	7.1; 7.2
<b>A.8 Unexpected start-up, unexpected overrun/overspeed</b>				
A.8.1	Failure/disorder of the control system		4.8.2; 5.1.8; 6.1.1	5.2.7.1; 5.2.7.2; 5.3.1; 5.3.3; 5.3.4.6
<b>A.11</b>	<b>Failure of power supply</b>	Starting and stopping devices	4.8.2; 5.1.8; 6.1.1	5.2.4; 5.4.1; 5.4.2
<b>A.13</b>	<b>Errors of fitting</b>		6.2; 6.3; 8.1; 8.2	7.1; 7.2

Table 1 (continued)

No. <sup>a</sup>	Hazard	Hazardous situation and event	Clause/subclause of ISO 4254-1:2008	Clause/subclause of this part of ISO 4254
A.14	Guards and barriers		4.7	7.1
	Supports		4.8	7.2
<b>A.21</b>	<b>Lack of stability</b>		6.2; 8.1.3	7.1.4
<b>A.22 Due to the power source and to the transmission of power</b>				
A.22.3	Hazards from coupling and towing		6.3; 8.1.3	—
<sup>a</sup> With reference to ISO 4254-1:2008, Table A.1.				

## 5 Safety requirements and/or protective measures

### 5.1 General

**5.1.1** Machinery shall comply with the safety requirements and/or protective measures of this clause. In addition, the machine shall be designed in accordance with the principles of ISO 12100:—, Clause 4, for hazards relevant, but not significant, which are not dealt with by this part of ISO 4254.

**5.1.2** Except where otherwise specified in this part of ISO 4254, the machine shall comply with the requirements of ISO 4254-1 and with Tables 1, 3, 4 and 6 of ISO 13857:2008 as appropriate.

**5.1.3** Machinery shall comply with ISO 14982 for evaluating the electromagnetic compatibility.

### 5.2 Requirements for all types of balers

#### 5.2.1 Drawbar

When the drawbar has separate positions, for transport and for working, it shall be provided with a mechanical or hydraulic locking device that requires an intentional action to change from transport to working position and from working to transport position (e.g. pin, latch or hydraulic cylinder). When a hydraulic device is used, the drawbar shall remain locked in position if the hydraulic circuit fails or else the requirements of 4.8.3 of ISO 4254-1:2008 shall apply.

#### 5.2.2 Pick-up device

Protection against inadvertent contact with the pick-up device shall be provided by parts of the machine, guards, barriers or a combination of these. The position of parts which may be adjustable shall always remain within the limits specified in 5.2.2.1. The projection on a horizontal plane of these protective devices shall be continuous.

NOTE Requirements for the strength of barriers and guards are given in ISO 4254-1:2008, Annex C.

**5.2.2.1** When the pick-up device is in the working position as defined in the operator's manual, these barriers shall be:

- a minimum of 230 mm in front of the most forward point of the tine path and at a height,  $h$ , as low as practicable between 300 mm and 1 000 mm above the ground, as defined in Figure 1;
- a minimum of 150 mm from the sides of the tine path at a maximum height above the ground of 500 mm (see Figure 1). If the tine path is totally covered by a part of the machine when viewed from the side, as defined and shown in Figure 2, this barrier is not required.

**5.2.2.2** When the pick-up device is in the working position, side guards, if fitted, shall be located in accordance with Figure 2.

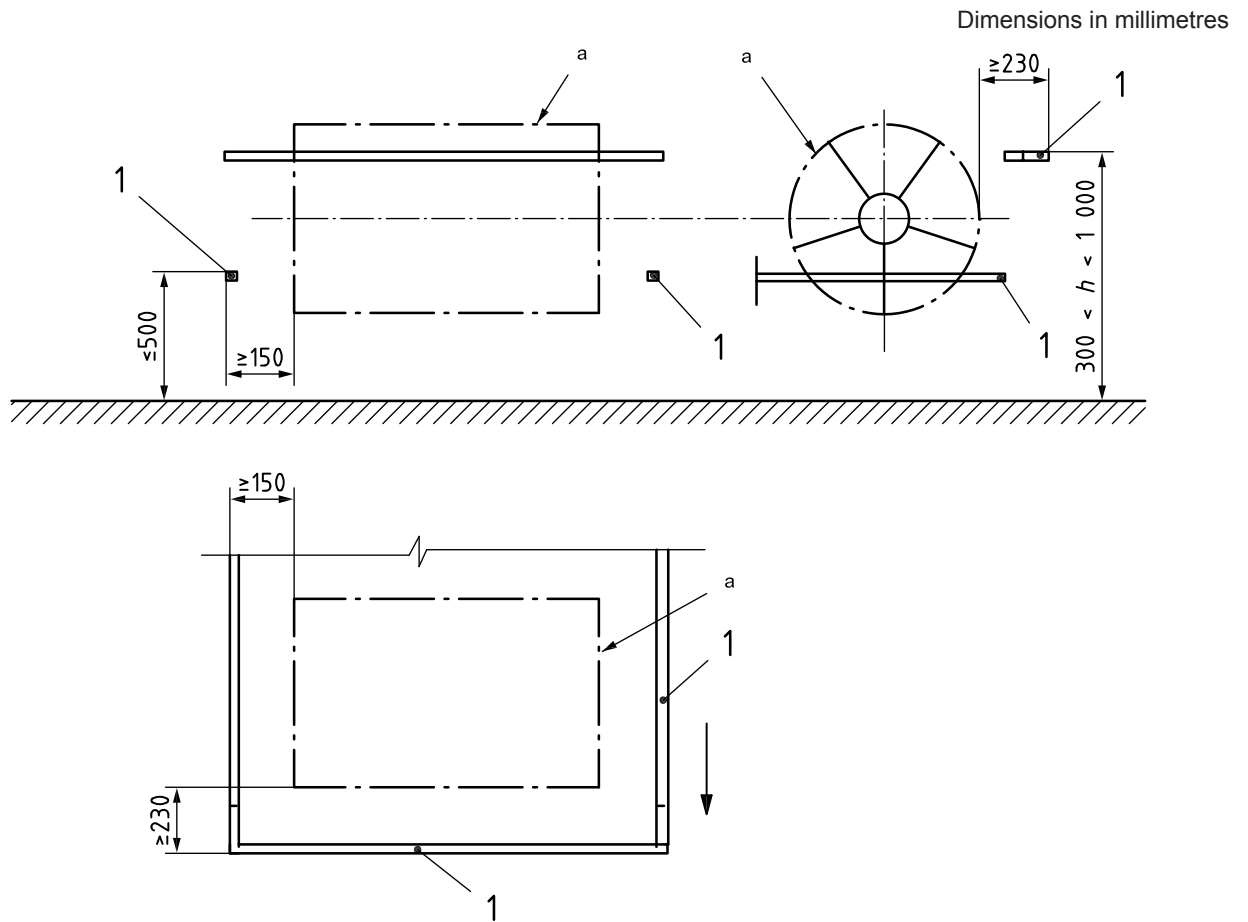

**Key**

- 1 barrier
- a Tine path.

**NOTE** This figure illustrates an example of protective devices complying with 5.2.2.

**Figure 1 — Guarding of the pick-up device definable by a combination of barriers**

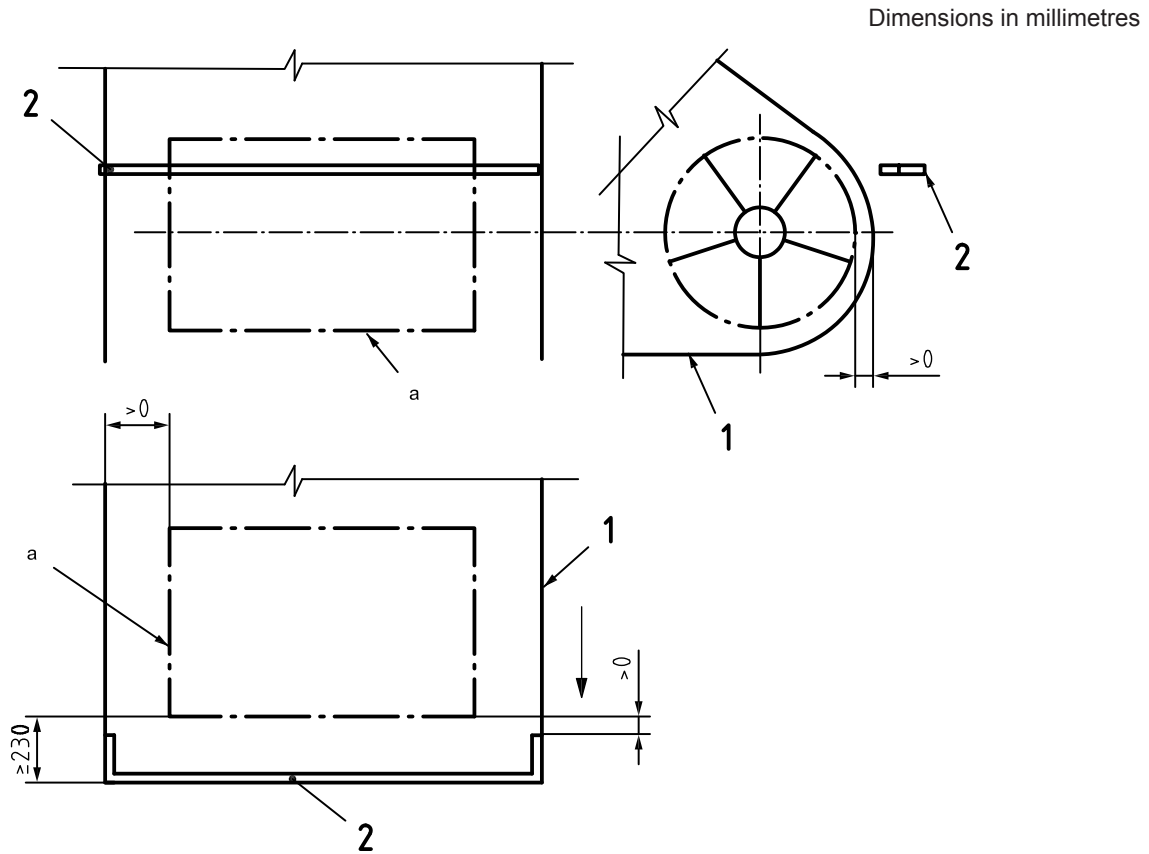

**Key**

- 1 fixed guard or part of the machine
- 2 barrier
- a Tine path.

NOTE This figure illustrates an example of protective devices complying with 5.2.2.

**Figure 2 — Guarding of the pick-up device definable by a combination of barriers and fixed guards or parts of the machine**

**5.2.3 Feeding elements**

**5.2.3.1** Crushing and shearing points located at a distance of less than 550 mm from the outer limit of the machine or from the extreme edges of the feeding channel shall be guarded against inadvertent contact and shall meet the requirements as defined in ISO 13857. In case the elements to convey the crop laterally are designed as augers, the guard above the auger shall extend forward from the rear of the auger to at least the longitudinal axis of the auger as shown in Figure 3. Devices other than augers shall be guarded on top in a comparable manner to meet the requirements as specified in ISO 13857.

**5.2.3.2** A lateral fixed guard partially covering the auger and a distance barrier, in combination with barriers as defined in 5.2.2.1, are deemed to meet the requirements of 5.2.3.1 when the dimensions of Figure 3 are respected.



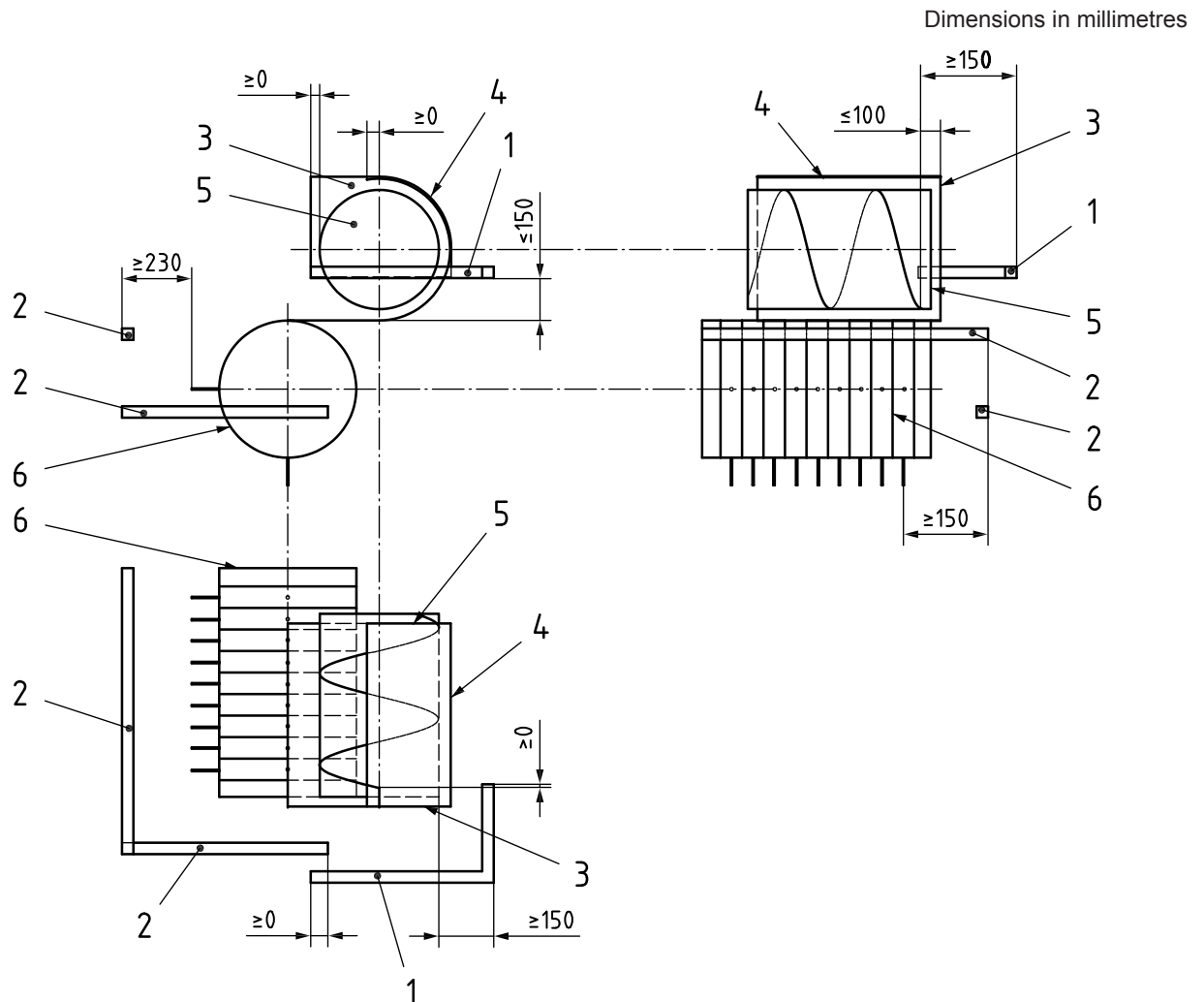

**Key**

- 1 barrier
- 2 barrier, as defined in 5.2.2.1
- 3 lateral rigid fixed guard
- 4 rear covering above the auger
- 5 feeding auger
- 6 pick-up

**Figure 3 — Guarding of the feeding elements**

**5.2.4 Automatic starting systems**

**5.2.4.1** Systems with moving components that are engaged by a triggering mechanism shall have a device in order to prevent an inadvertent start-up of these elements, e.g. knotter mechanism, tying mechanism or feeder system.

**5.2.4.2** The control of this device shall have a contrasting colour and the method of operation shall be explained on or in close proximity to this control, as well as in the operator's manual.

**5.2.5 Manual feeding of twine**

Specific instructions, stating the hazards related to the manual feeding of the twine on to the bale to start the twine-tying process as the bale is rotating, shall be given in the operator's manual [see 7.1.4 o)].

## 5.2.6 Changing of knives

Specific instructions on the procedures to be followed for the changing of knives (e.g. stop the machine and constrain the flywheel) shall be given in the operator's manual [see 7.1.4 p)].

## 5.2.7 Pick-up balers with wrappers

### 5.2.7.1 Requirements for balers with integrated wrapper

**5.2.7.1.1** For maintenance purposes and for clearance of failures, the wrapper shall be equipped with a device for isolating the energy supply. The activation of the isolating device shall only be possible outside the hazard zone.

**5.2.7.1.2** In addition, wrapping devices with rotating arms shall be equipped with a trip device. Contact with this trip device shall stop the movement of the rotating arm before the rotating arm comes into contact with the operator.

**5.2.7.1.3** Provisions shall be made to shut off the energy supply automatically when the normal cycle is not correctly performed. Following an automatic stop, the automatic cycle shall be deactivated and a restart shall be possible only after an intentional action by the operator from outside the danger zone.

### 5.2.7.2 Requirements for balers combined with wrappers

**5.2.7.2.1** The provisions of 5.2.7.1 apply.

**5.2.7.2.2** The operator's manual shall include information on whether the pick-up baler can be combined with wrappers [see 7.1.4 u)].

**5.2.7.2.3** If the pick-up baler is capable of being combined with a wrapper, it shall be equipped with an appropriate connecting device for the wrapper.

**5.2.7.2.4** For the control system, the provisions of 5.2.7.1 apply.

## 5.3 Requirements for rectangular balers

### 5.3.1 Flywheel

**5.3.1.1** Parts of the flywheel accessible from the ground or operator position shall be guarded according to provisions for moving transmission parts against inadvertent contact.

**5.3.1.2** If the flywheel guard is open underneath, a distance of at least 25 mm shall be provided between the flywheel and the guard; this 25 mm shall extend from the lower edge of the guard for a distance of at least 120 mm; the lower edge of the guard shall extend at least to the lower edge/contour of the flywheel and shall be located at a maximum distance of 800 mm from the ground (see Figure 4).

Dimensions in millimetres

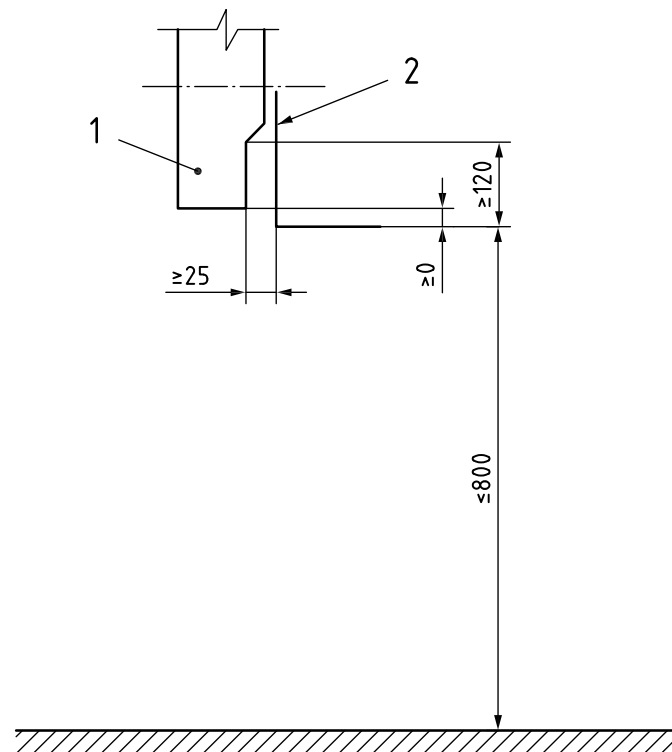

**Key**

- 1 flywheel
- 2 guard

**Figure 4 — Guarding of flywheel**

**5.3.1.3** For balers capable of forming bales with a cross-section of 0,25 m<sup>2</sup> or greater:

- it shall be possible to immobilize the flywheel to avoid unintentional movement after it has stopped for maintenance, service or failure of the process;
- when the flywheel is positioned in such a way that it is located above the crop flow when packing, the lower part of the flywheel can be exposed, providing the flywheel has a smooth surface and the upper part is guarded for at least 2/3 of the flywheel diameter measured vertically from the top.

**5.3.2 Driving mechanism for the plunger**

**5.3.2.1** The connecting rod and crank mechanism shall be guarded according to provisions for moving transmission parts against inadvertent contact. If the guard of the rod and crank mechanism is open underneath, the side guard shall cover the extreme path of the crank when viewed from the side. Furthermore, a distance of at least 25 mm shall be provided between the rod and the crank mechanism and the guard; this 25 mm clearance shall extend from the edge of the guard for a distance of at least 120 mm (see Figure 5).

**5.3.2.2** If fixed parts of the baler are located directly below the crank path at a distance, *d*, less than 300 mm from it, then the side guard shall extend below these fixed parts (see Figure 5).

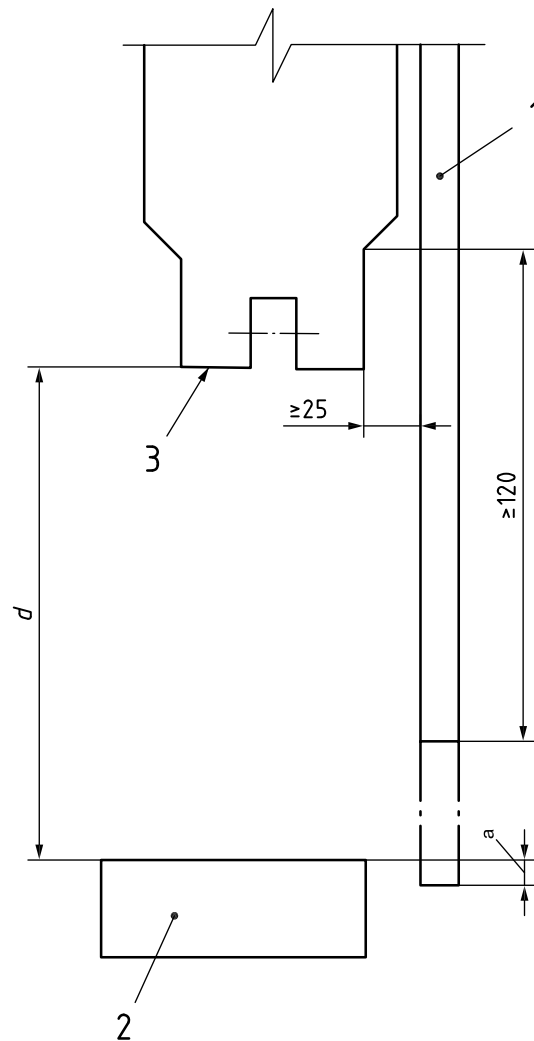

**Key**

- 1 guard
- 2 fixed part of the baler
- 3 lowest position of the crank
- a  $\geq 0$  if  $d < 300$ .

**Figure 5 — Guarding of the driving mechanism for the plunger**

**5.3.3 Transmission parts of feeding elements**

**5.3.3.1** On balers capable of forming bales with a cross-section smaller than 0,25 m<sup>2</sup>, the transmission parts of the feeding elements, located in the upper part of the machine, shall be guarded according to provisions for moving transmission parts against inadvertent contact.

**5.3.3.2** When the crushing or shearing points are located less than 850 mm from the outer limit of the machine, a guard shall be fitted in such a way that its upper edge is located at a vertical distance of at least 130 mm above the extreme path of the crank.

**5.3.3.3** Between the guard and the movable parts of the machine, there shall be a safety distance of at least 50 mm.

### 5.3.4 Knotter and tying mechanism

5.3.4.1 On the top and on the left- and right-hand sides, the knotter shall be guarded.

5.3.4.2 In the direction of travelling at the front and rear of the machine:

- when the knotter is not accessible from the ground (in accordance with Table 1 of ISO 13857:2008), no protection is required;
- when the knotter is accessible from the ground (in accordance with Table 1 of ISO 13857:2008), the front part shall be guarded in accordance with Table 4 of ISO 13857 and the rear part shall be guarded against inadvertent contact in accordance with Figure 6.

5.3.4.3 The moving parts of the tying mechanism shall be guarded according to provisions for moving transmission parts against inadvertent contact.

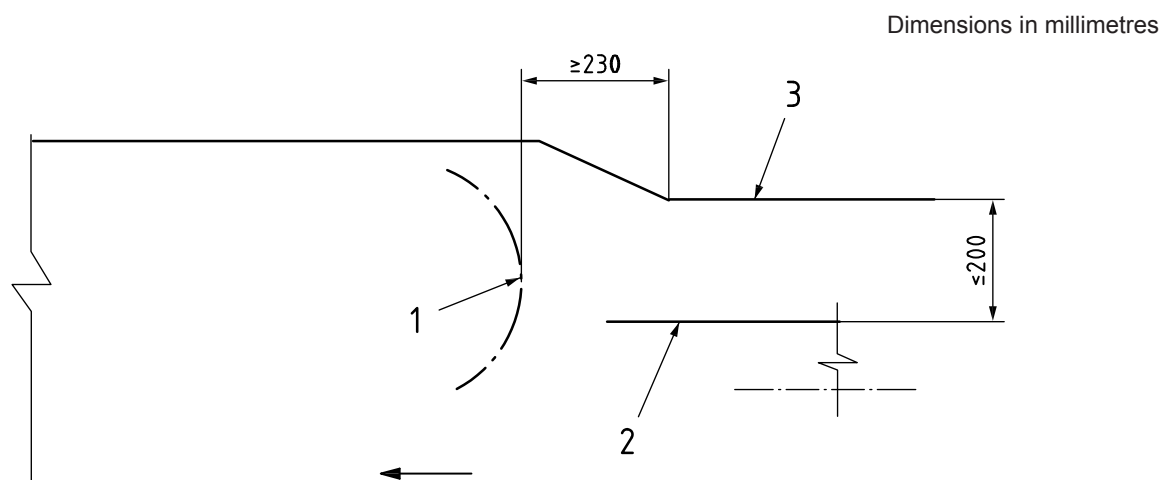

#### Key

- 1 rear outer contour of the tying mechanism
- 2 top of bale chamber
- 3 guard

**Figure 6 — Guarding of the rear part of the knotter when it is accessible from the ground**

5.3.4.4 If the distance between the wall of the channel and the end of the needle in the lower extreme position is greater than 20 mm, the end of the needle shall be guarded on both sides. The crushing and shearing points accessible on the sides in the needle movement zone shall be guarded at a minimum along the entire course of the needle movement.

5.3.4.5 If the guard is open underneath, a distance of at least 25 mm shall be provided between the guard and the moving parts of the machine. This 25 mm clearance shall extend from the edge of the guard for a distance of at least 120 mm.

5.3.4.6 When the knotting system contains a blower or blowers to keep the area free of chaff and trash, then:

- the blowers shall engage and disengage simultaneously with the tractor power take-off (PTO);
- either the blowers shall be located in a way that inadvertent contact with the wings is not possible during inspection, service and maintenance, or the blowers shall be protected by interlocking devices.

NOTE Further requirements will be added in a future revision of this part of ISO 4254 giving more precision to:

- the location of the control of the device to prevent inadvertent start-up of the knotter and tying mechanism;
- the location of spools of tying material (e.g. string, netting);
- the illumination of the tying mechanism;
- the protection by design of the crushing and shearing points on the tying mechanism;
- the hazards related to manually feeding the twine on to the bale to start the twine-tying process as the bale is rotating [7.1.4 o)].

### 5.3.5 Bale thrower

**5.3.5.1** The bale entry points shall be guarded according to provisions for moving transmission parts against crushing or shearing hazards. The bale path may remain open on the sides.

**5.3.5.2** When the thrower is a throwing fork, the fork or pallet stroke to remove the bales from the baler shall be guarded on both sides according to provisions for moving transmission parts.

### 5.3.6 Retaining device

On balers capable of forming bales with a cross-section of 0,25 m<sup>2</sup> or greater, in order to avoid inadvertent discharge, the balers shall be equipped with a device, provided on the machine, either to secure the last bale in position or to eject it.

## 5.4 Requirements for round balers

### 5.4.1 Protection against hazards related to clearing blockages

**5.4.1.1** The pick-up and feeding elements, which can have a blockage, shall be fitted with a device preventing these elements from being restarted after clearing the blockage without an intentional action by the operator (e.g. torque limiter reset, PTO re-engagement, unplugging device). The use of shear bolts alone does not fulfil this requirement.

**5.4.1.2** If the machine is fitted with rotating feeding elements between pick-up and bale chamber, these feeding elements shall be fitted with a device to remove blockages.

If the device to remove blockages is a reversing mechanism, this device shall be either

- controlled from the operator station by means of a hold-to-run control located such that the danger zone cannot be reached when operating the control, or
- operable only manually and when the PTO drive is disconnected or power to the machine is otherwise interrupted.

### 5.4.2 Bale ejection door — rear tailgate

**5.4.2.1** At the back of the machine, power transmission components (e.g. sprockets, chains, rotating shafts) shall be guarded according to provisions for moving transmission parts against inadvertent contact. The guards may be fixed parts of the machine or part of the bale ejection door. This requirement does not apply to belts and rollers between sidewalls above the safety distances given in ISO 13857:2008, 4.2.1.2 or 4.2.1.3.

**5.4.2.2** To avoid the hazard of inadvertent lowering of the rear tail-gate during maintenance, a device in accordance with 4.8 of ISO 4254-1:2008 shall be present on the machine. If the device is a mechanical support, this shall not be detachable.

## 6 Verification of the safety requirements and/or protective measures

Verification of the requirements specified in Clause 5 shall be made by means of inspection, calculation or testing. Dimensions, where given, shall be verified by measurements. Controls shall be verified by a function test and positional measurements; guards by functional test.

## 7 Information for use

### 7.1 Operator's manual

**7.1.1** The content and presentation shall be in accordance with ISO 3600.

**7.1.2** Comprehensive instructions and information on all aspects of the safe use of the machine, including suitable clothing and personal protective equipment requirements and the need for training, if necessary, shall be provided by the manufacturer in the operator's manual.

**7.1.3** The operator's manual shall be in accordance with ISO 4254-1:2008, 8.1.3. See also ISO 12100:—, 6.4.

**7.1.4** In particular, the following information shall be provided:

- a) that guards be closed before starting and/or resuming operation of the machine;
- b) that all crushing, shearing and entanglement points related to the drawbar and to the pick-up and to the feeding elements be noted;
- c) that the operator shut the engine and PTO off and wait for all movement to stop before approaching the baler; in addition, that the flywheel immobilizing device, when installed, be applied;
- d) the risks of injury if hydraulic lines rupture;
- e) the maximum allowed working pressure of the baler hydraulic system;
- f) the procedure to be followed for the threading of the twine, when the twine breaks and the feeding of the twine in the knotter;
- g) the quality and properties of the tying material to be used (twine, net, plastic foil);
- h) for round balers, the hazards related to access to the baling compartment, the movement of the rear door, the ejection of bales and the need to ensure that nobody stands nearby;
- i) the necessity of using a (PTO) drive shaft assembly equipped with a guard in good condition when a PTO drive is required;
- j) the importance of regular maintenance of the baler and regular clearing of wrapped crop or tying material to reduce the possibility of fire;
- k) the techniques of operation to reduce the possibility of blockages from occurring;
- l) the hazards related to clearing blockages from the machine and, in particular, when the pick-up mechanism continues to run although there is a blockage, the clean-out procedures to be followed;
- m) the need to shut the tractor engine off and wait for all movement to stop before manually clearing any blockages or wrapped material;
- n) the need to replace the shear bolts, if any, after breaking, by new ones with the same characteristics;

- o) the hazards related to manually feeding the twine on to the bale to start the twine-tying process as the bale is rotating;
- p) the procedures to be followed for changing the knives (e.g. stop the machine and constrain the flywheel);
- q) for balers capable of forming bales with a cross-section of 0,25 m<sup>2</sup> or greater, information to ensure that the last bale is secured or removed before the baler is taken on public roads;
- r) the procedure to be followed when changing the position of the drawbar;
- s) the need to take into account the direction of the slope when discharging round bales and the need to warn operators to be aware of the risks from bales rolling downhill when working on slopes;
- t) for round balers, the risks related to machine stability when operating on side slopes, and that the baler can tip sideways if it strikes a hole, a ditch or other irregularity in the field, especially with the discharging door open;
- u) information regarding the operation of the machine in combination with other equipment (e.g. bale wrapper, baler collecting device).

## 7.2 Marking

### 7.2.1 General

All machines shall be marked in accordance with 8.3 of ISO 4254-1:2008.

NOTE Legal requirements can require additional information.

### 7.2.2 Instructional signs

Instructional signs relating to equipment operation, servicing and care shall have an appearance, especially colour, different from the safety signs on the equipment.

Nominal rotation frequency and direction of rotation of the power input connection (marked by an arrow) shall be provided on the machine.

### 7.2.3 Safety signs

**7.2.3.1** Safety signs shall be appropriately displayed when necessary to alert the operator and others of the risk of personal injury during normal operation and servicing.

**7.2.3.2** Safety signs shall conform to the requirements of ISO 11684.

**7.2.3.3** In particular, safety signs shall be provided on the machine drawing attention to:

- a) the crushing and shearing points when changing the drawbar position;
- b) the run-down time of the flywheel;
- c) the crushing hazard when the bale ejection door is open;
- d) the risk of contact with moving parts of the tying mechanism;
- e) on balers equipped with a flywheel immobilizing device, the use and control of this device.



## Bibliography

- [1] ISO/TS 28923:2007, *Agricultural machinery — Guards for moving parts of power transmission — Guard opening with tool*
- [2] ISO/TS 28924:2007, *Agricultural machinery — Guards for moving parts of power transmission — Guard opening without tool*





# British Standards Institution (BSI)

BSI is the national body responsible for preparing British Standards and other standards-related publications, information and services.

BSI is incorporated by Royal Charter. British Standards and other standardization products are published by BSI Standards Limited.

## About us

We bring together business, industry, government, consumers, innovators and others to shape their combined experience and expertise into standards-based solutions.

The knowledge embodied in our standards has been carefully assembled in a dependable format and refined through our open consultation process. Organizations of all sizes and across all sectors choose standards to help them achieve their goals.

## Information on standards

We can provide you with the knowledge that your organization needs to succeed. Find out more about British Standards by visiting our website at [bsigroup.com/standards](http://bsigroup.com/standards) or contacting our Customer Services team or Knowledge Centre.

## Buying standards

You can buy and download PDF versions of BSI publications, including British and adopted European and international standards, through our website at [bsigroup.com/shop](http://bsigroup.com/shop), where hard copies can also be purchased.

If you need international and foreign standards from other Standards Development Organizations, hard copies can be ordered from our Customer Services team.

## Subscriptions

Our range of subscription services are designed to make using standards easier for you. For further information on our subscription products go to [bsigroup.com/subscriptions](http://bsigroup.com/subscriptions).

With **British Standards Online (BSOL)** you'll have instant access to over 55,000 British and adopted European and international standards from your desktop. It's available 24/7 and is refreshed daily so you'll always be up to date.

You can keep in touch with standards developments and receive substantial discounts on the purchase price of standards, both in single copy and subscription format, by becoming a **BSI Subscribing Member**.

**PLUS** is an updating service exclusive to BSI Subscribing Members. You will automatically receive the latest hard copy of your standards when they're revised or replaced.

To find out more about becoming a BSI Subscribing Member and the benefits of membership, please visit [bsigroup.com/shop](http://bsigroup.com/shop).

With a **Multi-User Network Licence (MUNL)** you are able to host standards publications on your intranet. Licences can cover as few or as many users as you wish. With updates supplied as soon as they're available, you can be sure your documentation is current. For further information, email [bsmusales@bsigroup.com](mailto:bsmusales@bsigroup.com).

## BSI Group Headquarters

389 Chiswick High Road London W4 4AL UK

## Revisions

Our British Standards and other publications are updated by amendment or revision.

We continually improve the quality of our products and services to benefit your business. If you find an inaccuracy or ambiguity within a British Standard or other BSI publication please inform the Knowledge Centre.

## Copyright

All the data, software and documentation set out in all British Standards and other BSI publications are the property of and copyrighted by BSI, or some person or entity that owns copyright in the information used (such as the international standardization bodies) and has formally licensed such information to BSI for commercial publication and use. Except as permitted under the Copyright, Designs and Patents Act 1988 no extract may be reproduced, stored in a retrieval system or transmitted in any form or by any means – electronic, photocopying, recording or otherwise – without prior written permission from BSI. Details and advice can be obtained from the Copyright & Licensing Department.

## Useful Contacts:

### Customer Services

**Tel:** +44 845 086 9001

**Email (orders):** [orders@bsigroup.com](mailto:orders@bsigroup.com)

**Email (enquiries):** [cservices@bsigroup.com](mailto:cservices@bsigroup.com)

### Subscriptions

**Tel:** +44 845 086 9001

**Email:** [subscriptions@bsigroup.com](mailto:subscriptions@bsigroup.com)

### Knowledge Centre

**Tel:** +44 20 8996 7004

**Email:** [knowledgecentre@bsigroup.com](mailto:knowledgecentre@bsigroup.com)

### Copyright & Licensing

**Tel:** +44 20 8996 7070

**Email:** [copyright@bsigroup.com](mailto:copyright@bsigroup.com)



...making excellence a habit.™