

BS EN ISO 4210-8:2014

Incorporating corrigendum November 2014



BSI Standards Publication

Cycles — Safety requirements for bicycles

Part 8: Pedal and drive system test methods
(ISO 4210-8:2014)

bsi.

...making excellence a habit.™

National foreword

This British Standard is the UK implementation of EN ISO 4210-8:2014. Together with BS EN ISO 4210-1:2014, BS EN ISO 4210-2:2014, BS EN ISO 4210-3:2014, BS EN ISO 4210-4:2014, BS EN ISO 4210-5:2014, BS EN ISO 4210-6:2014, BS EN ISO 4210-7:2014, BS EN ISO 4210-9:2014 it supersedes BS EN 14764:2005, BS EN 14766:2005 and BS EN 14781:2005, which are withdrawn.

The UK participation in its preparation was entrusted to Technical Committee GME/25, Cycles.

A list of organizations represented on this committee can be obtained on request to its secretary.

This publication does not purport to include all the necessary provisions of a contract. Users are responsible for its correct application.

© The British Standards Institution 2014.
Published by BSI Standards Limited 2014

ISBN 978 0 580 88989 9

ICS 43.150

Compliance with a British Standard cannot confer immunity from legal obligations.

This British Standard was published under the authority of the Standards Policy and Strategy Committee on 30 September 2014.

Amendments/corrigenda issued since publication

Date	Text affected
30 November 2014	CEN Correction Notice 12 November 2014 implements ISO corrected text 1 November 2014: Modification to item 4 in the key of Figure 6

English Version

**Cycles - Safety requirements for bicycles - Part 8: Pedal and
drive system test methods (ISO 4210-8:2014, Corrected version
2014-11-01)**

Cycles - Exigences de sécurité des bicyclettes - Partie 8:
Méthodes d'essai des pédales et du pédalier (ISO 4210-
8:2014, Version corrigée 2014-11-01)

Fahrräder - Sicherheitstechnische Anforderungen an
Fahrräder - Teil 8: Prüfverfahren für Pedal und
Antriebssystem (ISO 4210-8:2014, korrigierte Fassung
2014-11-01)

This European Standard was approved by CEN on 21 June 2014.

CEN members are bound to comply with the CEN/CENELEC Internal Regulations which stipulate the conditions for giving this European Standard the status of a national standard without any alteration. Up-to-date lists and bibliographical references concerning such national standards may be obtained on application to the CEN-CENELEC Management Centre or to any CEN member.

This European Standard exists in three official versions (English, French, German). A version in any other language made by translation under the responsibility of a CEN member into its own language and notified to the CEN-CENELEC Management Centre has the same status as the official versions.

CEN members are the national standards bodies of Austria, Belgium, Bulgaria, Croatia, Cyprus, Czech Republic, Denmark, Estonia, Finland, Former Yugoslav Republic of Macedonia, France, Germany, Greece, Hungary, Iceland, Ireland, Italy, Latvia, Lithuania, Luxembourg, Malta, Netherlands, Norway, Poland, Portugal, Romania, Slovakia, Slovenia, Spain, Sweden, Switzerland, Turkey and United Kingdom.



EUROPEAN COMMITTEE FOR STANDARDIZATION
COMITÉ EUROPÉEN DE NORMALISATION
EUROPÄISCHES KOMITEE FÜR NORMUNG

CEN-CENELEC Management Centre: Avenue Marnix 17, B-1000 Brussels

Foreword

This document (EN ISO 4210-8:2014) has been prepared by Technical Committee ISO/TC 149 "Cycles" in collaboration with Technical Committee CEN/TC 333 "Cycles" the secretariat of which is held by UNI.

This European Standard shall be given the status of a national standard, either by publication of an identical text or by endorsement, at the latest by January 2015, and conflicting national standards shall be withdrawn at the latest by July 2015.

Attention is drawn to the possibility that some of the elements of this document may be the subject of patent rights. CEN [and/or CENELEC] shall not be held responsible for identifying any or all such patent rights.

This document supersedes EN 14764:2005, EN 14766:2005, EN 14781:2005.

This document has been prepared under a mandate given to CEN by the European Commission and the European Free Trade Association.

According to the CEN-CENELEC Internal Regulations, the national standards organizations of the following countries are bound to implement this European Standard: Austria, Belgium, Bulgaria, Croatia, Cyprus, Czech Republic, Denmark, Estonia, Finland, Former Yugoslav Republic of Macedonia, France, Germany, Greece, Hungary, Iceland, Ireland, Italy, Latvia, Lithuania, Luxembourg, Malta, Netherlands, Norway, Poland, Portugal, Romania, Slovakia, Slovenia, Spain, Sweden, Switzerland, Turkey and the United Kingdom.

Endorsement notice

The text of ISO 4210-8:2014 , Corrected version 2014-11-01 has been approved by CEN as EN ISO 4210-8:2014 without any modification.

Contents

Page

Foreword	iv
Introduction	v
1 Scope	1
2 Normative references	1
3 Terms and definitions	1
4 Test methods	1
4.1 Pedal — Static strength test.....	1
4.2 Pedal — Impact test.....	2
4.3 Pedal — Dynamic durability test.....	4
4.4 Drive system — Static strength test.....	4
4.5 Drive belt — Tensile strength test.....	5
4.6 Crank assembly — Fatigue test.....	6
Bibliography	9

Foreword

ISO (the International Organization for Standardization) is a worldwide federation of national standards bodies (ISO member bodies). The work of preparing International Standards is normally carried out through ISO technical committees. Each member body interested in a subject for which a technical committee has been established has the right to be represented on that committee. International organizations, governmental and non-governmental, in liaison with ISO, also take part in the work. ISO collaborates closely with the International Electrotechnical Commission (IEC) on all matters of electrotechnical standardization.

The procedures used to develop this document and those intended for its further maintenance are described in the ISO/IEC Directives, Part 1. In particular the different approval criteria needed for the different types of ISO documents should be noted. This document was drafted in accordance with the editorial rules of the ISO/IEC Directives, Part 2 (see www.iso.org/directives).

Attention is drawn to the possibility that some of the elements of this document may be the subject of patent rights. ISO shall not be held responsible for identifying any or all such patent rights. Details of any patent rights identified during the development of the document will be in the Introduction and/or on the ISO list of patent declarations received (see www.iso.org/patents).

Any trade name used in this document is information given for the convenience of users and does not constitute an endorsement.

For an explanation on the meaning of ISO specific terms and expressions related to conformity assessment, as well as information about ISO's adherence to the WTO principles in the Technical Barriers to Trade (TBT) see the following URL: Foreword - Supplementary information

The committee responsible for this document is ISO/TC 149, *Cycles*, Subcommittee SC 1, *Cycles and major sub-assemblies*.

This first edition of ISO 4210-8, together with ISO 4210-1, ISO 4210-2, ISO 4210-3, ISO 4210-4, ISO 4210-5, ISO 4210-6, ISO 4210-7, and ISO 4210-9 cancels and replaces ISO 4210:1996, which has been technically revised.

ISO 4210 consists of the following parts, under the general title *Cycles — Safety requirements for bicycles*:

- *Part 1: Terms and definitions*
- *Part 2: Requirements for city and trekking, young adult, mountain and racing bicycles*
- *Part 3: Common test methods*
- *Part 4: Braking test methods*
- *Part 5: Steering test methods*
- *Part 6: Frame and fork test methods*
- *Part 7: Wheels and rims test methods*
- *Part 8: Pedals and drive system test methods*
- *Part 9: Saddles and seat-post test methods*

This corrected version of ISO 4210-8:2014 incorporates a modification in the key of Figure 6, item 4.

Introduction

This International Standard has been developed in response to demand throughout the world, and the aim has been to ensure that bicycles manufactured in compliance with this International Standard will be as safe as is practically possible. The tests have been designed to ensure the strength and durability of individual parts as well as of the bicycle as a whole, demanding high quality throughout and consideration of safety aspects from the design stage onwards.

The scope has been limited to safety considerations, and has specifically avoided standardization of components.

If the bicycle is to be used on public roads, national regulations apply.

Cycles — Safety requirements for bicycles —

Part 8: Pedal and drive system test methods

1 Scope

This part of ISO 4210 specifies pedal and drive system test methods for ISO 4210-2.

2 Normative references

The following documents, in whole or in part, are normatively referenced in this document and are indispensable for its application. For dated references, only the edition cited applies. For undated references, the latest edition of the referenced document (including any amendments) applies.

ISO 4210-1, *Cycles – Safety requirements for bicycles – Part 1: Terms and definitions*

ISO 4210-3:2014, *Cycles – Safety requirements for bicycles – Part 3: Common test methods*

IEC 60529:2001, *Degrees of protection provided by enclosures (IP Code)*

3 Terms and definitions

For the purposes of this document, the terms and definitions given in ISO 4210-1 apply.

4 Test methods

4.1 Pedal — Static strength test

Screw the pedal-spindle securely into a suitable rigid fixture with its axis horizontal, as shown in [Figure 1](#), and apply a vertically downward force of 1 500 N for 1 min to the centre of the pedal as shown in [Figure 1](#). Release the force and examine the pedal assembly and the spindle.

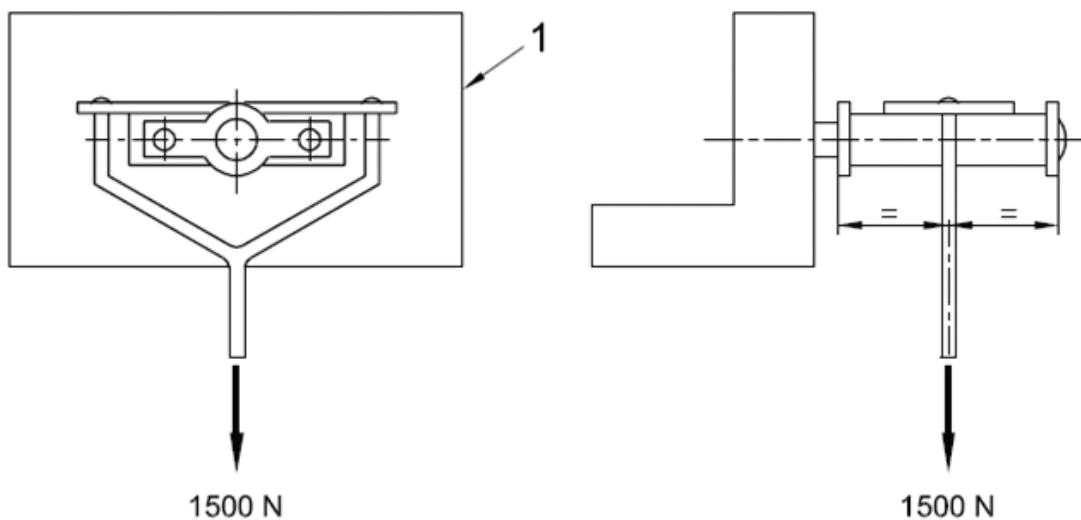

Key

1 rigid mount

Figure 1 — Pedal/pedal-spindle assembly — Static strength test

4.2 Pedal — Impact test

Screw the pedal-spindle securely into a suitable rigid fixture with its axis horizontal as shown in [Figure 3](#) and release a striker of the design shown in [Figure 2](#) and mass of 15 kg from a height of 400 mm to strike the pedal at the centre of the pedal. The width of the striker shall be wider than the width of the tread surface.

NOTE See ISO 4210-3:2014, Annex B.

Dimensions in millimetres

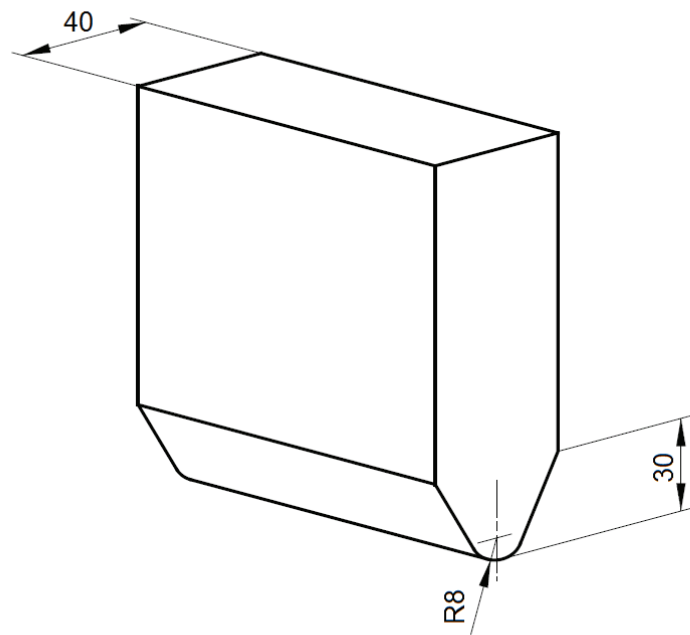

Figure 2 — Striker dimensions

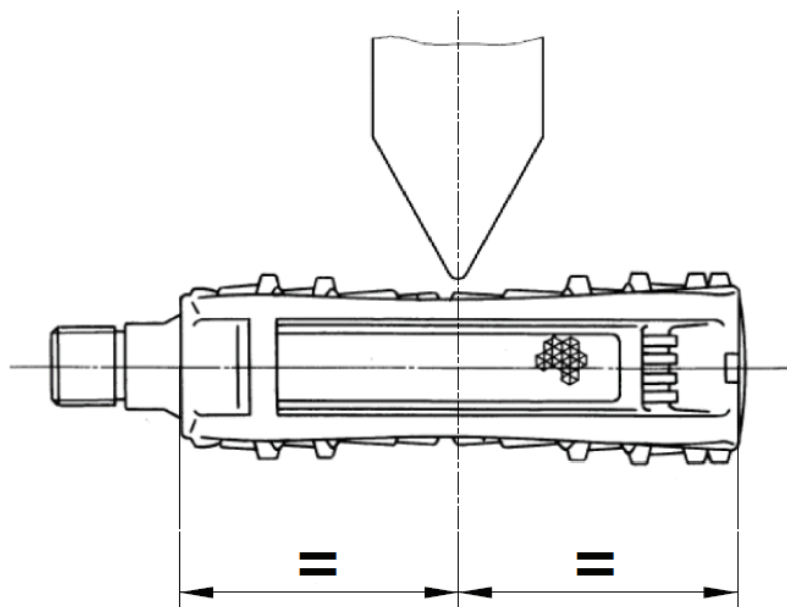

Figure 3 — Position of impact

4.3 Pedal — Dynamic durability test

Screw each pedal securely into a threaded hole in a rotatable test shaft as shown in [Figure 4](#) and suspend a mass of M at the centre of the pedal width by means of a tension spring to each pedal, the object of the springs being to minimize oscillations of the load. The masses are given in [Table 1](#).

Drive the shaft at a speed not exceeding 100 min^{-1} for a total of 100 000 revolutions. If the pedals are provided with two tread surfaces, they shall be turned through 180° after 50 000 revolutions.

Table 1 — Masses on pedal

Bicycle type	City and trekking bicycles	Young adult bicycles	Mountain bicycles	Racing bicycles
Mass, M kg	80	80	90	90

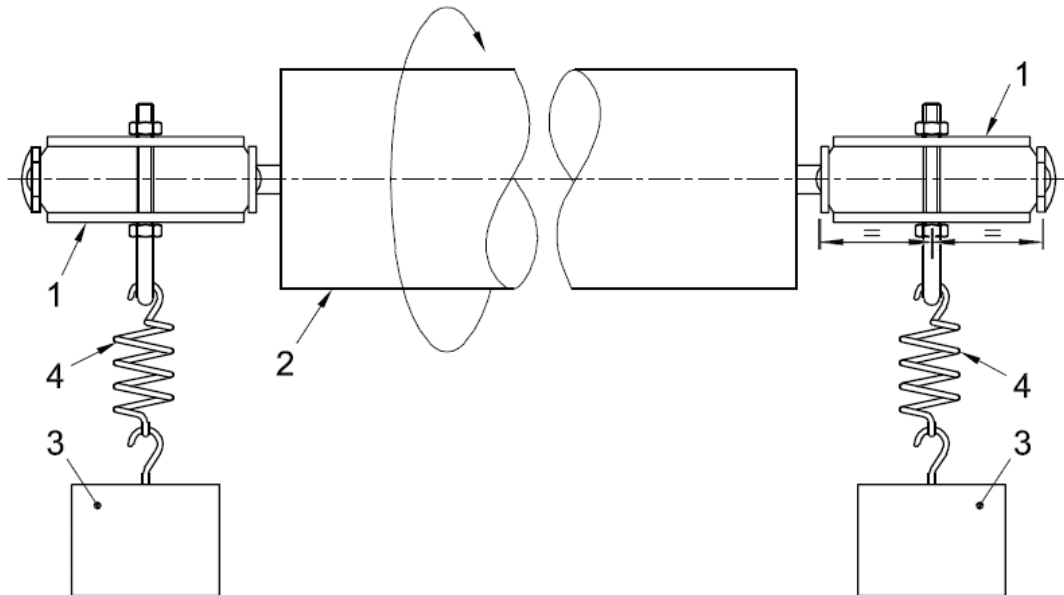

Key

- 1 pedal
- 2 test shaft
- 3 mass
- 4 tension spring

Figure 4 — Pedal/pedal-spindle — Dynamic durability test

4.4 Drive system — Static strength test

4.4.1 Test method for drive system with chain

4.4.1.1 General

Conduct the drive system static load test on an assembly comprising the frame, pedals, transmission system, rear wheel assembly, and, if appropriate, the gear-change mechanism. Support the frame with the central plane vertical and with the rear wheel held at the rim to prevent the wheel from rotating.

4.4.1.2 Single-speed system

With the non-drive side crank in the forward position, apply a force, F_1 , increasing gradually to 1 500 N vertically downwards to the centre of the non-drive side pedal. Maintain this force for 1 min.

Should the system yield or the drive-sprockets tighten, such that the crank rotates while under load to a position more than 30° below the horizontal, remove the test force, return the crank to the horizontal position or some appropriate position above the horizontal to take account of yield or movement, and repeat the test.

On completion of the test on the non-drive side crank, repeat the test with the drive side crank in the forward position and with the force applied to the drive side pedal.

4.4.1.3 Multi-speed system

- a) Conduct the tests described in [4.4.1.2](#) with the transmission correctly adjusted in its highest gear.
- b) Conduct the tests generally as described in [4.4.1.2](#) with the transmission correctly adjusted in its lowest gear but, where appropriate, with the maximum force, F_1 , adjusted to suit the particular gear ratio. Thus:

The maximum force, F_1 , shall be a function of the lowest gear ratio, N_c/N_s ,

where

F_1 is the force applied to the pedal, expressed in newton (N);

N_c is the number of teeth on the smallest chain wheel (front);

N_s is the number of teeth on the largest sprocket (rear).

Where the ratio N_c/N_s has a value equal to or greater than 1, the force, F_1 , shall be 1 500 N; but where the ratio N_c/N_s has a value less than 1, the force, F_1 , shall be reduced in proportion to the lowest gear ratio. Thus:

F_1 is $1\,500 \times N_c/N_s$.

4.4.2 Test method for drive system with belt

The sample in its fully finished condition (with teeth, if any) shall be submitted to a water spray conditioning equivalent to IPX4 specified in IEC 60529:2001, 14.2.4 during 10 min. Application of the loading shall be done within 20 min after conditioning.

- a) If the drive system is a single-speed system, conduct the tests as described in [4.4.1.2](#).
- b) If the drive system is a multi-speed system, conduct the tests as described in [4.4.1.3](#).

4.5 Drive belt — Tensile strength test

Set up a fixture with two drive pulleys that are similar or identical as shown in [Figure 5](#). At least one pulley should be free to rotate. Increase the tensile load gradually until the tension load of the belt reaches 4 000 N.

NOTE 4 000 N is the tension load within the belt and requires a load F of 8 000 N to achieve this tension load.

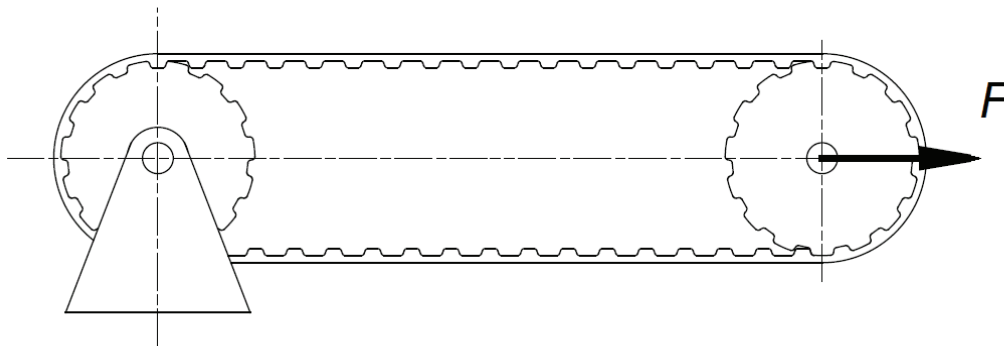

Figure 5 — Drive belt — Tensile strength test

4.6 Crank assembly — Fatigue test

4.6.1 General

Two types of fatigue test are specified for mountain bicycles: the first test with the cranks positioned at 45° to the horizontal to simulate the forces due to pedalling, and the second test with the cranks positioned at 30° to the horizontal, which has been found to simulate the forces due the rider standing on the pedals during the descent of hills. The two tests shall be conducted on separate assemblies.

4.6.2 Test method with the cranks at 45° to the horizontal

Mount the assembly of the two pedal-spindle adaptors, the drive side and non-drive side crank, the chain wheel set (or other drive component), and the bottom-bracket spindle located on its normal-production bearings in a fixture with bearing housings representative of the bottom-bracket (as shown in [Figure 6](#)). Incline the cranks at 45° to the horizontal.

Prevent rotation by locating a suitable length of drive chain around the largest or only chain wheel and securing it firmly to a suitable support, or, for any other type of transmission (e.g. belt- or shaft-drive) by securing the first stage of the transmission.

NOTE It is permissible to have the non-drive side crank in either of the two positions shown in [Figure 6](#), provided the test force is applied in the appropriate direction as specified in the next paragraph.

Apply repeated, vertical, dynamic forces of F_2 alternately to the pedal-spindle adaptors of the drive side and non-drive side crank at a distance of 65 mm from the outboard face of each crank (as shown in [Table 2](#) and [Figure 6](#)) for C test cycles (where one test cycle consists of the application of the two forces). The direction of the force on the drive side crank shall be downwards and that on the non-drive side crank shall be upwards for a rearward-pointing crank, or downwards for a forward-pointing crank. During application of these test forces, ensure that the force on a pedal-spindle adaptor falls to 5 % or less of the peak force before commencing application of the test force to the other pedal-spindle adaptor. The maximum test frequency shall be maintained as specified in ISO 4210-3:2014, 4.5.

Table 2 — Forces on pedal-spindle and test cycles

Bicycle type	City and trekking bicycles	Young adult bicycles	Mountain bicycles	Racing bicycles
Force, F_2 N	1 300	1 300	1 800	1 800
Test cycles, C	100 000	100 000	50 000	100 000

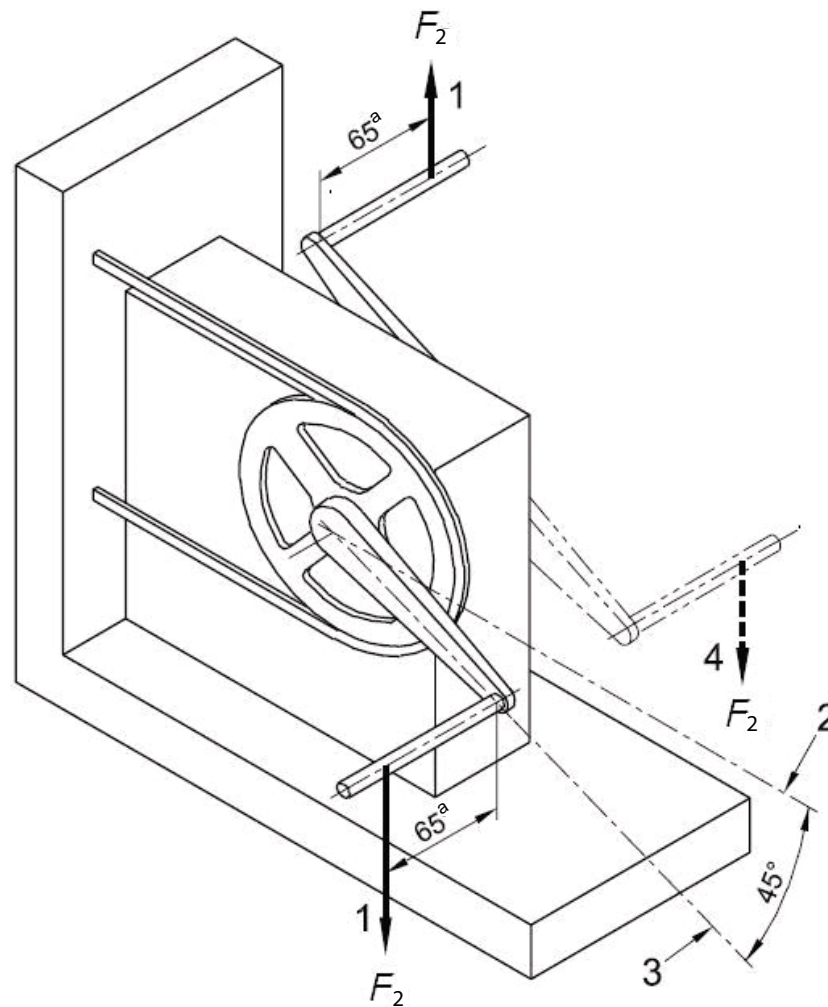

Key

- 1 repeated test force
- 2 horizontal axis
- 3 axis of crank
- 4 alternative non-drive side crank arrangement
- a From outboard face of crank.

Figure 6 — Crank assembly — Fatigue test with cranks at 45° (typical test arrangement)

4.6.3 Test method with the cranks at 30° to the horizontal for mountain bicycles

Mount the assembly of the two pedal-spindle adaptors, the drive side and non-drive side crank, the chain wheel set (or other drive component), and the bottom-bracket spindle located on its normal-production bearings in a fixture with bearing housings representative of the bottom-bracket, as shown in [Figure 7](#). Incline the cranks at 30° to the horizontal as shown in [Figure 7](#). Restrain the non-drive side crank to the base of the test machine by a device attached to the pedal-spindle at a distance of 65 mm from the outboard face of the crank.

Apply a repeated, vertically downward, dynamic force of 1 800 N to the pedal-spindle of the drive side crank at a distance of 65 mm from the outboard face of the crank (as shown in [Figure 7](#)) for 50 000 cycles. The maximum test frequency shall be maintained as specified in ISO 4210-3:2014, 4.5.

Dimensions in millimetres

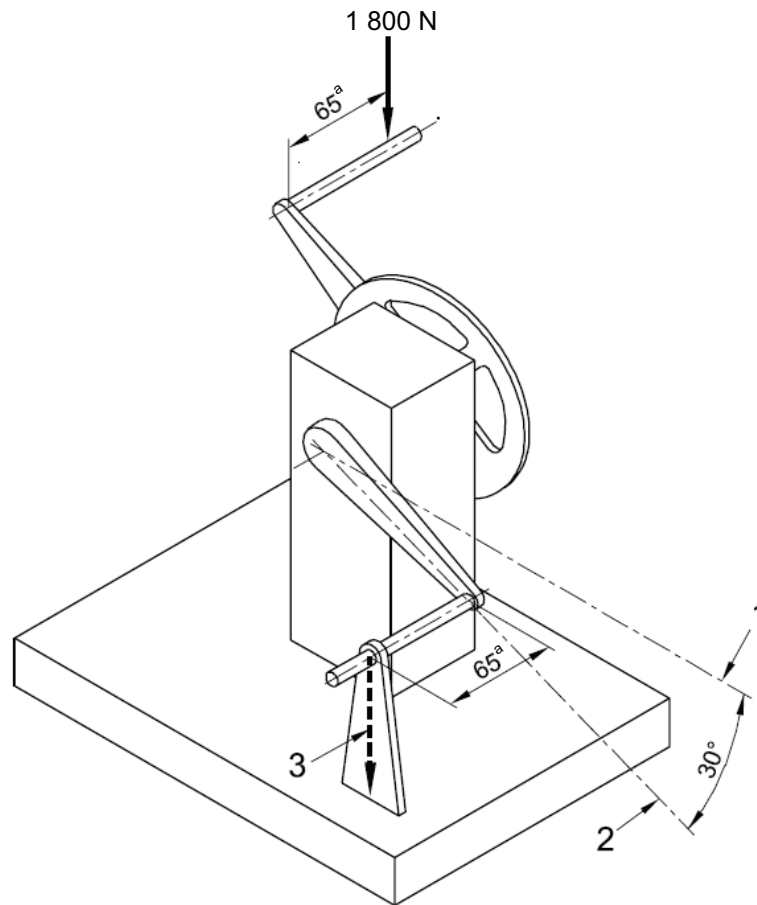

Key

- 1 horizontal axis
- 2 axis of crank
- 3 reactive force (equal and opposite to test force)
- a From outboard face of crank.

Figure 7 — Crank assembly — Fatigue test with cranks at 30° (typical test arrangement)

Bibliography

- [1] ISO 4210-2:2014, *Cycles — Safety requirements for bicycles — Part 2: Requirements for city and trekking, young adult, mountain and racing bicycles*

British Standards Institution (BSI)

BSI is the national body responsible for preparing British Standards and other standards-related publications, information and services.

BSI is incorporated by Royal Charter. British Standards and other standardization products are published by BSI Standards Limited.

About us

We bring together business, industry, government, consumers, innovators and others to shape their combined experience and expertise into standards-based solutions.

The knowledge embodied in our standards has been carefully assembled in a dependable format and refined through our open consultation process. Organizations of all sizes and across all sectors choose standards to help them achieve their goals.

Information on standards

We can provide you with the knowledge that your organization needs to succeed. Find out more about British Standards by visiting our website at bsigroup.com/standards or contacting our Customer Services team or Knowledge Centre.

Buying standards

You can buy and download PDF versions of BSI publications, including British and adopted European and international standards, through our website at bsigroup.com/shop, where hard copies can also be purchased.

If you need international and foreign standards from other Standards Development Organizations, hard copies can be ordered from our Customer Services team.

Subscriptions

Our range of subscription services are designed to make using standards easier for you. For further information on our subscription products go to bsigroup.com/subscriptions.

With **British Standards Online (BSOL)** you'll have instant access to over 55,000 British and adopted European and international standards from your desktop. It's available 24/7 and is refreshed daily so you'll always be up to date.

You can keep in touch with standards developments and receive substantial discounts on the purchase price of standards, both in single copy and subscription format, by becoming a **BSI Subscribing Member**.

PLUS is an updating service exclusive to BSI Subscribing Members. You will automatically receive the latest hard copy of your standards when they're revised or replaced.

To find out more about becoming a BSI Subscribing Member and the benefits of membership, please visit bsigroup.com/shop.

With a **Multi-User Network Licence (MUNL)** you are able to host standards publications on your intranet. Licences can cover as few or as many users as you wish. With updates supplied as soon as they're available, you can be sure your documentation is current. For further information, email bsmusales@bsigroup.com.

BSI Group Headquarters

389 Chiswick High Road London W4 4AL UK

Revisions

Our British Standards and other publications are updated by amendment or revision.

We continually improve the quality of our products and services to benefit your business. If you find an inaccuracy or ambiguity within a British Standard or other BSI publication please inform the Knowledge Centre.

Copyright

All the data, software and documentation set out in all British Standards and other BSI publications are the property of and copyrighted by BSI, or some person or entity that owns copyright in the information used (such as the international standardization bodies) and has formally licensed such information to BSI for commercial publication and use. Except as permitted under the Copyright, Designs and Patents Act 1988 no extract may be reproduced, stored in a retrieval system or transmitted in any form or by any means – electronic, photocopying, recording or otherwise – without prior written permission from BSI. Details and advice can be obtained from the Copyright & Licensing Department.

Useful Contacts:

Customer Services

Tel: +44 845 086 9001

Email (orders): orders@bsigroup.com

Email (enquiries): cservices@bsigroup.com

Subscriptions

Tel: +44 845 086 9001

Email: subscriptions@bsigroup.com

Knowledge Centre

Tel: +44 20 8996 7004

Email: knowledgecentre@bsigroup.com

Copyright & Licensing

Tel: +44 20 8996 7070

Email: copyright@bsigroup.com



...making excellence a habit.™