

BS EN ISO 4064-2:2014

Incorporating corrigendum November 2014



BSI Standards Publication

Water meters for cold potable water and hot water

Part 2: Test methods

bsi.

...making excellence a habit.™

National foreword

This British Standard is the UK implementation of EN ISO 4064-2:2014. It supersedes BS EN 14154-3:2005+A2:2011, which is withdrawn.

The UK participation in its preparation was entrusted by Technical Committee CPI/30, Measurement of fluid flow in closed conduits, to Subcommittee CPI/30/7, Volume flow-rate methods.

A list of organizations represented on this subcommittee can be obtained on request to its secretary.

This publication does not purport to include all the necessary provisions of a contract. Users are responsible for its correct application.

© The British Standards Institution 2014.
Published by BSI Standards Limited 2014

ISBN 978 0 580 88388 0

ICS 91.140.60

Compliance with a British Standard cannot confer immunity from legal obligations.

This British Standard was published under the authority of the Standards Policy and Strategy Committee on 30 June 2014.

Amendments/corrigenda issued since publication

Date	Text affected
30 November 2014	Implementation of CEN Correction Notice 20 August 2014: Updated supersession details in national and CEN foreword
30 November 2014	Implementation of CEN Correction Notice 15 October 2014: Corrected French title in CEN title page

English Version

Water meters for cold potable water and hot water - Part 2: Test methods (ISO 4064-2:2014)

Compteurs d'eau potable froide et d'eau chaude - Partie 2:
Méthodes d'essai (ISO 4064-2:2014)

Wasserzähler zum Messen von kaltem Trinkwasser und
heißem Wasser - Teil 2: Prüfverfahren (ISO 4064-2:2014)

This European Standard was approved by CEN on 21 September 2013.

CEN members are bound to comply with the CEN/CENELEC Internal Regulations which stipulate the conditions for giving this European Standard the status of a national standard without any alteration. Up-to-date lists and bibliographical references concerning such national standards may be obtained on application to the CEN-CENELEC Management Centre or to any CEN member.

This European Standard exists in three official versions (English, French, German). A version in any other language made by translation under the responsibility of a CEN member into its own language and notified to the CEN-CENELEC Management Centre has the same status as the official versions.

CEN members are the national standards bodies of Austria, Belgium, Bulgaria, Croatia, Cyprus, Czech Republic, Denmark, Estonia, Finland, Former Yugoslav Republic of Macedonia, France, Germany, Greece, Hungary, Iceland, Ireland, Italy, Latvia, Lithuania, Luxembourg, Malta, Netherlands, Norway, Poland, Portugal, Romania, Slovakia, Slovenia, Spain, Sweden, Switzerland, Turkey and United Kingdom.



EUROPEAN COMMITTEE FOR STANDARDIZATION
COMITÉ EUROPÉEN DE NORMALISATION
EUROPÄISCHES KOMITEE FÜR NORMUNG

CEN-CENELEC Management Centre: Avenue Marnix 17, B-1000 Brussels

Foreword

This document (EN ISO 4064-2:2014) has been prepared by Technical Committee ISO/TC 30 “Measurement of fluid flow in closed conduits” in collaboration with Technical Committee CEN/TC 92 “Water meters” the secretariat of which is held by SNV.

This European Standard shall be given the status of a national standard, either by publication of an identical text or by endorsement, at the latest by December 2014, and conflicting national standards shall be withdrawn at the latest by June 2017.

Attention is drawn to the possibility that some of the elements of this document may be the subject of patent rights. CEN [and/or CENELEC] shall not be held responsible for identifying any or all such patent rights.

This document supersedes EN 14154-3:2005+A2:2011.

This document has been prepared under a mandate given to CEN by the European Commission and the European Free Trade Association, and supports essential requirements of EU Directive(s).

For relationship with EU Directive(s), see informative Annex ZA, which is an integral part of this document.

According to the CEN-CENELEC Internal Regulations, the national standards organizations of the following countries are bound to implement this European Standard: Austria, Belgium, Bulgaria, Croatia, Cyprus, Czech Republic, Denmark, Estonia, Finland, Former Yugoslav Republic of Macedonia, France, Germany, Greece, Hungary, Iceland, Ireland, Italy, Latvia, Lithuania, Luxembourg, Malta, Netherlands, Norway, Poland, Portugal, Romania, Slovakia, Slovenia, Spain, Sweden, Switzerland, Turkey and the United Kingdom.

Endorsement notice

The text of ISO 4064-2:2014 has been approved by CEN as EN ISO 4064-2:2014 without any modification.

Annex ZA
(informative)
**Relationship between this European Standard and the Essential
Requirements of EU Directive 2004/22/EC**

This European Standard has been prepared under a mandate given to CEN by the European Commission and the European Free Trade Association to provide one means of conforming to Essential Requirements of the New Approach Directive 2004/22/EC, *Measuring instruments directive*.

Once this standard is cited in the Official Journal of the European Communities under that Directive and has been implemented as a national standard in at least one Member State, compliance with the normative clauses of this standard confers, within the limits of the scope of this standard, a presumption of conformity with the relevant Essential Requirements of that Directive and associated EFTA regulations.

WARNING: Other requirements and other EU Directives may be applicable to the products falling within the scope of this standard.

Contents

Page

Foreword	vi
1 Scope	1
2 Normative references	1
3 Terms and definitions	2
4 Reference conditions	2
5 Symbols, units and equations	3
6 External examination	3
6.1 General.....	3
6.2 Object of the examination.....	3
6.3 Preparation.....	3
6.4 Examination procedures.....	4
7 Performance tests for all water meters	8
7.1 General.....	8
7.2 Required conditions for all tests.....	8
7.3 Static pressure test (ISO 4064-1:2014 OIML R 49-1:2013, 4.2.10).....	9
7.4 Determination of intrinsic errors (of indication) (ISO 4064-1:2014 OIML R 49-1:2013, 7.2.3).....	10
7.5 Water temperature test (ISO 4064-1:2014 OIML R 49-1:2013, 4.2.8).....	18
7.6 Overload water temperature test (ISO 4064-1:2014 OIML R 49-1:2013, 7.2.5).....	18
7.7 Water pressure test (ISO 4064-1:2014 OIML R 49-1:2013, 4.2.8).....	19
7.8 Reverse flow test (ISO 4064-1:2014 OIML R 49-1:2013, 4.2.7).....	19
7.9 Pressure loss test (ISO 4064-1:2014 OIML R 49-1:2013, 6.5).....	21
7.10 Flow disturbance tests (ISO 4064-1:2014 OIML R 49-1:2013, 6.3.4).....	25
7.11 Durability tests (ISO 4064-1:2014 OIML R 49-1:2013, 7.2.6).....	26
7.12 Magnetic field testing.....	31
7.13 Tests on ancillary devices of a water meter.....	31
7.14 Environmental testing.....	32
8 Performance tests related to influence factors and disturbances	32
8.1 General requirements (ISO 4064-1:2014 OIML R 49-1:2013, A.1).....	32
8.2 Dry heat (non-condensing) (ISO 4064-1:2014 OIML R 49-1:2013, A.5).....	36
8.3 Cold (ISO 4064-1:2014 OIML R 49-1:2013, A.5).....	37
8.4 Damp heat, cyclic (condensing) (ISO 4064-1:2014 OIML R 49-1:2013, A.5).....	38
8.5 Power supply variation (ISO 4064-1:2014 OIML R 49-1:2013, A.5).....	39
8.6 Vibration (random) (ISO 4064-1:2014 OIML R 49-1:2013, A.5).....	42
8.7 Mechanical shock (ISO 4064-1:2014 OIML R 49-1:2013, A.5).....	43
8.8 AC mains voltage dips, short interruptions and voltage variations (ISO 4064-1:2014 OIML R 49-1:2013, A.5).....	44
8.9 Bursts on signal lines (ISO 4064-1:2014 OIML R 49-1:2013, A.5).....	45
8.10 Bursts (transients) on AC and DC mains (ISO 4064-1:2014 OIML R 49-1:2013, A.5).....	47
8.11 Electrostatic discharge (ISO 4064-1:2014 OIML R 49-1:2013, A.5).....	48
8.12 Radiated electromagnetic fields (ISO 4064-1:2014 OIML R 49-1:2013, A.5).....	49
8.13 Conducted electromagnetic fields (ISO 4064-1:2014 OIML R 49-1:2013, A.5).....	51
8.14 Surges on signal, data and control lines (ISO 4064-1:2014 OIML R 49-1:2013, A.5).....	53
8.15 Surges on AC and DC mains power lines (ISO 4064-1:2014 OIML R 49-1:2013, A.5).....	54
8.16 Static magnetic field (ISO 4064-1:2014 OIML R 49-1:2013, 7.2.8).....	55
8.17 Absence of flow test.....	56
9 Test program for type evaluation	57
9.1 Number of samples required.....	57
9.2 Performance test applicable to all water meters.....	57
9.3 Performance tests applicable to electronic water meters, mechanical water meters fitted with electronic devices, and their separable parts.....	58

9.4	Type evaluation of separable parts of a water meter	58
9.5	Families of water meters	59
10	Tests for initial verification	59
10.1	Initial verification of complete and combined water meters	59
10.2	Initial verification of separable parts of a water meter	60
11	Presentation of results	61
11.1	Object of the reports	61
11.2	Identification and test data to be included in records	61
Annex A (normative) Type examination and testing of checking facilities of electronic devices		63
Annex B (normative) Calculating the relative error (of indication) of a water meter		69
Annex C (normative) Installation requirements for flow disturbance tests		75
Annex D (normative) Type evaluation of a family of water meters		77
Annex E (informative) Examples of methods and components used for testing concentric water meters		79
Annex F (informative) Determining the density of water		82
Annex G (informative) Maximum uncertainties in the measurement of influence factors and disturbances		84
Annex H (informative) Pressure loss test pressure tappings, hole and slot details		87
Annex I (normative) Flow disturbers		90
Bibliography		101

Foreword

ISO (the International Organization for Standardization) is a worldwide federation of national standards bodies (ISO member bodies). The work of preparing International Standards is normally carried out through ISO technical committees. Each member body interested in a subject for which a technical committee has been established has the right to be represented on that committee. International organizations, governmental and non-governmental, in liaison with ISO, also take part in the work. ISO collaborates closely with the International Electrotechnical Commission (IEC) on all matters of electrotechnical standardization.

The procedures used to develop this document and those intended for its further maintenance are described in the ISO/IEC Directives, Part 1. In particular the different approval criteria needed for the different types of ISO documents should be noted. This document was drafted in accordance with the editorial rules of the ISO/IEC Directives, Part 2, www.iso.org/directives.

Attention is drawn to the possibility that some of the elements of this document may be the subject of patent rights. ISO shall not be held responsible for identifying any or all such patent rights. Details of any patent rights identified during the development of the document will be in the Introduction and/or on the ISO list of patent declarations received, www.iso.org/patents.

Any trade name used in this document is information given for the convenience of users and does not constitute an endorsement.

The committees responsible for this document are Technical Committee ISO/TC 30, *Measurement of fluid flow in closed conduits*, Subcommittee SC 7, *Volume methods including water meters* and OIML Technical Subcommittee TC 8/SC 5 *Water meters*.

This fourth edition of ISO 4064-2 cancels and replaces the third edition (ISO 4064-2:2005), which has been technically revised. Provisions of the third edition are addressed in ISO 4064-5:2014.

ISO 4064 consists of the following parts, under the general title *Water meters for cold potable water and hot water*:

- *Part 1: Metrological and technical requirements*
- *Part 2: Test methods*
- *Part 3: Test report format*
- *Part 4: Non-metrological requirements not covered in ISO 4064-1*
- *Part 5: Installation requirements*

This edition of ISO 4064-2 is identical with the corresponding edition of OIML R 49-2, which has been issued concurrently. OIML R 49-2 was approved for final publication by the International Committee of Legal Metrology at its 48th meeting in Ho Chi Minh City, Vietnam in October 2013 and will be submitted to the International Conference on Legal Metrology in 2016 for formal sanction.

Water meters for cold potable water and hot water —

Part 2: Test methods

1 Scope

This part of ISO 4064|OIML R 49 is applicable to the type evaluation and initial verification testing of water meters for cold potable water and hot water as defined in ISO 4064-1:2014|OIML R 49-1:2013. OIML Certificates of Conformity can be issued for water meters under the scope of the OIML Certificate System, provided that this part of ISO 4064|OIML R 49, ISO 4064-1:2014|OIML R 49-1:2013 and ISO 4064-3:2014|OIML R 49-3:2013 are used in accordance with the rules of the System.

This part of ISO 4064|OIML R 49 sets out details of the test programme, principles, equipment and procedures to be used for the type evaluation, and initial verification of a meter type.

The provisions of this part of ISO 4064|OIML R 49 also apply to ancillary devices, if required by national regulations.

The provisions include requirements for testing the complete water meter and for testing the measurement transducer (including the flow or volume sensor) and the calculator (including the indicating device) of a water meter as separate units.

2 Normative references

The following documents, in whole or in part, are normatively referenced in this document and are indispensable for its application. For dated references, only the edition cited applies. For undated references, the latest edition of the referenced document (including any amendments) applies.

ISO 4064-1:2014|OIML R 49-1:2013, *Water meters for cold potable water and hot water — Part 1: Metrological and technical requirements*

ISO 4064-3:2014|OIML R 49-3:2013, *Water meters for cold potable water and hot water — Part 3: Test report format*

ISO/IEC Guide 98-3:2008, *Uncertainty of measurement — Part 3: Guide to the expression of uncertainty in measurement (GUM:1995)*

IEC 60068-2-1, *Environmental testing — Part 2-1: Tests — Test A: Cold*

IEC 60068-2-2, *Environmental testing — Part 2-2: Tests — Test B: Dry heat*

IEC 60068-2-30, *Environmental testing — Part 2-30: Tests — Test Db: Damp heat, cyclic (12 h + 12 h cycle)*

IEC 60068-2-31, *Environmental testing — Part 2-31: Tests — Test Ec: Rough handling shocks, primarily for equipment-type specimens*

IEC 60068-2-47, *Environmental testing — Part 2-47: Tests — Mounting of specimens for vibration, impact and similar dynamic tests*

IEC 60068-2-64, *Environmental testing — Part 2-64: Tests — Test Fh: Vibration, broadband random and guidance*

IEC 60068-3-4, *Environmental testing — Part 3-4: Supporting documentation and guidance — Damp heat tests*

IEC 60654-2, *Operating conditions for industrial process measurement and control equipment — Part 2: Power*

IEC 61000-2-1, *Electromagnetic compatibility (EMC) — Part 2: Environment — Section 1: Description of the environment — Electromagnetic environment for low-frequency conducted disturbances and signaling in public power supply systems*

IEC 61000-2-2, *Electromagnetic compatibility (EMC) — Part 2-2: Environment — Compatibility levels for low-frequency conducted disturbances and signaling in public low-voltage power supply systems*

IEC 61000-4-1, *Electromagnetic compatibility (EMC) — Part 4-1: Testing and measurement techniques — Overview of IEC 61000-4 series*

IEC 61000-4-2, *Electromagnetic compatibility (EMC) — Part 4-2: Testing and measurement techniques — Electrostatic discharge immunity test*

IEC 61000-4-3, *Electromagnetic compatibility (EMC) — Part 4-3: Testing and measurement techniques — Radiated, radio frequency, electromagnetic field immunity test*

IEC 61000-4-4, *Electromagnetic compatibility (EMC) — Part 4-4: Testing and measurement techniques — Electrical fast transient/burst immunity test*

IEC 61000-4-5, *Electromagnetic compatibility (EMC) — Part 4-5: Testing and measurement techniques — Surge immunity test*

IEC 61000-4-6, *Electromagnetic compatibility (EMC) — Part 4-6: Testing and measurement techniques — Immunity to conducted disturbances, induced by radio-frequency fields*

IEC 61000-4-11, *Electromagnetic compatibility (EMC) — Part 4-11: Testing and measurement techniques — Voltage dips, short interruptions and voltage variations immunity tests*

IEC 61000-6-1, *Electromagnetic compatibility (EMC) — Part 6-1: Generic standards — Immunity for residential, commercial and light-industrial environments*

IEC 61000-6-2, *Electromagnetic compatibility (EMC) — Part 6-2: Generic standards — Immunity for industrial environments*

OIML D 11:2004, *General requirements for electronic measuring instruments*

OIML G 13, *Planning of metrology and testing laboratories*

3 Terms and definitions

For the purposes of this document, the terms and definitions given in ISO 4064-1:2014|OIML R 49-1:2013 apply.

4 Reference conditions

All applicable influence quantities, except for the influence quantity being tested, shall be held at the following values during type evaluation tests on a water meter. However, for influence factors and

disturbances for electronic water meters, it is permissible to use the reference conditions defined in the applicable IEC standard:

Flow rate:	$0,7 \times (Q_2 + Q_3) \pm 0,03 \times (Q_2 + Q_3)$
Water temperature:	T30, T50 is $20\text{ °C} \pm 5\text{ °C}$ T70 to T180 is $20\text{ °C} \pm 5\text{ °C}$ and $50\text{ °C} \pm 5\text{ °C}$ T30/70 to T30/180 is $50\text{ °C} \pm 5\text{ °C}$
Water pressure:	Within rated operating conditions (see ISO 4064-1:2014 OIML R 49-1:2013, 6.4)
Ambient temperature range:	15 °C to 25 °C
Ambient relative humidity range:	45 % to 75 %
Ambient atmospheric pressure range:	86 kPa to 106 kPa [0,86 bar to 1,06 bar]
Power supply voltage (mains AC):	Nominal voltage, $U_{\text{nom}} \pm 5\%$
Power supply frequency:	Nominal frequency, $f_{\text{nom}} \pm 2\%$
Power supply voltage (battery):	A voltage V in the range $U_{\text{bmin}} \leq V \leq U_{\text{bmax}}$

During each test, the temperature and relative humidity shall not vary by more than 5 °C or 10 %, respectively, within the reference range. The reference conditions are permitted to deviate from the defined tolerance values during the performance tests if evidence can be given to the body responsible for type approval that the type of meter under consideration is not affected by the deviation of the condition in question. The actual values of the deviating condition, however, shall be measured and documented as part of the performance test documentation.

5 Symbols, units and equations

Equations, symbols and their units, concerning the calculation of the error (of indication) of a water meter used in this part of ISO 4064|OIML R 49, are given in [Annex B](#).

6 External examination

6.1 General

During the external examination, all relevant values, dimensions, and observations shall be recorded.

NOTE 1 For presentation of the results of type examinations, see [Clause 11](#).

NOTE 2 The relevant subclauses of ISO 4064-1:2014|OIML R 49-1:2013 are shown in parentheses in the following.

6.2 Object of the examination

To verify that a water meter meets the requirements of ISO 4064-1:2014|OIML R 49-1:2013 with respect to the design of the indicating device, the marking of the meter and the application of protection devices.

6.3 Preparation

Linear measurements that have to be taken of a meter shall be made using traceable, calibrated measuring devices.

The actual or apparent dimensions of the scales of the indicating device shall be taken without removing the meter lens or disassembling the meter.

NOTE A travelling microscope (cathetometer) can be used to measure the width, spacing and height of the scale divisions and the height of the numerals.

6.4 Examination procedures

6.4.1 General

The following aspects of a meter design shall be examined on at least one meter from the sample.

Either the same meter sample may be used for all the external examinations or different meters from the samples submitted may be used for some of the examinations.

6.4.2 Marks and inscriptions (ISO 4064-1:2014|OIML R 49-1:2013, 6.6)

- a) Verify that a place is provided for affixing the verification mark which is visible without dismantling the water meter.
- b) Verify that the water meter is clearly and indelibly marked with the information presented in ISO 4064-1:2014|OIML R 49-1:2013, 6.6.2.
- c) Complete the section reference ISO 4064-1:2014|OIML R 49-1:2013, 6.6.1 and 6.6.2 (r) in ISO 4064-3:2014|OIML R 49-3:2013, 4.4.1.

6.4.3 Indicating device (ISO 4064-1:2014|OIML R 49-1:2013, 6.7)

6.4.3.1 Function (ISO 4064-1:2014|OIML R 49-1:2013, 6.7.1.1)

- a) Verify that the indicating device provides an easily read, reliable and unambiguous visual indication of the indicated volume.
- b) Verify that the indicating device includes visual means for testing and calibration.
- c) If the indicating device includes additional elements for testing and calibration by other methods, e.g. for automatic testing and calibration, record the type(s) of device.
- d) If the meter is a combination meter with two indicating devices, [6.4.3](#) applies to both indicating devices.
- e) Complete the section reference ISO 4064-1:2014|OIML R 49-1:2013, 6.7.1.1 in ISO 4064-3:2014|OIML R 49-3:2013, 4.4.1.

6.4.3.2 Unit of measurement, symbol, and its placement (ISO 4064-1:2014|OIML R 49-1:2013, 6.7.1.2)

- a) Verify that the indicated volume of water is expressed in cubic metres.
- b) Verify that the symbol m^3 appears on the dial or immediately adjacent to the numbered display.
- c) Complete the section reference ISO 4064-1:2014|OIML R 49-1:2013, 6.7.1.2 in ISO 4064-3:2014|OIML R 49-3:2013, 4.4.1.

6.4.3.3 Indicating range (ISO 4064-1:2014|OIML R 49-1:2013, 6.7.1.3)

- a) Verify that the indicating device is able to record the indicated volume in cubic metres given in ISO 4064-1:2014|OIML R 49-1:2013, Table 5 corresponding to the permanent flow rate Q_3 without passing through zero.

- b) Complete the section reference ISO 4064-1:2014|OIML R 49-1:2013, 6.7.1.3, in ISO 4064-3:2014|OIML R 49-3:2013, 4.4.1.

6.4.3.4 Colour coding for indicating devices (ISO 4064-1:2014|OIML R 49-1:2013, 6.7.1.4)

- a) Verify that either:
- 1) the colour black is used to indicate the cubic metre and its multiples; and
 - 2) the colour red is used to indicate sub-multiples of a cubic metre; and
 - 3) the colours are applied either to the pointers, indexes, numbers, wheels discs, dials or aperture frames;
- or other means of indicating the cubic metre are used in which there is no ambiguity in distinguishing between the primary indication and alternative displays, e.g. sub-multiples for verification and testing.
- b) Complete the section reference ISO 4064-1:2014|OIML R 49-1:2013, 6.7.1.4, in ISO 4064-3:2014|OIML R 49-3:2013, 4.4.1.

6.4.3.5 Types of indicating device (ISO 4064-1:2014|OIML R 49-1:2013, 6.7.2)

6.4.3.5.1 Type 1 — Analogue device (ISO 4064-1:2014|OIML R 49-1:2013, 6.7.2.1)

- a) If a type 1 indicating device has been used, verify that volume is indicated by:
- either continuous movement of one or more pointers moving relative to graduated scales;
 - or continuous movement of one or more circular scales or drums, each passing an index.
- b) Verify that the value expressed in cubic metres for each scale division is of the form 10^n , where n is a positive or a negative whole number or zero, thereby establishing a system of consecutive decades.
- c) Verify that each scale is either graduated in values expressed in cubic metres or accompanied by a multiplication factor ($\times 0,001$; $\times 0,01$; $\times 1$; $\times 10$; $\times 100$; $\times 1\ 000$, etc.).
- d) Verify that the rotational movements of the pointers or circular scales are clockwise.
- e) Verify that the linear movement of the pointers or scales is from left to right.
- f) Verify that the movement of the numbered roller indicators is upwards.
- g) Complete the section reference ISO 4064-1:2014|OIML R 49-1:2013, 6.7.2.1, in ISO 4064-3:2014|OIML R 49-3:2013, 4.4.1.

6.4.3.5.2 Type 2 — Digital device (ISO 4064-1:2014|OIML R 49-1:2013, 6.7.2.2)

- a) Verify that the indicated volume is given by a line of digits, appearing in one or more apertures.
- b) Verify that the advance of one digit is completed while the digit of the next immediately lower decade changes from 9 to 0.
- c) Verify that the actual or apparent height of the digits is at least 4 mm.
- d) For non-electronic devices:
- 1) verify that the movement of the numbered roller indicators (drums) is upwards;

- 2) if the lowest value decade has a continuous movement, verify that the aperture is large enough to permit a digit to be read without ambiguity.

For electronic devices:

- 3) verify that for non-permanent displays the volume can be displayed at any time for at least 10 s;
- 4) check the entire display visually in the following sequence:
 - i) for seven segment type verify that all the elements can be correctly displayed (e.g. an “eights” test),
 - ii) for seven segment type verify that all the elements can be blanked (a “blanks” test),
 - iii) for graphical displays use an equivalent test to verify that display faults cannot result in any digit being misinterpreted,
 - iv) verify that each step of the sequence lasts at least 1 s.
- e) Complete the section reference ISO 4064-1:2014|OIML R 49-1:2013, 6.7.2.2 in ISO 4064-3:2014|OIML R 49-3:2013, 4.4.1.

6.4.3.5.3 Type 3 — Combination of analogue and digital devices (ISO 4064-1:2014|OIML R 49-1:2013, 6.7.2.3)

- a) If the indicating device is a combination of type 1 and 2 devices, verify that the respective requirements of each apply (see [6.4.3.5.1](#) and [6.4.3.5.2](#)).
- b) Complete the section reference ISO 4064-1:2014|OIML R 49-1:2013, 6.7.2.3 in ISO 4064-3:2014|OIML R 49-3:2013, 4.4.1.

6.4.3.6 Verification devices — First element of an indicating device — Verification interval (ISO 4064-1:2014|OIML R 49-1:2013, 6.7.3)

6.4.3.6.1 General requirements (ISO 4064-1:2014|OIML R 49-1:2013, 6.7.3.1)

- a) Verify that the indicating device has the means for visual, non-ambiguous verification testing and calibration.
- b) Note whether the visual verification display has a continuous or a discontinuous movement.
- c) Note whether, in addition to the visual verification display, the indicating device includes provisions for rapid testing by the inclusion of complementary elements (e.g. star wheels or discs), providing signals through externally attached sensors. Note the relationship, stated by the manufacturer, between the visual indication of volume and the signals emitted by these complementary devices.
- d) Complete the section reference ISO 4064-1:2014|OIML R 49-1:2013, 6.7.3.1 in ISO 4064-3:2014|OIML R 49-3:2013, 4.4.1.

6.4.3.6.2 Visual verification display (ISO 4064-1:2014|OIML R 49-1:2013, 6.7.3.2)

6.4.3.6.2.1 Value of the verification scale interval (ISO 4064-1:2014|OIML R 49-1:2013, 6.7.3.2.1)

- a) Verify that the value of the verification scale interval, expressed in cubic metres, is of the form 1×10^n , or 2×10^n , or 5×10^n , where n is a positive or negative whole number, or zero.
- b) For analogue and digital indicating devices with continuous movement of the first element, verify that the verification scale interval is formed from the division into 2, 5 or 10 equal parts of the interval between two consecutive digits of the first element.

- c) For analogue and digital indicating devices with continuous movement of the first element, verify that numbering is not applied to the divisions between consecutive digits of the first element.
- d) For digital indicating devices with discontinuous movement of the first element, the verification scale interval is the interval between two consecutive digits or incremental movements of the first element.
- e) Complete the section reference ISO 4064-1:2014|OIML R 49-1:2013, 6.7.3.2.1 in ISO 4064-3:2014|OIML R 49-3:2013, 4.4.1.

6.4.3.6.2.2 Form of the verification scale (ISO 4064-1:2014|OIML R 49-1:2013, 6.7.3.2.2)

- a) If the indicating device has continuous movement of the first element, check that the apparent scale spacing is not less than 1 mm and not more than 5 mm.
- b) Verify that the scale consists of:
 - either lines of equal thickness not exceeding one-quarter of the scale spacing and differing only in length;
 - or contrasting bands of a constant width equal to the scale spacing.
- c) Verify that the apparent width of the pointer at its tip does not exceed one-quarter of the scale spacing.
- d) Verify that the apparent width of the pointer at its tip does not exceed 0,5 mm.
- e) Complete the section reference ISO 4064-1:2014|OIML R 49-1:2013, 6.7.3.2.2, in ISO 4064-3:2014|OIML R 49-3:2013, 4.4.1.

6.4.3.6.2.3 Resolution of the indicating device (ISO 4064-1:2014|OIML R 49-1:2013, 6.7.3.2.3)

- a) Note the value of the verification scale interval, δV m³
- b) Calculate the actual volume V_a in m³ passed during 1 h 30 min at the minimum flow rate Q_1 , from
 $V_a = Q_1 \times 1,5$
- c) Calculate the resolution error ε_r of the indicating device, expressed as a percentage, from:

- 1) for continuous movement of the first element:

$$\varepsilon_r = \frac{0,5\delta V + 0,5\delta V}{V_a} \times 100\%$$

$$= \frac{\delta V}{V_a} \times 100\%$$

- 2) For discontinuous movement of the first element:

$$\varepsilon_r = \frac{\delta V + \delta V}{V_a} \times 100\%$$

$$= \frac{2\delta V}{V_a} \times 100\%$$

- d) Verify that for accuracy class 1 meters, the value of the verification scale interval is small enough to ensure that the resolution error ε_r of the indicating device does not exceed 0,25 % of the actual volume required during 1 h 30 min at the minimum flow rate, Q_1 .

$$\varepsilon_r \leq 0,25\%$$

- e) Verify that for accuracy class 2 meters, the verification scale interval is small enough to ensure that the resolution error ε_r of the indicating device does not exceed 0,5 % of the actual volume required during 1 h 30 min at the minimum flow rate, Q_1 .

$$\varepsilon_r \leq 0,5 \%$$

- f) Complete the section reference ISO 4064-1:2014|OIML R 49-1:2013, 6.7.3.2.3 in ISO 4064-3:2014|OIML R 49-3:2013, 4.4.1.

When the display of the first element is continuous, an allowance shall be made for a maximum error in each reading of not more than half of the verification scale interval.

When the display of the first element is discontinuous, an allowance shall be made for a maximum error in each reading of not more than one digit of the verification scale.

6.4.4 Protection devices (ISO 4064-1:2014|OIML R 49-1:2013, 6.8)

- a) Verify that the water meter includes protection devices as specified in ISO 4064-1:2014|OIML R 49-1:2013, 6.8.
- b) Complete the section reference ISO 4064-1:2014|OIML R 49-1:2013, 6.8.1 and 6.8.2.3 in ISO 4064-3:2014|OIML R 49-3:2013, 4.4.1.

7 Performance tests for all water meters

7.1 General

During the performance tests, all relevant values, dimensions and observations shall be recorded.

NOTE 1 For presentation of the results of type evaluation tests see [Clause 11](#).

NOTE 2 The relevant sub-clauses of ISO 4064-1:2014|OIML R 49-1:2013 are shown in parentheses in the following.

7.2 Required conditions for all tests

7.2.1 Water quality

Water meter tests shall be carried out using water. The water shall be that of the public potable water supply or shall meet the same requirements.

The water shall not contain any substance which might damage the meter or adversely affect its operation. It shall not contain air bubbles.

If water is being recycled, measures shall be taken to prevent residual water in the meter from becoming harmful to human beings.

7.2.2 General rules concerning test installation and location

7.2.2.1 Freedom from spurious influences

Test rigs shall be so designed, constructed, and used, that the performance of the rig itself shall not contribute significantly to the test error. To this end, high standards of rig maintenance, plus adequate supports and fittings, are necessary to prevent vibration of the meter, the test rig, and its accessories.

The test rig environment shall be such that the reference conditions of the test are met (see [Clause 4](#)).

During the tests, the gauge pressure at the outlet of each water meter shall be at least 0,03 MPa (0,3 bar) and shall be sufficient to prevent cavitation.

It shall be possible to carry out test readings rapidly and easily.

7.2.2.2 Group testing of meters

Meters are tested either individually or in groups. In the latter case, the individual characteristics of the meters shall be precisely determined. The presence of any meter in the test rig shall not contribute significantly to the test error of any other meter.

7.2.2.3 Location

The environment chosen for meter tests shall be in accordance with the principles elaborated in OIML G 13 and shall be free from disturbing influences (e.g. ambient temperature, vibration).

7.3 Static pressure test (ISO 4064-1:2014|OIML R 49-1:2013, 4.2.10)

7.3.1 Object of the test

To verify that the water meter can withstand the specified hydraulic test pressure for the specified time without leakage or damage.

7.3.2 Preparation

- a) Install the meters in the test rig either singly or in groups.
- b) Bleed the test rig pipework and the water meters of air.
- c) Ensure that the test rig is free from leaks.
- d) Ensure that the supply pressure is free from pressure pulsations.

7.3.3 Test procedure

7.3.3.1 In-line meters

- a) Increase the hydraulic pressure to 1,6 times the maximum admissible pressure (MAP) of the meter and hold it for 15 min.
- b) Examine the meters for physical damage, for external leaks and for leaks into the indicating device.
- c) Increase the hydraulic pressure to twice the MAP and hold this pressure level for 1 min.
- d) Examine the meters for physical damage, for external leaks and for leaks into the indicating device.
- e) Complete the test report in ISO 4064-3:2014|OIML R 49-3:2013, 4.5.1.

Additional requirements:

- 1) Increase and decrease the pressure gradually without pressure surges.
- 2) Apply only the reference temperatures for this test.
- 3) The flow rate shall be zero during the test.

7.3.3.2 Concentric meters

The test procedure in [7.3.3.1](#) also applies to pressure testing of concentric water meters; however, the seals located at the concentric meter/manifold interface (see example in [Figure E.1](#)) shall also be tested

to ensure that undisclosed internal leaks between the inlet and outlet passages of the meter do not occur.

When the pressure test is carried out, the meter and manifold shall be tested together. Requirements for testing concentric meters may vary according to the design; therefore an example of a test method is shown in [Figures E.2](#) and [E.3](#).

7.3.4 Acceptance criteria

There shall be no leakage from the meter or leakage into the indicating device, or physical damage, resulting from any of the pressure tests specified in [7.3.3.1](#) and [7.3.3.2](#).

7.4 Determination of intrinsic errors (of indication) (ISO 4064-1:2014|OIML R 49-1:2013, 7.2.3)

7.4.1 Object of the test

To determine the intrinsic errors (of indication) of a water meter and the effects of the meter orientation on the error (of indication).

7.4.2 Preparation

7.4.2.1 Description of the test rig

The method specified here for determining the meter errors (of indication) is the so-called “collection” method, in which the quantity of water passed through a water meter is collected in one or more collecting vessels and the quantity determined volumetrically or by weighing. Other methods may be used, provided the requirements of [7.4.2.2.6.1](#) are met.

The checking of the errors (of indication) consists in comparing the volume indications given by the meter under reference conditions against a calibrated reference device.

For the purpose of these tests, at least one meter should be tested without its temporary ancillary devices attached (if any) unless the device is essential for the testing of the meter.

The test rig consists, typically, of:

- a) a water supply (non-pressurized tank, pressurized tank, pump, etc.);
- b) pipework;
- c) a calibrated reference device (calibrated volumetric tank, weighing system, reference meter, etc.);
- d) means for measuring the time of the test;
- e) devices for automating the tests (if required);
- f) means for measuring water temperature;
- g) means for measuring water pressure;
- h) means to determine density, if necessary;
- i) means to determine conductivity, if necessary.

7.4.2.2 Pipework

7.4.2.2.1 Description

Pipework shall include:

- a) a test section in which the meter(s) is (are) placed;
- b) means for establishing the desired flow rate;
- c) one or two isolating devices;
- d) means for determining the flow rate;

and if necessary:

- e) means for checking that the pipework is filled to a datum level before and after each test;
- f) one or more air bleeds;
- g) a non-return device;
- h) an air separator;
- i) a filter.

During the test, flow leakage, flow input and flow drainage shall not be permitted either between the meter(s) and the reference device or from the reference device.

7.4.2.2.2 Test section

The test section shall include, in addition to the meter(s):

- a) one or more pressure tapplings for the measurement of pressure, of which one pressure tapping is situated upstream of, and close to, the (first) meter;
- b) means for measuring the temperature of the water close to the entry to the (first) meter.

The presence of any pipe components or devices placed in or near the measuring section shall not cause cavitation or flow disturbances capable of altering the performance of the meters or causing errors (of indication).

7.4.2.2.3 Precautions to be taken during tests

- a) Check that the operation of the test rig is such that, during a test, the actual volume of water that flows through the meter(s) is equal to that measured by the reference device.
- b) Check that the pipe (e.g. the swan-neck in the outlet pipe) is filled to the same datum level at the beginning and at the end of the test.
- c) Bleed all air from the interconnecting pipework and the meter(s). The manufacturer may recommend a procedure that ensures that all air is bled from the meter.
- d) Take all precautions necessary to avoid the effects of vibration and shock.

7.4.2.2.4 Special arrangements for the installation of meters

7.4.2.2.4.1 Avoidance of erroneous measurements

The following reminder of the most frequent causes of erroneous measurements and the necessary precautions for the installation of water meters on the test bench is prompted by the need to achieve a test installation in which:

- a) the hydrodynamic flow characteristics cause no discernible difference to the meter functioning when compared with hydrodynamic flow characteristics which are undisturbed; and
- b) the expanded uncertainty of the method employed does not exceed the stipulated value (see [7.4.2.2.6.1](#)).

7.4.2.2.4.2 Need for straight lengths of pipe or a flow straightener

The accuracy of non-volumetric water meters can be affected by upstream disturbance caused, for example, by the presence of bends, tees, valves or pumps.

In order to counteract these effects:

- a) the meter shall be installed in accordance with the manufacturer's instructions;
- b) the connecting pipework shall have an internal diameter matched to the relevant meter connection; and
- c) if necessary, a flow straightener shall be installed upstream of the straight pipe length.

7.4.2.2.4.3 Common causes of flow disturbance

A flow can be subject to two types of disturbance: velocity-profile distortion and swirl, both of which may affect the errors of indication of a water meter.

Velocity-profile distortion is typically caused by an obstruction partially blocking the pipe, e.g. the presence of a partly closed valve or a misaligned flange joint. This can easily be eliminated by careful application of installation procedures.

Swirl can be caused by two or more bends in different planes or by a single bend in combination with an eccentric reducer or partially closed valve. This effect can be controlled either by ensuring an adequate length of straight pipe upstream of the water meter, or by installing a flow straightening device, or by a combination of the two. However, where possible, these types of pipework configurations should be avoided.

7.4.2.2.4.4 Volumetric water meters

Some types of water meter, e.g. volumetric water meters (i.e. involving measuring chambers with mobile walls), such as oscillating piston or nutating disc meters, are considered insensitive to upstream installation conditions; hence no special conditions are required.

7.4.2.2.4.5 Meters employing electromagnetic induction

Meters employing electromagnetic induction as a measuring principle may be affected by the conductivity of the test water.

The conductivity of the water used for testing this type of meter should be within the operational range of conductivity specified by the meter manufacturer.

7.4.2.2.4.6 Other measuring principles

Other types of meter may require flow conditioning when measuring the errors of indication and in such cases the manufacturer's recommended installation requirements shall be followed (see [7.10](#)).

These installation requirements should be reported in the type approval certificate for a water meter.

Concentric meters that are proven to be unaffected by manifold configuration (see [7.4.2.2.4.4](#)) may be tested and used with any suitable manifold arrangement.

7.4.2.2.5 Errors of test commencement and termination

7.4.2.2.5.1 General

Adequate precautions shall be taken to reduce the uncertainties resulting from operation of test rig components during the test.

Details of the precautions to be taken are given in [7.4.2.2.5.2](#) and [7.4.2.2.5.3](#) for two cases encountered in the "collection" method.

7.4.2.2.5.2 Tests with readings taken with the meter at rest

This method is generally known as the standing-start-and-finish method.

Flow is established by opening a valve, situated downstream of the meter, and it is stopped by closure of this valve. The meter is read when the registration is stationary.

Time is measured between the start of the opening movement of the valve and the close of the closing movement. While flow is beginning and during the period of running at the specified constant flow rate, the error (of indication) of the meter varies as a function of the changes in flow rate (the error curve).

While the flow is being stopped, the combination of the inertia of the moving parts of the meter and the rotational movement of the water inside the meter may cause an appreciable error to be introduced in certain types of meter and for certain test flow rates.

It has not been possible, in this case, to determine a simple empirical rule which lays down conditions so that this error may always be negligible.

In case of doubt, it is advisable:

- a) to increase the volume and duration of the test;
- b) to compare the results with those obtained by one or more other methods, and in particular the method specified in [7.4.2.2.5.3](#), which eliminates the causes of uncertainty given in the preceding.

For some types of electronic water meters with pulse outputs that are used for testing, the response of the meter to changes in flow rate may be such that valid pulses are emitted after closure of the valve. In this case, means shall be provided to count these additional pulses.

Where pulse outputs are used for testing meters, the correspondence of the volume indicated by the pulse count to the volume displayed on the indicating device shall be checked.

7.4.2.2.5.3 Tests with readings taken under stable flow conditions and diversion of flow

This method is generally known as the flying-start-and-finish method.

The measurement is carried out when flow conditions have stabilized.

A switch diverts the flow into a calibrated vessel at the beginning of the measurement and diverts it away at the end.

The meter is read while in motion.

The reading of the meter is synchronized with the movement of the flow switch.

The volume collected in the vessel is the actual volume passed.

The uncertainty introduced into the volume may be considered negligible if the times of motion of the flow switch in each direction are identical within 5 % and if this time is less than 1/50 of the total time of the test.

7.4.2.2.6 Calibrated reference device

7.4.2.2.6.1 Expanded uncertainty of the value of measured actual volume

When a test is conducted, the expanded uncertainty in the determination of the actual volume passing through a water meter shall not exceed one-fifth of the applicable maximum permissible error for type evaluation and one-third of the applicable maximum permissible error for initial verification.

NOTE The uncertainty of the measured actual volume does not include a contribution from the water meter.

The estimated uncertainty shall be made according to ISO/IEC Guide 98-3:2008 with a coverage factor, $k = 2$.

7.4.2.2.6.2 Minimum volume of the calibrated reference device

The minimum volume permitted depends on requirements determined by the test start and end effects (timing error), and the design of the indicating device (value of the verification scale interval).

7.4.2.2.7 Major factors affecting the measurement of errors (of indication)

7.4.2.2.7.1 General

Variations in the pressure, flow rate and temperature in the test rig, and uncertainties in the precision of measurement of these physical quantities, are the principal factors affecting the measurement of the errors (of indication) of a water meter.

7.4.2.2.7.2 Supply pressure

The supply pressure shall be maintained at a constant value throughout the test at the chosen flow rate.

When testing water meters which are designated $Q_3 \leq 16 \text{ m}^3/\text{h}$, at test flow rates $\leq 0,1 Q_3$, constancy of pressure at the inlet of the meter (or at the inlet of the first meter of a group being tested) is achieved if the test rig is supplied through a pipe from a constant head tank. This ensures an undisturbed flow.

Any other methods of supply shown not to cause pressure pulsations exceeding those of a constant head tank may be used (e.g. a pressurized tank).

For all other tests, the pressure upstream of the meter shall not vary by more than 10 %. The maximum uncertainty ($k = 2$) in the measurement of pressure shall be 5 % of the measured value.

The estimated uncertainty shall be made according to ISO/IEC Guide 98-3:2008 with a coverage factor, $k = 2$.

Pressure at the entrance to the meter shall not exceed the maximum admissible pressure for the meter.

7.4.2.2.7.3 Flow rate

The flow rate shall be maintained at a constant value throughout the test at the chosen value.

The relative variation in the flow rate during each test (not including starting and stopping) shall not exceed:

$\pm 2,5$ % from Q_1 to Q_2 (exclusive);

$\pm 5,0$ % from Q_2 (inclusive) to Q_4 .

The flow rate value is the actual volume passed during the test divided by the time.

This flow rate variation condition is acceptable if the relative pressure variation (in flow to free air) or the relative variation of pressure loss (in closed circuits) does not exceed:

± 5 % from Q_1 to Q_2 (exclusive);

± 10 % from Q_2 (inclusive) to Q_4 .

7.4.2.2.7.4 Temperature

During a test, the temperature of the water shall not change by more than 5 °C.

The maximum uncertainty in the measurement of temperature shall not exceed 1 °C.

7.4.2.2.7.5 Orientation of water meter(s)

- a) If the meters are marked "H", mount the connecting pipework with the flow axis in the horizontal plane during the test (indicating device positioned on top).
- b) If the meters are marked "V", mount the connecting pipework with the flow axis in the vertical plane during the test:
 - 1) at least one meter from the sample shall be mounted with the flow axis vertical, with flow direction from bottom to top;
 - 2) at least one meter from the sample shall be mounted with the flow axis vertical, with flow direction from top to bottom;
- c) If the meters are not marked "H" or "V":
 - 1) at least one meter from the sample shall be mounted with the flow axis vertical, with flow direction from bottom to top;
 - 2) at least one meter from the sample shall be mounted with the flow axis vertical, with flow direction from top to bottom;
 - 3) at least one meter from the sample shall be mounted with the flow axis at an intermediate angle to the vertical and horizontal (chosen at the discretion of the body responsible for type approval);
 - 4) the remaining meters from the sample shall be mounted with the flow axis horizontal.
- d) Where the meters have an indicating device which is integral with the body of the meter, at least one of the horizontally mounted meters shall be oriented with the indicating device positioned at the side and the remaining meters shall be oriented with the indicating device positioned at the top.
- e) The tolerance on the position of the flow axis for all meters, whether horizontal, vertical or at an intermediate angle, shall be $\pm 5^\circ$.

Where fewer than four meters are presented to test, supplementary meters shall be taken from the basis population or the same meter shall be tested in different positions.

7.4.3 Combination meters

7.4.3.1 General

For a combination meter, the test method specified in [7.4.2.2.5.3](#), in which readings of the combination meter are taken at an established flow rate, ensures that the change-over device is functioning correctly for both increasing and decreasing flow rates. The test method specified in [7.4.2.2.5.2](#), in which readings of the meter are taken at rest, should not be used for this test as it does not allow the determination of the error (of indication) after regulating the test flow rate for decreasing flow rates for combination meters.

7.4.3.2 Test method for the determination of change-over flow rates (ISO 4064-1:2014|OIML R 49-1:2013, 7.2.3)

- a) Starting from a flow rate that is less than the change-over flow rate Q_{x2} , the flow rate is increased in successive steps of 5 % of the assumed value of Q_{x2} until flow rate Q_{x2} is achieved as defined in ISO 4064-1:2014|OIML R 49-1:2013, 3.3.6. The value of Q_{x2} is taken as the average of the values of indicated flow rate just before and just after change-over occurs.
- b) Starting from a flow rate that is greater than the change-over flow rate Q_{x1} , the flow rate is decreased in successive steps of 5 % of the assumed value of Q_{x1} until flow rate Q_{x1} is achieved as defined in ISO 4064-1:2014|OIML R 49-1:2013, 3.3.6. The value of Q_{x1} is taken as the average of the values of indicated flow rate just before and just after change-over occurs.
- c) Complete the test report in ISO 4064-3:2014|OIML R 49-3:2013, 4.5.2.

7.4.4 Test procedure

- a) Determine the intrinsic errors (of indication) of a water meter (in the measurement of the actual volume), for at least the following flow rates, the error at each flow rate being measured three times for 1), 2) and 5) and twice for the other flow rate ranges:
 - 1) Q_1 to $1,1Q_1$;
 - 2) Q_2 to $1,1Q_2$;
 - 3) $0,33 \times (Q_2 + Q_3)$ to $0,37 \times (Q_2 + Q_3)$;
 - 4) $0,67 \times (Q_2 + Q_3)$ to $0,74 \times (Q_2 + Q_3)$;
 - 5) $0,9Q_3$ to Q_3 ;
 - 6) $0,95Q_4$ to Q_4 ;and for combination meters:
 - 7) $0,85Q_{x1}$ to $0,95Q_{x1}$;
 - 8) $1,05Q_{x2}$ to $1,15Q_{x2}$.

NOTE Three points are always required for 1), 2) and 5), since it is at these flow rates that the repeatability is calculated.

- b) Test the water meter without its supplementary devices attached (if any).
- c) During a test, hold all other influence factors at reference conditions.
- d) Measure the errors (of indication) at other flow rates if the shape of the error curve indicates that the MPE may be exceeded.
- e) Calculate the relative error (of indication) for each flow rate in accordance with [Annex B](#).

- f) Complete the test report in ISO 4064-3:2014|OIML R 49-3:2013, 4.5.3.

Where the initial error curve is close to the maximum permissible error at a point other than at Q_1 , Q_2 or Q_3 , if this error is shown to be typical of the meter type, the body responsible for type approval may choose to define an additional flow rate for verification to be included in the type approval certificate.

It is recommended that the characteristic error curve for each water meter be plotted in terms of error against flow rate, so that the general performance of the water meter over its flow rate range can be evaluated.

The meter shall be tested at the reference temperature(s) given in [Clause 4](#). Where there are two reference temperatures, the tests shall be done at both temperatures. The MPE appropriate to the test temperature shall apply.

7.4.5 Acceptance criteria

- a) The relative errors (of indication) observed for each of the flow rates shall not exceed the maximum permissible errors given in ISO 4064-1:2014|OIML R 49-1:2013, 4.2.2 or 4.2.3. If the error observed on one or more meters is greater than the maximum permissible error at one flow rate only, then if only two results have been taken at that flow rate, the test at that flow rate shall be repeated; the test shall be declared satisfactory if two out of the three results at that flow rate lie within the maximum permissible error and the arithmetic mean of the results for the three tests at that flow rate lies within the maximum permissible error.
- b) If all the relative errors (of indication) of a water meter have the same sign, at least one of the errors shall not exceed one-half of the maximum permissible error. In all cases, this requirement shall be applied equitably with respect to the water supplier and the consumer (see also ISO 4064-1:2014|OIML R 49-1:2013, 4.3.3, paragraphs 3 and 8).
- c) The standard deviation for [7.4.4](#) a) 1), 2) and 5) shall not exceed one-third of the maximum permissible errors given in ISO 4064-1:2014|OIML R 49-1:2013, 4.2.2 or 4.2.3.

7.4.6 Interchange test on all types of cartridge meters and meters with exchangeable metrological modules (ISO 4064-1:2014|OIML R 49-1:2013, 7.2.7)

7.4.6.1 Object of the test

To confirm that the cartridge meters or meters with exchangeable metrological modules are insensitive to the influence of connection interfaces produced in series production.

7.4.6.2 Preparation

Two cartridge meters or exchangeable metrological modules and five connection interfaces are selected from the number of meters presented for approval.

Correct matching of a cartridge meter with a connection interface or an exchangeable metrological module with a connection interface, respectively, shall be checked prior to test. Moreover, the matching of the required marking on a cartridge meter or an exchangeable metrological module and a connection interface shall be checked. Adaptors are not permitted.

7.4.6.3 Test procedure

- a) Two cartridge meters or exchangeable metrological modules shall be tested in five connection interfaces of every compatible interface type, resulting in 10 accuracy curves for each type of compatible interface. The test flow rates shall be in accordance with the specifications in [7.4.4](#).
- b) During a test, hold all other influence factors at reference conditions.
- c) Calculate the relative error of indication for each flow rate in accordance with [Annex B](#).

d) Complete the test report in ISO 4064-3:2014|OIML R 49-3:2013, 4.5.4.

7.4.6.4 Acceptance criteria

- a) All accuracy curves shall be positioned within the MPE at all times.
- b) Error variation within the five tests shall be within 0,5 times MPE if standard connection interfaces are being used, within 1,0 times MPE if identical connection interfaces with identical connection dimensions to the standard interfaces but with different body shapes and flow patterns (valve meter and tap meter connection interfaces) are being used.

7.5 Water temperature test (ISO 4064-1:2014|OIML R 49-1:2013, 4.2.8)

7.5.1 Object of the test

To measure the effects of water temperature on the errors (of indication) of a meter.

7.5.2 Preparation

Apply the installation and operational requirements specified in [7.4.2](#).

7.5.3 Test procedure

Measure the error (of indication) of at least one meter at flow rate Q_2 with the inlet temperature held at $10\text{ °C} \pm 5\text{ °C}$ for temperature classes T30 to T180 and $30\text{ °C}^{+5\text{ °C}}_{0\text{ °C}}$ for temperature classes T30/70 to T30/180. All other influence factors are maintained at reference conditions.

Measure the error (of indication) of at least one meter at flow rate Q_2 with the inlet temperature held at the maximum admissible temperature (MAT) (ISO 4064-1:2014|OIML R 49-1:2013, Table 1) of the meter with a tolerance of $^{0\text{ °C}}_{-5\text{ °C}}$ and all other influence factors maintained at reference conditions.

- a) Calculate the relative error (of indication) for each inlet water temperature in accordance with [Annex B](#).
- b) Complete the test report in ISO 4064-3:2014|OIML R 49-3:2013, 4.5.5.

7.5.4 Acceptance criteria

The relative error (of indication) of the meter shall not exceed the applicable maximum permissible error.

7.6 Overload water temperature test (ISO 4064-1:2014|OIML R 49-1:2013, 7.2.5)

7.6.1 Object of the test

To verify that a meter's performance is not affected after exposure to an elevated, overload, water temperature, as required in ISO 4064-1:2014|OIML R 49-1:2013, 7.2.5.

This test only applies to meters with a MAT $\geq 50\text{ °C}$.

7.6.2 Preparation

Apply the installation and operational requirements specified in [7.4.2](#).

The test is to be performed on at least one meter.

7.6.3 Test procedure

- a) Expose the meter to a flow of water at the reference flow rate at a temperature of $\text{MAT} +10\text{ °C} \pm 2,5\text{ °C}$ for a period of 1 h after the meter has reached temperature stability.
- b) After recovery, measure the error (of indication) of the meter at flow rate Q_2 at the reference temperature.
- c) Calculate the relative error (of indication) in accordance with [Annex B](#).
- d) During the test, the reference conditions for all other influence quantities shall be maintained.
- e) Complete the test report in ISO 4064-3:2014|OIML R 49-3:2013, 4.5.5.

7.6.4 Acceptance criteria

- a) The meter functionality with regard to volume totalization shall remain unaffected.
- b) Additional functionality, as indicated by the manufacturer, shall remain unaffected.
- c) The error (of indication) of the meter shall not exceed the applicable MPE.

7.7 Water pressure test (ISO 4064-1:2014|OIML R 49-1:2013, 4.2.8)

7.7.1 Object of the test

To measure the effects of internal water pressure on the errors (of indication) of a meter.

7.7.2 Preparation

The installation and operational requirements specified in [7.4.2](#) shall apply.

7.7.3 Test procedure

Measure the error (of indication) of at least one meter at a flow rate of Q_2 with the inlet pressure held firstly at 0,03 MPa (0,3 bar) ($\begin{smallmatrix} +5\% \\ 0 \end{smallmatrix}$) and then at the maximum admissible pressure (MAP) ($\begin{smallmatrix} 0 \\ -10\% \end{smallmatrix}$).

- a) During each test, all other influence factors shall be maintained at reference conditions.
- b) Calculate the relative error (of indication) for each inlet water pressure in accordance with [Annex B](#).
- c) Complete the test report in ISO 4064-3:2014|OIML R 49-3:2013, 4.5.6.

7.7.4 Acceptance criteria

The relative errors (of indication) of the meter shall not exceed the applicable maximum permissible error.

7.8 Reverse flow test (ISO 4064-1:2014|OIML R 49-1:2013, 4.2.7)

7.8.1 Object of the test

To verify that a meter satisfies the requirement of ISO 4064-1:2014|OIML R 49-1:2013, 4.2.7 when reverse flow occurs.

A meter which is designed to measure reverse flow shall record the reverse flow volume accurately.

A meter which allows reverse flow, but which is not designed to measure it, shall be subjected to reverse flow. The errors shall subsequently be measured for forward flow, to check that there is no degradation in metrological performance caused by reverse flow.

A meter which is designed to prevent reverse flow (e.g. by means of an integral non-return valve) is subjected to the application of the maximum admissible pressure of the meter applied to the outlet connection and the measurement errors are subsequently measured for forward flow to ensure that there is no degradation in metrological performance caused by the pressure acting on the meter.

7.8.2 Preparation

The installation and operational requirements specified in [7.4.2](#) shall apply.

7.8.3 Test procedure

7.8.3.1 Meters designed to measure reverse flow

- a) Measure the error (of indication) of at least one meter at each of the following reverse flow rate ranges:
 - 1) Q_1 to $1,1Q_1$;
 - 2) Q_2 to $1,1Q_2$;
 - 3) $0,9Q_3$ to Q_3 .
- b) During each test, all other influence factors shall be maintained at reference conditions.
- c) Calculate the relative error (of indication) for each flow rate in accordance with [Annex B](#).
- d) Complete the test report in ISO 4064-3:2014|OIML R 49-3:2013, 4.5.7.2.
- e) In addition, the following tests shall be carried out with the application of reverse flow: pressure loss test ([7.9](#)), flow disturbance test ([7.10](#)), and durability test ([7.11](#)).

7.8.3.2 Meters not designed to measure reverse flow

- a) Subject the meter to a reverse flow of $0,9Q_3$ for 1 min.
- b) Measure the error (of indication) of at least one meter at the following forward flow rate ranges:
 - 1) Q_1 to $1,1Q_1$;
 - 2) Q_2 to $1,1Q_2$;
 - 3) $0,9Q_3$ to Q_3 .
- c) During each test, all other influence factors shall be maintained at reference conditions.
- d) Calculate the relative error (of indication) for each flow rate in accordance with [Annex B](#).
- e) Complete the test report in ISO 4064-3:2014|OIML R 49-3:2013, 4.5.7.3.

7.8.3.3 Meters which prevent reverse flow

- a) Meters which prevent reverse flow should be subjected to the maximum admissible pressure in the reverse flow direction for 1 min.
- b) Check that there is no significant leak past the valve.
- c) Measure the error (of indication) of at least one meter in the following forward flow rate ranges:
 - 1) Q_1 to $1,1Q_1$;
 - 2) Q_2 to $1,1Q_2$;

- 3) $0,9Q_3$ to Q_3 .
- d) During each test, all other influence factors shall be maintained at reference conditions.
- e) Calculate the relative error (of indication) for each flow rate in accordance with [Annex B](#).
- f) Complete the test report in ISO 4064-3:2014|OIML R 49-3:2013, 4.5.7.4.

7.8.4 Acceptance criteria

In the tests specified in [7.8.3.1](#), [7.8.3.2](#) and [7.8.3.3](#), the relative error (of indication) of the meter shall not exceed the applicable maximum permissible error.

7.9 Pressure loss test (ISO 4064-1:2014|OIML R 49-1:2013, 6.5)

7.9.1 Object of the test

To determine the maximum pressure loss through a water meter at any flow rate between Q_1 and Q_3 . To verify the maximum pressure loss is less than the maximum value acceptable for the pressure loss class of the meter (see ISO 4064-1:2014|OIML R 49-1:2013, Table 4). The pressure loss is defined as the pressure lost by the flowing fluid passing through the water meter under test, the water meter consisting of the meter, associated manifolds (for concentric meters) and connections, but excluding the pipework making up the test section. The test is required for forward flow and where appropriate for reverse flow (see [7.8.3.1](#)).

7.9.2 Equipment for pressure loss test

The equipment needed to carry out pressure loss tests consists of a measuring section of pipework containing the water meter under test and means for producing the stipulated constant flow rate through the meter. The same constant flow rate means as that employed for the measuring of the errors (of indication), specified in [7.4.2](#), is generally used for pressure-loss tests.

The upstream and downstream pipe lengths, with their end connections and pressure tapplings, plus the water meter under test, constitute the measuring section.

Pressure tapplings of similar design and dimensions shall be fitted to the inlet and outlet pipes of the measuring section. Pressure tapplings should be drilled at right angles to the pipe wall at the appropriate point. Tapplings should not be more than 4 mm or less than 2 mm in diameter. If the pipe diameter is less than or equal to 25 mm, the tapplings should be as close to 2 mm in diameter as possible. The diameter of the holes shall remain constant for a distance of not less than two tapping diameters before breaking into the pipe. The holes drilled through the pipe wall shall be free from burrs at the edges where they break through into the inlet and outlet pipe bores. Edges shall be sharp with neither a radius nor a chamfer.

A single pressure tapping may be provided and would be suitable for most tests. To provide more robust data, four or more pressure tapplings can be fitted around the pipe circumference in each measurement plane. These would be interconnected by means of tee-shaped connectors to give a true mean static pressure at the pipe cross-section. The design of a triple-tee arrangement is shown, for example, in ISO 5167-1:2003,^[11] Figure 1.

Guidance on the design of pressure tapplings is given in [Annex H](#).

The meter shall be installed in accordance with the manufacturer's instructions and the upstream and downstream connecting pipes in contact with the water meter shall have the same internal nominal diameter matched to the relevant meter connection. A difference in the diameter of the connecting pipes and that of the meter may result in an incorrect measurement.

The upstream and downstream pipes should be round and of smooth bore to minimize pressure loss in the pipe. The minimum dimensions for installing the tapplings are shown in [Figure 1](#). The upstream tapping should be positioned a distance of at least $10D$, where D is the internal pipe diameter, downstream

of the entrance to avoid errors being introduced by the entry connection and be positioned at least $5D$ upstream of the meter to avoid any errors introduced by the entry to the meter. The downstream tapping should be at least $10D$ downstream of the meter to allow pressure to recover following any restrictions within the meter and at least $5D$ upstream of the end of the test section to avoid any effect of downstream fittings.

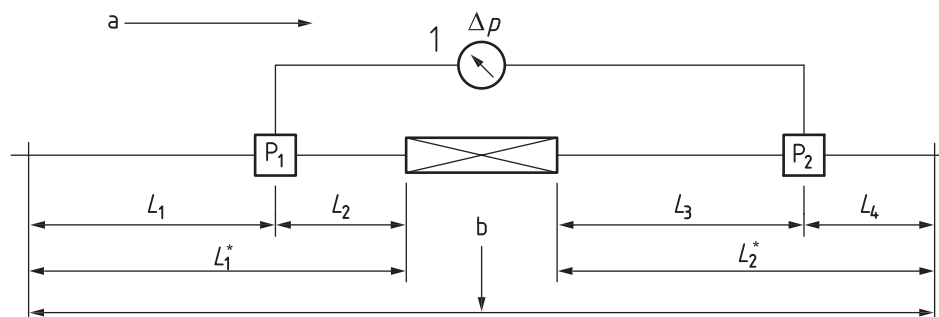

Key		
1	differential manometer	$L_1 \geq 10D$
2	water meter (plus manifold, for concentric meters)	$L_2 \geq 5D$
P_1, P_2	planes of the pressure tapings	$L_3 \geq 10D$
a	Flow direction.	$L_4 \geq 5D$
b	Measuring section.	where D is the internal diameter of the pipe-work

Figure 1 — Pressure loss test: layout of measuring section

These specifications give minimum lengths and longer lengths are acceptable. Each group of pressure tapings in the same plane shall be connected by a leak-free tube to one side of a differential pressure measuring device, e.g. a differential pressure transmitter or manometer. Provision shall be made for clearing air from the measuring device and connecting tubes. The maximum pressure loss shall be measured with a maximum expanded uncertainty of 5 % of the maximum pressure loss acceptable for the pressure loss class of the meter, with a coverage factor of $k = 2$.

7.9.3 Test procedure

7.9.3.1 Determination of installed pressure loss

The meter should be installed in the measuring section in the test facility. Flow is established and all air purged from the test section. Adequate back pressure should be ensured at the downstream pressure tapping at the maximum flow rate Q_3 . As a minimum, a static pressure downstream of the meter under test of 100 kPa (1 bar) is recommended to avoid cavitation or air release. All air should be removed from the pressure tapings and transmitter connecting pipes. The fluid should be allowed to stabilize at the required temperature. While monitoring the differential pressure, the flow should be varied between Q_1 and Q_3 . The flow rate showing the largest pressure loss, Q_t , should be noted along with the measured pressure loss and fluid temperature. Normally Q_t will be found to be equal to Q_3 . For combination meters, the maximum pressure loss often occurs just before Q_{x2} .

7.9.3.2 Determination of pressure loss attributable to test section

As some pressure is lost due to friction in the test section pipe between the pressure tapings, this should be determined and subtracted from the measured pressure loss across the meter. If the pipe diameter, roughness and length between the tapings are known, the pressure loss may be calculated from standard pressure loss formulae. It may, however, be more effective to measure the pressure loss across the pipes. The test section can be rearranged as shown in [Figure 2](#).

This is done by joining the upstream and downstream pipe faces together in the absence of the meter (carefully avoiding joint protrusion into the pipe bore or misalignment of the two faces), and measuring the pressure loss of the pipe measuring section for the specified flow rate.

NOTE The absence of the water meter will shorten the measuring section. If telescopic sections are not fitted on the test rig, the gap may be filled by inserting downstream of the measuring section either a temporary pipe of the same length as the water meter, or the water meter itself.

Measure the pressure loss for the pipe lengths at the previously determined flow rate Q_t .

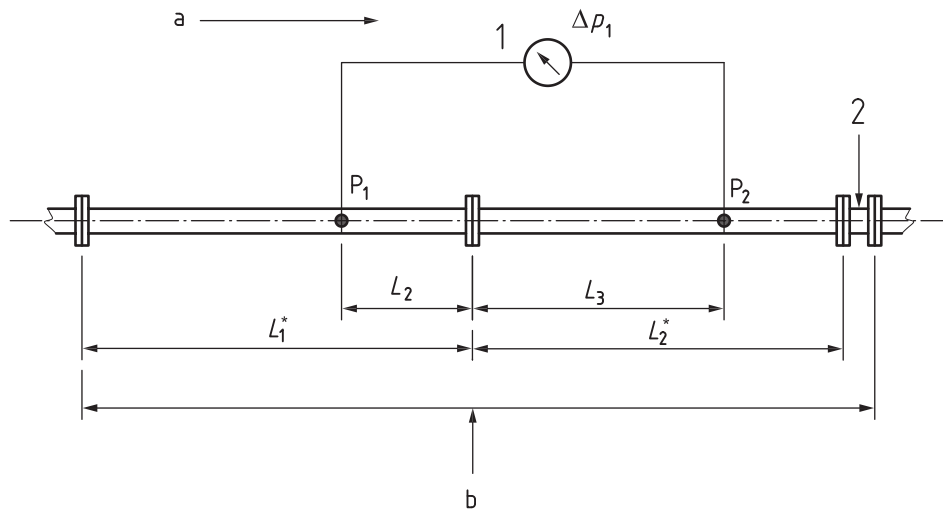

a) Pipe pressure loss

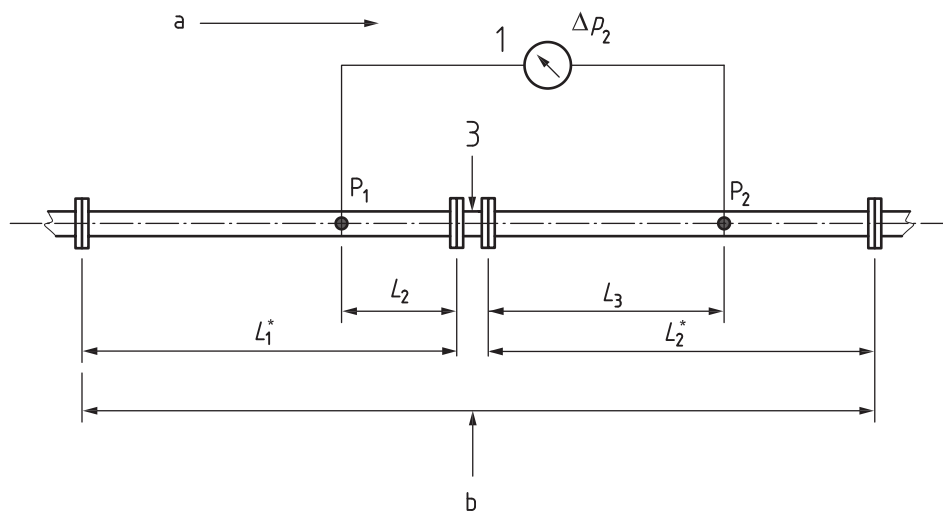

b) (Pipe and water meter) pressure loss

Key

1	differential manometer	3	water meter
2	water meter in downstream position (or temporary pipe)	P ₁ , P ₂	planes of the pressure tapplings
Δp_1	pressure loss of up- and downstream pipe lengths	$\Delta p_1 = (\Delta p_{L_2} + \Delta p_{L_3})$	
Δp_2	pressure loss of up- and downstream pipe lengths and water meter	$\Delta p_2 = (\Delta p_{L_2} + \Delta p_{L_3} + \Delta p_{\text{meter}})$	
	$\Delta p_2 - \Delta p_1 = (\Delta p_{L_2} + \Delta p_{L_3} + \Delta p_{\text{meter}}) - (\Delta p_{L_2} + \Delta p_{L_3}) = \Delta p_{\text{meter}}$		
a	Flow direction.	b	Measuring section.

Figure 2 — Pressure loss test

7.9.4 Calculation of the actual Δp of a water meter

Calculate the pressure loss, Δp_t , of the water meter at Q_t by making the subtraction

$$\Delta p_t = \Delta p_{m+p} - \Delta p_p$$

where

Δp_{m+p} is the measured pressure loss at Q_t with the meter in place;

Δp_p is the pressure loss measured without the meter at Q_t .

If the measured flow rate either during the test or during the determination of the pipe pressure loss is not equal to the selected test flow rate, the measured pressure loss can be corrected to that expected at Q_t by reference to the square law formula as follows:

$$\Delta p_{Q_t} = \frac{Q_t^2}{Q_{\text{meas}}^2} \Delta p_{Q_{\text{meas}}}$$

where

Δp_{Q_t} is the calculated pressure loss at Q_t ;

$\Delta p_{Q_{\text{meas}}}$ is the measured pressure loss at a flow rate Q_{meas} .

If the pressure loss is being measured across a combination meter, this formula only applies if the condition of the changeover device is the same at a flow rate of Q_t as it was at the measured flow rate. Note that the pipe pressure loss and the meter and pipe pressure loss shall be corrected to the same flow rate before the meter pressure loss Δp_t is calculated.

Complete the test report in ISO 4064-3:2014|OIML R 49-3:2013, 4.5.8. Note the water temperature, Δp_t , and Q_t .

7.9.5 Acceptability criteria

The pressure loss of the meter shall not exceed the maximum value acceptable for the pressure loss class of the meter at any flow rate between Q_1 and Q_3 inclusive.

7.10 Flow disturbance tests (ISO 4064-1:2014|OIML R 49-1:2013, 6.3.4)

7.10.1 Object of the tests

To verify that a meter complies with the requirements of ISO 4064-1:2014|OIML R 49-1:2013, 6.3.4 for forward flow and where appropriate for reverse flow (see [7.8.3.1](#)).

NOTE 1 The effects on the error (of indication) of a water meter of the presence of specified, common types of disturbed flow upstream and downstream of the meter are measured.

NOTE 2 Types 1 and 2 flow disturbers are used in tests to create left-handed (sinistrorsal) and right-handed (dextrorsal) rotational velocity fields (swirl), respectively. The flow disturbance is of a type usually found downstream of two 90° bends directly connected at right angles. A Type 3 disturbance device creates an asymmetric velocity profile usually found downstream of a protruding pipe joint, single bend or a gate valve not fully opened.

7.10.2 Preparation

In addition to the installation and operational requirements specified in [7.4.2](#), the conditions specified in [7.10.3](#) shall be applied.

7.10.3 Test procedure

- a) Using the flow disturbers of types 1, 2, and 3 specified in [Annex I](#), determine the error (of indication) of the meter at a flow rate between $0,9Q_3$ and Q_3 , for each of the installation conditions shown in [Annex C](#).
- b) During each test, all other influence factors shall be maintained at reference conditions.
- c) Complete the test report in ISO 4064-3:2014|OIML R 49-3:2013, 4.5.9.

Additional requirements follow.

- 1) For meters where the manufacturer has specified installation lengths of straight pipe of at least 15 times DN upstream and 5 times DN downstream of the meter, where DN is the nominal diameter, no external flow straighteners are allowed.
- 2) When a minimum straight pipe length of 5 times DN downstream of the meter is specified by the manufacturer, only tests 1, 3 and 5 shown in [Annex C](#) shall be performed.
- 3) Where meter installations with external flow straighteners are to be used, the manufacturer shall specify the straightener model, its technical characteristics and its position in the installation relative to the water meter.
- 4) Devices within the water meter having flow straightening functions shall not be considered to be a "straightener" in the context of these tests.
- 5) Some types of water meter which have been proven to be unaffected by flow disturbances upstream and downstream of the meter may be exempted from this test by the body responsible for type approval.
- 6) The straight lengths upstream and downstream of the meter depend on the flow profile sensitivity class of the meter and shall be in accordance with ISO 4064-1:2014|OIML R 49-1:2013, Tables 2 and 3, respectively.

7.10.4 Acceptance criteria

The relative error (of indication) of the meter shall not exceed the applicable maximum permissible error for any of the flow disturbance tests.

7.11 Durability tests (ISO 4064-1:2014|OIML R 49-1:2013, 7.2.6)

7.11.1 General

During durability tests, the rated operating conditions of the meter shall be met. Where a combination meter consists of individual meters that have been previously approved, only the discontinuous combination meters (additional test) ([Table 1](#)) is required. The test is required for forward flow and where appropriate for reverse flow (see [7.8.3.1](#)).

The orientation(s) of the meters under test shall be set with reference to the meter orientation(s) claimed by the manufacturer.

The same meters shall be submitted to the discontinuous and continuous tests.

7.11.2 Discontinuous flow test

7.11.2.1 Object of the test

To verify that a water meter is durable when subjected to cyclic flow conditions.

This test is applied only to meters with $Q_3 \leq 16 \text{ m}^3/\text{h}$ and combination meters.

The test consists of subjecting the meter to the specified number of starting and stopping flow rate cycles of short duration, the constant test flow rate phase of each cycle being kept at the prescribed flow rate throughout the duration of the test (see [7.11.2.3.2](#)). For the convenience of laboratories, the test can be divided up into periods of at least 6 h.

7.11.2.2 Preparation

7.11.2.2.1 Description of the installation

The installation consists of:

- a) a water supply (non-pressurized, pressurized tank; pump; etc.);
- b) pipework.

7.11.2.2.2 Pipework

The meters can be arranged in series or in parallel, or the two systems can be combined.

In addition to the meter(s), the piping system consists of:

- a) one flow-regulating device (per line of meters in series, if necessary);
- b) one or more isolating valves;
- c) a device for measuring the temperature of the water upstream of the meters;
- d) devices for checking the flow rate, the duration of cycles and the number of cycles;
- e) one flow-interrupting device for each line of meters in series;
- f) devices for measuring pressure at the inlet and outlet.

The various devices shall not cause cavitation phenomena or other types of parasitic wear of the meter(s).

7.11.2.2.3 Precautions to be taken

The meter(s) and connecting pipes shall be suitably bled of air.

The flow variation during the repeated opening and closing operations shall be progressive, so as to prevent water hammer.

7.11.2.2.4 Flow rate cycle

A complete cycle comprises the following four phases:

- a) a period from zero to the test flow rate;
- b) a period at constant test flow rate;
- c) a period from the test flow rate to zero;
- d) a period at zero flow rate.

7.11.2.3 Test procedure

7.11.2.3.1 General

- a) Before commencing the discontinuous durability test, measure the errors (of indication) of the meter(s) as specified in [7.4](#) and at the same flow rates as in [7.4.4](#).
- b) Mount the meters either singly or in groups in the test rig in the same orientations as those used in determination of the intrinsic errors (of indication) ([7.4.2.2.7.5](#)).
- c) During the tests, maintain the meters within their rated operating conditions and with the pressure downstream of the meters high enough to prevent cavitation in the meters.
- d) Adjust the flow rate to within the specified tolerances.
- e) Run the meter(s) at the conditions shown in [Table 1](#).
- f) Following the discontinuous durability test, measure the final errors (of indication) of the meters as specified in [7.4](#) and at the same flow rates as in [7.4.4](#).
- g) Calculate the final relative error (of indication) for each flow rate in accordance with [Annex B](#).
- h) For each flow rate, subtract the value of the intrinsic error (of indication) obtained at step a) from the error (of indication) obtained at step g).
- i) Complete the test report in ISO 4064-3:2014|OIML R 49-3:2013, 4.5.10.1 for meters with $Q_3 \leq 16 \text{ m}^3/\text{h}$ and ISO 4064-3:2014|OIML R 49-3:2013, 4.5.10.3 for combination meters.

7.11.2.3.2 Tolerance on flow rate

The relative variation of the flow values shall not exceed $\pm 10 \%$ outside the opening, closing, and stoppage periods. The meter(s) on test may be used to check the flow rate.

7.11.2.3.3 Tolerance on test timing

The tolerance on the specified duration of each phase of the flow cycle shall not exceed $\pm 10 \%$.

The tolerance on the total test duration shall not exceed $\pm 5 \%$.

7.11.2.3.4 Tolerance on the number of cycles

The number of cycles shall not be less than that stipulated, but shall not exceed this number by more than 1% .

7.11.2.3.5 Tolerance on discharged volume

The volume discharged throughout the test shall be equal to half the product of the specified test flow rate and the total theoretical duration of the test (operating periods plus transient and stoppage periods) with a tolerance of $\pm 5\%$.

This precision can be obtained by sufficiently frequent corrections of the instantaneous flows and operating periods.

7.11.2.3.6 Test readings

During the test, the following readings from the test rig shall be recorded at least once every 24 h period, or once for every shorter period if the test is so divided:

- line pressure upstream of the meter(s) under test;
- line pressure downstream of the meter(s) under test;
- line temperature upstream of the meter(s) under test;
- flow rate through the meter(s) under test;
- duration of the four phases of the cycle of the discontinuous flow test;
- number of cycles;
- indicated volumes of the meter(s) under test.

Table 1 — Durability tests

Temperature class	Permanent flow rate Q_3 m ³ /h	Test flow-rate	Test water temperature t_{test} °C ± 5 °C	Type of test	Number of interrupts	Time of pauses	Time of test at test flow rate	Duration of start-up and rundown
T30 and T50	≤ 16	Q_3	20	Discontinuous	100 000	15 s	15 s	0,15 [Q_3] ^a s with a minimum of 1 s
		Q_4	20	Continuous	—	—	100 h	—
	> 16	Q_3	20	Continuous	—	—	800 h	—
		Q_4	20	Continuous	—	—	200 h	—
All other temperature classes	≤ 16	Q_3	50	Discontinuous	100 000	15 s	15 s	0,15 [Q_3] ^a s with a minimum of 1 s
		Q_4	0,9 times MAT	Continuous	—	—	100 h	—
	> 16	Q_3	50	Continuous	—	—	800 h	—
		Q_4	0,9 times MAT	Continuous	—	—	200 h	—
Combination meters (additional test) ^b	> 16	$Q \geq 2 Q_{x2}$	20	Discontinuous	50 000	15 s	15 s	3 s to 6 s
Combination meters (where small meter has not been pre-approved)	> 16	$0,9Q_{x1}$	20	Continuous	—	—	200 h	—

^a [Q_3] Is the number equal to the value of Q_3 expressed in m³/h.

^b Where a combination meter consists of meters that have been previously approved, only the discontinuous test for combination meters (additional test) is required. The specified temperature for tests for combination meters assumes that the meter is of class T30 or T50. If it were of other classes, the reference temperature would be 50 °C.

7.11.2.4 Acceptance criteria after discontinuous durability test

7.11.2.4.1 For accuracy class 1 water meters

- a) The variation in the error curve shall not exceed 2 % for flow rates in the lower zone ($Q_1 \leq Q < Q_2$), and 1 % for flow rates in the upper zone ($Q_2 \leq Q \leq Q_4$). For the purpose of determining these requirements, the mean values of the errors (of indication) at each flow rate shall apply.
- b) The curves shall not exceed a maximum error limit of:
 - ±4 % for flow rates in the lower zone ($Q_1 \leq Q < Q_2$); and
 - ±1,5 % for flow rates in the upper zone ($Q_2 \leq Q \leq Q_4$) for T30 meters; or
 - ±2,5 % for flow rates in the upper zone ($Q_2 \leq Q \leq Q_4$) for meters other than T30.

7.11.2.4.2 For accuracy class 2 water meters

- a) The variation in the error curve shall not exceed 3 % for flow rates in the lower zone ($Q_1 \leq Q < Q_2$), or 1,5 % for flow rates in the upper zone ($Q_2 \leq Q \leq Q_4$). For the purpose of determining these requirements, the mean values of the errors (of indication) at each flow rate shall apply.
- b) The curves shall not exceed a maximum error limit of:
 - ±6 % for flow rates in the lower zone ($Q_1 \leq Q < Q_2$); and
 - ±2,5 % for flow rates in the upper zone ($Q_2 \leq Q \leq Q_4$) for T30 meters; or
 - ±3,5 % for flow rates in the upper zone ($Q_2 \leq Q \leq Q_4$) for meters other than T30.

7.11.3 Continuous flow test

7.11.3.1 Object of the test

To verify the durability of a water meter when subjected to continuous, permanent, and overload flow conditions.

The test consists of subjecting the meter to constant flow rate of Q_3 or Q_4 for a specified duration. In addition, where the small meter of a combination meter has not been pre-approved, the combination meter shall be subjected to a continuous flow test as shown in [Table 1](#). For the convenience of laboratories, the test can be divided up into periods of at least 6 h.

7.11.3.2 Preparation

7.11.3.2.1 Description of the installation

The installation consists of:

- a) a water supply (non-pressurized or pressurized tank, pump, etc.);
- b) pipework.

7.11.3.2.2 Pipework

In addition to the meter(s) to be tested, the pipework comprises:

- a) a flow-regulating device;
- b) one or more isolating valves;

- c) a device for measuring the water temperature at the meter inlet;
- d) means for checking the flow rate and duration of the test;
- e) devices for measuring pressure at the inlet and outlet.

The different devices shall not cause cavitation phenomena or other types of parasitic wear of the meter(s).

7.11.3.2.3 Precautions to be taken

The meter and connecting pipes shall be suitably bled of air.

7.11.3.3 Test procedure

7.11.3.3.1 General

- a) Before commencing the continuous durability test, measure the errors (of indication) of the meter(s) as specified in [7.4](#) and at the same flow rates as in [7.4.4](#).
- b) Mount the meter(s) either singly or in groups in the test rig in the same orientations as those used in the determination of the intrinsic error (of indication) tests ([7.4.2.2.7.5](#)).
- c) Run the meter(s) at the conditions shown in [Table 1](#).
- d) Throughout the durability tests, the meter(s) shall be held within their rated operating conditions and the pressure at the outlet of each meter shall be high enough to prevent cavitation.
- e) After the continuous durability test(s), measure the errors (of indication) of the meter(s) as specified in [7.4](#) and at the same flow rates.
- f) Calculate the relative error (of indication) for each flow rate in accordance with [Annex B](#).
- g) For each flow rate, subtract the error (of indication) obtained at step a) of [7.11.2.3.1](#) from the error (of indication) obtained at step f).
- h) Complete the test report in ISO 4064-3:2014|OIML R 49-3:2013, 4.5.10.2.

7.11.3.3.2 Tolerance on flow rate

The flow rate shall be kept constant throughout the test at a predetermined level.

The relative variation of the flow rate values during each test shall not exceed $\pm 10\%$ (except when starting and stopping).

7.11.3.3.3 Tolerance on test timing

The specified duration of the test is a minimum value.

7.11.3.3.4 Tolerance on discharged volume

The volume indicated at the end of the test shall not be less than that determined from the product of the specified test flow rate and the specified duration of the test.

To satisfy this condition, sufficiently frequent corrections to the flow rate shall be made. The water meter(s) on test may be used to check the flow rate.

7.11.3.3.5 Test readings

During the test, the following readings from the test rig shall be recorded at least once every 24 h period, or once for every shorter period if the test is so divided:

- a) water pressure upstream of the meter(s) under test;
- b) water pressure downstream of the meter(s) under test;
- c) water temperature upstream of the meter(s) under test;
- d) flow rate through the meter(s) under test;
- e) indicated volume of the meter(s) under test.

7.11.3.4 Acceptance criteria after continuous durability test

7.11.3.4.1 For accuracy class 1 water meters

- a) The variation in the error curve shall not exceed 2 % for flow rates in the lower zone ($Q_1 \leq Q < Q_2$), and 1 % for flow rates in the upper zone ($Q_2 \leq Q \leq Q_4$). For the purpose of determining these requirements, the mean values of the errors (of indication) at each flow rate shall apply.
- b) The curves shall not exceed a maximum error limit of:
 - ±4 % for flow rates in the lower zone ($Q_1 \leq Q < Q_2$); and
 - ±1,5 % for flow rates in the upper zone ($Q_2 \leq Q \leq Q_4$) for T30 meters; or
 - ±2,5 % for flow rates in the upper zone ($Q_2 \leq Q \leq Q_4$) for meters other than T30.

7.11.3.4.2 For accuracy class 2 water meters

- a) The variation in the error curve shall not exceed 3 % for flow rates in the lower zone ($Q_1 \leq Q < Q_2$), and 1,5 % for flow rates in the upper zone ($Q_2 \leq Q \leq Q_4$). For the purpose of determining these requirements, the mean values of the errors (of indication) at each flow rate shall apply.
- b) The curves shall not exceed a maximum error limit of:
 - ±6 % for flow rates in the lower zone ($Q_1 \leq Q < Q_2$); and
 - ±2,5 % for flow rates in the upper zone ($Q_2 \leq Q \leq Q_4$) for T30 meters; or
 - ±3,5 % for flow rates in the upper zone ($Q_2 \leq Q \leq Q_4$) for meters other than T30.

7.12 Magnetic field testing

All water meters where the mechanical components may be influenced by a static magnetic field (e.g. equipped with a magnetic coupling in the drive to the readout or with a magnet-driven pulse output) and all meters with electronic components shall be tested to show that they are able to withstand the influence of a static magnetic field.

This shall be tested according to the provisions of [8.16](#).

7.13 Tests on ancillary devices of a water meter

7.13.1 Object of the test

To verify that a meter complies with the requirements in ISO 4064-1:2014|OIML R 49-1:2013, 4.3.6.

The following two types of test are required.

- a) Where ancillary devices can be attached temporarily to the meter, e.g. for testing or data transmission purposes, the error of indication of the meter shall be measured with the ancillary device(s) fitted to ensure that the errors of indication do not exceed the MPEs.
- b) For permanently fitted and temporarily fitted ancillary devices, the indications of volume from the ancillary device/s shall be checked to ensure that the readings do not differ from those of the primary indication.

7.13.2 Preparation

- a) Apply the installation and operational requirements specified in [7.4.2](#).
- b) Temporary ancillary devices shall be fitted either by the manufacturer or in accordance with the manufacturer's instructions.
- c) Where the output from a ancillary device is an electric signal consisting of a pulse stream in which a single pulse corresponds to a finite volume, the pulses may be totalled on an electronic totalizer which, when connected, has no significant influence on the electrical signal.

7.13.3 Test procedure

- a) Determine the indication error of the meter with the temporary ancillary device fitted, in accordance with [7.4.4](#).
- b) Compare the readings from the temporarily or permanently fitted ancillary device with those of the primary indicating device.
- c) Complete the test report in ISO 4064-3:2014|OIML R 49-3:2013, 4.5.12.

7.13.4 Acceptance criteria

- a) The error (of indication) of the meter with the temporary ancillary device fitted shall not exceed the applicable maximum permissible error.
- b) For both permanent and temporarily fitted ancillary devices, the volume indications from the ancillary device(s) shall not differ from those of the visual display by more than the value of the verification scale interval.

7.14 Environmental testing

Depending on the meter technology and construction, there are appropriate levels of testing to meet environmental conditions. The relevant tests specified in [Clause 8](#) and ISO 4064-1:2014|OIML R 49-1:2013, [Annex A](#) shall be applied as appropriate. It is specified in [8.1.8](#) that these tests do not apply to meters of purely mechanical construction.

8 Performance tests related to influence factors and disturbances

8.1 General requirements (ISO 4064-1:2014|OIML R 49-1:2013, A.1)

8.1.1 Introduction

This clause defines the performance tests which are intended to verify that water meters perform and function as intended in a specified environment and under specified conditions. Each test indicates, where appropriate, the reference conditions for determining the intrinsic error.

These performance tests are additional to the tests specified in [Clause 7](#) and apply to complete meters, to separable parts of a water meter, and, if required, to ancillary devices. The tests are required depending on the environmental or electromagnetic class of meter as specified in [8.1.2](#) and [8.1.3](#) and the type of meter construction or design as specified in [8.1.8](#).

When the effect of one influence quantity is being evaluated, all other influence quantities are to be held at the reference conditions (see [Clause 4](#)).

The type evaluation tests specified in this clause may be carried out in parallel with the tests specified in [Clause 7](#), using examples of the same model of the water meter, or its separable parts.

8.1.2 Environmental classification

For each performance test, typical test conditions are indicated; they correspond to the mechanical and climatic environmental conditions to which water meters are exposed: see ISO 4064-1:2014|OIML R 49-1:2013, A.2.

8.1.3 Electromagnetic classification

Water meters with electronic devices are divided into two electromagnetic environmental classes: E1 for instruments operating in protected areas; and E2 for instruments operating in areas without any special protection. See ISO 4064-1:2014|OIML R 49-1:2013, A.3.

8.1.4 Reference conditions (ISO 4064-1:2014|OIML R 49-1:2013, 7.1)

Reference conditions are listed in [Clause 4](#).

These reference conditions should only be applied if no reference conditions are specified by a relevant regional or national standard designed to meet specific conditions. If specified by such a standard, then the criteria contained therein should be applied.

8.1.5 Test volumes for measuring error (of indication) of a water meter

Some influence quantities should have a constant effect on the error of indication of a water meter and not a proportional effect related to the measured volume.

In other tests, the effect of the influence quantity applied to a water meter is related to the measured volume. In these cases, in order to be able to compare results obtained in different laboratories, the test volume for measuring the error of indication of the meter shall correspond to that delivered in 1 min at the overload flow rate Q_4 .

However, some tests may require more than 1 min, in which case they shall be carried out in the shortest possible time, taking into consideration the measurement uncertainty.

8.1.6 Influence of the water temperature (ISO 4064-1:2014|OIML R 49-1:2013, A.5)

Dry heat, cold, and damp heat tests are concerned with measuring the effects of ambient air temperature on the performance of the meter. However, the presence of the measurement transducer, filled with water, may also influence heat dissipation in electronic components.

There are two options for the testing.

- a) The meter has water passing through it at the reference flow rate and the error (of indication) of the meter is measured with the electronic parts and the measurement transducer subjected to the reference conditions.
- b) A simulation of the measurement transducer is used for testing all electronic components. These simulated tests shall replicate the effects caused by the presence of water for those electronic devices which are normally attached to the flow sensor, and the reference conditions shall be applied during the tests.

Option a) is preferable.

8.1.7 Requirements for environmental tests

The following requirements are associated with the environmental tests and the relevant IEC standards to be applied are listed in the appropriate subclauses of this part of ISO 4064|OIML R 49:

- a) preconditioning of the equipment under test (EUT);
- b) any deviations in the procedure from the relevant IEC standard;
- c) initial measurements;
- d) state of the EUT during conditioning;
- e) severity levels, values of the influence factor and duration of exposure;
- f) measurements required and/or the loading during conditioning;
- g) recovery of the EUT;
- h) final measurements;
- i) acceptance criteria for the EUT passing a test.

Where no IEC standard exists for a specific test, the essential requirements for the test are given in this part of ISO 4064|OIML R 49.

8.1.8 Equipment under test (ISO 4064-1:2014|OIML R 49-1:2013, 7.2.12.3)

8.1.8.1 General

For the purpose of testing, the EUT shall be categorized as one of the cases, A to E, according to the technology specified in [8.1.8.2](#) to [8.1.8.5](#) and the following requirements shall apply:

- Case A No performance test (as mentioned in this subclause) is required.
- Case B The EUT is the complete meter or combined meter: the test shall be carried out with water flowing in the volume or flow sensor and the meter operating as designed.
- Case C The EUT is the measurement transducer (including the flow or volume sensor): the test shall be carried out with water flowing in the volume or flow sensor and the meter operating as designed.
- Case D The EUT is the electronic calculator (including the indicating device) or the ancillary device: the test shall be carried out with water flowing in the volume or flow sensor and the meter operating as designed.
- Case E The EUT is the electronic calculator (including the indicating device) or the ancillary device: the test may be carried out with simulated measurement signals without water in the volume or flow sensor.

The body responsible for type approval may apply an appropriate category, A to E, for approval testing of meters having technology which is not included in [8.1.8.2](#) to [8.1.8.5](#).

8.1.8.2 Positive displacement meters and turbine water meters

- | | |
|---|--------|
| a) The meter is not fitted with electronic devices: | Case A |
| b) The measurement transducer and the electronic calculator including the indicating device are in the same housing: | Case B |
| c) The measurement transducer is separate from the electronic calculator, but not fitted with electronic devices: | Case A |
| d) The measurement transducer is separate from the electronic calculator, and fitted with electronic devices: | Case C |
| e) The electronic calculator including the indicating device is separate from the measurement transducer and simulation of the measurement signals is not possible: | Case D |
| f) The electronic calculator including the indicating device is separate from the measurement transducer and simulation of the measurement signals is possible: | Case E |

8.1.8.3 Electromagnetic water meters

- | | |
|---|--------|
| a) The measurement transducer and the electronic calculator including the indicating device are in the same housing: | Case B |
| b) The flow sensor, consisting only of the pipe, the coil and the two meter electrodes, is without any additional electronic devices: | Case A |
| c) The measurement transducer including the flow sensor is separate from the electronic calculator and in one housing: | Case C |
| d) The electronic calculator including the indicating device is separate from the measurement transducer and simulation of the measurement signals is not possible: | Case D |

8.1.8.4 Ultrasonic water meters, Coriolis water meters, fluidic water meters

- | | |
|---|--------|
| a) The measurement transducer and the electronic calculator including the indicating device are in the same housing: | Case B |
| b) The measurement transducer is separate from the electronic calculator and fitted with electronic devices: | Case C |
| c) The electronic calculator including the indicating device is separate from the measurement transducer and simulation of the measurement signals is not possible: | Case D |

8.1.8.5 Ancillary devices

- | | |
|--|--------------|
| a) The ancillary device is part of the water meter, a part of the measurement transducer or part of the electronic calculator: | Cases A to E |
| b) The ancillary device is separate from the meter, but not fitted with electronic devices: | Case A |
| c) The ancillary device is separate from the meter, a simulation of the input signals is not possible: | Case D |
| d) The ancillary device is separate from the meter, a simulation of the input signals is possible: | Case E |

8.2 Dry heat (non-condensing) (ISO 4064-1:2014|OIML R 49-1:2013, A.5)

8.2.1 Object of the test

To verify that a water meter complies with the provisions of ISO 4064-1:2014|OIML R 49-1:2013, 4.2, during the application of high ambient temperatures as in ISO 4064-1:2014|OIML R 49-1:2013, Table A.1.

8.2.2 Preparation

Follow the test arrangements specified in IEC 60068-2-2.

Guidance on testing arrangements is given in IEC 60068-3-1[5] and IEC 60068-1[12].

8.2.3 Test procedure (in brief)

- a) No pre-conditioning is required.
- b) Measure the error (of indication) of the EUT at the reference flow rate and at the following test conditions:
 - 1) at the reference air temperature of $20\text{ °C} \pm 5\text{ °C}$, before conditioning the EUT;
 - 2) at an air temperature of $55\text{ °C} \pm 2\text{ °C}$, after the EUT has been stabilized at this temperature for a period of 2 h;
 - 3) at the reference air temperature of $20\text{ °C} \pm 5\text{ °C}$, after recovery of the EUT.
- c) Calculate the relative error (of indication) for each test condition in accordance with [Annex B](#).
- d) During the application of the test conditions, check that the EUT is functioning correctly.
- e) Complete the test report in ISO 4064-3:2014|OIML R 49-3:2013, 4.6.1.

Additional requirements follow.

- i) If the measurement transducer is included in the EUT, and it is necessary to have water in the flow sensor, the water temperature shall be held at the reference temperature.
- ii) When measuring the errors (of indication), the installation and operational conditions specified in [7.4.2](#) shall be followed and the reference conditions shall be applied unless otherwise specified. Test meters not marked "V" shall be mounted with the flow axis in the horizontal orientation. Meters with two reference temperatures are only tested at the lower reference temperature.

8.2.4 Acceptance criteria

During the application of the test conditions:

- a) all the functions of the EUT shall operate as designed;
- b) the relative error (of indication) of the EUT, at the test conditions, shall not exceed the maximum permissible error of the upper flow rate zone (see ISO 4064-1:2014|OIML R 49-1:2013, 4.2).

8.3 Cold (ISO 4064-1:2014|OIML R 49-1:2013, A.5)

8.3.1 Object of the test

To verify that a water meter complies with the provisions of ISO 4064-1:2014|OIML R 49-1:2013, 4.2, during the application of low ambient temperatures as in ISO 4064-1:2014|OIML R 49-1:2013, Table A.1.

8.3.2 Preparation

Follow the testing arrangements specified in IEC 60068-2-1.

Guidance on testing arrangements is given in IEC 60068-3-1[5] and IEC 60068-1[12].

8.3.3 Test procedure (in brief)

- a) Do not pre-condition the EUT.
- b) Measure the error (of indication) of the EUT at the reference flow rate and at the reference air temperature.
- c) Stabilize the air temperature at either $-25\text{ °C} \pm 3\text{ °C}$ (environmental classes O and M) or $+5\text{ °C} \pm 3\text{ °C}$ (environmental class B) for a period of 2 h.
- d) Measure the error (of indication) of the EUT at the reference flow rate at an air temperature of either $-25\text{ °C} \pm 3\text{ °C}$ (environmental classes O and M) or $+5\text{ °C} \pm 3\text{ °C}$ (environmental class B).
- e) After recovery of the EUT, measure the error (of indication) of the EUT at the reference flow rate and at the reference air temperature.
- f) Calculate the relative error (of indication) for each test condition in accordance with [Annex B](#).
- g) During the application of the test conditions, check that the EUT is functioning correctly.
- h) Complete the test report in ISO 4064-3:2014|OIML R 49-3:2013, 4.6.2.

Additional requirements follow.

- i) If it is necessary to have water in the flow sensor, the water temperature shall be held at the reference temperature.
- ii) When measuring the errors (of indication), the installation and operational conditions specified in [7.4.2](#) shall be followed and the reference conditions shall be applied unless otherwise specified. Test meters not marked "V" shall be mounted with the flow axis in the horizontal orientation. Meters with two reference temperatures are only tested at the lower reference temperature.

8.3.4 Acceptance criteria

During the application of the stabilized test conditions:

- a) all the functions of the EUT shall operate as designed; and

- b) the relative error (of indication) of the EUT, at the test conditions, shall not exceed the maximum permissible error of the upper flow rate zone (ISO 4064-1:2014|OIML R 49-1:2013, 4.2).

8.4 Damp heat, cyclic (condensing) (ISO 4064-1:2014|OIML R 49-1:2013, A.5)

8.4.1 Object of the test

To verify that a water meter complies with the provisions of ISO 4064-1:2014|OIML R 49-1:2013, 5.1.1), after applying conditions of high humidity, combined with cyclic temperature changes as in ISO 4064-1:2014|OIML R 49-1:2013, A.5.

8.4.2 Preparation

Follow the testing arrangements specified in IEC 60068-2-30.

Guidance on testing arrangements is given in IEC 60068-3-4.

8.4.3 Test procedure (in brief)

Follow the requirements for the performance of the test equipment, conditioning and recovery of the EUT, and exposure of the EUT to cyclic temperature changes under damp heat conditions specified in IEC 60068-2-30 and IEC 60068-3-4.

The test program consists of steps a) to g).

- a) Pre-condition the EUT.
- b) Expose the EUT to cyclic temperature variations between the lower temperature of $25\text{ °C} \pm 3\text{ °C}$ and the upper temperature of $55\text{ °C} \pm 2\text{ °C}$ (environmental classes O and M) or $40\text{ °C} \pm 2\text{ °C}$ (environmental class B). Maintain the relative humidity above 95 % during the temperature changes and during the phases at low temperature, and at $93\% \pm 3\%$ at the upper temperature phases. Condensation should occur on the EUT during the temperature rise.

The 24 h cycle consists of:

- 1) temperature rise over 3 h;
 - 2) temperature maintained at upper value until 12 h from the start of the cycle;
 - 3) temperature taken down to the lower value within 3 h to 6 h, the rate of fall during the first 1 h 30 min being such that the lower value would be reached in 3 h;
 - 4) temperature maintained at lower value until the 24 h cycle is completed
- c) Allow the EUT to recover.
- d) After recovery, check that the EUT is functioning correctly.
- e) Measure the error (of indication) of the EUT at the reference flow rate.
- f) Calculate the relative error (of indication) in accordance with [Annex B](#).
- g) Complete the test report in ISO 4064-3:2014|OIML R 49-3:2013, 4.6.3.

Additional requirements follow.

- i) The power supply to the EUT shall be switched off during steps a) to c).
- ii) The stabilizing period before and recovery after the cyclic exposure shall be such that all parts of the EUT are within 3 °C of their final temperature.

- iii) When measuring the error (of indication), the installation and operational conditions specified in [7.4.2](#) shall be followed and the reference conditions shall be applied unless otherwise specified. Test meters not marked “V” shall be mounted with the flow axis in the horizontal orientation. Meters with two reference temperatures are only tested at the lower reference temperature.

8.4.4 Acceptance criteria

After the application of the disturbance and recovery:

- a) all the functions of the EUT shall operate as designed;
- b) either the difference between any indication before the test and the indication after the test shall not exceed one-half of the maximum permissible error in the upper flow rate zone or the EUT shall detect and act upon a significant fault, in compliance with ISO 4064-1:2014|OIML R 49-1:2013, [Annex B](#).

8.5 Power supply variation (ISO 4064-1:2014|OIML R 49-1:2013, A.5)

8.5.1 General

Apply the flow chart in [Figure 3](#) to determine which tests are required.

8.5.2 Water meters powered by direct AC or by AC/DC converters (ISO 4064-1:2014|OIML R 49-1:2013, A.5)

8.5.2.1 Object of the test

To verify that electronic devices which operate at a nominal value of mains voltage, U_{nom} , at a nominal frequency, f_{nom} , comply with the provisions of ISO 4064-1:2014|OIML R 49-1:2013, 4.2, during static deviations of the AC (single-phase) mains power supply, applied in accordance with the requirements of ISO 4064-1:2014|OIML R 49-1:2013, A.5.

8.5.2.2 Preparation

Follow the testing arrangements specified in IEC 61000-4-11, IEC 61000-2-1, IEC 61000-2-2, IEC 61000-4-1, and IEC 60654-2.

8.5.2.3 Test procedure (in brief)

- a) Expose the EUT to power voltage variations and subsequently to power supply frequency variations, while the EUT is operating under reference conditions.
- b) Measure the error (of indication) of the EUT during the application of the upper mains voltage limit, $U_{nom} + 10\%$ (single voltage).
- c) Measure the error (of indication) of the EUT during the application of the upper mains frequency limit, $f_{nom} + 2\%$.
- d) Measure the error (of indication) of the EUT during the application of the lower mains voltage limit, $U_{nom} - 15\%$ (single voltage).
- e) Measure the error (of indication) of the EUT during the application of the lower mains frequency limit, $f_{nom} - 2\%$.
- f) Calculate the relative error (of indication) for each test condition in accordance with [Annex B](#).
- g) Check that the EUT is functioning correctly during the application of each power supply variation.
- h) Complete the test report in ISO 4064-3:2014|OIML R 49-3:2013, 4.6.4.2.

Additional requirements follow.

- i) During the measurement of the error (of indication), the EUT shall be subjected to the reference flow rate (ISO 4064-1:2014|OIML R 49-1:2013, 7.1).
- ii) When measuring the errors (of indication), the installation and operational conditions specified in 7.4.2 shall be followed and the reference conditions shall be applied unless otherwise specified. Test meters not marked “V” shall be mounted with the flow axis in the horizontal orientation. Meters with two reference temperatures are only tested at the lower reference temperature.

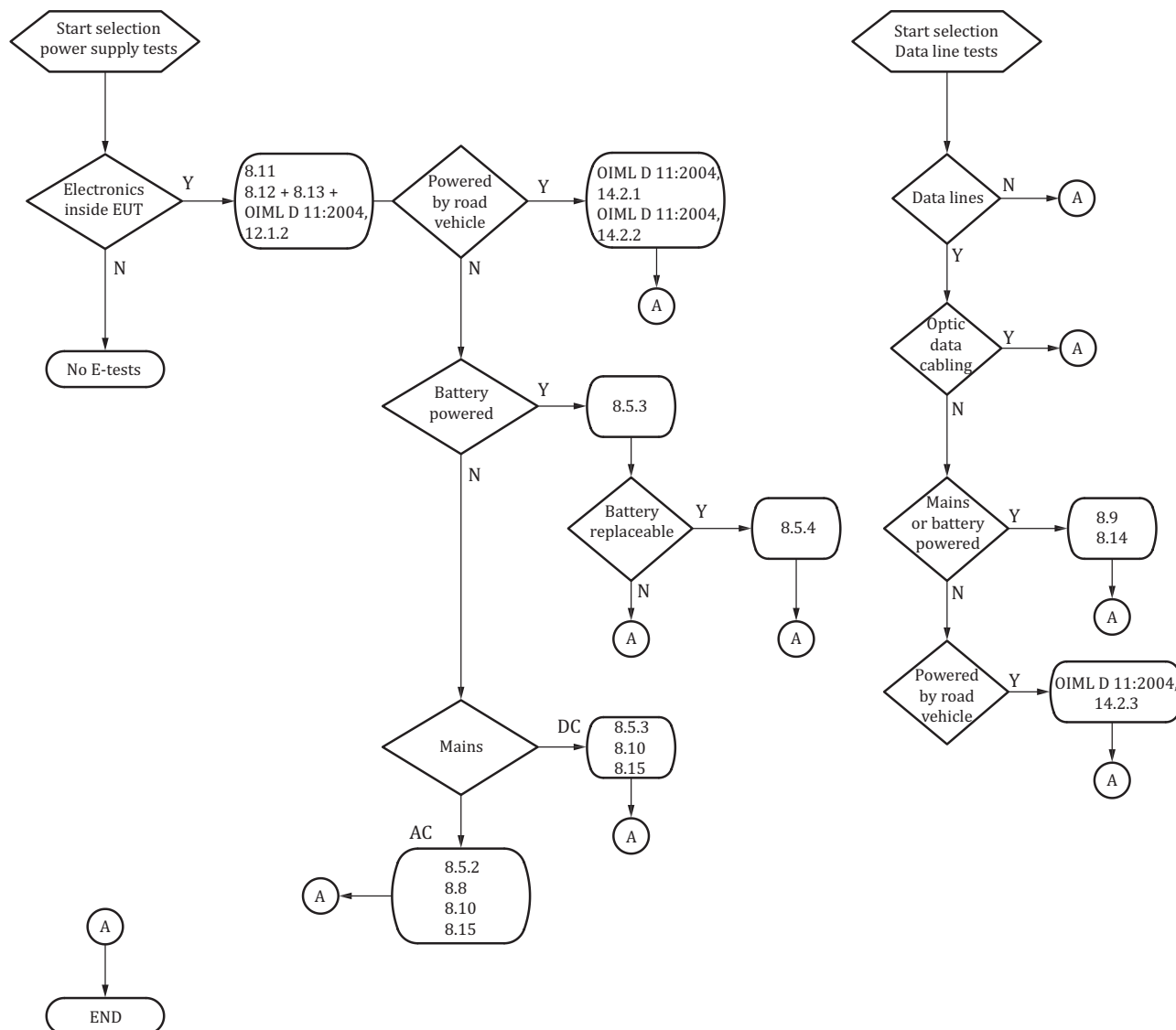

Figure 3 — Flow chart to determine the tests required in 8.5 and 8.8 to 8.15

8.5.2.4 Acceptance criteria

During the application of the influence factor:

- a) all the functions of the EUT shall operate as designed;
- b) the relative error of indication of the EUT, at the test conditions, shall not exceed the maximum permissible error of the upper flow rate zone (see ISO 4064-1:2014|OIML R 49-1:2013, 4.2).

8.5.3 Water meters powered by external DC voltage or by primary DC batteries (ISO 4064-1:2014|OIML R 49-1:2013, A.5)

8.5.3.1 Object of the test

To verify that a water meter complies with the provisions of ISO 4064-1:2014|OIML R 49-1:2013, 4.2 during static deviations of the DC power supply voltage, applied in accordance with the requirements of ISO 4064-1:2014|OIML R 49-1:2013, A.5.

8.5.3.2 Preparation

At the time of publication, no references to IEC standards for test methods can be given.

8.5.3.3 Test procedure

- a) Expose the EUT to power voltage variations, while the EUT is operating under reference conditions.
- b) Measure the error (of indication) of the EUT, during the application of the maximum operating voltage of the battery, as specified by the water meter supplier, for a battery or the DC voltage at which the EUT has been manufactured to automatically detect high-level conditions for an external DC supply.
- c) Measure the error (of indication) of the EUT, during the application of the minimum operating voltage of the battery, as specified by the water meter supplier, for a battery or the DC voltage at which the EUT has been manufactured to automatically detect low-level conditions for an external DC supply.
- d) Calculate the relative error (of indication) for each test condition in accordance with [Annex B](#).
- e) Check that EUT is functioning correctly during the application of each power supply variation.
- f) Complete the test report in ISO 4064-3:2014|OIML R 49-3:2013, 4.6.4.3.

Additional requirements follow.

- i) During the measurement of the error (of indication) the EUT shall be subjected to the reference flow rate.
- ii) When measuring the errors (of indication), the installation and operational conditions specified in [7.4.2](#) shall be followed and the reference conditions shall be applied unless otherwise specified. Test meters not marked "V" shall be mounted with the flow axis in the horizontal orientation. Meters with two reference temperatures are only tested at the lower reference temperature.

8.5.3.4 Acceptance criteria

During the application of the voltage variations:

- a) all the functions of the EUT shall operate as designed;
- b) the relative error (of indication) of the EUT at the test conditions shall not exceed the maximum permissible error of the upper flow rate zone (see ISO 4064-1:2014|OIML R 49-1:2013, 4.2).

8.5.4 Interruption in battery supply

8.5.4.1 Object of the test

To verify that a water meter complies with the requirements in ISO 4064-1:2014|OIML R 49-1:2013, 5.2.4.3, during replacement of the supply battery.

This test only applies to meters utilizing a replaceable battery supply.

8.5.4.2 Test procedure

- a) Ensure that the meter is operational.
- b) Remove the battery for a period of 1 h and then reconnect it.
- c) Interrogate the functions of the meter.
- d) Complete the section reference ISO 4064-1:2014|OIML R 49-1:2013, 5.2.4 in ISO 4064-3:2014|OIML R 49-3:2013, 4.4.2.2.

8.5.4.3 Acceptance criteria

After the application of the test conditions:

- a) all the functions of the EUT shall operate as designed;
- b) the value of the totalization or the stored values shall remain unchanged.

8.6 Vibration (random) (ISO 4064-1:2014|OIML R 49-1:2013, A.5)

8.6.1 Object of the test

To verify that a water meter complies with the provisions of ISO 4064-1:2014|OIML R 49-1:2013, 5.1.1, after the application of random vibrations (see ISO 4064-1:2014|OIML R 49-1:2013, Table A.1).

This test is applicable only to meters for mobile installations (environmental class M).

8.6.2 Preparation

Follow the testing arrangements specified in IEC 60068-2-64 and IEC 60068-2-47.

8.6.3 Test procedure (in brief)

- a) Mount the EUT on a rigid fixture by its normal mounting means, such that the gravitational force acts in the same direction as it would in normal use. However, if the gravitational effect is insignificant, and the meter is not marked "H" or "V", the EUT may be mounted in any position.
- b) Apply random vibrations over the frequency range of 10 Hz to 150 Hz to the EUT, in three, mutually perpendicular axes in turn, for a period of at least 2 min per axis.
- c) Allow the EUT a period for recovery.
- d) Examine the EUT for correct functioning.
- e) Measure the error (of indication) of the EUT at the reference flow rate.
- f) Calculate the relative error (of indication) in accordance with [Annex B](#).
- g) Complete the test report in ISO 4064-3:2014|OIML R 49-3:2013, 4.6.5.

Additional requirements follow.

- i) Where the flow sensor is included in the EUT, it shall not be filled with water during the application of the disturbance.
- ii) The power supply to the EUT is switched off during steps a), b) and c).
- iii) During the application of the vibrations the following conditions shall be met:

Total RMS level: 7 m/s²;

acceleration spectral density (ASD) level 10 Hz to 20 Hz: 1 m²/s³;

ASD level 20 Hz to 150 Hz: -3 dB/octave.

- iv) When measuring the errors (of indication) of the EUT, the installation and operational conditions specified in [7.4.2](#) shall be followed and the reference conditions shall be applied unless otherwise specified. Test meters not marked "V" shall be mounted with the flow axis in the horizontal orientation. Meters with two reference temperatures are only tested at the lower reference temperature.

8.6.4 Acceptance criteria

After the application of the vibrations and recovery:

- a) all functions of the EUT shall operate as designed;
- b) either the difference between any indication before the test and the indication after the test shall not exceed one-half of the maximum permissible error in the upper flow rate zone or the EUT shall detect and act upon a significant fault, in compliance with ISO 4064-1:2014|OIML R 49-1:2013, [Annex B](#).

8.7 Mechanical shock (ISO 4064-1:2014|OIML R 49-1:2013, A.5)

8.7.1 Object of the test

To verify that a water meter complies with the provisions of ISO 4064-1:2014|OIML R 49-1:2013, 5.1.1, after the application of the mechanical shock test (dropping on to face) as in ISO 4064-1:2014|OIML R 49-1:2013, Table A.1.

This test is applicable only to meters for mobile installations (environmental class M).

8.7.2 Preparation

Follow the testing arrangements specified in IEC 60068-2-31 and IEC 60068-2-47.

8.7.3 Test procedure (in brief)

- a) The EUT shall be placed on a rigid, level surface in its normal position of use and tilted towards one bottom edge until the opposite edge of the EUT is 50 mm above the rigid surface. However, the angle made by the bottom of the EUT and the test surface shall not exceed 30°.
- b) Allow the EUT to fall freely on to the test surface.
- c) Repeat steps a) and b) for each bottom edge.
- d) Allow the EUT a period for recovery.
- e) Examine the EUT for correct functioning.
- f) Measure the error (of indication) of the EUT at the reference flow rate.
- g) Calculate the relative error (of indication) in accordance with [Annex B](#).
- h) Complete the test report in ISO 4064-3:2014|OIML R 49-3:2013, 4.6.6.

Additional requirements follow.

- i) Where the flow sensor is part of the EUT, it shall not be filled with water during the application of the disturbance.
- ii) The power supply to the EUT shall be switched off during steps a), b), and c).

- iii) When measuring the errors (of indication) of the EUT, the installation and operational conditions specified in [7.4.2](#) shall be followed and the reference conditions shall be applied. Test meters not marked “V” shall be mounted with the flow axis in the horizontal orientation. Meters with two reference temperatures are only tested at the lower reference temperature.

8.7.4 Acceptance criteria

After the application of the disturbance and recovery:

- a) all the functions of the EUT shall operate as designed;
- b) either the difference between any indication before the test and the indication after the test shall not exceed one-half of the maximum permissible error in the upper flow rate zone or the EUT shall detect and act upon a significant fault, in compliance with ISO 4064-1:2014|OIML R 49-1:2013, [Annex B](#).

8.8 AC mains voltage dips, short interruptions and voltage variations (ISO 4064-1:2014|OIML R 49-1:2013, A.5)

8.8.1 Object of the test

To verify that a mains powered water meter complies with the provisions of ISO 4064-1:2014|OIML R 49-1:2013, 5.1.1, during the application of short-time, mains voltage interruptions and reductions as in ISO 4064-1:2014|OIML R 49-1:2013, Table A.1.

8.8.2 Preparation

Follow the testing arrangements specified in IEC 61000-4-11, IEC 61000-6-1, and IEC 61000-6-2.

8.8.3 Test procedure (in brief)

- a) Measure the error (of indication) of the EUT before applying power reduction test.
- b) Measure the error (of indication) of the EUT during the application of at least 10 voltage interruptions and 10 voltage reductions with an interval of at least 10 s.
- c) Calculate the relative error (of indication) for each test condition in accordance with [Annex B](#).
- d) Subtract the error (of indication) of the meter measured before applying the power reductions from that measured during the application of the power reductions.
- e) Examine the EUT for correct functioning.
- f) Complete the test report in ISO 4064-3:2014|OIML R 49-3:2013, 4.6.7.

Additional requirements follow.

- i) A test generator is used which is suitable to reduce the amplitude of the AC mains voltage for a defined period of time.
- ii) The performance of the test generator shall be verified before connecting the EUT.
- iii) Voltage interruptions and voltage reductions are applied throughout the period required to measure the error (of indication) of the EUT.
- iv) Voltage interruptions: the supply voltage is reduced from its nominal value, U_{nom} , to zero voltage, for the duration stated in [Table 2](#).

Table 2 — Voltage interruptions

Reduction to:	0 %
Duration:	250 cycles (50 Hz) 300 cycles (60 Hz)

- v) Voltage interruptions are applied in groups of 10.
- vi) Voltage reductions: the supply voltage is reduced from nominal voltage to the stated percentage of the nominal voltage for the duration stated in [Table 3](#).

Table 3 — Voltage reductions

Test	Test a	Test b	Test c
Reduction to:	0 %	0 %	70 %
Duration:	0,5 cycles	1 cycle	25 cycles (50 Hz) 30 cycles (60 Hz)

- vii) Voltage reductions are applied in groups of 10.
- viii) Each individual voltage interruption or reduction is initiated, terminated and repeated at zero crossings of the supply voltage.
- ix) The mains voltage interruptions and reductions are repeated at least 10 times with a time interval of at least 10 s between each group of interruptions and reductions. This sequence is repeated throughout the duration of the measurement of the error (of indication) of the EUT.
- x) During the measurement of the error (of indication) the EUT shall be subjected to the reference flow rate.
- xi) When measuring the errors (of indication), the installation and operational conditions specified in [7.4.2](#) shall be followed and the reference conditions shall be applied unless otherwise specified. Test meters not marked “V” shall be mounted with the flow axis in the horizontal orientation. Meters with two reference temperatures are only tested at the lower reference temperature.
- xii) When the EUT is designed to operate over a range of supply voltage, voltage reductions and interruptions shall be initiated from the mean voltage of the range.

8.8.4 Acceptance criteria

- a) After the application of the short-time power reductions all the functions of the EUT shall operate as designed.
- b) The difference between the relative error (of indication) obtained during the application of the short time power reductions and that obtained at the same flow rate before the test, under reference conditions, shall not exceed one-half of the maximum permissible error in the upper flow rate zone (see ISO 4064-1:2014|OIML R 49-1:2013, 4.2) or the EUT shall detect and act upon a significant fault in compliance with ISO 4064-1:2014|OIML R 49-1:2013, [Annex B](#).

8.9 Bursts on signal lines (ISO 4064-1:2014|OIML R 49-1:2013, A.5)

8.9.1 Object of the test

To verify that a water meter containing electronics and provided with input/output (I/O) and communication ports (including its external cables) complies with the provisions of ISO 4064-1:2014|OIML R 49-1:2013, 5.1.1, under conditions where electrical bursts are superimposed on I/O and communication port as in ISO 4064-1:2014|OIML R 49-1:2013, Table A.1.

8.9.2 Preparation

Follow the testing arrangements specified in IEC 61000-4-4 and IEC 61000-4-1.

8.9.3 Test procedure (in brief)

- a) Measure the error (of indication) of the EUT before applying the electrical bursts.
- b) Measure the error (of indication) of the EUT during the application of bursts of transient voltage spikes, of double exponential waveform.
- c) Calculate the relative error (of indication) for each test condition in accordance with [Annex B](#).
- d) Subtract the error (of indication) of the meter measured before applying the bursts from that measured during the application of the bursts.
- e) Examine the EUT for correct functioning.
- f) Complete the test report in ISO 4064-3:2014|OIML R 49-3:2013, 4.6.8.

Additional requirements follow.

- i) A burst generator shall be used with the performance characteristics as specified in the cited standard.
- ii) The characteristics of the generator shall be verified before connecting to the EUT.
- iii) Each spike shall have an amplitude (positive or negative) of 0,5 kV for environmental class E1 instruments or 1 kV for environmental class E2 instruments (see [8.1.3](#)), phased randomly, with a rise time of 5 ns and a half amplitude duration of 50 ns.
- iv) The burst length shall be 15 ms and the burst repetition rate shall be 5 kHz.
- v) The injection network on the mains shall contain blocking filters to prevent the burst energy from being dissipated in the mains.
- vi) For the coupling of the bursts into the I/O and communication lines, a capacitive coupling clamp as defined in the standard shall be used.
- vii) The duration of the test shall not be less than 1 min for each amplitude and polarity.
- viii) During the measurement of the error (of indication) the EUT shall be operated at the reference flow rate.
- ix) When measuring the error (of indication), the installation and operational conditions of the EUT, specified in [7.4.2](#), shall be followed and the reference conditions shall be applied unless otherwise specified. Test meters not marked "V" shall be mounted with the flow axis in the horizontal orientation. Meters with two reference temperatures are only tested at the lower reference temperature.

8.9.4 Acceptance criteria

- a) After the application of the disturbance, all the functions of the EUT shall operate as designed.
- b) The difference between the relative error of indication, obtained during the application of the bursts and that obtained at the same flow rate before the test, under reference conditions, shall not exceed one-half of the maximum permissible error in the upper flow rate zone. (see ISO 4064-1:2014|OIML R 49-1:2013, 4.2) or the EUT shall detect and act upon a significant fault in compliance with ISO 4064-1:2014|OIML R 49-1:2013, [Annex B](#).

8.10 Bursts (transients) on AC and DC mains (ISO 4064-1:2014|OIML R 49-1:2013, A.5)

8.10.1 Object of the test

To verify that the EUT containing electronics and powered by AC or DC mains voltage, complies with the provisions of ISO 4064-1:2014|OIML R 49-1:2013, 5.1.1, under conditions where electrical bursts are superimposed on the mains voltage as in ISO 4064-1:2014|OIML R 49-1:2013, Table A.1.

8.10.2 Preparation

Follow the testing arrangements specified in IEC 61000-4-4 and IEC 61000-4-1.

8.10.3 Test procedure (in brief)

- a) Measure the error (of indication) of the EUT before applying the electrical bursts.
- b) Measure the error (of indication) of the EUT during the application of bursts of transient voltage spikes, of double exponential waveform.
- c) Calculate the relative error (of indication) for each test condition in accordance with [Annex B](#).
- d) Subtract the error (of indication) of the meter measured before applying the bursts from that measured during the application of the bursts.
- e) Examine the EUT for correct functioning.
- f) Complete the test report in ISO 4064-3:2014|OIML R 49-3:2013, 4.6.9.

Additional requirements follow.

- i) A burst generator shall be used with the performance characteristics as specified in the cited standard.
- ii) The characteristics of the generator shall be verified before connecting to the EUT.
- iii) Each spike shall have an amplitude (positive or negative) of 1 kV for environmental class E1 instruments or 2 kV for environmental class E2 instruments (see [8.1.3](#)), phased randomly, with a rise time of 5 ns and a half amplitude duration of 50 ns.
- iv) The burst length shall be 15 ms and the burst repetition rate shall be 5 kHz.
- v) All bursts shall be applied asynchronously in common mode (asymmetrical voltage) during the measurement of the error (of indication) of the EUT.
- vi) The duration of the test shall not be less than 1 min for each amplitude and polarity.
- vii) During the measurement of the error (of indication) the EUT shall be operated at the reference flow rate.
- viii) When measuring the error (of indication), the installation and operational conditions of the EUT, specified in [7.4.2](#), shall be followed and the reference conditions shall be applied unless otherwise specified. Test meters not marked "V" shall be mounted with the flow axis in the horizontal orientation. Meters with two reference temperatures are only tested at the lower reference temperature.

8.10.4 Acceptance criteria

- a) After the application of the disturbance, all the functions of the EUT shall operate as designed.
- b) The difference between the relative error of indication, obtained during the application of the bursts and that obtained at the same flow rate before the test, under reference conditions,

shall not exceed one-half of the maximum permissible error in the upper flow rate zone (see ISO 4064-1:2014|OIML R 49-1:2013, 4.2) or the EUT shall detect and act upon a significant fault in compliance with ISO 4064-1:2014|OIML R 49-1:2013, [Annex B](#).

8.11 Electrostatic discharge (ISO 4064-1:2014|OIML R 49-1:2013, A.5)

8.11.1 Object of the test

To verify that a water meter complies with the provisions of ISO 4064-1:2014|OIML R 49-1:2013, 5.1.1, during the application of direct and indirect electrostatic discharges as in ISO 4064-1:2014|OIML R 49-1:2013, Table A.1.

8.11.2 Preparation

Follow the testing arrangements specified in IEC 61000-4-2.

8.11.3 Test procedure (in brief)

- a) Measure the error (of indication) of the EUT before applying the electrostatic discharges.
- b) Charge a 150 pF capacitor by means of a suitable DC voltage source, then discharge the capacitor through the EUT by connecting one terminal of the supporting chassis to earth and the other via a 330 Ω resistor to surfaces of the EUT which are normally accessible to the operator.

The following conditions shall be applied:

- 1) include the paint penetration method, if appropriate;
 - 2) for each contact discharge, a voltage of 6 kV shall be applied;
 - 3) for each air discharge, a voltage of 8 kV shall be applied;
 - 4) for direct discharges, the air discharge method shall be used where the manufacturer has declared a coating to be insulating;
 - 5) at each test location, at least 10 direct discharges shall be applied at intervals of at least 10 s between discharges, during the same measurement or simulated measurement;
 - 6) for indirect discharges, a total of 10 discharges shall be applied on the horizontal coupling plane and a total of 10 discharges for each of the various positions of the vertical coupling plane.
- c) Measure the error (of indication) of the EUT during the application of electrostatic discharges.
 - d) Calculate the relative error (of indication) for each test condition in accordance with [Annex B](#).
 - e) Determine if the significant fault has been exceeded by subtracting the error (of indication) of the meter measured before applying the electrostatic discharges from that measured after applying the electrostatic discharges.
 - f) Examine the EUT for correct functioning.
 - g) Complete the test report in ISO 4064-3:2014|OIML R 49-3:2013, 4.6.10.

Additional requirements follow.

- i) When measuring the error (of indication) the EUT shall be subjected to the reference flow rate.
- ii) When measuring the error (of indication), the installation and operational conditions specified in [7.4.2](#) shall be followed and the reference conditions shall be applied unless otherwise specified. Test meters not marked "V" shall be mounted with the flow axis in the horizontal orientation. Meters with two reference temperatures are only tested at the lower reference temperature.

- iii) In cases where a specific meter design is expected to be no less susceptible to disturbances at zero flow rate than if operated at the reference conditions for flow rate, the body responsible for type approval shall be free to choose a flow rate of zero during the electrostatic discharge test.
- iv) For EUT not equipped with an earth terminal, the EUT shall be fully discharged between discharges.
- v) Contact discharge is the preferred test method. Air discharges shall be used where contact discharge cannot be applied.

1) Direct application

In the contact discharge mode to be carried out on conductive surfaces, the electrode shall be in contact with the EUT.

In the air discharge mode on insulated surfaces, the electrode is moved towards the EUT and the discharge occurs by spark.

2) Indirect application

The discharges are applied in the contact mode to coupling planes mounted in the vicinity of the EUT.

8.11.4 Acceptance criteria

- a) After the application of the disturbance, all the functions of the EUT shall operate as designed.
- b) The difference between the relative error (of indication), obtained during the application of the electrostatic discharges and that obtained before the test, at the same flow rate, under reference conditions, shall not exceed one-half of the maximum permissible error in the upper flow rate zone (see ISO 4064-1:2014|OIML R 49-1:2013, 4.2) or the EUT shall detect and act upon a significant fault in compliance with ISO 4064-1:2014|OIML R 49-1:2013, [Annex B](#).
- c) For tests at zero flow rate, the water meter totalization shall not change by more than the value of the verification interval.

8.12 Radiated electromagnetic fields (ISO 4064-1:2014|OIML R 49-1:2013, A.5)

8.12.1 Object of the test

To verify that a water meter complies with the provisions of ISO 4064-1:2014|OIML R 49-1:2013, 5.1.1, during the application of radiated electromagnetic fields as in ISO 4064-1:2014|OIML R 49-1:2013, Table A.1.

8.12.2 Preparation

Follow the testing arrangements specified in IEC 61000-4-3. However, the test procedure specified in [8.12.3](#) is a modified procedure applicable to integrating instruments which totalize the measurand.

8.12.3 Test procedure (in brief)

- a) Measure the intrinsic error (of indication) of the EUT at reference conditions before applying the electromagnetic field.
- b) Apply the electromagnetic field in accordance with the requirements of i) to iv) in the following.
- c) Start a new measurement of the error (of indication) for the EUT.
- d) Step the carrier frequency until the next carrier frequency (see [Table 4](#)) is reached in accordance with requirements of iv) in the following.
- e) Stop the measurement of the error (of indication) for the EUT.

- f) Calculate the relative error (of indication) of the EUT in accordance with [Annex B](#).
- g) Calculate the fault by subtracting the intrinsic error (of indication) from step a) from the error (of indication) from step f). Determine whether the fault is a significant fault.
- h) Change the polarization of the antenna.
- i) Examine the EUT for correct functioning.
- j) Repeat steps b) to i).
- k) Complete the test report in ISO 4064-3:2014|OIML R 49-3:2013, 4.6.11.

Additional requirements follow.

- i) The EUT, and its external cables of at least 1,2 m length, shall be subjected to radiated electromagnetic fields at field strengths of either 3 V/m for environmental class E1 instruments or 10 V/m for environmental class E2 instruments (see [8.1.3](#)).

In accordance with IEC 61000-4-3, the frequency range for this radiated electromagnetic fields test is 26 MHz to 2 GHz, or 80 MHz to 2 GHz when the test for frequencies in the lower range in [8.13](#) is applicable.

- ii) The test is performed as several partial scans with a vertical antenna and several partial scans with a horizontal antenna. Recommended start and stop frequencies for each scan are listed in [Table 4](#).
- iii) Each intrinsic error (of indication) is determined by commencing at a start frequency and terminating when the next highest frequency of [Table 4](#) is reached.
- iv) During each scan, the frequency shall be changed in steps of 1 % of actual frequency, until the next frequency in [Table 4](#) is reached. The dwell time at each 1 % step shall be identical. However, the dwell time shall be equal for all carrier frequencies in the scan and shall be sufficient for the EUT to be exercised and able to respond at each frequency.
- v) The error (of indication) measurements shall be carried out with all of the scans listed in [Table 4](#).
- vi) When measuring the error (of indication), the EUT shall be subjected to the reference flow rate.
- vii) When measuring the error (of indication), the installation and operational conditions specified in [7.4.2](#) shall be followed and the reference conditions shall be applied unless otherwise specified. Test meters not marked "V" shall be mounted with the flow axis in the horizontal orientation. Meters with two reference temperatures are only tested at the lower reference temperature.
- viii) If a specific meter design is expected to be no less susceptible to radiated electromagnetic fields specified in [8.12](#) at zero flow rate than if operated at the reference conditions for flow rate, the body responsible for type approval shall be free to choose a flow rate of zero during the electromagnetic susceptibility test.

Table 4 — Start and stop carrier frequencies (Radiated electromagnetic fields)

MHz	MHz	MHz
26	160	600
40	180	700
60	200	800
80	250	934
100	350	1 000
120	400	1 400
144	435	2 000
150	500	
NOTE Break points are approximate.		

8.12.4 Acceptance criteria

- a) After the application of the disturbance, all the functions of the EUT shall operate as designed.
- b) The difference between the relative error (of indication) measured during the application of each carrier frequency band and that obtained at the same flow rate before the test, under reference conditions, shall not exceed one-half of the maximum permissible error in the upper flow rate zone (see ISO 4064-1:2014|OIML R 49-1:2013, 4.2) or the EUT shall detect and act upon a significant fault in compliance with ISO 4064-1:2014|OIML R 49-1:2013, [Annex B](#).
- c) During tests applied at zero flow rate, the water meter totalization shall not change by more than the value of the verification interval.

8.13 Conducted electromagnetic fields (ISO 4064-1:2014|OIML R 49-1:2013, A.5)

8.13.1 Object of the test

To verify compliance with the provisions of ISO 4064-1:2014|OIML R 49-1:2013, 5.1.1, during the application of conducted electromagnetic fields as in ISO 4064-1:2014|OIML R 49-1:2013, Table A.1.

8.13.2 Preparation

Follow the testing arrangements specified in IEC 61000-4-6. However, the test procedure specified in [8.13.3](#) is a modified procedure applicable to integrating instruments which totalize the measurand.

8.13.3 Test procedure (in brief)

- a) Measure the intrinsic error (of indication) of the EUT at reference conditions before applying the electromagnetic field.
- b) Apply the electromagnetic field in accordance with the requirements of i) to v) in the following.
- c) Start a new measurement of the error (of indication) for the EUT.
- d) Step the carrier frequency until the next carrier frequency (see [Table 5](#)) is reached in accordance with the requirements of v) in the following.
- e) Stop the measurement of the error (of indication) for the EUT.
- f) Calculate the relative error (of indication) of the EUT in accordance with [Annex B](#).
- g) Calculate the fault by subtracting the intrinsic error (of indication) from step a) from the error (of indication) from step f). Determine whether the fault is a significant fault.

- h) Examine the EUT for correct functioning.
- i) Complete the test report in ISO 4064-3:2014|OIML R 49-3:2013, 4.6.12.

Additional requirements follow.

- i) The EUT shall be subjected to conducted electromagnetic fields at RF amplitude of either 3 V (electromotive force, e.m.f.) for environmental class E1 instruments, or 10 V (e.m.f.) for environmental class E2 instruments (see [8.1.3](#)).
- ii) The frequency range for this conducted electromagnetic fields test is 0,15 MHz to 80 MHz in accordance with IEC 61000-4-6.
- iii) Recommended start and stop frequencies for each scan are listed in [Table 5](#).
- iv) Each intrinsic error (of indication) is determined by commencing at a start frequency and terminating when the next highest frequency of [Table 5](#) is reached.
- v) During each scan, the frequency shall be changed in steps of 1 % of actual frequency, until the next frequency in [Table 5](#) is reached. The dwell time at each 1 % step shall be identical. However, the dwell time shall be equal for all carrier frequencies in the scan and shall be sufficient for the EUT to be exercised and able to respond at each frequency.
- vi) The error (of indication) measurements shall be carried out with all of the scans listed in [Table 5](#).
- vii) When measuring the error (of indication), the EUT shall be subjected to the reference flow rate.
- viii) When measuring the error (of indication), the installation and operational conditions specified in [7.4.2](#) shall be followed and the reference conditions shall be applied unless otherwise specified. Test meters not marked “V” shall be mounted with the flow axis in the horizontal orientation. Meters with two reference temperatures are only tested at the lower reference temperature.
- ix) If a specific meter design is expected to be no less susceptible to conducted electromagnetic fields specified in [8.13](#) at zero flow rate than if operated at the reference conditions for flow rate, the body responsible for type approval shall be free to choose a flow rate of zero during the electromagnetic susceptibility test.

Table 5 — Start and stop carrier frequencies (Conducted electromagnetic fields)

MHz	MHz	MHz	MHz
0,15	1,1	7,5	50
0,30	2,2	14	80
0,57	3,9	30	
NOTE Break points are approximate.			

8.13.4 Acceptance criteria

- a) After the application of the disturbance, all the functions of the EUT shall operate as designed.
- b) The difference between the relative error (of indication) measured during the application of each carrier frequency band and that obtained at the same flow rate before the test, under reference conditions, shall not exceed one-half of the maximum permissible error in the upper flow rate zone (see ISO 4064-1:2014|OIML R 49-1:2013, 4.2) or the EUT shall detect and act upon a significant fault in compliance with ISO 4064-1:2014|OIML R 49-1:2013, [Annex B](#).
- c) During tests applied at zero flow rate, the water meter totalization shall not change by more than the value of the verification interval.

8.14 Surges on signal, data and control lines (ISO 4064-1:2014|OIML R 49-1:2013, A.5)

8.14.1 Object of the test

To verify that a water meter complies with the requirements in ISO 4064-1:2014|OIML R 49-1:2013, 5.1.1, under conditions where electrical surges are superimposed on I/O and communication ports as in ISO 4064-1:2014|OIML R 49-1:2013, Table A.1.

8.14.2 Preparation

Follow the testing arrangements specified in IEC 61000-4-5.

8.14.3 Test procedure (in brief)

- a) Measure the error (of indication) of the EUT before applying the surges.
- b) The surges have to be applied line to line and line(s) to earth. When testing line to earth, the test voltage shall be applied successively between each of the lines and earth, if there is no other specification.
- c) Measure the error (of indication) of the EUT after the application of surge transient voltages.
- d) Calculate the relative error (of indication) for each condition.
- e) Subtract the error (of indication) of the meter measured before applying the surges from that measured after the application of the surges.
- f) Examine the EUT for correct functioning.
- g) Complete the test report in ISO 4064-3:2014|OIML R 49-3:2013, 4.6.13.

Additional requirements follow.

- i) A surge generator shall be used with the performance characteristics as specified in the cited standard. The test consists of exposure to surges for which the rise time, pulse width, peak values of the output voltage/current on high/low impedance load and minimum time interval between two successive pulses are defined in the cited standard.
- ii) The characteristics of the generator shall be verified before connecting the EUT.
- iii) If the EUT is an integrating instrument (meter), the test pulses shall be continuously applied during the measuring time.
- iv) This test is only applicable for environmental class E2, for which the surge transient voltage on line to line is 1 kV, and on line to earth is 2 kV.

NOTE On unbalanced lines, the test on line to earth is normally undertaken with primary protection.

- v) This test is applicable to long signal lines (lines longer than 30 m or those lines partially or fully installed outside the buildings regardless of their length).
- vi) At least three positive and three negative surges shall be applied.
- vii) During the measurement of the error (of indication) the EUT shall be subjected to the reference flow rate.
- viii) When measuring the error (of indication), the installation and operational conditions specified in [7.4.2](#) shall be followed and the reference conditions shall be applied unless otherwise specified. Test meters not marked "V" shall be mounted with the flow axis in the horizontal orientation. Meters with two reference temperatures are only tested at the lower reference temperature.

8.14.4 Acceptance criteria

- a) After the application of the disturbance, all the functions of the EUT shall operate as designed.
- b) The difference between the relative error of indication obtained after the application of the surge transient voltages and that obtained before the test shall not exceed one-half of the MPE of the “upper zone” or the EUT shall detect and act upon a significant fault in compliance with ISO 4064-1:2014|OIML R 49-1:2013, [Annex B](#).

8.15 Surges on AC and DC mains power lines (ISO 4064-1:2014|OIML R 49-1:2013, A.5)

8.15.1 Object of the test

To verify that a water meter complies with the requirements in ISO 4064-1:2014|OIML R 49-1:2013, 5.1.1, under conditions where electrical surges are superimposed on the mains voltage as in ISO 4064-1:2014|OIML R 49-1:2013, Table A.1.

8.15.2 Preparation

Follow the testing arrangements specified in IEC 61000-4-5.

8.15.3 Test procedure (in brief)

- a) Measure the error (of indication) of the EUT before applying the surge transient voltages.
- b) If not otherwise specified, the surges have to be applied synchronized to the voltage phase at the zero-crossing and the peak value of the AC voltage wave (positive and negative).
- c) The surges have to be applied line to line and line(s) to earth. When testing line to earth the test voltage shall be applied successively between each of the lines and earth, if there is no other specification.
- d) Measure the error (of indication) of the EUT after the application of surge transient voltages.
- e) Calculate the relative error (of indication) for each condition.
- f) Subtract the error (of indication) of the meter measured before applying the surges from that measured after the application of the surges.
- g) Examine the EUT for correct functioning.
- h) Complete the test report in ISO 4064-3:2014|OIML R 49-3:2013, 4.6.14.

Additional requirements follow.

- i) A surge generator shall be used with the performance characteristics as specified in the cited standard. The test consists of exposure to surges for which the rise time, pulse width, peak values of the output voltage/current on high/low impedance load and minimum time interval between two successive pulses are defined in the cited standard.
- ii) The characteristics of the generator shall be verified before connecting the EUT.
- iii) If the EUT is an integrating instrument, the test pulses shall be continuously applied during the measuring time.
- iv) This test is only applicable for environmental class E2, for which the surge transient voltage on line to line is 1 kV, and on line to earth is 2 kV.
- v) This test is applicable to long signal lines (lines longer than 30 m or those lines partially or fully installed outside the buildings regardless of their length).

- vi) On AC mains supply lines at least three positive and three negative surges shall be applied synchronously with AC supply voltage in angles 0°, 90°, 180° and 270°.
- vii) On DC power lines, at least three positive and three negative surges shall be applied;
- viii) During the measurement of the error (of indication) the EUT shall be subjected to the reference flow rate;
- ix) When measuring the error (of indication), the installation and operational conditions specified in [7.4.2](#) shall be followed and the reference conditions shall be applied unless otherwise specified. Test meters not marked “V” shall be mounted with the flow axis in the horizontal orientation. Meters with two reference temperatures are only tested at the lower reference temperature.

8.15.4 Acceptance criteria

- a) After the application of the disturbance, all the functions of the EUT shall operate as designed.
- b) The difference between the relative error of indication obtained after the application of the surge transient voltages and that obtained before the test shall not exceed one-half of the MPE of the “upper zone” or the EUT shall detect and act upon a significant fault in compliance with ISO 4064-1:2014|OIML R 49-1:2013, [Annex B](#).

8.16 Static magnetic field (ISO 4064-1:2014|OIML R 49-1:2013, 7.2.8)

8.16.1 Test conditions

Test conditions shall be applied as set out below.

Influence factor:	influence of a static magnetic field
Type of magnet:	ring magnet
External diameter:	70 mm ± 2 mm
Internal diameter:	32 mm ± 2 mm
Thickness:	15 mm
Material:	anisotropic ferrite
Magnetization method:	axial (1 north and 1 south)
Retentivity:	385 mT to 400 mT
Coercive force:	100 kA/m to 140 kA/m
Intensity of magnetic field:	
Less than 1 mm from the surface:	90 kA/m to 100 kA/m
At 20 mm from the surface:	20 kA/m

NOTE 1 tesla = 10⁴ gauss.

8.16.2 Object of the test

To verify that a water meter — with electronic components and/or where mechanical parts may be influenced by the static magnetic field ([7.12](#)) — complies with the requirements in ISO 4064-1:2014|OIML R 49-1:2013, 7.2.8.

8.16.3 Preparation

The water meter shall be made operational in accordance with the rated operating conditions.

8.16.4 Test procedure in brief

- a) The permanent magnet is placed in contact with the EUT at a position where the action of a static magnetic field is likely to cause errors of indication that exceed the MPE and alter the correct functioning of the EUT. The location of this position is derived by trial and error and by acknowledging the type and construction of the EUT, and/or previous experience. Different positions of the magnet may be investigated.
- b) When a test position is identified, the magnet is immobilized at that position and the error (of indication) of the EUT is measured at flow rate, Q_3 .
- c) When measuring the error (of indication), the installation and operational conditions specified in [7.4.2](#) shall be followed and the reference conditions shall be applied unless otherwise specified. Meters not marked "V" shall only be tested with the flow axis in horizontal orientation. Meters with two reference temperatures shall only be tested at the lowest reference temperature.
- d) The position of the magnet, and its orientation relative to the EUT, shall be measured and recorded for each test position.
- e) Complete the test report in ISO 4064-3:2014|OIML R 49-3:2013, 4.5.11.

8.16.5 Acceptance criteria

During the application of the test conditions:

- a) all the functions of the EUT shall operate as designed;
- b) the relative error (of indication) of the EUT, at the test conditions, shall not exceed the maximum permissible error of the upper flow rate zone (see ISO 4064-1:2014|OIML R 49-1:2013, 4.2).

8.17 Absence of flow test

8.17.1 Object of the test

To verify that there is no change in the indication of the meter in the absence of either flow or water, according to the provisions in ISO 4064-1:2014|OIML R 49-1:2013, 4.2.9.

This test is only required for electronic water meters or water meters with electronic flow or volume sensors.

8.17.2 Preparation

Apply the installation and operational requirements specified in [7.4.2](#).

8.17.3 Test procedure

- a) Fill the meter with water, purging out all air.
- b) Ensure there is no flow through the measurement transducer.
- c) Observe the meter index for 15 min.
- d) Fully discharge the water from the meter.
- e) Observe the meter index for 15 min.

- f) During the test, the reference conditions for all influence quantities other than flow rate shall be maintained.
- g) Complete the test report in ISO 4064-3:2014|OIML R 49-3:2013, 4.6.15.

8.17.4 Acceptance criteria

The water meter totalization shall not change by more than the value of the verification scale interval during each test interval.

9 Test program for type evaluation

9.1 Number of samples required

For each meter type, the numbers of complete meters or their separable parts to be tested during type examination shall be as shown in ISO 4064-1:2014|OIML R 49-1:2013, Table 6.

Additional meters can be submitted in order to conduct the durability test and the other performance tests in parallel, if agreed with the notified body or body responsible for type approval.

9.2 Performance test applicable to all water meters

[Table 6](#) gives a program for testing all water meters for type evaluation. The tests shall be carried out on at least the number of samples given in ISO 4064-1:2014|OIML R 49-1:2013, Table 6, according to the meter designation, except where explicitly stated in the appropriate subclause.

Tests 1–9 may be carried out in any order. Tests 10–13 shall be carried out in the prescribed order. Test 14 shall be carried out before tests 10–13. If an additional batch of meters of the number given in ISO 4064-1:2014|OIML R 49-1:2013, Table 6, according to the meter designation, is supplied, then tests 10–13 may be carried out in parallel to the other tests.

Table 6 — Performance test program for all water meter types

Test	Subclause	Number of meters	
Tests which may be carried out in any order			
1	Static pressure	7.3	All
2	Error (of indication)	7.4	All
3	Absence of flow ^a	8.17	≥1
4	Water temperature	7.5	≥1
5	Overload water temperature ^b	7.6	≥1
6	Water pressure	7.7	≥1
7	Reverse flow	7.8	≥1
8	Pressure loss	7.9	≥1
ieao: in each applicable orientation			
a This test is only required for electronic water meters or water meters with electronic devices.			
b This test only applies to meters with a MAT ≥50 °C.			
c Only for meters with $Q_3 \leq 16 \text{ m}^3/\text{h}$.			
d Only for meters with $Q_3 > 16 \text{ m}^3/\text{h}$			
e Specific test for combination meters.			
f For combination meters where the small meter has not been previously approved.			
g For all meters with electronic components and mechanical meters equipped with a magnetic coupling in the drive to the readout or any other mechanism which may be affected by the external application of a magnetic field (7.12).			

Table 6 (continued)

	Test	Subclause	Number of meters
9	Flow disturbance	7.10	≥1
Tests to be carried out in the order given			
10	Discontinuous flow durability test at Q_3^c or at $Q \geq 2Q_{x2}^e$	7.11.2	≥1 ieao
11	Continuous flow durability test at Q_3^d	7.11.3	≥1 ieao
12	Continuous flow durability test at Q_4	7.11.3	≥1 ieao
13	Continuous flow durability test at $0,9Q_{x1}^f$	7.11.3	≥1 ieao
Test to be carried out before tests 10–13			
14	Magnetic field testing ^g	8.16	≥1
ieao: in each applicable orientation			
a This test is only required for electronic water meters or water meters with electronic devices.			
b This test only applies to meters with a MAT ≥50 °C.			
c Only for meters with $Q_3 \leq 16 \text{ m}^3/\text{h}$.			
d Only for meters with $Q_3 > 16 \text{ m}^3/\text{h}$			
e Specific test for combination meters.			
f For combination meters where the small meter has not been previously approved.			
g For all meters with electronic components and mechanical meters equipped with a magnetic coupling in the drive to the readout or any other mechanism which may be affected by the external application of a magnetic field (7.12).			

9.3 Performance tests applicable to electronic water meters, mechanical water meters fitted with electronic devices, and their separable parts

In addition to the tests listed in [Table 6](#), the performance tests listed in ISO 4064-1:2014|OIML R 49-1:2013, Table A.1 shall be applied to electronic water meters and mechanical water meters fitted with electronic devices. The tests listed in ISO 4064-1:2014|OIML R 49-1:2013, Table A.1 may be carried out in any order.

NOTE The number of meters to be supplied is given in ISO 4064-1:2014|OIML R 49-1:2013, 7.2.2.

One meter shall be submitted to all the applicable tests listed in ISO 4064-1:2014|OIML R 49-1:2013, Table A.1, according to its environmental classification. No substitutions of any remaining meters shall be permitted. The meter shall not fail any of the tests applied to it.

Where the meter is fitted with checking facilities, the same meter shall also fulfil the requirements for checking facilities specified in [Annex A](#).

9.4 Type evaluation of separable parts of a water meter

The compatibility of separable parts of a water meter shall be evaluated by the body responsible for type approval and the following rules shall be applied.

- a) The type approval certificate for a separately approved measurement transducer (including flow or volume sensor) shall state the type or types of approved calculator (including indicating device) with which it can be combined.
- b) The type approval certificate for a separately approved calculator (including indicating device) shall state the type or types of approved measurement transducer (including flow or volume sensor) with which it can be combined.
- c) The type approval certificate for a combined meter shall state which type or types of approved calculator (including indicating device) and approved measurement transducer (including flow or volume sensor) can be combined.

- d) The maximum permissible errors for the calculator (including indicating device) or measurement transducer (including flow or volume sensor) shall be declared by the manufacturer when it is submitted for type examination.
- e) The arithmetic sum of the MPEs of an approved calculator (including indicating device) and an approved measurement transducer (including flow or volume sensor) shall not exceed the MPEs for a complete water meter (see ISO 4064-1:2014|OIML R 49-1:2013, 4.2).
- f) Measurement transducers (including flow or volume sensor) of mechanical water meters, mechanical water meters fitted with electronic devices and electronic water meters shall be subjected to the applicable performance tests listed in [Table 6](#) and in ISO 4064-1:2014|OIML R 49-1:2013, Table A.1.
- g) Calculators (including indicating device) of mechanical water meters, mechanical water meters fitted with electronic devices and electronic water meters shall be subjected to the applicable performance tests listed in [Table 6](#) and in ISO 4064-1:2014|OIML R 49-1:2013, Table A.1.
- h) Wherever possible, the test conditions applied during the type evaluation of a complete water meter shall be applied to the separable parts of a water meter. Where this is not possible for certain test conditions, simulated conditions, of equivalent severity and duration, shall be applied.
- i) The performance test requirements of [Clauses 6](#) and [7](#) shall be met where applicable.
- j) The results of the type evaluation tests of separable parts of a water meter shall be declared in a report of similar format to that for a complete water meter (see ISO 4064-3|OIML R 49-3).

9.5 Families of water meters

When a family of water meters is submitted for type evaluation, the criteria in [Annex D](#) shall be applied by the body responsible for type approval in deciding if the meters conform to the definition of “a family” and in selecting which meter sizes are to be tested.

10 Tests for initial verification

10.1 Initial verification of complete and combined water meters

10.1.1 Object of the test

To verify that the relative errors (of indication) of a complete or combined water meter are within the maximum permissible errors given in ISO 4064-1:2014|OIML R 49-1:2013, 4.2.2 or 4.2.3.

The reference conditions are permitted to deviate from the defined tolerance values during the verification tests if evidence can be given to the body responsible for type approval that the type of meter under consideration is not affected by the deviation of the condition in question. The actual values of the deviating condition, however, have to be measured and documented as part of the verification test documentation.

10.1.2 Preparation

A pressure test shall be performed at 1,6 times the MAP for 1 min.

During the test no leaks shall be observed.

The errors (of indication) of the water meter shall be measured using equipment and principles specified in [7.2](#) and [7.4](#).

10.1.3 Test procedure

- a) Install the meters for testing either singly or in series.

- b) Apply the procedures given in [7.4](#).
- c) Ensure that there is no significant interaction between meters installed in series.
- d) Ensure that the outlet pressure of any meter is not less than 0,03 MPa (0,3 bar).
- e) Ensure that working water temperature range is as follows:
 - T30, T50 : 20 °C ± 10 °C;
 - T70 to T180: 20 °C ± 10 °C and 50 °C ± 10 °C;
 - T30/70 to T30/180: 50 °C ± 10 °C.
- f) Ensure that all other influence factors are held within the rated operating conditions of the meter.
- g) Unless alternative flow rates are specified in the type approval certificate, measure the errors (of indication) at the following flow rate ranges:
 - Q_1 to $1,1Q_1$;
 - Q_2 to $1,1Q_2$;
 - $0,9Q_3$ to Q_3 ;
 - for combination meters, $1,05Q_{x2}$ to $1,15Q_{x2}$.

NOTE See also [10.1.4 c\)](#).

- h) Calculate the error (of indication) for each flow rate in accordance with [Annex B](#).
- i) Complete the test report in ISO 4064-3:2014|OIML R 49-3:2013, 5.3.1, Example 1.

10.1.4 Acceptance criteria

- a) The errors (of indication) of the water meter shall not exceed the maximum permissible errors given in ISO 4064-1:2014|OIML R 49-1:2013, 4.2.2 or 4.2.3.
- b) If all the errors (of indication) of the water meter have the same sign, at least one of these errors shall not exceed one-half the maximum permissible error. In all cases this requirement shall be applied equitably with respect to the water supplier and the consumer (see also ISO 4064-1:2014|OIML R 49-1:2013, 4.3.3 paragraphs 3 and 8).
- c) Where necessary to meet the requirements of b), and in accordance with ISO 4064-1:2014|OIML R 49-1:2013, 7.3.6, additional errors at flow rates specified in ISO 4064-1:2014|OIML R 49-1:2013, 7.2.3, but other than those specified in [10.1.3 g\)](#), shall be measured.

10.2 Initial verification of separable parts of a water meter

10.2.1 Object of the test

To verify that the errors (of indication) of a measurement transducer (including volume or flow sensor) or the calculator (including indicating device) are within the maximum permissible errors stated in the type approval certificate.

A measurement transducer (including flow or volume sensors) shall be subjected to the initial verification tests listed in [10.1](#).

A calculator (including indicating devices) shall be subjected to the initial verification tests listed in [10.1](#).

10.2.2 Preparation

The errors (of indication) of separable approved parts of a water meter shall be measured using equipment and principles specified in 7.2 and the performance test requirements of 7.4 shall be met where applicable.

Where possible, the test conditions applied during the type evaluation of a complete water meter shall be applied to the separable parts of a water meter. Where this is not possible for certain test conditions, simulated conditions, of equivalent characteristics, severity, and duration, shall be applied.

10.2.3 Test procedure

The test procedure in 10.1.3 shall be followed except where simulated testing is necessary.

Complete the test report in ISO 4064-3:2014|OIML R 49-3:2013, 5.3.2, Example 2 and/or 5.3.3, Example 3.

10.2.4 Acceptance criteria

The errors (of indication) of separable parts of the water meter shall not exceed the maximum permissible errors stated in the type approval certificate.

11 Presentation of results

11.1 Object of the reports

To record and present the work carried out by the testing laboratory, including the results of the tests and examinations and all relevant information accurately, clearly and unambiguously, in the format given in ISO 4064-3|OIML R 49-3.

Implementation of the test report format as set out in ISO 4064-3|OIML R 49-3 is informative with regard to implementation of this part of ISO 4064|OIML R 49 in national regulations; however, its implementation is mandatory in the Certificate System framework of OIML B 3^[6] and the OIML Mutual Acceptance Arrangement (MAA) applicable to water meters in conformity with this part of ISO 4064|OIML R 49.

11.2 Identification and test data to be included in records

11.2.1 Type evaluation

The record of a type evaluation shall contain:

- a) a precise identification of the test laboratory and the meter tested;
- b) reference to the calibration history of all instrumentation and measuring devices used for the tests;
- c) exact details of the conditions during which the various tests were carried out, including any specific test conditions advised by the manufacturer;
- d) the results and conclusions of the tests, as required in this part of ISO 4064|OIML R 49 (ISO 4064-2|OIML R 49-2);
- e) the limitations applying to the application of separately approved measurement transducers and calculators.

11.2.2 Initial verification

The record of an initial verification test for an individual meter shall include as a minimum:

- a) identification of the testing laboratory:
 - 1) name and address;
- b) identification of the meter tested:
 - 2) name and address of the manufacturer or the trademark used;
 - 3) accuracy class;
 - 4) temperature class;
 - 5) meter designation Q_3 ;
 - 6) ratios Q_3/Q_1 ;
 - 7) maximum pressure loss (and corresponding flow rate);
 - 8) year of manufacture and the serial number of the meter tested;
 - 9) type or model;
 - 10) the results and conclusions of the tests.

Annex A (normative)

Type examination and testing of checking facilities of electronic devices

A.1 General

These requirements only apply to electronic water meters and electronic devices fitted to mechanical water meters where checking facilities are present.

NOTE Checking facilities are required only where the delivered volume of water is prepaid by the customer and cannot be confirmed by the supplier. Checking facilities are *not* required where measurements are non-resettable and there are two constant partners.

To comply with this part of ISO 4064|OIML R 49, water meters equipped with checking facilities shall pass the design inspection and performance tests specified in ISO 4064-1:2014|OIML R 49-1:2013, 7.2.11.

One sample of the complete water meter, or the calculator (including indicating device), or the measurement transducer (including flow or volume sensor), shall be subjected to all of the applicable examinations and tests specified in this Annex (see also [9.3](#)).

After each test and examination, the appropriate section references in ISO 4064-1:2014|OIML R 49-1:2013, 5.1.3 and B.1 to B.6 on checking facilities shall be completed in 5.1.3 in ISO 4064-3:2014|OIML R 49-3:2013, 4.4.1.

The sample submitted for examination shall not fail any of the tests applied to it.

A.2 Object of the examination

- a) To verify that the checking facilities of water meters fitted with such facilities meet the requirements specified in ISO 4064-1:2014|OIML R 49-1:2013, [Annex B](#).
- b) To verify that water meters having these checking facilities either prevent or detect reverse flow, as required in ISO 4064-1:2014|OIML R 49-1:2013, 5.1.3.
- c) To verify that the checking facilities associated with the measurement transducer meet the requirements specified in ISO 4064-1:2014|OIML R 49-1:2013, B.2.

A.3 Examination procedures

A.3.1 Action of checking facilities (ISO 4064-1:2014|OIML R 49-1:2013, B.1)

- a) Verify that the detection by the checking facilities of significant faults results in the following actions, according to the type.
- b) For checking facilities of type P or type I:
 - 1) automatic correction of the fault; or
 - 2) stopping only the faulty device when the water meter without that device continues to comply with the regulations; or

- 3) a visible or audible alarm, which shall continue until the cause is suppressed. In addition, when a water meter transmits data to peripheral equipment, the transmission shall be accompanied by a message indicating the presence of a fault. This requirement is not applicable to the application of disturbances specified in ISO 4064-1:2014|OIML R 49-1:2013, A.5.
- c) If the instrument is provided with devices to estimate the amount of water having passed through the meter during the occurrence of the fault, verify that the result of this estimate cannot be mistaken for a valid indication.
- d) Where checking facilities are used, verify that, in the following cases, there is no visible or audible alarm unless this alarm is transferred to a remote station:
 - 1) two constant partners;
 - 2) non-resettable measurements;
 - 3) non-prepaid measurements.
- e) If the measured values from the meter are not repeated at a remote station, verify that the transmission of the alarm and the repeated measured values are secured.

A.3.2 Checking facilities for the measurement transducer (ISO 4064-1:2014|OIML R 49-1:2013, B.2)

A.3.2.1 Object of the test

To ensure that the checking facilities verify that:

- a) the measurement transducer is present and is operating correctly,
- b) data are transmitted correctly from the measurement transducer to the calculator, and
- c) reverse flow is detected and/or prevented, where electronic means are used for this function.

A.3.2.2 Test procedures

A.3.2.2.1 Measurement transducer (including flow or volume sensor) with pulse output signals

When the signals generated by the measurement transducer are in the form of pulses, each pulse representing an elementary volume, carry out tests to determine that the checking facilities for pulse generation, transmission and counting fulfil the following tasks:

- a) correct counting of pulses;
- b) detection of reverse flow, where applicable;
- c) checking of correct function.

These type P checking functions may be tested by means of one of:

- 1) disconnecting the flow sensor from the calculator; or
- 2) interrupting the signal from the flow sensor to the calculator; or
- 3) interrupting the electrical supply to the flow sensor.

A.3.2.2.2 Measurement transducer (including flow or volume sensor) of electromagnetic meters

For electromagnetic meters, in which the amplitude of the signal generated by the flow sensor is proportional to the flow rate, the following procedure may be used to test the checking facilities.

- a) Apply a simulated input signal, with a shape similar to that of the measurement signal of the meter and representing a flow rate between Q_1 and Q_4 , to the calculator and verify the following:
 - 1) that the checking facility is of type P or type I;
 - 2) that, where the checking facility is of type I, its checking function occurs at intervals of 5 min or less;
 - 3) that the checking facility checks the flow sensor and the calculator functions;
 - 4) that the equivalent digital value of the signal is within pre-determined limits stated by the manufacturer and that it is consistent with the maximum permissible errors.
- b) Verify that the cable length between the flow sensor and the calculator or ancillary device of an electromagnetic water meter does not exceed either 100 m or the value L expressed in metres according to the following formula, whichever is smaller:

$$L = \frac{k\sigma}{fC}$$

where

$$k = 2 \times 10^{-5} \text{ m}$$

σ is the conductivity of the liquid, in S/m;

f is the field frequency during the measuring cycle, in Hz;

C is the effective cable capacitance per metre, in F/m.

If the manufacturer's solutions ensure equivalent results, these requirements can be ignored.

A.3.2.2.3 Other measuring principles

When a measurement transducer (including a flow or volume sensor) employing technologies not covered in ISO 4064-1:2014|OIML R 49-1:2013, B.2 is submitted for type evaluation, verify that the checking facilities provide equivalent levels of security.

A.3.3 Checking facilities for the calculator (ISO 4064-1:2014|OIML R 49-1:2013, B.3)

A.3.3.1 Object of the test

To verify that the checking facilities ensure that the calculator functions correctly and that the calculations are valid.

A.3.3.2 Test procedure

A.3.3.2.1 Calculator functions

- a) Verify that the checking facilities for validating the calculator functions are of either type P or type I.
- b) For type I facilities, verify that the calculator function checks are made at least once per day or at each volume equivalent to 10 min of flow at Q_3 .

- c) Verify that the checking facilities for validating the functioning of the calculator ensure that the values of all permanently memorized instructions and data are correct by such means as:
 - 1) summing all instruction and data codes and comparing the sum with a fixed value;
 - 2) line and column parity bits (LRC and VRC);
 - 3) cyclic redundancy check (CRC 16);
 - 4) double independent storage of data;
 - 5) storage of data in “safe coding”, for example protected by checksum, line and column parity bits.
- d) Verify that all internal transfers and storage of data relevant to the measurement result are performed correctly by such means as:
 - 1) read–write routines;
 - 2) conversion and re-conversion of codes;
 - 3) use of “safe coding” (check sum, parity bit);
 - 4) double storage.

A.3.3.2.2 Calculations

- a) Verify that the checking facilities for validating the calculations are of either type P or type I.
- b) For type I facilities, verify that the calculation checks are made at least once per day or at each volume equivalent to 10 min of flow at Q_3 .
- c) Verify that the values of all data related to the measurement, either stored internally or transmitted to peripheral equipment through an interface, are correct.

The checking facilities may use such means as parity bit, check sum or double storage for checking the integrity of the data.

- d) Verify that the calculation system is provided with a means of controlling the continuity of the calculation program.

A.3.4 Checking facilities for the indicating device (ISO 4064-1:2014|OIML R 49-1:2013, B.4)

A.3.4.1 Object of the test

- a) To verify that the checking facilities for the indicating device detect that the primary indications are displayed and that they correspond to the data provided by the calculator.
- b) To verify that the checking facilities for the indicating device detect the presence of the indicating device if it is removable.
- c) To verify that the checking facilities for the indicating device are of the form defined in ISO 4064-1:2014|OIML R 49-1:2013, either B.4.2 or B.4.3.

A.3.4.2 Test procedure

- a) Confirm that the checking facility of the primary indicating device is of type P;

NOTE 1 If the indicating device is not the primary indicating device, the checking facility can be of type I.

NOTE 2 The means used for checking include:

- 1) for indicating devices using incandescent filaments or LEDs, measuring the current in the filaments;
- 2) for indicating devices using fluorescent tubes, measuring the grid voltage;
- 3) for indicating devices using multiplexed liquid crystals, output checking of the control voltage of segment lines and of common electrodes, so as to detect any disconnection or short circuit between control circuits.

NOTE 3 The checks mentioned in ISO 4064-1:2014|OIML R 49-1:2013, 6.7.2.2 are not required.

- b) Verify that the checking facility for the indicating device includes type P or type I checking of the electronic circuits used for the indicating device (except the driving circuits of the display itself).
- c) Verify for type I facilities that the checks on the indicating device are made at least once per day or at each volume equivalent to 10 min of flow at Q_3 .
- d) Verify that the values of all data related to the measurement, either stored internally or transmitted to peripheral equipment through an interface, are correct.

The checking facilities may use such means as parity bit, check sum or double storage for checking the integrity of the data.

- e) Verify that the indicating device is provided with a means for controlling the continuity of the calculation program.
- f) Verify that the checking facility of the indicating device is working, either:
 - 1) by disconnecting all or part of the indicating device; or
 - 2) by an action that simulates a failure in the display, such as using a test button.

A.3.5 Checking facilities for ancillary devices (ISO 4064-1:2014|OIML R 49-1:2013, B.5)

A.3.5.1 Object of the test

- a) To verify that an ancillary device (repeating device, printing device, memory device, etc.) with primary indications includes a checking facility of type P or I.
- b) To verify that the checking facilities for ancillary devices verify:
 - 1) the presence of the ancillary device;
 - 2) that the ancillary device is functioning correctly;
 - 3) that the data are transmitted correctly between the meter and the ancillary device.

A.3.5.2 Test procedure

- a) Verify that the ancillary device (repeating device, printing device, memory device, etc.) with primary indications includes a checking facility of type P or I.
- b) Verify that the checking facility verifies that the ancillary device is connected to the water meter.
- c) Verify that the checking device verifies that the ancillary device is functioning and transmitting data correctly.

A.3.6 Checking facilities for associated measuring instruments (ISO 4064-1:2014|OIML R 49-1:2013, B.6)

A.3.6.1 Object of the test

- a) To examine the checking facilities of associated measuring instruments other than the flow sensor.

NOTE In addition to the primary measurement of volume, water meters can have integrated facilities for measuring and displaying other parameters, e.g. flow rate, water pressure, and water temperature.

- b) To verify the presence of a checking facility of either type P or type I where additional measurement functions are present.
- c) To verify that the checking facility ensures that the signal from each associated instrument is within a predetermined measuring range.

A.3.6.2 Test procedure

- a) Identify the number and types of associated measurement transducers present in the meter.
- b) For each type of transducer present, verify that a checking facility of type P or type I is present.
- c) Verify that the value of the signal from each transducer agrees with the parameter being measured (flow rate, water pressure, and water temperature).
- d) Where flow rates are to be used for controlling tariffs, verify that for each flow rate specified in ISO 4064-1:2014|OIML R 49-1:2013, 7.2.3 the difference between the actual flow rate and the indicated flow rate does not exceed the appropriate MPE in ISO 4064-1:2014|OIML R 49-1:2013, 4.2.2 or 4.2.3.
- e) For all other types of associated measuring instrument, verify that the difference between the actual value of the parameter being measured and the value indicated by the measuring instrument at the extremes and at the mid-point of their measuring range, does not exceed the maximum error stated by the manufacturer.

Annex B **(normative)**

Calculating the relative error (of indication) of a water meter

B.1 General information

This annex defines the formulae to be applied during type evaluation and verification tests, when calculating the error (of indication) of a:

- a) complete water meter;
- b) separable calculator (including indicating device);
- c) separable measurement transducer (including flow or volume sensor).

B.2 Calculation of the error (of indication)

When either a measurement transducer (including flow or volume sensor) or a calculator (including indicating device) of a water meter is submitted for separable type approval, error (of indication) measurements are carried out only on these separable parts of the meter.

For a measurement transducer (including flow or volume sensor), the output signal (pulse, current, voltage or encoded) is measured by a suitable instrument.

For the calculator (including indicating device), the characteristics of simulated input signals (pulse, current, voltage or encoded) should replicate those of the measurement transducer (including flow or volume sensor).

The error (of indication) of the EUT is calculated according to what is considered to be the reference volume added during a test, compared with the equivalent volume of either the simulated input signal to the calculator (including indicating device), or the actual output signal from the measurement transducer (including flow or volume sensor), measured during the same test period.

Unless exempted by the metrological authority, a measurement transducer (including flow or volume sensor) and a compatible calculator (including indicating device) have separate type approvals, and shall be tested together as a combined water meter during initial verification (see [Clause 10](#)). Therefore, the calculation for the error (of indication) is the same as for a complete water meter.

B.3 Calculation of the relative error (of indication)

B.3.1 Complete water meter

$$E_{m(i)(i=1,2,\dots,n)} = \frac{V_i - V_a}{V_a} \times 100\% \quad (\text{B.1})$$

where

$E_{m(i)(i=1,2,\dots,n)}$ is the relative error (of indication), expressed as a percentage, of a complete water meter at a flow rate i ($i = 1, 2 \dots n$);

V_a is the reference (or simulated) volume passed, during the test period t_d , m^3 ;

V_i is the volume added to (or subtracted from) the indicating device, during the test period t_d , m^3 .

B.3.2 Combined water meter

A combined water meter shall be treated as a complete water meter ([B.3.1](#)) for the purpose of calculating the error (of indication).

B.3.3 Calculator (including indicating device)

B.3.3.1 Calculation of the relative error (of indication) of a calculator (including indicating device) tested with a simulated pulse input signal

$$E_{c(i)(i=1,2,\dots,n)} = \frac{V_i - V_a}{V_a} \times 100\% \quad (\text{B.2})$$

where

$E_{c(i)(i=1,2,\dots,n)}$ is the relative error (of indication), expressed as a percentage, of the calculator (including indicating device) at a flow rate i ($i = 1, 2 \dots n$);

V_i is the volume registered by the indicating device, added during the test period t_d , m^3 ;

$V_a = C_p T_p$ is the water volume equivalent to the total number of volume pulses injected into the indicating device during the test period t_d , m^3

in which

C_p is the constant equating a nominal volume of water to each pulse, m^3/pulse ,

T_p is the total number of volume pulses injected during the test period t_d , pulses.

B.3.3.2 Calculation of the relative error (of indication) of a calculator (including indicating device) tested with a simulated current input signal

$$E_{c(i)(i=1,2\dots n)} = \frac{V_i - V_a}{V_a} \times 100 \% \quad (\text{B.3})$$

where

$E_{c(i)(i = 1, 2 \dots n)}$ is the relative error (of indication), expressed as a percentage, of the calculator (including indicating device) at a flow rate i ($i = 1, 2 \dots n$);

V_i is the volume registered by the indicating device, added during the test period t_d , m^3 ;

$V_a = C_I I_t t_d$ is the water volume equivalent to the average signal current injected into the calculator during the test period t_d , m^3

in which

C_I is the constant relating the current signal to the flow rate, $\text{m}^3 \cdot \text{h}^{-1} \cdot \text{mA}^{-1}$,

t_d is the duration time of the test period, h,

I_t is the average current input signal during the test period t_d , mA.

B.3.3.3 Calculation of the relative error (of indication) of a calculator (including indicating device) tested with a simulated voltage input signal

$$E_{c(i)(i=1,2\dots n)} = \frac{V_i - V_a}{V_a} \times 100 \% \quad (\text{B.4})$$

where

$E_{c(i)(i = 1, 2 \dots n)}$ is the relative error (of indication), expressed as a percentage, of the calculator (including indicating device) at a flow rate i ($i = 1, 2 \dots n$);

V_i is the volume registered by the indicating device, added during the test period t_d , m^3 ;

$V_a = C_U U_c t_d$ is the water volume equivalent to the average signal voltage injected into the calculator during the test period t_d , (m^3)

in which

C_U is the constant relating the voltage input signal to the flow rate, $\text{m}^3 \cdot \text{h}^{-1} \cdot \text{V}^{-1}$,

t_d is the duration time of the test period, h,

U_c is the average value of the voltage input signal during the test period t_d , V.

B.3.3.4 Calculation of the relative error (of indication) of a calculator (including indicating device) tested with a simulated, encoded input signal

$$E_{c(i)(i=1,2\dots n)} = \frac{V_i - V_a}{V_a} \times 100 \% \quad (\text{B.5})$$

where

$E_{c(i)(i=1,2\dots n)}$ is the relative error (of indication), expressed as a percentage, of the calculator (including indicating device) at a flow rate i ($i = 1, 2 \dots n$);

V_a is the water volume equivalent to the numerical value of the encoded input signal, injected into the indicating device during the test period t_d , m^3 ;

V_i is the volume registered by the indicating device, added during the test period t_d , m^3 .

B.3.4 Measurement transducer (including flow or volume sensor)

B.3.4.1 Calculation of the relative error (of indication) of a measurement transducer (including flow or volume sensor) with a pulse output signal

$$E_{t(i)(i=1,2\dots n)} = \frac{V_i - V_a}{V_a} \times 100 \% \quad (\text{B.6})$$

where

$E_{t(i)(i=1,2\dots n)}$ is the relative error (of indication), expressed as a percentage, of a measurement transducer (including flow or volume sensor) at a flow rate i ($i = 1, 2 \dots n$);

V_a is the reference volume of water collected during the test period t_d , m^3 ;

$V_i = C_p T_p$ is the water volume equivalent to the total number of volume pulses emitted from the measurement transducer during the test period t_d , m^3

in which

C_p is the constant equating a nominal volume of water to each output pulse, m^3/pulse ;

T_p is the total number of volume pulses emitted during the test period t_d , pulses.

B.3.4.2 Calculation of the relative error (of indication) of a measurement transducer (including flow or volume sensor) with a current output signal

$$E_{t(i)(i=1,2\dots n)} = \frac{V_i - V_a}{V_a} \times 100 \% \quad (\text{B.7})$$

where

- $E_{t(i)(i = 1, 2 \dots n)}$ is the relative error (of indication), expressed as a percentage, of a measurement transducer (including flow or volume sensor) at a flow rate i ($i = 1, 2 \dots n$);
- V_a is the reference volume of water collected during the test period t_d , m³;
- $V_i = C_I I_t t_d$ is the water volume equivalent to the average current output signal emitted from the measurement transducer (including flow or volume sensor) during the test period t_d , m³

in which

- C_I is the constant relating the output signal current to the flow rate, m³·h⁻¹·mA⁻¹,
- t_d is the duration time of the test period, h,
- I_t is the average current output signal emitted during the test period t_d , mA.

B.3.4.3 Calculation of the relative error (of indication) of a measurement transducer (including flow or volume sensor) with a voltage output signal

$$E_{t(i)(i=1,2\dots n)} = \frac{V_i - V_a}{V_a} \times 100 \% \quad (\text{B.8})$$

where

- $E_{t(i)(i = 1, 2 \dots n)}$ is the relative error (of indication), expressed as a percentage, of a measurement transducer (including flow or volume sensor) at a flow rate i ($i = 1, 2 \dots n$);
- V_a is the reference volume of water collected during the test period t_d , m³;
- $V_i = C_U t_d U_t$ is the volume of water equivalent to the average signal voltage emitted by the measurement transducer (including flow or volume sensor) and its duration, measured during the test period t_d , (m³)

in which

- C_U is the constant relating the voltage output signal emitted to the flow rate, m³·h⁻¹·V⁻¹,
- t_d is the duration time of the test period, h,
- U_t is the average voltage output signal emitted during the test period t_d , V.

B.3.4.4 Calculation of the relative error (of indication) of a measurement transducer (including flow or volume sensor) with an encoded output signal

$$E_{t(i)(i=1,2\dots n)} = \frac{V_i - V_a}{V_a} \times 100 \% \quad (\text{B.9})$$

where

$E_{t(i)(i = 1, 2 \dots n)}$ is the relative error (of indication), expressed as a percentage, of a measurement transducer (including flow or volume sensor) at a flow rate i ($i = 1, 2 \dots n$);

V_a is the reference volume of water collected during the test period t_d , m³;

V_i is the volume of water equivalent to the numerical value of the encoded output signal emitted from the measurement transducer (including flow or volume sensor) during the test period t_d , m³.

Annex C (normative)

Installation requirements for flow disturbance tests

Installation requirements for flow disturbance tests are shown in [Figure C.1](#). The straightener may be a straightener assembly consisting of a straightener and a straight length between it and the flowmeter.

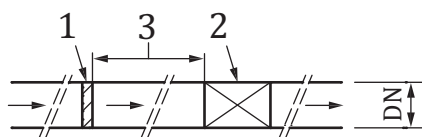

Test 1: without a straightener

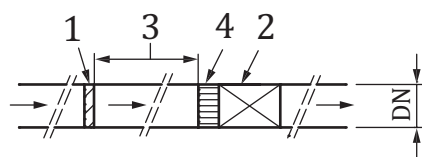

Test 1A: with a straightener

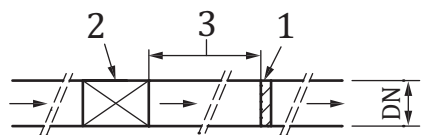

Test 2: without a straightener

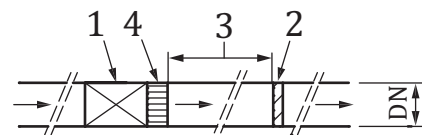

Test 2A: with a straightener

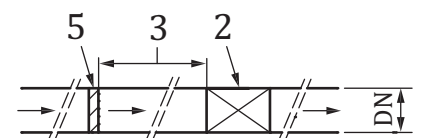

Test 3: without a straightener

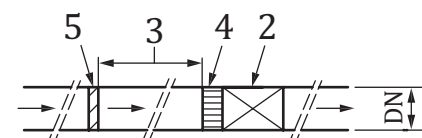

Test 3A: with a straightener

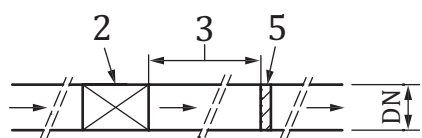

Test 4: without a straightener

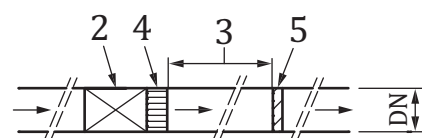

Test 4A: with a straightener

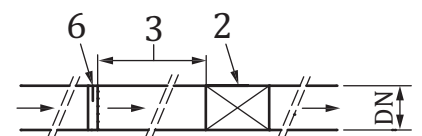

Test 5: without a straightener

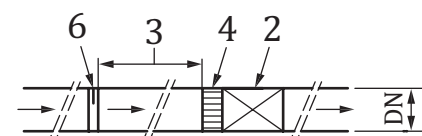

Test 5A: with a straightener

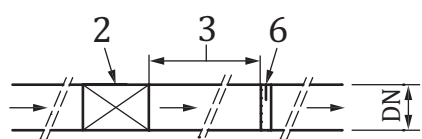

Test 6: without a straightener

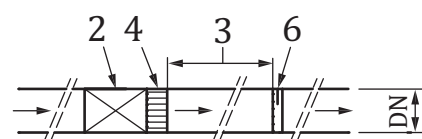

Test 6A: with a straightener

Key

Flow disturbance scheme

- | | |
|---|--|
| 1 type 1 disturber — swirl generator sinistrorsal | 4 straightener |
| 2 meter | 5 type 2 disturber — swirl generator dextrorsal |
| 3 straight length | 6 type 3 disturber — velocity profile flow disturber |

Figure C.1 — Installation requirements for flow disturbance tests

Annex D (normative)

Type evaluation of a family of water meters

D.1 Families of water meters

This annex describes the criteria to be applied by the body responsible for type approval in deciding whether a group of water meters can be considered to be from the same family for type approval purposes, where only selected meter sizes are to be tested.

D.2 Definition

A family of meters is a group of water meters of different sizes and/or different flow rates, in which all the meters shall have the following characteristics:

- the same manufacturer;
- geometric similarity of the wetted parts;
- the same metering principle;
- the same ratios Q_3/Q_1 ;
- the same accuracy class;
- the same temperature class;
- the same electronic device for each meter size;
- a similar standard of design and component assembly;
- the same materials for those components that are critical to the performance of the meter;
- the same installation requirements relative to the meter size, e.g. $10D$ (pipe diameter) of straight pipe upstream of the meter and $5D$ of straight pipe downstream of the meter.

D.3 Meter selection

When considering which sizes of a family of water meters should be tested, the following rules shall be followed.

- a) The body responsible for type approval shall declare the reasons for including and omitting particular meter sizes from testing.
- b) The smallest meter in any family of meters shall always be tested.
- c) Meters which have the most extreme operating parameters within a family, shall be considered for testing, e.g. the largest flow rate range, the highest peripheral (tip) speed of moving parts, etc.
- d) If practical, the largest meter in any family of meters should always be tested. However, if the largest meter is not tested, then any meter having $Q_3 > 2Q_3$ of the largest meter tested shall not be approved as part of a family.
- e) Durability tests will only be required on the size of meters where the highest wear is expected.

- f) For meters with no moving parts in the measurement transducer, the smallest size shall be selected for durability tests.
- g) Tests in more than one orientation are only required in the meter size for which the durability test is carried out.
- h) All performance tests relating to influence quantities and disturbances shall be carried out on one size from a family of meters.
- i) The static pressure test (7.3), water temperature test (7.5), overload water temperature test (7.6), water pressure test (7.7), reverse flow test (7.8), pressure loss test (7.9), flow disturbance test (7.10), magnetic field test (8.16), and absence of flow test (8.17) are required for the smallest size meter and one other size. For families of meters where all meter sizes have DN ≥300, it is only necessary to test one size of meter.
- j) The family members underlined in Figure D.1 may be considered as an example for testing.

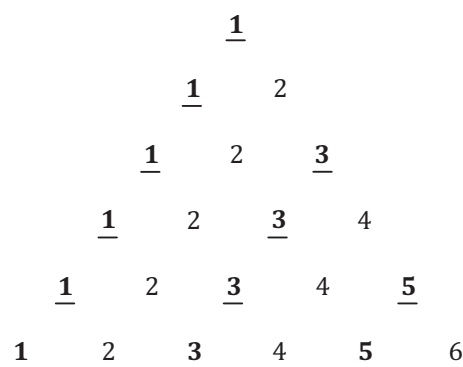

NOTE 1 Each row represents one family, meter 1 being the smallest.

NOTE 2 Families may be as large as is wished.

Figure D.1 — Example representation of meter family members to be tested

Annex E (informative)

Examples of methods and components used for testing concentric water meters

[Figure E.1](#) shows an example of a manifold connection for a concentric water meter.

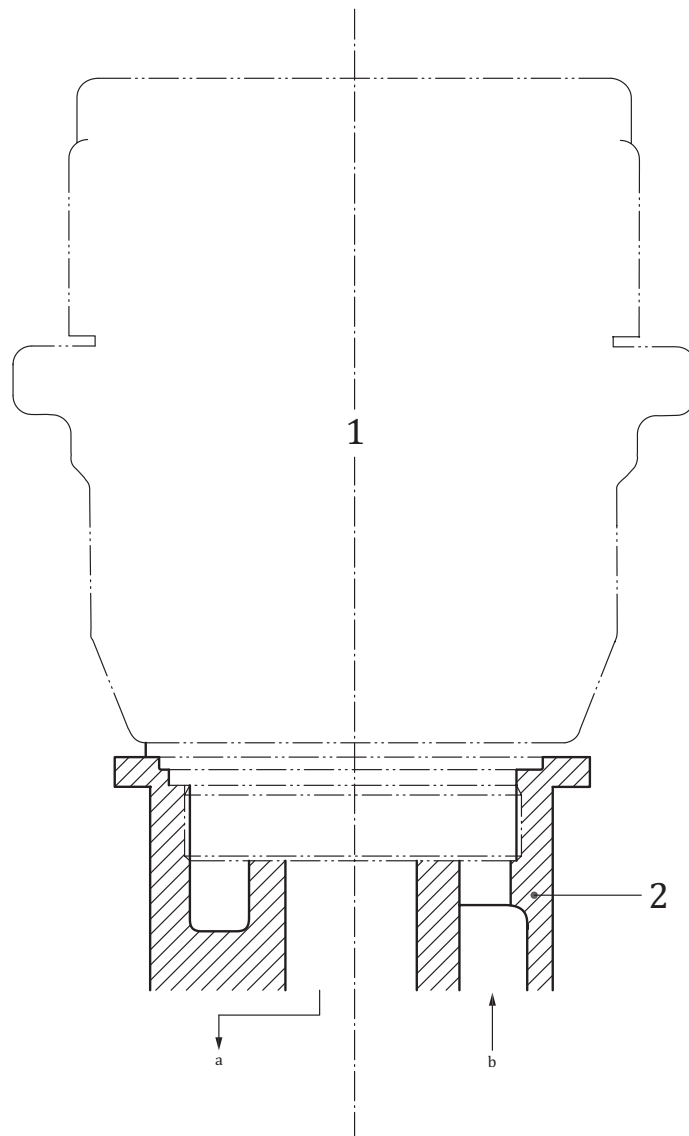

Key

1 concentric water meter

a Water flow out.

2 concentric water meter manifold (part view)

b Water flow in.

Figure E.1 — Example of a manifold connection for a concentric water meter

A special pressure test manifold such as that shown in the example in [Figure E.2](#) may be used to test the meter. To ensure that the seals are operating at their 'worst case' during the test, the sealing face

dimensions of the pressure test manifold should be at the appropriate limits of their manufacturing tolerances, in accordance with the design dimensions specified by the manufacturer.

Before being submitted for type evaluation, the meter manufacturer may be required to seal the meter at a point above the location of the inner seal of the meter/manifold interface, by a means suited to the meter design. When the concentric meter is fitted to the pressure test manifold and pressurized, it is necessary to be able to see the source of any leak flowing from the pressure test manifold outlet and to distinguish between it and that issuing from an incorrectly fitted sealing device. [Figure E.3](#) shows an example of a design of plug suited to many meter designs, but any other suitable means may be used.

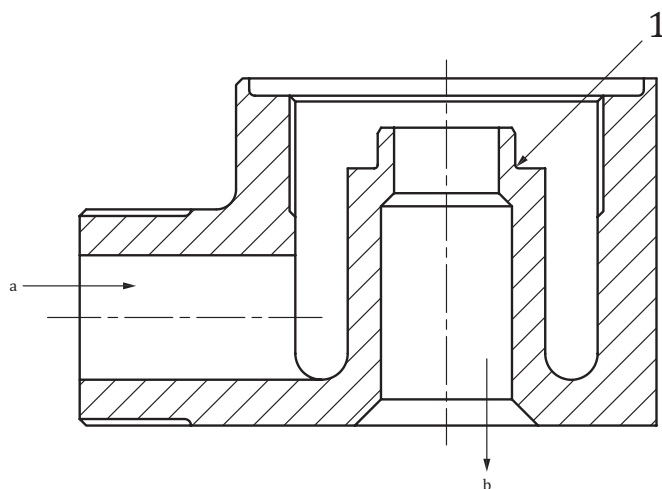

Key

- 1 position of inner seal
- a Pressure.
- b Path of leakage water passing seal.

Figure E.2 — Example of a manifold for pressure testing concentric meter seals

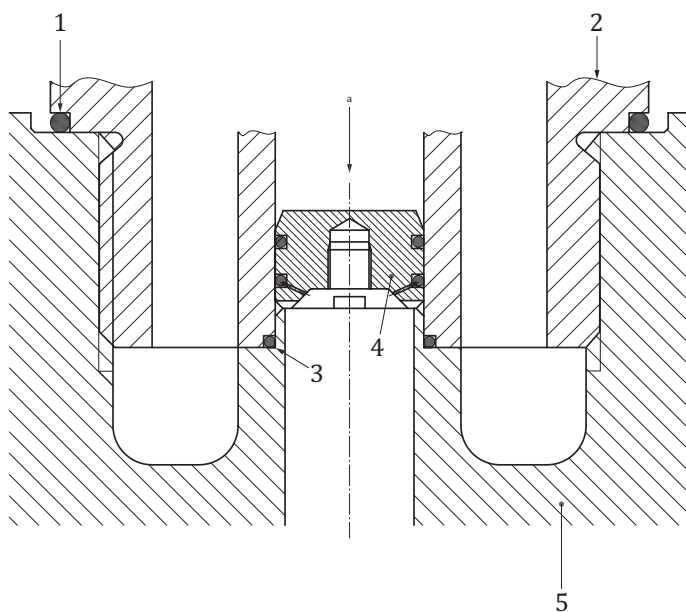

a) Section through meter and manifold showing test plug in position

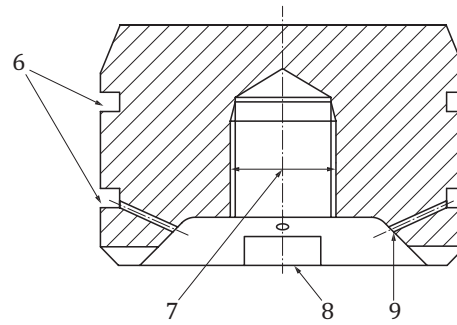

b) Detail of test plug

Key

- | | | | |
|---|---------------------------------------|---|-----------------------------|
| 1 | meter outer seal | 6 | O-ring grooves |
| 2 | meter | 7 | tapping for withdrawal bolt |
| 3 | meter inner seal | 8 | 4–6 gashes, equi-spaced |
| 4 | test plug [see enlarged detail in b)] | 9 | “witness” leakage hole |
| 5 | manifold | a | Pressure. |

Figure E.3 — Example of a plug for pressure testing concentric meter seals

Annex F (informative)

Determining the density of water

The density of water in the test meter is calculated from the International Association for the Properties of Water and Steam (IAPWS) formulations as follows.

F.1 Density of air-free distilled water at 101,325 kPa

$$\rho_{\text{dw}}(t) = a_0 \left(\frac{1 + a_1\theta + a_2\theta^2 + a_3\theta^3}{1 + a_4\theta + a_5\theta^2} \right) \quad (\text{F.1})$$

where

$\rho_{\text{dw}}(t)$ is the density of air-free distilled water at temperature t , in kg/m³;

θ is a normalized temperature, $\theta = t/100$;

t is the temperature, in °C, on the ITS-90 temperature scale;

a_i are the coefficients of the equation, given in the following table.

a_i					
$i = 0$	$i = 1$	$i = 2$	$i = 3$	$i = 4$	$i = 5$
999,843 82	1,463 938 6	-0,015 505 0	-0,030 977 7	1,457 209 9	0,064 893 1

F.2 Pressure correction factor

$$B = a_0 \left(\frac{1 + a_1\theta + a_2\theta^2 + a_3\theta^3}{1 + a_4\theta} \right) \quad (\text{F.2})$$

where

B is the isothermal compressibility of water at ambient pressure, in Pa⁻¹;

θ is a normalized temperature, $\theta = t/100$;

t is the temperature in °C (ITS-90);

a_i are the coefficients of the equation, given in the following table.

a_i				
$i = 0$	$i = 1$	$i = 2$	$i = 3$	$i = 4$
$5,088 21 \times 10^{-10}$	1,263 941 8	0,266 026 9	0,373 483 8	2,020 524 2

F.3 Density of water at the flowmeter

$$\rho_w(t) = \rho_{dw}(1 + Bp)d_{H_2O} \quad (F.3)$$

where

p is the gauge pressure at the flowmeter (Pa);

d_{H_2O} is ratio of the density of water from the test facility to that of pure water, measured at the same conditions (normally ambient temperature and pressure).

NOTE 1 Formulae (F.1) to (F.3) are derived from the IAPWS-95 (Reference[2]) formulations and are valid for temperatures up to 80 °C. Where temperatures exceed 80 °C, the full equations of state provided by IAPWS-95 or -98 formulations should be used. The full formulae allow for the calibration of hot water meters and calibrations at pressure. Equations for the density of distilled water as suggested in References[8]–[10] are suitable for use in legal metrology, usually in the determination of volume by weighing at atmospheric conditions. They are not recommended for water meter calibrations as they only apply to temperatures up to 40 °C and do not have associated pressure correction formulae.

NOTE 2 A table of densities calculated from the IAPWS formulation of air-free distilled water and applying for temperatures between 0 °C and 80 °C and a pressure of 101,325 kPa is given in [Table F.1](#).

Table F.1 — Density of air-free distilled water [from Formula (F.1)]

Water temperature °C	Density kg/m ³	Water temperature °C	Density kg/m ³	Water temperature °C	Density kg/m ³	Water temperature °C	Density kg/m ³
0	999,84	20	998,21	40	992,22	60	983,20
1	999,90	21	998,00	41	991,83	61	982,68
2	999,94	22	997,77	42	991,44	62	982,16
3	999,97	23	997,54	43	991,04	63	981,63
4	999,98	24	997,30	44	990,63	64	981,09
5	999,97	25	997,05	45	990,21	65	980,55
6	999,94	26	996,79	46	989,79	66	980,00
7	999,90	27	996,52	47	989,36	67	979,45
8	999,85	28	996,24	48	988,93	68	978,90
9	999,78	29	995,95	49	988,48	69	978,33
10	999,70	30	995,65	50	988,04	70	977,76
11	999,61	31	995,34	51	987,58	71	977,19
12	999,50	32	995,03	52	987,12	72	976,61
13	999,38	33	994,71	53	986,65	73	976,03
14	999,25	34	994,37	54	986,17	74	975,44
15	999,10	35	994,03	55	985,69	75	974,84
16	998,95	36	993,69	56	985,21	76	974,24
17	998,78	37	993,33	57	984,71	77	973,64
18	998,60	38	992,97	58	984,21	78	973,03
19	998,41	39	992,60	59	983,71	79	972,41
20	998,21	40	992,22	60	983,20	80	971,79

Values are taken from Reference.[[2]]

Annex G (informative)

Maximum uncertainties in the measurement of influence factors and disturbances

G.1 Introduction

[G.2](#) to [G.10](#) list the maximum uncertainties that may be applied to the various performance tests. It should be assumed that these uncertainties include a coverage factor $k = 2$.

Where an influence quantity is stated as a nominal value with tolerances, e.g. $55 \pm 2 \text{ }^\circ\text{C}$, the nominal value of the influence quantity ($55 \text{ }^\circ\text{C}$ in the example) is the intended value for the test. However, in order to comply with the stated tolerance for the influence quantity, the uncertainty of the measuring instrument which is used to measure that quantity shall be subtracted from the absolute value of the tolerance to obtain the actual tolerance limits to be applied during a test.

EXAMPLE If the air temperature has to be set to $55 \pm 2 \text{ }^\circ\text{C}$ and the uncertainty of the temperature measuring instrument is $0,4 \text{ }^\circ\text{C}$, then the actual temperature during the test shall be $55 \pm 1,6 \text{ }^\circ\text{C}$.

Where the influence quantity is given as a range, e.g. the ambient air temperature is $15 \text{ }^\circ\text{C}$ to $25 \text{ }^\circ\text{C}$, this implies that the influence from this effect is not significant. However, the air temperature should be at a steady value within that range, in this case at normal ambient temperature.

G.2 Simulated signal inputs to calculator

Resistance:	0,2 % of applied resistance
Current:	0,01 % of applied current
Voltage	0,01 % of applied voltage
Pulse frequency:	0,01 % of applied frequency

G.3 Dry heat, damp heat (cyclic) and cold tests

Water pressure:	5 %
Ambient air pressure:	0,5 kPa
Water temperature:	0,4 $^\circ\text{C}$
Ambient air temperature:	0,4 $^\circ\text{C}$
Humidity:	0,6 %
Time (t) (Duration of application of influence quantity):	
$0 < t < 2 \text{ h}$:	1 s
$t > 2 \text{ h}$:	10 s

G.4 Supply voltage variation

Voltage (mains AC):	$\leq 0,2$ % of applied voltage
Voltage (mains AC/DC.):	$\leq 0,2$ % of applied voltage
Voltage (batteries):	$\leq 0,2$ % of applied voltage
Mains frequency:	$\leq 0,2$ % of applied frequency
Harmonic distortion:	$\leq 0,2$ % of applied current

G.5 Mains frequency variation

Mains voltage:	$\leq 0,2$ % of applied voltage
Mains frequency:	$\leq 0,2$ % of applied frequency
Harmonic distortion:	$\leq 0,2$ % of applied current

G.6 Short time power reduction

Applied voltage:	$\leq 0,2$ % of nominal mains voltage
Mains frequency:	$\leq 0,2$ % of applied frequency
Harmonic distortion:	$\leq 0,2$ % of applied current

G.7 Electrical bursts

Mains voltage:	$\leq 0,2$ % of applied voltage
Mains frequency:	$\leq 0,2$ % of applied frequency
Voltage transients:	$\leq 0,2$ % of peak voltage
Time (t):	
$15 \text{ ms} < t < 300 \text{ ms}$:	$\leq 1 \text{ ms}$
$5 \text{ ns} < t < 50 \text{ ns}$:	$\leq 1 \text{ ns}$

G.8 Electrostatic discharge

Mains voltage:	$\leq 0,2$ % of applied voltage
Mains frequency:	$\leq 0,2$ % of applied frequency
Applied voltage:	$\leq x^a$ % of peak voltage
Electrical charge:	$\leq x^a$ % of applied discharge

^a These uncertainty values were not available at the time of publication.

G.9 Electromagnetic interference

Voltage: $\leq 0,2$ % of applied voltage

Frequency: $\leq 0,2$ % of applied frequency

Sweep rate: $\leq 2,5 \times 10^{-4}$ octave/s

Field strength: $\leq 0,2$ % of applied field strength

Harmonic distortion: $\leq 0,2$ % of applied current

G.10 Mechanical vibration

Frequency: $\leq x^a$ Hz

Harmonic distortion: $\leq x^a$ % of [to be completed]

Acceleration: $\leq x^a$ m/s²

Linear displacement: $\leq x^a$ mm

Time (t): $\leq x^a$ s

^a These uncertainty values were not available at the time of publication.

Annex H (informative)

Pressure loss test pressure tapplings, hole and slot details

H.1 General

The pressure loss of a water meter may be determined from measurements of the differential pressure across a water meter at the stipulated flow rate. It is obtained using the method specified in [7.9](#).

H.2 Design of measuring section pressure tapplings

Pressure tapplings of similar design and dimensions should be fitted to the inlet and outlet pipes of the measuring section.

Pressure tapplings may consist of holes drilled through the pipe wall or may be in the form of an annular slit in the pipe wall, in either case perpendicular to the pipe axis. There should be at least four such pressure tapping holes, equally spaced in one plane around the pipe circumference.

Recommended designs for pressure tapplings are given in [Figures H.1](#), [H.2](#), and [H.3](#).

Other means such as a ring or balance chamber may also be used.

H.3 Pressure tapplings, hole and slit details

Holes drilled through the pipe wall should be perpendicular to the pipe axis. Tapplings should not be more than 4 mm or less than 2 mm in diameter. If the pipe diameter is less than or equal to 25 mm, the tapplings should be as close to 2 mm in diameter as possible. The diameter of the holes should remain constant for a distance of not less than twice the tapping diameter before breaking into the pipe. The holes drilled through the pipe wall should be free from burrs at the edges where they break through into the inlet and outlet pipe bores. The edges should be sharp: they should have neither a radius nor a chamfer.

Slits should be perpendicular to the pipe axis and should have dimensions as follows:

- width b equal to $0,08D$ but neither less than 2 mm nor greater than 4 mm;
- depth h greater than $2b$.

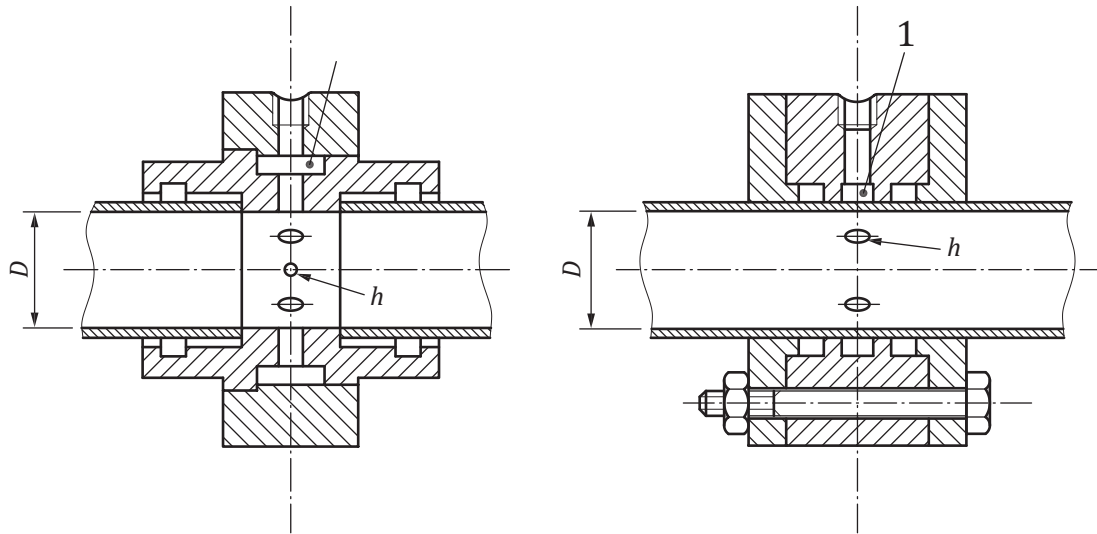

Key

1 ring chamber

Figure H.1 — Example of drilled hole type of pressure tapping with ring chamber, suitable for small/medium diameter test sections

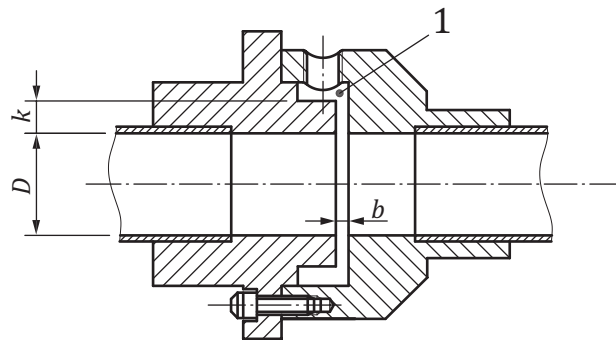

Key

1 ring chamber

Figure H.2 — Example of slit type of pressure tapping with ring chamber, suitable for small/medium diameter test sections

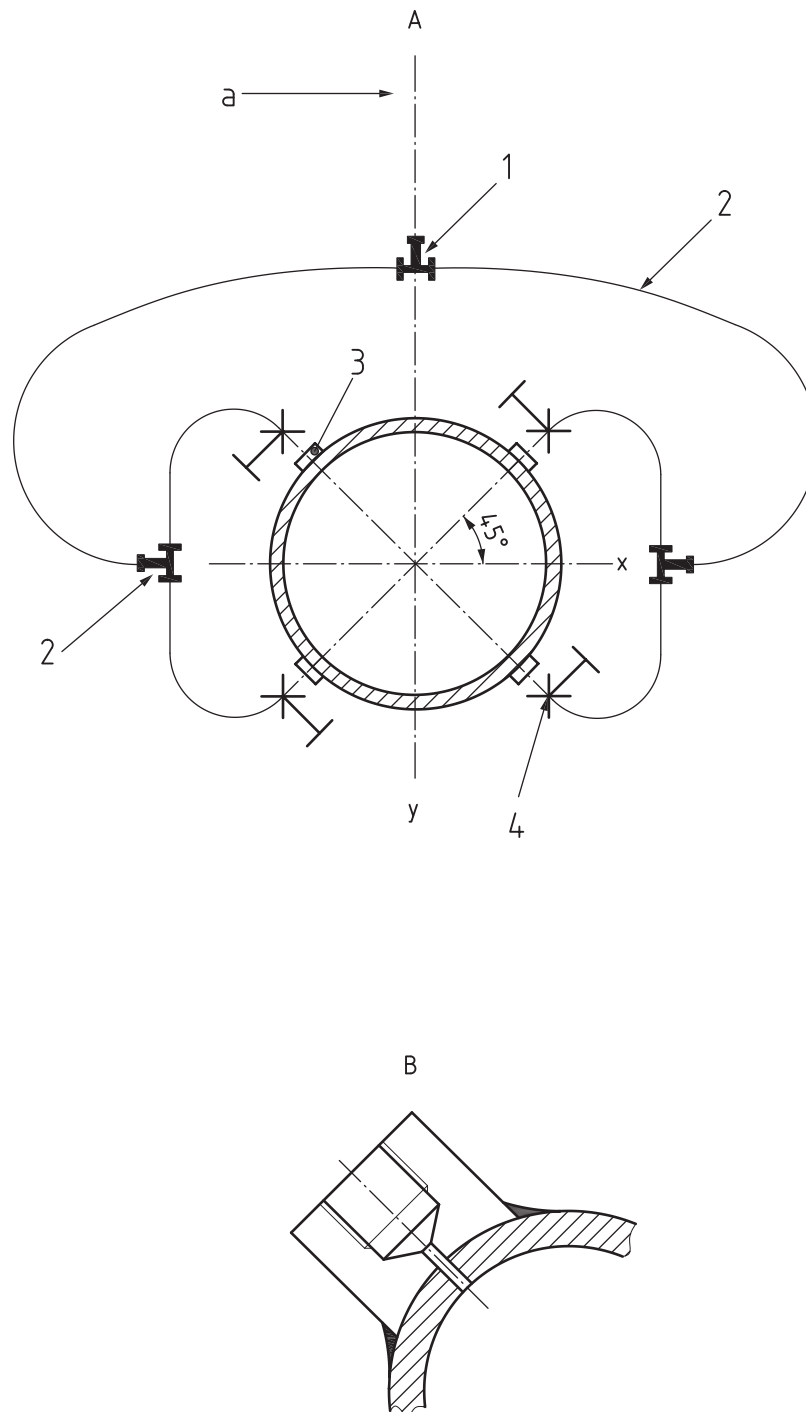

Key

- A cross-section through pipe and pressure tappings
- y vertical axis
- 1 tee
- 3 pressure tapping (see B)
- a To manometer.

- B detail of pressure tapping and boss
- x horizontal axis
- 2 flexible hose or copper pipe
- 4 isolating cock

Figure H.3 — Example of drilled hole type of pressure tapping with connections between tappings to give mean static pressure, suitable for medium or large diameter test sections

Annex I (normative)

Flow disturbers

I.1 General

Figures I.1 to I.12 show flow disturber types to be used in tests as specified in 7.10.

NOTE All dimensions shown in the drawings are in millimetres, unless otherwise stated.

Machined dimensions shall have a tolerance of $\pm 0,25$ mm unless otherwise stated.

I.2 Threaded type disturbance generators

Figure I.1 shows an arrangement of swirl generator units for a threaded type disturbance generator.

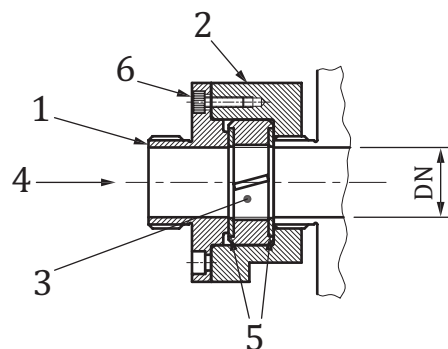

Key

Item	Description	Quantity	Material
1	cover	1	stainless steel
2	body	1	stainless steel
3	swirl generator	1	stainless steel
4	flow	—	—
5	gasket	2	fibre
6	hexagon socket head cap screw	4	stainless steel

Figure I.1 — Threaded type disturbance generator — Arrangement of swirl generator units: type 1 disturber — Sinistrorsal swirl generator; type 2 — Dextrorsal swirl generator

Figure I.2 shows an arrangement of velocity profile disturbance units for a threaded type disturbance generator.

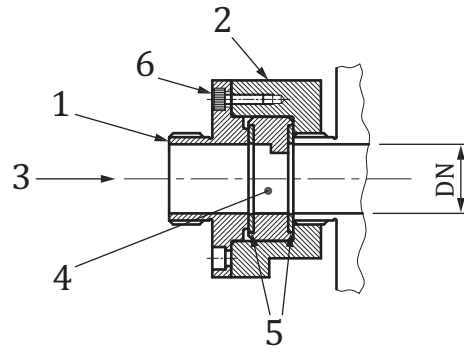

Key

Item	Description	Quantity	Material
1	cover	1	stainless steel
2	body	1	stainless steel
3	flow	—	—
4	flow disturber	1	stainless steel
5	gasket	2	fibre
6	hexagon socket head cap screw	4	stainless steel

Figure I.2 — Threaded type disturbance generator — Arrangement of velocity profile disturbance units: type 3 disturber — Velocity profile flow disturber

[Figure I.3](#) illustrates the cover of a threaded type disturbance generator, with dimensions as set out in [Table I.1](#).

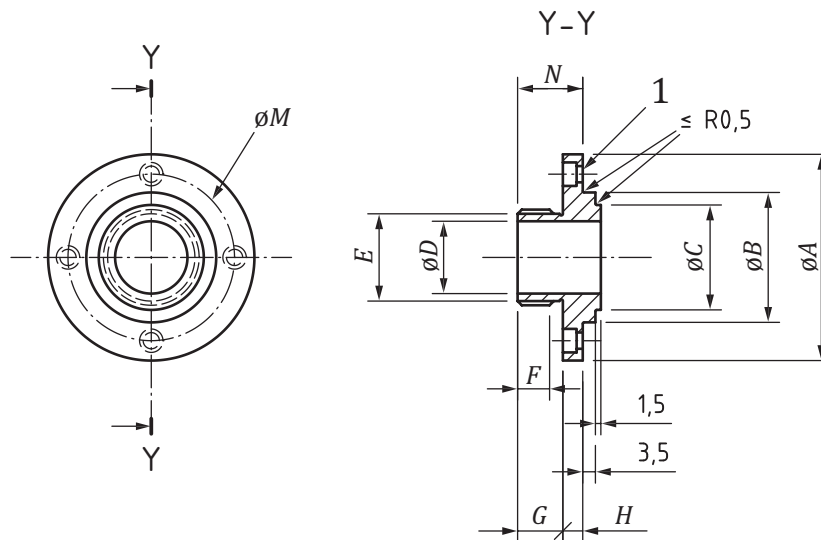

Key

1 4 holes ϕJ , bore $\phi K \times L$

Machined surface roughness 3,2 μm all over.

Figure I.3 — Cover for a threaded type disturbance generator, with dimensions as set out in [Table I.1](#)

Table I.1 — Dimensions for the cover (item 1) for a threaded type disturbance generator (see Figure I.3)

DN	A	B (e9 ^a)	C	D	E ^b	F	G	H	J	K	L	M	N
15	52	29,960 29,908	23	15	G 3/4 " B	10	12,5	5,5	4,5	7,5	4	40	23
20	58	35,950 35,888	29	20	G 1 " B	10	12,5	5,5	4,5	7,5	4	46	23
25	63	41,950 41,888	36	25	G 1 ¼ " B	12	14,5	6,5	5,5	9,0	5	52	26
32	76	51,940 51,866	44	32	G 1 ½ " B	12	16,5	6,5	5,5	9,0	5	64	28
40	82	59,940 59,866	50	40	G 2 " B	13	18,5	6,5	5,5	9,0	5	70	30
50	102	69,940 69,866	62	50	G 2 ½ " B	13	20,0	8,0	6,5	10,5	6	84	33

a See ISO 286-2.[2]
 b See ISO 228-1.[1]

Figure I.4 illustrates the body of a threaded type disturbance generator, with dimensions as set out in Table I.2.

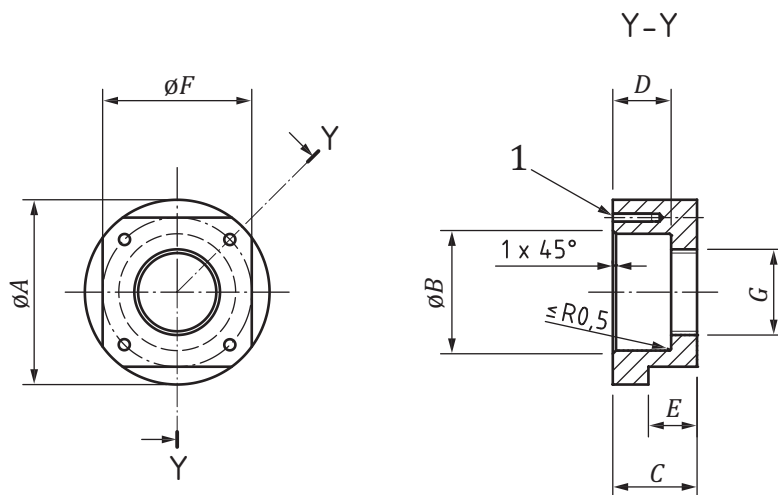

Key

1 4 holes $\phi H \times J$ deep. Tap K thread $\times L$

Machined surface roughness 3,2 μm all over.

Figure I.4 — Body of a threaded type disturbance generator, with dimensions as set out in Table I.2

Table I.2 — Dimensions for the body (item 2) of a threaded type disturbance generator (see Figure I.4)

DN	A	B (H9 ^a)	C	D	E	F	G	H	J	K	L	M
15	52	30,052 30,000	23,5	15,5	15	46	G ¾ " B	3,3	16	M4	12	40
20	58	36,062 36,000	26,0	18,0	15	46	G 1 " B	3,3	16	M4	12	46
25	63	42,062 42,000	30,5	20,5	20	55	G 1 ¼ " B	4,2	18	M5	14	52
32	76	52,074 52,000	35,0	24,0	20	65	G 1 ½ " B	4,2	18	M5	14	64
40	82	60,074 60,000	41,0	28,0	25	75	G 2 " B	4,2	18	M5	14	70
50	102	70,074 70,000	47,0	33,0	25	90	G 2 ½ " B	5,0	24	M6	20	84

^a See ISO 286-2.[2]

Figure I.5 illustrates the swirl generator of a threaded type disturbance generator, with dimensions as set out in Table I.3.

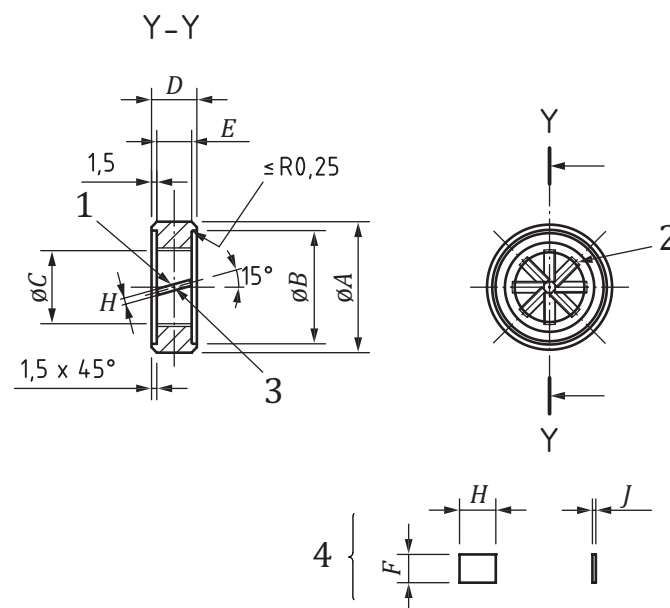

Key

- | | | | |
|---|---|---|-------------------------------|
| 1 | 8 slots equally spaced to locate blades | 3 | depth of slot at centre, 0,76 |
| 2 | locate blades in slots and welding | 4 | blade detail |
- Machined surface roughness 3,2 µm all over.

Figure I.5 — Swirl generator for a threaded type disturbance generator, with dimensions as set out in Table I.3

Table I.3 — Dimensions for the swirl generator (item 3) of a threaded type disturbance generator (see [Figure I.5](#))

DN	A (d10 ^a)	B	C	D	E	F	G	H	J
15	29,935 29,851	25	15	10,5	7,5	6,05	7,6	0,57 0,52	0,50
20	35,920 35,820	31	20	13,0	10,0	7,72	10,2	0,57 0,52	0,50
25	41,920 41,820	38	25	15,5	12,5	9,38	12,7	0,82 0,77	0,75
32	51,900 51,780	46	32	19,0	16,0	11,72	16,4	0,82 0,77	0,75
40	59,900 59,780	52	40	23,0	20,0	14,38	20,5	0,82 0,77	0,75
50	69,900 69,780	64	50	28,0	25,0	17,72	25,5	1,57 1,52	1,50

^a See ISO 286-2.[2]

[Figure I.6](#) illustrates the flow disturber of a threaded type disturbance generator, with dimensions as set out in [Table I.4](#).

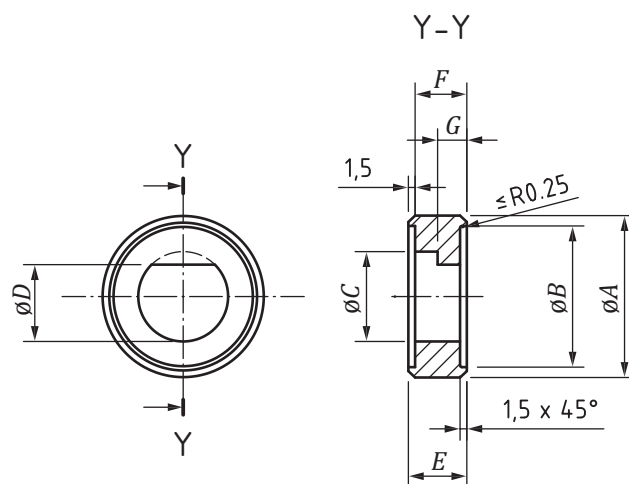

Figure I.6 — Flow disturber for a threaded type disturbance generator, with dimensions as set out in [Table I.4](#)

Table I.4 — Dimensions for the flow disturber (item 4) of a threaded type disturbance generator (see [Figure I.6](#))

DN	A (d10 ^a)	B	C	D	E	F	G
15	29,935 29,851	25	15	13,125	10,5	7,5	7,5
20	35,920 35,820	31	20	17,500	13,0	10,0	5,0
25	41,920 41,820	38	25	21,875	15,5	12,5	6,0
32	51,900 51,780	46	32	28,000	19,0	16,0	6,0
40	59,900 59,780	52	40	35,000	23,0	20,0	6,0
50	69,900 69,780	64	50	43,750	28,0	25,0	6,0

^a See ISO 286-2.[2]

[Figure I.7](#) illustrates the gasket of a threaded type disturbance generator, with dimensions as set out in [Table I.5](#).

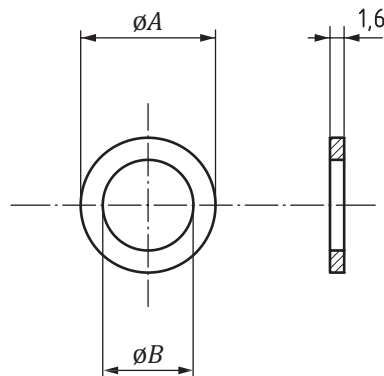
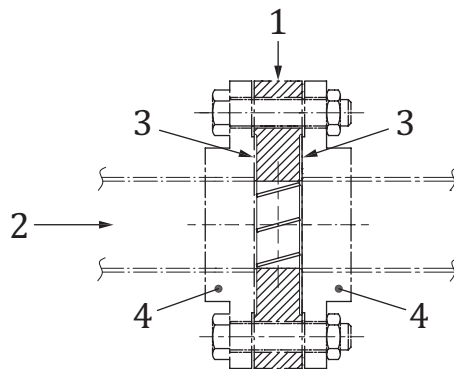

Figure I.7 — Gasket for a threaded type disturbance generator, with dimensions as set out in [Table I.5](#)

Table I.5 — Dimensions for the gasket (item 5) of a threaded type disturbance generator (see [Figure I.7](#))

DN	A	B
15	24,5	15,5
20	30,5	20,5
25	37,5	25,5
32	45,5	32,5
40	51,5	40,5
50	63,5	50,5

[Figure I.8](#) shows an arrangement of swirl generator units for a wafer type disturbance generator.



Key

Item	Description	Quantity	Material
1	swirl generator	1	stainless steel
2	flow	—	—
3	gasket	2	fibre
4	straight length with flange (ISO 7005-2[3] or ISO 7005-3[4])	4	stainless steel

Figure I.8 — Wafer type disturbance generators — Arrangement of swirl generator units: type 1 disturber — Swirl generator sinistrorsal; type 2 disturber — Swirl generator dextrorsal

Figure I.9 shows an arrangement of velocity profile disturbance units for a wafer type disturbance generator.

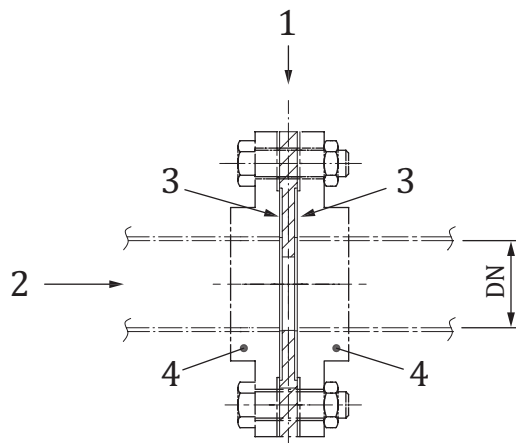

Key

Item	Description	Quantity	Material
1	flow disturber	1	stainless steel
2	flow	—	—
3	gasket	2	fibre
4	straight length with flange (ISO 7005-2[3] or ISO 7005-3[4])	4	stainless steel

Figure I.9 — Wafer type disturbance generator — Arrangement of velocity profile disturbance units: type 3 disturber — Velocity profile flow disturber

Figure I.10 illustrates the swirl generator of wafer type disturbance generator, with dimensions as set out in Table I.6.

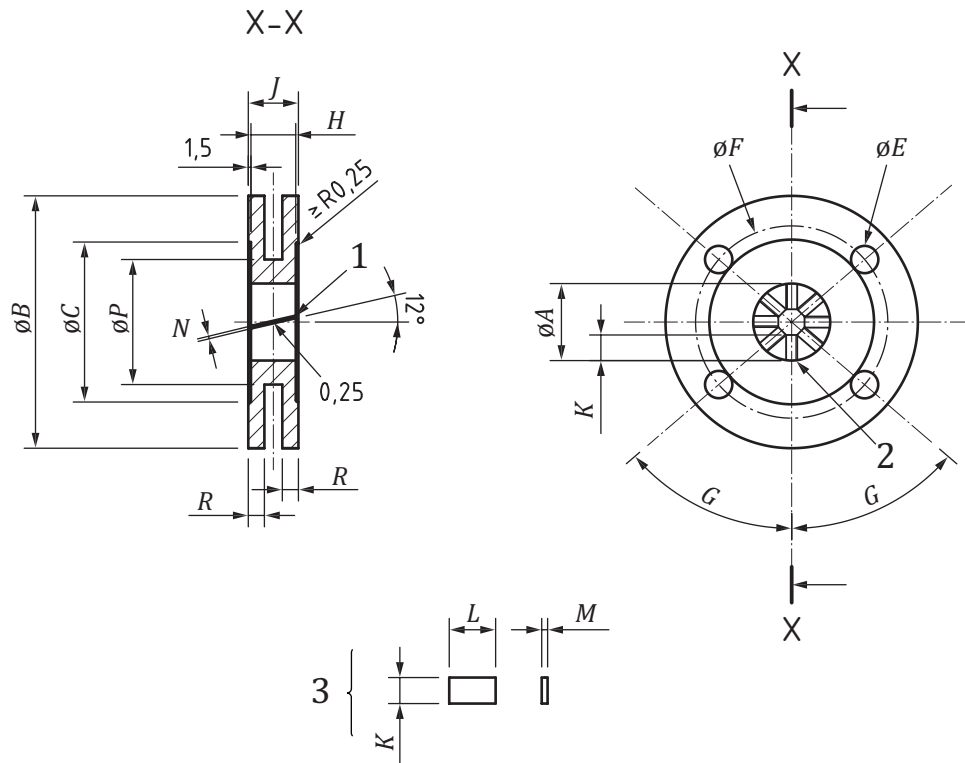

Key

- 1 8 slots equally spaced to locate blades 2 blades to be fixed in (welding) 3 blade detail

Figure I.10 — Swirl generator for wafer type disturbance generator, with dimensions as set out in Table I.6

**Table I.6 — Dimensions for the swirl generator (item 1) of a wafer type disturbance generator
 (see [Figure I.10](#))**

DN	A	B	C	D	E	F	G °	H	J	K	L	M	N	P	R
50	50	165	104	4	18	125	45	25	28	16,9	25,5	1,5	1,57 1,52	—	—
65	65	185	124	4	18	145	45	33	36	21,9	33,4	1,5	1,57 1,52	—	—
80	80	200	139	8	18	160	22 1/2	40	43	26,9	40,6	1,5	1,57 1,52	—	—
100	100	220	159	8	18	180	22 1/2	50	53	33,6	50,8	1,5	1,57 1,52	—	—
125	125	250	189	8	18	210	22 1/2	63	66	41,9	64,1	1,5	1,57 1,52	—	—
150	150	285	214	8	22	240	22 1/2	75	78	50,3	76,1	3,0	3,07 3,02	195	22
200	200	340	269	8	22	295	22 1/2	100	103	66,9	101,6	3,0	3,07 3,02	245	24
250	250	395	324	12	22	350	15	125	128	83,6	127,2	3,0	3,07 3,02	295	26
300	300	445	374	12	22	400	15	150	153	100,3	152,7	3,0	3,07 3,02	345	28
400	400	565	482	16	27	515	11 1/4	200	203	133,6	203,8	3,0	3,07 3,02	445	30
500	500	670	587	20	27	620	9	250	253	166,9	255,0	3,0	3,07 3,02	545	32
600	600	780	687	20	30	725	9	300	303	200,3	306,1	3,0	3,07 3,02	645	34
800	800	1015	912	24	33	950	7 1/2	400	403	266,9	408,3	3,0	3,07 3,02	845	36

[Figure I.11](#) illustrates the flow disturber of a wafer type disturbance generator, with dimensions as set out in [Table I.7](#).

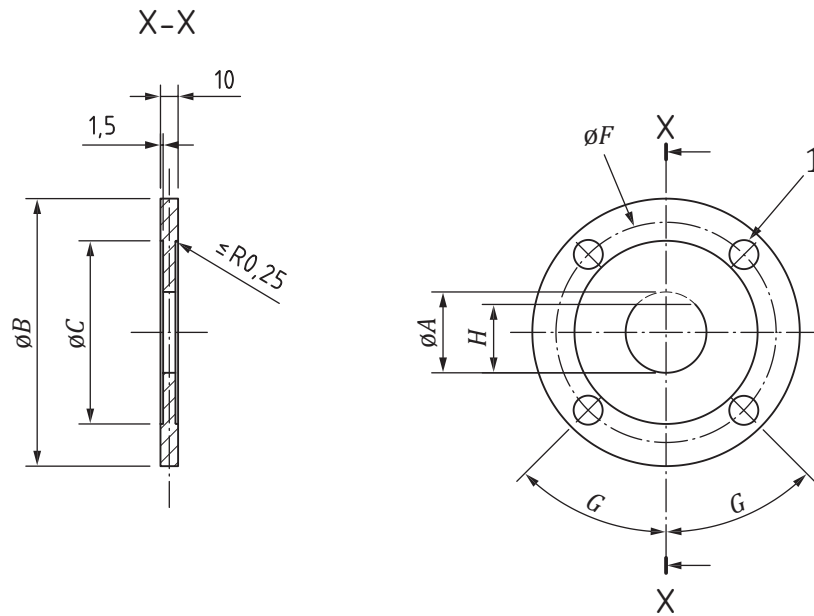

Key

1 D holes of ϕE

Machine surface tolerance $3,2 \mu\text{m}$ all over.

Figure I.11 — Flow disturber of a wafer type disturbance generator, with dimensions as set out in [Table I.7](#)

Table I.7 — Dimensions for flow disturber (item 2) of a wafer type disturbance generator (see [Figure I.11](#))

DN	A	B	C	D	E	F	G	H
50	50	165	104	4	18	125	45	43,8
65	65	185	124	4	18	145	45	56,9
80	80	200	139	8	18	160	22 1/2	70,0
100	100	220	159	8	18	180	22 1/2	87,5
125	125	250	189	8	18	210	22 1/2	109,4
150	150	285	214	8	22	240	22 1/2	131,3
200	200	340	269	8	22	295	22 1/2	175,0
250	250	395	324	12	22	350	15	218,8
300	300	445	374	12	22	400	15	262,5
400	400	565	482	16	27	515	11 1/4	350,0
500	500	670	587	20	27	620	9	437,5
600	600	780	687	20	30	725	9	525,0
800	800	1015	912	24	33	950	7 1/2	700,0

[Figure I.12](#) illustrates the gasket of a wafer type disturbance generator, with dimensions as set out in [Table I.8](#).

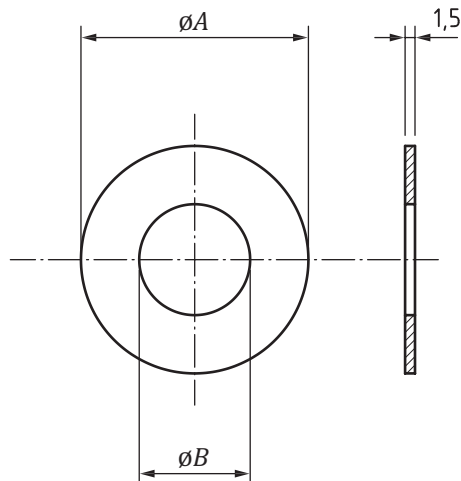

Figure I.12 — Gasket of a wafer type disturbance generator, with dimensions as set out in [Table I.8](#)

Table I.8 — Dimensions for the gasket (item 3) of a wafer type disturbance generator (see [Figure I.12](#))

DN	A	B
50	103,5	50,5
65	123,5	65,5
80	138,5	80,5
100	158,5	100,5
125	188,5	125,5
150	213,5	150,5
200	268,5	200,5
250	323,5	250,5
300	373,5	300,5
400	481,5	400,5
500	586,5	500,5
600	686,5	600,5
800	911,5	800,5

Bibliography

- [1] ISO 228-1, *Pipe threads where pressure-tight joints are not made on the threads — Part 1: Dimensions, tolerances and designation*
- [2] ISO 286-2, *Geometrical product specifications (GPS) — ISO code system for tolerances on linear sizes — Part 2: Tables of standard tolerance classes and limit deviations for holes and shafts*
- [3] ISO 7005-2, *Metallic flanges — Part 2: Cast iron flanges*
- [4] ISO 7005-3, *Metallic flanges — Part 3: Copper alloy and composite flanges*
- [5] IEC 60068-3-1, *Environmental testing — Part 3-1: Supporting documentation and guidance — Cold and dry heat tests*
- [6] OIML B 3:2003, OIML Certificate system for measuring instruments
- [7] WAGNER W., & PRUSS A. The IAPWS formulation 1995 for the thermodynamic properties of ordinary water substance for general and scientific use. *J. Phys. Chem. Ref. Data.* 2002, **31** pp. 387–535
- [8] WAGENBRETH H., & BLANKE W. Die Dichte des Wassers im Internationalen Einheitensystem und in der Internationalen Praktischen Temperaturskala von 1968 [The density of water in the International System of Units and the International Practical Temperature Scale of 1968]. *PTB Mitteilungen* 1971, **81**, pp. 412–415
BETTIN H.F., & SPIEWECK F Die Dichte des Wassers als Funktion der Temperatur nach Einführung der Internationalen Temperaturskala von 1990 [The density of water as a function of temperature after the introduction of the International Temperature Scale of 1990]. *PTB Mitteilungen.* 1990, **100** pp. 195–196
- [9] PATTERSON J.C., & MORRIS E.C. Measurement of absolute water density, 1 °C to 40 °C. *Metrologia.* 1994, **31** pp. 277–288
- [10] TANAKA M., GIRARD G., DAVIS R., PEUTO A., BIGNELL N. Recommended table for the density of water between 0 °C and 40 °C based on recent experimental reports. *Metrologia.* 2001, **38** pp. 301–309
- [11] ISO 5167-1:2003, *Measurement of fluid flow by means of pressure differential devices inserted in circular cross-section conduits running full — Part 1: General principles and requirements.*
- [12] IEC 60068-1, *Environmental testing — Part 1: General and guidance*

British Standards Institution (BSI)

BSI is the national body responsible for preparing British Standards and other standards-related publications, information and services.

BSI is incorporated by Royal Charter. British Standards and other standardization products are published by BSI Standards Limited.

About us

We bring together business, industry, government, consumers, innovators and others to shape their combined experience and expertise into standards-based solutions.

The knowledge embodied in our standards has been carefully assembled in a dependable format and refined through our open consultation process. Organizations of all sizes and across all sectors choose standards to help them achieve their goals.

Information on standards

We can provide you with the knowledge that your organization needs to succeed. Find out more about British Standards by visiting our website at bsigroup.com/standards or contacting our Customer Services team or Knowledge Centre.

Buying standards

You can buy and download PDF versions of BSI publications, including British and adopted European and international standards, through our website at bsigroup.com/shop, where hard copies can also be purchased.

If you need international and foreign standards from other Standards Development Organizations, hard copies can be ordered from our Customer Services team.

Subscriptions

Our range of subscription services are designed to make using standards easier for you. For further information on our subscription products go to bsigroup.com/subscriptions.

With **British Standards Online (BSOL)** you'll have instant access to over 55,000 British and adopted European and international standards from your desktop. It's available 24/7 and is refreshed daily so you'll always be up to date.

You can keep in touch with standards developments and receive substantial discounts on the purchase price of standards, both in single copy and subscription format, by becoming a **BSI Subscribing Member**.

PLUS is an updating service exclusive to BSI Subscribing Members. You will automatically receive the latest hard copy of your standards when they're revised or replaced.

To find out more about becoming a BSI Subscribing Member and the benefits of membership, please visit bsigroup.com/shop.

With a **Multi-User Network Licence (MUNL)** you are able to host standards publications on your intranet. Licences can cover as few or as many users as you wish. With updates supplied as soon as they're available, you can be sure your documentation is current. For further information, email bsmusales@bsigroup.com.

BSI Group Headquarters

389 Chiswick High Road London W4 4AL UK

Revisions

Our British Standards and other publications are updated by amendment or revision.

We continually improve the quality of our products and services to benefit your business. If you find an inaccuracy or ambiguity within a British Standard or other BSI publication please inform the Knowledge Centre.

Copyright

All the data, software and documentation set out in all British Standards and other BSI publications are the property of and copyrighted by BSI, or some person or entity that owns copyright in the information used (such as the international standardization bodies) and has formally licensed such information to BSI for commercial publication and use. Except as permitted under the Copyright, Designs and Patents Act 1988 no extract may be reproduced, stored in a retrieval system or transmitted in any form or by any means – electronic, photocopying, recording or otherwise – without prior written permission from BSI. Details and advice can be obtained from the Copyright & Licensing Department.

Useful Contacts:

Customer Services

Tel: +44 845 086 9001

Email (orders): orders@bsigroup.com

Email (enquiries): cservices@bsigroup.com

Subscriptions

Tel: +44 845 086 9001

Email: subscriptions@bsigroup.com

Knowledge Centre

Tel: +44 20 8996 7004

Email: knowledgecentre@bsigroup.com

Copyright & Licensing

Tel: +44 20 8996 7070

Email: copyright@bsigroup.com



...making excellence a habit.™