

Fasteners — Electroplated coatings

The European Standard EN ISO 4042:1999 has the status of a
British Standard

ICS 21.060.01; 25.220.40

NO COPYING WITHOUT BSI PERMISSION EXCEPT AS PERMITTED BY COPYRIGHT LAW



National foreword

This British Standard is the official English language version of EN ISO 4042:1999. It is identical with ISO 4042:1999.

The UK participation in its preparation was entrusted by Technical Committee FME/9, Bolts, nuts and accessories, to Subcommittee FME/9/1, Mechanical properties of fasteners, which has the responsibility to:

- aid enquirers to understand the text;
- present to the responsible European committee any enquiries on the interpretation, or proposals for change, and keep the UK interests informed;
- monitor related international and European developments and promulgate them in the UK.

A list of organizations represented on this subcommittee can be obtained on request to its secretary.

Cross-references

Attention is drawn to the fact that CEN and CENELEC Standards normally include an annex which lists normative references to international publications with their corresponding European publications. The British Standards which implement international or European publications referred to in this document may be found in the BSI Standards Catalogue under the section entitled "International Standards Correspondence Index", or by using the "Find" facility of the BSI Standards Electronic Catalogue.

A British Standard does not purport to include all the necessary provisions of a contract. Users of British Standards are responsible for their correct application.

Compliance with a British Standard does not of itself confer immunity from legal obligations.

Summary of pages

This document comprises a front cover, an inside front cover, the EN ISO title page, the EN ISO foreword page, the ISO title page, pages ii and iii, a blank page, pages 1 to 23, the annex ZA page, an inside back cover and a back cover.

The BSI copyright notice displayed in this document indicates when the document was last issued.

This British Standard, having been prepared under the direction of the Engineering Sector Committee, was published under the authority of the Standards Committee and comes into effect on 15 May 2000

© BSI 05-2000

Amendments issued since publication

Amd. No.	Date	Comments

ISBN 0 580 34867 9

EUROPEAN STANDARD
NORME EUROPÉENNE
EUROPÄISCHE NORM

EN ISO 4042

June 1999

ICS 21.060.10

English version

Fasteners - Electroplated coatings (ISO 4042:1999)

Eléments de fixation - Revêtements électrolytiques (ISO
4042:1999)

Verbindungselemente - Galvanische Überzüge (ISO
4042:1999)

This European Standard was approved by CEN on 26 May 1999.

CEN members are bound to comply with the CEN/CENELEC Internal Regulations which stipulate the conditions for giving this European Standard the status of a national standard without any alteration. Up-to-date lists and bibliographical references concerning such national standards may be obtained on application to the Central Secretariat or to any CEN member.

This European Standard exists in three official versions (English, French, German). A version in any other language made by translation under the responsibility of a CEN member into its own language and notified to the Central Secretariat has the same status as the official versions.

CEN members are the national standards bodies of Austria, Belgium, Czech Republic, Denmark, Finland, France, Germany, Greece, Iceland, Ireland, Italy, Luxembourg, Netherlands, Norway, Portugal, Spain, Sweden, Switzerland and United Kingdom.



EUROPEAN COMMITTEE FOR STANDARDIZATION
COMITÉ EUROPÉEN DE NORMALISATION
EUROPÄISCHES KOMITEE FÜR NORMUNG

Central Secretariat: rue de Stassart, 36 B-1050 Brussels

Corrected 99-09-16

Foreword

The text of the International Standard from Technical Committee ISO/TC 2 "Fasteners" of the International Organization for Standardization (ISO) has been taken over as an European Standard by Technical Committee CEN/TC 185 "Threaded and non-threaded mechanical fasteners and accessories", the secretariat of which is held by national standard body.

This European Standard shall be given the status of a national standard, either by publication of an identical text or by endorsement, at the latest by December 1999, and conflicting national standards shall be withdrawn at the latest by December 1999.

According to the CEN/CENELEC Internal Regulations, the national standards organizations of the following countries are bound to implement this European Standard: Austria, Belgium, Czech Republic, Denmark, Finland, France, Germany, Greece, Iceland, Ireland, Italy, Luxembourg, Netherlands, Norway, Portugal, Spain, Sweden, Switzerland and the United Kingdom.

Endorsement notice

The text of the International Standard ISO 4042:1999 has been approved by CEN as a European Standard without any modification.

NOTE: Normative references to International Standards are listed in annex ZA (normative).

INTERNATIONAL STANDARD

ISO 4042

Second edition
1999-06-15

Fasteners — Electroplated coatings

Éléments de fixation — Revêtements électrolytiques



Reference number
ISO 4042:1999(E)

ISO 4042:1999(E)

Contents	Page
1 Scope	1
2 Normative references	1
3 Terms and definitions	2
4 Dimensional requirements and gauging	3
4.1 Dimensional requirements before electroplating	3
4.2 Dimensional requirements after electroplating	3
5 Other coating requirements	3
6 Hydrogen embrittlement relief	3
7 Corrosion protection	4
8 Applicability to fasteners that cut or form their own mating threads	4
9 Specification of coating thickness	4
10 Measurement of coating thickness	5
10.1 Local thickness	5
10.2 Batch average thickness	7
10.3 Agreement on test method	7
11 Sampling for thickness tests	7
12 Ordering requirements for electroplating	7
13 Designation	7
Annex A (informative) Hydrogen embrittlement relief	8
Annex B (informative) Salt spray corrosion protection performance of metallic coatings	10
Annex C (informative) Guidance on procedures that may be adopted to accommodate thick coatings	12
Annex D (normative) Determination of batch average thickness	13
Annex E (normative) Designation code, system A, for electroplated coatings on threaded parts	16
Annex F (informative) Examples for coating designation	19
Annex G (informative) Surface areas of bolts, screws and nuts	20
Bibliography	23

Foreword

ISO (the International Organization for Standardization) is a worldwide federation of national standards bodies (ISO member bodies). The work of preparing International Standards is normally carried out through ISO technical committees. Each member body interested in a subject for which a technical committee has been established has the right to be represented on that committee. International organizations, governmental and non-governmental, in liaison with ISO, also take part in the work. ISO collaborates closely with the International Electrotechnical Commission (IEC) on all matters of electrotechnical standardization.

International Standards are drafted in accordance with the rules given in the ISO/IEC Directives, Part 3.

Draft International Standards adopted by the technical committees are circulated to the member bodies for voting. Publication as an International Standard requires approval by at least 75 % of the member bodies casting a vote.

International Standard ISO 4042 was prepared by Technical Committee ISO/TC 2, *Fasteners*, Subcommittee SC1, *Mechanical properties of fasteners*.

This second edition cancels and replaces the first edition (ISO 4042:1989) which has been technically revised.

Annexes D and E form a normative part of this International Standard. Annexes A, B, C, F and G are for information only.

Fasteners — Electroplated coatings

1 Scope

This International Standard specifies dimensional requirements for electroplated fasteners of steel or copper alloy. It specifies coating thicknesses and gives recommendations for hydrogen embrittlement relief for fasteners with high tensile strength or hardness and for surface-hardened fasteners.

This International Standard primarily concerns the electroplating of threaded fasteners, but it may also be applied to other threaded parts. For the applicability to screws that cut or form their own mating threads, see clause 8.

The specifications given in this International Standard may also be applied to non-threaded parts such as washers and pins.

2 Normative references

The following normative documents contain provisions which, through reference in this text, constitute provisions of this International Standard. For dated references, subsequent amendments to, or revisions of, any of these publications do not apply. However, parties to agreements based on this International Standard are encouraged to investigate the possibility of applying the most recent editions of the normative documents indicated below. For undated references, the latest edition of the normative document referred to applies. Members of ISO and IEC maintain registers of currently valid International Standards.

ISO 965-1:1999, *ISO general purpose metric screw threads — Tolerances — Part 1: Principles and basic data.*

ISO 965-2:1999, *ISO general purpose metric screw threads — Tolerances — Part 2: Limits of sizes for general purpose bolt and nut threads — Medium quality.*

ISO 965-3:1999, *ISO general purpose metric screw threads — Tolerances — Part 3: Deviations for constructional threads.*

ISO 1456:1988, *Metallic coatings — Electrodeposited coatings of nickel plus chromium and of copper plus nickel plus chromium.*

ISO 1458:1988, *Metallic coating — Electrodeposited coatings of nickel.*

ISO 1502:1996, *ISO general purpose metric screw threads — Gauges and gauging.*

ISO 2064:1996, *Metallic and other non-organic coatings — Definitions and conventions concerning the measurement of thickness.*

ISO 2081:1986, *Metallic coatings — Electroplated coatings of zinc on iron or steel.*

ISO 2082:1986, *Metallic coatings — Electroplated coatings of cadmium on iron or steel.*

ISO 4042:1999(E)

ISO 3269:—¹⁾, *Fasteners — Acceptance inspection.*

ISO 4520:1981, *Chromate conversion coatings on electroplated zinc and cadmium coatings.*

ISO 9227:1990, *Corrosion tests in artificial atmospheres — Salt spray tests.*

ISO 9587:—²⁾, *Metallic and other inorganic coatings — Pre-treatments of iron or steel for reducing the risk of hydrogen embrittlement.*

ISO 15330:—²⁾, *Fasteners — Preloading test for the detection of hydrogen embrittlement — Parallel bearing surface method.*

3 Terms and definitions

For the purposes of this International Standard, the definitions given in ISO 2064 (in particular, the definitions of significant surface, measuring area, local thickness and minimum local thickness) and ISO 3269 together with the following, apply.

3.1**batch**

quantity of identical fasteners from the same manufacturing lot processed together at one time

3.2**production run**

those batches of parts processed continuously without any changes in coating techniques or constituents

3.3**batch average thickness**

calculated average thickness of a coating if it was uniformly distributed over the surface of the parts of the batch

3.4**baking**

process of heating parts for a definite time at a given temperature in order to minimize the risk of hydrogen embrittlement

3.5**baking duration**

time at which the parts are held at the specified temperature which they shall have completely reached

1) To be published. (Revision of ISO 3269:1988)

2) To be published.

4 Dimensional requirements and gauging

4.1 Dimensional requirements before electroplating

Before coating, parts shall comply with the relevant International Standards if applicable or other standards as specified, except where threads or other features are specifically manufactured to allow, for functional reasons, the application of thicker coatings than are possible on normal threads.

Coating thicknesses which can be applied on ISO metric threads in accordance with ISO 965-1, ISO 965-2 and ISO 965-3 depend on the fundamental deviation available, which itself depends on the screw thread and the following tolerance positions:

- g, f, e for external threads;
- G for internal threads or H if required.

The tolerance positions apply prior to application of the electroplated coating.

4.2 Dimensional requirements after electroplating

After coating, ISO metric screw threads shall be gauged in accordance with ISO 1502 with a GO gauge of tolerance position h for external threads and H for internal threads.

Other product dimensions apply only before coating.

NOTE Care should be exercised where relatively thick coatings may affect dimensions with small tolerances as in the case of internal drives; in these cases an agreement should be made between the supplier and the purchaser.

The applicability of the recommended coatings to ISO metric threads is limited by the fundamental deviation of the threads concerned and hence, by the pitch and tolerance positions. The coating shall not cause the zero line (basic size) to be exceeded in the case of external threads, nor shall it fall below this line in the case of internal threads. This means that for an internal thread of tolerance position H, a measurable coating thickness can only be applied to the threads if the tolerance zone is not taken up to the zero line (basic size).

5 Other coating requirements

The electroplated coating shall comply with the provisions of the relevant International Standards (ISO 1456, ISO 1458, ISO 2081, ISO 2082) for the coating concerned in respect of appearance, adhesion, ductility, corrosion resistance, etc.

6 Hydrogen embrittlement relief

In cases of parts

- with high tensile strength or hardness or which have been surface hardened,
- which have absorbed hydrogen and
- are under tensile stress

there is the risk of failure due to hydrogen embrittlement.

When the core or surface hardness is above 320 HV, process investigation shall be conducted using a test to detect hydrogen embrittlement, for example the "Parallel bearing surface method" in accordance with ISO 15330, to be sure that the process with regard to embrittlement is under control. If embrittlement is discovered, modification of the manufacturing process will be necessary, such as the inclusion of a baking process (see informative annex A for more information).

ISO 4042:1999(E)

For fasteners of hardness in excess of 365 HV, a written agreement should exist between the customer and manufacturer to define how to manage the risk. If written agreement does not exist, the manufacturer shall process the parts in accordance with his recommended practices to reduce the risk of hydrogen embrittlement.

Complete elimination of hydrogen embrittlement cannot be assured. If a reduced probability of encountering hydrogen embrittlement is desired, alternative procedures should be evaluated.

NOTE Investigations are proceeding to develop methods for the reduction of hydrogen embrittlement.

7 Corrosion protection

The corrosion protection of an electroplated coating depends to a considerable extent on its thickness. In addition to greater coating thickness, a chromate conversion treatment can be specified for increased corrosion protection on zinc and cadmium coatings.

Contact with other metals and materials, the frequency and duration of wetting and service temperatures may influence the protective performance of coatings and expert advice is essential when uncertainties of choice arise.

Coatings of Zn and Cd applied to ferrous substrates are less electropositive than the steel base metal and consequently provide cathodic protection. In contrast, Ni and Cr coatings are more electropositive than the steel base metal and may intensify part corrosion where the coating is damaged or pitted.

Cadmium coatings are dealt with in ISO 2082.

Zinc coatings are dealt with in ISO 2081.

Nickel coatings are dealt with in ISO 1458.

Nickel + chromium and copper + nickel + chromium coatings are dealt with in ISO 1456.

Chromate conversion treatments are dealt with in ISO 4520.

NOTE Information on salt spray corrosion protection performance of metallic coatings is given in informative annex B.

8 Applicability to fasteners that cut or form their own mating threads

All recommended coatings may be applied to screws that cut or form their own mating threads such as wood screws, self tapping screws, self drilling screws and thread forming screws. The maximum value for batch average thickness given in Table 1 may be ignored unless otherwise specified.

9 Specification of coating thickness

The local and batch average thicknesses corresponding to the nominal coating thicknesses recommended in the relevant International Standards for electroplating are given in Table 1.

In order to reduce the risk of interference on assembly of threads with electroplated coatings, the coating thickness shall not exceed one-quarter of the fundamental deviation of the thread. These values are specified in Table 2.

NOTE For accommodation of thick coatings guidance is given in informative annex C.

The effective coating thicknesses measured according to one of the methods specified in clause 10 shall comply with the values specified in Table 1.

Table 1 — Coating thicknesses

Thicknesses in micrometres

Nominal coating thickness	Effective coating thickness		
	Local ^a min.	Batch average ^b	
		min.	max.
3	3	3	5
5	5	4	6
8	8	7	10
10	10	9	12
12	12	11	15
15	15	14	18
20	20	18	23
25	25	23	28
30	30	27	35

^a For measuring local thickness see 10.1.
^b For measuring batch average thickness see 10.2.

In the case of batch average thickness measurement and if the threaded parts have nominal lengths $l > 5d$, smaller nominal thicknesses than those specified in Table 1 shall be applied, see Table 2.

10 Measurement of coating thickness

10.1 Local thickness

The local thickness shall be not less than the minimum thickness specified in the order, and shall be measured using one of the methods specified in the International Standard for the coating being applied. Thicknesses on bolts, screws and nuts shall only be measured on the test surfaces shown in Figure 1.

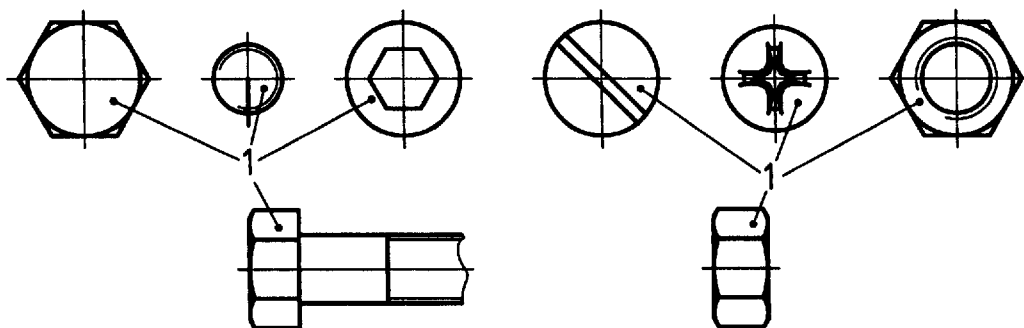

Key

1 Measurement area

Figure 1 — Measuring area for local coating thickness measurement on fasteners

10.2 Batch average thickness

Batch average thickness shall be measured by the method described in normative annex D. Exceeding the maximum batch average thickness shall not cause rejection if the coated thread is accepted by an appropriate GO gauge (H or h).

10.3 Agreement on test method

Unless otherwise specified, local thickness shall be measured.

NOTE Most screws and bolts are electroplated in bulk in barrels and as a consequence the greatest coating thickness is always at both extremities of the parts. This effect is increased the longer the screw or bolt is in relation to its diameter and tends to reduce the coating thickness that can be accepted by a specified pitch size.

11 Sampling for thickness tests

Sampling for thickness measurement shall be carried out in accordance with the requirements of ISO 3269.

12 Ordering requirements for electroplating

When ordering threaded components to be electroplated in accordance with this International Standard, the following information shall be supplied to the electroplater:

- a) The coating designation and, if required, the International Standard for the desired coating.
- b) The material of the part and its condition, e.g. heat treatment, hardness or other properties, which may be affected by the coating process.
- c) The stress relieving conditions, if any, for stress relieving prior to electroplating.
- d) The requirement, if any, for precautions to be taken against the risk of hydrogen embrittlement (see clause 6).
- e) Preference, if any, for batch average thickness measurement (see clause 10).
- f) Any requirement for selective electroplating or reduction of thread dimensions.
- g) Reference to the brightness or dullness; unless otherwise specified, bright finish shall be supplied.
- h) Supplementary coating requirements, for example subsequent lubrication.

13 Designation

Fasteners shall be specified according to the appropriate product standards. The designation of the surface coating shall be added to the product designation according to the specification of ISO 8991^[1] and shall be in accordance with

- System A: see code system in normative annex E or
- System B: see coating classification code described in ISO 1456 (nickel-chromium and copper-nickel-chromium), ISO 2081 (zinc), ISO 2082 (cadmium) and ISO 4520 (chromate conversion coatings).

For examples of coating designations, see informative annex F.

Annex A (informative)

Hydrogen embrittlement relief

A.1 Introduction

NOTE 1 The following two paragraphs are essentially the text of the introduction of ISO 9588:—³ (see^[2]).

When atomic hydrogen enters steels and certain other metals, for example aluminium and titanium alloys, it can cause loss of ductility or load carrying ability, cracking (usually as submicroscopic cracks) or catastrophic brittle failures at applied stresses well below the yield strength or even the normal design strength for the alloys. This phenomenon often occurs in alloys that show no significant loss in ductility when measured by conventional tensile tests, and is frequently referred to as hydrogen induced delayed brittle failure, hydrogen stress cracking or hydrogen embrittlement. The hydrogen can be introduced during heat treatment, gas carburizing, cleaning, pickling, phosphating, electroplating, autocatalytic processes and in the service environment as a result of cathodic protection reactions or corrosion reactions. Hydrogen can also be introduced during fabrication, for example during roll forming, machining and drilling due to the break-down of unsuitable lubricants as well as during welding or brazing operations. Parts that have been machined, ground, cold-formed or cold-straightened subsequent to hardening heat treatment are especially susceptible to hydrogen embrittlement damage.

The results of research work indicate that the susceptibility of any material to hydrogen embrittlement in a given test is directly related to its hydrogen entrapment population (type and effectiveness of traps). Therefore the time-temperature relationship of the baking process is dependent on composition and structure of steels as well as plating metals and plating procedures. Additionally, for most high strength steels, the effectiveness of the baking process falls off rapidly with reduction of time and temperature.

NOTE 2 "Traps" refer to certain metallurgical sites within the steel structure, such as inclusions, foreign atoms, dislocations, etc., to which atomic hydrogen may bond. Hydrogen thus bonded is no longer free to migrate to areas of high stress and contribute to the initiation of embrittlement fracture. Traps may be of the reversible or non-reversible type. For further information see Professor Troiano's paper^[3].

There are many reasons why a fastener may become embrittled. The total manufacturing process has to be controlled in such a way that the probability of embrittlement will be reduced to a minimum. This annex gives examples of procedures by which the probability of hydrogen embrittlement can be reduced during the manufacturing process for electroplating of fasteners.

A.2 Stress relief

Fasteners which have been cold worked hardened to 320 HV or above and are to be electroplated may benefit from a stress relieving process. This process should be carried out before application of the cleaning process defined in A.3. The temperature and duration applicable to the process will vary according to the design, manufacturing and heat treatment conditions of the parts concerned, and shall be notified to the coater, if the process is required in accordance with clause 12. Parts with a hardness above 320 HV that have been machined, ground, cold-formed or cold-straightened subsequent to heat treatment should be treated according to ISO 9587.

Stress relief may not be desirable in cases where residual stresses are intentionally introduced, for example, screws which are thread rolled after heat treatment.

A.3 Cleaning processes

Hydrogen absorption of the steel, leading to brittle failure after electroplating, may be induced by the cleaning process.

Unless otherwise agreed, parts heat-treated or work-hardened to a hardness of 320 HV or above should be cleaned with an inhibited acid, alkaline or mechanical process. Immersion time in the inhibited acid depends on the as-received surface condition and should be of minimum duration.

NOTE Inhibited acid is an acid to which a suitable inhibitor has been added to reduce corrosive attack on the steel and absorption of hydrogen.

Parts heat treated or cold worked to a hardness greater than 385 HV or property class 12.9 and above, should not be subjected to acid cleaning treatment. Special pre-treatments are advisable using non-acidic methods such as dry honing, abrasive blasting or alkali derusting.

Steel parts should be supplied with a surface which can be prepared for electroplating with a minimum immersion time for cleaning.

A.4 Plating process

For fasteners heat-treated or cold-worked to a hardness greater than 365 HV high cathodic efficiency electroplating solutions are advisable.

A.5 Baking process

With increasing hardness, increasing degree of cold working and increasing content of carbon and/or certain other elements of steel parts, the solubility of hydrogen and therefore the amount of absorbed hydrogen during an acid cleaning or electroplating process increases. At the same time, the critical amount of hydrogen which may cause brittle fracture decreases.

The beneficial effect of a baking process after electroplating is removal of hydrogen by effusion and/or irreversible trapping of hydrogen in the steel.

Parts should be baked within 4 h and preferably within an hour of electroplating and before chromating, to a part temperature of 200 °C to 230 °C. The maximum temperature should take into account the coating material and type of base material. Certain coatings, e.g. tin, and the physical properties of some parts, may be adversely affected by these temperatures. In such cases, lower temperatures and longer temper durations will be required. This should be agreed between purchaser and supplier.

With increasing coating thickness the difficulty of removing hydrogen increases. The introduction of an intermediate baking process when the coating is only 2 µm to 5 µm thick may reduce the risk of hydrogen embrittlement.

The user may agree that other conditions for embrittlement reduction may be used provided they can be shown to be effective.

It should not be assumed that the baking recommended will completely prevent hydrogen embrittlement in all cases. Alternative baking times and temperatures may be used if they have been shown to be effective for a part, but parts should not be baked at a temperature above the temperature at which the parts were originally tempered. Generally, lower baking temperatures require longer times at temperature. The chemical composition of some steels, in combination with process conditions, may produce a higher susceptibility to hydrogen embrittlement. Fasteners with larger diameters are less susceptible than those with small diameters.

At the time of publication of this International Standard it was not considered possible to give exact baking durations. Eight hours is considered a typical example of baking duration. However, baking durations in the range of 2 h to 24 h at 200 °C to 230 °C may be suitable according to the type and size of part, part geometry, mechanical properties, cleaning processes and electroplating processes used.

Annex B (informative)

Salt spray corrosion protection performance of metallic coatings

This annex gives information on the salt spray corrosion protection performance of zinc and cadmium coatings with chromate treatment (see Tables B.1 and B.2) and of nickel and nickel/chromium coatings (see Table B.3) under the conditions of the salt spray test according to ISO 9227.

Table B.1 — Neutral salt spray corrosion protection performance of zinc and cadmium

Designation code for coatings ^a (system B ^b)	Nominal coating thickness μm	Chromate treatment designation ^c	First appearance of white corrosion product h	First appearance of red rust	
				Cadmium h	Zinc h
Fe/Zn or Fe/Cd 3c1A	3 ^d	A	2	24	12
Fe/Zn or Fe/Cd 3c1B		B	6	24	12
Fe/Zn or Fe/Cd 3c2C		C	24	36	24
Fe/Zn or Fe/Cd 3c2D		D	24	36	24
Fe/Zn or Fe/Cd 5c1A	5	A	6	48	24
Fe/Zn or Fe/Cd 5c1B		B	12	72	36
Fe/Zn or Fe/Cd 5c2C		C	48	120	72
Fe/Zn or Fe/Cd 5c2D		D	72	168	96
Fe/Zn or Fe/Cd 5Bk		Bk	12	—	—
Fe/Zn or Fe/Cd 8c1A	8	A	6	96	48
Fe/Zn or Fe/Cd 8c1B		B	24	120	72
Fe/Zn or Fe/Cd 8c2C		C	72	168	120
Fe/Zn or Fe/Cd 8c2D		D	96	192	144
Fe/Zn or Fe/Cd 8Bk		Bk	24	120	72
Fe/Zn or Fe/Cd 12c1A	12	A	6	144	72
Fe/Zn or Fe/Cd 12c1B		B	24	192	96
Fe/Zn or Fe/Cd 12c2C		C	72	240	144
Fe/Zn or Fe/Cd 12c2D		D	96	264	168
Fe/Zn or Fe/Cd 12Bk		Bk	24	192	96
Fe/Zn or Fe/Cd 25c1A	25	A	data not available		
Fe/Zn or Fe/Cd 25c1B		B			
Fe/Zn or Fe/Cd 25c2C		C			
Fe/Zn or Fe/Cd 25c2D		D			
Fe/Zn or Fe/Cd 25Bk		Bk			

^a For zinc coatings see classification code in ISO 2081. For cadmium coatings see classification code in ISO 2082.

^b For designation code systems, see clause 13.

^c Chromate treatments are designated in table B.2.

^d Low coating thicknesses impair chromate conversion performance.

Table B.2 — Designation of chromate treatments

Class	Designation	Type	Typical appearance	Corrosion protection
1	A	Clear	Transparent, clear, sometimes with a bluish tinge	Slight, for example against staining during handling or against high humidity in mildly corrosive conditions
	B	Bleached	Transparent with slight iridescence	
2	C	Iridescent	Yellow iridescent	Considerable, including protection against certain organic vapours
	D	Opaque	Olive green shading to brown or bronze	
	Bk ^a	Black	Black with slight iridescence	Different degrees of corrosion protection
NOTE This table is modified from ISO 4520:1981 by the addition of black treatment.				
^a Black coatings in addition to types A to D possible.				

Table B.3 — Salt spray corrosion protection performance of nickel and nickel/chromium coatings

Designation code for coatings ^a (system B ^b)				First appearance of red rust on significant surfaces	
Copper or copper alloy base		Ferrous material base		Neutral salt spray test (NSS) ^e	Copper-accelerated acetic acid salt spray test (CASS)
Nickel ^c	Nickel + chromium ^{c, d}	Nickel ^c	Nickel + chromium or copper + nickel + chromium ^{c, d}		
Cu/Ni 3b	Cu/Ni 3b Cr r	Fe/Ni 5b	Fe/Ni 5b Cr	—	— ^f
Cu/Ni 5b	Cu/Ni 5b Cr r	Fe/Ni 10b	Fe/Ni 10b Cr Fe/Cu 10 Ni 5b Cr r	12 h	— ^f
Cu/Ni 10b	Cu/Ni 10b Cr r	Fe/Ni 20b	Fe/Ni 20b Cr Fe/Cu 20 Ni 10 b Cr r	48 h	— ^f
Cu/Ni 20b	Cu/Ni 20b Cr r	Fe/Ni 30b	Fe/Ni 30b Cr	—	8 h
Not recommended	Cu/Ni 30d Cr r	Not recommended	Fe/Ni 40d Cr	—	16 h
^a For nickel coatings see classification code in ISO 1456:1988. ^b For designation code systems see clause 13. ^c "b" refers to bright nickel deposits and "d" refers to duplex nickel deposits. ^d "r" refers to regular (conventional) chromium, minimum thickness 0,3 µm. ^e Neutral salt spray tests (NSS) are not usually specified for Ni/Cr coatings. ^f Performance times in copper-accelerated acetic acid salt spray test (CASS) for the lower grades of coating would be too short to be meaningful.					

Annex C (informative)

Guidance on procedures that may be adopted to accommodate thick coatings

C.1 Modification of thread dimensions

When, in order to provide improved corrosion resistance, it is required to deposit coatings thicker than those that appear in Table 2, or alternatively, when it is required to apply coatings to parts of pitches smaller than appear in Table 2, it is necessary to manufacture threads to special limits and tolerances.

The minimum pitch limits of applicability in Table 2 can be lowered if for any particular thread the normal tolerance is confined to the range near the minimum material limits (external threads) or maximum material limits (internal threads). This provides a greater fundamental deviation or, in the case of tolerance position H, it provides a deviation which does not otherwise exist. Alternatively, the whole tolerance zone can be displaced to provide a greater fundamental deviation.

The minimum fundamental deviation required for particular pitches and deposit thicknesses is given in Table C.1.

Table C.1 — Minimum fundamental deviation required to accommodate coatings too thick to be applied to standards threads — Metric threads

Coating thickness μm	Minimum fundamental deviation, μm			
	If local thickness measurement is agreed	If batch average thickness measurement is agreed		
	All nominal lengths	$l \leq 5d$	$5d < l \leq 10d$	$10d < l \leq 15d$
3	12	12	15	18
5	20	20	25	30
8	32	32	40	48
10	40	40	50	60
12	48	48	60	72
15	60	60	75	90
20	80	80	100	120
25	100	100	125	150
30	120	120	150	180

NOTE Since larger fundamental deviations for the thicker deposits may significantly reduce the thread engagement, their application should be agreed between manufacturer and purchaser.

C.2 Selective electroplating

Where a thick deposit is required on a portion of the fastener, for example the heads of bolts or blind nuts, it is often possible to use the procedure of selective electroplating. In such cases the thickness of the deposits applied to the different areas of the part should be specified.

Annex D (normative)

Determination of batch average thickness

D.1 Determination for cadmium and zinc

D.1.1 Procedure

Degrease the sample of parts in an organic solvent, dry thoroughly and weigh to an accuracy of 1 in 10 000; then totally immerse the parts in the requisite stripping solution and turn them over to allow free access to all surfaces. After the effervescence has ceased, remove the parts, wash immediately in running water, and wipe with a soft cloth to remove any loose deposits. Immerse in clean acetone, remove, dry thoroughly and reweigh.

D.1.2 Reagents

A stripping solution consists of

- hydrochloric acid ($1,16 \text{ g/ml} \leq \rho \leq 1,18 \text{ g/ml}$): 800 ml
- distilled water: 200 ml
- antimony trioxide: 20 g

D.1.3 Calculations

D.1.3.1 Calculate the batch average thickness of coating, in micrometres, using the following formula:

$$\text{Batch average thickness} = \frac{K(m_0 - m_1)}{A}$$

where

K is a factor dependent on the density of the deposit metal $\left(K = \frac{10\,000}{\rho} \text{ cm}^3/\text{g} \right)$;

m_0 is the original mass, in grams, of the sample;

m_1 is the final mass, in grams, of the sample;

A is the total area, in square centimetres, of the parts of the sample.

D.1.3.2 Values of K are as follows:

- for cadmium, $K = 1\,160$, assuming a mass density of $\rho = 8,6 \text{ g/cm}^3$ for cadmium;
- for zinc, $K = 1\,410$, assuming a mass density of $\rho = 7,1 \text{ g/cm}^3$ for zinc.

ISO 4042:1999(E)**D.2 Determination for nickel and nickel with chromium****D.2.1 Procedure**

Degrease the sample of parts in an organic solvent, dry thoroughly and weigh to an accuracy of 1 in 10 000.

If the batch of fasteners has been chromium-plated, remove the chromium by immersing and stirring them in stripping solution A, which dissolves the chromium in less than 2 min, after which time there should be no appreciable gassing. The parts shall be removed without delay and rinsed in water, prior to stripping the nickel by the method given in either D.2.1.1 or D.2.1.2.

D.2.1.1 Nickel on steel

Stripping solution B (see D.2.2), maintained between 75 °C and 85 °C, will completely strip 7,5 µm of nickel in 30 min, provided the parts are turned over. The copper undercoat which is also stripped will be counted as if it were nickel, provided it does not exceed 0,5 µm in thickness.

D.2.1.2 Nickel on copper or copper alloy

Stripping solution C (see D.2.2), maintained between 80 °C and 90 °C, will completely strip 2,5 µm in about 10 min and complete removal of the nickel will be indicated by the absence of further gassing. Parts are usually suspended in the solution on thin copper wire.

As soon as the nickel coating has completely dissolved, remove the parts, wash well with water, wipe and dip in clean acetone. Dry and reweigh as before.

D.2.2 Reagents

The stripping solutions consist of one of the following:

- a) stripping solution A
 - antimony trioxide: 120 g/l
 - hydrochloric acid ($\rho > 1,16$ g/ml) to make up to a one litre solution
- b) stripping solution B
 - sodium meta-nitrobenzene sulfonate: 65 g
 - sodium hydroxide: 10 g
 - sodium cyanide: 100 g

Make up to a one litre solution with water

- c) stripping solution C
 - orthophosphoric acid ($\rho \approx 1,75$ g/ml)

NOTE It is dangerous for water to come into contact with the hot acid; water lost by evaporation should be replaced only when the solution has cooled.

Proprietary chemical stripping solutions for nickel may be used provided it can be shown that there is only negligible attack on the base metal (i.e. less than 0,5 µm of base metal being removed).

D.2.3 Calculations

Calculate the batch average thickness of coating, in micrometres, using the following formula:

$$\text{Batch average thickness} = \frac{K \times (m_0 - m_1)}{A}$$

where

$$K = \frac{10000}{\rho} = 1120, \text{ assuming the mass density of nickel } \rho = 8,9 \text{ g/cm}^3;$$

m_0 is the original mass, in grams, of the sample;

m_1 is the final mass, in grams, of the sample;

A is the total area, in square centimetres, of the parts of the sample.

The surface area A can be evaluated according to informative annex G.

Annex E (normative)

Designation code, system A, for electroplated coatings on threaded parts

NOTE For designation code systems, see clause 13.

E.1 Code system A

The following code system is given for electroplated coatings.

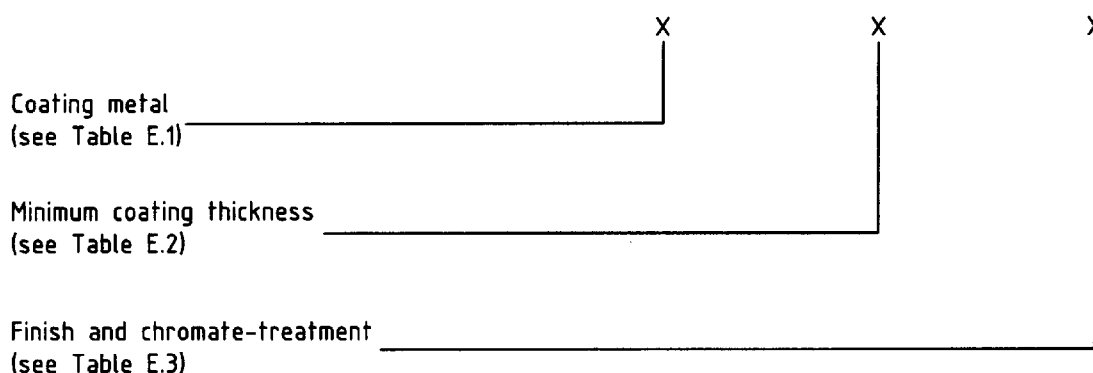

Table E.1 — Coating metal/alloy

Coating metal/alloy		Designation
Symbol	Elements	
Zn	Zinc	A
Cd ^a	Cadmium	B
Cu	Copper	C
CuZn	Brass	D
Ni ^b	Nickel	E
Ni ^b Cr ^r ^b	Nickel–chromium	F
CuNi ^b	Copper–nickel	G
CuNi ^b Cr ^r ^b	Copper–nickel–chromium ^c	H
Sn	Tin	J
CuSn	Copper–tin (bronze)	K
Ag	Silver	L
CuAg	Copper–silver	N
ZnNi	Zinc–nickel	P
ZnCo	Zinc–cobalt	Q
ZnFe	Zinc–iron	R

^a Use of cadmium is restricted or prohibited in certain countries.

^b For ISO classification code see ISO 1456.

^c Thickness of chromium approximately 0,3 μm.

Table E.2 — Coating thickness (total deposit thickness)

Coating thickness μm		Designation
one coating metal	two coating metals ^a	
no coating thickness required	—	0
3	—	1
5	2 + 3	2
8	3 + 5	3
10	4 + 6	9
12	4 + 8	4
15	5 + 10	5
20	8 + 12	6
25	10 + 15	7
30	12 + 18	8

^a The thicknesses specified for the first and the second coating metal apply for all coating combinations except that chromium is the top coating which has always a thickness of 0,3 μm.

Table E.3 — Finish and chromate treatment

Finish	Passivation by chromate treatment ^a : typical colour	Designation
Dull	no colour	A
	bluish to bluish iridescent ^b	B
	yellowish gleaming to yellow-brown, iridescent	C
	drab olive to olive brown	D
Semi-bright	no colour	E
	bluish to bluish iridescent ^b	F
	yellowish gleaming to yellow-brown, iridescent	G
	drab olive to olive-brown	H
Bright	no colour	J
	bluish to bluish iridescent ^b	K
	yellowish gleaming to yellow-brown, iridescent	L
	drab olive to olive-brown	M
High-bright	no colour	N
Optional	like B, C or D	P
Dull	brown-black to black	R
Semi-bright	brown-black to black	S
Bright	brown-black to black	T
All finishes	no chromate treatment ^c	U

^a Passivation treatments are possible only with zinc or cadmium coatings.
^b Applies to zinc coating only.
^c Example for such a coating: A5U

ISO 4042:1999(E)**E.2 Designation****EXAMPLE:**

A hexagon head bolt ISO 4014 - M10 × 60 - 8.8 with electroplated zinc coating (A from Table E.1) having a minimum coating thickness of 5 μm (2 from Table E.2) and brightness condition "bright", being chromated yellow iridescent (L from Table E.3) is designated as follows:

Hexagon head bolt ISO 4014 - M10 × 60 - 8.8 - A2L

NOTE 1 If no minimum coating thickness is explicitly required, then the symbol "0" of the coating thickness according to Table E.2 should be indicated in the code number – for example A0P – so that the code number contains complete specifications. Symbol "0" applies correspondingly to threaded parts below M1,6 or other very small parts.

NOTE 2 If other treatments are required, for example greased or oiled, this should be agreed upon. If applicable, this treatment may be added to the designation as clear text.

Annex F (informative)

Examples for coating designation

EXAMPLE 1 Electroplated zinc coating, coating thickness 8 μm , bright, with yellow iridescent chromate conversion coating

Designation to system A: A3L	Designation to system B: Fe/Zn8c2C
<p>where</p> <ul style="list-style-type: none"> — A refers to Zn — 3 is the code number for 8 μm — L refers to bright with yellow iridescent chromate conversion coating 	<p>where</p> <ul style="list-style-type: none"> — Fe refers to the basic metal — Zn refers to the coating metal — 8 is the minimum coating thickness in μm — c refers to chromate conversion coating — 2 is the class of chromate conversion coating — C is the type of chromate conversion coating

EXAMPLE 2 Electroplated nickel coating, thickness 20 μm , bright, plus regular coating of chromium (0,3 μm)

Designation to system A: F6J	Designation to system B: Fe/Ni 20b Cr r
<p>where</p> <ul style="list-style-type: none"> — F refers to nickel-chromium with chromium 0,3 μm — 6 is the code number for 20 μm — J refers to bright, no colour 	<p>where</p> <ul style="list-style-type: none"> — Fe refers to the basic metal — Ni refers to the coating metal — 20 is the minimum coating thickness of nickel in μm — b refers to bright — Cr refers to the chromium coating — r refers to regular (i.e. 0,3 μm)

Annex G (informative)

Surface areas of bolts, screws and nuts

This annex gives guidance for the evaluation of the surface areas of bolts, screws and nuts which are needed for the determination of the batch average thickness according to informative annex D.

NOTE The surface areas given in Tables G.1 and G.2 apply only if agreed between the parties concerned.

G.1 Bolts and screws

To obtain the total surface area of a bolt or screw the following parameter values are necessary (see Figure G.1):

- the surface area A_1 of a length of 1 mm of the threaded shank of the bolt or screw;
- the surface area A_2 of a length of 1 mm of the unthreaded shank of the bolt or screw;
- the surface area A_3 of the head (including surface of the end face).

The total surface area A is then calculated as follows:

$$A = A_1 \times \text{thread length} + A_2 \times \text{shank length} + A_3$$

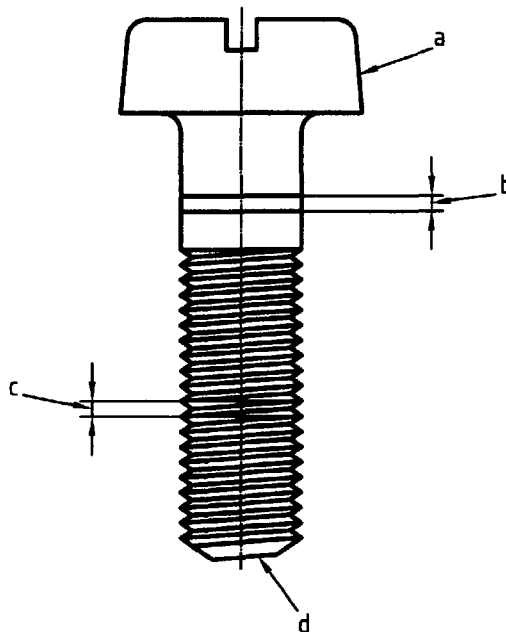

a Total surface area of the head including surface area of the end face, see ^d

b Surface area of the shank of 1 mm length

c Surface area of the threaded part of 1 mm length

d Surface area of the end face is included in the surface area of the head (A_3)

Figure G.1 — Surface area

If the thread is cut, the unthreaded shank will be approximately equal to the basic major diameter (nominal diameter). If the thread is rolled, the unthreaded shank will be approximately equal to either the pitch diameter (reduced shank) or the basic major diameter (full shank).

Table G.1 gives values for the surface areas A_1 , A_2 and A_3 for different shank and head types.

Table G.1 — Surface areas of bolts and screws

Dimensions in square millimetres

Thread size (coarse thread)	Area per millimetre length			Area of head, A_3				
	Threaded shank, A_1 (coarse thread)	Unthreaded shank, A_2		Flat countersunk head	Raised countersunk head	Pan head	Cheese head	Hexagon head
		Full shank	Reduced shank (coarse thread)					
M1,6	7,34	5,03	4,32	20,4	22,1	—	19,3	29,7
M2	9,31	6,27	5,44	32,6	35,5	—	32,0	47,1
M2,2	10,21	6,91	5,99	37,8	40,9	—	37,3	—
M2,5	11,81	7,85	6,91	49,9	54,1	56,4	47,0	72,2
M3	14,32	9,42	8,36	66,7	72,2	78,3	72,8	91,0
M3,5	16,65	11,00	9,75	85,8	93,0	110,4	91,4	—
M4	18,97	12,57	11,10	118,8	128,6	144,9	120,3	152,9
M4,5	21,49	14,15	12,55	128,1	138,6	182,2	162,1	—
M5	23,98	15,70	14,02	167,7	181,6	225,2	184,1	297,7
M6	28,62	18,85	16,71	241,8	261,2	319,6	258,3	312,2
M8	33,48	25,15	22,43	429,8	464,6	577,9	439,4	541,3
M10	48,31	31,42	28,17	671,5	725,8	901,8	666,0	905,8
M12	58,14	37,63	33,98	990,5	1 064	—	864	1 151
M14	67,97	43,99	39,45	1 257	1 357	—	1 158	1 523
M16	78,69	50,27	45,67	1 720	1 859	—	1 509	1 830
M18	87,63	56,54	50,88	2 075	2 240	—	1 913	2 385

NOTE For the time being values for bolts and screws with sizes > M18 or with fine pitch thread are not available and should be calculated as appropriate.

G.2 Nuts

Table G.2 gives the surface areas of hexagon nuts style 1.

The effective surface area of a nut for the purpose of electroplated coating application is normally less than its actual geometrical area because of the difficulty in attaining uniform distribution of the coating over the internal threads, the majority of the coating being on the first thread at each end.

For the purpose of this annex, therefore, the calculation of the surface area of a nut has been based on a solid piece in the shape of the nut but neither drilled nor tapped.

ISO 4042:1999(E)

Table G.2 — Surface areas of hexagon nuts style 1

Surfaces in square millimetres

Thread size	Surface area <i>A</i>
M1,6	32,2
M2	49,7
M2,2	—
M2,5	77,4
M3	95,9
M3,5	—
M4	163,2
M4,5	—
M5	221,3
M6	345,8
M8	585,8
M10	971,0
M12	1 282
M14	1 676
M16	2 078
M18	2 678

NOTE For the time being values for nuts with sizes > M18 and nuts of style 2 are not available and should be calculated as appropriate.

Bibliography

- [1] ISO 8991:1986, *Designation system for fasteners*.
- [2] ISO 9588:—³⁾, *Metallic or other inorganic coatings — Post-coating treatments of iron and steel for reducing the risk of hydrogen embrittlement*.
- [3] TROIANO, A. R., *The role of hydrogen and other interstitials in the mechanical behavior of metals*, Transactions of the American Society of Metals, Vol. 52, 1960, p. 54.

³⁾ To be published.

Annex ZA (normative)
Normative references to international publications
with their relevant European publications

This European Standard incorporates by dated or undated reference, provisions from other publications. These normative references are cited at the appropriate places in the text and the publications are listed hereafter. For dated references, subsequent amendments to or revisions of any of these publications apply to this European Standard only when incorporated in it by amendment or revision. For undated references the latest edition of the publication referred to applies.

<u>Publication</u>	<u>Year</u>	<u>Title</u>	<u>EN</u>	<u>Year</u>
ISO 2064	1980	Metallic and other non-organic coatings - Definitions and conventions concerning the measurement of thickness	EN ISO 2064	1994

BSI — British Standards Institution

BSI is the independent national body responsible for preparing British Standards. It presents the UK view on standards in Europe and at the international level. It is incorporated by Royal Charter.

Revisions

British Standards are updated by amendment or revision. Users of British Standards should make sure that they possess the latest amendments or editions.

It is the constant aim of BSI to improve the quality of our products and services. We would be grateful if anyone finding an inaccuracy or ambiguity while using this British Standard would inform the Secretary of the technical committee responsible, the identity of which can be found on the inside front cover. Tel: 020 8996 9000. Fax: 020 8996 7400.

BSI offers members an individual updating service called PLUS which ensures that subscribers automatically receive the latest editions of standards.

Buying standards

Orders for all BSI, international and foreign standards publications should be addressed to Customer Services. Tel: 020 8996 9001. Fax: 020 8996 7001.

In response to orders for international standards, it is BSI policy to supply the BSI implementation of those that have been published as British Standards, unless otherwise requested.

Information on standards

BSI provides a wide range of information on national, European and international standards through its Library and its Technical Help to Exporters Service. Various BSI electronic information services are also available which give details on all its products and services. Contact the Information Centre. Tel: 020 8996 7111. Fax: 020 8996 7048.

Subscribing members of BSI are kept up to date with standards developments and receive substantial discounts on the purchase price of standards. For details of these and other benefits contact Membership Administration. Tel: 020 8996 7002. Fax: 020 8996 7001.

Copyright

Copyright subsists in all BSI publications. BSI also holds the copyright, in the UK, of the publications of the international standardization bodies. Except as permitted under the Copyright, Designs and Patents Act 1988 no extract may be reproduced, stored in a retrieval system or transmitted in any form or by any means – electronic, photocopying, recording or otherwise – without prior written permission from BSI.

This does not preclude the free use, in the course of implementing the standard, of necessary details such as symbols, and size, type or grade designations. If these details are to be used for any other purpose than implementation then the prior written permission of BSI must be obtained.

If permission is granted, the terms may include royalty payments or a licensing agreement. Details and advice can be obtained from the Copyright Manager. Tel: 020 8996 7070.