

# Metallic powders — Determination of apparent density

Part 1: Funnel method (ISO  
3923-1:2008)

ICS 77.160

## National foreword

This British Standard is the UK implementation of EN ISO 3923-1:2010. It is identical to ISO 3923-1:2008. It supersedes BS EN 23923-1:1993 which is withdrawn.

The UK participation in its preparation was entrusted to Technical Committee ISE/65, Sintered metal components.

A list of organizations represented on this committee can be obtained on request to its secretary.

This publication does not purport to include all the necessary provisions of a contract. Users are responsible for its correct application.

**Compliance with a British Standard cannot confer immunity from legal obligations.**

This British Standard was published under the authority of the Standards Policy and Strategy Committee on 31 May 2010

© BSI 2010

ISBN 978 0 580 69470 7

### Amendments/corrigenda issued since publication

Date	Comments

English Version

**Metallic powders - Determination of apparent density - Part 1:  
Funnel method (ISO 3923-1:2008)**

Poudres métalliques - Détermination de la masse  
volumique apparente - Partie 1: Méthode de l'entonnoir  
(ISO 3923-1:2008)

Metallpulver - Ermittlung der Fülldichte - Teil 1:  
Trichterverfahren (ISO 3923-1:2008)

This European Standard was approved by CEN on 16 April 2010.

CEN members are bound to comply with the CEN/CENELEC Internal Regulations which stipulate the conditions for giving this European Standard the status of a national standard without any alteration. Up-to-date lists and bibliographical references concerning such national standards may be obtained on application to the CEN Management Centre or to any CEN member.

This European Standard exists in three official versions (English, French, German). A version in any other language made by translation under the responsibility of a CEN member into its own language and notified to the CEN Management Centre has the same status as the official versions.

CEN members are the national standards bodies of Austria, Belgium, Bulgaria, Croatia, Cyprus, Czech Republic, Denmark, Estonia, Finland, France, Germany, Greece, Hungary, Iceland, Ireland, Italy, Latvia, Lithuania, Luxembourg, Malta, Netherlands, Norway, Poland, Portugal, Romania, Slovakia, Slovenia, Spain, Sweden, Switzerland and United Kingdom.



EUROPEAN COMMITTEE FOR STANDARDIZATION  
COMITÉ EUROPÉEN DE NORMALISATION  
EUROPÄISCHES KOMITEE FÜR NORMUNG

**Management Centre: Avenue Marnix 17, B-1000 Brussels**

## Foreword

The text of ISO 3923-1:2008 has been prepared by Technical Committee ISO/TC 119 "Powder metallurgy" of the International Organization for Standardization (ISO) and has been taken over as EN ISO 3923-1:2010.

This European Standard shall be given the status of a national standard, either by publication of an identical text or by endorsement, at the latest by October 2010, and conflicting national standards shall be withdrawn at the latest by October 2010.

Attention is drawn to the possibility that some of the elements of this document may be the subject of patent rights. CEN [and/or CENELEC] shall not be held responsible for identifying any or all such patent rights.

This document supersedes EN 23923-1:1993.

According to the CEN/CENELEC Internal Regulations, the national standards organizations of the following countries are bound to implement this European Standard: Austria, Belgium, Bulgaria, Croatia, Cyprus, Czech Republic, Denmark, Estonia, Finland, France, Germany, Greece, Hungary, Iceland, Ireland, Italy, Latvia, Lithuania, Luxembourg, Malta, Netherlands, Norway, Poland, Portugal, Romania, Slovakia, Slovenia, Spain, Sweden, Switzerland and the United Kingdom.

### Endorsement notice

The text of ISO 3923-1:2008 has been approved by CEN as a EN ISO 3923-1:2010 without any modification.



## Foreword

ISO (the International Organization for Standardization) is a worldwide federation of national standards bodies (ISO member bodies). The work of preparing International Standards is normally carried out through ISO technical committees. Each member body interested in a subject for which a technical committee has been established has the right to be represented on that committee. International organizations, governmental and non-governmental, in liaison with ISO, also take part in the work. ISO collaborates closely with the International Electrotechnical Commission (IEC) on all matters of electrotechnical standardization.

International Standards are drafted in accordance with the rules given in the ISO/IEC Directives, Part 2.

The main task of technical committees is to prepare International Standards. Draft International Standards adopted by the technical committees are circulated to the member bodies for voting. Publication as an International Standard requires approval by at least 75 % of the member bodies casting a vote.

Attention is drawn to the possibility that some of the elements of this document may be the subject of patent rights. ISO shall not be held responsible for identifying any or all such patent rights.

ISO 3923-1 was prepared by Technical Committee ISO/TC 119, *Powder metallurgy*, Subcommittee SC 2, *Sampling and testing methods for powders (including powders for hardmetals)*.

This third edition cancels and replaces the second edition (ISO 3923-1:1979), which has been technically revised.

ISO 3923 consists of the following parts, under the general title *Metallic powders — Determination of apparent density*:

- *Part 1: Funnel method*
- *Part 2: Scott volumeter method*

# Metallic powders — Determination of apparent density —

## Part 1: Funnel method

### 1 Scope

This part of ISO 3923 specifies the funnel method for the determination of the apparent density of metallic powders under standardized conditions.

The method is intended for metallic powders that flow freely through a 2,5 mm diameter orifice. It may, however, be used for powders that flow with difficulty through a 2,5 mm diameter orifice but flow through a 5 mm diameter orifice.

Methods for the determination of the apparent density of powders that will not flow through a 5 mm diameter orifice are specified in ISO 3923-2.

### 2 Normative references

The following referenced documents are indispensable for the application of this document. For dated references, only the edition cited applies. For undated references, the latest edition of the referenced document (including any amendments) applies.

ISO 3923-2, *Metallic powders — Determination of apparent density — Part 2: Scott volumeter method*

### 3 Principle

Measurement of the mass of a certain quantity of powder, which in a loose condition exactly fills a cup of known volume.

The loose condition is obtained by using, when filling the cup, a funnel placed at a determined distance above the cup.

The ratio between the mass and the volume represents the apparent density.

### 4 Symbols and designation

The symbols and designations used in this International Standard are defined in Table 1.

Table 1

Symbol	Designation	Unit
$\rho_a$	Apparent density of metallic powders (General term)	g/cm <sup>3</sup>
$\rho_{ac}$	Apparent density obtained by the funnel method	g/cm <sup>3</sup>
$m$	Mass of the powder	g
$V$	Volume of the cup	cm <sup>3</sup>

## 5 Apparatus

**5.1 Funnels**, one having an orifice of diameter 2,5 mm and the other an orifice of diameter 5 mm; see Figures 1 and 2, respectively.

**5.2 Cylindrical cup**, having a capacity of  $25 \text{ cm}^3 \pm 0,03 \text{ cm}^3$  and an internal diameter of  $28 \text{ mm} \pm 0,5 \text{ mm}$ . A cup with the same capacity and with an internal diameter of  $30 \text{ mm} \pm 1 \text{ mm}$  is also acceptable.  $28 \text{ mm} \pm 0,5 \text{ mm}$  is however the first option when new equipment is manufactured.

The cup and funnels should be made of a non-magnetic, corrosion-resistant, metallic material having sufficient wall thickness and hardness to avoid distortion and excessive wear. The inner surfaces of the cup and funnels should be polished.

**5.3 Balance**, of sufficient capacity, capable of weighing the test sample to an accuracy of  $\pm 0,01 \text{ g}$ .

**5.4 Stand and horizontal vibration-free base**, to support the cup and funnel, the stand holding the orifice of the funnel 25 mm above the top surface of the cup and coaxially with it; see Figure 3.

Dimensions in millimetres

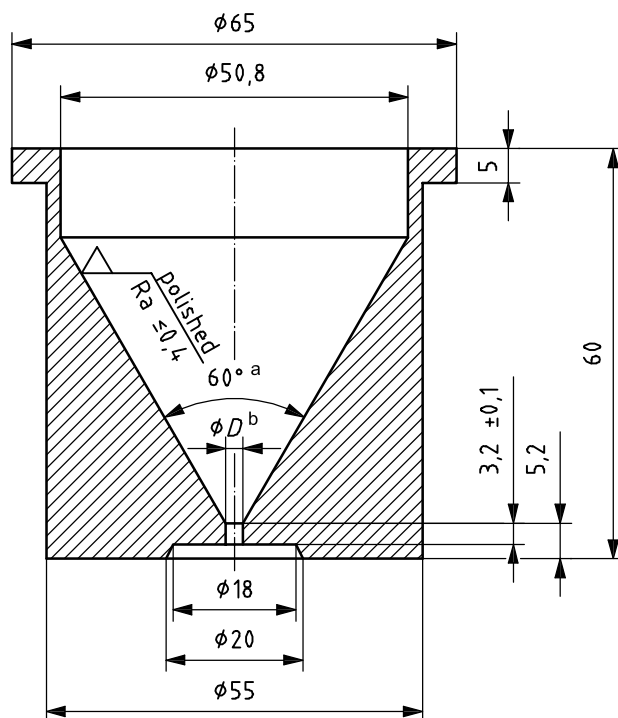

### Key

<sup>a</sup> This value is mandatory.

<sup>b</sup>  $D = 2,5^{+0,2}_0$

Figure 1 — Funnel with orifice diameter 2,5 mm



Dimensions in millimetres

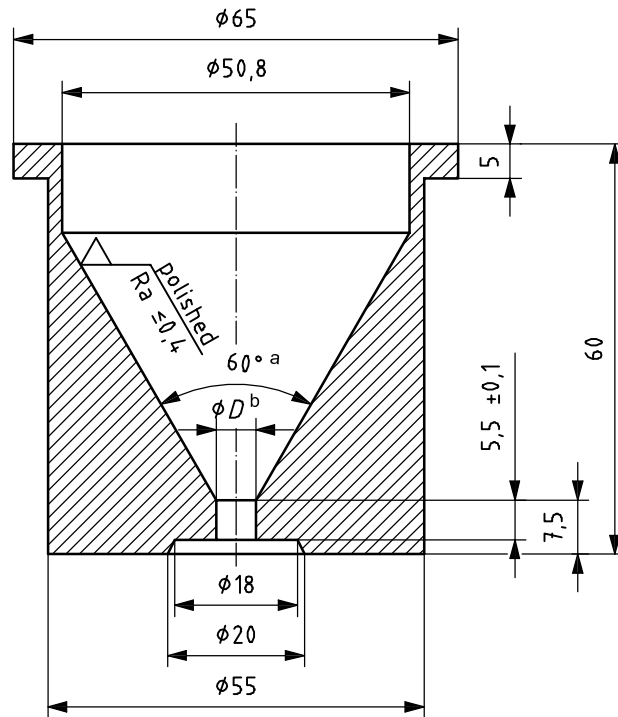

**Key**

a This value is mandatory.

b  $D = 5^{+0,2}_0$

**Figure 2 — Funnel with orifice diameter 5 mm**

Dimensions in millimetres

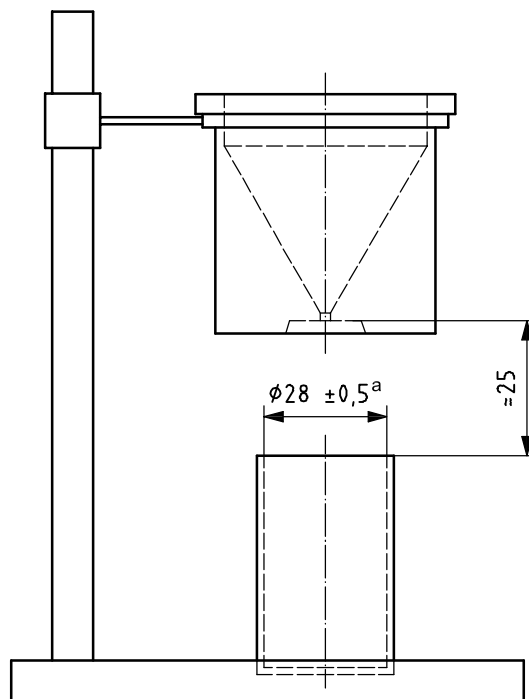

**Key**

<sup>a</sup> A cup with the same capacity and with an internal diameter of  $30 \text{ mm} \pm 1 \text{ mm}$  is also acceptable (see 5.2).

**Figure 3 — Arrangement of the stand with funnel and cup**

## 6 Sample

**6.1** The test sample shall be of at least  $100 \text{ cm}^3$  in volume to allow the determination to be carried out on three test portions.

**6.2** In general, the powder should be tested in the as-received condition. In certain instances, the powder may be dried. However, if the powder is susceptible to oxidation, the drying shall take place in a vacuum or in an inert gas. If the powder contains volatile substances, it shall not be dried.

## 7 Procedure

**7.1** Pour the test portion of powder into the funnel with the 2,5 mm orifice and, from that, directly into the cylindrical cup, until this is completely filled and the powder flows over. Level the powder in one operation with a non-magnetic straight-edge without compressing it, and take care not to jar or vibrate the cup.

**7.2** If the powder does not flow through this funnel, use the funnel with the 5 mm orifice. If the powder still does not flow, it is allowable to initiate flow by poking once with a 1 mm wire from the top of the funnel. The wire shall not enter the cup.

**7.3** After levelling the powder, tap the cup to settle the powder, in order to avoid spilling it during transport. Make sure that there are no adhering particles on the exterior of the cup.

**7.4** Determine the mass of the powder to the nearest 0,01 g.

**7.5** Carry out the determinations on three test portions.

## 8 Expression of results

The apparent density is given by the formula

$$\rho_{ac} = \frac{m}{V} = \frac{m}{25}$$

Report the arithmetical mean of the three determinations to the nearest 0,01 g/cm<sup>3</sup>, and also the highest and lowest results if the scatter between results exceeds 1 % of the mean.

## 9 Precision

### 9.1 Repeatability

Duplicated tests with the same equipment, by the same operator, on a homogenized batch of powder, should be considered suspect if they differ by more than 0,03 g/cm<sup>3</sup> at a 95 % confidence level.

### 9.2 Reproducibility

Results from two different laboratories, on the same homogenized batch of powder, should be considered suspect if they differ by more than 0,05 g/cm<sup>3</sup> at a 95 % confidence level.

## 10 Test report

The test report shall include the following information:

- a) a reference to this part of ISO 3923;
- b) all details necessary for the identification of the test sample;
- c) the drying procedure, if the powder has been dried;
- d) the nominal diameter of the orifice and the use of a wire, if applied;
- e) the result obtained;
- f) all operations not specified in this part of ISO 3923, or regarded as optional;
- g) details of any occurrence which may have affected the result.

---

## BSI - British Standards Institution

BSI is the independent national body responsible for preparing British Standards. It presents the UK view on standards in Europe and at the international level. It is incorporated by Royal Charter.

### Revisions

British Standards are updated by amendment or revision. Users of British Standards should make sure that they possess the latest amendments or editions.

It is the constant aim of BSI to improve the quality of our products and services. We would be grateful if anyone finding an inaccuracy or ambiguity while using this British Standard would inform the Secretary of the technical committee responsible, the identity of which can be found on the inside front cover. Tel: +44 (0)20 8996 9000. Fax: +44 (0)20 8996 7400.

BSI offers members an individual updating service called PLUS which ensures that subscribers automatically receive the latest editions of standards.

### Buying standards

Orders for all BSI, international and foreign standards publications should be addressed to Customer Services. Tel: +44 (0)20 8996 9001. Fax: +44 (0)20 8996 7001 Email: [orders@bsigroup.com](mailto:orders@bsigroup.com) You may also buy directly using a debit/credit card from the BSI Shop on the Website <http://www.bsigroup.com/shop>

In response to orders for international standards, it is BSI policy to supply the BSI implementation of those that have been published as British Standards, unless otherwise requested.

### Information on standards

BSI provides a wide range of information on national, European and international standards through its Library and its Technical Help to Exporters Service. Various BSI electronic information services are also available which give details on all its products and services. Contact Information Centre. Tel: +44 (0)20 8996 7111 Fax: +44 (0)20 8996 7048 Email: [info@bsigroup.com](mailto:info@bsigroup.com)

Subscribing members of BSI are kept up to date with standards developments and receive substantial discounts on the purchase price of standards. For details of these and other benefits contact Membership Administration. Tel: +44 (0)20 8996 7002 Fax: +44 (0)20 8996 7001 Email: [membership@bsigroup.com](mailto:membership@bsigroup.com)

Information regarding online access to British Standards via British Standards Online can be found at <http://www.bsigroup.com/BSOL>

Further information about BSI is available on the BSI website at <http://www.bsigroup.com>.

### Copyright

Copyright subsists in all BSI publications. BSI also holds the copyright, in the UK, of the publications of the international standardization bodies. Except as permitted under the Copyright, Designs and Patents Act 1988 no extract may be reproduced, stored in a retrieval system or transmitted in any form or by any means – electronic, photocopying, recording or otherwise – without prior written permission from BSI.

This does not preclude the free use, in the course of implementing the standard, of necessary details such as symbols, and size, type or grade designations. If these details are to be used for any other purpose than implementation then the prior written permission of BSI must be obtained.

Details and advice can be obtained from the Copyright and Licensing Manager. Tel: +44 (0)20 8996 7070 Email: [copyright@bsigroup.com](mailto:copyright@bsigroup.com)

BSI Group  
Headquarters 389  
Chiswick High Road,  
London, W4 4AL, UK  
Tel +44 (0)20 8996 9001  
Fax +44 (0)20 8996 7001  
[www.bsigroup.com/  
standards](http://www.bsigroup.com/standards)