

**Methods of test for petroleum
and its products —
BS 2000-189/190:
Crude petroleum and liquid
or solid petroleum
products — Determination of
density or relative density —
Capillary-stoppered
pycnometer and graduated
bicapillary pycnometer
methods**

(Identical with IP 189/190-2005)

The European Standard EN ISO 3838:2004 has the status of a
British Standard

ICS 75.040; 75.080

National foreword

This British Standard is the official English language version of EN ISO 3838:2004. It is identical with ISO 3838:2004. It supersedes BS EN ISO 3838:1996 which is withdrawn.

The UK participation in its preparation was entrusted to Technical Committee PTI/13, Petroleum testing and terminology, which has the responsibility to:

- aid enquirers to understand the text;
- present to the responsible international/European committee any enquiries on the interpretation, or proposals for change, and keep the UK interests informed;
- monitor related international and European developments and promulgate them in the UK.

A list of organizations represented on this committee can be obtained on request to its secretary.

Energy Institute, under the brand of Institute of Petroleum publishes and sells all parts of BS 2000, and all BS EN petroleum test methods that would be part of BS 2000, both in its annual publication “Standard methods for analysis and testing of petroleum and related products and British Standard 2000 parts” and individually.

Further information is available from:

**Energy Institute, 61 New Cavendish Street, London W1G 7AR.
Tel: 020 7467 7100. Fax: 020 7255 1472.**

Cross-references

The British Standards which implement international or European publications referred to in this document may be found in the *BSI Catalogue* under the section entitled “International Standards Correspondence Index”, or by using the “Search” facility of the *BSI Electronic Catalogue* or of British Standards Online.

This publication does not purport to include all the necessary provisions of a contract. Users are responsible for its correct application.

Compliance with a British Standard does not of itself confer immunity from legal obligations.

Summary of pages

This document comprises a front cover, an inside front cover, the EN ISO title page, the EN ISO foreword page, the ISO title page, pages ii to iv, pages 1 to 18, an inside back cover and a back cover.

The BSI copyright notice displayed in this document indicates when the document was last issued.

Amendments issued since publication

Amd. No.	Date	Comments

This British Standard was published under the authority of the Standards Policy and Strategy Committee on 28 May 2004

© Energy Institute and BSI
28 May 2004

ISBN 0 580 43826 0

EUROPEAN STANDARD

EN ISO 3838

NORME EUROPÉENNE

EUROPÄISCHE NORM

May 2004

ICS 75.080; 75.040

Supersedes EN ISO 3838:1995

English version

Crude petroleum and liquid or solid petroleum products -
Determination of density or relative density - Capillary-stoppered
pycnometer and graduated bicapillary pycnometer methods
(ISO 3838:2004)

Pétrole brut et produits pétroliers liquides ou solides -
Détermination de la masse volumique ou de la densité
relative - Méthodes du pycnomètre à bouchon capillaire et
du pycnomètre bicapillaire gradué (ISO 3838:2004)

Rohöl und flüssige oder feste Mineralölerzeugnisse -
Bestimmung der Dichte oder der relativen Dichte -
Verfahren mittels Pycnometer mit Kapillarstopfen und
Bikapillar-Pycnometer mit Skale (ISO 3838:2004)

This European Standard was approved by CEN on 8 April 2004.

CEN members are bound to comply with the CEN/GENELEC Internal Regulations which stipulate the conditions for giving this European Standard the status of a national standard without any alteration. Up-to-date lists and bibliographical references concerning such national standards may be obtained on application to the Central Secretariat or to any CEN member.

This European Standard exists in three official versions (English, French, German). A version in any other language made by translation under the responsibility of a CEN member into its own language and notified to the Central Secretariat has the same status as the official versions.

CEN members are the national standards bodies of Austria, Belgium, Cyprus, Czech Republic, Denmark, Estonia, Finland, France, Germany, Greece, Hungary, Iceland, Ireland, Italy, Latvia, Lithuania, Luxembourg, Malta, Netherlands, Norway, Poland, Portugal, Slovakia, Slovenia, Spain, Sweden, Switzerland and United Kingdom.



EUROPEAN COMMITTEE FOR STANDARDIZATION
COMITÉ EUROPÉEN DE NORMALISATION
EUROPÄISCHES KOMITEE FÜR NORMUNG

Management Centre: rue de Stassart, 36 B-1050 Brussels

Foreword

This document (EN ISO 3838:2004) has been prepared by Technical Committee ISO/TC 28 "Petroleum products and lubricants" in collaboration with Technical Committee CEN/TC 19 "Petroleum products, lubricants and related products", the secretariat of which is held by NEN.

This European Standard shall be given the status of a national standard, either by publication of an identical text or by endorsement, at the latest by November 2004, and conflicting national standards shall be withdrawn at the latest by November 2004.

This document supersedes EN ISO 3838:1995.

According to the CEN/CENELEC Internal Regulations, the national standards organizations of the following countries are bound to implement this European Standard: Austria, Belgium, Cyprus, Czech Republic, Denmark, Estonia, Finland, France, Germany, Greece, Hungary, Iceland, Ireland, Italy, Latvia, Lithuania, Luxembourg, Malta, Netherlands, Norway, Poland, Portugal, Slovakia, Slovenia, Spain, Sweden, Switzerland and United Kingdom.

Endorsement notice

The text of ISO 3838:2004 has been approved by CEN as EN ISO 3838:2004 without any modifications.

INTERNATIONAL
STANDARD

ISO
3838

Second edition
2004-05-01

**Crude petroleum and liquid or solid
petroleum products — Determination of
density or relative density — Capillary-
stoppered pycnometer and graduated
bicapillary pycnometer methods**

*Pétrole brut et produits pétroliers liquides ou solides — Détermination
de la masse volumique ou de la densité — Méthodes du pycnomètre à
bouchon capillaire et du pycnomètre bicapillaire gradué*



Reference number
ISO 3838:2004(E)

Contents

Page

Foreword.....	iv
1 Scope.....	1
2 Normative references	1
3 Terms and definitions.....	2
4 Principle	2
4.1 Capillary-stoppered pyknometer.....	2
4.2 Graduated bicapillary pyknometer.....	2
5 Apparatus.....	2
6 Preparation of pyknometer	6
7 Calibration of pyknometer.....	6
7.1 Conditioning	6
7.2 Capillary-stoppered pyknometer.....	8
7.3 Graduated bicapillary pyknometer.....	8
7.4 Other reference temperatures	8
7.5 Recalibration	8
8 Procedure for capillary-stoppered pyknometers.....	9
8.1 Procedure for liquids	9
8.2 Procedure for solid or semi-solid samples	9
9 Procedure for graduated bicapillary pyknometers.....	10
10 Calculations	10
10.1 Symbols	10
10.2 Reference, calibration and test temperatures.....	11
10.3 Correction for the thermal expansion of the pyknometer	12
10.4 Calculation of density of a liquid.....	14
10.5 Calculation of relative density of a liquid	15
10.6 Calculation of density or relative density of a solid or semi-solid	16
11 Precision	16
11.1 Capillary-stoppered pyknometer method.....	16
11.2 Graduated bicapillary pyknometer method.....	17
12 Test report.....	17

Foreword

ISO (the International Organization for Standardization) is a worldwide federation of national standards bodies (ISO member bodies). The work of preparing International Standards is normally carried out through ISO technical committees. Each member body interested in a subject for which a technical committee has been established has the right to be represented on that committee. International organizations, governmental and non-governmental, in liaison with ISO, also take part in the work. ISO collaborates closely with the International Electrotechnical Commission (IEC) on all matters of electrotechnical standardization.

International Standards are drafted in accordance with the rules given in the ISO/IEC Directives, Part 2.

The main task of technical committees is to prepare International Standards. Draft International Standards adopted by the technical committees are circulated to the member bodies for voting. Publication as an International Standard requires approval by at least 75 % of the member bodies casting a vote.

Attention is drawn to the possibility that some of the elements of this document may be the subject of patent rights. ISO shall not be held responsible for identifying any or all such patent rights.

ISO 3838 was prepared by Technical Committee ISO/TC 28, *Petroleum products and lubricants*, Subcommittee SC 3, *Static petroleum measurement*.

This second edition cancels and replaces the first edition (ISO 3838:1983), which has been technically revised.

Crude petroleum and liquid or solid petroleum products — Determination of density or relative density — Capillary-stoppered pycnometer and graduated bicapillary pycnometer methods

1 Scope

1.1 This International Standard specifies methods for the determination of the density or relative density of crude petroleum and of petroleum products handled as liquids.

1.2 The capillary-stoppered pycnometer method is also for use with solids and this method may also be used for coal tar products, including road tars, creosote and tar pitches, or for mixtures of these with petroleum products. This method is not suitable for the determination of the density or relative density of highly volatile liquids having Reid vapour pressures greater than 50 kPa according to ISO 3007 or having an initial boiling point below 40 °C.

1.3 The graduated bicapillary pycnometer method is recommended for the accurate determination of the density or relative density of all except the more viscous products, and is particularly useful when only small amounts of samples are available. The method is restricted to liquids having Reid vapour pressures of 130 kPa or less according to ISO 3007 and having kinematic viscosities less than 50 mm²/s [50 centistokes (cSt)] at the test temperature.

Special precautions are specified for the determination of the density or relative density of highly volatile liquids.

2 Normative references

The following referenced documents are indispensable for the application of this document. For dated references, only the edition cited applies. For undated references, the latest edition of the referenced document (including any amendments) applies.

ISO 91-1:1992, *Petroleum measurement tables — Part 1: Tables based on reference temperatures of 15 °C and 60 °F*

ISO 91-2:1991, *Petroleum measurement tables — Part 2: Tables based on a reference temperature of 20 °C*

ISO 653:1980, *Long solid-stem thermometers for precision use*

ISO 3007:1999, *Petroleum products and crude petroleum — Determination of vapour pressure — Reid method*

ISO 3507:1999, *Laboratory glassware — Pycnometers*

ISO 5024:1999, *Petroleum liquids and liquefied petroleum gases — Measurement — Standard reference conditions*

3 Terms and definitions

For the purposes of this document, the following terms and definitions apply.

3.1

density

mass of the substance divided by its volume

NOTE When reporting the density, it is necessary for the unit of density used, together with the temperature, to be explicitly stated, for example kilograms per cubic metre, or grams per millilitre, at t °C.

3.2

apparent mass in air

value obtained by weighing in air against standard masses without making correction for the effect of air buoyancy on either the standard masses or the object weighed

3.3

observed density

value required in order to enter Tables 53A, 53B and 53D, or 59A, 59B and 59D, referred to in ISO 91, determined with soda-lime glass apparatus at a test temperature which differs from the calibration temperature of the apparatus, no correction having been made for the thermal expansion or contraction of the glass

3.4

relative density

ratio of the mass of a volume of a substance at a temperature t_1 to the mass of an equal volume of another substance at a temperature t_2 . The temperatures t_1 and t_2 may be equal. For the purpose of this International Standard, the other substance is water, i.e. the relative density is the ratio of the density of the substance at a temperature t_1 to the density of water at a temperature t_2 .

NOTE When reporting the relative density, it is necessary for the temperatures t_1 and t_2 be explicitly stated. ISO 91-1 refers to tables for the reduction of relative density to 60/60 °F. If results are required referred to another reference temperature, the determination should be carried out at that temperature.

4 Principle

4.1 Capillary-stoppered pycnometer

The masses of equal volumes of the sample and of water are compared. Equal volumes are ensured by the pycnometer being filled so as to overflow when placed in a bath at the test temperature until equilibrium is reached. The calculation (Clause 10) includes corrections for thermal expansion of glass and for buoyancy.

4.2 Graduated bicapillary pycnometer

The graduated arms of the pycnometer are calibrated, using water, in terms of the apparent mass in air of water contained in the pycnometer, and a graph is prepared. The liquid sample is drawn into the dried pycnometer and, after it has reached equilibrium at the test temperature, the liquid levels are noted and the pycnometer weighed. The apparent mass in air of an equal volume of water is read from the graph and the density or relative density of the sample is calculated, with corrections being made as in 4.1.

5 Apparatus

5.1 **Capillary-stoppered pycnometer**, one of the three types shown in Figure 1 (see 8.1.1).

5.1.1 The pycnometers shall conform to the relevant requirements of ISO 3507.

The “warden” form [see a) in Figure 1] is recommended for all except viscous or solid products and should always be used for volatile products. The ground glass cap, or “warden”, greatly reduces expansion and evaporation losses and this form of pycnometer may be used when the test temperature is lower than that of the laboratory.

5.1.2 The form of pycnometer shown in b) in Figure 1, known as the Gay-Lussac type, is suitable for non-volatile liquids except those of high viscosity.

5.1.3 The wide-mouth (Hubbard) form of pycnometer [see c) in Figure 1] is used for very viscous liquids and solids.

5.1.4 As the forms of pycnometer shown in b) and c) in Figure 1 have no “warden” or expansion chamber, they cannot be used when the temperature of the test is so far below that of the laboratory as to cause loss of sample by expansion through the capillary during weighing.

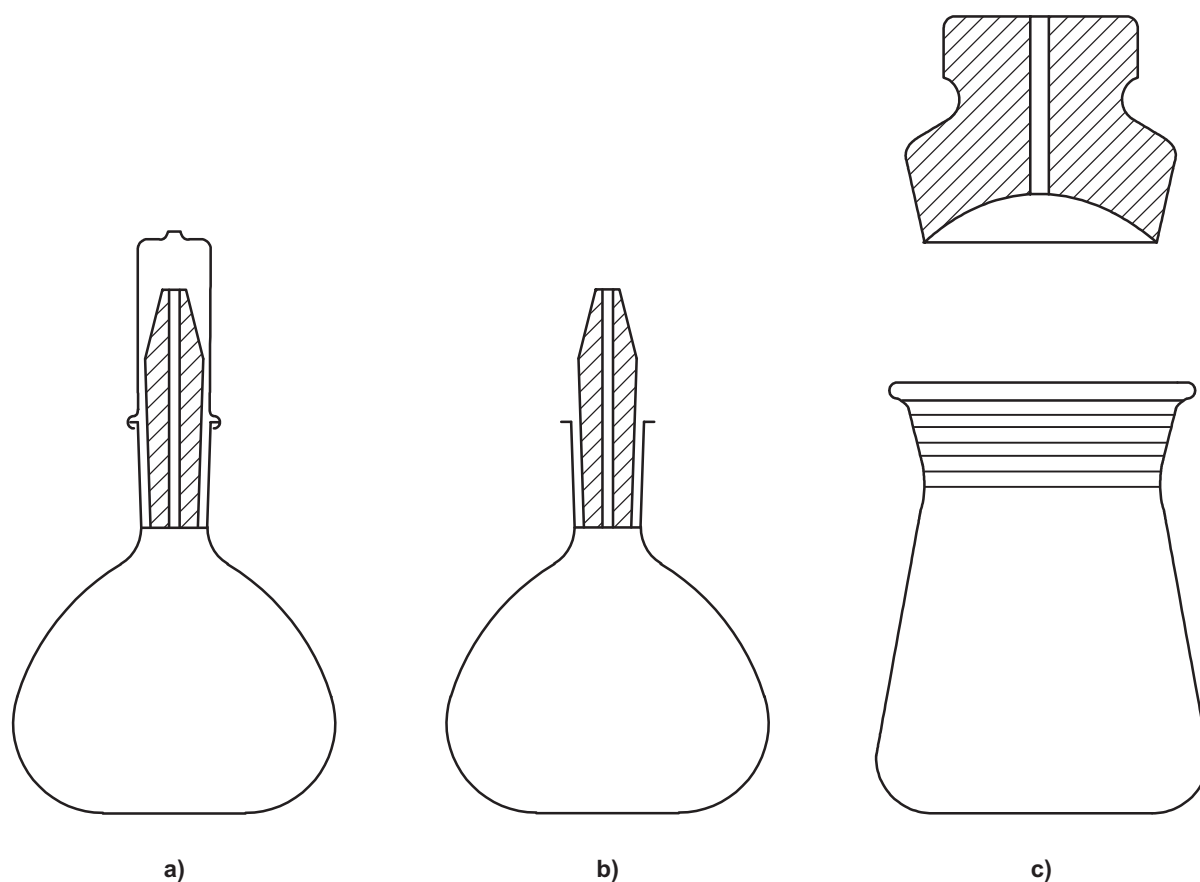

Figure 1 — Capillary-stoppered pycnometers

5.2 Graduated bicapillary pycnometer, capacity 1 ml to 10 ml, conforming to the dimensions given in Figure 2 and the characteristics given in Table 1, constructed of borosilicate glass or soda-lime glass, annealed after manufacture, and having a total mass not exceeding 30 g. Any pycnometer conforming with the requirements of the Lipkin pycnometer given in ISO 3507 may be used.

Table 1 — Characteristics of the graduated bicapillary pycnometer

Nominal capacity, ml	1	2	5	10
Difference between actual capacity and nominal capacity, max, ml	$\pm 0,2$	$\pm 0,3$	$\pm 0,5$	± 1
Maximum mass, g	30			
Overall height, <i>A</i> , mm	175 ± 5			
Height above scale, <i>B</i> , min., mm	40			
Height from bulb to scale, <i>C</i> , min., mm	5			
Distance between centres of vertical limbs, <i>D</i> , mm	28 ± 2			
External diameter of tubing, <i>F</i> , mm	6			
Internal diameter of tubing, <i>G</i> , mm	$1 \pm 0,1$			
Length from bottom of bulb to zero graduation line, <i>H</i> , mm	40			
External diameter of bulb, <i>J</i> , mm	11	14	20	25

Dimensions in millimetres

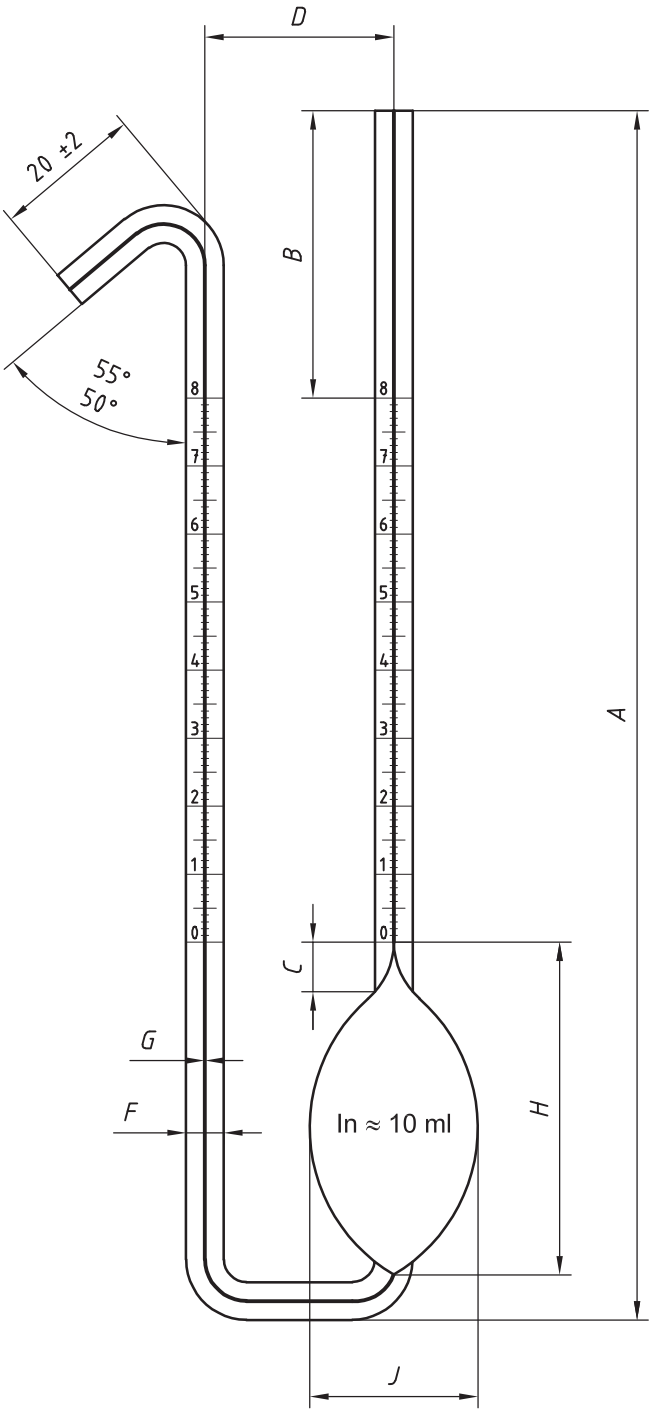

The explanations of symbols *A* to *J* are given in Table 1.

Figure 2 — Graduated bicapillary pyknometer (Lipkin type)

5.3 Constant-temperature water bath, having a depth greater than that of the pycnometer, capable of being maintained within 0,05 °C (0,1 °F) of the desired temperature.

5.4 Bath thermometer, conforming to the specification ISO 653/STL/0,1/-5/+25. Other total immersion thermometers of suitable range and equal or greater accuracy may also be used.

NOTE For the determinations of relative density 60/60 °F, a Fahrenheit thermometer of suitable range graduated at 0,2 °F intervals may be used or the specified Celsius thermometer may be used at 15,56 °C.

5.5 Pycnometer holder (optional), to hold the pycnometer vertically and at the correct depth in the constant temperature bath. It shall be constructed of any suitable metal that will not corrode in the water bath.

A suitable design of holder for the graduated bicapillary pycnometers is shown in Figure 3.

Several pycnometer holders may be conveniently supported in the water bath by the use of a non-corrodible rectangular metal bar of sufficient length to lie across the rim of the bath. A series of holes of sufficient diameter to accommodate the 6,5 mm rod of the pycnometer holder is drilled in the bar at about 45 mm apart. Each rod is secured in its hole by locking the bar between the hexagon nut, and the winged nut and washer.

5.6 Balance, capable of weighing to the nearest 0,1 mg.

6 Preparation of pycnometer

Thoroughly clean the pycnometer and stopper with surfactant cleaning fluid, rinse well with distilled water, then with a water-soluble volatile solvent such as acetone, and dry. Ensure that all traces of moisture are removed, using a current of filtered air if necessary. Cleaning should be carried out in this manner whenever the pycnometer is to be calibrated or whenever liquid fails to drain cleanly from the internal walls of the pycnometer or the capillary of the stopper. Normally, the pycnometer may be cleaned between determinations by washing with a suitable light petroleum spirit such as 40/60 °C petroleum spirit, followed by vacuum drying.

NOTE If surfactant cleaning fluids do not give adequate cleaning, chromosulfuric acid cleaning solution may be used.

CAUTION — Chromosulfuric acid is a health hazard. It is toxic, a recognized carcinogen as it contains Cr (VI) compounds, highly corrosive and potentially hazardous in contact with organic materials. When using chromosulfuric acid cleaning solution, eye protection and protective clothing are essential. Never pipette the cleaning solution by mouth. After use, do not pour cleaning solution down the drain, but neutralize it with great care owing to the concentrated sulfuric acid present, and dispose of it in accordance with standard procedure for toxic laboratory waste (chromium is highly dangerous to the environment).

7 Calibration of pycnometer

7.1 Conditioning

After drying, allow the pycnometer to reach room temperature. Dissipate any static charge which may have formed on it and then weigh to the nearest 0,1 mg.

If the balance case is not fitted with an electrostatic eliminator, electrostatic charges may be dissipated by breathing on the pycnometer, but ensure that the pycnometer has regained constant mass before recording the mass.

For the greatest accuracy, all the weighings should be made at temperatures within a 5 °C range so as to limit differences in air density.

Dimensions in millimetres

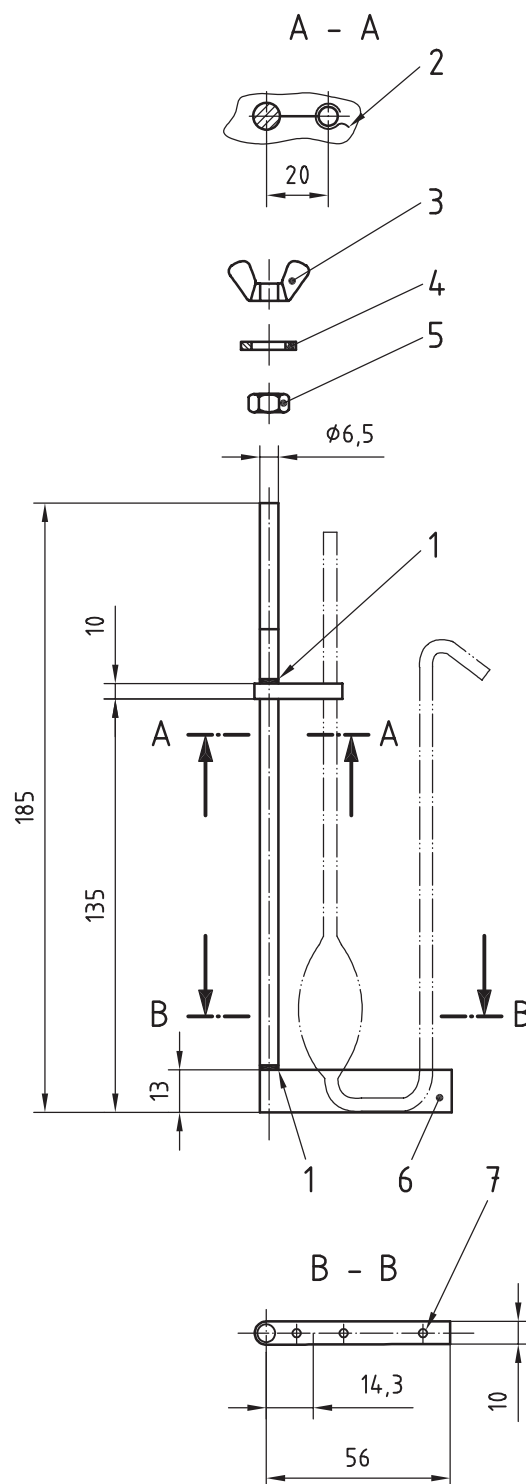
**Key**

- | | | | |
|---|---------------------|---|--|
| 1 | solder | 4 | washer |
| 2 | spring clip 0,32 mm | 5 | hexagon nut |
| | sheet metal (brass) | 6 | sheet metal tray (brass), sheet thickness 0,315 mm |
| 3 | wing nut | 7 | 3 holes, \varnothing 3 mm |

Figure 3 — A suitable design of holder for graduated bicapillary pyknometer

7.2 Capillary-stoppered pycnometer

7.2.1 Fill the pycnometer with freshly boiled distilled water, cooled to slightly below the selected reference temperature, and firmly insert the stopper, taking care to avoid the inclusion of any air bubbles. Immerse the pycnometer to the neck in the constant-temperature bath and maintain it at $(15,00 \pm 0,05) ^\circ\text{C}$, $(20,00 \pm 0,05) ^\circ\text{C}$ or $(60,0 \pm 0,1) ^\circ\text{F}$ as appropriate, for not less than 1 h.

7.2.2 When the pycnometer and its contents have reached the bath temperature, wipe the top of the stopper so that it is dry and the meniscus of the water in the capillary is flush with the top of the stopper. Care is necessary during this operation, since capillary action of the cloth can draw material out of the stopper. Place the "warden" firmly on the stopper (if the pycnometer is of this type).

7.2.3 Remove the pycnometer from the bath. If not of the "warden" form, cool the pycnometer and its contents to a temperature slightly below the temperature of the bath.

7.2.4 Dry the exterior surface of the pycnometer by wiping with a clean, lint-free cloth, dissipate any static charge and weigh to the nearest 0,1 mg.

7.2.5 The difference between the apparent masses in air of the filled and empty pycnometer gives the water equivalent at the selected reference temperature.

7.3 Graduated bicapillary pycnometer

7.3.1 Fill the pycnometer with sufficient freshly boiled, cooled, distilled water to obtain readings near the top of the graduated capillaries. Filling is readily achieved by placing the hooked tip in the liquid while keeping the pycnometer upright, thus allowing the liquid to be drawn over the bend in the capillary by capillary attraction. The pycnometer then fills by siphoning. Place the pycnometer in the constant-temperature bath so that the whole of the liquid in the pycnometer is below the level of the bath liquid. Maintain the temperature of the bath at $(15,00 \pm 0,05) ^\circ\text{C}$, $(20,00 \pm 0,05) ^\circ\text{C}$ or $(60,0 \pm 0,1) ^\circ\text{F}$, as required. Keep the pycnometer in the bath for 20 min then read the scale to the nearest small division at the liquid level in each arm.

7.3.2 Remove the pycnometer from the bath, allow the water on the exterior to drain off. The pycnometer may be dipped into acetone in a beaker to assist drying and wiped with a clean, dry, lint-free cloth. Allow it to come to room temperature, dissipate any static charge, and weigh to the nearest 0,1 mg.

7.3.3 The difference between the apparent masses in air of the filled and empty pycnometer gives the mass of water contained at the test temperature, corresponding to the sum of the two scale readings. By removing successive quantities of water, repeat the determination so as to obtain a series of at least three pairs of readings, together with the corresponding apparent masses in air, with the water level at different scale points on the graduated arms. One pair of readings shall be at the upper end of the scale and another at the lower end. Plot the sums of the scale readings on the two arms against the corresponding masses. The points should lie on a straight line that gives the mass of water contained by the pycnometer for any combination of scale readings. If the points show a scatter of more than two small scale divisions on either side of a straight line drawn through the array of points and subsequent tests do not correct this, discard the pycnometer as imperfect.

7.4 Other reference temperatures

If it is desired to determine the relative density referred to water at some temperature other than $60 ^\circ\text{F}$ or to determine density at a temperature other than $15 ^\circ\text{C}$ or $20 ^\circ\text{C}$, calibrate the pycnometer at the desired temperature.

7.5 Recalibration

Recalibrate pycnometers at intervals as dictated by experience.

It is recommended that new pycnometers should be recalibrated after one year, and thereafter at intervals dependent upon the magnitude of any changes found.

8 Procedure for capillary-stoppered pycnometers

8.1 Procedure for liquids

8.1.1 Choose an appropriate form and size of pycnometer for the sample to be tested. The 25 ml and 50 ml sizes are normally the most suitable.

8.1.2 Weigh the clean, dry calibrated pycnometer, if necessary dispersing any electrostatic charge (see 2nd and 3rd paragraphs of 7.1). Pycnometers of 25 ml or greater capacity should be weighed to the nearest 0,5 mg, and those of smaller capacity to the nearest 0,1 mg.

8.1.3 Fill the pycnometer with the test sample, if necessary warming both sample and pycnometer to assist filling and separation of air bubbles. Bring the pycnometer and its contents to the test temperature t_t (see 10.1) by immersing the pycnometer up to its neck in the constant-temperature bath (see note and 10.2.3). Immerse the pycnometer in the bath for 20 min in order to stabilize the temperature and to permit air bubbles to rise to the surface. If after this time the liquid level is still changing, keep the pycnometer in the bath until the liquid level becomes stable.

NOTE For mixtures of products, it is essential to ensure that the test temperature is the same as the final reporting temperature, unless an approximate value is acceptable and the volumetric composition of the mixture is known together with the correction coefficients of the components in the mixture.

8.1.4 When the temperature is constant, firmly insert the capillary stopper, which has also been brought to the test temperature, taking care to avoid trapping air bubbles below the stopper.

It is essential to ensure that no air bubbles are left trapped in the liquid, and adequate time shall be allowed for air bubbles to rise to the surface before inserting the stopper.

Wipe excess liquid from the top of the stopper so that the meniscus of the liquid in the capillary is flush with the top of the stopper. Place the "warden" over the stopper (if the pycnometer is of this type).

8.1.5 Remove the pycnometer from the bath and, if it is not of the "warden" type, cool to a temperature slightly below t_t . Cool the pycnometer and contents to room temperature if the test temperature is above ambient.

8.1.6 Remove all traces of sample and water from the exterior surface of the pycnometer by wiping with a clean, lint-free cloth, disperse any electrostatic charge and weigh to the precision given in 8.1.2.

8.2 Procedure for solid or semi-solid samples

8.2.1 Weigh the clean, dry calibrated pycnometer, which should be of the wide-mouth type [see c) in Figure 1], to the nearest 0,5 mg. For bituminous materials, only the wide-mouth type shall be used.

8.2.2 Introduce a suitable amount of the sample in the form of small pieces, which should be as regular as possible in order to reduce the possibility of trapping air bubbles. Alternatively, pour the molten sample into the warmed pycnometer, taking care to avoid the inclusion of air bubbles.

8.2.3 Bring the pycnometer and its contents to room temperature and weigh to the nearest 0,5 mg.

8.2.4 Fill the pycnometer with freshly boiled, cooled, distilled water, removing all air bubbles. A fine wire may be used to facilitate the removal of bubbles.

Bring the pycnometer and its contents to the test temperature t_t by immersing the pycnometer up to its neck in the constant-temperature bath. Immerse the pycnometer in the bath for 20 min in order to stabilize the temperature and to permit bubbles to rise to the surface. If after this time the liquid level is still changing, keep the pycnometer in the bath until the liquid level becomes stable.

8.2.5 When the temperature is constant, firmly insert the capillary stopper, which has also been brought to the test temperature, taking care to avoid trapping air bubbles below the stopper. Wipe excess water from the top of the stopper so that the meniscus of the water in the capillary is flush with the top of the stopper.

8.2.6 Remove the pycnometer from the bath and cool to a temperature slightly below t_t . Cool the pycnometer and contents to room temperature if the test temperature is above ambient.

8.2.7 Dry the exterior surface of the pycnometer by wiping with a clean, lint-free cloth, disperse any electrostatic charge and weigh to the nearest 0,5 mg.

9 Procedure for graduated bicapillary pycnometers

9.1 Weigh the clean, dry, calibrated pycnometer to the nearest 0,1 mg, dissipating any electrostatic charge if necessary. (See 2nd and 3rd paragraphs in 7.1.)

9.2 Fill the pycnometer with the sample at approximately the test temperature by the method specified in 7.3.1, so that the liquid levels are in the graduated portions of the capillaries (see note). If the test temperature is lower than the laboratory temperature, low scale readings should be aimed at in order to minimize any losses due to evaporation during weighing. Bring the pycnometer and contents to the test temperature t_t (see 10.1) by immersion for 20 min in the constant-temperature bath as specified in 7.3.1 and obtain readings of the liquid level in the two graduated arms. In the case of more viscous samples, no readings shall be taken until ample time for draining has been allowed after any disturbance of the pycnometer. The 20 min immersion time is normally sufficient, provided that the pycnometer has not been disturbed during this period.

NOTE For mixtures of petroleum products and non-petroleum products, it is essential to ensure that the test temperature is the same as the final reporting temperature, unless an approximate value is acceptable and the volumetric composition of the mixture is known, together with the correction coefficients of the components in the mixture.

9.3 Remove the pycnometer from the bath and allow the water on the exterior to drain off. The pycnometer may be dipped into acetone in a beaker to assist drying and wiped with a clean, dry, lint-free cloth. Allow to reach room temperature, dissipate any electrostatic charge, and weigh to the nearest 0,1 mg.

9.4 When carrying out the determination on highly volatile samples containing appreciable amounts of material boiling below 20 °C, or on any sample where there is uncertainty concerning loss which might result from evaporation during the determination, cool the sample and pycnometer to a temperature of 0 °C to 5 °C before filling. If the dew point is sufficiently high to cause condensation of moisture in the pycnometer during the cooling operation, attach a drying tube to the arm of the pycnometer in order to avoid this. With samples of this type, it is essential to restrict the filling of the pycnometer to obtain a low scale reading, thus minimizing losses due to evaporation. If the total length of unfilled capillary is over 10 cm, the rate of diffusion is so low that, even with highly volatile compounds such as isopentane, vapour losses during the determination are negligibly low.

10 Calculations

10.1 Symbols

The following symbols are used in the calculations:

t_r is any reference temperature, e.g. 15 °C, ISO 5024 (see 10.2.1);

t_c is the temperature at which the pycnometer is calibrated by water filling, (see 10.2.2);

t_t is the temperature at which the pycnometer is filled with the liquid under test, (see 10.2.3);

m_0 is the apparent mass in air, in grams, of the empty pycnometer;

- m_c is the apparent mass in air, in grams, of the pycnometer filled with water at the calibration temperature t_c ;
- m_t is the apparent mass in air, in grams, of the pycnometer filled with the liquid under test at the temperature t_t ;
- m_1 is the apparent mass in air, in grams, of the pycnometer plus solid or semi-solid sample;
- m_2 is the apparent mass in air, in grams, of the pycnometer plus sample, filled with water at the temperature t_t ;
- C is the correction for air buoyancy, in kilograms per cubic metre (see Table 2) (see 7.1, 3rd paragraph);
- ρ_c is the density of water, in kilograms per cubic metre, at the temperature of calibration t_c (see Table 3);
- α_1 is the coefficient of cubical expansion of borosilicate glass (see 10.3.2);
- α_2 is the coefficient of cubical expansion of soda-lime glass (see 10.3.3);
- ρ_t is the density of the sample, in kilograms per cubic metre, at the test temperature t_t ;
- ρ_r is the density of the sample, in kilograms per cubic metre, at any reference temperature t_r ;
- ρ_{15} is the density of the sample, in kilograms per cubic metre, at the reference temperature of 15 °C;
- ρ_{20} is the density of the sample, in kilograms per cubic metre, at the reference temperature of 20 °C;
- ρ_t^1 is the observed density, in kilograms per cubic metre, at the test temperature t_t as determined in soda-lime glass apparatus calibrated at the reference temperature $t_r = 15$ °C or 20 °C, i.e. the observed density uncorrected for glass expansion required for entering the tables referred to in ISO 91.

NOTE These calculations have been based on density, in kilograms per cubic metre but, if it is desired to use density in grams per millilitre, the result should be divided by 1 000 (see Clause 12).

- d_t is the relative density at the test temperature t_t ;
- d_r is the relative density at the reference temperature t_r ;
- d_{60} is the relative density at the reference temperature of 60 °F;
- d_t^1 is the observed relative density at the test temperature t_t as determined in soda-lime glass apparatus calibrated at the reference temperature $t_r = 60$ °F, i.e. the observed relative density uncorrected for glass expansion required for entering the tables referred to in ISO 91.

10.2 Reference, calibration and test temperatures

10.2.1 The standard reference temperature for international trade in petroleum and its products is 15 °C (ISO 5024), but other reference temperatures may be required for legal metrology or other special purposes.

10.2.2 The pycnometer may be calibrated at any convenient temperature and this may correspond with the reference, or test temperatures (see 7.1, 3rd paragraph).

Table 2 — Buoyancy corrections

$\frac{m_1 - m_0}{m_c - m_0}$	Correction <i>C</i> kg/m ³	$\frac{m_1 - m_0}{m_c - m_0}$	Correction <i>C</i> kg/m ³
0,60	0,48	0,80	0,24
0,61	0,47	0,81	0,23
0,62	0,46	0,82	0,22
0,63	0,44	0,83	0,20
0,64	0,43	0,84	0,19
0,65	0,42	0,85	0,18
0,66	0,41	0,86	0,17
0,67	0,40	0,87	0,16
0,68	0,38	0,88	0,14
0,69	0,37	0,89	0,13
0,70	0,36	0,90	0,12
0,71	0,35	0,91	0,11
0,72	0,34	0,92	0,10
0,73	0,32	0,93	0,08
0,74	0,31	0,94	0,07
0,75	0,30	0,95	0,06
0,76	0,29	0,96	0,05
0,77	0,28	0,97	0,04
0,78	0,26	0,98	0,02
0,79	0,25	0,99	0,01

These corrections are calculated for standard air of density 1,222 kg/m³ at 15,56 °C and at a pressure of 101,325 kPa. They are applicable for air density values between 1,1 kg/m³ and 1,3 kg/m³.

See 10.1 for definitions of symbols.

10.2.3 For qualitative purposes, the test temperature is usually chosen to correspond with the required reference temperature. For quantitative purposes involving the calculation of the mass or apparent mass in air of a given quantity of oil, the density or relative density should be determined within 3 °C of the temperature at which the volume of oil is measured by the selected dynamic or static method. However, to minimize the loss of light fractions from very volatile samples, carry out the test at a temperature of 15 °C or below, if the Reid vapour pressure exceeds the following:

- a) for the capillary-stoppered pycnometer: 10 kPa;
- b) for the bicapillary pycnometer: 50 kPa.

10.3 Correction for the thermal expansion of the pycnometer

10.3.1 General

The calculation of density, or of relative density, from measurements made at a temperature t_t that differs from the temperature t_c at which the pycnometer was calibrated, involves a correction for cubical expansion of the glass from which the pycnometer is made.

If the calculation is based on the density or relative density correction tables referred to, or given, in ISO 91, a similar correction may also be required (see 10.3.4).

10.3.2 Pyknometers made of borosilicate glass

10.3.2.1 The coefficients of cubical expansion of borosilicate glasses are known to depend on the source of the glass and to fall into three main categories having coefficients of cubical expansion of 10×10^{-6} , 14×10^{-6} , and $19 \times 10^{-6} \text{ } ^\circ\text{C}^{-1}$ respectively.

NOTE In current production, pyknometers made of borosilicate glass usually have a coefficient of cubical expansion of $10 \times 10^{-6} \text{ } ^\circ\text{C}^{-1}$.

10.3.2.2 For determination of the highest accuracy when borosilicate pyknometers are used, therefore either

- a) ensure that $t_t = t_c$, or
- b) use a pyknometer for which the coefficient of cubical expansion is known.

When the foregoing is not possible and a lower precision is acceptable, the use of $10 \times 10^{-6} \text{ } ^\circ\text{C}^{-1}$ is recommended.

10.3.3 Pyknometers made of soda-lime glass

For pyknometers made of soda-lime glass, the coefficient of cubical expansion may be assumed to be $(25 \pm 2) \times 10^{-6} \text{ } ^\circ\text{C}^{-1}$ (ISO 1768:1975, *Glass hydrometers — Conventional value for the thermal cubic expansion coefficient [for use in the preparation of measurement tables for liquids]*).

10.3.4 Petroleum measurement tables in ISO 91

10.3.4.1 In ISO 91, separate tables are referred to for crude oils, generalized refined products and lubricating oils and are designated "A", "B" and "D" respectively, e.g. Tables 53A, 53B and 53D, or Tables 59A, 59B and 59D. The correct table for the material being tested shall be used

10.3.4.2 The following tables referred to, or given, in ISO 91 are relevant only for determinations on petroleum and petroleum products. The tables shall not be used for non-petroleum products for which it is always necessary to ensure that $t_t = t_r$ when ρ_r or d_r is required.

Table 53	Correction of observed density to density at 15 °C
Table 59	Correction of observed density to density at 20 °C
Table 23	Correction of observed relative density to relative density at 60/60 °F
Table 54	Correction of volume to 15 °C against density at 15 °C
Table 60	Correction of volume to 20 °C against density at 20 °C
Table 24	Correction of volume to 60 °F against relative density at 60/60 °F.

10.3.4.3 Tables 53, 59 and 23 are entered with densities or relative densities determined in glass apparatus calibrated at a temperature t_c in degrees Celsius (Tables 53 and 59) or degrees Fahrenheit (Table 23).

The tables include a correction for the expansion of the glass apparatus used (assumed to be soda-lime glass) for which the conventional value of $(25 \pm 2) \times 10^{-6} \text{ } ^\circ\text{C}^{-1}$ applies (ISO 1768).

10.3.4.4 When entering Table 53, 59 or 23 with the results of determinations made with pycnometers constructed from borosilicate glass, a correction will be required for the difference between the coefficient of cubical expansion of the borosilicate glass and the conventional value for soda-lime glass incorporated in the tables.

10.3.4.5 When the pycnometer used is made of soda-lime glass, no correction is necessary when using Table 53, 59 or 23 when $t_c = 15\text{ °C}$, 20 °C or 60 °F as appropriate to the table entered.

If t_c does not correspond to the reference temperature t_r for which the table used is constructed, an adjustment is required for the expansion of the pycnometer over the temperature range t_c to t_r .

NOTE Alternatively, the corresponding volume correction Table 54, 60 or 24 may be used. These tables do not include any correction for the expansion of glass but have to be entered with a density at the appropriate reference temperature. Consequently, the use of these tables requires a tedious repetitive calculation. This procedure is therefore not recommended and is not covered in 10.4 and 10.5.

10.4 Calculation of density of a liquid

10.4.1 Density at any temperature t_t

10.4.1.1 When $t_t = t_c$

$$\rho_t = \frac{(m_t - m_0) \rho_c}{(m_c - m_0)} + C$$

10.4.1.2 When $t_t \neq t_c$

$$\rho_t = \left[\frac{(m_t - m_0) \rho_c}{(m_c - m_0)} + C \right] \left[\frac{1}{1 - \alpha^1 (t_c - t_t)} \right]$$

where $\alpha^1 = \alpha_1$ or α_2 as appropriate to the pycnometer used.

10.4.2 Density at reference temperature t_r

10.4.2.1 When $t_t = t_c = t_r$

$$\rho_t = \frac{(m_t - m_0) \rho_c}{(m_c - m_0)} + C$$

10.4.2.2 When $t_t = t_c \neq t_r$ ($t_r = 15\text{ °C}$ or 20 °C).

The density determined at the test temperature t_t as in 10.4.1.1 is the true density at t_t . The result obtained shall therefore be adjusted to give the apparent density at t_t in soda-lime glass apparatus calibrated at t_r , before entering Table 53 or 59 referred to in ISO 91. This always applies, irrespective of the glass from which the pycnometer is made, i.e. enter Table 53 or 59 with ρ_t^1 and against t_t extract ρ_{15} or ρ_{20} respectively, interpolating as necessary, where

$$\rho_t^1 = \left[\frac{(m_t - m_0) \rho_c}{(m_c - m_0)} + C \right] \left[1 + (25 \times 10^{-6}) (t_r - t_t) \right]$$

10.4.2.3 When $t_c = t_r \neq t_t$ ($t_r = 15\text{ °C}$ or 20 °C)

a) Pycnometers made of soda-lime glass

Table 53 or 59 shall be entered directly with ρ_t^1 and against t_t the corresponding ρ_{15} or ρ_{20} is extracted, interpolating as necessary, where

$$\rho_t^1 = \frac{(m_t - m_0) \rho_c}{(m_c - m_0)} + C$$

b) Pyknometers made of borosilicate glass

Table 53 or 59 shall be entered with ρ_t^1 adjusted for the differential expansion of the pyknometer glass, and against t_t the corresponding ρ_{15} or ρ_{20} is extracted, interpolating as necessary, where

$$\rho_t^1 = \left[\frac{(m_t - m_0) \rho_c}{(m_c - m_0)} + C \right] [1 + (\alpha_2 - \alpha_1)(t_r - t_t)]$$

Second-order terms, which are not significant, are ignored.

10.4.2.4 When $t_t \neq t_c \neq t_r$

The density determined at the test temperature t_t as in 10.4.1.2 is the true density at t_t . The result obtained shall therefore be adjusted to give the apparent density at t_t in soda-lime glass apparatus calibrated at t_r before entering Table 53 or 59 referred to in ISO 91. This always applies irrespective of the glass from which the pyknometer is made, i.e. enter Tables 53 or 59 with ρ_t^1 and against t_t extract ρ_{15} or ρ_{20} respectively, interpolating as necessary. The expression for ρ_t^1 may be rearranged as follows, ignoring second-order terms which are not significant.

a) Pyknometers made of soda-lime glass

$$\rho_t^1 = \left[\frac{(m_t - m_0) \rho_c}{(m_c - m_0)} + C \right] [1 + \alpha_2 (t_r - t_c)]$$

b) Pyknometers made of borosilicate glass

$$\rho_t^1 = \left[\frac{(m_t - m_0) \rho_c}{(m_c - m_0)} + C \right] [1 + \alpha_1 t_r + \alpha_2 t_t - (\alpha_1 + \alpha_2) t_c]$$

10.4.2.5 When $t_r = t_t \neq t_c$

Use the expression in 10.4.1.2.

10.4.3 Rounding-off of calculations

Carry out all calculations to five significant figures for values below 1 000,00 or 1,000 00 and to six significant figures for values of 1 000,00 or 1,000 00 and above, depending on which units are used for density or whether relative density is being determined.

10.5 Calculation of relative density of a liquid

10.5.1 In accordance with the definition, the appropriate values for d_t , d_t^1 and d_r can be derived by dividing the corresponding values for density in 10.4.1 and 10.4.2, by the density of water in the same units at the required reference temperature (see 10.5.3, note).

10.5.2 When the correction of relative density $t/60$ °F of petroleum and petroleum products is required to the reference temperature of 60 °F (see 10.4.2.2, 10.4.2.3 and 10.4.2.4), use Table 23 referred to in ISO 91-1. t_r , t_t and t_c will be in degrees Fahrenheit and the coefficients of cubical expansion α_1 and α_2 should be stated per degree Fahrenheit. For α_2 the value of 14×10^{-6} °F⁻¹ may be taken.

10.5.3 Carry out all calculations to five decimal places.

NOTE If the value for density is expressed in grams per millilitre, it is essential that the values in Table 3 be divided by 1 000.

10.6 Calculation of density or relative density of a solid or semi-solid

When the procedure described in 8.2 has been used, the following expression

$$\frac{(m_1 - m_0)}{(m_c - m_0 - m_2 + m_1)}$$

shall be substituted for the expression

$$\frac{(m_t - m_0)}{(m_c - m_0)}$$

in the calculation in 10.4.

Tables 23, 53 and 59 apply only to petroleum products and shall not be used for correction of densities or relative densities of tar products.

11 Precision

11.1 Capillary-stoppered pycnometer method

11.1.1 General

The precision of the method, based on estimates of normal good practice, but not derived from statistical analysis of inter-laboratory test results, is as given in 11.1.2 to 11.1.4.

11.1.2 Repeatability

The difference between two test results, obtained by the same operator with the same apparatus under constant operating conditions on identical test material, would in the long run, in the normal and correct operation of the test method, exceed the following value only in one case in twenty:

0,6 kg/m³ or 0,000 6 g/ml or 0,000 6 for relative density.

11.1.3 Reproducibility

The difference between two single and independent test results, obtained by different operators working in different laboratories on identical test material, would in the long run, in the normal and correct operation of the test method, exceed the following value only in one case in twenty:

0,6 kg/m³ or 0,000 6 g/ml or 0,000 6 for relative density

11.1.4 Volatile and very viscous materials

No precision data can be given for volatile or very viscous materials or for solids (see 8.2), other than bituminous binders (see note).

NOTE Precision data for bituminous binders have been determined for bituminous binders sampled in accordance with German national standards for which there are no ISO equivalents. The values for repeatability and reproducibility as defined in 11.1.2 and 11.1.3 respectively are as follows:

Repeatability: 3 kg/m³ or 0,003 g/ml or 0,003 for relative density;

Reproducibility: 5 kg/m³ or 0,005 g/ml or 0,005 for relative density.

11.2 Graduated bicapillary pycnometer method

11.2.1 General

The precision of the method, as obtained by statistical examination of inter-laboratory test results using 5 ml pycnometers is given in 11.2.2 and 11.2.3. The method is not restricted to the ranges 777,0 to 892,0 and 0,777 0 to 0,892 0, but the precision data are not available outside these ranges.

The precision obtainable when using larger pycnometers should be equal to or better than that given in 11.2.2 and 11.2.3.

11.2.2 Repeatability

The difference between two test results, obtained by the same operator with the same apparatus under constant operating conditions on identical test material, would in the long run, in the normal and correct operation of the test method, exceed the following value only in one case in twenty:

range 777,0 to 892,0 kg/m³: 0,7 kg/m³ for density;

range 0,777 0 to 0,892 0: 0,000 7 g/ml for density or 0,000 7 for relative density.

11.2.3 Reproducibility

The difference between two single and independent test results, obtained by different operators working in different laboratories on identical test material, would in the long run, in the normal and correct operation of the test method, exceed the following value only in one case in twenty:

range 777,0 to 892,0 kg/m³: 1,0 kg/m³ for density;

range 0,777 0 to 0,892 0: 0,001 0 g/ml for density or 0,001 0 for relative density.

12 Test report

Report the final result either as density, to the nearest 0,1 kg/m³, or the nearest 0,000 1 g/ml, or as relative density to the nearest 0,000 1. Additionally, the following shall be included in the report:

- a) whether the value reported is density or relative density;
- b) if it is density, the unit and temperature (see 3.1);
- c) if it is relative density, the temperatures t_1 and t_2 (see 3.4);
- d) the method used for the determination;
- e) a reference to this International Standard, or to an identical national standard.

If the density reported has been corrected from the observed density using the tables referred to in 10.3.4, the reference temperature and the designation of the table used shall also be reported.

Table 3 — Density of air-free water, in kg/m³, against temperature in °C of the International Temperature Scale 1990 (Patterson & Morris Equation)

°C	0,0	0,1	0,2	0,3	0,4	0,5	0,6	0,7	0,8	0,9	Air correction
1	999,901 2	999,906 1	999,910 8	999,915 3	999,919 6	999,923 7	999,927 7	999,931 6	999,935 2	999,938 7	- 0,004 5
2	999,942 0	999,945 1	999,948 1	999,950 9	999,953 6	999,956 0	999,958 3	999,960 5	999,962 5	999,964 3	- 0,004 3
3	999,965 9	999,967 4	999,968 8	999,969 9	999,970 9	999,971 8	999,972 4	999,973 0	999,973 3	999,973 5	- 0,004 2
4	999,973 6	999,973 5	999,973 2	999,972 8	999,972 2	999,971 4	999,970 5	999,969 5	999,968 3	999,966 9	- 0,004 1
5	999,965 4	999,963 7	999,961 9	999,959 9	999,957 8	999,955 5	999,953 0	999,950 4	999,947 7	999,944 8	- 0,004 0
6	999,941 8	999,938 6	999,935 2	999,931 7	999,928 1	999,924 3	999,920 4	999,916 3	999,912 1	999,907 7	- 0,003 9
7	999,903 2	999,898 5	999,893 7	999,888 8	999,883 7	999,878 4	999,873 0	999,867 5	999,861 8	999,856 0	- 0,003 8
8	999,850 0	999,843 9	999,837 7	999,831 3	999,824 8	999,818 1	999,811 3	999,804 4	999,797 3	999,790 1	- 0,003 7
9	999,782 7	999,775 3	999,767 6	999,759 9	999,751 9	999,743 9	999,735 7	999,727 4	999,719 0	999,710 4	- 0,003 6
10	999,701 7	999,692 8	999,683 8	999,674 7	999,665 4	999,656 1	999,646 5	999,636 9	999,627 1	999,617 2	- 0,003 5
11	999,607 2	999,597 0	999,586 7	999,576 2	999,565 7	999,555 0	999,544 2	999,533 2	999,522 1	999,510 9	- 0,003 4
12	999,499 6	999,488 1	999,476 5	999,464 8	999,453 0	999,441 0	999,428 9	999,416 7	999,404 3	999,391 9	- 0,003 3
13	999,379 3	999,366 5	999,353 7	999,340 7	999,327 6	999,314 4	999,301 1	999,287 6	999,274 0	999,260 3	- 0,003 2
14	999,246 5	999,232 6	999,218 5	999,204 3	999,190 0	999,175 6	999,161 1	999,146 4	999,131 6	999,116 7	- 0,003 1
15	999,101 7	999,086 5	999,071 3	999,055 9	999,040 4	999,024 8	999,009 1	998,993 2	998,977 3	998,961 2	- 0,003 0
16	998,945 0	998,928 7	998,912 3	998,895 8	998,879 1	998,862 4	998,845 5	998,828 5	998,811 4	998,794 2	- 0,002 9
17	998,776 8	998,759 4	998,741 8	998,724 2	998,706 4	998,688 5	998,670 5	998,652 4	998,634 2	998,615 8	- 0,002 8
18	998,597 4	998,578 8	998,560 2	998,541 4	998,522 5	998,503 5	998,484 4	998,465 2	998,445 9	998,426 5	- 0,002 7
19	998,406 9	998,387 3	998,367 5	998,347 7	998,327 7	998,307 6	998,287 5	998,267 2	998,246 8	998,226 3	- 0,002 5
20	998,205 7	998,185 0	998,164 2	998,143 3	998,122 2	998,101 1	998,079 9	998,058 6	998,037 1	998,015 6	- 0,002 4
21	997,993 9	997,972 2	997,950 3	997,928 4	997,906 3	997,884 2	997,861 9	997,839 6	997,817 1	997,794 5	- 0,002 3
22	997,771 9	997,749 1	997,726 2	997,703 3	997,680 2	997,657 0	997,633 8	997,610 4	997,587 0	997,563 4	- 0,002 2
23	997,539 7	997,516 0	997,492 1	997,468 1	997,444 1	997,419 9	997,395 7	997,371 3	997,346 9	997,322 3	- 0,002 1
24	997,297 7	997,272 9	997,248 1	997,223 2	997,198 1	997,173 0	997,147 8	997,122 5	997,097 1	997,071 5	- 0,002 0
25	997,045 9	997,020 2	996,994 4	996,968 6	996,942 6	996,916 5	996,890 3	996,864 1	996,837 7	996,811 2	- 0,001 9
26	996,784 7	996,758 1	996,731 3	996,704 5	996,677 6	996,650 6	996,623 5	996,596 3	996,569 0	996,541 6	- 0,001 8
27	996,514 1	996,486 5	996,458 9	996,431 1	996,403 3	996,375 4	996,347 4	996,319 2	996,291 0	996,262 7	- 0,001 7
28	996,234 4	996,205 9	996,177 3	996,148 7	996,119 9	996,091 1	996,062 2	996,033 2	996,004 1	995,974 9	- 0,001 6
29	995,945 6	995,916 3	995,886 8	995,857 3	995,827 6	995,797 9	995,768 1	995,738 2	995,708 2	995,678 2	- 0,001 5
30	995,648 0	995,617 8	995,587 4	995,557 0	995,526 5	995,495 9	995,465 3	995,434 5	995,403 7	995,372 7	- 0,001 4
31	995,341 7	995,310 6	995,279 4	995,248 2	995,216 8	995,185 3	995,153 8	995,122 2	995,090 5	995,058 7	- 0,001 3
32	995,026 9	994,994 9	994,962 9	994,930 7	994,898 5	994,866 3	994,833 9	994,801 4	994,768 9	994,736 3	- 0,001 2
33	994,703 6	994,670 8	994,637 9	994,605 0	994,571 9	994,538 8	994,505 6	994,472 3	994,439 0	994,405 5	- 0,001 1
34	994,372 0	994,338 4	994,304 7	994,270 9	994,237 1	994,203 1	994,169 1	994,135 0	994,100 8	994,066 6	- 0,001 0
35	994,032 2	993,997 8	993,963 3	993,928 7	993,894 1	993,859 3	993,824 5	993,789 6	993,754 6	993,719 6	- 0,000 8
36	993,684 4	993,649 2	993,613 9	993,578 5	993,543 1	993,507 5	993,471 9	993,436 2	993,400 4	993,364 6	- 0,000 7
37	993,328 7	993,292 7	993,256 6	993,220 4	993,184 2	993,147 8	993,111 5	993,075 0	993,038 4	993,001 8	- 0,000 6
38	992,965 1	992,928 3	992,891 4	992,854 5	992,817 5	992,780 4	992,743 2	992,706 0	992,668 7	992,631 3	- 0,000 5
39	992,593 8	992,556 3	992,518 6	992,480 9	992,443 1	992,405 3	992,367 4	992,329 4	992,291 3	992,253 1	- 0,000 4
40	992,214 9										- 0,000 4

NOTE 1 Values for the density of water are based on work by Patterson and Morris for density expressed on the temperature scale ITS-90 (Metrologia, **31**, pp. 277-288, 1994).

NOTE 2 Values for the correction of density for air-saturated water are based on an equation by Bignell (Metrologia, **19**, pp. 57-59, 1983).

Energy Institute

61. New Cavendish Street
London
W1G 7AR

Tel: +44 (0)20 7467 7100
Fax: +44 (0)20 7255 1472
www.energyinst.org.uk

Buying Parts of BS 2000

Orders for BS 2000 publications should be addressed to:

The Library at the Energy Institute

British Standards Institution — Customer services
389 Chiswick High Road
London
W4 4AL

Tel: +44 (0)20 8996 9001
Fax: +44 (0)20 8996 7001
www.bsi-global.com

Order hard copy standards securely via:
www.bsi-global.com/bsonline

Copyright

Copyright subsists in all BS 2000 publications. No part of this publication may be reproduced in any form without the prior permission in writing of BSI and the Energy Institute. Enquiries about copyright should be made to the Secretary of PTI/13 at the Energy Institute.



THE INSTITUTE
OF PETROLEUM