

Dental rotary instruments — Burs —

Part 1: Steel and carbide burs

The European Standard EN ISO 3823-1:1998 has the status of a
British Standard

ICS 11.060.20

National foreword

This British Standard is the English language version of EN ISO 3823-1:1998. It is identical with ISO 3823-1:1997. It supersedes BS 6828-3:1987 which is withdrawn.

The UK participation in its preparation was entrusted to Technical Committee CH/52, Dental instruments, which has the responsibility to:

- aid enquirers to understand the text;
- present to the responsible international/European committee any enquiries on the interpretation, or proposals for change, and keep the UK interests informed;
- monitor related international and European developments and promulgate them in the UK.

A list of organizations represented on this committee can be obtained on request to its secretary.

Cross-references

Attention is drawn to the fact that CEN and CENELEC Standards normally include an annex which lists normative references to international publications with their corresponding European publications. The British Standards which implement international or European publications referred to in this document may be found in the BSI Standards Catalogue under the section entitled "International Standards Correspondence Index", or by using the "Find" facility of the BSI Standards Electronic Catalogue.

A British Standard does not purport to include all the necessary provisions of a contract. Users of British Standards are responsible for their correct application.

Compliance with a British Standard does not of itself confer immunity from legal obligations.

Summary of pages

This document comprises a front cover, an inside front cover, pages i and ii, the EN ISO title page, page 2, the ISO title page, pages ii to iv, pages 1 to 30, an inside back cover and a back cover.

This standard has been updated (see copyright date) and may have had amendments incorporated. This will be indicated in the amendment table on the inside front cover.

This British Standard, having been prepared under the direction of the Health and Environment Sector Committee, was published under the authority of the Standards Committee and comes into effect on 15 February 1999

© BSI 05-1999

ISBN 0 580 30996 7

Amendments issued since publication

Amd. No.	Date	Comments

Contents

	Page
National foreword	Inside front cover
Foreword	2
Foreword	iv
Text of ISO 3823-1	1

English version

Dental rotary instruments — Burs —
Part 1: Steel and carbide burs

(ISO 3823-1:1997)

Instruments rotatifs dentaires — Fraises —
Partie 1: Fraises en acier et en carbure
(ISO 3823-1:1997)

Zahnärztliche rotierende Instrumente —
Bohrer —
Teil 1: Stahl- und Hartmetallbohrer
(ISO 3823-1:1997)

This European Standard was approved by CEN on 20 November 1998.

CEN members are bound to comply with the CEN/CENELEC Internal Regulations which stipulate the conditions for giving this European Standard the status of a national standard without any alteration. Up-to-date lists and bibliographical references concerning such national standards may be obtained on application to the Central Secretariat or to any CEN member.

This European Standard exists in three official versions (English, French, German). A version in any other language made by translation under the responsibility of a CEN member into its own language and notified to the Central Secretariat has the same status as the official versions.

CEN members are the national standards bodies of Austria, Belgium, Czech Republic, Denmark, Finland, France, Germany, Greece, Iceland, Ireland, Italy, Luxembourg, Netherlands, Norway, Portugal, Spain, Sweden, Switzerland and United Kingdom.

CEN

European Committee for Standardization
Comité Européen de Normalisation
Europäisches Komitee für Normung

Central Secretariat: rue de Stassart 36, B-1050 Brussels

Foreword

The text of the International Standard from Technical Committee ISO/TC 106 “*Dentistry*” of the International Organization for Standardization (ISO) has been taken over as an European Standard by Technical Committee CEN/TC 55 “*Dentistry*”, the secretariat of which is held by DIN.

This European Standard replaces EN 23823-1:1991.

This European Standard shall be given the status of a national standard, either by publication of an identical text or by endorsement, at the latest by May 1999, and conflicting national standards shall be withdrawn at the latest by May 1999.

According to the CEN/CENELEC Internal Regulations, the national standards organizations of the following countries are bound to implement this European Standard: Austria, Belgium, Czech Republic, Denmark, Finland, France, Germany, Greece, Iceland, Ireland, Italy, Luxembourg, Netherlands, Norway, Portugal, Spain, Sweden, Switzerland and the United Kingdom.

Endorsement notice

The text of the International Standard ISO 3823-1:1997 has been approved by CEN as a European Standard without any modification.

NOTE Normative references to International Standards are listed in Annex ZA (normative).

INTERNATIONAL
STANDARD

ISO
3823-1

Second edition
1997-08-01

Dental rotary instruments — Burs —

Part 1:
Steel and carbide burs

Instruments rotatifs dentaires — Fraises —

Partie 1: Fraises en acier et en carbure



Reference number
ISO 3823-1:1997(E)

Contents

	Page
Foreword	2
Introduction	1
1 Scope	1
2 Normative references	1
3 Classification	1
4 Symbols for dimensions	1
5 Requirements	2
6 Test procedure	24
7 Quality control	30
8 Marking	30
9 Packaging	30
Annex ZA (normative) Normative references to international publications with their relevant European publications	Inside back cover
Figure 1	3
Figure 2	4
Figure 3	5
Figure 4	6
Figure 5	7
Figure 6	8
Figure 7	9
Figure 8	10
Figure 9	11
Figure 10	12
Figure 11	13
Figure 12	14
Figure 13	15
Figure 14	16
Figure 15	17
Figure 16	18
Figure 17	19
Figure 18	20
Figure 19	21
Figure 20	21
Figure 21	22
Figure 22	23
Table 1 — Dimensions and number of blades	3
Table 2 — Dimensions and number of blades	4
Table 3 — Dimensions and number of blades	5
Table 4 — Dimensions and number of blades	6
Table 5 — Dimensions and number of blades	7
Table 6 — Dimensions and number of blades	8
Table 7 — Dimensions and number of blades	9
Table 8 — Dimensions and number of blades	10
Table 9 — Dimensions and number of blades	11
Table 10 — Dimensions and number of blades	12
Table 11 — Dimensions and number of blades	13
Table 12 — Dimensions and number of blades	14
Table 13 — Dimensions and number of blades	15
Table 14 — Dimensions and number of blades	16
Table 15 — Dimensions and number of blades	17

	Page
Table 16 — Dimensions and number of blades	18
Table 17 — Dimensions and number of blades	19
Table 18 — Dimensions and number of blades	20
Table 19 — Dimensions and number of blades	21
Table 20 — Dimensions and number of blades	21
Table 21 — Dimensions and number of blades	22
Table 22 — Dimensions and number of blades	23
Table 23 — Round head	24
Table 24 — Inverted cone head	25
Table 25 — Pear head	25
Table 26 — Straight fissure head	25
Table 27 — Straight fissure head with rounded end	25
Table 28 — Tapered fissure head	26
Table 29 — Tapered fissure head with rounded end	26
Table 30 — Wheel head	26
Table 31 — Round head, spherical	27
Table 32 — Inverted cone head	27
Table 33 — Pear head	27
Table 34 — Straight fissure head	28
Table 35 — Straight fissure head with rounded end	28
Table 36 — Tapered fissure head	28
Table 37 — Tapered fissure head with rounded end	29
Table 38 — Wheel head	29
Table 39 — Cylindrical with cross-cut	29
Table 40 — Tapered with cross-cut	29

Descriptors: Dentistry, dental equipment, dental rotary-cutting instruments, burrs (dental), classification, specifications, dimensions, marking, packaging, quality control.

Foreword

ISO (the International Organization for Standardization) is a worldwide federation of national standards bodies (ISO member bodies). The work of preparing International Standards is normally carried out through ISO technical committees. Each member body interested in a subject for which a technical committee has been established has the right to be represented on that committee. International organizations, governmental and non-governmental, in liaison with ISO, also take part in the work. ISO collaborates closely with the International Electrotechnical Commission (IEC) on all matters of electrotechnical standardization.

Draft International Standards adopted by the technical committees are circulated to the member bodies for voting. Publication as an International Standard requires approval by at least 75 % of the member bodies casting a vote.

International Standard ISO 3823-1 was prepared by Technical Committee ISO/TC 106, *Dentistry*, Subcommittee SC 4, *Dental instruments*.

This second edition cancels and replaces the first edition (ISO 3823-1:1986), which has been technically revised.

ISO 3823 consists of the following parts, under the general title *Dental rotary instruments — Burs*:

- *Part 1: Steel and carbide burs;*
- *Part 2: Steel and carbide finishing burs.*

Introduction

This International Standard is one of a series of standards relating to dental rotary instruments.

This second edition of ISO 3823-1 contains the updated specifications for tungsten carbide burs. The specifications for steel burs remain unchanged.

The various dimensional and other requirements specified for steel and carbide burs are those considered important to ensure the interchangeability and safe usage of these instruments in the practice of dentistry.

The nominal diameters of the working part listed in Table 1 to Table 22 comply with the diameters specified in ISO 2157. The diameter listed in the first column (preferred diameters) should be used.

Attention is drawn to ISO 6360, which specifies a 15-digit numbering system for the identification of dental rotary instruments of all types.

1 Scope

This part of ISO 3823 specifies dimensional and other relevant requirements for the 10 most commonly used shapes of steel and carbide burs, including a quality control for these instruments.

2 Normative references

The following standards contain provisions which, through reference in this text, constitute provisions of this part of ISO 3823. At the time of publication, the editions indicated were valid. All standards are subject to revision, and parties to agreements based on this part of ISO 3823 are encouraged to investigate the possibility of applying the most recent editions of the standards indicated below. Members of IEC and ISO maintain registers of currently valid International Standards.

ISO 1797-1:1992, *Dental rotary instruments — Shanks — Part 1: Shanks made of metals.*

ISO 2157:1992, *Dental rotary instruments — Nominal diameters and designation code number.*

ISO 3696:1987, *Water for analytical laboratory use — Specification and test methods.*

ISO 6360-1:1995, *Dental rotary instruments — Number coding system — Part 1: General characteristics.*

ISO 6360-2:1986, *Dental rotary instruments — Number coding system — Part 2: Shape and specific characteristics.*

ISO 8325:1985, *Dental rotary instruments — Test methods.*

3 Classification

Steel and carbide burs shall be classified, according to the material of the working part, into the following two types:

- Type 1: steel burs;
- Type 2: carbide burs.

4 Symbols for dimensions

For the purposes of this part of ISO 3823, the following symbols apply.

d_1 diameter of working part, head diameter;

d_2 neck diameter;

l_1 length of working part, head length;

l_2 overall length.

5 Requirements

5.1 Material

5.1.1 *Working part*

The working part shall be made of steel or tungsten carbide. The selection of the type of material and its treatment shall be left to the discretion of the manufacturer.

5.1.2 *Shank*

The material of the shank shall comply with ISO 1797-1.

5.2 Shape

The shape of the working part shall be as specified in Figure 1 to Figure 22.

Variations of the shape within the limited dimensions and the terms specified in the titles of the respective subclauses are permitted.

Testing shall be carried out in accordance with 6.1.

5.3 Dimensions of working part and number of blades

All dimensions are given in millimetres. The dimensions of the working part shall be as specified in the appropriate figures and tables. The number of blades shall be as specified in the respective tables.

Testing shall be carried out in accordance with 6.1.

5.3.1 Steel burs

5.3.1.1 Round head (spherical)

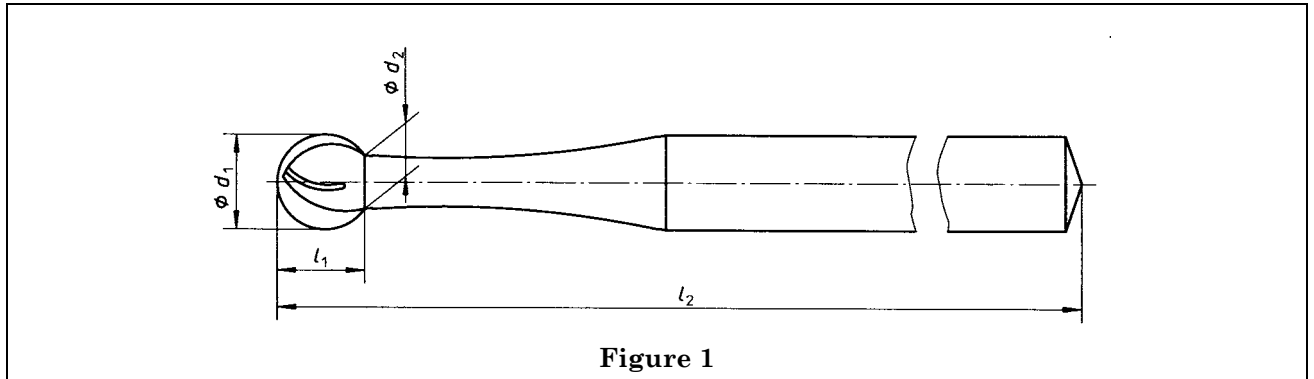

Table 1 — Dimensions and number of blades

Nominal diameter designation	d_1		d_2 max.	l_1 min.	Number of blades min.	l_2^a $\pm 0,5$			
	nom.	tol.				Shank type 1 Standard	Shank type 2 Standard	Shank type 3 Standard	Shank type 3 Short
006	0,6	$\pm 0,08$	0,48	0,46	6	22,0	44,5	19,0	16,5
008	0,8								
010	1,0								
012	1,2								
014	1,4								
016	1,6								
018	1,8								
021	2,1								
023	2,3								
025	2,5								
027	2,7								
029	2,9								
031	3,1								
033	3,3		$\pm 0,10$	1,78	2,72				
036	3,5	1,82		2,92	10				
037	3,7	1,92		3,09	10				
040	4,0	2,06		3,40	12				
042	4,2	2,16		3,51	12				
045	4,5	2,16		3,80	12				
047	4,7	2,24		3,97	12				
050	5,0	2,32		4,25	12				

^a The shank Type 1, 2 or 3 refers to the respective shanks of ISO 1797-1. "Standard" refers to instruments with standard fitting lengths of shank. For instruments with shorter or longer lengths of shank, the overall lengths l_2 vary accordingly. See ISO 1797-1, Table 1.

12:34,

5.3.1.2 Inverted cone head (inverted, truncated conical)

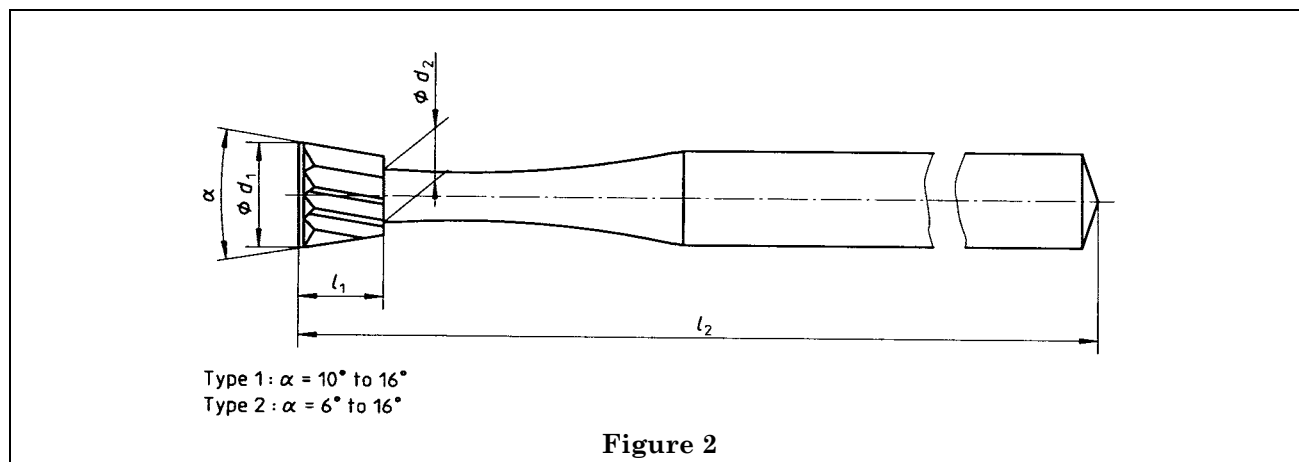

Table 2 — Dimensions and number of blades

Nominal diameter designation	d_1 ± 0,08	d_2 max.	l_1 min.	Number of blades min.	l_2^a ± 0,5			
					Shank type 1 Standard	Shank type 2 Standard	Shank type 3 Standard	Shank type 3 Short
006	0,6	0,48	0,42	6				
008	0,8	0,64	0,57	6				
010	1,0	0,78	0,71	6				
012	1,2	0,88	0,87	6				
014	1,4	0,98	1,00	6				
016	1,6	1,04	1,24	6				
018	1,8	1,12	1,44	6	22,0	44,5	19,0	16,5
021	2,1	1,20	1,66	6				
023	2,3	1,28	1,84	6				
025	2,5	1,40	2,00	10				
027	2,7	1,48	2,18	10				
029	2,9	1,60	2,33	10				
031	3,1	1,68	2,51	10				

^a See Table 1.

5.3.1.3 Pear head, regular and long (hemispherical, inverted conical)

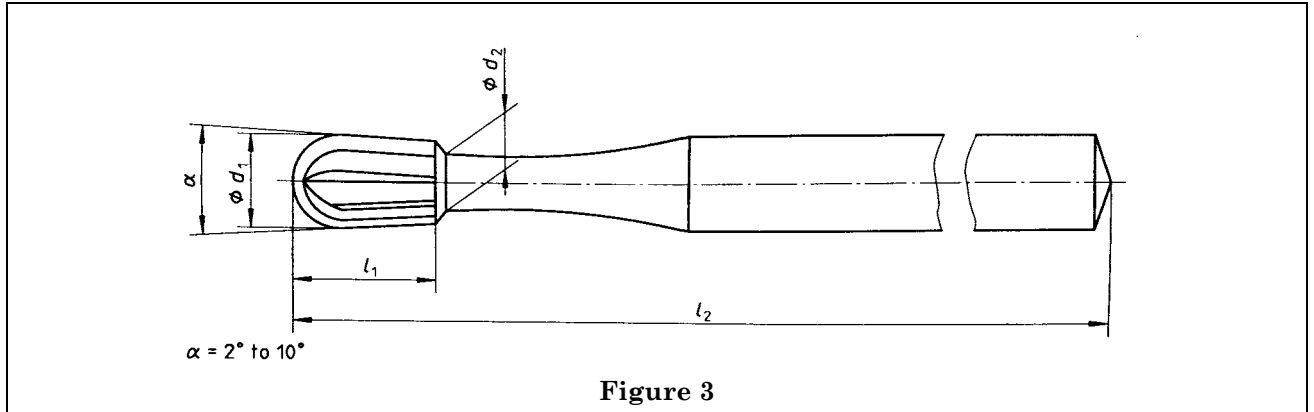

Table 3 — Dimensions and number of blades

Nominal diameter designation	d_1 ± 0,08	d_2 max.	l_1 min.		Number of blades min.	l_2^a ± 0,5			
			Regular	Long		Shank type 1 Standard	Shank type 2 Standard	Shank type 3 Standard	Shank type 3 Short
006	0,6	0,48	0,72	—	6				
008	0,8	0,64	0,97	—	6				
010	1,0	0,78	1,21	3,8	6				
012	1,2	0,88	1,47	3,8	6				
014	1,4	0,98	1,70	4,3	6				
016	1,6	1,04	2,04	4,3	6	22,0	44,5	19,0	16,5
018	1,8	1,12	2,34	4,8	6				
021	2,1	1,20	2,71	—	6				
023	2,3	1,28	2,99	—	6				
025	2,5	1,40	3,25	—	10				
027	2,7	1,48	3,53	—	10				
029	2,9	1,60	3,78	—	10				
031	3,1	1,68	4,06	—	10				

^a See Table 1.

5.3.1.4 Straight fissure head (cylindrical)

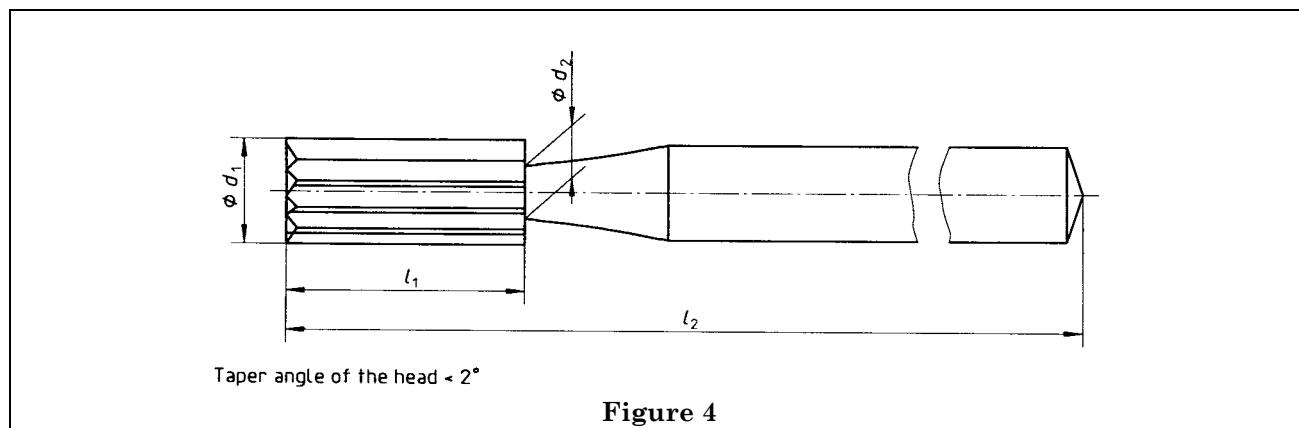

Table 4 — Dimensions and number of blades

Nominal diameter designation	d_1 $\pm 0,08$	d_2 max.	l_1 min.	Number of blades min.	l_2^a			
					Shank type 1 Standard	Shank type 2 Standard	Shank type 3 Standard	Shank type 3 Short
Regular								
006	0,6	0,68	2,8	6				
008	0,8	0,88	3,3	6				
010	1,0	1,08	3,8	6				
012	1,2	1,28	3,8	6				
014	1,4	1,35	4,3	6				
016	1,6	1,50	4,3	6				
018	1,8	1,60	4,8	6	22,0	44,5	19,0	16,5
021	2,1	1,70	4,8	6				
023	2,3	1,80	5,3	6				
025	2,5	1,85	5,3	10				
027	2,7	1,90	6,0	10				
029	2,9	2,00	6,0	10				
031	3,1	2,00	6,6	10				
Miniature								
008	0,8	0,88	3,0	6				
010	1,0	1,08	3,0	6				
012	1,2	1,28	3,0	6				
014	1,4	1,35	3,5	6				
016	1,6	1,50	3,5	6	22,0	44,5	19,0	16,5
018	1,8	1,60	3,5	6				
021	2,1	1,70	4,0	6				
023	2,3	1,80	4,0	6				

^a See Table 1.

5.3.1.5 Straight fissure head with rounded end (hemispherical, cylindrical)

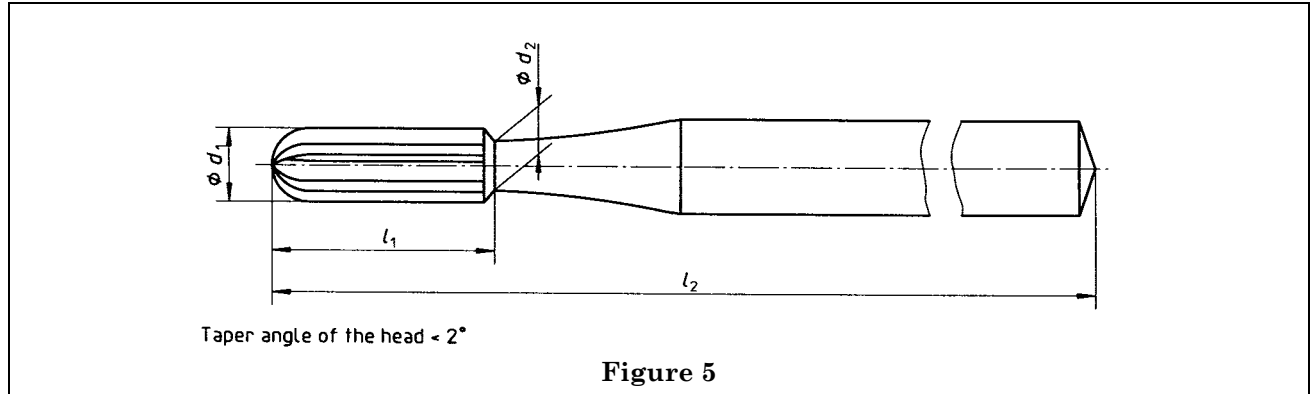

Table 5 — Dimensions and number of blades

Nominal diameter designation	d_1 $\pm 0,08$	d_2 max.	l_1 min.	Number of blades min.	l_2^a $\pm 0,5$			
					Shank type 1 Standard	Shank type 2 Standard	Shank type 3 Standard	Shank type 3 Short
006	0,6	0,68	2,8	6				
008	0,8	0,88	3,3	6				
010	1,0	1,08	3,8	6				
012	1,2	1,28	3,8	6				
014	1,4	1,35	4,3	6				
016	1,6	1,50	4,3	6				
018	1,8	1,60	4,8	6				
021	2,1	1,70	4,8	6	22,0	44,5	19,0	16,5
023	2,3	1,80	5,3	6				
025	2,5	1,85	5,3	10				
027	2,7	1,90	6,0	10				
029	2,9	2,00	6,0	10				
031	3,1	2,00	6,6	10				

^a See Table 1.

5.3.1.6 Tapered fissure head (truncated conical)

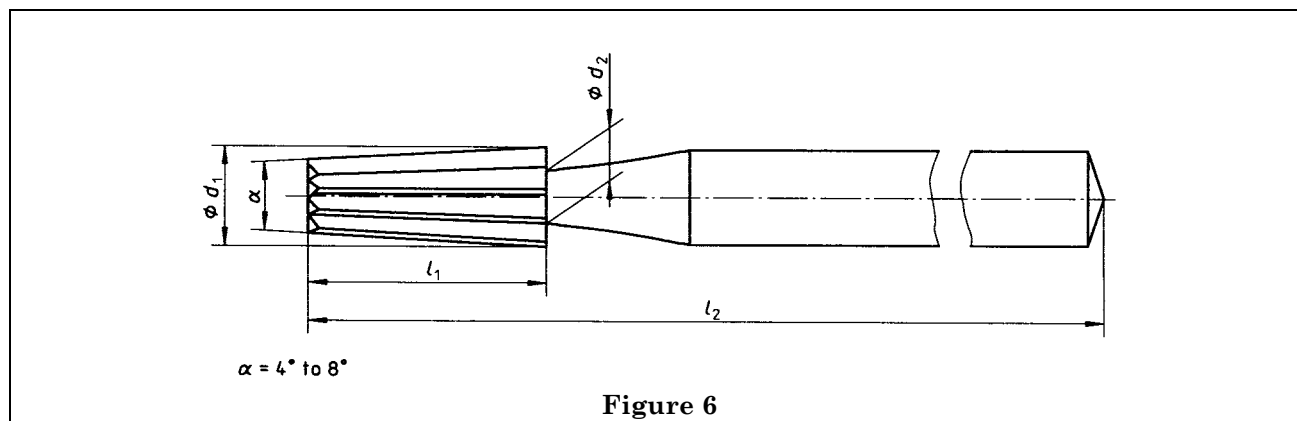

Figure 6

Table 6 — Dimensions and number of blades

Nominal diameter designation	d_1 $\pm 0,08$	d_2 max.	l_1 min.	Number of blades min.	l_2^a $\pm 0,5$			
					Shank type 1 Standard	Shank type 2 Standard	Shank type 3 Standard	Shank type 3 Short
Regular								
006	0,6	0,68	2,8	6				
008	0,8	0,88	3,3	6				
010	1,0	1,08	3,8	6				
012	1,2	1,28	3,8	6				
014	1,4	1,35	4,3	6				
016	1,6	1,50	4,3	6				
018	1,8	1,60	4,8	6	22,0	44,5	19,0	16,5
021	2,1	1,70	4,8	6				
023	2,3	1,80	5,3	6				
025	2,5	1,85	5,3	10				
027	2,7	1,90	6,0	10				
029	2,9	2,00	6,0	10				
031	3,1	2,00	6,6	10				
Miniature								
008	0,8	0,88	3,0	6				
010	1,0	1,08	3,0	6				
012	1,2	1,28	3,0	6				
014	1,4	1,35	3,5	6				
016	1,6	1,50	3,5	6	22,0	44,5	19,0	16,5
018	1,8	1,60	3,5	6				
021	2,1	1,70	4,0	6				
023	2,3	1,80	4,0	6				

^a See Table 1.

5.3.1.7 Tapered fissure head with rounded end, regular and long (truncated conical, domed)

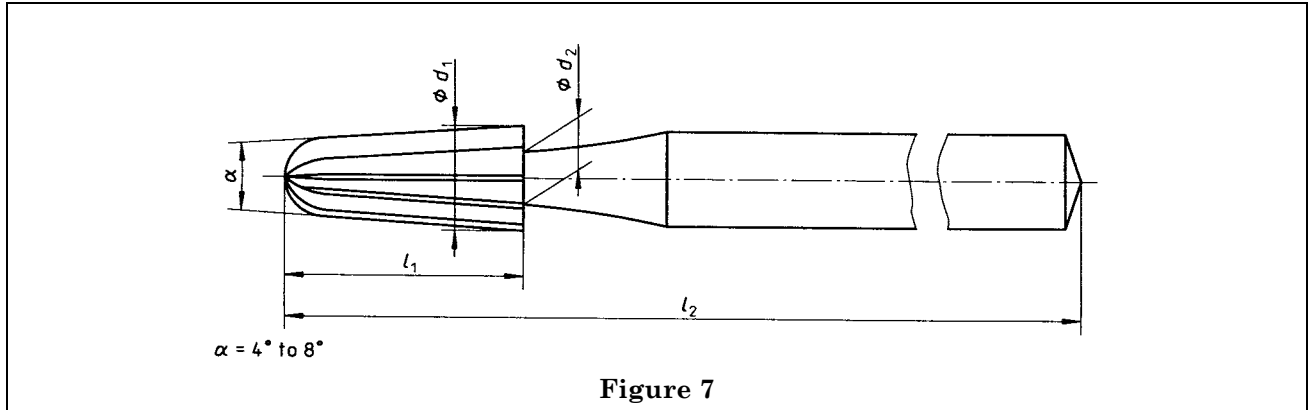

Table 7 — Dimensions and number of blades

Nominal diameter designation	d_1 $\pm 0,08$	d_2 max.	l_1 min.	Number of blades min.	l_2^a $\pm 0,5$			
					Shank type 1 Standard	Shank type 2 Standard	Shank type 3 Standard	Shank type 3 Short
006	0,6	0,68	2,8	6				
008	0,8	0,88	3,3	6				
010	1,0	1,08	3,8	6				
012	1,2	1,28	3,8	6				
014	1,4	1,35	4,3	6				
016	1,6	1,50	4,3	6				
018	1,8	1,60	4,8	6	22,0	44,5	19,0	16,5
021	2,1	1,70	4,8	6				
023	2,3	1,80	5,3	6				
025	2,5	1,85	5,3	10				
027	2,7	1,90	6,0	10				
029	2,9	2,00	6,0	10				
031	3,1	2,00	6,6	10				

^a See Table 1.

5.3.1.8 Wheel head (wheel)

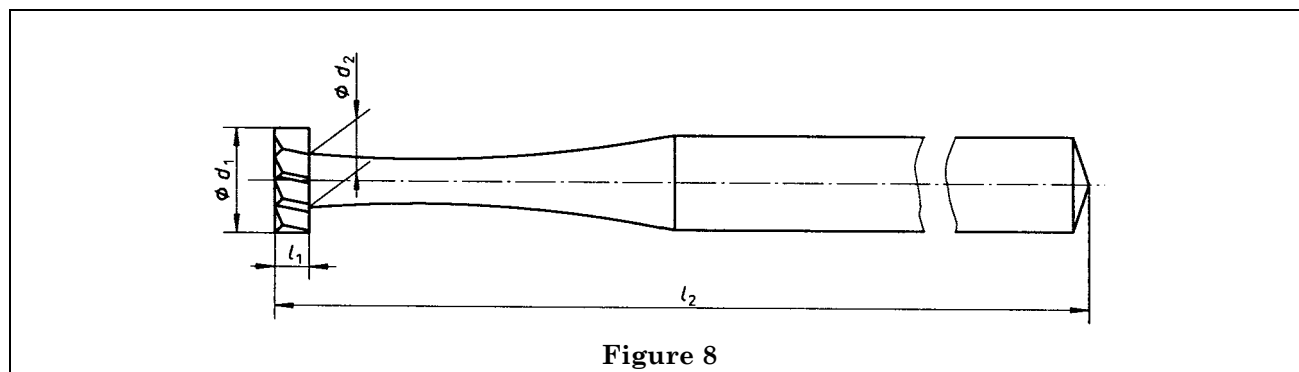

Figure 8

Table 8 — Dimensions and number of blades

Nominal diameter designation	d_1 $\pm 0,08$	d_2 max.	l_1 min.	Number of blades min.	l_2^a $\pm 0,5$			
					Shank type 1 Standard	Shank type 2 Standard	Shank type 3 Standard	Shank type 3 Short
006	0,6	0,48	0,19	6				
008	0,8	0,64	0,23	6				
010	1,0	0,78	0,26	6				
012	1,2	0,88	0,29	6				
014	1,4	0,98	0,32	6				
016	1,6	1,04	0,36	6				
018	1,8	1,12	0,42	6	22,0	44,5	19,0	16,5
021	2,1	1,20	0,48	6				
023	2,3	1,28	0,52	6				
025	2,5	1,40	0,57	10				
027	2,7	1,48	0,62	10				
029	2,9	1,60	0,66	10				
031	3,1	1,68	0,70	10				

^a See Table 1.

5.3.2 Carbide burs

5.3.2.1 Round head (spherical)

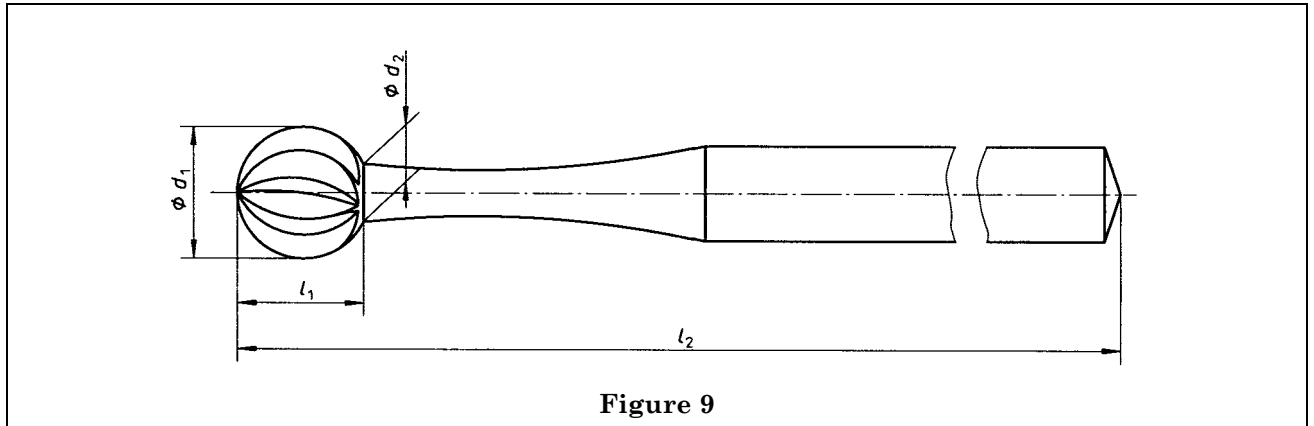

Table 9 — Dimensions and number of blades

Nominal diameter designation		d_1		d_2	l_1	Number of blades	l_2^a $\pm 0,5$			
Preferred diameter		nom.	tol.	max.	min.		min.	Shank type 1 Standard	Shank type 2 Standard	Shank type 3 Standard
005	—	0,5	$\pm 0,05$	0,41	0,30	6	22,0	44,5	19,0	16,5
006	—	0,6		0,48	0,40					
007	—	0,7		0,55	0,45					
008	—	0,8		0,64	0,50					
009	—	0,9		0,70	0,60					
010	—	1,0	$\pm 0,08$	0,78	0,65	8				
012	—	1,2		0,88	0,79					
014	—	1,4		0,98	0,82					
016	—	1,6		1,04	1,02					
018	—	1,8		1,20	1,26					
021	—	2,1		1,35	1,43					
023	—	2,3		1,45	1,60					
—	025	2,5	1,50	1,78	10					
—	027	2,7	1,55	1,85	8					
—	031	3,1	1,68	2,44	10					

^a See Table 1.

12:34,

5.3.2.2 Inverted cone head (inverted, truncated conical)

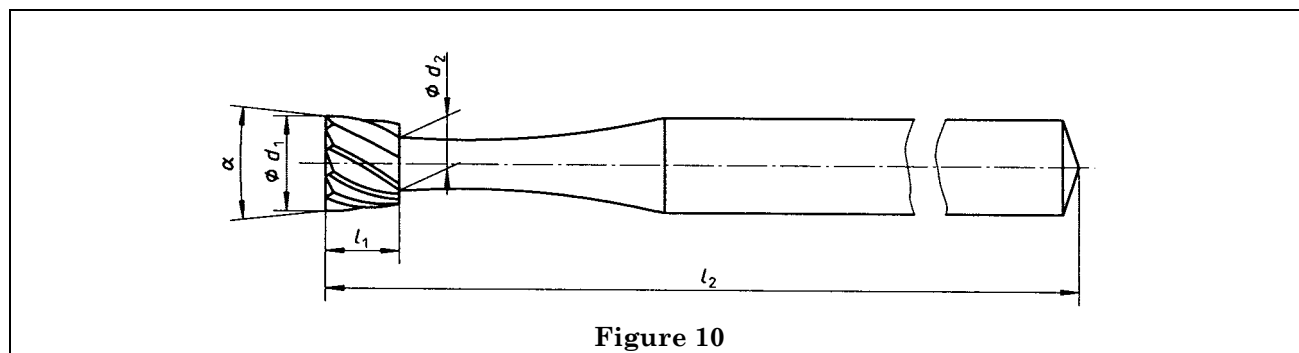

Figure 10

Table 10 — Dimensions and number of blades

Nominal diameter designation		d_1		d_2	α	l_1	Number of blades	l_2^a $\pm 0,5$			
		nom.	tol.					max.	min.	Shank type 1 Standard	Shank type 2 Standard
006	—	0,6	$\pm 0,05$	0,48	6° to 16°	0,34	6	22,0	44,5	19,0	16,5
008	—	0,8		0,64		0,45					
010	—	1,0	0,78	0,60							
012	—	1,2	0,88	0,70							
014	—	1,4	0,98	0,80							
016	—	1,6	1,05	1,10							
018	—	1,8	1,20	1,30							
—	021	2,1	1,35	1,54							
—	023	2,3	1,45	1,65							

^a See Table 1.

5.3.2.3 Pear head (hemispherical, inverted conical)

5.3.2.3.1 Head length regular

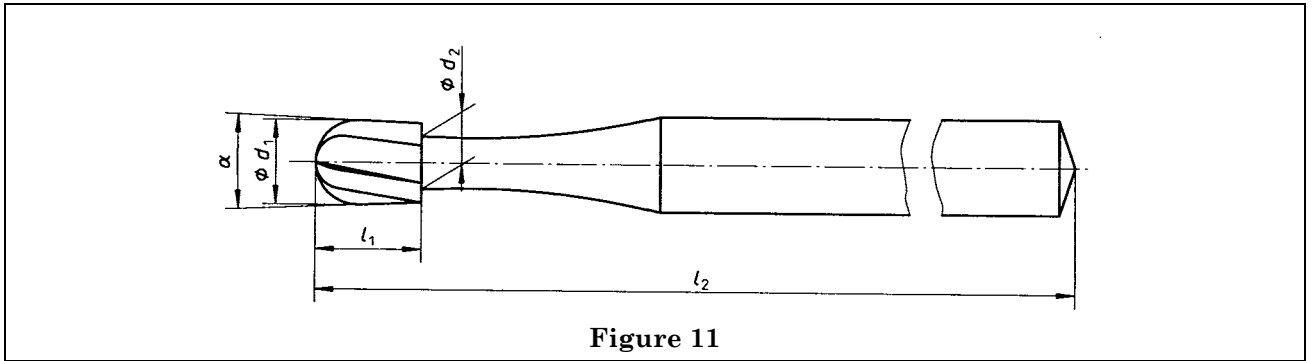

Table 11 — Dimensions and number of blades

Nominal diameter designation		d_1		d_2	α	l_1	Number of blades	l_2^a $\pm 0,5$			
Preferred diameter		nom.	tol.	max.		min.		min.	Shank type 1 Standard	Shank type 2 Standard	Shank type 3 Standard
006	—	0,6	$\pm 0,05$	0,48	2° to 10°	0,6	6	22,0	44,5	19,0	16,5
008	—	0,8		0,64		0,9					
009	—	0,9		0,70		1,0					
010	—	1,0	$\pm 0,08$	0,78		1,1					
012	—	1,2		0,88		1,3					
014	—	1,4		0,98		1,5					
—	016	1,6		1,04		1,8					
—	018	1,8		1,12		2,1					
—	021	2,1	1,20	2,4							

^a See Table 1.

5.3.2.3.2 Head length long

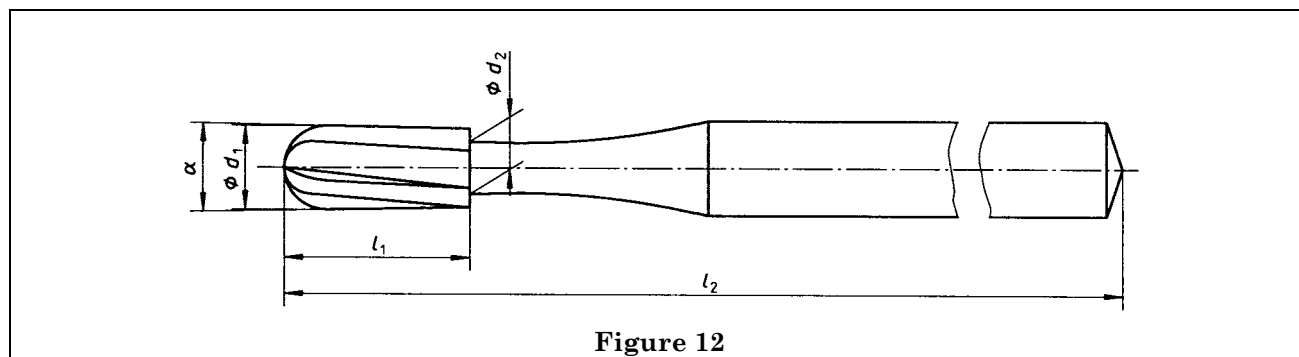

Figure 12

Table 12 — Dimensions and number of blades

Nominal diameter designation		d_1		d_2	α	l_1	Number of blades	l_2^a $\pm 0,5$			
Preferred diameter		nom.	tol.	max.		min.		Shank type 1 Standard	Shank type 2 Standard	Shank type 3 Standard	Shank type 3 Short
—	008	0,8	$\pm 0,05$	0,64	2° to 10°	1,4	6	22,0	44,5	19,0	16,5
010	—	1,0	$\pm 0,08$	0,78		3,7					
012	—	1,2		0,88		4,0					
014	—	1,4		0,98							
—	016	1,6		1,04							
—	018	1,8		1,12							

^a See Table 1.

5.3.2.4 Straight fissure head (cylindrical)

5.3.2.4.1 Head length regular

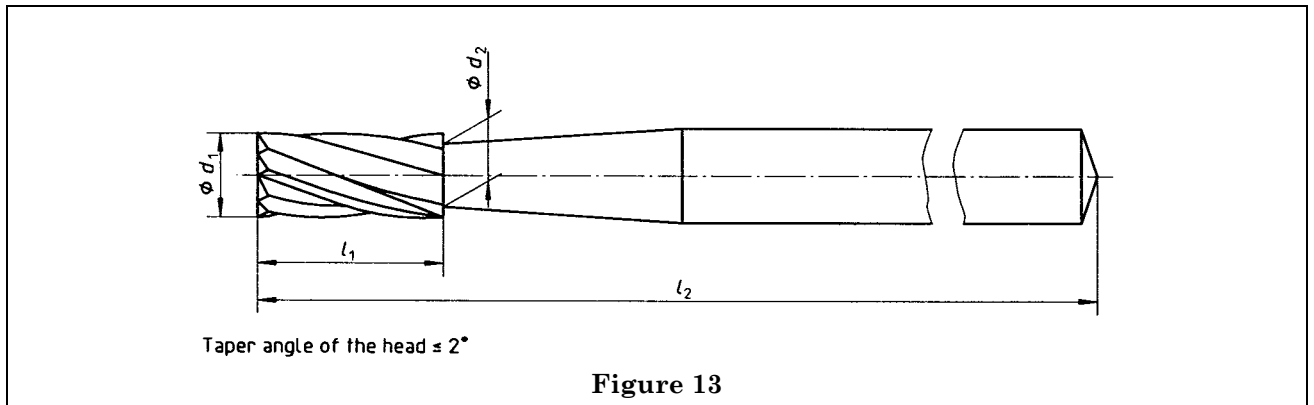

Table 13 — Dimensions and number of blades

Nominal diameter designation		d_1		d_2 max.	l_1 min.	Number of blades min.	l_2^a $\pm 0,5$			
		nom.	tol.				Shank type 1 Standard	Shank type 2 Standard	Shank type 3 Standard	Shank type 3 Short
008	—	0,8	$\pm 0,05$	0,80	3,2	6	22,0	44,5	19,0	16,5
—	009	0,9		0,90						
010	—	1,0	$\pm 0,08$	1,00	3,7					
012	—	1,2		1,20						
014	—	1,4		1,35						
016	—	1,6		1,50						
018	—	1,8	4,0	1,60	4,5					
—	021	2,1		1,80						

^a See Table 1.

5.3.2.4.2 Head length miniature

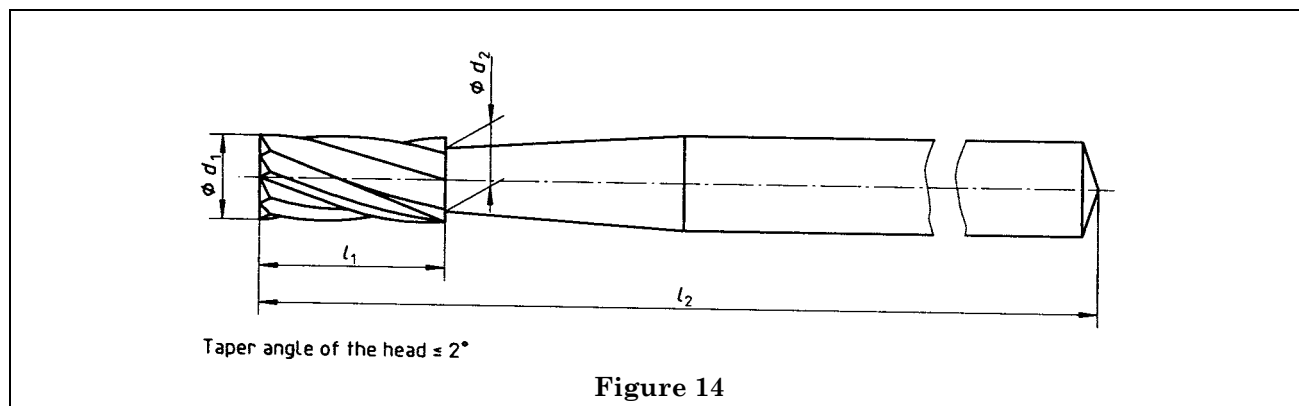

Table 14 — Dimensions and number of blades

Nominal diameter designation		d_1		d_2	l_1	Number of blades	l_2^a $\pm 0,5$			
Preferred diameter		nom.	tol.	max.	min.		min.	Shank type 1 Standard	Shank type 2 Standard	Shank type 3 Standard
—	008	0,8	$\pm 0,05$	0,80	2,9	6	22,0	44,5	19,0	16,5
—	010	1,0		1,00						
—	012	1,2	1,20							
—	016	1,4	$\pm 0,08$	1,35	3,3					
—	018	1,6		1,50						
—	021	1,8		1,60						
—	021	2,1		1,80	3,7					
—	023	2,3	1,85							

^a See Table 1.

12:34,

5.3.2.5 Straight fissure head with rounded end (hemispherical, cylindrical)

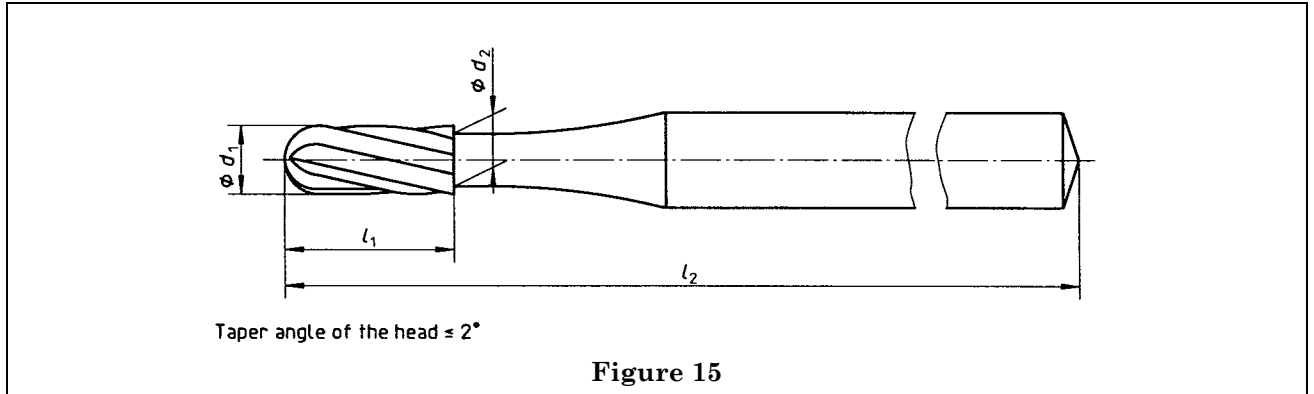

Table 15 — Dimensions and number of blades

Nominal diameter designation		d_1		d_2	l_1	Number of blades	$l_2^a \pm 0,5$			
		nom.	tol.				max.	min.	min.	Shank type 1 Standard
—	008	0,8	$\pm 0,05$	0,80	3,2	6	22,0	44,5	19,0	16,5
—	009	0,9		0,90						
010	—	1,0	1,00	3,7						
012	—	1,2								
014	—	1,4	1,35	4,0						
—	016	1,6								
—	018	1,8	1,50	4,5						
	021	2,1								

^a See Table 1.

5.3.2.6 Tapered fissure head (truncated conical)

5.3.2.6.1 Head length regular

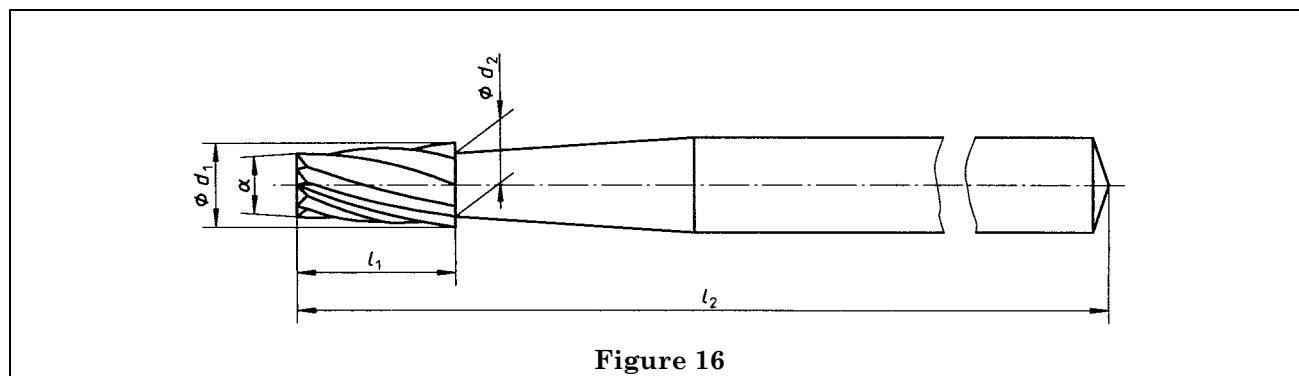

Figure 16

Table 16 — Dimensions and number of blades

Nominal diameter designation		d_1		d_2	α	l_1	Number of blades	l_2^a $\pm 0,5$			
Preferred diameter		nom.	tol.	max.		min.		Shank type 1 Standard	Shank type 2 Standard	Shank type 3 Standard	Shank type 3 Short
008	—	0,8	$\pm 0,05$	0,80	4° to 8°	3,2	6	22,0	44,5	19,0	16,5
—	009	0,9		0,90		3,7					
010	—	1,0	$\pm 0,08$	1,00		4,0					
012	—	1,2		1,20		4,5					
014	—	1,4		1,35							
016	—	1,6		1,50							
018	—	1,8		1,60							
—	021	2,1		1,80							

^a See Table 1.

5.3.2.6.2 Head length miniature

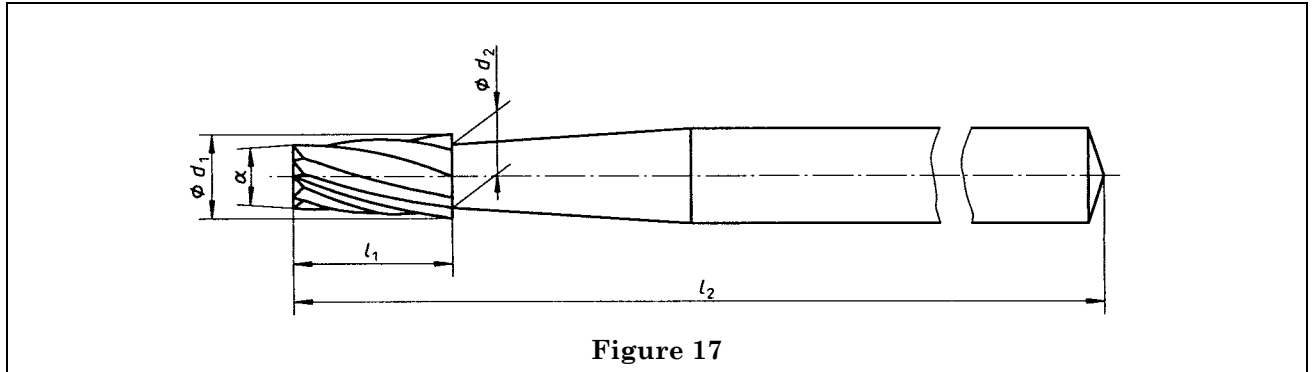

Figure 17

Table 17 — Dimensions and number of blades

Nominal diameter designation		d_1		d_2	α	l_1	Number of blades	l_2^a $\pm 0,5$			
Preferred diameter		nom.	tol.	max.		min.		min.	Shank type 1 Standard	Shank type 2 Standard	Shank type 3 Standard
—	008	0,8	$\pm 0,05$	0,80	4° to 8°	2,9	6	22,0	44,5	19,0	16,5
—	010	1,0	$\pm 0,08$	1,00							
—	012	1,2		1,20							
—	014	1,4		1,35							
—	016	1,6		1,50							
—	018	1,8		1,50							
—	021	2,1		1,80							
—	023	2,3		1,85							
							3,7				

^a See Table 1.

5.3.2.7 Tapered fissure head with rounded end (truncated conical, domed)

5.3.2.7.1 Head length regular

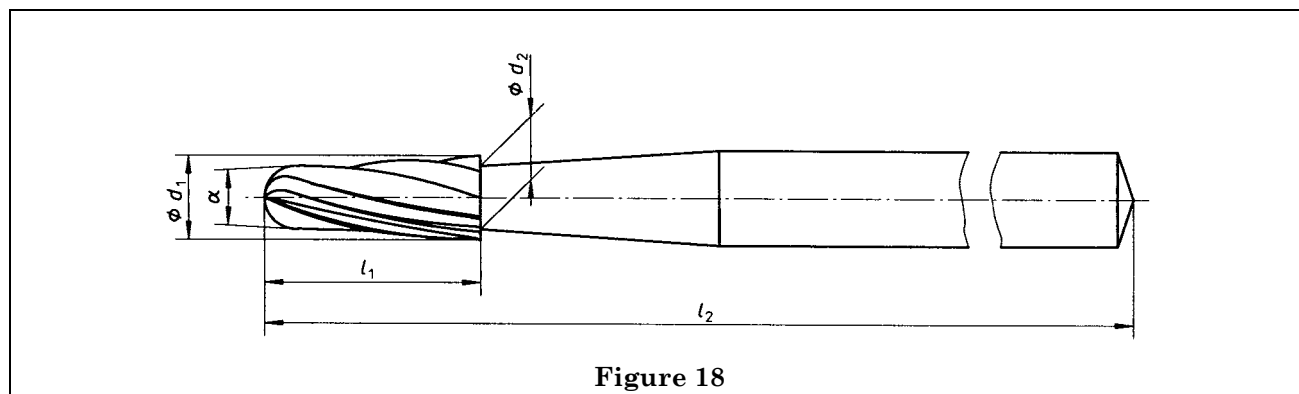

Figure 18

Table 18 — Dimensions and number of blades

Nominal diameter designation		d_1		d_2	α	l_1	Number of blades	l_2^a $\pm 0,5$			
Preferred diameter		nom.	tol.	max.		min.		Shank type 1 Standard	Shank type 2 Standard	Shank type 3 Standard	Shank type 3 Short
—	008	0,8	$\pm 0,05$	0,80	4° to 8°	3,2	6	22,0	44,5	19,0	16,5
—	009	0,9		0,90		3,7					
010	—	1,0	1,00	4,0							
012	—	1,2	1,20	4,5							
014	—	1,4	1,35								
016	—	1,6	1,50								
—	018	1,8	1,60								
—	021	2,1	1,80								

^a See Table 1.

5.3.2.7.2 Head length long

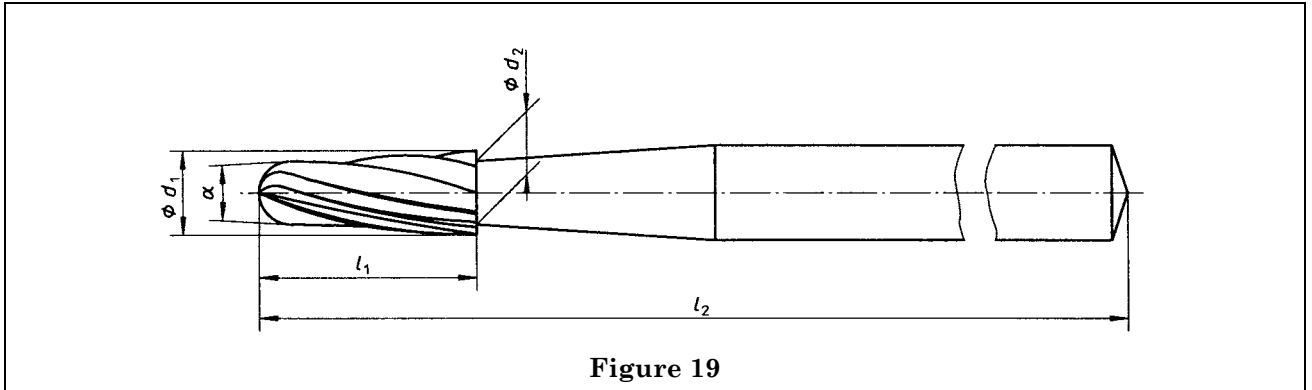

Table 19 — Dimensions and number of blades

Nominal diameter designation		d_1	d_2	α	l_1	Number of blades	l_2^a $\pm 0,5$			
Preferred diameter		$\pm 0,08$	max.		min.		Shank type 1 Standard	Shank type 2 Standard	Shank type 3 Standard	Shank type 3 Short
—	010	1,0	1,00	4° to 8°	3,7	6	22,0	44,5	19,0	16,5
—	012	1,2	1,20							

^a See Table 1.

5.3.2.8 Wheel head (wheel)

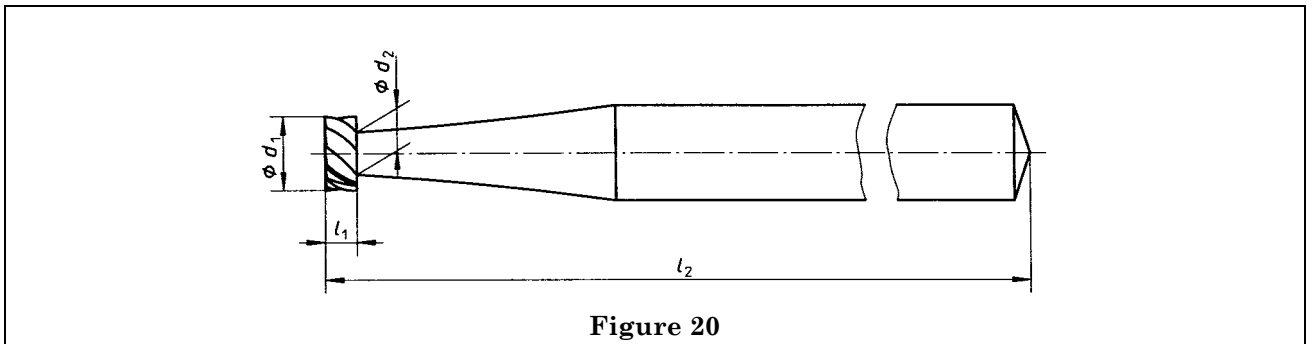

Table 20 — Dimensions and number of blades

Nominal diameter designation		d_1	d_2	l_1	Number of blades	l_2^a $\pm 0,5$			
Preferred diameter		$\pm 0,08$	max.	min.		min.	Shank type 1 Standard	Shank type 2 Standard	Shank type 3 Standard
—	012	1,2	0,88	0,21	6	22,0	44,5	19,0	16,5

^a See Table 1.

5.3.2.9 Cylindrical with cross-cut

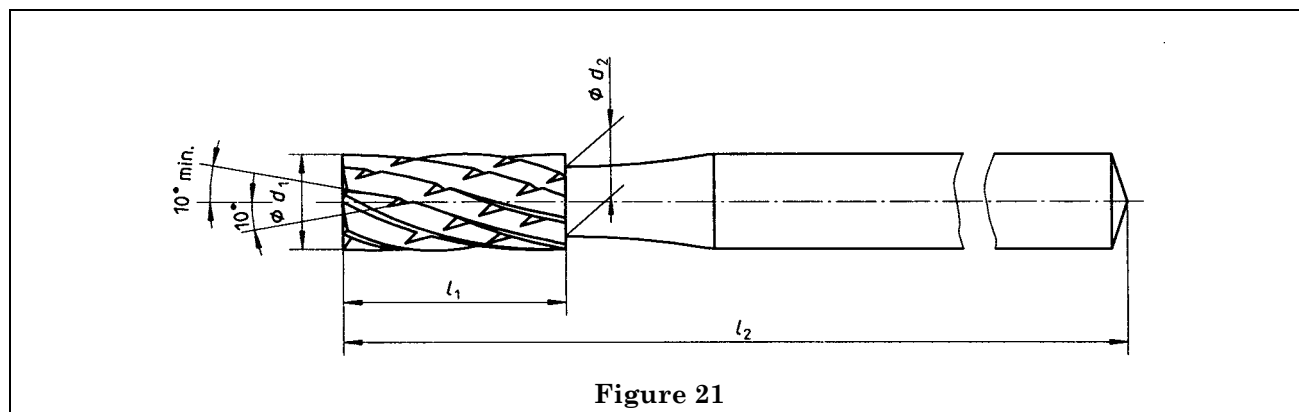

Table 21 — Dimensions and number of blades

Nominal diameter designation		d_1	d_2	l_1	Number of blades ^a	l_2^b $\pm 0,5$			
Preferred diameter		$\pm 0,08$	max.	min.		Shank type 1 Standard	Shank type 2 Standard	Shank type 3 Standard	Shank type 3 Short
010	—	1,0	1,00	3,7	6	22,0	44,5	19,0	16,5
012	—	1,2	1,20						
—	014	1,4	1,35	4,0					
—	016	1,6	1,50						
—	018	1,8	1,60	4,5					
—	021	2,1	1,80						
—	023	2,3	1,85						

^a Spiral left and right each.
^b See Table 1.

12:34,

5.3.2.10 Tapered with cross-cut

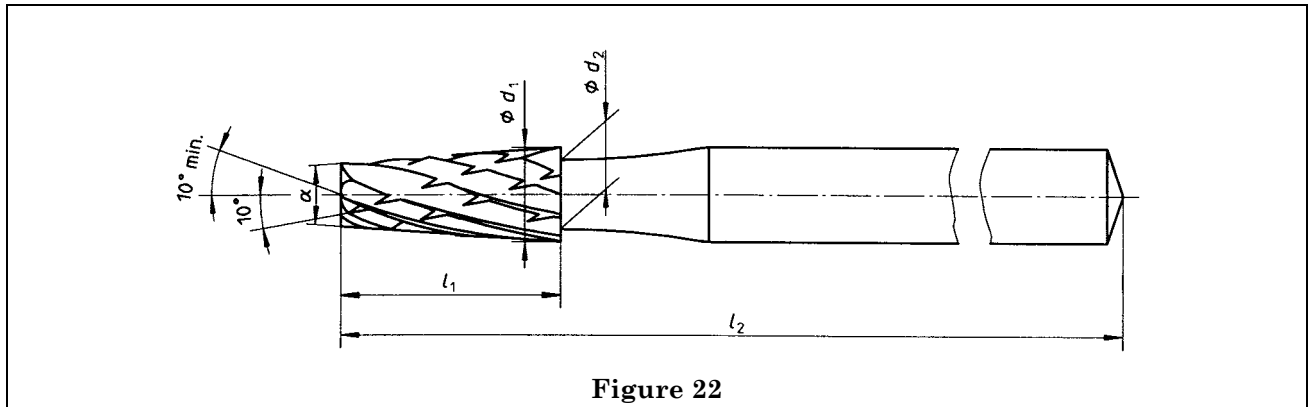

Figure 22

Table 22 — Dimensions and number of blades

Nominal diameter designation	Preferred diameter	d_1	d_2	α	l_1	Number of blades ^a	l_2^b $\pm 0,5$			
		$\pm 0,08$	max.		min.		min.	Shank type 1 Standard	Shank type 2 Standard	Shank type 3 Standard
—	010	1,0	1,00	4° to 8°	3,7	6	22,0	44,5	19,0	16,5
012	—	1,2	1,20							
—	014	1,4	1,35		4,0					
—	016	1,6	1,50							
—	018	1,8	1,60		4,5					
—	021	2,1	1,70							
—	023	2,3	1,85							

^a Spiral left and right each.
^b See Table 1.

5.4 Dimensions of shank

The shank shall be Type 1, 2 or 3 of ISO 1797-1.

5.5 Run-out

The total indicated run-out shall not exceed the following values:

- for steel burs: 0,08 mm;
- for carbide burs: 0,05 mm.

Testing shall be carried out in accordance with 6.2.

5.6 Corrosion resistance

Steel and carbide burs, if declared corrosion-resistant (or any similar term), shall not show signs of corrosion or functional deterioration after testing. For carbide burs, a slight galvanic corrosion is permitted at the junction of the neck to the carbide working part.

Testing shall be carried out in accordance with 6.3.

5.7 Neck strength

The instrument shall not fracture or take a permanent set exceeding:

- for steel burs: 0,08 mm;
- for carbide burs: 0,05 mm.

Testing shall be carried out after the corrosion test and in accordance with 6.4.

12:34,

6 Test procedure

6.1 Shapes, dimensions and number of blades

Measure and/or determine the shapes and the dimensions in accordance with ISO 8325:1985, 3.1 to 3.5 respectively, as appropriate.

Determine the number of blades by visual inspection.

6.2 Run-out

Determine the run-out in accordance with ISO 8325:1985, 3.6.

The measurement point shall be the largest diameter just behind the working part.

6.3 Corrosion resistance

6.3.1 Equipment

Autoclave, operating in the non-vacuum mode, capable of being operated at 134 °C to 138 °C and 0,22 M·N m⁻² (2,2 bar).

6.3.2 Reagent

Distilled or deionized water, grade 3 in accordance with ISO 3696.

6.3.3 Preparation of test piece

Scrub the test piece using soap and warm water. Rinse thoroughly in water (6.3.2) and dry.

6.3.4 Procedure

Place the unwrapped test piece in the autoclave. Using the water (6.3.2) subject the test piece to an autoclaving cycle of $(3^{+0,5}_0)$ min at 134 °C to 138 °C, and 0,22 M·N m⁻². After the cycle, open the door.

Remove the test piece and allow to cool to room temperature.

6.3.5 Evaluation

Visually inspect the test piece at normal visual acuity for any signs of corrosion.

Functional deterioration is determined after testing the neck strength, see 6.4.

6.4 Neck strength

Determine the neck strength in accordance with ISO 8325:1985, 3.7 and after the test for corrosion resistance.

For the test load F , use the appropriate value specified in Table 23 to Table 40. These tables cover the values for the most commonly used sizes of bur. The appropriate test load F for other sizes may be calculated using the equation given in ISO 8325.

6.4.1 Test loads F for steel burs

Table 23 — Round head

Values in newtons

Nominal diameter	F
006	7,36
008	13,24
010	19,12
012	23,35
014	28,84
016	30,12
018	32,96
021	35,90
023	39,73

Table 24 — Inverted cone head

Values in newtons

Nominal diameter	<i>F</i>
006	7,65
008	13,64
010	19,52
012	24,03
014	29,04
016	29,53
018	32,67
021	35,02

Table 25 — Pear head

Values in newtons

Nominal diameter	<i>F</i>	
	Regular head	Long head
006	6,37	—
008	10,88	9,02
010	16,08	8,43
012	19,71	11,47
014	23,74	14,22
016	24,81	16,28
018	27,36	18,54
021	29,72	—

Table 26 — Straight fissure head

Values in newtons

Nominal diameter	<i>F</i>	
	Regular head	Miniature head
008	10,39	11,08
010	17,16	20,01
012	27,76	31,98
014	31,68	39,82
016	45,91	51,69
018	52,67	62,19
021	57,97	64,25
023	—	73,28

**Table 27 — Straight fissure head
with rounded end**

Values in newtons

Nominal diameter	<i>F</i>
008	10,39
010	17,16
012	27,76
014	35,21
016	45,91
018	52,67
021	57,97

Table 28 — Tapered fissure head

Values in newtons

Nominal diameter	<i>F</i>	
	Regular head	Miniature head
008	10,39	11,08
010	17,16	20,01
012	27,76	31,98
014	36,21	39,82
016	45,91	51,69
018	52,67	62,19
021	57,97	64,25
023	—	73,28

Table 29 — Tapered fissure head with rounded end

Values in newtons

Nominal diameter	<i>F</i>	
	Regular head	Long head
008	10,39	—
010	17,16	14,12
012	27,76	23,15
014	35,21	—
016	45,91	—
018	52,67	—
021	57,97	—

Table 30 — Wheel head

Values in newtons

Nominal diameter	<i>F</i>
012	29,13

6.4.2 Test loads F for carbide burs

Table 31 — Round head, spherical

Values in newtons

Nominal diameter	F
005	5,23
006	7,33
007	9,60
008	13,26
009	15,30
010	19,16
012	23,29
014	28,85
016	30,15
018	39,79
021	49,46
023	55,90
025	57,28
027	59,89
031	64,43

Table 32 — Inverted cone head

Values in newtons

Nominal diameter	F
006	7,64
008	13,61
010	19,56
012	24,05
014	29,04
016	30,28
018	39,42
021	48,37
023	55,38

Table 33 — Pear head

Values in newtons

Nominal diameter	F	
	Regular head	Long head
006	6,46	—
008	10,99	9,06
009	12,94	—
010	16,16	8,50
012	19,78	12,33
014	23,80	22,78
016	24,85	34,73
018	27,45	46,54
021	29,74	—

Table 34 — Straight fissure head (cylindrical)

Values in newtons

Nominal diameter	<i>F</i>	
	Regular head	Miniature head
008	10,46	11,16
009	14,30	—
010	17,21	20,02
012	27,79	31,98
014	35,24	39,89
016	45,98	51,73
018	50,86	59,97
021	68,11	75,28
023	—	79,13

Table 35 — Straight fissure head with rounded end (hemispherical, cylindrical)

Values in newtons

Nominal diameter	<i>F</i>
008	10,46
009	14,30
010	17,21
012	27,79
014	35,24
016	45,98
018	50,86
021	68,11

Table 36 — Tapered fissure head (truncated conical)

Values in newtons

Nominal diameter	<i>F</i>	
	Regular head	Miniature head
008	10,46	11,16
009	14,30	—
010	17,21	20,02
012	27,79	31,98
014	35,24	39,89
016	45,98	51,73
018	50,86	59,97
021	68,11	75,28
023	—	79,13

Table 37 — Tapered fissure head with rounded end
(truncated conical, domed)

Values in newtons

Nominal diameter	<i>F</i>	
	Regular head	Long head
008	10,46	—
009	14,30	—
010	17,21	14,22
012	27,79	23,22
014	35,24	—
016	45,98	—
018	50,86	—
021	68,11	—

Table 38 — Wheel head (wheel)

Values in newtons

Nominal diameter	<i>F</i>
012	29,19

Table 39 — Cylindrical with cross-cut

Values in newtons

Nominal diameter	<i>F</i>
010	17,21
012	27,79
014	35,24
016	45,98
018	50,86
021	68,11
023	71,81

Table 40 — Tapered with cross-cut

Values in newtons

Nominal diameter	<i>F</i>
010	17,21
012	27,79
014	35,24
016	45,98
018	50,86
021	68,11
023	71,81

7 Quality control

7.1 Sampling

Use a sample size of between 100 and 150 burs, containing at least 20 burs of each of a minimum of five different bur sizes. All three types of shank shall be included. Check 20 burs for each possible defect. The sample group is considered acceptable if no more than three of the 20 burs are rejected. If four or more burs fail the requirements for any given possible defect, the batch from which the samples were drawn does not comply with the specified requirement.

7.2 Acceptable quality level (AQL)

The acceptable quality level, expressed as the maximum acceptable number of defects per 100 pieces, shall be 6,5 max.

The defects are as follows:

- a) total indicated run-out exceeds the values specified;
- b) head diameter does not conform to the diameter specified;
- c) neck diameter exceeds the maximum value specified;
- d) any combination of neck breakage, joint breakage or neck taking a permanent set at loads less than those specified;
- e) head length is below the minimum value specified;
- f) overall length does not conform to that specified.

8 Labelling

Labelling on the package of burs shall contain at least the following information:

- a) name and/or trademark of the manufacturer or distributor;
- b) material of the working part;
- c) type of shank, in accordance with ISO 1797;
- d) shape number;
- e) execution;
- f) size;
- g) lot number;
- h) the word, or symbol for “sterile”, if applicable.

The information shall be given in accordance with ISO 6360, if applicable.

9 Packaging

Steel and carbide burs shall be packaged at the discretion of the manufacturer.

Annex ZA (normative)

Normative references to international publications with their relevant European publications

This European Standard incorporates by dated or undated reference, provisions from other publications. These normative references are cited at the appropriate places in the text and the publications are listed hereafter. For dated references, subsequent amendments to or revisions of any of these publications apply to this European Standard only when incorporated in it by amendment or revision. For undated references the latest edition of the publication referred to applies.

<u>Publication</u>	<u>Year</u>	<u>Title</u>	<u>EN</u>	<u>Year</u>
ISO 1797-1	1992	Dental rotary instruments — Shanks — Part 1: Shanks made of metals	EN ISO 1797-1	1995
ISO 2157	1992	Dental rotary instruments — Nominal diameters and designation code number	EN ISO 2157	1995
ISO 3696	1987	Water for analytical laboratory use — Specification and test methods	EN ISO 3696	1995
ISO 6360-1	1995	Dentistry — Dental rotary instruments — Number coding system — Part 1: General characteristics	EN 26360-1	1990
ISO 6360-2	1986	Dentistry — Dental rotary instruments — Number coding system — Part 2: Shape and specific characteristics — Addendum 1	EN 26360-2	1991
ISO 8325	1985	Dentistry — Dental rotary instruments — Test methods	EN 28325	1990

BSI — British Standards Institution

BSI is the independent national body responsible for preparing British Standards. It presents the UK view on standards in Europe and at the international level. It is incorporated by Royal Charter.

Revisions

British Standards are updated by amendment or revision. Users of British Standards should make sure that they possess the latest amendments or editions.

It is the constant aim of BSI to improve the quality of our products and services. We would be grateful if anyone finding an inaccuracy or ambiguity while using this British Standard would inform the Secretary of the technical committee responsible, the identity of which can be found on the inside front cover.
Tel: 020 8996 9000. Fax: 020 8996 7400.

BSI offers members an individual updating service called PLUS which ensures that subscribers automatically receive the latest editions of standards.

Buying standards

Orders for all BSI, international and foreign standards publications should be addressed to Customer Services. Tel: 020 8996 9001. Fax: 020 8996 7001.

In response to orders for international standards, it is BSI policy to supply the BSI implementation of those that have been published as British Standards, unless otherwise requested.

Information on standards

BSI provides a wide range of information on national, European and international standards through its Library and its Technical Help to Exporters Service. Various BSI electronic information services are also available which give details on all its products and services. Contact the Information Centre.
Tel: 020 8996 7111. Fax: 020 8996 7048.

Subscribing members of BSI are kept up to date with standards developments and receive substantial discounts on the purchase price of standards. For details of these and other benefits contact Membership Administration.
Tel: 020 8996 7002. Fax: 020 8996 7001.

Copyright

Copyright subsists in all BSI publications. BSI also holds the copyright, in the UK, of the publications of the international standardization bodies. Except as permitted under the Copyright, Designs and Patents Act 1988 no extract may be reproduced, stored in a retrieval system or transmitted in any form or by any means – electronic, photocopying, recording or otherwise – without prior written permission from BSI.

This does not preclude the free use, in the course of implementing the standard, of necessary details such as symbols, and size, type or grade designations. If these details are to be used for any other purpose than implementation then the prior written permission of BSI must be obtained.

If permission is granted, the terms may include royalty payments or a licensing agreement. Details and advice can be obtained from the Copyright Manager.
Tel: 020 8996 7070.