



BSI Standards Publication

**Acoustics — Determination
of sound power levels and
sound energy levels of
noise sources using sound
pressure — Precision
methods for anechoic rooms
and hemi-anechoic rooms**

National foreword

This British Standard is the UK implementation of EN ISO 3745:2012. It supersedes BS EN ISO 3745:2009 which is withdrawn.

The UK participation in its preparation was entrusted to Technical Committee EH/1/4, Machinery noise.

A list of organizations represented on this committee can be obtained on request to its secretary.

This publication does not purport to include all the necessary provisions of a contract. Users are responsible for its correct application.

© The British Standards Institution 2012. Published by BSI Standards Limited 2012

ISBN 978 0 580 53881 0

ICS 17.140.01

Compliance with a British Standard cannot confer immunity from legal obligations.

This British Standard was published under the authority of the Standards Policy and Strategy Committee on 30 April 2012.

Amendments issued since publication

Date	Text affected
------	---------------

English Version

Acoustics - Determination of sound power levels and sound energy levels of noise sources using sound pressure - Precision methods for anechoic rooms and hemi-anechoic rooms (ISO 3745:2012)

Acoustique - Détermination des niveaux de puissance acoustique et des niveaux d'énergie acoustique émis par les sources de bruit à partir de la pression acoustique - Méthodes de laboratoire pour les salles anéchoïques et les salles semi-anéchoïques (ISO 3745:2012)

Akustik - Bestimmung der Schalleistungs- und Schallenergiepegel von Geräuschquellen aus Schalldruckmessungen - Verfahren der Genauigkeitsklasse 1 für reflexionsarme Räume und Halbräume (ISO 3745:2012)

This European Standard was approved by CEN on 14 March 2012.

CEN members are bound to comply with the CEN/CENELEC Internal Regulations which stipulate the conditions for giving this European Standard the status of a national standard without any alteration. Up-to-date lists and bibliographical references concerning such national standards may be obtained on application to the CEN-CENELEC Management Centre or to any CEN member.

This European Standard exists in three official versions (English, French, German). A version in any other language made by translation under the responsibility of a CEN member into its own language and notified to the CEN-CENELEC Management Centre has the same status as the official versions.

CEN members are the national standards bodies of Austria, Belgium, Bulgaria, Croatia, Cyprus, Czech Republic, Denmark, Estonia, Finland, France, Germany, Greece, Hungary, Iceland, Ireland, Italy, Latvia, Lithuania, Luxembourg, Malta, Netherlands, Norway, Poland, Portugal, Romania, Slovakia, Slovenia, Spain, Sweden, Switzerland, Turkey and United Kingdom.



EUROPEAN COMMITTEE FOR STANDARDIZATION
COMITÉ EUROPÉEN DE NORMALISATION
EUROPÄISCHES KOMITEE FÜR NORMUNG

Management Centre: Avenue Marnix 17, B-1000 Brussels

Foreword

This document (EN ISO 3745:2012) has been prepared by Technical Committee ISO/TC 43 "Acoustics" in collaboration with Technical Committee CEN/TC 211 "Acoustics" the secretariat of which is held by DS.

This European Standard shall be given the status of a national standard, either by publication of an identical text or by endorsement, at the latest by September 2012, and conflicting national standards shall be withdrawn at the latest by September 2012.

Attention is drawn to the possibility that some of the elements of this document may be the subject of patent rights. CEN [and/or CENELEC] shall not be held responsible for identifying any or all such patent rights.

This document supersedes EN ISO 3745:2009.

This document has been prepared under a mandate given to CEN by the European Commission and the European Free Trade Association, and supports essential requirements of EU Directive.

For relationship with EU Directive, see informative Annex ZA, which is an integral part of this document.

According to the CEN/CENELEC Internal Regulations, the national standards organizations of the following countries are bound to implement this European Standard: Austria, Belgium, Bulgaria, Croatia, Cyprus, Czech Republic, Denmark, Estonia, Finland, France, Germany, Greece, Hungary, Iceland, Ireland, Italy, Latvia, Lithuania, Luxembourg, Malta, Netherlands, Norway, Poland, Portugal, Romania, Slovakia, Slovenia, Spain, Sweden, Switzerland, Turkey and the United Kingdom.

Endorsement notice

The text of ISO 3745:2012 has been approved by CEN as a EN ISO 3745:2012 without any modification.

Annex ZA (informative)

Relationship between this European Standard and the Essential Requirements of EU Directive 2006/42/EC

This European Standard has been prepared under a mandate given to CEN by the European Commission and the European Free Trade Association to provide one means of conforming to Essential Requirements of the New Approach Directive 2006/42/EC, *Machinery directive*.

Once this standard is cited in the Official Journal of the European Union under that Directive and has been implemented as a national standard in at least one Member State, compliance with the normative clauses of this standard confers, within the limits of the scope of this standard, a presumption of conformity with the relevant Essential Requirements of that Directive and associated EFTA regulations.

WARNING — Other requirements and other EU Directives may be applicable to the products falling within the scope of this standard.

Contents

Page

Foreword	v
Introduction	vi
1 Scope	1
1.1 General	1
1.2 Types of noise and noise sources	1
1.3 Test room	1
1.4 Measurement uncertainty	1
2 Normative references	1
3 Terms and definitions	2
4 Reference meteorological conditions	7
5 Test rooms	8
5.1 Acoustic criterion for adequacy of the test room	8
5.2 Criteria for background noise	8
5.3 Criterion for air temperature	9
6 Instrumentation	9
6.1 Instruments for acoustical measurements	9
6.2 Instruments for meteorological measurements	11
7 Definition, location, installation and operation of noise source under test	11
7.1 General	11
7.2 Auxiliary equipment	11
7.3 Noise source location	11
7.4 Mounting of the noise source	12
7.5 Operation of source during test	12
8 Measurement surface	13
8.1 Spherical measurement surface for use in an anechoic room	13
8.2 Hemispherical measurement surface for use in a hemi-anechoic room	13
9 Determination of sound power levels and sound energy levels	14
9.1 Measurements in the test room	14
9.2 Measurement of meteorological conditions	14
9.3 Microphone positions	14
9.4 Determination of sound power levels of a noise source which emits steady or non-steady noise	16
9.5 Determination of sound energy levels for a noise source which emits impulsive noise	20
9.6 Calculation of directivity indices	22
9.7 Calculation of surface sound pressure level non-uniformity index	23
9.8 Frequency-weighted sound power level and sound energy level	23
10 Measurement uncertainty	23
10.1 Methodology	23
10.2 Determination of σ_{omc}	24
10.3 Determination of σ_{R0}	24
10.4 Typical upper bound values of σ_{R0}	25
10.5 Total standard deviation, σ_{tot} and expanded measurement uncertainty, U	26
11 Information to be recorded	27
11.1 General	27
11.2 Noise source under test	27
11.3 Test room	27
11.4 Instrumentation	27
11.5 Acoustical data	27
12 Test report	28

Annex A (normative) General procedures for qualification of anechoic and hemi-anechoic rooms	29
Annex B (normative) Qualification procedure for spaces within test rooms used in the determination of sound power levels and sound energy levels of specific noise sources	36
Annex C (normative) Calculation of A-weighted sound power levels and A-weighted sound energy levels from one-third-octave band levels	38
Annex D (normative) Array of microphone positions on a spherical measurement surface in a free field	40
Annex E (normative) Arrays of microphone positions on a hemispherical measurement surface in a hemi-free field.....	43
Annex F (normative) Coaxial circular paths of microphones on a hemispherical measurement surface in a hemi-free field.....	48
Annex G (normative) Meridional paths of microphones on a hemispherical measurement surface in a hemi-free field.....	49
Annex H (normative) Spiral paths of microphones on a hemispherical measurement surface in a hemi-free field	51
Annex I (informative) Guidance on the development of information on measurement uncertainty.....	52
Bibliography	62

Foreword

ISO (the International Organization for Standardization) is a worldwide federation of national standards bodies (ISO member bodies). The work of preparing International Standards is normally carried out through ISO technical committees. Each member body interested in a subject for which a technical committee has been established has the right to be represented on that committee. International organizations, governmental and non-governmental, in liaison with ISO, also take part in the work. ISO collaborates closely with the International Electrotechnical Commission (IEC) on all matters of electrotechnical standardization.

International Standards are drafted in accordance with the rules given in the ISO/IEC Directives, Part 2.

The main task of technical committees is to prepare International Standards. Draft International Standards adopted by the technical committees are circulated to the member bodies for voting. Publication as an International Standard requires approval by at least 75 % of the member bodies casting a vote.

Attention is drawn to the possibility that some of the elements of this document may be the subject of patent rights. ISO shall not be held responsible for identifying any or all such patent rights.

ISO 3745 was prepared by Technical Committee ISO/TC 43, *Acoustics*, Subcommittee SC 1, *Noise*.

This third edition cancels and replaces the second edition (ISO 3745:2003), which has been technically revised.

Introduction

This International Standard is one of the series ISO 3741^[3] to ISO 3747^[8], which specify various methods for determining the sound power levels and sound energy levels of noise sources including machinery, equipment and their sub-assemblies. The selection of one of the methods from the series for use in a particular application depends on the purpose of the test to determine the sound power level or sound energy level and on the facilities available. General guidelines to assist in the selection are provided in ISO 3740^[2]. ISO 3741^[3] to ISO 3747^[8] give only general principles regarding the operating and mounting conditions of the machinery or equipment for the purposes of the test. It is important that test codes be established for individual kinds of noise source, in order to give detailed requirements on mounting, loading and operating conditions under which the sound power levels or sound energy levels are to be obtained and to select the appropriate measurement surface and microphone array from among those specified in this International Standard.

The methods given in this International Standard require the source to be mounted in either an anechoic room or a hemi-anechoic room having specified acoustical characteristics. The methods are then based on the premise that the sound power or sound energy of the source is directly proportional to the mean-square sound pressure over a hypothetical measurement surface enclosing the source and otherwise depends on the physical constants of air.

The methods specified in this International Standard permit the determination of the sound power level and the sound energy level in frequency bands and/or with frequency A-weighting applied.

The methods give a precision grade of accuracy (grade 1) as defined in ISO 12001. The resulting sound power levels and sound energy levels include corrections to allow for any differences that might exist between the meteorological conditions under which the tests are conducted and reference meteorological conditions. For applications where there are large uncertainties due to operating conditions or where reduced accuracy is acceptable, reference can be made to the more practical methods of ISO 3744^[6] or ISO 3746^[7]. Guidance on evaluation of measurement uncertainty is given in Annex I.

Acoustics — Determination of sound power levels and sound energy levels of noise sources using sound pressure — Precision methods for anechoic rooms and hemi-anechoic rooms

1 Scope

1.1 General

This International Standard specifies methods for measuring the sound pressure levels on a measurement surface enveloping a noise source (machinery or equipment) in an anechoic room or a hemi-anechoic room. The sound power level (or, in the case of impulsive or transient noise emission, the sound energy level) produced by the noise source, in frequency bands of width one-third octave or with frequency weighting A applied, is calculated using those measurements, including corrections to allow for any differences between the meteorological conditions at the time and place of the test and those corresponding to a reference characteristic acoustic impedance.

In general, the frequency range of interest includes the one-third-octave bands with mid-band frequencies from 100 Hz to 10 000 Hz. In practice, the range is extended or restricted to frequencies beyond or within these limits, to those between which the test room is qualified for the purposes of the measurements.

1.2 Types of noise and noise sources

The methods specified in this International Standard are suitable for all types of noise (steady, non-steady, fluctuating, isolated bursts of sound energy, etc.) defined in ISO 12001.

The noise source under test can be a device, machine, component or sub-assembly. The maximum size of the noise source depends on specified requirements regarding the radius of the hypothetical sphere or hemisphere used as the enveloping measurement surface.

1.3 Test room

The test rooms that are applicable for measurements made in accordance with this International Standard are an anechoic room or hemi-anechoic room, also called, respectively, a free-field test room or hemi-free-field test room.

1.4 Measurement uncertainty

Information is given on the uncertainty of the sound power levels and sound energy levels determined in accordance with this International Standard, for measurements made in limited bands of frequency and with frequency weighting A applied. The uncertainty conforms to ISO 12001:1996, accuracy grade 1 (precision grade).

2 Normative references

The following referenced documents are indispensable for the application of this document. For dated references, only the edition cited applies. For undated references, the latest edition of the referenced document (including any amendments) applies.

ISO 5725 (all parts), *Accuracy (trueness and precision) of measurement methods and results*

ISO 9613-1:1993, *Acoustics — Attenuation of sound during propagation outdoors — Part 1: Calculation of the absorption of sound by the atmosphere*

ISO 12001:1996, *Acoustics — Noise emitted by machinery and equipment — Rules for the drafting and presentation of a noise test code*

ISO/IEC Guide 98-3, *Uncertainty in measurement — Part 3: Guide to the expression of uncertainty in measurement (GUM:1995)*

IEC 60942:2003, *Electroacoustics — Sound calibrators*

IEC 61183, *Electroacoustics — Random-incidence and diffuse-field calibration of sound level meters*

IEC 61260:1995 + AM1:2001, *Electroacoustics — Octave-band and fractional-octave-band filters*

IEC 61672-1:2002, *Electroacoustics — Sound level meters — Part 1: Specifications*

3 Terms and definitions

For the purposes of this document, the following terms and definitions apply.

3.1 sound pressure

p
difference between instantaneous pressure and static pressure

NOTE 1 Adapted from ISO 80000-8:2007^[22], 8-9.2.

NOTE 2 Sound pressure is expressed in pascals.

3.2 sound pressure level

L_p
ten times the logarithm to the base 10 of the ratio of the square of the sound pressure, p , to the square of a reference value, p_0 , expressed in decibels

$$L_p = 10 \lg \frac{p^2}{p_0^2} \text{ dB} \quad (1)$$

where the reference value, p_0 , is 20 μPa

[ISO/TR 25417:2007^[20], 2.2]

NOTE 1 If specific frequency and time weightings as specified in IEC 61672-1 and/or specific frequency bands are applied, this should be indicated by appropriate subscripts; e.g. L_{pA} denotes the A-weighted sound pressure level.

NOTE 2 This definition is technically in accordance with ISO 80000-8:2007^[22], 8-22.

3.3 time-averaged sound pressure level

$L_{p,T}$
ten times the logarithm to the base 10 of the ratio of the time average of the square of the sound pressure, p , during a stated time interval of duration, T (starting at t_1 and ending at t_2), to the square of a reference value, p_0 , expressed in decibels

$$L_{p,T} = 10 \lg \left[\frac{\frac{1}{T} \int_{t_1}^{t_2} p^2(t) dt}{p_0^2} \right] \text{ dB} \quad (2)$$

where the reference value, p_0 , is 20 μPa

NOTE 1 In general, the subscript “ T ” is omitted since time-averaged sound pressure levels are necessarily determined over a certain measurement time interval.

NOTE 2 Time-averaged sound pressure levels are often A-weighted, in which case they are denoted by $L_{pA,T}$, which is usually abbreviated to L_{pA} .

NOTE 3 Adapted from ISO/TR 25417:2007^[20], 2.3.

3.4 single event time-integrated sound pressure level

L_E

ten times the logarithm to the base 10 of the ratio of the integral of the square of the sound pressure, p , of an isolated single sound event (burst of sound or transient sound) over a stated time interval T (starting at t_1 and ending at t_2) to a reference value, E_0 , expressed in decibels

$$L_E = 10 \lg \left[\frac{\int_{t_1}^{t_2} p^2(t) dt}{E_0} \right] \text{ dB} \quad (3)$$

where the reference value, E_0 , is $(20 \mu\text{Pa})^2 \text{ s} = 4 \times 10^{-10} \text{ Pa}^2 \text{ s}$

[ISO 3741:2010^[3], 3.4]

NOTE 1 This quantity can be obtained by $L_{p,T} + 10 \lg(T/T_0)$ dB, where $T_0 = 1$ s.

NOTE 2 When used to measure sound immission (see ISO 11690-1^[19]), this quantity is usually called “sound exposure level” (see ISO/TR 25417:2007^[20], 2.7).

3.5 measurement time interval

T

portion or a multiple of an operational period or operational cycle of the noise source under test for which the time-averaged sound pressure level is determined

NOTE Measurement time interval is expressed in seconds.

[ISO 3741:2010^[3], 3.5]

3.6 free sound field

sound field in a homogeneous, isotropic medium free of boundaries

NOTE In practice, a free sound field is a field in which the influence of reflections at the boundaries or other disturbing objects is negligible over the frequency range of interest.

[ISO/TR 25417:2007^[20], 2.17]

3.7 anechoic room anechoic test room free-field test room

test room in which a free sound field is obtained

3.8 free sound field over a reflecting plane

free sound field in the half-space above an infinite reflecting plane in the absence of any other obstacles

3.9 reflecting plane

sound reflecting planar surface on which the noise source under test is located

3.10

hemi-anechoic room
hemi-anechoic test room
hemi-free-field test room

test room in which a free sound field over a reflecting plane is obtained

3.11

frequency range of interest

for general purposes, the frequency range of one-third-octave bands with nominal mid-band frequencies from 100 Hz to 10 000 Hz

NOTE For special purposes, the frequency range may be extended or reduced, provided that the test environment and instrument specifications are satisfactory for use over the modified frequency range. Changes to the frequency range of interest should be made clear in the test report. For sources in which the A-weighted sound power levels are determined by sound at predominantly high or low frequencies, the frequency range of interest should be extended to include these frequencies.

3.12

measurement radius

r

radius of a spherical or hemispherical measurement surface

NOTE Measurement radius is expressed in metres.

3.13

measurement surface

hypothetical surface of area, S , on which the microphone positions are located at which the sound pressure levels are measured, enveloping the noise source under test and, in the case of a hemi-anechoic room, terminating on the reflecting plane on which the source is located

NOTE The measurement surface area is expressed in metres squared.

3.14

characteristic source dimension

d_0

distance from the origin of the co-ordinate system to the farthest corner of the reference box, where the reference box is defined as a hypothetical rectangular parallelepiped that just encloses the source including all the significant sound radiating components and any test table on which the source may be mounted; in the case of a hemi-anechoic room the reference box terminates on the reflecting plane

NOTE 1 Characteristic source dimension is expressed in metres.

NOTE 2 For illustration see Figure 1.

3.15

background noise

noise from all sources other than the noise source under test

NOTE Background noise includes contributions from airborne sound, noise from structure-borne vibration, and electrical noise in the instrumentation.

3.16

background noise correction

K_1

correction applied to each of the measured sound pressure levels on the measurement surface to account for the influence of background noise

NOTE 1 Background noise correction is expressed in decibels.

NOTE 2 The background noise correction is frequency dependent; the correction in the case of a frequency band is denoted K_{1f} , where f denotes the relevant mid-band frequency; in the case of A-weighting, the quantity is denoted K_{1A} .

3.17
surface time-averaged sound pressure level

\overline{L}_p

mean (energy average) of the time-averaged sound pressure levels at all the microphone positions, or traverses, on the measurement surface, with the background noise corrections, K_1 , applied at each microphone position or traverse

$$\overline{L}_p = 10 \lg \left[\frac{\sum_{i=1}^{N_M} 10^{0,1L_{pi}(\text{ST})}}{N_M} \right] \text{dB} \quad (4)$$

where

$L_{pi}(\text{ST})$ is the background noise corrected time-averaged sound pressure level for the i th microphone position or traverse on the measurement surface, with the noise source under test in operation, in decibels;

N_M is the number of microphone positions or traverses.

NOTE Surface time-averaged sound pressure level is expressed in decibels.

3.18
surface single event time-integrated sound pressure level

\overline{L}_E

mean (energy average) of the single event time-integrated sound pressure levels at all the microphone positions on the measurement surface, with the background noise correction, K_1 , applied at each microphone position

$$\overline{L}_E = 10 \lg \left[\frac{\sum_{i=1}^{N_M} 10^{0,1L_{Ei}(\text{ST})}}{N_M} \right] \text{dB} \quad (5)$$

where

$L_{Ei}(\text{ST})$ is the background noise corrected single event time-integrated sound pressure level for the i th microphone position on the measurement surface, with the noise source under test in operation, in decibels;

N_M is the number of microphone positions.

NOTE Surface single event time-integrated sound pressure level is expressed in decibels.

3.19
sound power

P

through a surface, product of the sound pressure, p , and the component of the particle velocity, u_n , at a point on the surface in the direction normal to the surface, integrated over that surface

[ISO 80000-8:2007^[22], 8-16 reproduced in ISO/TR 25417:2007^[20], 2.8]

NOTE 1 Sound power is expressed in watts.

NOTE 2 The quantity relates to the rate per time at which airborne sound energy is radiated by a source.

3.20 sound power level

L_W
ten times the logarithm to the base 10 of the ratio of the sound power of a source, P , to a reference value, P_0 , expressed in decibels

$$L_W = 10 \lg \frac{P}{P_0} \text{ dB} \quad (6)$$

where the reference value, P_0 , is 1 pW

NOTE 1 If a specific frequency weighting as specified in IEC 61672-1 and/or specific frequency bands are applied, this should be indicated by appropriate subscripts; e.g. $L_{W,A}$ denotes the A-weighted sound power level.

NOTE 2 This definition is technically in accordance with ISO 80000-8:2007^[22], 8-23.

[ISO/TR 25417:2007^[20], 2.9]

3.21 sound energy

J
integral of the sound power, P , over a stated time interval of duration T (starting at t_1 and ending at t_2)

$$J = \int_{t_1}^{t_2} P(t) \text{ dt} \quad (7)$$

NOTE 1 Sound energy is expressed in joules.

NOTE 2 The quantity is particularly relevant for non-stationary, intermittent sound events.

[ISO/TR 25417:2007^[20], 2.10]

3.22 sound energy level

L_J
ten times the logarithm to the base 10 of the ratio of the sound energy, J , to a reference value, J_0 , expressed in decibels

$$L_J = 10 \lg \frac{J}{J_0} \text{ dB} \quad (8)$$

where the reference value, J_0 , is 1 pJ

NOTE If a specific frequency weighting as specified in IEC 61672-1 and/or specific frequency bands are applied, this should be indicated by appropriate subscripts; e.g. $L_{J,A}$ denotes the A-weighted sound energy level.

[ISO/TR 25417:2007^[20], 2.11]

3.23 directivity index

D_{li}

measure of the extent to which a noise source under test radiates sound in the direction of the i th microphone position on a measurement surface, relative to the mean sound radiation over the measurement surface

$$D_{li} = L_{pi} - \overline{L_p} \quad (9)$$

where

L_{pi} is the background noise corrected sound pressure level (either time-averaged or single event time-integrated) for the i th microphone position on the measurement surface, with the noise source under test in operation, in decibels;

$\overline{L_p}$ is the surface sound pressure level (either time-averaged or single event time-integrated), in decibels.

3.24 surface sound pressure level non-uniformity index

V_1

measure of the variability of measured sound pressure levels over the measurement surface

$$V_1 = \sqrt{\frac{1}{(N_M - 1)} \sum_{i=1}^{N_M} (L_{pi} - L_{pav})^2} \quad (10)$$

where

L_{pi} is the background noise corrected sound pressure level (either time-averaged or single event time-integrated) for the i th microphone position on the measurement surface with the noise source under test in operation, in decibels;

L_{pav} is the arithmetic average of the background noise corrected sound pressure levels (either time-averaged or single event time-integrated) over all the microphone positions on the measurement surface for the noise source under test, in decibels;

N_M is the number of microphone positions.

NOTE When V_1 is determined at a particular measurement radius, the quantity is denoted V_{1r} .

4 Reference meteorological conditions

Reference meteorological conditions for the purpose of calculating the sound power level and sound energy level, corresponding to a reference characteristic acoustic impedance of air $\rho c = 411,5 \text{ N s/m}^3$ (where ρ is the density of air and c is the speed of sound) are:

- a) air temperature: 23,0 °C;
- b) static pressure: 101,325 kPa;
- c) relative humidity: 50 %.

5 Test rooms

5.1 Acoustic criterion for adequacy of the test room

Anechoic or hemi-anechoic rooms that are applicable for measurements in accordance with this International Standard either satisfy:

- a) Annex A over the frequency range of interest, for use in general purpose measurements; or
- b) Annex B over the frequency range of interest, for determination of sound power levels of a specific noise source.

Annex A and Annex B specify procedures for determining the extent of deviations of the test room from the ideal free-field condition or the ideal hemi-free-field condition, and criteria are given to assess the adequacy of the test room. Qualification procedures for the test room shall be in accordance with Annex A or Annex B.

For sources in which the A-weighted sound levels are determined by sound at predominantly high or low frequencies, outside the nominal frequency range of interest (see 3.11), the frequency range of interest shall be extended to include these frequencies, and this shall be clearly stated in the test report.

NOTE If it is necessary to make measurements in test rooms or spaces within test rooms where the requirements of Annex A or Annex B are exceeded, see ISO 3744^[6], ISO 3746^[7], ISO 9614-1^[15] or ISO 9614-2^[16].

5.2 Criteria for background noise

5.2.1 Relative criteria

5.2.1.1 General

The difference between the level of the background noise and that of the noise source under test (when measured in the presence of this background noise) averaged (see 9.4.3) over all microphone positions or traverses, shall be at least 6 dB for all frequency bands, and for one-third-octave bands of mid-band frequency from 250 Hz to 5 000 Hz shall be at least 10 dB. If this requirement is met, the background noise criteria of this International Standard are satisfied.

NOTE 1 The same criteria are applied to single event levels, where the measurement time interval used to measure the background noise is the same as the measurement time interval associated with the measurement of the single event.

NOTE 2 The noise associated with the microphone traversing mechanism, if one is used for the measurements, is considered to be part of the background noise. In such cases, the background noise should be measured with the traversing mechanism operating.

5.2.1.2 Frequency band measurements

The requirements of 5.2.1.1 may not be achievable in all frequency bands, even when the background noise levels in the test room are extremely low and well controlled. Therefore, for the purposes of determining compliance with the background noise criteria given in 5.2.1.1, any band may be excluded from the frequency range of interest if the A-weighted sound power level (see Annex C) of that band (after correcting for background noise) is at least 15 dB below the highest A-weighted sound power level in any frequency band.

5.2.1.3 A-weighted measurements

If the A-weighted sound power level or sound energy level is to be determined from frequency band levels and reported, the following steps shall be followed to determine whether this quantity meets the background noise criteria of this International Standard:

- a) the A-weighted sound power level or sound energy level is computed in accordance with the procedures in this International Standard using the data from every frequency band within the frequency range of interest;

- b) the computation is repeated, but excluding those bands for which $\Delta L_p < 6$ dB for one-third-octave bands of mid-band frequency 200 Hz and below and 6 300 Hz and above, and for which $\Delta L_p < 10$ dB for one-third-octave bands of mid-band frequency from 250 Hz to 5 000 Hz.

If the difference between these two levels is less than 0,5 dB, the A-weighted sound power level or sound energy level determined from the data for all bands shall be considered as conforming to the background noise criteria of this International Standard.

5.2.2 Absolute criteria

If it can be demonstrated that the background noise levels in the test room at the time of the measurements are less than or equal to those given in Table 1 for all bands within the frequency range of interest, the measurements can be taken as having met the background noise requirements of this International Standard, even if the 6 dB and 10 dB requirements (see 5.2.1.1) are not met for all bands. It can be assumed that the source emits little or no measurable noise in these frequency bands, and that the data reported represent an upper bound to the sound power level or sound energy level in these bands.

If levels of noise measured at the smallest possible distance from the source (see Clause 8) are less than or equal to those given in Table 1, the frequency range of interest may be restricted to a contiguous range of frequencies that includes both the lowest and highest frequencies at which the sound pressure level from the noise source exceeds the corresponding value in Table 1. In such cases, the applicable frequency range of interest shall be reported.

NOTE The absolute background criteria are intended for general sound power measurements; they exceed the threshold of audibility and may not be suitable for all uses.

5.2.3 Statement of non-conformity with criteria

If the above background noise criteria are not satisfied, the report shall clearly state that the background noise requirements of this International Standard have not been met, and, in the case of frequency band measurements, shall identify the particular frequency bands that do not meet the criteria. Furthermore, the report shall not state or imply that the measurements have been made “in full conformity” with ISO 3745.

5.3 Criterion for air temperature

The air temperature in the test room shall be within the range 15 °C to 30 °C.

NOTE The equations in Clause 9 used for the calculation of the sound power level and the sound energy level include a multiplication factor which is an approximation to cover a variety of possible sound-generating mechanisms (monopole, dipole, quadrupole, etc.) which pertain to different kinds of noise source; the range of air temperature is limited in order to guarantee a deviation smaller than 0,2 dB in the result.

6 Instrumentation

6.1 Instruments for acoustical measurements

6.1.1 General

The instruments for measuring sound pressure levels, including microphone(s) as well as cable(s), windscreen(s), recording devices and other accessories, if used, shall meet the requirements of IEC 61672-1:2002, class 1. Filters shall meet the requirements of IEC 61260:1995, class 1.

The microphone shall be oriented so that the reference direction of the microphone (as specified in IEC 61672-1) is normal to the measurement surface.

6.1.2 Calibration

At the beginning and the end of every measurement session and at least at the beginning and the end of each measurement day, the entire sound pressure level measuring system shall be checked at one or more

frequencies by means of a sound calibrator meeting the requirements of IEC 60942:2003, class 1. Without any further adjustment, the difference between the readings of two consecutive checks shall be less or equal to 0,3 dB. If this value is exceeded, the results of measurements obtained after the previous satisfactory check shall be discarded.

Table 1 — Maximum background noise levels in test room for absolute criteria

One-third-octave mid-band frequency	Maximum band sound pressure level
Hz	dB
50	44
63	38
80	32
100	27
125	22
160	16
200	13
250	11
315	9
400	8
500	7
630	7
800	7
1 000	7
1 250	7
1 600	7
2 000	7
2 500	8
3 150	8
4 000	8
5 000	8
6 300	8
8 000	12
10 000	14
12 500	11
16 000	46
20 000	46

6.1.3 Verification

Compliance of the sound pressure level measuring instrument, the filters and the sound calibrator with the relevant requirements shall be verified by the existence of a valid certificate of compliance. If applicable, random incidence response of the microphone shall be verified by a procedure from IEC 61183. All compliance testing shall be conducted by a laboratory being accredited or otherwise nationally authorized to perform the relevant tests and calibrations and ensuring metrological traceability to the appropriate measurement standards.

Unless national regulations dictate otherwise, it is recommended that the sound calibrator should be calibrated at intervals not exceeding 1 year, the compliance of the instrumentation system with the requirements of IEC 61672-1 should be verified at intervals not exceeding 2 years, and the compliance of the filter set with the requirements of IEC 61260 should be verified at intervals not exceeding 2 years.

6.2 Instruments for meteorological measurements

6.2.1 General

The maximum permissible error for instruments used for meteorological measurements shall be

- a) ± 1 K for temperature measuring devices;
- b) ± 10 % for relative humidity measuring devices;
- c) ± 2 kPa for static pressure measuring devices.

NOTE It is not necessary to specify values for these uncertainties if their influence on the final measured value is determined to be within acceptable limits using ISO/IEC Guide 98-3.

6.2.2 Verification

For instruments used for monitoring meteorological conditions, e.g. to ensure that any of these parameters is within a specified interval, manufacturer's specifications are deemed sufficient to verify these requirements.

If any of the meteorological parameters has a direct influence on the measurement result, the compliance of the measuring instrument with the relevant requirement has to be verified by a valid calibration certificate from a laboratory being accredited or otherwise nationally authorized to perform the relevant calibration and ensuring metrological traceability to the appropriate measurement standards.

7 Definition, location, installation and operation of noise source under test

7.1 General

The manner in which the noise source under test is installed and operated may have a significant influence on the sound power or sound energy emitted by a noise source. This clause specifies conditions that are intended to minimize variations in the noise emission due to the installation and operating conditions of the noise source under test. Relevant instructions of a noise test code, if any exists for the family of machinery or equipment to which the noise source under test belongs, shall be followed. The same installation, mounting and operating conditions of the noise source under test shall be used for the determination of emission sound pressure levels and sound power levels.

Particularly for large machines, it is necessary to decide which components, sub-assemblies, auxiliary equipment, power sources; etc., belong to the noise source under test.

7.2 Auxiliary equipment

Care shall be taken to ensure that any electrical conduits, piping or air ducts connected to the noise source under test do not radiate significant amounts of sound energy into the test environment.

If possible, all auxiliary equipment necessary for the operation of the noise source under test that is not a part of it shall be located outside the test room. If this is impractical, care shall be taken to minimize any sound radiated into the test environment from such equipment. The noise source under test shall be taken to include all significant sources of sound emission, including auxiliary equipment which cannot either be removed or adequately quietened.

7.3 Noise source location

In locating the source within the test room, it is important to allow sufficient space around the source so that the measurement surface can envelop it in accordance with the requirements of Clause 8.

Detailed information on installation conditions shall be based upon the general requirements of this International Standard and particular requirements of the relevant noise test code, if one exists.

7.4 Mounting of the noise source

7.4.1 General

In many cases, the sound power or sound energy emitted by a noise source under test depends upon the support or mounting conditions of the noise source. Whenever a typical mounting condition exists for a noise source, that condition shall be used or simulated, if practicable.

Mounting conditions specified or recommended by the manufacturer of the noise source under test shall be used unless otherwise specified in any relevant noise test code. If a typical mounting condition does not exist, cannot be utilized for the test or if there are several alternative possibilities, care shall be taken to ensure that the mounting arrangement does not induce a variability in the sound output of the source which is atypical. Precautions shall be taken to reduce any sound radiation from the structure on which the noise source is mounted.

Many small noise sources, although themselves poor radiators of low-frequency sound, can, as a result of the method of mounting, radiate more low-frequency sound when their vibrational energy is transmitted to surfaces large enough to be efficient radiators. Resilient mounting shall be interposed, if possible, between the noise source to be tested and the supporting surfaces, so that the transmission of vibration to the support and the reaction of the source are both minimized. In this case, the mounting base should be rigid (i.e. have a sufficiently high mechanical impedance) to prevent it from vibrating excessively and radiating sound. However, resilient mounts shall be used only if the noise source under test is resiliently mounted in typical field installations.

Coupling conditions, e.g. between prime movers and driven machines, can exert a considerable influence on the sound radiation of the noise source under test.

7.4.2 Hand-held machinery and equipment

Such machinery and equipment shall be suspended or guided by hand, so that no structure-borne sound is transmitted via any attachment that does not belong to the noise source under test. If the noise source under test requires a support for its operation during testing, the support structure shall be small, considered to be a part of the noise source under test, and comply with the requirements of the relevant noise test code, if any exists.

7.4.3 Base-mounted, wall-mounted and table-top machinery and equipment

Such machinery and equipment shall be placed on a reflecting (acoustically hard) plane (floor or wall). Base-mounted machinery or equipment intended exclusively for mounting in front of a wall shall be installed on an acoustically hard surface in front of an acoustically hard wall. Table-top machinery or equipment shall be placed on the floor at least 1,5 m from any wall of the room, unless a table or stand is required for operation in accordance with the noise test code for the machinery or equipment under test. The table or stand shall be at least 1,5 m from any absorptive surface of the test room. Such machinery or equipment shall be placed at the centre of the top of a standard test table.

NOTE An example of a test table is given in ISO 11201^[18].

7.5 Operation of source during test

The sound power or sound energy emitted by a source, whether stationary or moving, can be affected by the load applied, the running speed, and the conditions under which it is operating. The source shall be tested, wherever possible, under conditions that are reproducible and representative of the noisiest operation in typical usage. The specifications given in a noise test code, if any exists, shall be followed, but in the absence of a noise test code one or more of the following modes of operation shall be selected for the test(s):

- a) source under specified load and conditions;
- b) source under full load [if different from a)];
- c) source under no load (idling);
- d) source at maximum operating speed under defined conditions;

- e) source operating under conditions corresponding to maximum sound generation representative of normal use;
- f) source with simulated loading, under defined conditions;
- g) source undergoing a characteristic work cycle under defined conditions.

The source shall be stabilized in the desired operating condition, with any power source or transmission system running at a stable temperature, prior to the start of measurements for sound power level or sound energy level determination. The load, speed and operating conditions shall either be held constant during the test or varied through a defined cycle in a controlled manner.

If the sound power or sound energy emission depends on secondary operating parameters, e.g. the type of material being processed, the design of cutting tool or the humidity, those parameters shall be selected, as far as is practicable, that give the smallest variations and that are typical of normal use. If simulated loading conditions are used, they shall be chosen such that the sound power levels or sound energy levels of the source under test are representative of normal use.

8 Measurement surface

8.1 Spherical measurement surface for use in an anechoic room

The spherical measurement surface shall be centred on the acoustic centre of the noise source under test, either the actual acoustic centre if known or an assumed acoustic centre such as the geometric centre of the source. The measurement radius, r , shall satisfy all of the following conditions:

- a) $r \geq 2d_0$, where d_0 is the characteristic dimension of the noise source under test (see 3.14 and Figure 1);
- b) $r \geq \lambda/4$, where λ is the wavelength of sound at the lowest frequency of interest;
- c) $r \geq 1$ m.

The measurement surface shall be wholly contained within the region of the anechoic room which is qualified for measurements in accordance with Annex A or Annex B.

For small, low-noise sources to be measured over a limited range of frequencies, the measurement radius may be less than 1 m, but not less than 0,5 m. However, conditions a) and b) are relevant and a radius less than 1 m could itself impose limits on the frequency range over which tests are performed.

The area of a spherical measurement surface, $S_1 = 4\pi r^2$ (see 9.4.4.1 and 9.5.3.1).

8.2 Hemispherical measurement surface for use in a hemi-anechoic room

The hemispherical measurement surface shall be centred on a point on the floor of the test room vertically beneath the assumed acoustic centre of the noise source under test, either the actual acoustic centre if known or the geometric centre if the acoustic centre is unknown. The measurement radius, r , shall satisfy all of the following conditions:

- a) $r \geq 2d_0$ or $r \geq 3h_0$, whichever is the larger, where d_0 is the characteristic dimension of the noise source under test (see 3.14 and Figure 1), and h_0 is the distance from the acoustic centre of the source to the floor;
- b) $r \geq \lambda/4$, where λ is the wavelength of sound at the lowest frequency of interest;
- c) $r \geq 1$ m.

The measurement surface shall be wholly contained within the region of the hemi-anechoic room which is qualified for measurements in accordance with Annex A or Annex B.

For small, low-noise sources to be measured over a limited range of frequencies, the measurement radius may be less than 1 m, but not less than 0,5 m. However, conditions a) and b) are relevant and a radius less than 1 m could itself impose limits on the frequency range over which tests are performed.

The area of a hemispherical measurement surface, $S_2 = 2\pi r^2$ (see 9.4.4.2 and 9.5.3.2).

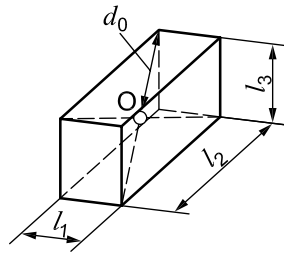

a) **Anechoic room**, $d_0 = \sqrt{(l_1/2)^2 + (l_2/2)^2 + (l_3/2)^2}$

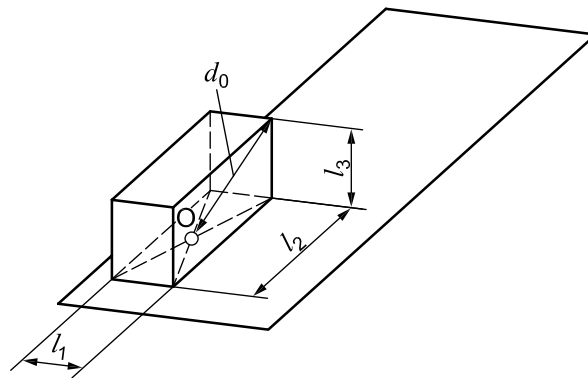

b) **Hemi-anechoic room**, $d_0 = \sqrt{(l_1/2)^2 + (l_2/2)^2 + l_3^2}$

Figure 1 — Reference box, centre for the measurement surface (when using the geometric centre of the source) and characteristic source dimensions for application in an anechoic and a hemi-anechoic room

9 Determination of sound power levels and sound energy levels

9.1 Measurements in the test room

Procedures are specified for measurements in both an anechoic room and a hemi-anechoic room. In both kinds of test rooms, the procedures are applicable provided that the rooms are qualified in accordance with either Annex A or Annex B (see 5.1).

For sources in which the A-weighted sound levels are determined by sound at predominantly high or low frequencies outside the frequency range of interest (see 3.11), the frequency range of interest shall be extended to include these frequencies in the calculation of L_{WA} or L_{JA} , and this shall be made clear in the test report.

9.2 Measurement of meteorological conditions

The meteorological conditions (air temperature, static pressure and relative humidity) around the noise source at the time of the test shall be measured.

9.3 Microphone positions

9.3.1 General

Environmental conditions can have an adverse effect on microphones used for the measurements. The effect of such conditions (e.g. strong electric or magnetic fields, wind impingement of air discharge, if any, from

the noise source under test) shall be avoided by proper selection or placement of the microphones. The attenuation of the air at frequencies above 10 000 Hz (if measurements are made at these frequencies) shall be compensated in accordance with ISO 9613-1.

To obtain the sound pressure levels on the spherical or hemispherical measurement surface, one of the following four arrangements or a user-defined arrangement that meets the requirements of 9.3.7 shall be used:

- a) an array of fixed microphone positions, the positions being distributed over the measurement surface, see 9.3.2 and 9.3.3;

NOTE It is possible either to move a single microphone from one position to the next sequentially or to use a number of fixed microphones and to sample their outputs sequentially or simultaneously.

- b) a single microphone moved along multiple circular paths regularly spaced on the measurement surface (or a microphone held fixed while the noise source under test is rotated through 360° or multiples thereof) see 9.3.4;
- c) a single microphone moved along multiple meridional arcs regularly spaced on the measurement surface, see 9.3.5;
- d) a single microphone moved along a spiral path around the vertical axis of the measurement surface, see 9.3.6.

9.3.2 Fixed positions for measurements on a spherical measurement surface in an anechoic room

The array of 20 microphone positions shown in Annex D numbered from 1 to 20 shall be used. In general, the number of microphone positions is sufficient if the difference, in decibels, between the highest and lowest sound pressure levels measured in all frequency bands of interest is numerically less than half the number of microphone positions. Frequency bands excluded in 5.2.1 are exempt from this requirement. If this requirement is not satisfied using points 1 to 20 from Annex D, an additional 20 point array shown in Annex D numbered from 21 to 40 shall be used. The 20 positions and the 40 positions on the two arrays are associated with equal areas on the surface of the sphere of Annex D.

If the requirement on the sufficiency of the number of microphone positions is not satisfied by the 40 positions on the two arrays, a detailed investigation is necessary of the sound pressure levels over a restricted area of the sphere where “beaming” from a highly directional source is observed. This detailed investigation is necessary to determine the highest and lowest values of the sound pressure level in the frequency band of interest. If this procedure is followed, the microphone positions are not usually associated with equal areas on the measurement surface and proper allowance shall be made (see 9.4.3.2).

9.3.3 Fixed positions for measurements on a hemispherical measurement surface in a hemi-anechoic room

The array of 20 microphone positions shown in Annex E numbered from 1 to 20 shall be used. In general, the number of microphone positions is sufficient if the difference in decibels between the highest and lowest sound pressure levels measured in all frequency bands of interest is numerically less than half the number of microphone positions. Frequency bands excluded in 5.2.1 are exempt from this requirement. If this requirement is not satisfied using points 1 to 20 from Annex E, an additional 20 point array shown in Annex E numbered from 21 to 40 shall be used. The 20 positions and the 40 positions on the two arrays are associated with equal areas on the surface of the hemisphere of Annex E.

If the requirement on the sufficiency of the number of microphone positions is not satisfied by the 40 positions on the two arrays, a detailed investigation is necessary of the sound pressure levels over a restricted area of the hemisphere where “beaming” from a highly directional source is observed. This detailed investigation is necessary to determine the highest and lowest values of the sound pressure level in the frequency band of interest. If this procedure is followed, the microphone positions are not usually associated with equal areas on the measurement surface and proper allowance shall be made (see 9.4.3.2).

9.3.4 Coaxial circular paths in parallel planes on a sphere or hemisphere (for measurements in a hemi-anechoic room)

The sound pressure level shall be averaged in space and time by moving microphones along at least 10 circular paths as shown in Annex F, with heights corresponding to those specified for the upper half-space in Table D.1. For noise sources which emit sound at discrete frequencies, and preferably for other noise sources as well, the sound pressure level shall be averaged by moving the microphones along at least 20 circular paths with heights specified in Table E.1.

The circular paths may be achieved by uniformly rotating either the microphone or the noise source slowly through 360°. If a turntable is used to rotate the noise source, its surface shall be at a height of not more than 10 % of the height of the noise source from the reflecting plane and shall preferably be flush with the reflecting plane. The coaxial circular paths may be measured simultaneously or successively using one or more microphones.

9.3.5 Meridional arc traverses on a sphere or hemisphere

A single microphone shall be traversed along a semi-circular arc about a horizontal axis through the centre of the noise source, see Figure G.1. The vertical velocity (dz/dt) shall be held constant, i.e. the angular velocity of the microphone support is accelerated to be proportional to $1/\cos \gamma$, where γ is the angle above the horizontal. The microphone output is squared and averaged by electronic means, giving suitable weight to the surface area of the sphere or hemisphere. Alternatively, a constant angular velocity may be used, but with electronic weighting in accordance with $\cos \gamma$ (see Figure G.1).

At least eight such microphone traverses at equal increments of azimuth angle around the noise source shall be used. This may be accomplished by rotating the noise source.

9.3.6 Spiral path on a sphere or hemisphere

A single microphone shall be traversed along one meridional path as in 9.3.5, and simultaneously through an integral number of at least five circular paths, thus forming a spiral path around the vertical axis of the measurement surface. Alternatively, the spiral path shall be generated by slowly rotating the noise source under test at a constant rotational speed through at least five complete turns while traversing the microphone along a meridional path. An example of a spiral path is shown in Annex H. Angular weighting is described in 9.3.5.

9.3.7 Other microphone arrangements

Other microphone arrangements and measurement surfaces which provide improved accuracy in determination of sound power levels or sound energy levels are not excluded by the above requirements. However, it shall be demonstrated that the deviation between the sound power level or sound energy level in each one-third-octave band of frequency throughout the frequency range of interest and that determined with one of the above arrangements does not exceed $\pm 0,5$ dB.

NOTE An alternative arrangement is defined to improve accuracy and not simply to reduce the number of microphone positions or otherwise compromise one of the specified arrays in 9.3.2 to 9.3.6. An example of an alternative cylindrical measurement surface and microphone arrangement can be found in Reference [23].

9.4 Determination of sound power levels of a noise source which emits steady or non-steady noise

9.4.1 Measurement of sound pressure levels

Time-averaged sound pressure levels from the noise source under test, $L'_{pi(ST)}$ (either in one-third-octave frequency bands or A-weighted), shall be obtained at each microphone position or over each microphone traverse, i ($i = 1, 2 \dots N_M$) over a typical period of operation of the source for each mode of operation selected (see 7.5). Where the sound pressure levels at individual microphone positions vary with time, it is important to select carefully the measurement time interval and the interval chosen shall be stated in the test report. For frequency bands centred on or below 160 Hz, the measurement time interval shall be at least 30 s. For frequency bands centred on or above 200 Hz, the measurement time interval shall be at least 10 s. When using

a traversing microphone, the integrating time shall be an integral number of full traverses and shall include at least two full traverses.

In addition, either immediately before or immediately after the sound pressure levels from the noise source under test are measured, the time-averaged sound pressure levels of the background noise, $L_{pi(B)}$, shall be obtained at each microphone position or with the traversing microphone, over the same measurement time interval as that used for the noise source under test.

9.4.2 Corrections for background noise

The background noise correction, K_{1i} , at the i th microphone position or for the i th microphone traverse in each one-third-octave band shall be calculated using Equation (11):

$$K_{1i} = -10 \lg(1 - 10^{-0,1\Delta L_{pi}}) \text{ dB} \quad (11)$$

where

$$\Delta L_{pi} = L'_{pi(ST)} - L_{pi(B)}$$

in which

$L'_{pi(ST)}$ is the time-averaged one-third-octave-band sound pressure level measured at the i th microphone position or for the i th microphone traverse, with the noise source under test (ST) in operation, in decibels;

$L_{pi(B)}$ is the time-averaged one-third-octave band sound pressure level of the background noise (B) measured at the i th microphone position or for the i th microphone traverse, in decibels.

If $\Delta L_{pi} \geq 15$ dB, K_{1i} is assumed to be zero.

If $6 \text{ dB} \leq \Delta L_{pi} < 15$ dB, for one-third-octave bands of mid-band frequency 200 Hz and below, and 6 300 Hz and above, K_{1i} shall be calculated in accordance with Equation (11).

If $10 \text{ dB} \leq \Delta L_{pi} < 15$ dB, for one-third-octave bands of mid-band frequency 250 Hz to 5 000 Hz, K_{1i} shall be calculated in accordance with Equation (11).

If $\Delta L_{pi} < 6$ dB for one or more one-third-octave bands of mid-band frequency 200 Hz and below and 6 300 Hz and above, K_{1i} shall be set to 1,26 dB (the value for $\Delta L_{pi} = 6$ dB). If $\Delta L_{pi} < 10$ dB for one or more one-third-octave bands of mid-band frequency 250 Hz to 5 000 Hz, K_{1i} shall be set to 0,46 dB (the value for $\Delta L_{pi} = 10$ dB). In either case, it shall be clearly stated in the test report, as well as in graphs and tables of results, that the data in such bands represent upper bounds to the sound power level of the noise source under test.

9.4.3 Calculation of surface time-averaged sound pressure levels

9.4.3.1 Measurement surface with segments having equal areas

For a measurement surface having fixed microphone positions or circular microphone traverses associated with equal segment areas, the surface time-averaged sound pressure level, $\overline{L_p}$, shall be calculated using Equation (12):

$$\overline{L_p} = 10 \lg \left[\frac{1}{N_M} \sum_{i=1}^{N_M} 10^{0,1L_{pi}} \right] \text{ dB} \quad (12)$$

where

$$L_{pi} = L'_{pi(ST)} - K_{1i};$$

N_M is the number of microphone positions.

9.4.3.2 Measurement surface with segments having unequal areas

For a measurement surface having fixed microphone positions or circular microphone traverses associated with unequal segment areas, the surface time-averaged sound pressure level, for the chosen mode of operation of the noise source under test, \overline{L}_p , shall be calculated using Equation (13):

$$\overline{L}_p = 10 \lg \left[\frac{1}{S} \sum_{i=1}^{N_M} S_i \times 10^{0,1 L_{pi}} \right] \text{ dB} \quad (13)$$

where

$$L_{pi} = L'_{pi}(\text{ST}) - K_{1i}$$

S_i is the partial area of the measurement surface associated with the i th microphone position or traverse;

S is the total area of the measurement surface where

$$S = \sum_{i=1}^{N_M} S_i$$

N_M is the number of microphone positions.

9.4.3.3 Surface time-averaged sound pressure levels from measurements using meridional arc traverses or a spiral path

When the microphone moves along a meridional arc traverse or a spiral path (see 9.3.5 and 9.3.6) the surface time-averaged sound pressure level, \overline{L}_p , is obtained by squaring and averaging the output of the microphone and giving suitable weight to the surface areas of the sphere.

9.4.4 Calculation of sound power levels

9.4.4.1 Sound power level in an anechoic room

In a free field, the sound power level in each frequency band of interest or A-weighted, as appropriate, L_W , under reference meteorological conditions shall be calculated using Equation (14):

$$L_W = \overline{L}_p + 10 \lg \left(\frac{S_1}{S_0} \right) \text{ dB} + C_1 + C_2 + C_3 \quad (14)$$

where

\overline{L}_p is the surface time-averaged sound pressure level for the noise source under test, in decibels;

S_1 is the area of the spherical measurement surface, in square metres;

$S_0 = 1 \text{ m}^2$;

C_1 is the reference quantity correction, in decibels, to account for the different reference quantities used to calculate decibel sound pressure level and decibel sound power level, and is a function of the characteristic acoustic impedance of the air under the meteorological conditions at the time and place of the measurements:

$$C_1 = 10 \lg \left[\frac{p_0^2 S_0}{\rho c P_0} \right] \text{ dB}$$

$$= -10 \lg \frac{p_s}{p_{s,0}} \text{ dB} + 5 \lg \left[\frac{(273 + \theta)}{\theta_0} \right] \text{ dB}$$

C_2 is the acoustic radiation impedance correction, in decibels, to change the actual sound power relevant for the meteorological conditions at the time and place of the measurement into the sound power under reference meteorological conditions, the value shall be obtained from the appropriate noise test code, but in the absence of a noise test code, the following equation is valid for a monopole source, and is a mean value for other sources (References [25][27]):

$$C_2 = -10 \lg \frac{p_s}{p_{s,0}} \text{ dB} + 15 \lg \left[\frac{(273 + \theta)}{\theta_1} \right] \text{ dB}$$

in which

p_0 is the reference sound pressure,

ρc is the characteristic acoustic impedance at the time and place of the test, in newton seconds per cubic metre,

P_0 is the reference sound power,

p_s is the static pressure at the time and place of the test, in kilopascals,

$p_{s,0}$ is the reference static pressure, 101,325 kPa,

θ is the air temperature at the time and place of the test, in degrees Celsius,

$\theta_0 = 314 \text{ K}$, is the temperature, when static pressure is equal to $p_{s,0}$, at which sound intensity and sound pressure have identical decibel values when measured in a plane wave,

$\theta_1 = 296 \text{ K}$;

C_3 is the correction for air absorption, in decibels, at specific frequencies (Reference [28]):

$$C_3 = A_0 (1,005 \cdot 3 - 0,001 \cdot 2 \cdot A_0)^{1,6} \text{ dB}$$

in which A_0 is equal to the numerical value of $a(f)r$, where

$a(f)$ is the attenuation coefficient for specific temperature, humidity and static pressure as a function of frequency according to Equations (3) to (5) of ISO 9613-1:1993, expressed in decibels per metre,

r is the measurement radius, expressed in metres.

NOTE 1 At the reference static pressure of 101,325 kPa, the value given for θ_0 is the temperature where sound intensity and sound pressure have identical decibel values when measured in a plane wave. This temperature is a consequence of the historical choice of decibel reference quantity for sound pressure.

NOTE 2 Above 1 kHz, the value for $a(f)$ is roughly proportional to frequency; typically 0,004 dB/m to 0,02 dB/m at 1 000 Hz and rising to 0,1 dB/m to 0,3 dB/m at 10 000 Hz.

NOTE 3 Humidity can also affect sound generation, e.g. a printer printing on paper. In such a case, the allowable humidity range is normally specified in a noise test code.

9.4.4.2 Sound power level in a hemi-anechoic room

In a hemi-free field, the sound power level in each frequency band of interest or A-weighted, as appropriate, L_W , under reference meteorological conditions shall be calculated using Equation (15):

$$L_W = \overline{L_p} + 10 \lg \left(\frac{S_2}{S_0} \right) \text{ dB} + C_1 + C_2 + C_3 \quad (15)$$

where

$\overline{L_p}$ is the surface time-averaged sound pressure level for the noise source under test, in decibels;

S_2 is the area of the hemispherical measurement surface, in square metres;

S_0, C_1, C_2, C_3 see Equation (14).

9.4.4.3 Sound power level under different meteorological conditions

The sound power level that is emitted by the same noise source under different meteorological conditions, $L_{W\text{met}}$, is calculated using the relevant noise test code. In the absence of a noise test code, $L_{W\text{met}}$ may be calculated from L_W using Equation (16), which is valid for a monopole source and is a mean value for other sources (References [25][27]):

$$L_{W\text{met}} = L_W + 10 \lg \frac{p_{s,\text{met}}}{p_{s,0}} \text{ dB} - 15 \lg \left[\frac{(273 + \theta_{\text{met}})}{\theta_1} \right] \text{ dB} \quad (16)$$

where

$p_{s,\text{met}}$ is the static pressure, in kilopascals;

θ_{met} is the air temperature, in degrees Celsius, at which the sound power level is to be calculated.

9.5 Determination of sound energy levels for a noise source which emits impulsive noise

9.5.1 Measurement of single event time-integrated sound pressure levels

For a noise source which emits bursts of noise, measurements shall be made at fixed microphone positions and the measurement surface shall be a sphere or a hemisphere. Single event time-integrated sound pressure levels from the noise source under test, $L_{Ei(\text{ST})}$, (either in one-third-octave frequency bands or A-weighted) shall be obtained at each microphone position, i ($i = 1, 2 \dots N_M$) either for a single sound emission event at a time (in which case the process shall be repeated N_e times, where N_e is at least 5) or from several successive (N_e) sound emission events (where again N_e is a minimum of 5). The single event time-integrated sound pressure levels shall be measured simultaneously at all microphone positions through a time period that encompasses the full burst.

NOTE If the emitted single burst of sound energy has sufficient repeatability, it can be possible to relax the requirement for simultaneous measurement at all microphone positions.

Either immediately before or immediately after the single event time-integrated sound pressure levels from the noise source under test are measured, the time-averaged sound pressure level of the background noise, $L_{pi(\text{B})}$, shall be obtained at each microphone position, over a representative time interval.

9.5.2 Calculation of surface single event time-integrated sound pressure levels

If N_e single event time-integrated sound pressure levels have been measured one at a time at the i th microphone position, the mean single event time-integrated sound pressure level at that position, $L'_{Ei(ST)}$, shall be calculated using Equation (17):

$$L'_{Ei(ST)} = 10 \lg \left[\frac{1}{N_e} \sum_{q=1}^{N_e} 10^{0,1L'_{Ei,q(ST)}} \right] \text{ dB} \quad (17)$$

where

$L'_{Ei,q(ST)}$ is the frequency-band or A-weighted single event time-integrated sound pressure level at the i th microphone position, for the q th event ($q = 1, 2 \dots N_e$) of the noise source under test in operation, in decibels;

N_e is the number of measurements of single sound emission events.

If a single event time-integrated sound pressure level has been measured at the i th microphone position encompassing N_e sound emission events, the mean single event time-integrated sound pressure level at that position for one event, $L'_{Ei(ST)}$ shall be calculated using Equation (18):

$$L'_{Ei(ST)} = L'_{Ei,N_e(ST)} - 10 \lg N_e \text{ dB} \quad (18)$$

The corrections for background noise and the surface single event time-integrated sound pressure levels, $\overline{L_E}$, shall be calculated using the mean single event time-integrated sound pressure levels at the individual microphone positions, in the same way as for the surface time-averaged sound pressure levels described in 9.4.3.

9.5.3 Calculation of sound energy levels

9.5.3.1 Sound energy level in an anechoic room

In a free field, the sound energy level in each frequency band of interest or A-weighted, as appropriate, L_J , under reference meteorological conditions shall be calculated using Equation (19):

$$L_J = \overline{L_E} + 10 \lg \left(\frac{S_1}{S_0} \right) \text{ dB} + C_1 + C_2 + C_3 \quad (19)$$

where

$\overline{L_E}$ is the surface single event time-integrated sound pressure level for the noise source under test, in decibels;

S_1 is the area of the spherical measurement surface, in square metres;

$S_0 = 1 \text{ m}^2$;

C_1 is the reference quantity correction, see 9.4.4.1:

$$C_1 = -10 \lg \frac{p_s}{p_{s,0}} \text{ dB} + 5 \lg \left[\frac{(273 + \theta)}{\theta_0} \right] \text{ dB}$$

C_2 is the acoustic radiation impedance correction, see 9.4.4.1:

$$C_2 = -10 \lg \frac{p_s}{p_{s,0}} \text{ dB} + 15 \lg \left[\frac{(273 + \theta)}{\theta_1} \right] \text{ dB}$$

in which

- p_s is the static pressure at the time and place of the test, in kilopascals,
 $p_{s,0}$ is the reference static pressure, 101,325 kPa,
 θ is the air temperature at the time and place of the test, in degrees Celsius,
 $\theta_0 = 314$ K,
 $\theta_1 = 296$ K;

C_3 is the correction for air absorption, in decibels, at specific frequencies (Reference [28]):

$$C_3 = A_0 (1,005^3 - 0,0012 A_0)^{1,6} \text{ dB}$$

in which A_0 is equal to the numerical value of $\alpha(f) r$, where

$\alpha(f)$ is the attenuation coefficient for specific temperature, humidity and static pressure as a function of frequency in accordance with ISO 9613-1:1993, Equations (3) to (5) expressed in decibels per metre

r is the measurement radius, expressed in metres.

NOTE 1 At the reference static pressure of 101,325 kPa the value given for θ_0 is the temperature where sound intensity and sound pressure have identical decibel values when measured in a plane wave. This temperature is a consequence of the historical choice of decibel reference quantity for sound pressure.

NOTE 2 Above 1 kHz, the value for $\alpha(f)$ is roughly proportional to frequency; typically 0,004 dB/m to 0,02 dB/m at 1 000 Hz and rising to 0,1 dB/m to 0,3 dB/m at 10 000 Hz.

NOTE 3 Humidity can also affect sound generation, e.g. a printer printing on paper. In such a case, the allowable humidity range is normally specified in a noise test code.

9.5.3.2 Sound energy level in a hemi-anechoic room

In a hemi-free field, the sound energy level in each frequency band of interest or A-weighted, as appropriate, L_J , under reference meteorological conditions shall be calculated using Equation (20):

$$L_J = \overline{L_E} + 10 \lg \left(\frac{S_2}{S_0} \right) \text{ dB} + C_1 + C_2 + C_3 \quad (20)$$

where

$\overline{L_E}$ is the surface single event time-integrated sound pressure level for the noise source under test, in decibels;

S_2 is the area of the hemispherical measurement surface, in square metres;

S_0, C_1, C_2, C_3 see Equation (19).

9.6 Calculation of directivity indices

The directivity index in the direction of the i th microphone position, D_{li} , shall be calculated using Equation (21):

$$D_{li} = L_{pi} - \overline{L_p} \quad (21)$$

where

L_{pi} is the sound pressure level at the i th microphone position, corrected for background noise, in decibels;

$\overline{L_p}$ is the surface time-averaged sound pressure level, in decibels.

9.7 Calculation of surface sound pressure level non-uniformity index

If required, the non-uniformity index over the measurement surface, V_{lr} , at a particular measurement radius, r , shall be calculated using Equation (22):

$$V_{lr} = \sqrt{\frac{1}{N_M - 1} \sum_{i=1}^{N_M} (L_{pi} - L_{pav})^2} \quad (22)$$

where

L_{pi} is the time-averaged sound pressure level at the i th microphone position, corrected for background noise, in decibels;

L_{pav} is the arithmetic average of the time-averaged sound pressure levels on the measurement surface, in decibels;

N_M is the number of microphone positions.

9.8 Frequency-weighted sound power level and sound energy level

Calculation of L_{WA} or L_{JA} of the noise source under test from measurements made in frequency bands, shall be performed using the procedure specified in Annex C.

For sources in which the A-weighted sound power or sound energy levels are predominantly determined by sound at high or low frequencies outside the nominal frequency range of interest (see 3.11), the frequency range of interest shall be extended to include these frequencies in the calculation of L_{WA} or L_{JA} , and this shall be made clear in the test report.

10 Measurement uncertainty

10.1 Methodology

The measurement uncertainties associated with sound power levels and sound energy levels determined in accordance with this International Standard should be evaluated in accordance with the procedure outlined in Annex I. If knowledge is insufficient to apply Annex I, the following procedure may be used.

The uncertainties of sound power levels, $u(L_W)$, in decibels, and sound energy levels, $u(L_J)$, in decibels, determined in accordance with this International Standard are estimated by the total standard deviation, σ_{tot} , in decibels:

$$u(L_W) \approx u(L_J) \approx \sigma_{tot} \quad (23)$$

This total standard deviation is obtained using the modelling approach described in ISO/IEC Guide 98-3. This requires a mathematical model which in case of lack of knowledge can be substituted with results from measurements, including results from round robin tests.

In this context, this standard deviation is expressed by the standard deviation of reproducibility of the method, σ_{R0} , in decibels, and the standard deviation, σ_{omc} , in decibels, describing the uncertainty due to the instability of the operating and mounting conditions of the source under test in accordance with Equation (24):

$$\sigma_{tot} = \sqrt{\sigma_{R0}^2 + \sigma_{omc}^2} \quad (24)$$

Equation (24) shows that variations of operating and mounting conditions expressed by σ_{omc} should be taken into account before a measurement procedure with a certain grade of accuracy (characterized by σ_{R0}) is selected for a specific machine family (see 10.5 and Annex I.3).

NOTE If different measurement procedures offered by the ISO 3741^[3] to ISO 3747^[8] series are used, systematic numerical deviations (biases) can additionally occur.

Derived from σ_{tot} , the expanded measurement uncertainty U , in decibels, shall be calculated from

$$U = k\sigma_{\text{tot}} \quad (25)$$

The expanded measurement uncertainty depends on the degree of confidence that is desired. For a normal distribution of measured values, there is a 95 % confidence that the true value lies within the range $(L_W - U)$ to $(L_W + U)$, [or $(L_J - U)$ to $(L_J + U)$]. This corresponds to a coverage factor of $k = 2$.

If the purpose of determining the sound power level is to compare the result with a limit value, it might be more appropriate to apply the coverage factor for a one-sided normal distribution. In that case, the coverage factor $k = 1,6$ corresponds to a 95 % confidence.

10.2 Determination of σ_{omc}

The standard deviation σ_{omc} [see Equation (I.1)] which describes the uncertainty associated with the instability of the operating and mounting conditions for the particular source under test shall be taken into account when determining the measurement uncertainty. It can be determined separately from repeated measurements carried out on the same source at the same location by the same persons, using the same measuring instruments and the same measurement position(s). To determine σ_{omc} , repeated sound pressure levels are measured either at the microphone position associated with the highest sound pressure level, $L_{pi(\text{ST})}$ or measured and averaged over the entire measurement surface, $\overline{L_{p(\text{ST})}}$. Measurements are corrected for background noise. For each of these repeated measurements, the mounting of the machine and its operating conditions are to be readjusted. For the individual noise source under test, σ_{omc} is designated as σ'_{omc} . It is possible that a noise test code provides a value of σ_{omc} which is representative for the machine family concerned. This value should take into account all possible variations of operating and mounting conditions that are within the scope of the noise test code.

NOTE If the sound power has only a small variation with time and the measurement procedure is defined properly, a value of 0,5 dB for σ_{omc} can apply. In other cases, e.g. a large influence of the material flow into and out of the machine or material flow that varies in an unforeseeable manner, it is possible that a value of 2 dB is appropriate. However, in extreme cases such as strongly varying noise generated by the processed material (stone-breaking machines, metal-cutting machines and presses operating under load) a value of 4 dB can result.

10.3 Determination of σ_{R0}

10.3.1 General

The standard deviation σ_{R0} includes uncertainty due to all conditions and situations allowed by this International Standard (different radiation characteristics of the source under test, different instrumentation, different implementations of the measurement procedure) except that due to instability of the sound power of the source under test. The latter is considered separately by σ_{omc} .

The values of σ_{R0} given in Tables 2 and 3 reflect knowledge at the time of publication. They are typical upper bounds taking into consideration the great variety of machines and equipment covered by this International Standard. Machinery-specific values may be derived from round robin tests (see 10.3.2) or by using the mathematical modelling approach (see 10.3.3). They should be given in noise test codes specific to machinery families (see 10.2 and Annex I).

10.3.2 Round robin test

The round robin test for determining σ_{R0} shall be carried out in accordance with ISO 5725, where the sound power level of the source under test is determined under reproducibility conditions i.e. different persons carrying out measurements at different testing locations with different measuring instruments. Such a test provides the total standard deviation, σ'_{tot} , relevant for the individual sound source which has been used for the round robin test. Participating laboratories in round robin tests should cover all possible practical situations.

This total standard deviation, σ'_{tot} , in decibels, of all results obtained with a round robin test includes the standard deviation σ'_{omc} and allows σ'_{R0} to be determined by using

$$\sigma'_{R0} = \sqrt{\sigma'_{\text{tot}}{}^2 - \sigma'_{\text{omc}}{}^2} \quad (26)$$

If σ'_{R0} values obtained from many different pieces of machinery belonging to the same family deviate within a small range only, their mean value can be regarded as typical for the application of this International Standard to this particular family and used as σ_{R0} . Whenever available, such value should be given in the noise test code specific to the machine family concerned (together with σ_{omc}) and used in particular for the purpose of declaring noise emission values.

If no round robin test has been carried out, existing knowledge about the noise emission from a particular family of machines may be used to estimate realistic values of σ_{R0} .

For certain applications the effort for the round robin test can be reduced by omitting measurements for different locations, e.g. if machines under test usually are installed under conditions with a small background noise correction K_1 or if the noise emission of a machine is rechecked at the same location. Results of such delimited tests should be denoted by $\sigma_{R0,DL}$.

Values for $\sigma_{R0,DL}$ can be expected to be lower than those given in Tables 2 or 3.

The determination of σ_{R0} using Equation (26) is imprecise if σ_{tot} is only slightly higher than σ_{omc} . In this case, Equation (26) provides a small value of σ_{R0} but with a low accuracy. To limit this inaccuracy, σ_{omc} should not exceed $\sigma_{\text{tot}} / \sqrt{2}$.

10.3.3 Modelling approach for σ_{R0}

Generally σ_{R0} , in decibels, is dependent upon several partial uncertainty components, $c_i u_i$, associated with the different measurement parameters such as uncertainties of instruments, environmental corrections, and microphone positions. Using the modelling approach presented in ISO/IEC Guide 98-3, σ_{R0} can be described by:

$$\sigma_{R0} \approx \sqrt{(c_1 u_1)^2 + (c_2 u_2)^2 + \dots + (c_n u_n)^2 + 2 \sum_{i=1}^{N-1} \sum_{j=i+1}^N c_i c_j u(x_i, x_j)} \quad (27)$$

where $u(x_i, x_j)$ is the covariance associated with the i th and j th uncertainty components.

For consistency with Equation (24), in Equation (27) the uncertainty components due to the instability of the sound emission of the source are not included. These components are covered by σ_{omc} . Knowledge of each component of the uncertainty σ_{R0} at the time of publication is summarized in Annex I.

NOTE Round robin tests are not always possible and are often replaced by experience from earlier measurements.

10.4 Typical upper bound values of σ_{R0}

This International Standard provides results of accuracy grade 1. Tables 2 and 3 show typical values of the standard deviation σ_{R0} that may cover most of the applications of this International Standard. In special cases or if certain requirements of this International Standard are not met for a machine family or if it is anticipated that actual values of σ_{R0} for a given family of machines are smaller than those given in Tables 2 or 3, a round robin test is recommended to obtain machine-specific values of σ_{R0} .

Table 2 — Typical upper bound values of the standard deviation of reproducibility of the method, σ_{RO} , for sound power levels and sound energy levels determined in a hemi-anechoic room in accordance with this International Standard

Frequency bandwidth	One-third-octave mid-band frequency Hz	Standard deviation of reproducibility, σ_{RO} dB
One-third octave	50 to 80 ^a	2,0
	100 to 630	1,5
	800 to 5 000	1,0
	6 300 to 10 000	1,5
	12 500 to 20 000 ^b	2,0
A-weighted		0,5
^a If the sound field is qualified in accordance with Clause 5.		
^b If the instrumentation allows and if correction is made for absorption of sound by the atmosphere.		

Table 3 — Typical upper bound values of the standard deviation of reproducibility of the method, σ_{RO} , for the sound power levels and sound energy levels determined in an anechoic room, in accordance with this International Standard

Frequency bandwidth	One-third-octave mid-band frequency Hz	Standard deviation of reproducibility, σ_{RO} dB
One-third octave	50 to 80 ^a	2,0
	100 to 630	1,0
	800 to 5 000	0,5
	6 300 to 10 000	1,0
	12 500 to 20 000 ^b	2,0
A-weighted		0,5
^a If the sound field is qualified in accordance with Clause 5.		
^b If the instrumentation allows and if correction is made for absorption of sound by the atmosphere.		

10.5 Total standard deviation, σ_{tot} , and expanded measurement uncertainty, U

The total standard deviation and the expanded measurement uncertainty shall be determined using Equation (24) and Equation (25), respectively.

EXAMPLE Coverage factor, $k = 2$; measured $L_{pA} = 82$ dB; $\sigma_{omc} = 2,0$ dB. Machine-specific determinations of σ_{RO} have not been undertaken, thus the value is taken from Table 2 ($\sigma_{RO} = 0,5$ dB). Using Equations (25) and (24) it follows

$$U = 2 \times \sqrt{0,5^2 + 2,0^2} \text{ dB} = 4,1 \text{ dB}$$

Additional examples of calculated values for σ_{tot} are given in Clause I.3.

NOTE The expanded uncertainty, as described in this International Standard, does not include the standard deviation of production which is used in ISO 4871^[9] for the purpose of making a noise declaration for batches of machines.

11 Information to be recorded

11.1 General

The information listed in 11.2 to 11.5, when applicable, shall be compiled and recorded for all measurements made in accordance with this International Standard.

11.2 Noise source under test

The following information shall be recorded:

- a) a description of the noise source under test (including the manufacturer, type, technical data, dimensions, serial number and year of manufacture);
- b) a description of any treatment of auxiliary equipment for the purpose of the test;
- c) the mode(s) of operation used for the test(s) and the relevant measurement interval(s);
- d) the mounting conditions;
- e) the location(s) of the noise source in the test room.

11.3 Test room

The following information shall be recorded:

- a) a description of the test room and whether it provides a free field or a hemi-free field, including the dimensions in metres, the surface treatment of the walls, ceiling and floor and a sketch showing the location of source and room contents;
- b) a description of the acoustical qualification of the room and whether it was performed in accordance with Annex A or Annex B;
- c) the air temperature in degrees Celsius, the relative humidity expressed as a percentage, and the static pressure in kilopascals, in the room at the time of test.

11.4 Instrumentation

The following information shall be recorded:

- a) the equipment used for the measurements, including the name, type, serial number and manufacturer;
- b) the date, place, and methods used to calibrate the sound calibrator and to verify the calibration of the instrumentation system, in accordance with 6.2.

11.5 Acoustical data

The following information shall be recorded:

- a) the microphone positions or path(s) used for the measurements (with a sketch if necessary) including any regions where the positions are associated with unequal areas of the measurement surface;

For each mode of operation under which the noise source was tested:

- b) all measured sound pressure levels, whether time-averaged or single event time-integrated, in the test room from the noise source under test;
- c) any corrections, in decibels, to account for background noise;
- d) the surface time-averaged sound pressure levels or surface single event time-integrated sound pressure levels;

- e) the sound power levels or sound energy levels in decibels, in frequency bands or A-weighted, as appropriate, rounded to the nearest 0,1 dB; a graphical representation may optionally be recorded in addition;
- f) the expanded measurement uncertainty of the results, in decibels, together with the associated coverage factor and coverage probability;
- g) if required, the maximum directivity index and the direction in which it applies;
- h) if required, the surface sound pressure level non-uniformity index at the applicable measurement radius;
- i) the date and time when the measurements were performed.

12 Test report

Only those recorded data (see Clause 11) which are required for the purpose of the measurements shall be reported. The report shall also contain any statements required to be reported by certain clauses in the main body of this International Standard. If the reported sound power levels or sound energy levels have been obtained in full conformity with the requirements of this International Standard, the report shall state this fact. If the levels have not been obtained in full conformity, the report shall not state or imply that they have been. If one or a small number of identifiable discrepancies exist between the reported levels and the requirements of this International Standard, then the report may state that the measurements have been conducted “in conformity with the requirements of this International Standard, except for...” and the discrepancies clearly identified. In this case, the term “full conformity” shall not be stated or implied.

Annex A (normative)

General procedures for qualification of anechoic and hemi-anechoic rooms

NOTE It is anticipated that future revisions of this annex will make reference to ISO 26101^[21].

A.1 General

The performance of an anechoic or a hemi-anechoic room is assessed by comparing the spatial decrease of sound pressure emitted from a test sound source with the decrease of sound pressure with distance from the source in accordance with the inverse square law that would occur in a true free field or hemi-free field.

NOTE A check of the room performance is recommended after modification of the room absorbers and periodically at intervals not exceeding 5 years.

A.2 Instrumentation and measuring equipment

A.2.1 General

The instrumentation system, including the microphones and cables, shall meet the requirements of IEC 61672-1:2002, class 1. The filters used shall meet the requirements of IEC 61260:1995, class 1.

A.2.2 Test sound source type

A.2.2.1 General

A sound source approximating a point source over the frequency range of interest shall be used for the qualification. The source shall meet the performance requirements in A.2.2.2 and be:

- a) compact with an identifiable centre (to provide a good reference for the origin of the microphone traverses specified in A.3.3);
- b) relatively omnidirectional (to have energy incident on all the room surfaces in roughly equal proportions);
- c) able to generate sufficient sound output over the frequency range of interest to yield sound pressure levels 10 dB above the background noise levels for all points on each microphone traverse; and
- d) of high stability so that the radiated sound power does not change during measurements along the microphone traverse.

The design or selection of the test source is the responsibility of the laboratory in which the qualification is performed. One or more sources may be used to cover the overall frequency range of interest, but the requirements given in A.2.2.1 and A.2.2.2 shall be met for each source over its applicable frequency range.

The sound power level of the test source (with the associated signal generation and amplification electronics) should not vary by more than $\pm 0,5$ dB in any one-third-octave band in the frequency range of interest during the measurements for each microphone traverse (see next paragraph). This can be demonstrated by determining the band sound power levels of the sound source, in accordance with the methods of this International Standard, repeatedly over a period of time corresponding to a typical microphone traverse and noting the deviations.

It is advisable to employ a “monitoring microphone” located at an arbitrary but fixed position in the room in order to verify that the source output during the test complies with the foregoing.

A.2.2.2 Test sound source directivity

The directivity of the test source shall be uniform to within the allowable deviations given in Table A.1 when determined in accordance with the following procedure. However, a traverse line shall not be mounted in such a way that the microphone passes through the nodes of a loudspeaker.

The test source shall be installed in its normal qualification position in the centre of the test room and operated at an output level representative of the level to be used for the room qualification. A spherical co-ordinate system shall be selected with the source at the centre, $r = 0$ m, and with the plane for angle of elevation, $\theta = 90^\circ$ corresponding to the rigid floor for a hemi-anechoic room or to a plane parallel with the floor and ceiling in an anechoic room (see Figure A.1). The plane with the angle of azimuth, $\varphi = 0^\circ$ (or 90° , 180° , 270°) shall be parallel to the walls of the room if the room is rectangular. The position $r = 1,5$ m, $\varphi = 0^\circ$ shall be selected and the one-third-octave band sound pressure levels at $\theta = 80^\circ$, 60° , 40° and 20° shall be measured. For a source used in the qualification of an anechoic room, additional measurements shall be made at $\theta = 100^\circ$, 120° , 140° and 160° . For each angle θ , measurements shall be made at $\varphi = 0^\circ$, 45° , 90° , 135° , 180° , 225° , 270° , and 315° , for a total of 32 measurements in a hemi-anechoic room or 64 measurements in an anechoic room. For each one-third-octave band, the arithmetic mean of the decibel levels and the maximum positive and negative deviations from the mean shall be computed. If the deviations are within the allowable limits, the test source is suitable for conducting the qualification. A position directly above the source at $\theta = 0^\circ$ may be added for information and as a check on the stability of the sound source, but it is not required for determining the directivity of the source.

Table A.1 — Allowable deviation in directivity of the test source

Type of test room	One-third-octave-band frequency Hz	Allowable deviation in directivity dB
Anechoic (free-field)	≤ 630	$\pm 1,5$
	800 to 5 000	$\pm 2,0$
	6 300 to 10 000	$\pm 2,5$
	$> 10\ 000$	$\pm 5,0$
Hemi-anechoic (hemi-free-field)	≤ 630	$\pm 2,0$
	800 to 5 000	$\pm 2,5$
	6 300 to 10 000	$\pm 3,0$
	$> 10\ 000$	$\pm 5,0$

For the directivity measurements, the source may be installed and evaluated in a different anechoic or hemi-anechoic room than the one being qualified (e.g. one known to have good free-field properties over the frequency range of interest).

Sources suitable for use in qualification for anechoic and hemi-anechoic rooms are described in References [30]–[34].

For qualification of a hemi-anechoic room, it is useful to have a small cavity in the centre of the floor. The purpose of the cavity is to install a source whose radiating surface is in the plane of the floor. The outlet diameter in the floor should be less than 20 mm for use with frequencies above 4 kHz; at lower frequencies, a larger diameter outlet may be acceptable.

At frequencies below 800 Hz, sources meeting the requirements of ISO 140-3^[1] may be suitable. A possible alternative is an electro-dynamic loudspeaker in a sealed box having dimensions less than $\lambda/10$, where λ is wavelength.

For frequencies up to 10 kHz, a source that may be suitable is an acoustically shielded compression driver attached to a tapered cylindrical tube. The tube should have an outer diameter less than 10 mm for use with frequencies above 4 kHz, at lower frequencies, a larger diameter tube may be acceptable. Use of a long tube of up to 1,5 m in length moves the driver away from the outlet, which reduces shielding effects, and improves the frequency response by increasing the modal density.

It is advisable to use a source that meets the directivity requirements of A.2.2.2 at the start of the measurement traverse (see A.4.2) at a radius of 0,5 m from the source. Sources tend to be more omnidirectional in the far field, and any difference in source directivity in the near and far field makes it more difficult to qualify the test room.

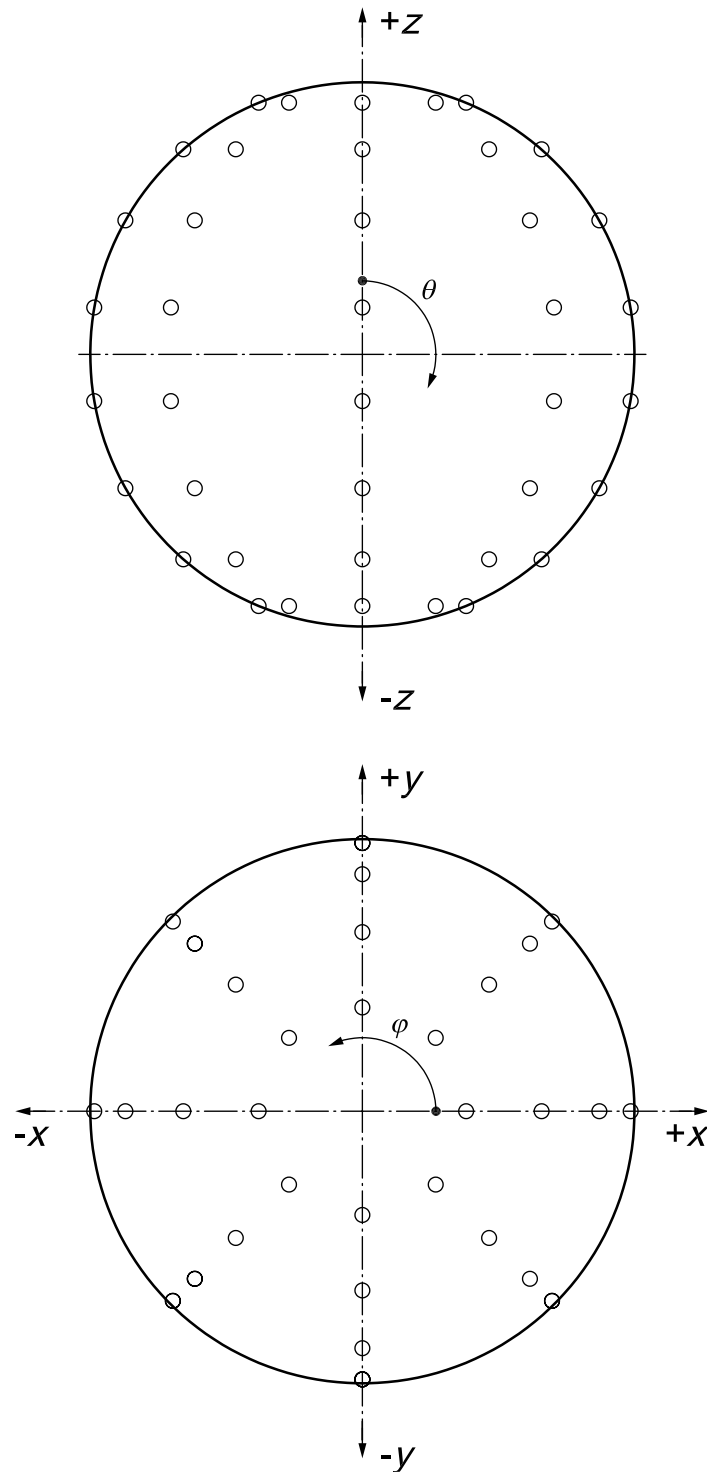

Figure A.1 — Microphone positions on the spherical surface for test sound source directivity measurements

A.3 Installation of test sources and microphones

A.3.1 Anechoic rooms

The test sound source shall be located so that the assumed position of the acoustic centre coincides as closely as possible with a point identified as the geometric centre of the measurement sphere, preferably in the centre of the room.

A.3.2 Hemi-anechoic rooms

A.3.2.1 General

The test sound source shall be located so that the assumed position of the acoustic centre coincides as closely as possible with a point identified as the geometric centre of the measurement hemisphere, preferably in the centre of the floor of the room.

The test sound source should be located on the plane of the reflecting floor, so that the acoustic centre of the test source is situated as close as possible to, but in any case should not be greater than 150 mm from, the reflecting floor. If possible, the acoustic centre of the test source should be within $\lambda/10$ from the reflecting floor for all frequencies in the frequency range of interest. Therefore, it is recommended to install the test source in a cavity in the reflecting floor (see A.2.2.2, paragraph 5).

A.3.2.2 Size of reflecting plane

The reflecting plane shall extend at least $\lambda/4$ and not less than 0,75 m beyond the projection of the measurement surface on the plane for the lowest frequency of the frequency range of interest.

A.3.2.3 Sound absorption coefficient

The sound absorption coefficient of the reflecting plane shall be less than 0,06 over the frequency range of interest.

NOTE A sealed concrete construction or a sealed lightweight construction with a surface density of 20 kg/m² or more, provided there are no significant air mass or structural resonances in the frequency range of interest, complies with the requirement.

A.3.3 Microphone traverse

Microphone traverses shall be made along at least five straight paths away from the geometric centre of the measurement sphere or hemisphere in different directions. Key microphone paths are the lines from the geometric centre of the measurement sphere or hemisphere to the room corners (where corner refers to the intersection of two walls and the ceiling or two walls and the floor), and lines normal to the wall (or ceiling) surfaces. The key paths to the corners shall comprise three of the five required traverses, and one path shall lead to the nearest wall, ceiling or floor surface. In an anechoic room, the three selected corners shall be located in the working area of the room, i.e. the part of the room normally used for measurements. When there is no clear working area in an anechoic room, the selected corners shall lie in an imaginary plane that passes through the centre of the room. In a hemi-anechoic room, paths at an angle of less than 20° above the reflecting floor should be avoided.

The geometric centre of the measurement sphere shall be within 200 mm of a reference box that encloses the test source.

The test sound source should be placed in a chosen orientation and held in that orientation for all microphone traverses.

Where the acoustic centre of the test source is not clearly identifiable, a point representing the centre should be selected appropriately and used uniformly throughout the qualification procedure. This point is used for measurement only; the actual location of the acoustic centre is calculated in A.4.3.1.

A.4 Test procedures

A.4.1 Generation of sound

The test source specified in A.2.2 shall be operated at discrete frequencies that cover, in sequential steps, the entire frequency range over which the test room is being qualified. Analysis shall be made in one-third-octave bands in sequential steps that cover the entire frequency range over which the test room is being qualified. Below 125 Hz and above 4 000 Hz, the sequential steps shall correspond to the mid-band frequencies of contiguous one-third-octave bands, and between 125 Hz and 4 000 Hz, the steps shall correspond to the mid-band frequencies of contiguous octave bands (i.e. between 125 Hz and 4 000 Hz, not all one-third-octave bands need be used).

If the machine under test radiates only broadband noise, the procedure may be carried out using random noise instead of discrete frequencies.

Use of a mix of pure tones spaced apart by more than one frequency band can be much more rapid than sequential traverses, each at a single pure tone. If random noise is used, measurement times shall be long enough to achieve stable levels.

A.4.2 Measurement of sound pressure level

The microphone shall be moved along the paths described in A.3.3 for each test signal. The measurement of sound pressure level shall be carried out starting 0,5 m from the acoustic centre of the loudspeaker and ending at or beyond the measurement surface the user wishes to qualify. Sound pressure levels shall be measured along each microphone traverse using equally spaced measurement points. For a measurement surface to be qualified in accordance with this International Standard, it shall enclose at least 10 measurement points along each of the five microphone traverses (a total of at least 50 points). In addition, the spacing between measurement points shall not exceed 0,1 m.

Alternatively, the microphone shall be moved slowly and continuously along the traverse and the sound pressure levels recorded.

Sound reflection from the microphone traverse system shall be carefully avoided.

Due to the long averaging time required to measure random noise, a continuous traverse is only recommended for use with pure tone signals.

A.4.3 Determination of deviations from the inverse square law

A.4.3.1 Equation for estimation of sound pressure levels based on the inverse square law

From the sound pressure levels measured at positions specified in A.4.2, the estimation of sound pressure levels based on the inverse square law shall be determined for each direction of measurement. The sound pressure level at the i th position within the region to be qualified, $L_p(r_i)$, is given by Equation (A.1):

$$L_p(r_i) = 20 \lg \left[\frac{a}{r_i - r_0} \right] \text{ dB} \quad (\text{A.1})$$

where

a is a constant related to the sound power emitted from the test sound source:

$$a = \frac{Mr_0^2 + \sum_{i=1}^M r_i^2 - 2r_0 \sum_{i=1}^M r_i}{\sum_{i=1}^M r_i q_i - r_0 \sum_{i=1}^M q_i};$$

r_i is the distance of the i th measurement position from the centre of the measurement sphere or hemisphere;

r_0 is the collinear offset of the acoustic centre along the axis of the microphone traverse — it is a measurement of the separation between the acoustic centre of the source and the origin of the microphone traverse, whose apparent position is given by:

$$r_0 = - \left[\frac{\sum_{i=1}^M r_i \sum_{i=1}^M r_i q_i - \sum_{i=1}^M r_i^2 \sum_{i=1}^M q_i}{\sum_{i=1}^M r_i \sum_{i=1}^M q_i - M \sum_{i=1}^M r_i q_i} \right]$$

NOTE 1 For a source with a well-defined acoustic centre (such as those described in A.2.2.2 paragraphs 5 and 7), the origin of the traverse can be expected to coincide with the acoustic centre and r_0 is identically equal to zero. If the calculated value of $|r_0|$ exceeds 200 mm, it is possible that there are problems with either the test room or the sound source.

NOTE 2 Source parameters a , r_0 , are determined near the source and extrapolated to larger distances using Equation (A.1) for room characterization. Determination of source parameters a , r_0 , using data that are strongly influenced by room reflections can lead to inappropriate results. The use of Equation (A.1) can be problematic due to the growth of the near field of the source when used at frequencies below 100 Hz.

in which

$$q_i = 10^{-0,05 L_{pi}}$$

where L_{pi} is the sound pressure level at the i th measurement position, in decibels;

M is the number of measurement positions along each microphone traverse within the region where the inverse square law is followed (assumes that data points near the end of a traverse may be discarded).

Other methods may be used to estimate the sound pressure level on the inverse square law provided they allow calculation of $L_p(r_i)$ as in Equation (A.1).

If a continuous traverse is used, an analogue recording of level versus distance is obtained. To use the equations in this Annex, sound pressure levels at a large number of points, at regularly spaced intervals should be derived from the records. The selection of point spacing should be based on the criteria of A.4.2.

A.4.3.2 Deviations from the inverse square law

Using the estimation of sound pressure levels based on the inverse square law, deviations of the sound pressure levels at all measurement positions from the inverse square law are determined by Equation (A.2):

$$\Delta L_{pi} = L_{pi} - L_p(r_i) \tag{A.2}$$

where

ΔL_{pi} is the deviation from the inverse square law, in decibels;

L_{pi} is the sound pressure level at the i th measurement position, in decibels;

$L_p(r_i)$ see Equation (A.1).

A.5 Qualification procedure

The deviations of measured sound pressure levels from those estimated using the inverse square law obtained in accordance with A.4.3.2 shall not exceed the values given in Table A.2.

Table A.2 — Maximum allowable deviation of measured sound pressure levels from theoretical levels using the inverse square law

Type of test room	One-third-octave band frequency Hz	Allowable deviation dB
Anechoic (free-field)	≤630	±1,5
	800 to 5 000	±1,0
	≥6 300	±1,5
Hemi-anechoic (hemi-free-field)	≤630	±2,5
	800 to 5 000	±2,0
	≥6 300	±3,0

NOTE A test room to be qualified for pure tones is more costly both to construct and to qualify than one to be qualified for one-third-octave band random noise.

The deviations in Table A.2 determine the largest space surrounding the noise source under test within which a measurement surface may be chosen. If the measurement surface thus determined lies outside the near field of the noise source to be tested, this measurement surface is suitable for the determination of sound power levels and sound energy levels in accordance with this International Standard.

The deviations in Table A.2 also determine the frequency range over which measurements can be made in accordance with this International Standard. If the range is not at least 100 Hz to 10 kHz (see 3.11), measurements taken in this test room are not in *full* conformity with this International Standard. If the test room is qualified over a reduced frequency range, measurements may still be reported to be “in conformity” with this International Standard provided that:

- a) the one-third-octave bands comprising the reduced frequency range are contiguous;
- b) the report clearly states the reduced frequency range;
- c) the words “in full conformity with ISO 3745” are not used or implied.

Annex B (normative)

Qualification procedure for spaces within test rooms used in the determination of sound power levels and sound energy levels of specific noise sources

B.1 General

The purpose of the procedure in this annex is to provide a qualification of a space within the test room for the determination of the sound power or sound energy of a specific sound source that may be under test in accordance with this International Standard. This procedure is not an alternative to Annex A for qualifying the test room itself.

An environment providing a free field or a free field over a reflecting plane shall be used for measurements made in accordance with this International Standard.

The test room shall be large enough and free from reflecting objects, with the exception of the reflecting plane in a hemi-anechoic room.

The test room shall provide a measurement surface that lies:

- a) in a sound field that is free of undesired sound reflections from the room boundaries;
- b) outside the near field of the sound source under test.

Procedures are described in this annex to determine the undesired environmental influences, if any, and to confirm the free-field or hemi-free-field conditions. For measurements in hemi-anechoic rooms, the reflecting plane shall satisfy the requirements given in B.2.

B.2 Properties of reflecting plane

B.2.1 General

In the case of hemi-anechoic rooms, measurements shall be made over a reflecting plane in a test room in which one of the surfaces is reflecting.

Particularly when the reflecting surface is not a ground plane or is not an integral part of a test room surface, care shall be exercised to ensure that the plane does not radiate any appreciable sound due to vibration.

B.2.2 Size

The reflecting plane shall extend at least $\lambda/4$ and not less than 0,75 m beyond the projection of the measurement surface on the plane for the lowest frequency of the frequency range of interest.

B.2.3 Sound absorption coefficient

The sound absorption coefficient of the reflecting plane shall be less than 0,06 over the frequency range of interest.

NOTE The requirement is complied with by a sealed concrete construction or a sealed light weight construction with a surface density of 20 kg/m² or more, provided there are no significant air mass or structural resonances in the frequency range of interest.

B.3 Procedure using two measurement spheres or hemispheres with different radii (two-surface method)

B.3.1 Test sound source

In general, the noise source to be tested is used as the test sound source for the qualification procedures.

The measurement surface is qualified only for the test sound source or sound sources that are similar in size and directivity.

B.3.2 Procedures

Two spherical surfaces (for an anechoic room) or two hemi-spherical surfaces (for a hemi-anechoic room) that surround the sound source are first selected. The first surface shall be the measurement surface, in accordance with Clause 8, for the determination of sound power levels or sound energy levels. The area of the first surface shall be designated as S_1 . The second surface, with area S_2 , shall be geometrically similar to the first surface, located further away and symmetrical with respect to the sound source. On both surfaces, the background noise criteria specified in 5.3 shall be fulfilled.

The microphone locations on the second surface shall correspond to those on the first surface. The quotient S_2/S_1 shall be not less than 2 and preferably should be greater than 4.

From the measurements of average sound pressure levels over both surfaces S_1 and S_2 , the following quantity is calculated for the respective frequencies:

$$\delta = \overline{L_{p1}} - \overline{L_{p2}} - 10 \lg \frac{S_2}{S_1} \text{ dB} \quad (\text{B.1})$$

where

$\overline{L_{p1}}$ is the surface time-averaged sound pressure level on S_1 , in decibels;

$\overline{L_{p2}}$ is the surface time-averaged sound pressure level on S_2 , in decibels.

If the values of $|\delta|$ are equal to or less than 0,5 dB, the test room and the measurement surface S_1 are considered to be appropriate for the purpose of this International Standard.

Annex C (normative)

Calculation of A-weighted sound power levels and A-weighted sound energy levels from one-third-octave band levels

C.1 A-weighted sound power levels

The A-weighted sound power level, L_{WA} , shall be calculated from Equation (C.1):

$$L_{WA} = 10 \lg \sum_{j=j_{\min}}^{j_{\max}} 10^{0,1(L_{W,j}+C_j)} \text{ dB} \quad (\text{C.1})$$

where

- $L_{W,j}$ is the sound power level in the j th one-third octave, in decibels;
- j, C_j are given in Table C.1;
- j_{\min}, j_{\max} are the values of j corresponding, respectively, to the lowest and highest one-third-octave bands of measurement.

C.2 A-weighted sound energy levels

The A-weighted sound energy level, L_{JA} , shall be calculated from Equation (C.2):

$$L_{JA} = 10 \lg \sum_{j=j_{\min}}^{j_{\max}} 10^{0,1(L_{J,j}+C_j)} \text{ dB} \quad (\text{C.2})$$

where

- $L_{J,j}$ is the sound energy level in the j th one-third octave, in decibels;
- j, C_j are given in Table C.1;
- j_{\min}, j_{\max} are the values of j corresponding, respectively, to the lowest and highest one-third-octave bands of measurement.

C.3 Values of j and C_j for use in calculations

For calculations with one-third-octave band data, values of j and C_j are given in Table C.1.

Table C.1 — Values of j and C_j for mid-band frequencies of one-third-octave bands

j	One-third-octave mid-band frequency	C_j
	Hz	dB
1	50	-30,2 ^a
2	63	-26,2 ^a
3	80	-22,5 ^a
4	100	-19,1
5	125	-16,1
6	160	-13,4
7	200	-10,9
8	250	-8,6
9	315	-6,6
10	400	-4,8
11	500	-3,2
12	630	-1,9
13	800	-0,8
14	1 000	0,0
15	1 250	0,6
16	1 600	1,0
17	2 000	1,2
18	2 500	1,3
19	3 150	1,2
20	4 000	1,0
21	5 000	0,5
22	6 300	-0,1
23	8 000	-1,1
24	10 000	-2,5

^a These values of C_j are given for use only where the test room and instrumentation are satisfactory for use at the frequencies concerned.

Annex D

(normative)

Array of microphone positions on a spherical measurement surface in a free field

The co-ordinates of 40 positions associated with equal areas on the surface of a sphere of radius r , with the origin at the acoustic centre of the noise source under test, are given in Table D.1, and illustrated in Figure D.1. The z -axis is chosen perpendicularly upward from a horizontal plane ($z = 0$).

Table D.1 — Microphone positions

Position number	x/r	y/r	z/r
1	-0,999	0	0,050
2	0,494	-0,856	0,150
3	0,484	0,839	0,250
4	-0,468	0,811	0,350
5	-0,447	-0,773	0,450
6	0,835	0	0,550
7	0,380	0,658	0,650
8	-0,661	0	0,750
9	0,263	-0,456	0,850
10	0,312	0	0,950
11	0,999	0	-0,050
12	-0,494	0,856	-0,150
13	-0,484	-0,839	-0,250
14	0,468	-0,811	-0,350
15	0,447	0,773	-0,450
16	-0,835	0	-0,550
17	-0,380	-0,658	-0,650
18	0,661	0	-0,750
19	-0,263	0,456	-0,850
20	-0,312	0	-0,950
21	0,999	0	0,050
22	-0,494	-0,856	0,150
23	-0,484	0,839	0,250
24	0,468	0,811	0,350
25	0,447	-0,773	0,450
26	-0,835	0	0,550
27	-0,380	0,658	0,650
28	0,661	0	0,750
29	-0,263	-0,456	0,850
30	-0,312	0	0,950
31	-0,999	0	-0,050
32	0,494	0,856	-0,150
33	0,484	-0,839	-0,250
34	-0,468	-0,811	-0,350
35	-0,447	0,773	-0,450
36	0,835	0	-0,550
37	0,380	-0,658	-0,650
38	-0,661	0	-0,750
39	0,263	0,456	-0,850
40	0,312	0	-0,950

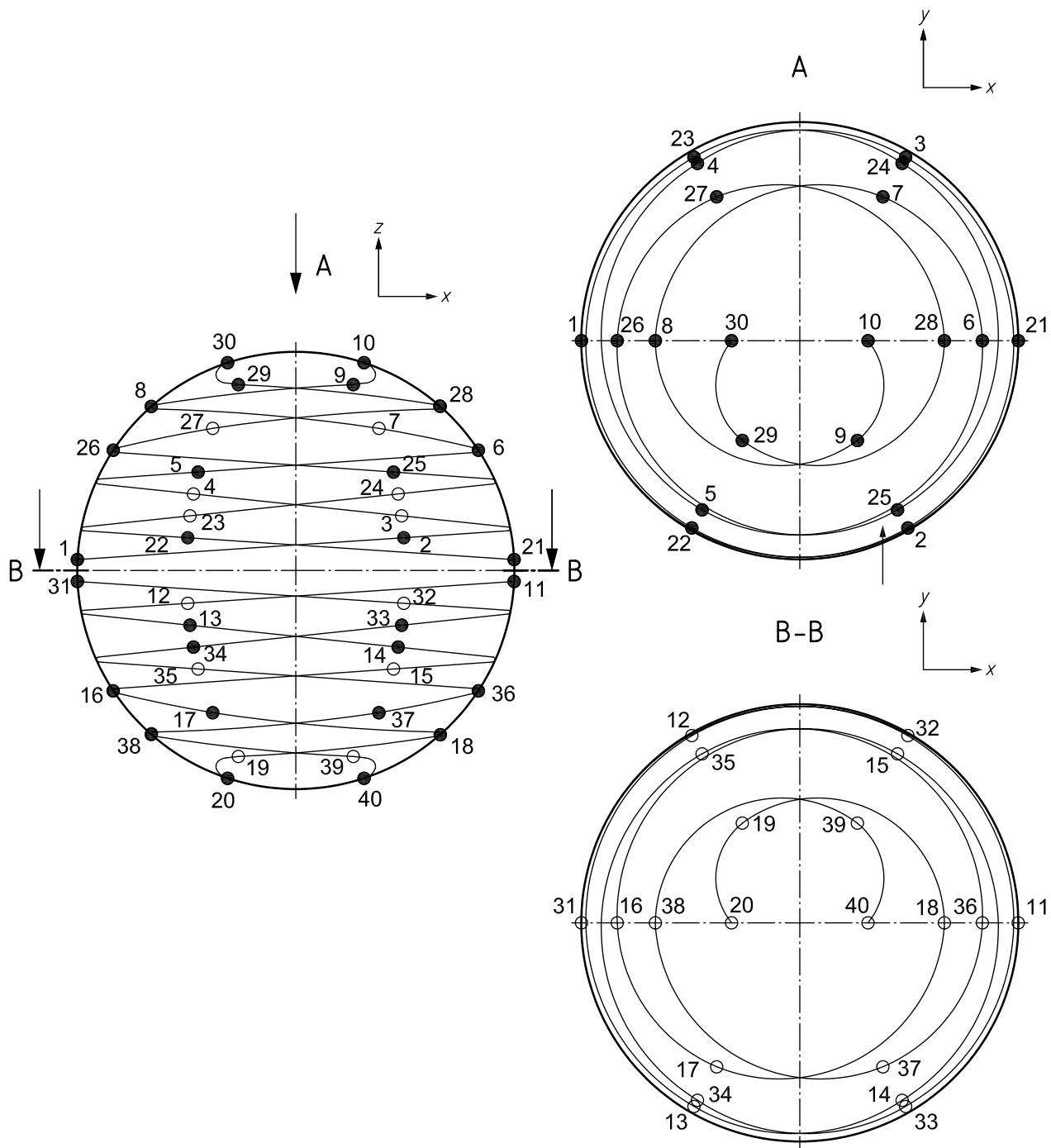

Key

- microphone positions on the facing side
- microphone positions on the remote side

Figure D.1 — Microphone positions on the spherical measurement surface

Annex E (normative)

Arrays of microphone positions on a hemispherical measurement surface in a hemi-free field

The co-ordinates of 40 positions associated with equal areas on the surface of a hemisphere of radius r , with the origin at the projection on the reflecting plane of the acoustic centre of the noise source under test, are given in Table E.1 (Reference [29]). The locations of Table E.1 positions 1 to 20 are illustrated in Figure E.1. Table E.2 provides alternate co-ordinates that may be used with a broadband omnidirectional source. The locations of Table E.2 positions 1 to 20 are illustrated in Figure E.2.

Table E.1 — Microphone positions (general case)

Position number	x/r	y/r	z/r
1	-1,000	0,000	0,025
2	0,499	-0,864	0,075
3	0,496	0,859	0,125
4	-0,492	0,853	0,175
5	-0,487	-0,844	0,225
6	0,961	0,000	0,275
7	0,000	0,947	0,320
8	-0,803	-0,464	0,375
9	0,784	-0,453	0,425
10	0,762	0,440	0,475
11	-0,737	0,426	0,525
12	0,000	-0,818	0,575
13	0,781	0,000	0,625
14	-0,369	0,639	0,675
15	-0,344	-0,596	0,725
16	0,316	-0,547	0,775
17	0,283	0,489	0,825
18	-0,484	0,000	0,875
19	0,000	-0,380	0,925
20	0,192	0,111	0,975
21	1,000	0,000	0,025
22	-0,499	0,864	0,075
23	-0,496	-0,859	0,125
24	0,492	-0,853	0,175
25	0,487	0,844	0,225
26	-0,961	0,000	0,275
27	0,000	-0,947	0,320
28	0,803	0,464	0,375
29	-0,784	0,453	0,425
30	-0,762	-0,440	0,475
31	0,737	-0,426	0,525
32	0,000	0,818	0,575
33	-0,781	0,000	0,625
34	0,369	-0,639	0,675
35	0,344	0,596	0,725
36	-0,316	0,547	0,775
37	-0,283	-0,489	0,825
38	0,484	0,000	0,875
39	0,000	0,380	0,925
40	-0,192	-0,111	0,975

Table E.2 — Microphone positions for a broadband omnidirectional source

Position number	x/r	y/r	z/r
1	-1,000	0,000	0,025
2	0,499	-0,864	0,075
3	0,496	0,859	0,125
4	-0,492	0,853	0,175
5	-0,487	-0,844	0,225
6	0,961	0,000	0,275
7	0,474	0,820	0,325
8	-0,927	0,000	0,375
9	0,453	-0,784	0,425
10	0,880	0,000	0,475
11	-0,426	0,737	0,525
12	-0,409	-0,709	0,575
13	0,390	-0,676	0,625
14	0,369	0,639	0,675
15	-0,689	0,000	0,725
16	-0,316	-0,547	0,775
17	0,565	0,000	0,825
18	-0,242	0,419	0,875
19	-0,380	0,000	0,925
20	0,111	-0,192	0,975
21	1,000	0,000	0,025
22	-0,499	0,864	0,075
23	-0,496	-0,859	0,125
24	0,492	-0,853	0,175
25	0,487	0,844	0,225
26	-0,961	0,000	0,275
27	-0,474	-0,820	0,325
28	0,927	0,000	0,375
29	-0,453	0,784	0,425
30	-0,880	0,000	0,475
31	0,426	-0,737	0,525
32	0,409	0,709	0,575
33	-0,390	0,676	0,625
34	-0,369	-0,639	0,675
35	0,689	0,000	0,725
36	0,316	0,547	0,775
37	-0,565	0,000	0,825
38	0,242	-0,419	0,875
39	0,380	0,000	0,925
40	-0,111	0,192	0,975

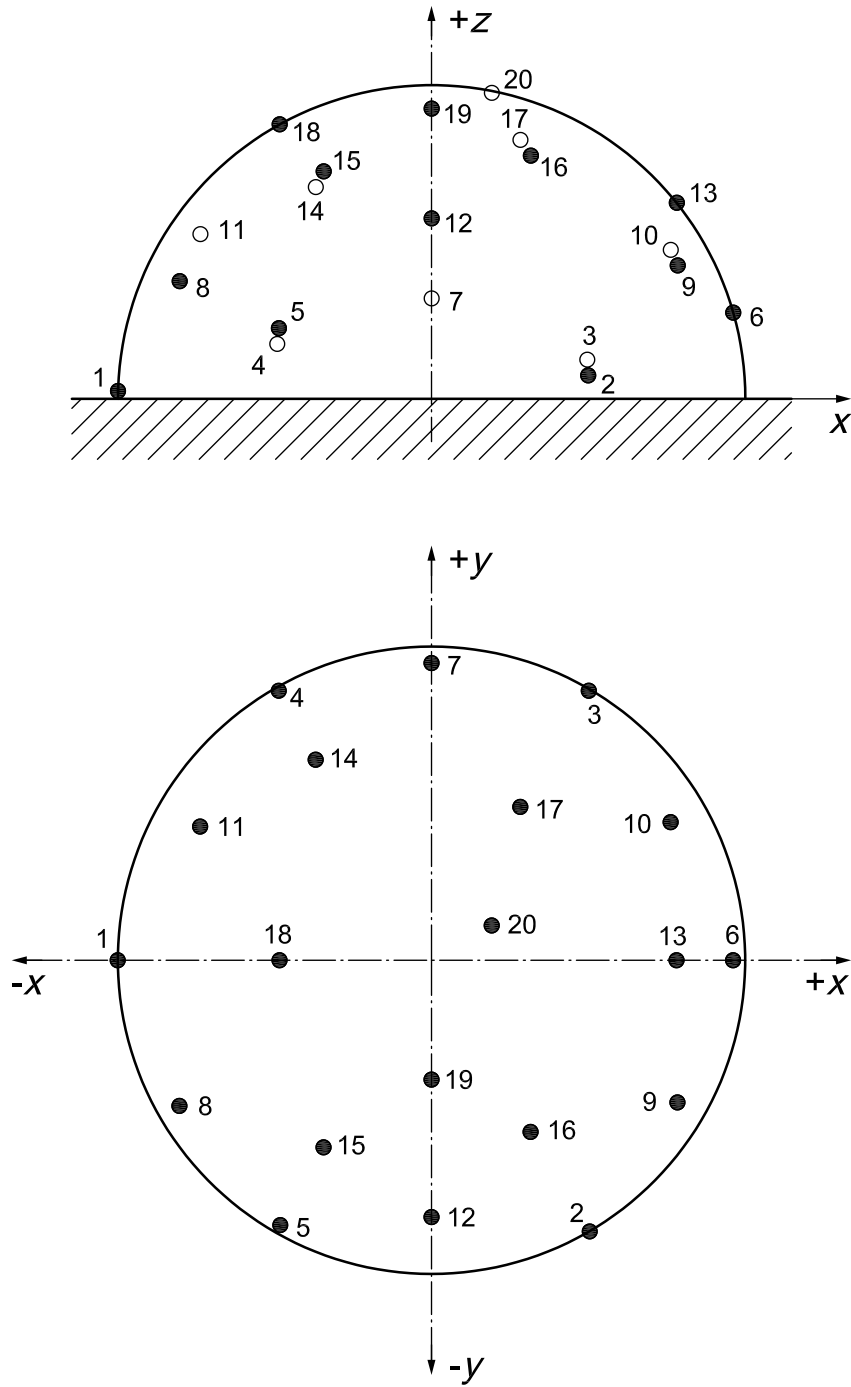

Key

- microphone positions on the facing side
- microphone positions on the remote side

Figure E.1 — Microphone positions on the hemispherical measurement surface (general case)

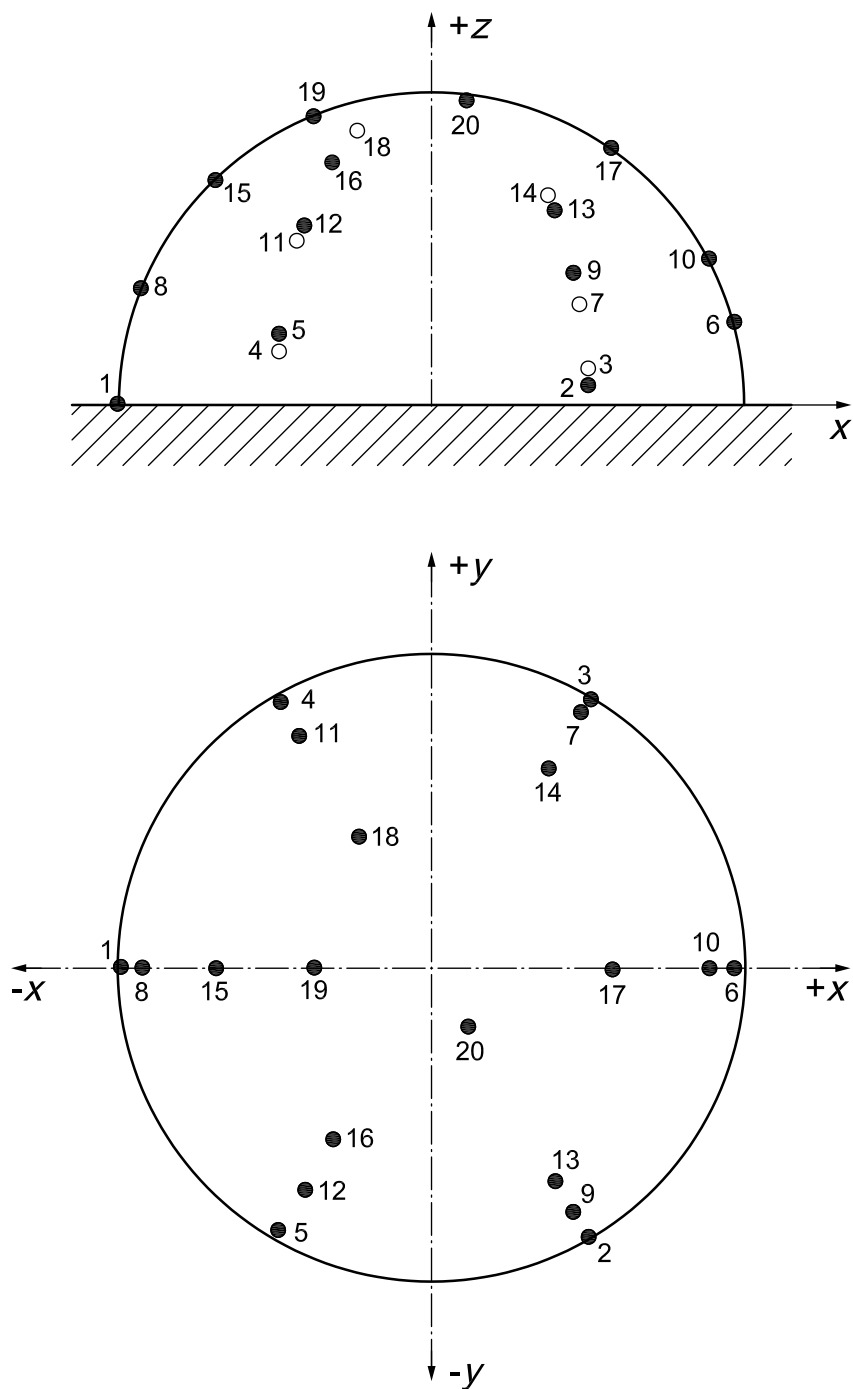

Key

- microphone positions on the facing side
- microphone positions on the remote side

Figure E.1 — Microphone positions on the hemispherical measurement surface for broadband omnidirectional sources

Annex F (normative)

Coaxial circular paths of microphones on a hemispherical measurement surface in a hemi-free field

Paths are selected, see Figure F.1, so that the annular areas of the hemisphere associated with each path are equal.

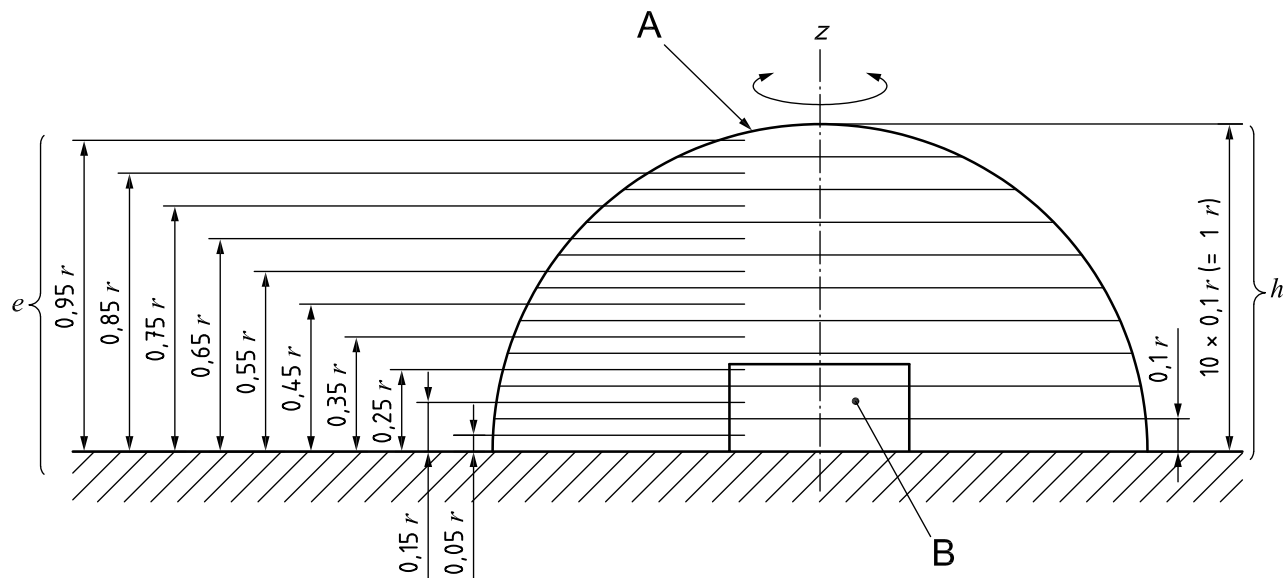

Key

- A measurement surface
- B reference box
- e elevation of microphone traverses
- h heights of corresponding areas of hemisphere
- r radius of the measurement surface
- z axis of rotation of microphone traversing mechanism

Figure F.1 — Coaxial circular paths for a moving microphone

Annex G (normative)

Meridional paths of microphones on a hemispherical measurement surface in a hemi-free field

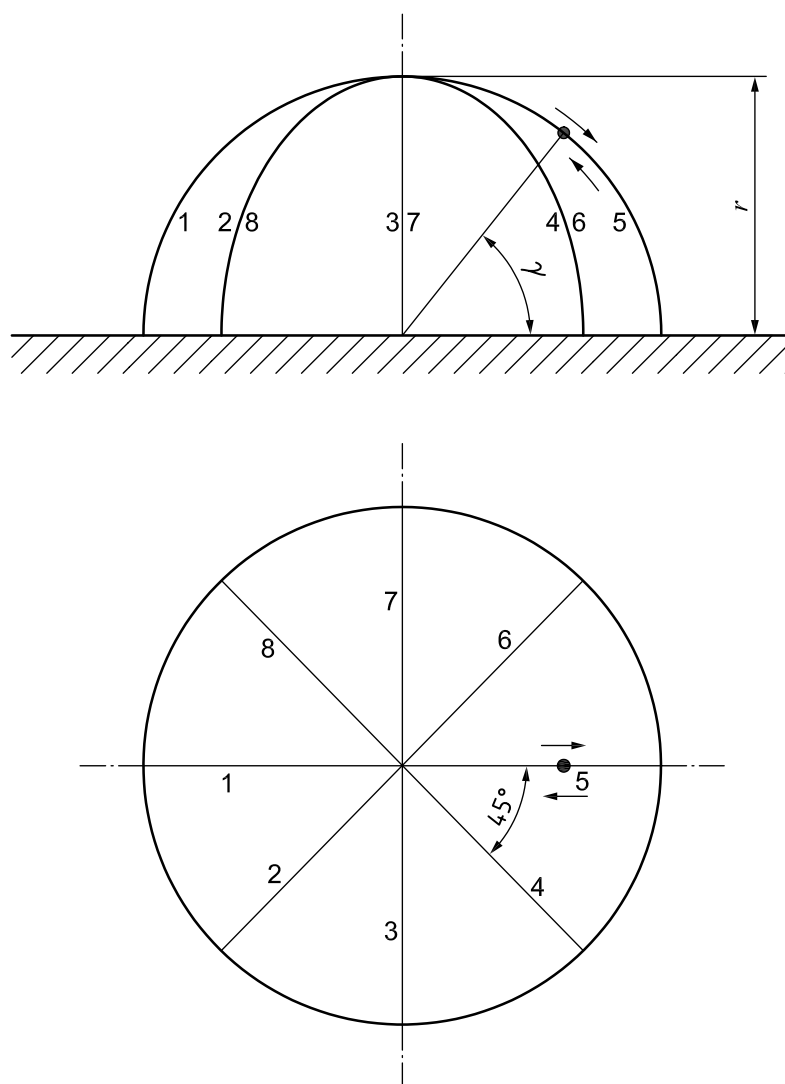

Key

1 to 8 microphone paths

Figure G.1 — Meridional paths for a moving microphone

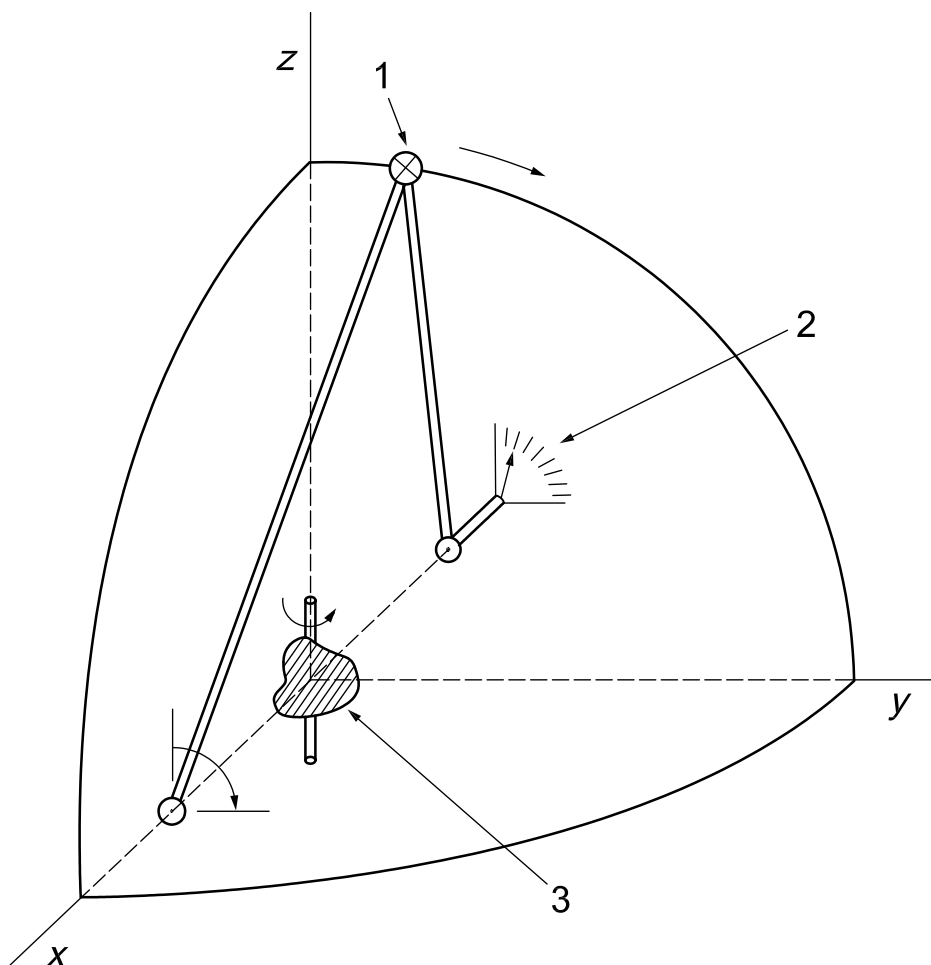

Key

- 1 travelling microphone
- 2 cosine function potentiometer for area weighting
- 3 noise source on revolving platform

Figure G.2 — Example of a mechanical system to realize a meridional path

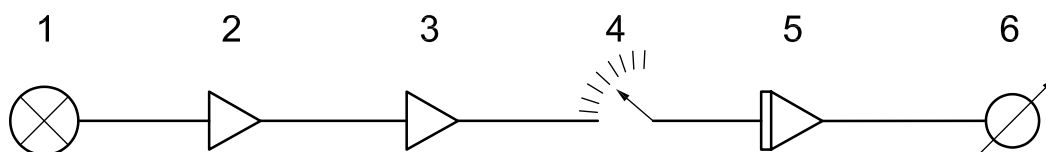

Key

- 1 microphone
- 2 amplifier and spectrum analyser
- 3 square-law amplifier
- 4 cosine potentiometer
- 5 integrating circuit
- 6 meter

Figure G.3 — Example of an electronic control circuit

Annex H
(normative)

Spiral paths of microphones on a hemispherical measurement surface in a hemi-free field

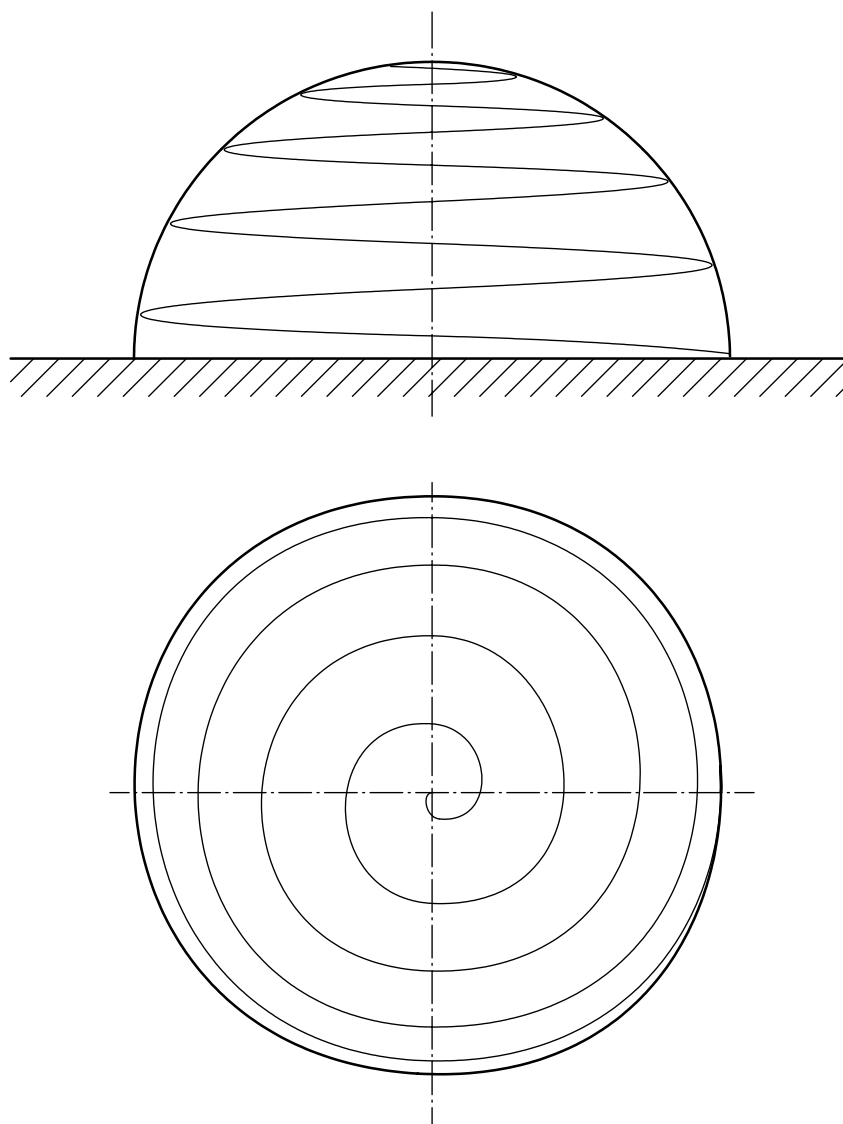

Figure H.1 — Spiral path for a moving microphone

Annex I (informative)

Guidance on the development of information on measurement uncertainty

I.1 General

The accepted format for the expression of uncertainties generally associated with methods of measurement is that given in the ISO/IEC Guide 98-3. This format incorporates a budget of uncertainty components, in which all the various sources of uncertainty are identified and from which the combined total measurement uncertainty can be obtained.

To determine the noise emission of machines and equipment, it is advisable to split up its total uncertainty into two different groups of uncertainty components:

- a) those that are intrinsic to the measurement procedure;
- b) those that result from the instability of the sound emission of the machine.

Based on knowledge current at the time of publication, this annex provides additional explanations and information by which ISO/IEC Guide 98-3 could be applied in practice for this International Standard.

This annex complements Clause 10.

I.2 Considerations on the total standard deviation, σ_{tot}

The measurement uncertainty used in this International Standard is determined by the expanded measurement uncertainty, U , which is derived directly from the total standard deviation, σ_{tot} [Equation (25)], with σ_{tot} being the approximation of the relevant $u(L_W)$ as defined in ISO/IEC Guide 98-3.

This total standard deviation, σ_{tot} , results from the two components, σ_{R0} and σ_{omc} [see Equation (24)], which are significantly different in nature.

Both quantities are assumed to be statistically independent and are determined separately.

The machinery-specific standard deviation, σ_{omc} , cannot be calculated and has to be determined by repeated measurements as described in Clause I.3. Information on the standard deviation σ_{R0} is given in Clause I.4.

NOTE The expanded measurement uncertainty, as described in this International Standard, does not include the standard deviation of production which is used in ISO 4871^[9] for the purpose of making a noise declaration for batches of machines.

I.3 Considerations on σ_{omc}

The standard deviation σ_{omc} , described in 10.2, is calculated by

$$\sigma_{\text{omc}} = \sqrt{\frac{1}{N-1} \sum_{j=1}^N (L_{p,j} - L_{pav})^2} \text{ dB} \quad (\text{I.1})$$

where

$L_{p,j}$ is the sound pressure level measured at a prescribed position and corrected for background noise for the j th repetition of the prescribed operating and mounting conditions;

L_{pav} is its arithmetic mean sound pressure level calculated for all these repetitions.

These measurements are carried out at the microphone position associated with the highest sound pressure level on the measurement surface. When measurements are averaged over the measurement surface, $L_{p,j}$, and L_{pav} are replaced in Equation (I.1) by $\overline{L_{p,j}}$ and $\overline{L_{pav}}$, respectively.

In general, the mounting and operating conditions to be used for noise emission measurements are prescribed by machinery-specific noise test codes. Otherwise, these conditions have to be defined precisely and described in the test report.

Some recommendations for defining these conditions and consequences for the expected values of σ_{omc} are given in the following.

The test conditions shall represent normal usage and conform to manufacturers' and users' recommended practice. However, even in normal usage, slightly different modes of operation, variations in material flow, and other conditions varying between different phases of operation may occur. This uncertainty covers both the uncertainty due to variation in long-term operating conditions (e.g. from day to day) and fluctuations of noise emission measurements repeated immediately after readjusting mounting and operating conditions.

Machines that stand exclusively on soft springs or on heavy concrete floors do not normally exhibit any effect of mounting. However, there can be large discrepancies between measurements on heavy concrete floors and those made *in situ*. The uncertainty due to mounting can be highest for machinery that is connected to auxiliary equipment. Hand-held machines may also cause problems. This parameter should be investigated if movement of the machine or mounts causes changes in noise. If there is a range of possible mounting conditions to be included in a single declaration, then σ_{omc} is estimated from the standard deviation of the sound levels for these mounting conditions. If there is any known effect due to mounting, recommended mounting conditions should be documented in the relevant noise test code or manufacturer's recommended practice.

In respect to the main uncertainty quantity, σ_{tot} , investigations on σ_{omc} have a higher priority compared to those on the other uncertainty components leading to σ_{R0} [see Equation (24)]. This is because σ_{omc} may be significantly larger in practice than e.g. $\sigma_{R0} = 0,5$ dB for accuracy grade 1 measurements, as given in Tables 2 or 3.

If $\sigma_{omc} > \sigma_{R0}$, the application of measurement procedures with a high accuracy, i.e. a low value of σ_{R0} makes no sense economically because this is not going to result in a lower value of the total uncertainty.

The examples in Table I.1 show that it can be superfluous to extend the measuring effort to ensure a measurement of accuracy grade 1 if the uncertainty associated with the mounting and operating conditions is large.

Furthermore, $\sigma_{omc} > \sigma_{R0}$ may create substantial misunderstandings with respect to the true relevant total standard deviation σ_{tot} , because the different grades of accuracy of this International Standard are presently defined by the value of σ_{R0} only.

Table I.1 — Examples of calculated total standard deviations, σ_{tot} , for three different cases

Standard deviation of reproducibility of the method, σ_{R0} , dB	Operating and mounting conditions		
	stable	unstable	very unstable
	Standard deviation σ_{omc}, dB		
	0,3	2	4
Total standard deviation σ_{tot}, dB			
0,5	0,6	2,1	4,0

I.4 Considerations on σ_{R0}

I.4.1 General

Upper bound values of σ_{R0} are given in Tables 2 and 3. Additionally in 10.3, the investigation of values of σ_{R0} that are relevant to individual machines or machine families in order to achieve more realistic values is recommended. These investigations shall be carried out either by measurements under reproducibility conditions as defined in ISO 5725 or by calculations using the so-called modelling approach based on Equation (27) which requires more detailed information.

If certain uncertainty components are not relevant for specific applications or are difficult to investigate, delimited definitions of σ_{R0} should be given by noise test codes both for round robin tests (see 10.3.2, fourth paragraph) and for the modelling approach analogously.

The modelling approach requires the existence of equations which allow assessment of these uncertainty components by considering measurement parameters and environmental conditions or by at least reasonable experience. Relevant well-founded data for this International Standard were not available at the time of publication. Nonetheless, the following information may give a rough impression of the relevant quantities without being definitive.

I.4.2 Contributions to the uncertainty, σ_{R0}

I.4.2.1 General

Preliminary estimations show that the sound power level of a noise source, L_W , determined in accordance with this International Standard, is a function of a number of parameters, indicated by Equation (I.2):

$$L_W = \overline{L'_{p(ST)}} + 10 \lg \frac{S}{S_0} \text{ dB} - K_1 + C_1 + C_2 + C_3 + \delta_{\text{env}} + \delta_{\text{slm}} + \delta_{\text{mic}} + \delta_{\text{angle}} + \delta_{\text{method}} + \delta_{\text{omc}} \quad (\text{I.2})$$

where

$\overline{L'_{p(ST)}}$ is the mean time-averaged sound pressure level over the measurement surface, in decibels, with the noise source under test in operation;

S is the area of the measurement surface, in square metres;

$S_0 = 1 \text{ m}^2$;

K_1 is the background noise correction, in decibels;

C_1 is the reference quantity correction, in decibels (see 9.4.4.1), to account for the different reference quantities used to calculate decibel sound pressure level and decibel sound power level, and is a function of the characteristic acoustic impedance of the air under the meteorological conditions at the time and place of the measurements;

C_2 is the acoustic radiation impedance correction, in decibels (see 9.4.4.1), to change the actual sound power relevant for the meteorological conditions at the time and place of the measurement into the sound power under reference meteorological conditions, the value shall be obtained from the appropriate noise test code, but in the absence of a noise test code, the equation for C_2 in 9.4.4.1 is valid for a monopole source, and is a mean value for other sources (References [25] [27]);

C_3 is the correction for air absorption, in decibels, at specific frequencies (Reference [28]);

δ_{env} is an input quantity to allow for any uncertainty due to reflections in the environment;

δ_{slm} is an input quantity to allow for any uncertainty in the measuring instrumentation;

δ_{mic} is an input quantity to allow for any uncertainty due to the finite number of microphone positions;

- δ_{angle} is an input quantity to allow for any difference of angle between the direction in which the sound is emitted by the source and the normal to the measurement surface;
- δ_{method} is an input quantity to allow for any uncertainty due to the applied measurement method;
- δ_{omc} is an input quantity to allow for any uncertainty due to operating and mounting conditions — this quantity is not included in the calculation of σ_{R0} [see 10.1, Equation (24)].

NOTE 1 A similar expression to that of Equation (1.2) applies to sound energy levels.

NOTE 2 The input quantities included in Equation (1.2) to allow for uncertainties are those thought to be applicable in the state of knowledge at the time of publication of this International Standard, but further research could reveal that there are others.

A probability distribution (normal, rectangular, Student-*t*, etc.) is associated with each of the input quantities. Its expectation (mean value) is the best estimate for the value of the input quantity and its standard deviation is a measure of the dispersion of values, termed uncertainty.

The uncertainty components related to mounting and operating conditions are already covered by σ_{omc} whereas σ_{R0} includes the rest of the uncertainty components.

Table I.2 provides some information about expectations current at the time of publication for the values for the components, c_i , u_i , that are necessary for calculating $\sigma_{R0} = \sqrt{\sum_i (c_i u_i)^2}$ dB.

NOTE 3 For specific families of noise sources, e. g. for a certain type of machinery, the values in this annex should be explicitly checked. Smaller values may be expected. For purposes where the sound power or sound energy levels are compared with limit values, the measured variation in δ_{angle} can be reduced when the noise test code specifies a single measurement surface shape and a measurement distance related to the source dimensions. In practice, this allows a smaller value of the total standard deviation σ_{tot} to be declared.

This calculation of σ_{R0} assumes that the individual uncertainty contributions are not correlated.

At the time of publication, the standard uncertainties from some contributions remain to be established by research.

An explanation and numerical example for the uncertainty parameters in Table I.2 are given in I.4.2.2 to I.4.2.10. Formulae to calculate uncertainties are given with examples to show the expected range of measurement uncertainties.

I.4.2.2 Sound pressure measurement repeatability

The uncertainty, $u_{L'_p(\text{ST})}$, due to measurement repeatability is the closeness of agreement between results of successive measurements carried out under the same conditions; it may be obtained from the standard deviation of repeatability, $s_{L'_p(\text{ST})}|_{\text{rep}}$, using six measurements of the decibel sound pressure levels at a single microphone position.

These measurements are made under repeatability conditions, which are defined as: same measurement procedure; same observer; same measuring instrument; same location; and repetition over a short period of time. Although not specified in ISO/IEC Guide 98-3, it is common to take down, and then set up instrumentation and equipment between trials.

The sensitivity coefficient, $c_{L'_p(\text{ST})}$, is influenced by background noise levels. It is obtained from the derivative of L_W [Equation (1.1)], with respect to $L'_p(\text{ST})$. After substitution for K_1 [Equation (11)], the sensitivity coefficient reduces to:

$$c_{L'_p(\text{ST})} = 1 + \frac{1}{10^{0,1\Delta L_p - 1}}$$

This may be further simplified to $c_{L'_p(\text{ST})} = 1 + c_{K_1}$. Measurement repeatability can be strongly influenced by averaging time. Using the same extreme scenario as for c_{K_1} results in $c_{L'_p(\text{ST})} = 1,1$. Typically, the short term repeatability is small and less than 0,1 dB, so that the contribution to uncertainty is 0,1 dB. If the averaging time

does not cover a sufficient number of machinery cycles, the total uncertainty may be unacceptably large for a standard of precision grade of accuracy. This component of uncertainty can often be made negligible with a sufficiently long averaging time consisting of an integral number of work cycles. For extremely low noise sources, reduction of background noise can reduce the sensitivity coefficient and hence total uncertainty by up to a factor of 2.

Table I.2 — Example of an uncertainty budget for determinations of σ_{R0} for sound power level and sound energy level, valid for frequencies from 500 Hz to 4 kHz, or for A-weighted measurements of a source with a relatively flat frequency spectrum

Quantity		Estimate ^a dB	Standard uncertainty ^a u_i	Probability distribution	Sensitivity coefficient ^a c_i
$\overline{L'_{p(ST)}}$	mean time-averaged sound pressure level over the measurement surface	$\overline{L'_{p(ST)}}$	$s_{L'_{p(ST)}} _{\text{rep}}$	Normal	$1 + \frac{1}{10^{0,1\Delta L_p - 1}}$
S	measurement surface area	$10 \lg \frac{S}{S_0}$	$\Delta r / \sqrt{3}$	Rectangular	$8,7/r$
K_1	background noise correction	K_1	$s_{L_{p(B)}}$	Normal	
C_1	decibel reference correction	C_1	0	Triangular	1
C_2	acoustic radiation impedance correction	C_2	0,2	Triangular	1
C_3	air absorption correction	C_3	0,1 C_3 to 0,3 C_3	Rectangular	1
δ_{env}	environmental reflections	K_2	K_2	Normal	1
δ_{slm}	sound level meter	0	0,3	Normal	1
δ_{mic}	sampling	0	v'_1 / \sqrt{n}	Normal	1
δ_{angle}	angle	0	$\frac{-1,1}{1 - 1,3(r/d_0)^2}$	Rectangular	1
δ_{method}	method	0	0	Normal	1

^a Quantities are described in the numerical example following this table.

1.4.2.3 Measurement surface area

The uncertainty due to the measurement surface area, u_{surf} , for a radius, r , is $u_{\text{surf}} = \Delta r / \sqrt{3}$. This is based on the assumption that the uncertainty has a rectangular distribution with a range of $\pm \Delta r$.

The sensitivity coefficient, c_{surf} , is obtained from the derivative of L_W with respect to r . After substitution for the surface area $S = 2\pi r^2$, the sensitivity coefficient is $c_{\text{surf}} = 8,7/r$.

In an extreme scenario, the range for Δr is 7 % of r , resulting in an uncertainty contribution, $u_{\text{surf}} c_{\text{surf}}$ of 0,4 dB. Typically, an uncertainty of 0,1 dB is achievable with more careful measurements.

I.4.2.4 Background noise correction

The uncertainty, u_{K_1} , due to background noise correction, K_1 , can be obtained from the standard deviation, $s_{L_{p(B)}}$, of the decibel values of repeated measurements of background noise at a single microphone position on the measurement surface.

The sensitivity coefficient, c_{K_1} , due to the background noise $\overline{L_{p(B)}}$ is obtained from the derivative of the sound power, L_W , with respect to $\overline{L_{p(B)}}$. After substitution for K_1 [Equation (11)], the sensitivity coefficient reduces to:

$$|c_{K_1}| = \frac{1}{10^{0,1\Delta L_p - 1}}$$

This may also be expressed as $|c_{K_1}| = 10^{-0,1(\overline{L_{p(ST)}} - \overline{L_{p(B)}})}$ (using of the corrected $\overline{L_{p(ST)}}$, instead of $\overline{L'_{p(ST)}}$).

In this example, the background noise is assumed to have a standard deviation of 3 dB, and an extreme case can occur for low noise equipment, where ΔL_p is 10 dB, resulting in a sensitivity coefficient of $c_1 = 0,1$. In this worst case, the total contribution to uncertainty is 0,3 dB. However, sources are usually much louder than the background, and the uncertainty would typically be less than 0,01 dB. This uncertainty could be reduced by lowering fluctuations in background noise. Reduction in the sensitivity coefficient is obtained by direct reduction of background noise. The influence of background noise is reduced 3 dB when the measurement surface area is reduced by a factor of 2. The uncertainty, u_{K_1} , is typically halved each time the averaging time is increased by a factor of 4.

I.4.2.5 Meteorological corrections

The decibel reference correction is associated with a negligible uncertainty, i.e. $u_{C_1} = 0$ dB. The correction has a direct effect on the measurement, so that $c_{C_1} = 1$, and the total uncertainty contribution is 0 dB.

The uncertainty, u_{C_2} , remaining after the correction for the acoustic radiation impedance [Equations (14), (15), (19) or (20)] is $u_{C_2} = 0,2$ dB. This correction has a direct effect on the measurement so that $c_{C_2} = 1$ and the total uncertainty contribution is 0,2 dB. A lower uncertainty contribution can be obtained by measuring under the reference conditions of 101,325 kPa absolute pressure (i.e. at sea level) and 23 °C. A more accurate correction may be supplied in the appropriate test code or by the manufacturer.

The contribution to the uncertainty in the sound power level, L_W , due to the correction for air absorption is $c_{C_3}u_{C_3} = 0,1C_3$, provided the attenuation coefficient $\alpha(f)$ is obtained from ISO 9613-1:1993. Otherwise, if C_3 is estimated using the approximation in 9.4.4.1, Note 2, the uncertainty contribution is $c_{C_3}u_{C_3} = 0,3C_3$. Typically this uncertainty contribution is negligible at 1 000 Hz for a 2 m radius measurement, but can rise to 0,5 dB at 10 kHz with an 8 m radius measurement. These results were obtained assuming C_3 is given by $C_3 \approx \alpha_0 r(f/10\ 000)$, where $\alpha_0 = 0,2$ dB/m and $u_{\alpha_0} = 0,1/\sqrt{3}$ dB/m (the denominator is based on an assumed rectangular distribution for α_0). The associated sensitivity coefficient is $c_{\alpha_0} = r(f/10\ 000)$. The dominant contribution to uncertainty in C_3 is due to α_0 and other components due to f and r can be ignored.

I.4.2.6 Environmental reflections

The uncertainty, u_{env} , due to the environmental reflections in a room qualified in accordance with Annex A is approximately

$$u_{env} = \frac{a}{\sqrt{3N_M}} \left(\frac{r}{r_{max}} \right)^2$$

where N_M is the number of measurement points, a is the average upper bound of the deviation of the measured sound pressure levels from theoretical levels (Table A.2 lists maximum values), r is the radius of the measurement surface and r_{max} is the distance at which a was evaluated.

In other environments, the uncertainty can be approximated by K_2 , the environmental correction from ISO 3744^[6]. Using the two surface method for specific sources in Annex B, $K_2 \approx 1,5(S_1/S_2)\delta$. In very large rooms that do not have large amounts of absorbing materials, the environmental correction can be determined from the procedures in ISO 3744^[6] where $K_2 = 10\lg[1 + 4(S/A)]$ dB, where A is the equivalent sound absorption area of the room in square metres.

Changes in environmental reflections directly affect measurement results and the sensitivity coefficient: $c_{\text{env}} = 1$. For the extreme scenario, the value of $u_{\text{env}} = 0,4$ dB, and the total uncertainty contribution is 0,4 dB. In a more typical situation, in a hemi-anechoic room at mid-frequencies where the measurement radius is 70 % of r_{max} , the total uncertainty contribution is 0,1 dB. A smaller uncertainty contribution could be obtained by reducing the measurement distance or increasing the number of measurement points.

I.4.2.7 Sound level meter

The uncertainty in the measuring instrumentation, u_{slm} for a IEC 61672-1:2002, class 1 instrument is $u_{\text{slm}} = 0,5$ dB. Uncertainties in the sound level meter directly affect measured levels, so that $c_{\text{slm}} = 1$, and the total uncertainty contribution is normally considered to be 0,5 dB. However, practical experience in anechoic rooms in national laboratories suggests this difference is closer to 0,3 dB. Additional details regarding parameters affecting the uncertainty of sound level meters can be found in IEC 61672-1.

I.4.2.8 Sampling

The uncertainty due to the finite number of microphone positions is

$$u_{\text{mic}} = \frac{u_{L'_p(\text{ST})}}{\sqrt{N_M}} = \frac{V_1}{\sqrt{N_M}}$$

where

V_1 is the surface sound pressure level non-uniformity index (see 3.24);

N_M is the number of microphone positions.

Sampling directly affects the total uncertainty, so $c_{\text{mic}} = 1$. For the extreme scenario, with 20 measurement points, this standard limits the range of measured values to 10 dB or less, so that the maximum value of $u_{\text{mic}} = 1,1$ dB. Considering the relatively small sources measured in anechoic rooms, a typical uncertainty contribution of 0,25 dB is more likely. The uncertainty contribution can be reduced by increasing the number of measurement positions or increasing the measurement distance.

I.4.2.9 Angle

The uncertainty due to the incident angle of the sound energy is u_{angle} . The use of sound pressure to approximate the sound intensity leads to an overestimate of the sound power. For a hemispherical measurement surface, this overestimate depends on the angle and impedance of the incident sound, (i.e. the intensity and coherence of sound produced by different parts of the source). The overestimate ranges between 0 dB and $\{-2/[1 - 1,3(r/d_0)^2]\}$ dB, where d_0 is the characteristic dimension of the noise source. The largest overestimate can occur when sound is produced from localized position(s) near the top corner(s) of the source. For a hemispherical measurement surface in a free field above a reflecting plane, the standard deviation is:

$$u_{\text{angle}} = \frac{-1,1}{1 - 1,3(r/d_0)^2} \text{ dB}$$

In individual frequency bands, the uncertainty u_{angle} is affected by the microphone directivity. Using a 1/2" microphone below 4 kHz, the above formula is appropriate. At higher frequencies, this uncertainty is gradually reduced and the $\pm 30^\circ$ directional response starts to approximate that of an intensity probe. At 10 kHz, $u_{\text{angle}} = 0$ dB, and at higher frequencies the microphone shall be pointed at the source of sound radiation to avoid underestimating levels.

The sensitivity coefficient c_{angle} in ISO 3744^[6] is a function of the environmental correction, K_2 , and is approximately 1 for $K_2 < 0,5$ dB (see u_{env}). In 8.1, the smallest r is $2d_0$, so the worst case $u_{\text{angle}} = 0,26$ dB. In many cases, the measurement radius is larger than the minimum, so the typical total contribution to uncertainty $u_{\text{angle}} c_{\text{angle}} = 0,1$ dB. This uncertainty contribution can be reduced using a larger measurement radius or by correction for the bias component of u_{angle} . However, the magnitude of the bias correction is unique to each source and shall be specified in a noise test code.

I.4.2.10 Measurement method

Measurement in a free field is the standard reference for acoustical measurements so that the value of uncertainty due to the measurement method is $u_{\text{method}} = 0$ dB, and the uncertainty contribution, $u_{\text{method}} c_{\text{method}}$, is 0 dB.

I.4.2.11 Typical value for σ_{R0}

Using the typical values from the preceding and assuming negligible correlation between the input quantities, σ_{R0} based on Equation (I.2) is

$$\begin{aligned}\sigma_{R0} &= \sqrt{0,1^2 + 0,1^2 + 0,01^2 + 0^2 + 0,2^2 + 0^2 + 0,1^2 + 0,3^2 + 0,25^2 + 0,1^2 + 0^2} \text{ dB} \\ &= 0,48 \text{ dB}\end{aligned}$$

I.4.2.12 Measurement in frequency bands

Systematic uncertainties which are correlated in all frequency bands have the same uncertainty in individual bands and in the A-weighted total. Examples are u_{surf} , due to measurement distance, or δ_{angle} , due to measurement angle. Other parameters in Table I.1, such as u_{C_2} and δ_{slm} , are often correlated.

The A-weighted uncertainty is lower than the uncertainty in individual frequency bands when there is no correlation between uncertainties in each frequency band. For example, the uncertainty due to the bandwidth time product is reduced by summation of multiple bands. Other examples include $u_{L'_p(\text{ST})}$, u_{K_1} , δ_{env} and δ_{mic} .

The sensitivity coefficient, c_{band} , associated with the uncertainty in an individual frequency band, u_{band} , is:

$$c_{\text{band}} = \frac{10^{0,1L_{\text{band}}}}{10^{0,1L_A}}$$

where

L_{band} is the level in the associated frequency band;

L_A is the overall A-weighted level.

The total uncertainty in the A-weighted level is given by:

$$u_A = \sqrt{\sum (c_{\text{band}} u_{\text{band}})^2}$$

where u_{band} is the measured uncertainty in the associated frequency band.

Comparison of A-weighted and frequency band uncertainties can be evidence of correlation. For example, starting with the assumption that the standard deviations of reproducibility, σ_{R0} , in Table 2 are uncorrelated, a spectrum flat from 100 Hz to 10 kHz has an A-weighted σ_{R0} of only 0,27 dB. This is 0,23 dB less than the value in Table 2, which suggests there is a small 0,4 dB uncertainty component correlated across frequency bands.

I.5 Combined standard uncertainty

In the case of negligible correlation between the input quantities, the combined standard uncertainty of the determination of the sound power level, $u(L_W)$, in decibels, is given by Equation (I.3):

$$u(L_W) \approx \sigma_{\text{tot}} = \sqrt{\sigma_{R0}^2 + \sigma_{\text{omc}}^2} = \sqrt{\sum_i (c_i u_i)^2 + \sigma_{\text{omc}}^2} \quad (\text{I.3})$$

I.6 Measurement uncertainty based on reproducibility data

In the absence of data for uncertainty contributions and possible correlations between input quantities, values for the standard deviation of reproducibility as given in Clause 10 may be used as an estimate of the combined standard uncertainty of determinations of sound power levels, $u(L_W)$. A value may then be selected for the coverage factor, k , and the product $k\sigma_{\text{tot}}$ yields an estimate of the expanded measurement uncertainty, U , with the chosen coverage probability. By convention, a coverage probability of 95 % is usually chosen, and assuming a normal distribution, the associated two-sided coverage factor is 2. To avoid misinterpretation, the coverage probability should be stated in test reports, together with the expanded measurement uncertainty.

I.7 Example of an uncertainty budget for a reference sound source in a national laboratory

I.7.1 General

The uncertainties given in this clause are assumed to be valid for frequencies from 500 Hz to 4 kHz or for an A-weighted sound power determination.

I.7.2 Contributions to the uncertainty, σ_{omc}

Solid level floors and a clear unimpeded space around the source make the uncertainty due to mounting conditions negligible for a reference sound source. After applying the manufacturer-supplied corrections for operating conditions, such as temperature, pressure and rotational speed, $\sigma_{\text{omc}} = 0,04$ dB.

I.7.3 Contributions to the uncertainty, σ_{R0}

There follows a list of uncertainties and explanations associated with σ_{R0} .

$u_{L'_p(\text{ST})} c_{L'_p(\text{ST})}$	= 0,10 dB; source stability and the relatively ideal measurement environment make the effect of this uncertainty parameter small, typically 0,10 dB.
$u_{\text{surf}} c_{\text{surf}}$	= 0,05 dB; a typical measurement radius would be 2 m, and measurements can be made within ± 20 mm. Thus $u_{\text{surf}} = 0,012$ m and $c_{\text{surf}} = 4,35$ dB/m.
$u_{K_1} c_{K_1}$	= 0,00 dB; a reference sound source produces an A-weighted sound power level of 90 dB, which is much larger than conceivable background noise levels. This makes the sensitivity coefficient c_{K_1} vanishingly small and this uncertainty contribution is negligible.
$u_{C_1} c_{C_1}$	= 0 dB; uncertainties in the decibel reference correction are negligible.
$u_{C_2} c_{C_2}$	= 0 dB; uncertainties in the manufacturer-supplied correction for meteorological conditions are accounted for in the uncertainty for operating conditions. The meteorological corrections in this International Standard are not applicable so this uncertainty is identically zero.
$u_{C_3} c_{C_3}$	= 0 dB; uncertainties due to atmospheric absorption are assumed negligible after correction.

$u_{env}^{c_{env}}$	= 0,09 dB; assuming a qualified distance, r_{max} , of 3 m, and a typical deviation, $a = 1,5$ dB, results in the value of $u_{env} = 0,09$ dB, and a total uncertainty contribution of 0,09 dB.
$u_{slm}^{c_{slm}}$	= 0,25 dB; for a reference sound source, the environmental conditions and measurement conditions under which it is characterized are as close to ideal as possible. National laboratories also use similar equipment and procedures. These factors reduce reproducibility differences in the use of sound level meters. Additional details regarding uncertainty of sound level meters are found in IEC 61672-1.
$u_{mic}^{c_{mic}}$	= 0,08 dB; due to destructive interference from source and image individual one-third octave bands have notches with a depth of up to 10 dB. After A weighting, these effects are reduced, but the standard deviation over the 20 measurement points is approximately 1 dB, suggesting $u_{mic} = 0,22$ dB. Incrementally increasing the number of measurement points up to 150 has little effect on these values so, based on the uncertainty calculated for 150 points, it can be assumed that $u_{mic} = 0,08$ dB when using 20 or more measurement points.
$u_{angle}^{c_{angle}}$	= 0,02 dB; assuming a measurement radius of 2 m and characteristic reference source dimension of 0,3 m, then $u_{angle} = 0,02$ dB.
$u_{method}^{c_{method}}$	= 0 dB; measurement in a free field is the standard reference for acoustical measurements.

Using the values suggested in the preceding and assuming negligible correlation between the input quantities, the standard deviation of reproducibility of the method is

$$\begin{aligned}\sigma_{R0} &= \sqrt{0,10^2 + 0,05^2 + 0,00^2 + 0^2 + 0^2 + 0^2 + 0,09^2 + 0,25^2 + 0,08^2 + 0,02^2 + 0^2} \text{ dB} \\ &= 0,30 \text{ dB}\end{aligned}$$

1.7.4 Combined standard uncertainty

The combined standard uncertainty of the determination of the sound power level, $u(L_W)$, in accordance with Equation (1.3) is:

$$\begin{aligned}u(L_W) &\approx \sigma_{tot} = \sqrt{\sigma_{R0}^2 + \sigma_{omc}^2} \\ &= 0,30 \text{ dB}\end{aligned}$$

The expanded uncertainty is twice the combined standard uncertainty, i.e. 0,6 dB for a coverage probability of 95 % and assuming a normal distribution.

Bibliography

- [1] ISO 140-3, *Acoustics — Measurement of sound insulation in buildings and of building elements — Part 3: Laboratory measurements of airborne sound insulation of building elements*
- [2] ISO 3740, *Acoustics — Determination of sound power levels of noise sources — Guidelines for the use of basic standards*
- [3] ISO 3741:2010, *Acoustics — Determination of sound power levels and sound energy levels of noise sources using sound pressure — Precision methods for reverberation test rooms*
- [4] ISO 3743-1, *Acoustics — Determination of sound power levels and sound energy levels of noise sources using sound pressure — Engineering methods for small movable sources reverberant fields — Part 1: Comparison method for a hard-walled test room*
- [5] ISO 3743-2, *Acoustics — Determination of sound power levels of noise sources using sound pressure — Engineering methods for small, movable sources reverberant fields — Part 2: Methods for special reverberation test rooms*
- [6] ISO 3744, *Acoustics — Determination of sound power levels and sound energy levels of noise sources using sound pressure — Engineering methods for an essentially free field over a reflecting plane*
- [7] ISO 3746, *Acoustics — Determination of sound power levels and sound energy levels of noise sources using sound pressure — Survey method using an enveloping measurement surface over a reflecting plane*
- [8] ISO 3747, *Acoustics — Determination of sound power levels and sound energy levels of noise sources using sound pressure — Engineering/survey methods for use in situ in a reverberant environment*
- [9] ISO 4871, *Acoustics — Declaration and verification of noise emission values of machinery and equipment*
- [10] ISO 6926, *Acoustics — Requirements for the performance and calibration of reference sound sources used for the determination of sound power levels*
- [11] ISO 7574-1, *Acoustics — Statistical methods for determining and verifying stated noise emission values of machinery and equipment — Part 1: General considerations and definitions*
- [12] ISO 7574-2, *Acoustics — Statistical methods for determining and verifying stated noise emission values of machinery and equipment — Part 2: Methods for stated values for individual machines*
- [13] ISO 7574-3, *Acoustics — Statistical methods for determining and verifying stated noise emission values of machinery and equipment — Part 3: Simple (transition) method for stated values for batches of machines*
- [14] ISO 7574-4, *Acoustics — Statistical methods for determining and verifying stated noise emission values of machinery and equipment — Part 4: Methods for stated values for batches of machines*
- [15] ISO 9614-1, *Acoustics — Determination of sound power levels of noise sources using sound intensity — Part 1: Measurement at discrete points*
- [16] ISO 9614-2, *Acoustics — Determination of sound power levels of noise sources using sound intensity — Part 2: Measurement by scanning*
- [17] ISO 9614-3, *Acoustics — Determination of sound power levels of noise sources using sound intensity — Part 3: Precision method for measurement by scanning*
- [18] ISO 11201, *Acoustics — Noise emitted by machinery and equipment — Determination of emission sound pressure levels at a work station and at other specified positions in an essentially free field over a reflecting plane with negligible environmental corrections*
- [19] ISO 11690-1, *Acoustics — Recommended practice for the design of low-noise workplaces containing machinery — Part 1: Noise control strategies*

- [20] ISO/TR 25417:2007, *Acoustics — Definitions of basic quantities and terms*
- [21] ISO 26101, *Acoustics — Test methods for the qualification of free-field environments*
- [22] ISO 80000-8:2007, *Quantities and units — Part 8: Acoustics*
- [23] NOBILE, M.A., DONALD, B., SHAW, J.A. The cylindrical microphone array: A proposal for use in international standards for sound power level measurements. In: *Proceedings Noise-Con 2000*, Newport Beach, USA, INCE Conference Proceedings, 2000-12-03, **108**, pp. 201-206
- [24] WITTSTOCK, V. On the uncertainty of meteorological corrections in sound power determination. In: *Proceedings Inter-Noise 2004*, Prague, Czech Republic, INCE Conference Proceedings, 2004-08-22, **207**, pp. 1675-1680
- [25] DAVIES, R.S. Equation for the determination of the density of moist air. *Metrologia* 1992, **29**, pp. 67-70
- [26] CRAMER, O. The variation of the specific heat ratio and the speed of sound in air with temperature, humidity and CO₂ concentration. *J. Acoust. Soc. Am.* 1993, **93**, pp. 2510-2516
- [27] HÜBNER, G. Accuracy consideration on the meteorological correction for a normalized sound power level. In: *Proceedings Inter-Noise 2000*, Nice, France, INCE Conference Proceedings, 2000-08-27, **204**, pp. 1907-1912
- [28] JOPPA, P.D., SUTHERLAND, L.C., ZUCKERWAR, A.J. Representative frequency approach to the effect of bandpass filters on evaluation of sound attenuation by the atmosphere. *Noise Control Eng. J.* 1996, **44**, pp. 261-273
- [29] SUZUKI, H., NAKAMURA, M., TICHY, J. An accuracy evaluation of the sound power measurement by the use of the sound intensity and the sound pressure methods. *Acoust. Sci. Technol.* 2007, **28**, pp. 319-327
- [30] MALING, G.C. Jr., WISE, R.E., NOBILE, M.A. Qualification of hemi-anechoic rooms for noise emission measurements. In: *Proceedings Inter-Noise 1990*, Gothenburg, Sweden, INCE Conference Proceedings, 1990-08-13, **223**, pp. 685-690
- [31] CHADA, A., RISTROPH, E., WINKER, D.F. Effect of source directionality on deviations from inverse square law in a hemi-anechoic chamber typically used for product noise emission testing. In: *Proceedings Noise-Con 2007*, Reno, USA, INCE Conference Proceedings, 2007-10-22, **116**, pp. 596-606
- [32] BERANEK, L.L. *Acoustics*. New York, NY: American Institute of Physics, 1986. 491 p.
- [33] BETHKE, C., WITTSTOCK, V. Technical aspects of the qualification of free-field environments. In: *Proceedings NAG/DAGA 2009*, International Conference on Acoustics, Rotterdam, 2009-03-23/26
- [34] CUNEFARE, K.A., BIESEL, V.B., TRAN, J., RYE, R., GRAF, A., HOLDHUSEN, M., ALBANESE, A.M. Anechoic chamber qualification: traverse method, inverse square law analysis method, and nature of test signal. *J. Acoust. Soc. Am.* 2003, **113**, pp. 881–892

British Standards Institution (BSI)

BSI is the national body responsible for preparing British Standards and other standards-related publications, information and services.

BSI is incorporated by Royal Charter. British Standards and other standardization products are published by BSI Standards Limited.

About us

We bring together business, industry, government, consumers, innovators and others to shape their combined experience and expertise into standards-based solutions.

The knowledge embodied in our standards has been carefully assembled in a dependable format and refined through our open consultation process. Organizations of all sizes and across all sectors choose standards to help them achieve their goals.

Information on standards

We can provide you with the knowledge that your organization needs to succeed. Find out more about British Standards by visiting our website at bsigroup.com/standards or contacting our Customer Services team or Knowledge Centre.

Buying standards

You can buy and download PDF versions of BSI publications, including British and adopted European and international standards, through our website at bsigroup.com/shop, where hard copies can also be purchased.

If you need international and foreign standards from other Standards Development Organizations, hard copies can be ordered from our Customer Services team.

Subscriptions

Our range of subscription services are designed to make using standards easier for you. For further information on our subscription products go to bsigroup.com/subscriptions.

With **British Standards Online (BSOL)** you'll have instant access to over 55,000 British and adopted European and international standards from your desktop. It's available 24/7 and is refreshed daily so you'll always be up to date.

You can keep in touch with standards developments and receive substantial discounts on the purchase price of standards, both in single copy and subscription format, by becoming a **BSI Subscribing Member**.

PLUS is an updating service exclusive to BSI Subscribing Members. You will automatically receive the latest hard copy of your standards when they're revised or replaced.

To find out more about becoming a BSI Subscribing Member and the benefits of membership, please visit bsigroup.com/shop.

With a **Multi-User Network Licence (MUNL)** you are able to host standards publications on your intranet. Licences can cover as few or as many users as you wish. With updates supplied as soon as they're available, you can be sure your documentation is current. For further information, email bsmusales@bsigroup.com.

BSI Group Headquarters

389 Chiswick High Road London W4 4AL UK

Revisions

Our British Standards and other publications are updated by amendment or revision.

We continually improve the quality of our products and services to benefit your business. If you find an inaccuracy or ambiguity within a British Standard or other BSI publication please inform the Knowledge Centre.

Copyright

All the data, software and documentation set out in all British Standards and other BSI publications are the property of and copyrighted by BSI, or some person or entity that owns copyright in the information used (such as the international standardization bodies) and has formally licensed such information to BSI for commercial publication and use. Except as permitted under the Copyright, Designs and Patents Act 1988 no extract may be reproduced, stored in a retrieval system or transmitted in any form or by any means – electronic, photocopying, recording or otherwise – without prior written permission from BSI. Details and advice can be obtained from the Copyright & Licensing Department.

Useful Contacts:

Customer Services

Tel: +44 845 086 9001

Email (orders): orders@bsigroup.com

Email (enquiries): cservices@bsigroup.com

Subscriptions

Tel: +44 845 086 9001

Email: subscriptions@bsigroup.com

Knowledge Centre

Tel: +44 20 8996 7004

Email: knowledgecentre@bsigroup.com

Copyright & Licensing

Tel: +44 20 8996 7070

Email: copyright@bsigroup.com



...making excellence a habit.™