

BS EN ISO 3691-1:2015

Incorporating corrigendum June 2016



BSI Standards Publication

Industrial trucks — Safety requirements and verification

Part 1: Self-propelled industrial trucks, other than driverless trucks, variable-reach trucks and burden-carrier trucks (ISO 3691-1:2011, including Cor 1:2013)

National foreword

This British Standard is the UK implementation of EN ISO 3691-1:2015, incorporating corrigendum June 2016. It is identical to ISO 3691-1:2011, incorporating corrigendum August 2013. It supersedes BS EN ISO 3691-1:2012 which is withdrawn.

The UK participation in its preparation was entrusted to Technical Committee MHE/7, Industrial trucks.

A list of organizations represented on this committee can be obtained on request to its secretary.

This publication does not purport to include all the necessary provisions of a contract. Users are responsible for its correct application.

© The British Standards Institution 2016.
Published by BSI Standards Limited 2016

ISBN 978 0 580 93556 5

ICS 53.060

Compliance with a British Standard cannot confer immunity from legal obligations.

This British Standard was published under the authority of the Standards Policy and Strategy Committee on 31 May 2016.

Amendments/corrigenda issued since publication

Date	Text affected
31 July 2016	Implementation of CEN corrigendum June 2016: European foreword updated

English Version

**Industrial trucks - Safety requirements and verification - Part 1:
Self-propelled industrial trucks, other than driverless trucks,
variable-reach trucks and burden-carrier trucks (ISO 3691-
1:2011, including Cor 1:2013)**

Chariots de manutention - Exigences de sécurité et vérification - Partie 1: Chariots de manutention automoteurs, autres que les chariots sans conducteurs, les chariots à portée variable et les chariots transporteurs de charges (ISO 3691-1:2011, y compris Cor 1:2013)

Sicherheit von Flurförderzeugen - Sicherheitsanforderungen und Verifizierung - Teil 1: Motorkraftbetriebene Flurförderzeuge mit Ausnahme von fahrerlosen Flurförderzeugen, Staplern mit veränderlicher Reichweite und Lastentransportfahrzeugen (ISO 3691-1:2011, einschließlich Cor 1:2013)

This European Standard was approved by CEN on 1 June 2015.

CEN members are bound to comply with the CEN/CENELEC Internal Regulations which stipulate the conditions for giving this European Standard the status of a national standard without any alteration. Up-to-date lists and bibliographical references concerning such national standards may be obtained on application to the CEN-CENELEC Management Centre or to any CEN member.

This European Standard exists in three official versions (English, French, German). A version in any other language made by translation under the responsibility of a CEN member into its own language and notified to the CEN-CENELEC Management Centre has the same status as the official versions.

CEN members are the national standards bodies of Austria, Belgium, Bulgaria, Croatia, Cyprus, Czech Republic, Denmark, Estonia, Finland, Former Yugoslav Republic of Macedonia, France, Germany, Greece, Hungary, Iceland, Ireland, Italy, Latvia, Lithuania, Luxembourg, Malta, Netherlands, Norway, Poland, Portugal, Romania, Slovakia, Slovenia, Spain, Sweden, Switzerland, Turkey and United Kingdom.



EUROPEAN COMMITTEE FOR STANDARDIZATION
COMITÉ EUROPÉEN DE NORMALISATION
EUROPÄISCHES KOMITEE FÜR NORMUNG

CEN-CENELEC Management Centre: Avenue Marnix 17, B-1000 Brussels

European foreword

The text of ISO 3691-1:2011 including Cor 1:2013 has been prepared by Technical Committee ISO/TC 110 “Industrial trucks” of the International Organization for Standardization (ISO) and has been taken over as EN ISO 3691-1:2015 by Technical Committee CEN/TC 150 “Industrial Trucks - Safety” the secretariat of which is held by BSI.

This European Standard shall be given the status of a national standard, either by publication of an identical text or by endorsement, at the latest by January 2016, and conflicting national standards shall be withdrawn at the latest by January 2016.

Attention is drawn to the possibility that some of the elements of this document may be the subject of patent rights. CEN [and/or CENELEC] shall not be held responsible for identifying any or all such patent rights.

For the purposes of global relevance, the requirements of all clauses referring to ISO/TS 3691-7 have been transferred and published as European Standard EN 16307-1, *Industrial trucks — Safety requirements and verification — Part 1: Supplementary requirements for self-propelled industrial trucks, other than driverless trucks, variable-reach trucks and burden-carrier trucks*.

This document supersedes EN ISO 3691-1:2012.

This document has been prepared under a mandate given to CEN by the European Commission and the European Free Trade Association, and supports essential requirements of 2006/42/EC.

For relationship with EU Directive, see informative Annex ZA, which is an integral part of this document.

According to the CEN-CENELEC Internal Regulations, the national standards organizations of the following countries are bound to implement this European Standard: Austria, Belgium, Bulgaria, Croatia, Cyprus, Czech Republic, Denmark, Estonia, Finland, Former Yugoslav Republic of Macedonia, France, Germany, Greece, Hungary, Iceland, Ireland, Italy, Latvia, Lithuania, Luxembourg, Malta, Netherlands, Norway, Poland, Portugal, Romania, Slovakia, Slovenia, Spain, Sweden, Switzerland, Turkey and the United Kingdom.

Endorsement notice

The text of ISO 3691-1:2011 including Cor 1:2013 has been approved by CEN as EN ISO 3691-1:2015 without any modification.

Annex ZA (informative)

Relationship between this European Standard and the Essential Requirements of EU Directive 2006/42/EC

This European Standard has been prepared under a mandate given to CEN by the European Commission and the European Free Trade Association to provide a means of conforming to Essential Requirements of the New Approach Directive 2006/42/EC on machinery.

Once this standard is cited in the Official Journal of the European Union under that Directive and has been implemented as a national standard in at least one Member State, compliance with the clauses of this standard, except clause 6.2.7 and with the exclusion of all references to ISO/TS 3691-8 confers, within the limits of the scope of this standard, a presumption of conformity with the relevant Essential Requirements of that Directive and associated EFTA regulations.

WARNING: Other requirements and other EU Directives may be applicable to the products falling within the scope of this standard.

Contents

Page

Introduction.....	v
1 Scope.....	1
2 Normative references.....	2
3 Terms and definitions.....	4
4 Safety requirements and/or protective measures.....	6
4.1 General.....	6
4.2 Starting/moving.....	7
4.3 Brakes.....	8
4.4 Manual control actuators.....	9
4.5 Power systems and accessories.....	13
4.6 Systems for lifting and tilting.....	16
4.7 Operator positions.....	19
4.8 Stability.....	25
4.9 Protective devices.....	26
4.10 Visibility and lighting.....	28
4.11 Environmental conditions.....	28
4.12 Devices for towing.....	30
5 Verification of safety requirements and/or protective measures.....	30
5.1 General.....	30
5.2 Structural tests.....	30
5.3 Functional verification.....	31
6 Information for use.....	31
6.1 General.....	31
6.2 Instruction handbook.....	31
6.3 Marking.....	35
Annex A (normative) Determination of driving direction and rated capacity.....	38
Annex B (informative) List of significant hazards.....	41

Introduction

General

This document is a type-C standard as stated in ISO 12100.

The machines concerned and the extent to which hazards, hazardous situations or hazardous events are covered are indicated in the Scope of this document.

When requirements of this type-C standard are different from those which are stated in type-A or B standards, the requirements of this type-C standard take precedence over the requirements of the other standards for machines that have been designed and built according to the requirements of this type-C standard.

The ISO 3691 series of standards covers safety requirements and their verification for industrial trucks as defined in ISO 5053.

Structure

An important step forward in the work on the ISO 3691 series of standards was the agreement to issue a new structure of International Standards for industrial trucks having on one side basic standards for all kinds of trucks (see Foreword) and on the other side independent standards to cover the respective specific functions of industrial trucks, e.g. visibility, noise, vibration, electrical requirements, etc.

Assessment of hazards

The product needs to be designed in such a way that it is fit for its purpose or function and can be adjusted and maintained without putting persons at risk when used under the conditions foreseen by the manufacturer.

In order to properly design a product and to cover all specific safety requirements, the manufacturer will have to identify the hazards that apply to his product and carry out a risk assessment. The manufacturer will then need to design and construct the product taking this assessment into account.

The aim of this procedure is to eliminate the risk of accidents throughout the foreseeable lifetime of the machinery, including the phases of assembling and dismantling where risks of accidents could also arise from foreseeable abnormal situations.

In selecting the most appropriate methods, the manufacturer will need to apply the following principles, in the order given here:

- a) eliminate or reduce risks as far as possible by design (inherently safe machinery design and construction);
- b) take the necessary protective measures in relation to risks that cannot be eliminated by design;
- c) inform users of any shortcoming of the protective measures adopted;
- d) indicate whether any particular training is required;
- e) specify any need to provide personal protection equipment;
- f) refer to the appropriate user's document for proper operating instructions.

Industrial trucks need to be designed to prevent foreseeable misuse wherever possible, if such would engender risk. In other cases, the instructions will need to draw the user's attention to ways shown by experience in which the machinery ought not be used.

This part of ISO 3691 does not repeat all the technical rules which are state-of-the art and which are applicable to the material used to construct the industrial truck. Reference will also need to be made to ISO 12100.

Legislative situation/Vienna Agreement

From the very beginning, the task of the working group was to revise ISO 3691:1980 and establish worldwide basic standards to comply with the major legislative regulations in, for example, the EU, Japan, Australia and North America.

Every effort was made to develop a globally relevant International Standard. That goal was achieved with most of the issues. For several potential problem areas compromises were needed and will be needed in the future. Where divergent regional requirements remain, these are addressed by ISO/TS 3691-7:2011 and ISO/TS 3691-8.

In order to ensure that the revised International Standard will be actively used in the ISO member countries, worldwide, procedures will be necessary to replace the existing national standards and technical regulations by the revised International Standard. In the European Community, ISO and the European Committee for Standardization (CEN) agreed on technical co-operation under the Vienna Agreement, with the aim of replacing European Standards (EN) by International Standards. Other countries are asked to make similar agreements to ensure that their national standards and technical regulations are replaced by this International Standard.

Only by these actions will there be the guarantee that products in accordance with International Standards can be shipped worldwide freely without any technical barriers.

Industrial trucks — Safety requirements and verification —

Part 1:

Self-propelled industrial trucks, other than driverless trucks, variable-reach trucks and burden-carrier trucks

1 Scope

This part of ISO 3691 gives safety requirements and the means for their verification for the following types of self-propelled industrial trucks (hereafter referred to as *trucks*), as defined in ISO 5053:

- a) industrial counterbalanced trucks;
- b) reach trucks with retractable mast or retractable fork arm carriage;
- c) straddle trucks;
- d) pallet-stacking trucks;
- e) high-lift platform trucks;
- f) trucks with elevating operator position up to 1 200 mm;
- g) side-loading trucks (one side only);
- h) lateral-stacking trucks (both sides), and lateral- and front-stacking trucks;
- i) pallet trucks;
- j) bidirectional and multidirectional trucks;
- k) tractors with a drawbar pull up to and including 20 000 N;
- l) rough-terrain counterbalanced trucks;
- m) industrial trucks powered by battery, diesel, gasoline or LPG (liquefied petroleum gas).

NOTE 1 Trucks powered by CNG (compressed natural gas) are not dealt with. It is intended that CNG and other power sources be addressed in future revisions of this part of ISO 3691.

For trucks with an elevating operator position of more than 1 200 mm and/or trucks designed to travel with an elevated load of more than 1 200 mm, this part of ISO 3691 is intended to be used in conjunction with ISO 3691-3.

NOTE 2 ISO 3691-3 is not applicable to counterbalanced fork lift trucks or trucks intended for container handling.

NOTE 3 Some low-level order pickers with an elevating operator's position up to and including 1 200 mm lift height can be equipped with an additional lifting device to lift the load to a maximum lift height of 1 800 mm.

This part of ISO 3691 is not applicable to self-propelled variable-reach trucks, driverless trucks or burden carriers, which are covered in ISO 3691-2, ISO 3691-4 and ISO 3691-6, respectively.

It is not applicable to industrial trucks operating in severe conditions (e.g. extreme climates, freezer applications, hazardous environments), where special precautions can be necessary.

Regional requirements, additional to the requirements given in this part of ISO 3691, are addressed in ISO/TS 3691-7 and ISO/TS 3691-8.

This part of ISO 3691 deals with all significant hazards, hazardous situations or hazardous events, as listed in Annex B, with the exception of the following, relevant to the applicable machines when used as intended and under conditions of misuse which are reasonably foreseeable by the manufacturer.

It does not establish requirements for hazards that can occur

- during construction,
- when handling suspended loads that can swing freely,
- when using trucks on public roads,
- when operating in potentially explosive atmospheres,
- when using trucks in very narrow aisles with clearance of less than 500 mm to the racks,
- arising from a non-ergonomic body attitude when driving sit-on trucks, load trailing,
- during travelling with unladen trucks having a rated capacity of more than 10 000 kg, due to visibility concerns,
- due to overload.

NOTE 4 For the purposes of this part of ISO 3691, fork arms, load platforms and integrated attachments are considered to be parts of the industrial truck. Attachments mounted on the load carrier or on the fork arms which are removable by the user are not considered to be part of the industrial truck. Requirements for attachments are given in the appropriate clauses.

2 Normative references

The following referenced documents are indispensable for the application of this document. For dated references, only the edition cited applies. For undated references, the latest edition of the referenced document (including any amendments) applies.

ISO 2328:2007, *Fork-lift trucks — Hook-on type fork arms and fork arm carriages — Mounting dimensions*

ISO 2330, *Fork-lift trucks — Fork arms — Technical characteristics and testing*

ISO 2867:2006, *Earth-moving machinery — Access systems*

ISO 3287:1999, *Powered industrial trucks — Symbols for operator controls and other displays*

ISO 3411:2007, *Earth-moving machinery — Physical dimensions of operators and minimum operator space envelope*

ISO 3691-3:—¹⁾, *Industrial trucks — Safety requirements and verification — Part 3: Additional requirements for trucks with elevating operator position and trucks specifically designed to travel with elevated loads*

ISO 3691-5:2009, *Industrial trucks — Safety requirements and verification — Part 5: Pedestrian-propelled trucks*

ISO 3795:1989, *Road vehicles, and tractors and machinery for agriculture and forestry — Determination of burning behaviour of interior materials*

ISO 5053, *Powered industrial trucks — Terminology*

ISO 6055:2004, *Industrial trucks — Overhead guards — Specification and testing*

ISO 6292:2008, *Powered industrial trucks and tractors — Brake performance and component strength*

ISO 12100:2010, *Safety of machinery — General principles for design — Risk assessment and risk reduction*

ISO 13284:2003, *Fork-lift trucks — Fork-arm extensions and telescopic fork arms — Technical characteristics and strength requirements*

ISO 13564-1:—¹⁾, *Powered industrial trucks — Test methods for verification of visibility — Part 1: Sit-on and stand-on operator trucks up to and including 10 t capacity*

ISO 13849-1:2006, *Safety of machinery — Safety-related parts of control systems — Part 1: General principles for design*

ISO 13850:2006, *Safety of machinery — Emergency stop — Principles for design*

ISO 15870:2000, *Powered industrial trucks — Safety signs and hazard pictorials — General principles*

ISO 15871:2000, *Industrial trucks — Specifications for indicator lights for container handling and grapple arm operations*

ISO 20898:2008, *Industrial trucks — Electrical requirements*

ISO 21281:2005, *Construction and layout of pedals of self-propelled sit-down rider-controlled industrial trucks — Rules for the construction and layout of pedals*

ISO 22915-1:2008, *Industrial trucks — Verification of stability — Part 1: General*

ISO 22915-2:2008, *Industrial trucks — Verification of stability — Part 2: Counterbalanced trucks with mast*

ISO 22915-3:2008, *Industrial trucks — Verification of stability — Part 3: Reach and straddle trucks*

ISO 22915-4:2009, *Industrial trucks — Verification of stability — Part 4: Pallet stackers, double stackers and order-picking trucks with operator position elevating up to and including 1 200 mm lift height*

ISO 22915-7:2009, *Industrial trucks — Verification of stability — Part 7: Bidirectional and multidirectional trucks*

ISO 22915-8:2008, *Industrial trucks — Verification of stability — Part 8: Additional stability test for trucks operating in the special condition of stacking with mast tilted forward and load elevated*

ISO 22915-10:2008, *Industrial trucks — Verification of stability — Part 10: Additional stability test for trucks operating in the special condition of stacking with load laterally displaced by powered devices*

1) To be published.

ISO 22915-11:—²⁾, *Industrial trucks — Verification of stability — Part 11: Industrial variable-reach trucks*

ISO 22915-20:2008, *Industrial trucks — Verification of stability — Part 20: Additional stability test for trucks operating in the special condition of offset load, offset by utilization*

ISO 22915-21:2009, *Industrial trucks — Verification of stability — Part 21: Order-picking trucks with operator position elevating above 1 200 mm*

ISO 24134:2006, *Industrial trucks — Additional requirements for automated functions on trucks*

ISO 24135-1:2006, *Industrial trucks — Specifications and test methods for operator restraint systems — Part 1: Lap-type seat belts*

IEC 60695-11-10:2003, *Fire hazard testing — Part 11-10: Test flames — 50 W horizontal and vertical flame test methods*

3 Terms and definitions

For the purposes of this document, the terms and definitions given in ISO 5053 and ISO 12100 and the following apply.

3.1 self-propelled industrial truck
wheeled vehicle having at least three wheels with a powered driving mechanism, except for those running on rails, designed either to carry, tow, push, lift, stack or tier in racks any kind of load and controlled by an **operator** (3.7)

NOTE See ISO 5053 for a comprehensive terminology.

3.2 pedestrian-controlled truck
truck designed to be controlled by an **operator** (3.7) walking with the truck by means of, for example, a tiller or remote control

NOTE The truck may be equipped with a stand-on option.

3.3 ride-on truck
truck designed to be controlled by an **operator** (3.7) riding on a seat or a driving platform on the truck

NOTE Stand-on industrial trucks with a seat for the operator are considered as being stand-on trucks.

3.4 low-lift truck
truck having a lift height of 500 mm or less

3.5 bidirectional truck
truck designed to travel in either direction on a line parallel with its longitudinal axis, or perpendicular to this axis

NOTE Adapted from ISO 5053:1987, 3.6.1.2.

2) To be published.

3.6

multidirectional truck

truck designed to travel in any direction relative to its longitudinal axis

NOTE Adapted from ISO 5053:1987, 3.6.1.3.

3.7

operator

designated person, appropriately trained and authorized, who is responsible for the movement and load handling of an industrial truck

NOTE 1 Depending on the truck type, the operator can be riding on the industrial truck, on foot accompanying the truck (e.g. tiller-, cable-controlled) or remote from the truck (e.g. remote radio-controlled).

NOTE 2 National regulations can apply.

3.8

normal operating position

position in which the operator is able to control all functions for driving and load handling as defined by the manufacturer

NOTE Additional positions are permitted to be defined by the manufacturer if it is not possible to control all the functions of the truck from a single position. A rotating seat or stand-up end-control truck with more than one operating direction is considered as being or having a single operating position.

3.9

lift height

vertical distance between the upper face of the fork blades or the lifting platform and the ground

3.10

lift height for travelling

lifting height up to and including 500 mm providing sufficient ground clearance for travelling

NOTE It is identical to the maximum lift height for the stability test for travelling.

3.11

low lift height

maximum lift height up to and including 500 mm, where the vertical centre of gravity of the load does not exceed 1 100 mm above the ground

3.12

automatically acting brakes

mechanical brakes which automatically apply in the non-travelling condition until released by the control of the operator

3.13

lost load centre

horizontal shift in the standard load centre that may occur when removable attachments are added to a truck

NOTE For standard load centre, see Annex A.

3.14

actual capacity

maximum load, expressed in kilograms, established by the manufacturer based on component strength and truck stability, that a truck can carry, lift and stack to a specified height, at a specified load centre distance and reach, if applicable, in normal operation

NOTE The actual capacity depends on the configuration of the truck, including variables such as the type and lift height of the mast fitted, the actual load centre and any attachments that might be fitted. This actual capacity defines the

load-handling ability of the particular truck, as equipped. Additional actual capacity ratings with removable attachments can also be established where permitted by the appropriate stability tests or by calculation verified by empirical data.

3.15 rated capacity

maximum load, expressed in kilograms, established by the manufacturer based on component strength and truck stability, that the truck can carry, lift and stack to the standard lift height and at the standard position of the centre of gravity

NOTE 1 For centre of gravity, see Annex A.

NOTE 2 If the lifting height of the mast is lower than the standard lift height, H , the rated capacity is still assessed at the standard lift height.

NOTE 3 The rated capacity is used to compare the capacity of different manufacturers' trucks and to provide the break points used in technical standards and statistics. The operating limits for the truck are defined by its actual capacity.

4 Safety requirements and/or protective measures

4.1 General

4.1.1 Overall requirements

The truck shall comply with the safety requirements and/or protective measures of this clause.

In addition, the truck shall be designed according to the principles of ISO 12100 for relevant but not significant hazards which are not dealt with by this document.

4.1.2 Normal climatic conditions

For truck operation, the following climatic conditions apply:

- average ambient temperature for continuous duty: + 25 °C;
- maximum ambient temperature, short term (up to 1 h): + 40 °C;
- lowest ambient temperature for trucks intended for use in normal indoor conditions: + 5 °C;
- lowest ambient temperature for trucks intended for use in normal outdoor conditions: – 20 °C;
- altitude: up to 2 000 m.

4.1.3 Normal operating conditions

Normal operating conditions are the following:

- driving (travelling and lifting) on substantially firm, smooth, level and prepared surfaces — the surface conditions on which the truck is designed to operate shall be specified in the instruction handbook (see 6.2);
- driving with the horizontal load centre of gravity approximately on the longitudinal centre plane of the truck;
- travelling with the mast or fork arms tilted backwards, where applicable, and the load in the lowered (travel) position.

If the above is not sufficient to allow the conditions for stability of a particular truck type to be specified, then the operating conditions shall be according to the International Standards referenced for stability in 4.8.

4.1.4 Electrical requirements

Electrical requirements are subject to regional requirements. See ISO/TS 3691-7:2011 and ISO/TS 3691-8.

4.1.5 Edges or angles

There shall be no sharp edges or angles posing a hazard in the area of the operator in the normal operating position or in the area of access and egress during normal operation and daily checks.

4.1.6 Stored energy components

Components which store energy and that would cause a risk during removal or disassembly, e.g. hydraulic accumulator or spring-applied brakes, shall be provided with a means to release the energy before removal or disassembly.

4.2 Starting/moving

4.2.1 Unauthorized starting

Trucks shall be provided with a device (e.g. key, code, magnetic card) which prevents starting without its use.

Such devices for pedestrian-controlled and rider-controlled trucks manufactured by the same manufacturer shall not be interchangeable between the two truck types. Where devices, e.g. magnetic cards, are destined for an individual operator, one device may be used on both truck types but shall not allow starting by unauthorized persons.

4.2.2 Unintended movement and inadvertent activation

Truck movement from the holding position, other than by actuation of the controls by the operator, due to drift or creep (e.g. by leakage), shall be avoided.

4.2.2.1 Parking brakes

A parking brake complying with 4.3.1 shall be provided.

For sit-on rider trucks, the parking brake system should be manually operable by hand or foot from the normal operating position or automatically applied by leaving the normal operating position. Trucks with only non-automatically applied parking brake(s) shall have a warning to the operator to apply the brakes before leaving the truck.

Failure of the control system of an automatically applied parking brake shall be indicated to the operator.

4.2.2.2 Internal-combustion-engine powered trucks

Internal-combustion-engine powered trucks shall be fitted with a device which prevents the engine being started while the transmission is engaged.

4.2.2.3 Travel controls

Travel controls on internal-combustion-engine powered trucks shall be so arranged that on level ground the truck will not move from rest until the transmission has been engaged.

4.2.2.4 Powered travel movement

Powered travel movement of the truck with a ride-on operator shall be possible only if the operator is in the normal operating position.

Powered travel shall not occur automatically when the operator returns to the normal operating position without an additional operation, e.g. by requiring a resetting of the direction control or reactivation of the speed control.

4.2.2.5 Manual gearbox and manually operated clutch pedal

A truck with an automotive-type manual gearbox and manually operated clutch pedal satisfies the requirements of 4.2.2.2 and 4.2.2.4.

4.2.3 Travel speed

4.2.3.1 Pedestrian-controlled trucks

Single-speed pedestrian-controlled trucks operating on level ground shall not exceed a travel speed of 4 km/h and an acceleration of 0,5 m/s² and shall be designed for low-lift only.

Variable-speed pedestrian-controlled trucks operating on level ground shall be controllable by the operator to be aligned with their walking speed.

The maximum speed is subject to regional requirements, additional to the requirements of this part of ISO 3691. See ISO/TS 3691-7:2011 and ISO/TS 3691-8.

4.2.3.2 Stand-on trucks and pedestrian-controlled trucks with foldable platform

The maximum speed on level ground of stand-on trucks and pedestrian-controlled trucks fitted with a foldable platform when the operator is on the platform is subject to regional requirements, additional to the requirements of this part of ISO 3691. See ISO/TS 3691-7:2011 and ISO/TS 3691-8.

For trucks with a foldable operator platform, see 4.7.3.3.

For trucks with stand-on options, see 4.7.3.2 and 4.7.3.4.

4.2.3.3 Travel with mast raised

Travel with mast raised is subject to regional requirements. See ISO/TS 3691-8.

4.3 Brakes

4.3.1 General

All industrial trucks shall be designed with service and parking brakes. Brakes shall comply with ISO 6292.

The parking brake shall be equipped with a system preventing unintentional release. The parking brake force shall be applied by mechanical means.

Braking requirements are subject to regional requirements, additional to the requirements of this part of ISO 3691. See ISO/TS 3691-7:2011 and ISO/TS 3691-8.

4.3.2 Failure of energy supply to service brake

Failure of the energy supply to the service brake shall not result in a total loss of braking and shall enable a controlled stop.

4.3.3 Stand-on and pedestrian-controlled trucks

Stand-on and pedestrian-controlled trucks shall be equipped with a brake system that will automatically engage upon release of the brake actuating control by the operator. This system may serve as the service and parking brake.

4.4 Manual control actuators

4.4.1 General

4.4.1.1 Consistency with the truck motions

Movement of these controls shall be consistent with the motions of the truck being operated, wherever practicable. They shall be confined within the plan view outline of the truck or tiller.

4.4.1.2 Multiple operators

If additional operating positions are fitted, e.g. for more than one operator, the operation of these controls shall only be possible from one operating position at a time, excepting the emergency disconnect switch, which shall be operable from all positions.

4.4.1.3 Multiple operating positions

If more than one operating position is fitted for a single operator, the use of the controls for one of these operating positions shall preclude the use of the controls of another operating position. The exception to this is the emergency disconnect switch, which shall be operable from all positions.

4.4.2 Travel and braking controls

4.4.2.1 General

The motion of the speed operating control shall be so designed that an increase in the movement of the control increases the travel speed. When the control is released, it shall return to the neutral position of the control actuator.

4.4.2.2 Sit-on trucks

Trucks with pedal-operated travel and braking controls shall comply with ISO 21281.

4.4.2.3 Stand-on trucks

The requirements for travel and braking controls for a stand-on truck are as follows.

a) Travel control functions

- Where a tiller is used, it shall be fitted with control devices for travel direction and speed.
- Where a steering wheel or similar control is used, the controls for travel direction and speed shall be positioned in close proximity to the steering control.

The service brake function shall be engaged

- automatically when the tiller is released, if operated by the tiller,
- automatically when the travel-control is released, if operated by the travel-control,

- automatically when releasing the pedal, if the brake function is foot-operated,
- when activating the hand actuator, if the brake function is hand-operated.

b) Trucks with elevating operator platform up to 1 200 mm

Means shall be provided to prevent travel while the platform is elevated more than 500 mm, unless the controls are elevated with the platform.

4.4.2.4 Pedestrian-controlled trucks

The requirements for pedestrian-controlled trucks are as follows.

- a) The tiller shall be fitted with control devices for travel direction and speed.
- b) When the tiller is released, it shall automatically return to its upper rest position, cut off traction power in the travel direction and engage the brake.
- c) When the tiller is in its lowered position, the traction power in the travel direction shall be cut off and the brake shall be engaged.
- d) The tiller shall be fitted with a device to energize the direction of travel away from the operator until pressure on the device is relieved, or that stops the truck by applying the brakes, if the head of the tiller in its operating position comes into contact with a solid body (e.g. the operator's body).

4.4.2.5 Differential locking

It shall be possible to unlock the differential when the truck is moving.

For trucks fitted with a pedal-operated differential lock, depression of the pedal shall lock the differential and shall be released when releasing the pedal.

4.4.2.6 Additional operation from outside the truck

If travel control from outside the truck is provided for the operator of sit-on or stand-on trucks and tractors, when operated from the outside the travel speed shall be limited to 6 km/h. These controls may be attached to the truck or a remote control may be provided, and the operating system shall be made operable by means of a separate switch or automatically when the operator leaves the normal operating position.

a) General

- 1) If the control actuator is released, the drive unit shall switch off automatically and the brake shall be engaged automatically. Simultaneous operation from the operating positions shall be excluded.
- 2) Controls fitted at the outside of the truck shall be secured against unintentional activation.

b) Additional requirements for cable-connected remote controls

- 1) The length and layout of the cables shall allow the operator to operate from outside of the area of hazard of the truck and have visibility of the path of travel. It shall not be possible for the cable to become entangled with the wheels.
- 2) On a portable control panel, the control elements, with the exception of the emergency stop, shall be guarded against unintentional operation. The portable control panel shall be fitted with an emergency stop device in accordance with ISO 13850.

c) Additional requirements for cableless control

- 1) The transmission range shall be adequate to allow the operator to operate from outside the area of hazards of the truck and have visibility in the path of travel.
- 2) On the portable control panel, the control elements for operation, with the exception of the emergency stop, shall be guarded against unintentional operation.
- 3) The reliability level shall be at least 10^{-9} and the Hamming distance shall be 2. The remote control shall be in accordance with ISO 13849-1, performance level (PL) c.
- 4) The truck shall stop automatically when outside of the operator's direct view (90°) and/or out of range of the remote control.
- 5) No control interference shall be possible when more than one truck is operating under remote control at the same time.

d) Additional requirements for trucks with trailer coupling

- 1) The controls (e.g. rear touch device) shall be arranged so that the operator does not have to step between the truck and the trailer in order to operate them.
- 2) The rear touch device shall be secured against unintentional operation.
- 3) During operation of the rear touch device, the travel speed of the truck shall not exceed 2,5 km/h.

4.4.2.7 Additional operation from alongside pedestrian-controlled and stand-on trucks (coasting)

The additional operation of pedestrian-controlled and stand-on trucks while the operator is walking alongside the truck shall only be possible with the truck's fork arms trailing.

The additional operation of such trucks while the operator is walking alongside the truck, and the use of low-lift order-picking trucks provided with a system that allows for operation while walking alongside the truck, are subject to regional requirements, additional to the requirements of this part of ISO 3691. See ISO/TS 3691-7:2011 and ISO/TS 3691-8.

4.4.3 Steering controls

4.4.3.1 Steering direction

The following applies.

- a) For stand-on or sit-on trucks, when travelling in the forward direction, clockwise rotation of the steering wheel, or equivalent movement of the steering control, shall steer the truck to the right.
- b) For trucks with an operator control position rotatable by more than 90° , or having duplicated control positions, in order to facilitate the operator facing in the opposite direction, clockwise rotation of the steering wheel, or equivalent movement of the steering control, shall steer the truck to the right as viewed from the new position — i.e. the steering control sense is reversed beyond 90° to facilitate the operator facing in the opposite direction.
- c) Trucks with continuous 360° steering — i.e. the steering/drive wheel can move through 360° to propel the truck in the direction selected by the steering control — shall operate in the same sense as a), above, when travelling in the forward direction.
- d) For pedestrian-operated trucks fitted with a tiller, when travelling in the forward direction, clockwise movement of the tiller shall steer the truck to the right.
- e) Exceptionally, when requested by the user, end-control trucks may be equipped with “reverse steering” — i.e. clockwise rotation of the steering control will steer the truck to the left. Such trucks should be clearly identified.

4.4.3.2 Failure of power supply

In the event of an interruption of the power supplied to the steering system (including a dead motor or engine), it shall be possible to maintain the path being steered until the truck is brought to a controlled stop.

4.4.4 Load-handling controls

4.4.4.1 Controls

Controls shall return to the neutral position when released and stop the corresponding load movement. When single levers are used to control a function on trucks other than reach trucks with retractable mast or forks, the lever closest to the operator shall control lifting and lowering, the second closest lever should control the tilt function, the third closest lever should control the side shift and the fourth closest lever should be for auxiliary functions.

When single levers are used to control a function on reach trucks with a retractable mast or forks, the lever closest to the operator shall control lifting and lowering, the second closest lever should control the displacement of the mast or forks, the third closest lever should control the tilt function, the fourth closest lever should control side shift and the fifth closest lever should be for auxiliary functions.

Trucks equipped with attachments which hold the load by power (e.g. paper clamp) shall feature control(s) with a secondary action to prevent unintentional release of the load.

Table 1 — Levers or handle-type controls with single operation, sequence of location and direction of movement

Function (listed in sequence of location)	Direction of movement	
	Motion of load or equipment	Predominant motion of operator's hand when actuating control handle while facing load
Hoist	Up	Rearward or up
	Down	Forward or down
Reach	Retract	Rearward
	Extend	Forward
Tilt	Rearward	Rearward or up
	Forward	Forward or down
Side shift	Right	Rearward or up
	Left	Forward or down
Push-pull	Rearward	Rearward
	Forward	Forward
Rotate laterally	Clockwise	Rearward or up
	Counter clockwise	Forward or down
Rotate longitudinally	Rearward	Rearward or up
	Forward	Forward or down
Load stabilizer	Down	Rearward or up
	Up	Forward or down
Fork position	Together	Rearward or up
	Apart	Forward or down
Grip	Engage	Rearward or up
	Release	Forward or down
Truck stabilizer	Raise	Rearward or up
	Lower	Forward or down
Clamp	Clamp	Rearward or up
	Release	Forward or down

4.4.4.2 Manual-lift systems

The hand power forces and the layout of controls of manually operated lifting systems shall comply with ISO 3691-5.

4.4.5 Multi-function controls

Where a control is designed and constructed to perform more than one function, each separate function shall be clearly marked. Each control function shall return to the neutral position when released and stop the corresponding load movement.

4.4.6 Controls for automated functions

The controls for automated functions shall comply with ISO 24134.

4.4.7 Marking

Graphic symbols used for marking controls shall comply with 6.3.1.4.

4.5 Power systems and accessories

4.5.1 Exhaust and cooling systems

4.5.1.1 Exhaust systems

The exhaust system shall be designed in accordance with 4.7.6 and such that engine exhaust is directed away from the operator position. Materials used in the vicinity of exhaust systems shall be non-flammable and shall be chosen and protected such that they are not adversely affected by heat from the exhaust system.

4.5.1.2 Cooling systems

The air flow through the cooling system shall be arranged so as to avoid discomfort to the operator.

4.5.2 Fuel tank

4.5.2.1 Tank isolation

If a fuel tank is within or adjacent to the engine compartment and excessively high temperatures can occur, the tank and/or filling arrangement shall be isolated from the electrical and exhaust systems by suitable protection, e.g. a separate enclosure or baffles. The tank location and facilities for filling shall be such that spillage or leakage will not drain into the engine or operator's compartment or onto electrical or exhaust system parts.

4.5.2.2 Fuel spillage

Fuel spillage shall not be possible under normal operating conditions.

4.5.3 Access to engine and other compartments

4.5.3.1 Engine covers

An enclosed engine compartment shall satisfy fan guarding requirements when the manufacturer's recommended routine maintenance is performed with the engine off. If a fan can start (e.g. temperature switch) when the engine is off, the fan shall be guarded. A safety warning sign shall be provided, and included in the instruction handbook (see 6.2). Warnings shall comply with 6.3.3.4.

Access from underneath is considered guarded if the access ground clearance is less than 600 mm between the underside of the truck and level ground.

4.5.3.2 Unintentional closure

Where unintentional closure could cause injury, access covers (i.e. traction battery or engine covers) shall be provided with means for preventing unintentional closure. Those means shall be permanently affixed to the truck or stored in a safe place on the truck.

4.5.4 Liquefied petroleum gas (LPG)-powered trucks

4.5.4.1 Containers

The following applies to the containers of trucks powered by LPG.

- a) LPG containers shall be either permanently fixed to the truck or removable.
- b) When LPG containers are removable, their fastenings shall permit easy handling and checking of the installation after the exchange of containers.
- c) Removable LPG containers that incorporate a pressure-relief valve shall be so positioned on the truck that the pressure-relief valve opening is always in communication with the vapour space at the top of the container. This may be accomplished, for example, by an indexing pin which positions the container when the container is properly installed.
- d) LPG containers shall be securely mounted to the truck to prevent movement. Fastening shall withstand static loading of four times the filled container weight in any direction without permanent visible deformation.
- e) LPG containers shall be fitted on the truck such that exposure to abrasion, shock and the corrosive action of the products handled by the truck is reduced.
- f) LPG containers and their connections shall be installed such that there are no projections outside the plan view outline of the truck.
- g) If LPG containers are installed in a compartment, this compartment shall have permanent openings at the bottom. The total surface area of these ventilation openings shall be at least 200 cm² allowing adequate ventilation to outside the truck.
- h) If an additional LPG container is carried on the truck, it shall be secured in the same manner as the main container.
- i) LPG containers, whether fixed or removable, shall be equipped with a device to prevent unintentional emission of gas or liquid, e.g. in the case of a pipe system failure. This does not apply to pressure-relief valves.
- j) Pipe fittings and accessories on LPG containers shall be protected against mechanical damage when used as specified by the manufacturer.
- k) The fuel take-off on the LPG container shall be equipped with an easily and quickly accessible manually operated valve. The position and method of operation of this valve shall be clearly marked on the valve handle or on the outside of the truck near the valve.
- l) The fuel take-off shall be in a liquid form, unless the LPG container and engine are specially equipped for a direct vapour withdrawal.

- m) Permanently mounted LPG containers to be filled by the user shall be fitted with the following:
- 1) a pressure-relief valve connected to the vapour space of the container that, when fitted inside the compartments of trucks, shall have the discharge side of the relief valve piped to the atmosphere away from the operator and that shall comply with 4.5.4.3 d);
 - 2) an 80 % fill stop valve;
 - 3) maximum liquid level devices suitable for the LPG in use, indicating the maximum product level and which shall not vent to the atmosphere.
- n) LPG containers shall be positioned such that they are not exposed to the damaging effects of heat, particularly heat from the engine or the exhaust system. If it is necessary to fit a heat shield, this shall not inhibit ventilation.

4.5.4.2 Piping

The following applies to the piping used on trucks powered by LPG.

- a) Connecting piping and all associated parts shall be easily accessible, protected against excessive heat radiation, damage and wear, and shall be flexible enough to withstand vibration and deformation in service, as follows:
- piping shall be so arranged that damage or leaks are easily detectable and that checks and maintenance can be carried out;
 - piping shall be installed such that it cannot be damaged by any excessive heat radiation from hot parts of the truck;
 - fully rigid pipes shall not be used for connecting the container to equipment on the engine;
 - piping shall be so arranged that there are no projections outside the plan view outline of the truck.
- b) Pressure hoses operating above 1 bar³⁾ shall be supported at least every 500 mm. Rigid pipes shall be supported at least every 600 mm.
- c) Hoses, pipes and all connections operating at pressures above 1 bar shall be suitable for a working pressure of 25 bar and shall withstand without bursting a test pressure of 75 bar. Hoses, pipes and all connections operating below 1 bar shall withstand without bursting a test pressure of five times the maximum working pressure.
- d) Pressure shall not exceed the working pressure rating of components in any section of pipe work containing LPG in liquid form between two shut-off valves that are closed; a pressure-relief valve, for example, or other suitable means, may be used if necessary.
- e) Aluminium piping shall not be used.
- f) Hoses shall be as short as practical.
- g) Pressure unions and joints operating above 1 bar shall be made of metal, except for any constrained sealing washers.

3) 1 bar = 0,1 MPa = 0,1 N/mm² = 10⁵ N/m².

4.5.4.3 Equipment

The following applies to the equipment used on trucks powered by LPG.

- a) The supply of gas shall be automatically cut off when the engine stops, irrespective of whether or not the ignition system has been switched off.
- b) For multi-fuel applications, the system shall be designed to avoid the possibility of LPG entering any other fuel container and to shut off each fuel source before the alternative one is opened.
- c) If the truck is equipped with two or more containers to supply fuel, they shall be connected via a multi-way valve or other suitable means, so that LPG can only be drawn from one container at a time. The use of two or more containers at the same time shall not be possible.
- d) Pressure-relief valves or liquid-level indicators shall be installed such that they cannot discharge in the direction of the operator or onto truck components that could be a source of ignition.
- e) If corrosion of a part would interfere with its proper functioning, that part shall be provided with a corrosion-resistant protective coating.
- f) All fuel system components shall be firmly secured to the truck.
- g) Pressure-reducing valves shall be readily accessible for inspection and maintenance.
- h) The engine compartment shall be designed in accordance with 4.5.4.1 g), in order to avoid any LPG accumulation.

4.5.4.4 Regional requirements

LPG-powered trucks are subject to regional requirements, additional to the requirements of this part of ISO 3691. See ISO/TS 3691-8.

4.6 Systems for lifting and tilting

4.6.1 Lift chains

The truck or mast manufacturer shall have on record a certificate from the chain manufacturer giving the breaking load of the chains used.

When the lifting mechanism includes a chain or chains, the truck manufacturer shall only use leaf or roller chains. These shall provide a minimum factor, K_1 , when supporting the maximum capacity load and assuming no friction in the mast structure, which is given by the following equation:

$$K_1 = (L_c \times n) / (R + w)$$

where

K_1 is the safety factor of the lifting mechanism;

L_c is the minimum breaking load for new chain;

n is the number of chains;

R is the maximum load capacity of the truck;

w is the dead weight of the lifting mechanism supported by the chains.

The K_1 factor is subject to regional requirements, additional to the requirements of this part of ISO 3691. See ISO/TS 3691-7:2011 and ISO/TS 3691-8.

Pulley diameters shall be in accordance with the chain manufacturer's instructions.

4.6.2 Mechanical lifting systems

4.6.2.1 General

The lifting system shall comply with the requirements of 4.6.3.3.

4.6.2.2 Failure of lifting/lowering mechanism

In the event of failure of a single lifting/lowering part of the mechanism (e.g. gearwheel, chainwheel or spindle), it shall not cause the elevated load or operator's platform to descend uncontrolled.

4.6.2.3 Lowering speed

The lowering speed of the lifting mechanism with its rated load shall not exceed 0,6 m/s.

4.6.3 Hydraulic lifting and tilting systems

4.6.3.1 Hydraulic lifting systems

The hydraulic lifting system shall be designed such that, with the hydraulic fluid at normal operating temperature, the mast substantially vertical and carrying rated capacity load, the descent of the load caused by internal leakage in the first 10 min shall not exceed

- 100 mm for trucks up to and including 10 000 kg rated capacity,
- 200 mm for trucks over 10 000 kg rated capacity.

4.6.3.2 Lowering speed limitation

A device shall be incorporated in the lift circuit which, in the event of a failure of the hydraulic circuit — excluding the hydraulic lift cylinder(s) — shall restrict the rate of descent of the lifting mechanism with its rated load to 0,6 m/s maximum. The device shall be fitted directly at the lifting cylinder(s).

4.6.3.3 Limitation of stroke

The lift assembly shall be fitted with a positive means to prevent over-travel. In addition, positive means (e.g. mechanical stop) shall be provided to prevent the fork carrier and moving elements of the mast structure from unintentionally disengaging from the upper end of the mast.

4.6.3.4 Hydraulic tilting systems

The internal leakage rate of the complete hydraulic tilting system (i.e. cylinder, valve, etc.), with the oil at normal operating temperature, shall allow no more than 5° forward movement of the mast in 10 min from the vertical mast position, when the rated load is at a height of 2 500 mm or, in the case of trucks with lift heights less than 2 500 mm, at their maximum lift height. The average tilting speed allowed by internal leaks shall not exceed 0,5°/min for trucks with a maximum forward tilt of less than 5°.

4.6.3.5 Mast tilt and carriage isolation

For ride-on trucks, mast tilt and carriage movement shall not be possible through operation of the primary load-handling control when the operator is not in the normal operating position.

Isolation of attachment movement is subject to regional requirements, additional to the requirements of this part of ISO 3691. See ISO/TS 3691-7:2011.

4.6.4 Hydraulic systems

4.6.4.1 Hydraulic circuits

Hoses, piping and connections subjected to internal pressure shall be capable of withstanding, without bursting or permanent deformation, a pressure equal to at least three times the operating pressure. Pipes and hoses shall be located and, if necessary, restrained, so that deterioration, sharp edges and other damage-causing sources are minimized.

4.6.4.2 Pressure controls

All hydraulic systems shall include a device which prevents the pressure in the system from exceeding a preset level. The device shall be so designed and fitted that unintentional loosening or adjustment is avoided and so that a tool or key is required to alter the pressure setting.

4.6.4.3 Failure of energy supply to hydraulic circuits

In the case of a fault or interruption of the supply of energy, the design of the hydraulic system shall be such that it does not allow any uncontrolled motion of equipment or attachment.

4.6.4.4 Fluid purification

The hydraulic system(s) shall be protected against the risk of contamination of the hydraulic fluid, e.g. by means of magnet(s) or filter(s).

4.6.5 Load-handling and -stacking attachments

4.6.5.1 Unintentional displacement or detachment

Means shall be provided to prevent the unintentional lateral displacement or unintentional detachment of attachments from the truck. Movement of the attachment and its parts shall be mechanically limited at the extreme positions.

4.6.5.2 Malfunction in the power supply system

Attachments that hold the load by power shall be designed such that the maximum load they are intended to handle is automatically retained for at least 10 min when the truck's manual controls are in the neutral position or in the event of a malfunction in the power supply system for the attachment.

4.6.5.3 Hydraulic system for attachment

If an attachment has its own separate hydraulic system, it shall comply with 4.6.4.

4.6.5.4 Combined hydraulic systems

If an attachment has a hydraulic system connected to the truck hydraulic system, the two systems shall be compatible and the combined systems shall comply with 4.6.4.

4.6.5.5 Attachments for lifting freight containers

An attachment for lifting freight containers shall be equipped with indicator lights according to ISO 15871. The attachment shall have a device(s) to prevent unintentional disengagement of a container. Means shall be provided to prevent lifting of the container for transport unless all interface mechanisms are fully engaged and

locked. If multiple containers are lifted at the same time, the same requirements are valid for all containers. Travel speed shall be restricted to a maximum of 10 km/h if the container is not locked to the attachment in a manner that will prevent unintentional drop (e.g. lifting with grapple arms).

4.6.5.6 Fork arms

4.6.5.6.1 Solid-section fork arms shall be manufactured and tested in accordance with ISO 2330, except with respect to safety factors. The safety factors are subject to regional requirements, additional to the requirements of this part of ISO 3691. See ISO/TS 3691-8.

4.6.5.6.2 The total capacity of all fork arms fitted to a truck shall not be less than the actual capacity of the truck.

4.6.5.6.3 Means shall be provided to prevent unintentional lateral displacement of the fork arms on the fork carrier.

4.6.5.6.4 Fork-arm extensions shall be designed to prevent accidental disengagement from the fork arms, and shall be in accordance with ISO 13284.

4.6.5.7 Fork carriers

Hook-on type fork carriers shall be in accordance with ISO 2328.

4.7 Operator positions

4.7.1 Dimensions

The operator's seat or standing position shall be so located that the operator has sufficient room while operating the truck so as to remain within the plan view outline of the truck. The dimensions shall be of suitable and ergonomic shape to accommodate at least a 5th percentile to a 95th percentile of the population, as shown in ISO 3411:2007, Figures 1 to 3, within the plan view outline of the truck. The seat shall not extend beyond the plan view outline of the truck.

The minimum distance from the top edge of the seat back to the plan view outline shall be 50 mm (see Figures 1 and 2).

For stand-on pedestrian- and centre-controlled ride-on trucks employing a tiller, the tiller steering control movement may extend beyond the plan view.

Dimensions in millimetres

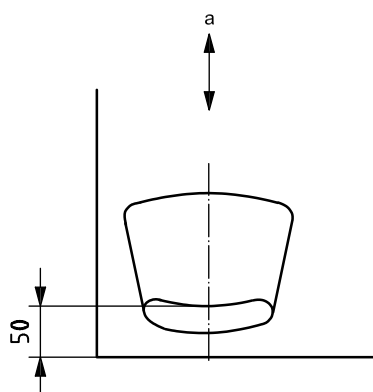

^a Direction of travel.

Figure 1 — Front-seated operator

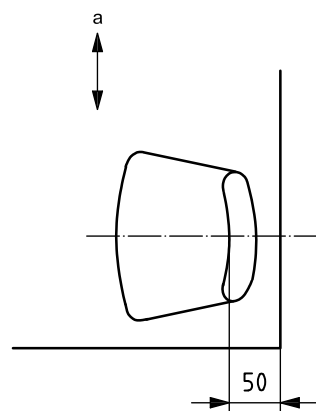

Figure 2 — Side-seated operator

4.7.2 Operator access and egress

4.7.2.1 General

Trucks shall be designed to permit safe and easy access and egress and to minimize the risk of slipping, falling and tripping. Steps, running boards and hand holds (grab handles, fixed parts of the truck structure, etc.) shall be provided above a step height of 350 mm to give three-point contact at all heights (i.e. one hand and two feet or two hands and one foot). Step width, instep clearance and toe clearance shall comply with ISO 2867.

4.7.2.2 Steps

Steps shall have slip-resistant surfaces or covering (e.g. expanded metal, abrasive coating). The first step shall be not more than 550 mm from the ground and succeeding steps shall be 250 mm to 350 mm, preferably at equal intervals.

4.7.2.3 Compartment floors

The compartment floor frequented by the operator, steps and walkways shall be free of obstacles and shall have a slip-resistant surface, e.g. ribbed mats, abrasive coating, expanded metal.

4.7.2.4 Walkways

Walkways more than 2 000 mm from the ground shall have guard rails. The guard rails shall have a height of 900 mm to 1 100 mm and shall be capable of withstanding, without permanent deformation, a force of 900 N applied in a horizontal direction from the inside to the outside.

4.7.2.5 Hand holds

For access to, and egress from, the normal operating position with a floor height above 300 mm, hand hold(s) shall be provided; these may be part of the truck structure. The clearance dimension for a hand hold shall be at least of 45 mm width, 130 mm length and diameter of 15 mm (see Figure 3).

Dimensions in millimetres

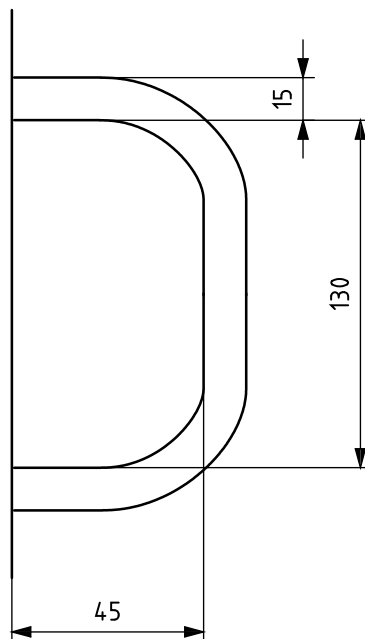

Figure 3 — Hand hold

4.7.3 Platforms

4.7.3.1 General

Operator stand-on platforms on pedestrian-controlled and stand-on end-controlled trucks shall be dimensioned in accordance with 4.7.1 and shall be capable of withstanding a compression force corresponding to 2,5 times the mass of the laden truck applied along the longitudinal axis of the truck with the outermost projection of the platform against a flat vertical surface. For the purpose of this requirement, the operator platform includes any surrounding reinforcement or parts of the truck which provide resistance to crushing of the platform, except for pedestrian-controlled stand-on trucks employing a tiller.

4.7.3.2 Platforms overhanging the truck chassis

Platforms overhanging the truck chassis on tiller-operated stand-on trucks, capable of travelling more than 6 km/h, shall, in addition to 4.7.3.1, be provided with a guard at either the sides or the front of the platform. The guards shall be capable of withstanding a horizontal force of 900 N acting from inside to outside applied in line with the centre of the operator's standing position without permanent deflection. The side guards shall be at a minimum height of 700 mm above the platform in its protective position.

4.7.3.3 Pedestrian-controlled trucks with foldable platforms

Operator stand-on platforms that are fitted to pedestrian-controlled trucks and overhang the truck's chassis may be capable of being folded or pivoted to an upright position when the operator leaves the platform; this may be done automatically.

For platforms which do not act automatically, devices shall be provided to prevent the truck manoeuvring or travelling unless the operator is standing on the platform or the platform is in its upper rest position.

Travelling of more than 6 km/h shall only be possible when the platform is pivoted down and guards are in their protective position.

4.7.3.4 Stand-on platforms

Operator stand-on platforms which are built within the plan view outline of pedestrian-controlled trucks, where the operator stands to the side of the motor housing, shall be equipped with an additional grab rail for operator stability when riding. This grab rail shall be capable of withstanding a horizontal force of 900 N applied in line with the operator's standing position, without permanent deformation. The requirements of 4.7.3.2 do not apply for this configuration of pedestrian-controlled truck.

4.7.3.5 Trucks with foldable platforms and foldable side guards

On trucks with side guards and platforms of the folding or pivoting type as described in 4.7.3.2 and 4.7.3.3, travelling movement shall only be possible when the side guard or platform is in a protective position or an inactive rest position. No travelling movement is allowed with the platform or side guard in an intermediate position.

4.7.4 Operator's seat

The seat shall be designed and located to provide easy access to the controls, shall provide a position for the truck operator in accordance with ergonomic principles and shall meet the following requirements.

- a) If the seat has a facility allowing fore and aft adjustment, this shall be possible without the use of tools.
- b) If a weight-adjustable seat is fitted to reduce vibration transmitted to the operator, the adjustment shall accommodate operator weights of 55 kg to 110 kg. Manual adjustment of the weight mechanism shall be possible without the use of tools.

- c) If a seat has a facility allowing it to swivel about a vertical axis, this shall be possible at all seat adjustment positions without unintentional operation of the controls.
- d) The seat mounting shall be able to withstand the forces which can occur during operation, e.g. braking forces, as well as the forces imposed by the operator restraint specified in 4.7.8.
- e) The requirements of a) to d), above, also apply to additional operator's seats.
- f) When using an auxiliary seat on a stand-on industrial truck, a padded seat surface and backrest is sufficient. If the operating space of the stand-on operator is restricted, the auxiliary seat shall be capable of being folded or pivoted.
- g) The seat anchorage to the battery cover or engine cover of sit-on counterbalanced trucks, as well as the latching method of the cover to the truck chassis, shall have sufficient strength in the event of a backwards tip-over of the truck from a loading dock. The seat anchorage shall be able to withstand a force of 2 250 N at a $45^\circ \pm 5^\circ$ angle, as shown in Figure 4.

Verification of this requirement shall be by means of a type test carried out using a strap wrapped around the seat as shown in Figure 4.

The specification and marking of the operator's seat is subject to regional requirements, additional to the requirements of this part of ISO 3691. See ISO/TS 3691-7:2011.

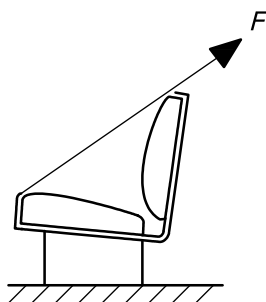

Key

F force, 2 250 N

Figure 4 — Seat anchorage pull test

4.7.5 Protection from road wheels and objects thrown up by the wheels

4.7.5.1 Ride-on trucks

In the normal operating position, the operator shall be protected against contact with the truck wheels and against objects thrown up by the wheels (e.g. mud, gravel, debris). The protection device for the steered wheels need only cover the wheels when in a straight-line position.

4.7.5.2 Pedestrian-controlled trucks

The operator in the normal operating position shall be protected against contact with the drive and stabilizing wheels. The position of these wheel protections shall be in accordance with Figure 5.

Dimensions in millimetres

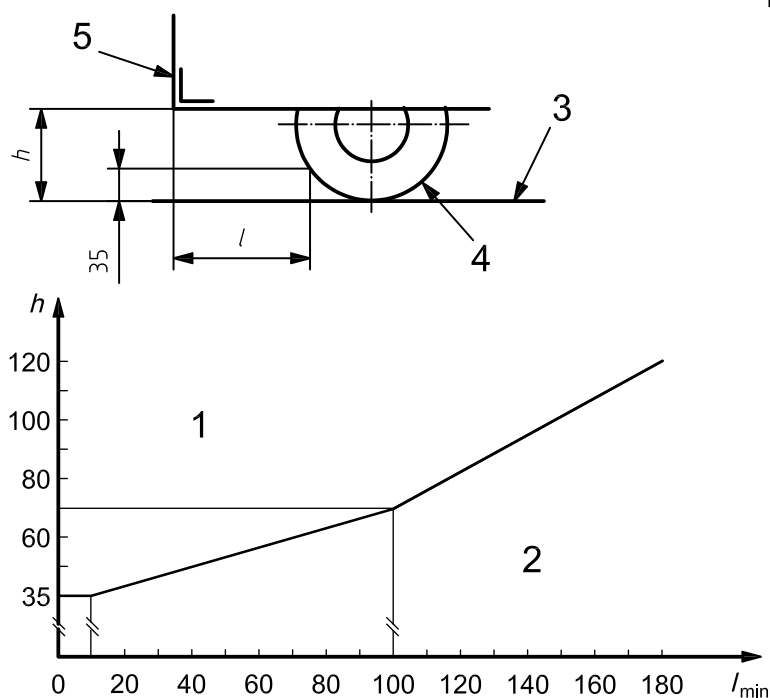

Either:

$$h < 35 \text{ mm}; l_{\min} = 10 \text{ mm}$$

Or:

$$h = 35 \text{ mm to } 70 \text{ mm}; l_{\min} = 2,57 \times h - 80 \text{ mm}$$

$$h = 70 \text{ mm to } 120 \text{ mm}; l_{\min} = 1,60 \times h - 12 \text{ mm}$$

Key

- 1 frame
- 2 foot space
- 3 ground/floor
- 4 wheel
- 5 frame edge
- h height from ground or floor to frame edge
- l horizontal distance from end of frame to point on wheel 35 mm above ground or floor

Figure 5 — Free space for operator's feet

If, for pedestrian-controlled trucks, the driving and stabilizing wheel protection specified in 4.7.5.2 cannot be complied with, a wheel guard (deflector) as shown in Figure 6 shall be installed. For castors, the deflector need only be mounted on the side on which the conditions specified in 4.7.5.2 are not met.

Dimensions in millimetres

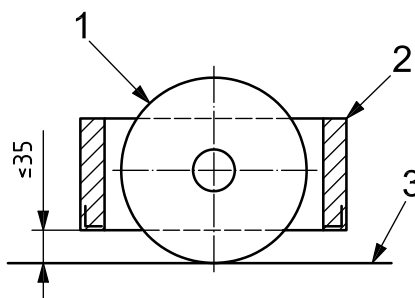

Key

- 1 wheel
- 2 deflector
- 3 ground (floor)

Figure 6 — Foot protection

4.7.6 Protection from burning

All parts of the truck within reach of the operator in the normal operating position or when the operator is entering or leaving the operating position shall be insulated or shielded so that the surface temperature, generated by heat sources in the truck, of bare metal parts does not exceed 65 °C, and that of painted or plastic parts does not exceed 83 °C. The temperature of the air at the heater outlet, where fitted, shall not exceed 60 °C.

4.7.7 Protection against crushing, shearing and trapping

4.7.7.1 General

Parts that move relative to one another and that are within reach of the operator in the normal operating position shall be adequately guarded. If hazards still exist, they shall be identified according to 6.2 and on the truck in accordance with 6.3.3.4.

Fixed guards and their mounting systems and fixed and/or removable guard systems are subject to regional requirements, additional to the requirements of this part of ISO 3691. See ISO/TS 3691-7:2011.

4.7.7.2 Minimum distances

Parts separated by the following minimum distances satisfy the adequate guarding requirements of 4.7.7.1:

- | | |
|---|--------------|
| a) places where only the operator's fingers can be trapped: | min. 25 mm; |
| b) places where only the operator's hands or feet can be trapped: | min. 50 mm; |
| c) places where the operator's arms or legs can be trapped: | min. 100 mm. |

Moving parts that need to be in contact with, or move in close proximity to, one another shall be guarded. Any openings in such guarding shall be small enough to prevent an 8 mm diameter probe from passing through them. If such hazards still exist, they shall be identified on the truck in accordance with 6.3.3.4.

4.7.7.3 Attachments

Crushing and shearing hazards to the operator in the normal operating position associated with attachments, except at the load supporting points, shall also meet the relevant requirements of 4.7.7.1. If such hazards still exist, they shall be identified according to 6.2 and on the attachment by a warning sign in accordance with 6.3.3.4.

4.7.7.4 Foot protection

Trucks with a side-facing seated or standing operator shall be so built that when travelling, the operator cannot unintentionally place his feet outside the confines of the truck; or, alternatively, the truck shall be equipped with a traction cut off (e.g. dead-man switch), enabled whenever an operator's foot is not in the safeguarded position.

4.7.8 Operator restraint

Sit-on counterbalanced lift trucks with a rated capacity up to and including 10 000 kg and sit-on, single side-loading trucks shall have a restraint device, system or enclosure intended to reduce the risk of entrapment of the operator's head and/or torso between the truck and the ground in the event of a tip-over. Such means shall not unduly restrict the operation of the truck, e.g. the operator's access, egress, and/or visibility. Warnings and instructions on the purpose, use and action to be taken in the event of a tip-over, so as to reduce the risk associated with the operator's head impacting a solid surface, shall be provided on the truck and described in the instruction handbook (see 6.2). If a restraint system with a belt is used, this system shall be in accordance with ISO 24135-1.

Operator restraint requirements for sit-on counterbalanced trucks are subject to regional requirements, additional to the requirements of this part of ISO 3691, including requirements for counterbalanced lift trucks having a centre control, sit-on, non-elevating operator and a rated capacity up to and including 10 000 kg, and sit-on, single side-loading trucks. See ISO/TS 3691-8.

4.7.9 Additional operator positions

Additional operator position(s) shall be in accordance with 4.7.1 to 4.7.8.

4.8 Stability

4.8.1 General

In order to reduce the hazards of longitudinal and lateral tip-over in the operating conditions foreseen by the manufacturer, the trucks specified below shall comply with the stability requirements given in the applicable part of ISO 22915, without permanent deformation of the structure (see 5.2):

- basic test criteria and requirements for all applicable truck types, ISO 22915-1;
- counterbalanced trucks with mast, ISO 22915-2;
- reach and straddle trucks, ISO 22915-3;
- pallet stackers, double stackers and order-picking trucks with operator position elevating up to and including 1 200 mm lift height, ISO 22915-4;
- bidirectional and multidirectional trucks, ISO 22915-7;
- industrial variable-reach trucks, ISO 22915-11;
- order-picking trucks with operator position elevating above 1 200 mm, ISO 22915-21.

NOTE At the time of publication of this part of ISO 3691, other parts of ISO 22915 were planned or under preparation, applicable to the following types of industrial trucks: counterbalanced trucks with mast handling freight containers of 6m (20 ft) length and longer; industrial variable-reach trucks handling freight containers of 6m (20ft) length and longer; rough-terrain trucks with mast, rough-terrain variable-reach trucks; counterbalanced trucks with articulated steering; pedestrian-propelled trucks; burden and personnel carriers; lateral- and front-stacking trucks with elevating operator position.

The stability of trucks lifting less than 500 mm shall be tested according to the test requirements defined for travelling by the appropriate International Standard for stability for a similar truck design equipped with a mast.

Stability requirements are subject to regional requirements, additional to the requirements of this part of ISO 3691. See ISO/TS 3691-7:2011.

4.8.2 Specific operating conditions

For specific operating conditions foreseen by the manufacturer, additional stability tests shall be carried out in accordance with the following parts of ISO 22915, as applicable:

- trucks operating in the special condition of stacking with mast tilted forward and load elevated, ISO 22915-8;
- trucks operating in the special condition of stacking with load laterally displaced by powered devices, ISO 22915-10;
- trucks operating in the special condition of offset load, offset by utilization, ISO 22915-20.

4.8.3 Levelling indicator for rough-terrain trucks

Rough-terrain trucks shall be equipped with a levelling indicator to permit the operator in the operating position to keep the truck within the tilt limitations (for longitudinal and lateral axes) foreseen by the manufacturer.

4.9 Protective devices

4.9.1 Overhead guard

4.9.1.1 General

Ride-on trucks with a maximum lift height of more than 1 800 mm above the floor shall be fitted with an overhead guard complying with ISO 6055 to protect the operator from falling objects.

Trucks with an elevating operator position up to and including 1 200 mm that feature a lift height of the load of more than 1 800 mm above the operator platform shall be fitted with an overhead guard complying with ISO 6055 to protect the operator from falling objects.

4.9.1.2 Additional fitting against falling small objects

The overhead guard specified in 4.9.1.1 shall, when handling a load above 1 800 mm lift height, be constructed in such a manner that it can be provided with an additional fitting making it possible in those special cases to increase the protection of the operator against falling small objects.

4.9.1.3 Pedestrian-controlled trucks with foldable platform

Pedestrian-controlled trucks with a foldable platform as specified in 4.7.3.3 shall be provided with means to prevent lifting over 1 800 mm from the floor when the side guards are in their protective position. This does not apply if an overhead guard as specified in 4.9.1.1 is fitted on the truck.

4.9.2 Load backrest extension

4.9.2.1 Provision for load backrest extension

Trucks fitted with fork arms with a lift height of more than 1 800 mm shall be designed so that they can be fitted with a load backrest extension.

4.9.2.2 Size of openings

Load backrest extensions, if provided, shall have height, width, and size openings sufficient to minimize the possibility of the load falling toward the mast when the mast is in a position of maximum rearward tilt.

The size of openings in the load backrest extension, if provided, shall not exceed 150 mm in one of the two dimensions.

4.9.3 Warning device

Trucks shall be equipped with an operator-controlled audible warning device.

4.9.4 Wheels with split wheel rims for inflatable tyres

When split wheel rims are used with pneumatic tyres, the truck shall be provided with means to prevent the user from separating the halves of the wheel before removing it from the axle. Information on the proper means of removing the tyre from the wheel shall be provided in the instruction handbook (see 6.2).

4.9.5 Traction battery compartment

4.9.5.1 Unauthorized access

On trucks with a nominal battery voltage exceeding 120 V d.c., if a lockable cover is not present on the battery enclosure, facilities shall be provided to enable the battery compartment to be secured so as to prevent unauthorized access to the battery.

4.9.5.2 Metal cover

A metal cover for a battery compartment or battery enclosure shall have either

- a) sufficient strength and rigidity, in conjunction with an air spacing of at least 30 mm provided between it and the battery terminals, so that the battery terminals are not short-circuited when a 980 N force is applied to any area 300 mm × 300 mm of the cover, or
- b) an air space reduced to a minimum of 10 mm, provided covers or live parts of the battery are insulated in such a way that disintegration and/or displacement of the insulation is prevented.

4.9.5.3 Non-metallic cover

For non-metallic covers of battery compartments, the following applies.

- a) The cover shall have a burn rating of V0 or V1 in accordance with IEC 60695-11-10.
- b) The cover shall comply with an impact test of 136 J, the impact being produced by dropping a steel sphere having a diameter of 100 mm and mass of 4,11 kg from a height of 3,3 m. If the battery is located under an overhead guard, the impact may be reduced to 68 J, produced by dropping a steel sphere having a diameter of 100 mm and mass of 4,11 kg from a height of 1,65 m. There shall be no live parts exposed or impact that causes physical damage to the battery.
- c) If metallic parts project into the battery compartment, then 4.9.5.2 applies.

4.9.5.4 Ventilation

The compartment and enclosure that houses a battery shall be provided with means for ventilation that reduce the likelihood of accumulation of explosive hydrogen-air mixture during truck operation.

When openings are positioned such that gases can escape freely, these shall be located away from the operator's position. Ventilation openings are usually satisfactory if they provide a cross-section, in square millimetres, equal to half the number of cells, multiplied by the rated capacity in Ampere-hours. This level of ventilation is not intended to cover the charging condition.

4.9.5.5 Resistance to electrolyte

The battery enclosure, in accordance with ISO 20898, shall be resistant to the chemical effects of the electrolyte.

4.9.6 Battery-restraint devices

On battery-powered trucks, means shall be provided to retain the battery from moving more than 15 mm in a horizontal direction.

In addition, on ride-on type trucks — where the displacement of the traction battery may pose a risk of injury to the operator due to a tip-over — a battery-restraint device(s) shall restrict the battery displacement to no more than 100 mm into the space normally occupied by the operator or from moving more than 100 mm in a lateral direction beyond the limits of the battery compartment. A tip-over may be simulated by allowing a static truck to fall free from its critical balance point impacting on a horizontal plane. A complete truck is not required for

this test, but all battery compartment related parts shall be fitted. The movement of the battery shall not interfere with the operator's egress from the truck.

The battery housing shall be constructed, located and the battery installed so as to avoid electrolyte being spilled onto the operator in the event of tip-over and/or to avoid the accumulation of vapours in places occupied by the operator.

The battery cover, if any, of a compartment that is an integral part of the truck, or a separate enclosure such as a tray and cover, shall be secured.

4.9.7 Starter battery requirements

The starter battery on engine-powered trucks shall be restrained from movement.

4.9.8 Handling of batteries

Battery-powered trucks should be designed such that batteries with a mass in excess of 25 kg can be easily removed using a means which supports the weight of the battery during removal, e.g. an opening for slings in the overhead guard or rollers.

4.10 Visibility and lighting

4.10.1 Visibility

Requirements for all-round visibility from unladen trucks up to and including 10 000 kg rated capacity shall be in accordance with ISO 13564-1.

For visibility with load, see 6.2.2, considering that, if direct visibility is limited by the load, aids can be used.

Visibility requirements are subject to regional requirements, additional to the requirements of this part of ISO 3691. See ISO/TS 3691-7:2011.

NOTE Visibility requirements for trucks over 10 000 kg were being developed at the time of publication of this part of ISO 3691.

4.10.2 Lighting

Ride-on trucks shall be so designed that it is possible, referring to the manufacturer's instructions, to equip them with travel lights, working lights and signal lights.

4.11 Environmental conditions

4.11.1 Operator's cab

4.11.1.1 General

If a cab is fitted in lieu of an overhead guard, it shall comply with 4.9.1.

4.11.1.2 Fire resistance

All material and components of the cab shall be fire-resistant, with a maximum burning speed of 250 mm/min when the standard test piece is tested in accordance with ISO 3795.

4.11.1.3 Ventilation

If a totally enclosed cab is fitted, provision shall be made for efficient ventilation.

4.11.1.4 Heater, demister and defroster

If a totally enclosed cab is fitted with a heater/demister, the air intake should be connected to a fresh air inlet; recycling of the air is permissible. The heater shall be securely fixed. The heater shall be so designed that the requirements of 4.7.6 can be met. A demist/defrost capability shall be provided for the windscreen and rear window.

4.11.1.5 Wipers and washers

Windscreen wiper(s) and washer(s) shall be fitted to allow the operator a clear view of the operating area. Wiper(s) and washer(s) for the rear window may be omitted if the truck is driven predominantly in the forward direction, e.g. tow tractors. Wiper(s) and washer(s) may be omitted entirely if the truck only operates within an enclosed area. If glass is used in the window apertures, it shall be toughened or laminated.

4.11.1.6 Access and emergency exit

The cab shall have an access and an emergency exit complying with ISO 2867. The emergency exit, which may be a window, shall allow escape in a different direction than that of the normal exit.

4.11.1.7 Storage of instruction handbook

Provision shall be made for the storage of the instruction handbook (see 6.2) so that it does not obstruct the normal operating position.

4.11.1.8 Additional operator's position

If an additional operator's position is equipped within a cab, it shall meet the requirements of 4.11.1.1 to 4.11.1.6.

4.11.2 Noise emissions

Noise emissions are subject to regional requirements. See ISO/TS 3691-7:2011.

4.11.3 Vibration

Whole-body vibrations transmitted to the operator are subject to regional requirements. See ISO/TS 3691-7:2011.

4.11.4 Electromagnetic compatibility (EMC)

EMC is subject to regional requirements. See ISO/TS 3691-7:2011 and ISO/TS 3691-8.

4.11.5 Transport

4.11.5.1 Location for lifting and/or slinging points

When a truck can be lifted without disassembling, locations for lifting and/or slinging points shall be provided and shall be indicated on the truck and/or in the instruction handbook (see 6.2).

When individual assemblies of the truck can be removed for normal operation and/or transport, then lifting and/or slinging points shall be provided and these shall be indicated on the assemblies and/or in the instruction handbook.

Slinging points for transportation of the truck shall be arranged such that there is no possibility of sudden movement.

4.11.5.2 Tie-down points

Tie-down points for transportation of the assembled truck shall be provided and indicated on the truck or in the instruction handbook (see 6.2).

4.11.5.3 Slinging of removable attachments

Locations for the slinging of a removable attachment shall be provided and shall be indicated on the attachment (see 6.3.1.2) and/or in the instruction handbook.

Slinging points for transportation of the attachment shall be arranged such that there is no possibility of sudden movement.

4.12 Devices for towing

Trucks used for towing trailers shall be fitted with towing or coupling devices designed, constructed and arranged to reduce hazards of connection and disconnection and to prevent accidental disconnection during use.

5 Verification of safety requirements and/or protective measures

5.1 General

The manufacturer shall have verification that the safety requirements and/or protective measures given in Clause 4 have been incorporated into the design and manufacture of the truck. Either one or a combination of the following shall be used to achieve verification:

- a) by design, e.g. verification of drawings and documents, or calculation;
- b) by measurement, e.g. tests of travelling and lowering speed or lift and tilt leakage;
- c) by visual examination, e.g. no permanent deformation after tests, verification of the marking of the truck;
- d) by further testing.

5.2 Structural tests

These tests are to be performed on a sample that is representative of series production. The structural components of the truck and its attachments shall carry static loads of $1,33 Q_1$ and $1,33 Q_2$ for 15 min each, where

Q_1 is the rated capacity at the standard lift height and standard load centre distance in accordance with the information on the capacity plate;

Q_2 is the actual capacity at maximum lift height in accordance with the information on the capacity plate.

The truck shall be on substantially level ground with the mast in the substantially vertical position and may be anchored to prevent tip-over.

The loads may be applied at the corresponding height by means independent of the truck. The test shall not result in any visual permanent deformation or damage.

5.3 Functional verification

Functional verification shall be carried out on each truck to verify that it is able to perform the tasks for which it was designed. These tests shall be done according to the manufacturer's instructions. They shall be performed by trained persons either operating and testing the truck according to the manufacturer's instructions or simulating these tests by any method giving an equivalent effect and producing substantially the same result.

Each truck shall be inspected to ensure that the travelling, braking, steering, load-handling controls and combined functions, if any, are appropriately identified and operate correctly. The correct operation of warning devices, safety devices and lighting, if any, shall also be checked.

6 Information for use

6.1 General

Each truck and removable attachment shall be supplied to the user with an instruction handbook(s), covering operating and regular servicing and addressing all identified hazards, printed in the language(s) of the country in which the truck is to be used, where required by national law. See also ISO 12100:2010, 6.4.5.

There is no need for the workshop and parts handbooks intended for use by specialized personnel employed by the manufacturer or his authorized representative to be supplied with each truck, and these can be printed in the language of the country where the truck is to be used, as required by national law. In other cases, the instructions shall be in a language agreed between the truck supplier and purchaser.

6.2 Instruction handbook

6.2.1 Truck/attachments

The instruction handbook(s) shall include, as applicable, at least the following information:

- a) name and address of the manufacturer or authorized representative;
- b) designation of type, e.g. counterbalanced, side-loading truck;
- c) description of the truck and accessories;
- d) attachments supplied with the truck and their assembly precautions;
- e) details of use of a removable load backrest extension;
- f) details for the installation of a fire extinguisher, if required by the application of the truck;
- g) admissible wheel rims and tyres with inflation pressures for pneumatic tyres;
- h) description of safety devices and warning labels.

Instructions on truck/attachments are subject to regional requirements, additional to the requirements of this part of ISO 3691. See ISO/TS 3691-7:2011.

6.2.2 Operation of truck

The instruction handbook(s) shall include, as applicable, at least the following information:

- a) intended uses of the truck and attachments, and examples of hazardous misuse;

- b) training requirements for the operator;
- c) function of operating controls and displays;
- d) pre-shift checks before the truck is put into operation;
- e) instructions for adjustment of the operator's seat;
- f) instructions for operation with/without cab, with/without doors;
- g) instructions for access and egress;
- h) instructions for safe handling by the operator, e.g. when changing attachments or moving fork arms;
- i) requirements of the ground/floor where the truck is to be used;
- j) instructions for starting, driving and stopping the truck;
- k) instructions for handling loads, warning about the hazards due to the action of wind forces;
- l) instructions when operating on a gradient;
- m) instructions for towing the truck;
- n) instructions for parking the truck;
- o) warning of risks during the use of the truck and its attachments, including crushing and shearing hazards;
- p) climatic conditions in which the truck is designed to operate;
- q) information about the direction of turning of the truck in relation to rotation of the steering wheel for end-controlled trucks;
- r) information about operating the truck with loads causing insufficient visibility;
- s) information on the use of any visual aid that may be provided;
- t) information and conditions for the use of the drawbar;
- u) instructions when operating a rear touch device;
- v) information or instructions on action to be taken in the event of a malfunction;
- w) information for operation of the truck by a remote control device, e.g. visibility;
- x) the normal operating conditions as defined by the manufacturer, i.e. those for which the truck has been designed and the manner in which the truck will be used;
- y) instructions on the use of the operator-restraint device, system or enclosure, and guidance on the operator's behaviour in the event of a tip-over;
- z) information about lighting of the working area;
- aa) the procedure for movement of inoperative trucks;
- bb) instructions against operating truck with guarding removed;
- cc) lift height for travelling;

- dd) crushing and shearing hazards for the operator of pedestrian-controlled trucks featuring foldable platforms and reach trucks, between parts of the environment and the truck during travelling forward;
- ee) instructions to the operator of a stand-on end-control truck to step off and away from the truck in the event of a tip-over or off-dock accident;
- ff) information and instructions for using attachments, e.g. load bearing clamp.

Instructions on the operation of the truck are subject to regional requirements, additional to the requirements of this part of ISO 3691. See ISO/TS 3691-7:2011.

6.2.3 Details for battery-powered trucks

The instruction handbook(s) shall include, as applicable, at least the following information:

- a) specification of approved batteries and on-board battery chargers;
- b) procedure for safe handling of batteries, including installation, removal and secure mounting on the truck;
- c) warning of risks of accumulation of hydrogen under covers;
- d) battery charging procedures and instructions;
- e) service mass of battery and ballast when required.

6.2.4 Details for internal-combustion-engine powered trucks

The instruction handbook(s) shall include at least the following information:

- a) approved fuels;
- b) procedure for safe handling of fuels;
- c) procedure for refuelling;
- d) warning of the effect of exhaust emissions in confined spaces;
- e) warning of the effect of exhaust emissions for the operator.

6.2.5 Service and maintenance

The instruction handbook(s) shall include, as applicable, at least the following information:

- a) training and qualifications needed for service and maintenance staff;
- b) safe procedure for the identification, detection and correction of faults;
- c) instructions for changing tyres or wheels;
- d) instructions for verification that markings, e.g. decals, are in place and legible;
- e) instructions for de-energizing of stored energy components;
- f) access to maintenance while working at height;
- g) servicing operations for which no specific skills are required;
- h) use of approved spare parts;

- i) drawings and diagrams necessary for truck service and maintenance;
- j) instructions for disposing of waste material (e.g. oils and battery);
- k) type and frequency of inspections and maintenance operations, with particular attention to the replacement and durability of wear and serviceable parts, emissions, and to the user's logbook (e.g. filter, brakes, chains, hydraulic hoses);
- l) instructions for removing and reattaching guarding;
- m) instructions for regular verification of seat belt related to
 - 1) cut or frayed straps,
 - 2) worn or damaged hardware, including anchor points,
 - 3) buckle or retractor malfunction,
 - 4) loose stitching.

6.2.6 Transportation, commissioning and storage

The instruction handbook(s) shall include, as applicable, at least the following information:

- a) mass and overall dimensions of the truck and dismantled parts for transport, commissioning and storage;
- b) procedures for transporting, including loading and unloading;
- c) procedure for truck reassembly and mounting of attachments;
- d) functional tests on completion of commissioning;
- e) procedure for movement of inoperative trucks;
- f) procedure for prolonged shut down and storage of trucks.

Transportation, commissioning and storage are subject to regional requirements, additional to the requirements of this part of ISO 3691. See ISO/TS 3691-7.

6.2.7 Truck modification

6.2.7.1 Unauthorized truck modification is not permitted. The text of 6.2.7.3 shall be included in the instruction handbook and the workshop handbook.

6.2.7.2 Except where provided in 6.2.7.3, no modifications or alterations to a powered industrial truck, which could affect, for example, capacity, stability or safety requirements of the truck, shall be made without the prior written approval of the original truck manufacturer, its authorized representative, or a successor thereof. This includes changes affecting, for example, braking, steering, visibility and the addition of removable attachments. When the manufacturer or his successor approves a modification or alteration, the manufacturer or successor shall also make and approve appropriate changes to the capacity plate, decals, tags and operation and maintenance handbooks.

6.2.7.3 Only in the event that the truck manufacturer is no longer in business and there is no successor in the interest to the business, may the user arrange for a modification or alteration to a powered industrial truck, provided, however, that the user

- a) arranges for the modification or alteration to be designed, tested and implemented by an engineer(s) expert in industrial trucks and their safety,

- b) maintains a permanent record of the design, test(s) and implementation of the modification or alteration,
- c) approves and makes appropriate changes to the capacity plate(s), decals, tags and instruction handbook, and
- d) affixes a permanent and readily visible label to the truck stating the manner in which the truck has been modified or altered, together with the date of the modification or alteration and the name and address of the organization that accomplished those tasks.

6.3 Marking

6.3.1 Information plates

6.3.1.1 Trucks

Trucks shall be marked legibly and indelibly (e.g. weather-proofed, profiled letters) with at least the following details:

- a) name and address of the manufacturer or his authorized representative;
- b) designation of series or type and compliance with the requirements of this part of ISO 3691;
- c) serial number and year of manufacture;
- d) unladen mass of the truck in working order and without removable attachments, and without battery in the case of battery-powered trucks, but with fork arms or integral attachments, the actual mass being permitted to vary from the stated mass by up to $\pm 5\%$ or 1 000 kg, whichever is the lower of the two;
- e) actual capacity at maximum lift height with load centre distance; where a secondary lift is fitted to a truck, the capacity at maximum lift shall be determined with the secondary mast fully elevated;
- f) actual capacities at other lift heights and load centre distances, if applicable;
- g) actual capacity with each removable attachment fitted at the manufacturer's authorized lift height(s) and load centre(s), these actual capacities being easily readable by the operator in the normal operating position;
- h) on battery-powered trucks, the authorized maximum and minimum battery mass and the system voltage;
- i) if fitted, the maximum supporting force on the towing point connection, in newtons;
- j) if fitted, the drawbar pull on the towing point connection, in newtons;
- k) the nominal power in kilowatts, e.g. marked on the engine or electric motor.

Marking requirements are subject to regional requirements, additional to the requirements of this part of ISO 3691. See ISO/TS 3691-7:2011 and ISO/TS 3691-8.

6.3.1.2 Removable attachments

Removable attachments shall be marked legibly and indelibly (e.g. weather-proofed, profiled letters) with at least the following details:

- a) name and address of the attachment manufacturer or his authorized representative;
- b) model or type;
- c) serial number and year of manufacture;

- d) mass of attachment, which may vary from the stated figure by up to $\pm 5\%$ or 200 kg, whichever is the lower of the two;
- e) distance of the centre of gravity of the attachment from its mounting face on the truck;
- f) rated capacity;
- g) in the case of hydraulically or pneumatically operated attachments, the maximum operating pressure recommended by the attachment manufacturer;
- h) load centre, if applicable;
- i) lost load centre distance;
- j) the instruction "The capacity of the truck and attachment combination shall be complied with".

6.3.1.3 Tractors

Tractors shall be marked legibly and indelibly (e.g. weather-proofed, profiled letters) with at least the following details:

- a) name and address of the manufacturer or the authorized representative;
- b) designation of series or type;
- c) unladen mass of the tractor in working order without battery for battery-powered tractors; the mass may vary from the figure shown by up to $\pm 5\%$ or 1 000 kg, whichever is the lower;
- d) serial number and year of manufacture;
- e) on battery-powered tractors, the authorized minimum and maximum battery mass and the system of voltage;
- f) the nominal power in kilowatts, e.g. marked on the engine or electric motor;
- g) the maximum supporting force on the tow-hook, in newtons;
- h) the drawbar pull, in newtons, and the period of time during which this pull can be exerted.

6.3.1.4 Marking of controls

Controls shall be legibly and indelibly marked (e.g. weather-proofed, profiled letters) with graphic symbols indicating the function(s), except where these are obvious, e.g. accelerator pedal. Each symbol shall be affixed on, or in close proximity to, the control to which it applies. Control symbols shall comply with ISO 3287, for existing symbols.

6.3.2 Information plate for trucks operating in special conditions

If a truck is designed to operate in special conditions (see 4.1.1. and 4.8.2), the manufacturer shall provide, where appropriate, and in addition to the information provided in the instruction handbook, an information plate on the truck identifying those special conditions of use, including capacity if different from the capacity during normal operation (see 4.1.2).

6.3.3 Other information

6.3.3.1 Marking for slinging of trucks

Locations for slinging shall be clearly indicated on the truck or shall be declared in the instruction handbook (see 6.2).

6.3.3.2 Pneumatic tyre inflation pressure

The specified inflation pressures shall be clearly indicated on the truck.

6.3.3.3 Filling points

Filling points for fuel and hydraulic fluid shall be clearly indicated on the truck in accordance with ISO 3287.

6.3.3.4 Warning signs

Symbols giving warnings of remaining hazards shall be affixed to the truck and attachments on, or in close proximity to, the hazard concerned. On stored energy devices (see 4.1.6), a warning label and the method for removing any stored energy shall be affixed to that component and noted in the service handbook. Warnings shall be in accordance with ISO 15870.

6.3.4 Languages

If any of the information in 6.3.1 to 6.3.3 is in words, it shall be written in the language(s) of the country in which the truck is to be used, in accordance with national law. In other cases, the instructions shall be in a language agreed between the truck supplier and purchaser.

6.3.5 Operator restraint

Information or symbols giving instructions for the use of the operator restraint system or enclosure shall be easily readable by the operator in the normal operating position.

Annex A (normative)

Determination of driving direction and rated capacity

A.1 Forward-driving direction

The forward-driving or forward direction is dependent on the type of truck.

- a) For sit-on trucks where the operator is facing the line of travel, load leading is the forward direction.
- b) For sit-on trucks where the operator is facing approximately at a right angle to the line of travel, load trailing is the forward direction.
- c) For side-loading trucks (one side only) where the operator is facing towards the line of travel, the direction in which the operator is facing is the forward direction.
- d) For side-loading trucks (one side only) where the operator is facing approximately at right angles to the line of travel, the forward direction is the end at which the operator is positioned.
- e) For trucks with an elevated operator position, the forward direction is the direction in which the operator is oriented when facing the travel controls.
- f) For pedestrian-controlled trucks and low-lift order-picking trucks, load trailing is the forward direction.
- g) For stand-on, end-controlled trucks where the operator is facing the line of travel, load leading is the forward direction.
- h) For stand-on, end-controlled trucks where the operator is facing at a right angle to the line of travel, the travel direction is defined only by load trailing or load leading.

A.2 Rated capacity

A.2.1 Specification

A.2.1.1 High-lift trucks with masts

For the rated load, Q , the following conditions apply (see Figure A.1):

- load centre of gravity, G , positioned at the standard load centre distance, D (see A.2.3);
- load Q vertically lifted to the standard lift height, H (see A.2.2);
- a truck equipped with a two-stage mast that has a maximum lift equal to the standard lift height.

When the truck does not utilize a two-stage mast, it should be given a rated capacity at the standard lift height as if the mast were available.

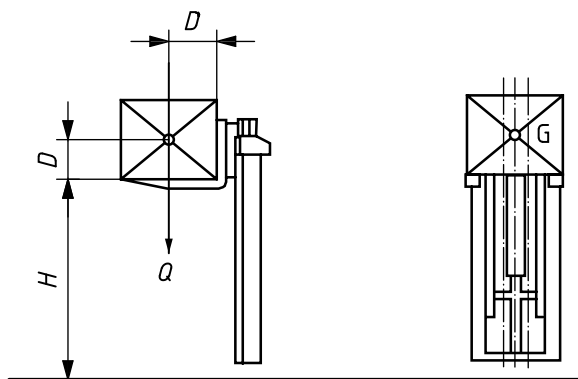

Key

- D standard load centre distance
- G load centre of gravity, positioned in the longitudinal plane of symmetry between the mast uprights
- H standard lift height
- Q rated load

Figure A.1 — Rated load configuration

A.2.1.2 Pedestrian-controlled, pallet-stacker trucks

For the rated load, Q , the following conditions apply (see Figure A.1):

- load centre of gravity, G , positioned at the standard load centre distance, D (see A.2.3);
- load Q vertically stacked to the standard lift height, H (see A.2.2).

A.2.1.3 Pedestrian-controlled scissor-lift pallet trucks

For these trucks, the maximum load, given by the manufacturer, expressed in kilograms and uniformly distributed over the length of the fork arms, is the load that the truck is capable of carrying and lifting in normal operation.

A.2.1.4 Low-lift-height and fixed-platform trucks

For these trucks, the maximum load, given by the manufacturer, expressed in kilograms and uniformly distributed over the load-carrying platform or device is the load that the truck is capable of carrying and — if applicable — lifting in normal operation.

A.2.1.5 Removable attachments

For such attachments, the maximum load, in kilograms, at a specified load centre that the attachment is capable of handling in normal operation is as specified by the attachment manufacturer.

A.2.2 Standard lift height, H

Standard lift height values, expressed in millimetres, are measured from the ground to the upper face of the fork blades or lifting platform, and are as follows for the trucks covered by this part of ISO 3691:

- for pallet-stacking trucks and high-lift platform trucks having a width across fork arms or platform up to and including 690 mm, and for counterbalanced trucks below 1 000 kg rated load, $H = 2\,500$ mm;
- for all other types of trucks, up to and including 10 000 kg rated load, $H = 3\,300$ mm;
- for all other types of trucks, above 10 000 kg rated load, $H = 5\,000$ mm.

A.2.3 Standard load centre distance, D

Distance D , expressed in millimetres, is measured from the centre of gravity, G , of the load measured horizontally to the front face of the fork arm shank and vertically to the upper face of the fork arm blade.

— For counterbalanced trucks, the values of D are according to Table A.1.

Table A.1

Rated load, Q kg		Standard load centre distance, D mm				
		400	500	600	900	1 200
0	< 1 000	X		X ^a		
≥ 1 000	< 5 000		X	X ^b		
≥ 5 000	≤ 10 000			X	X	
> 10 000	< 20 000			X	X	X
≥ 20 000	< 25 000				X	X
≥ 25 000						X
^a 600 mm is used in the USA. ^b 600 mm is used in the USA, Asia and Australia.						

- For single side-loading trucks and lateral- and front-stacking trucks, D is as specified by the manufacturer.
- For trucks where the load centre distances differ from those specified in Table A.1 for special applications, the respective rated capacity should be defined.
- For all other types of trucks, up to and including 10 000 kg rated load, $D = 600$ mm.

NOTE Some Asian countries use a load centre distance of 500 mm for reach trucks and high-lift order-picking trucks with a rated capacity up to and including 3 000 kg.

A.3 Rated drawbar pull of tractors

The horizontal drawbar pull at the coupling, in newtons, given by the manufacturer, is that which the industrial tractor can develop at a specified coupling height while travelling on a smooth, dry and horizontal concrete surface as follows:

- for tractors powered by an internal combustion engine, while moving at a uniform speed of not less than 10 % of the rated no-load speed;
- for battery-powered tractors, that which can be sustained continuously for a period of 1 h.

For ride-on tractors the rated drawbar pull should be established using an operator mass of 90 kg (ballasted accordingly).

The requirements for the quality of the driving surface can differ for the floor used indoors and outdoors. This floor quality depends on the operating conditions of the tractor, and these conditions should be specified in the instruction handbook [see 6.2.2 i)].

Annex B (informative)

List of significant hazards

This list contains all the significant hazards, hazardous situations and events, as far as they are dealt with in this part of ISO 3691, identified by risk assessment of industrial trucks and which require action to eliminate or reduce the risk. See Table B.1.

NOTE The structure of the table is based on that of ISO 14121-1:2007, Table A.1⁴⁾. The order of lines within a group corresponds to the truck functionalities.

Table B.1 — List of significant hazards

No.	Type or group/origin	Potential consequences	Corresponding requirement	
1	Mechanical hazards			
	— Acceleration, deceleration (kinetic energy)	— Being run over	4.1.4	Electrical requirements
		— Crushing	4.1.6	Stored energy components
	— Machinery mobility	— Drawing-in or trapping	4.2	Starting/moving
	— Moving elements		4.3	Brakes
	— Rotating elements	— Impact	4.4	Manual control actuators
			4.6.2.2	Failure of lifting/lowering mechanism
			4.6.2.3	Lowering speed
			4.6.3	Hydraulic lifting and tilting system
			4.6.4.3	Failure of energy supply to hydraulic circuit
			4.6.4.4	Fluid purification
			4.6.5	Load-handling and stacking attachments
			4.7.3	Platform
			4.7.4	Operator's seat
			4.7.5.2	Protection from road wheels/Pedestrian-controlled trucks
			4.9.3	Warning device
			4.9.6	Battery-restraint devices
			4.9.7	Starter battery requirements
			4.7.8	Operator restraint
			5	Verification of safety requirements and/or protective measures
			6	Information for use

4) ISO 14121-1:2007, *Safety of machinery — Risk assessment — Part 1: Principles*.

Table B.1 (continued)

No.	Type or group/origin	Potential consequences	Corresponding requirement	
1	Mechanical hazards			
	<ul style="list-style-type: none"> — Angular parts — Approach of a moving element to a fixed part — Cutting parts — Sharp edges 	<ul style="list-style-type: none"> — Crushing — Cutting or severing — Drawing-in or trapping — Entanglement — Shearing — Stabbing or puncture 	<ul style="list-style-type: none"> 4.1.5 4.1.6 4.2 4.4.2.6 4.4.2.7 4.5.3 4.7 4.7.5 4.7.7 4.7.9 4.9.6 4.12 6 	<ul style="list-style-type: none"> Edges or angles Stored energy components Starting/moving/Travel controls/Pedestrian-controlled trucks Additional operation from outside the truck Additional operation from alongside pedestrian-controlled and stand-on trucks (coasting) Access to engine and other compartments Operator positions Protection from road wheels and objects thrown up by the wheels Protection against crushing, shearing and trapping Additional operator positions Battery-restraint devices Devices for towing Information for use
	<ul style="list-style-type: none"> — Elastic elements 	<ul style="list-style-type: none"> — Crushing — Impact — Cutting or severing — Shearing — Stabbing or puncture 	<ul style="list-style-type: none"> 4.1.6 4.9.4 6 	<ul style="list-style-type: none"> Stored energy components Wheels with split wheel rims for inflatable tyres Information for use
	<ul style="list-style-type: none"> — Falling objects 	<ul style="list-style-type: none"> — Crushing — Impact 	<ul style="list-style-type: none"> 4.4.4 4.6 4.8 4.9.1 4.9.2 4.11.1.1 4.11.5 5 6 	<ul style="list-style-type: none"> Load-handling controls Systems for lifting and tilting Stability Overhead guard Load backrest extension Operator's cab/General Transport Verification of safety requirements and/or protective measures Information for use
	<ul style="list-style-type: none"> — Gravity (stored energy) 	<ul style="list-style-type: none"> — Crushing — Impact 	<ul style="list-style-type: none"> 4.4.4 4.6 4.9.1 4.9.2 4.11.1.1 5 6 	<ul style="list-style-type: none"> Load-handling controls Systems for lifting and tilting Overhead guard Load backrest extension Operator's cab/General Verification of safety requirements and/or protective measures Information for use

Table B.1 (continued)

No.	Type or group/origin	Potential consequences	Corresponding requirement	
1	Mechanical hazards			
	— Height from the ground	<ul style="list-style-type: none"> — Being thrown — Crushing — Drawing-in or trapping — Impact — Slipping, tripping and falling 	<ul style="list-style-type: none"> 4.6 4.7.1 4.7.2 4.7.3 4.8 5 6 	<ul style="list-style-type: none"> Systems for lifting and tilting Operator position/Dimension Operator access and egress Platforms Stability Verification of safety requirements and/or protective measures Information for use
	— High pressure	— Injection	<ul style="list-style-type: none"> 4.1.6 4.5.4 4.6.4 5 6 	<ul style="list-style-type: none"> Stored energy components Liquefied petroleum gas (LPG)-powered trucks Hydraulic systems Verification of safety requirements and/or protective measures Information for use
	— Rough, slippery surface	— Slipping, tripping and falling	<ul style="list-style-type: none"> 4.7.2.2 4.7.2.3 	<ul style="list-style-type: none"> Steps Compartment floors
	— Stability	<ul style="list-style-type: none"> — Being thrown — Crushing — Impact 	<ul style="list-style-type: none"> 4.4.4 4.6 4.8 4.11.5 5 6 	<ul style="list-style-type: none"> Load-handling controls Systems for lifting and tilting Stability Transport Verification of safety requirements and/or protective measures Information for use
2	Electrical hazards			
	<ul style="list-style-type: none"> — Arc — Electromagnetic phenomena — Electrostatic phenomena — Live parts — Not enough distance to live parts under high voltage — Overload — Parts which have become live under fault conditions — Short-circuit — Thermal radiation 	<ul style="list-style-type: none"> — Burn — Chemical effects — Electrocution — Falling, being thrown — Fire — Projection of molten particles — Shock 	<ul style="list-style-type: none"> 4.1.4 4.9.5.1 4.9.5.2 4.11.4 5 6 	<ul style="list-style-type: none"> Electrical requirements Traction battery compartment/unauthorized access Metal cover Electromagnetic compatibility Verification of safety requirements and/or protective measures Information for use

Table B.1 (continued)

No.	Type or group/origin	Potential consequences	Corresponding requirement	
3	Thermal hazards			
	<ul style="list-style-type: none"> — Explosion — Flame — Objects or materials with a high or low temperature — Radiation from heat sources 	<ul style="list-style-type: none"> — Burn — Dehydration — Discomfort — Frostbite — Injuries by the radiation of heat sources — Scald 	<ul style="list-style-type: none"> 4.1.2 4.1.4 4.3 4.5.1 4.5.2 4.5.4 4.7.6 4.9.5 4.11.1.2 4.11.1.4 5 6 	<ul style="list-style-type: none"> Normal climatic conditions Electrical requirements Brakes Exhaust and cooling systems Fuel tank Liquefied petroleum gas (LPG)-powered trucks Protection from burning Traction battery compartment Operator's cab/Fire resistance Heater, demister and defroster Verification of safety requirements and/or protective measures Information for use
4	Noise hazards			
	<ul style="list-style-type: none"> — Exhausting system — Moving parts 	<ul style="list-style-type: none"> — Discomfort — Loss of awareness — Loss of balance — Permanent hearing loss — Stress — Tinnitus — Tiredness 	<ul style="list-style-type: none"> 4.11.2 	<ul style="list-style-type: none"> Noise emissions
5	Vibration hazards			
	<ul style="list-style-type: none"> — Mobile equipment 	<ul style="list-style-type: none"> — Discomfort — Low-back morbidity — Neurological disorder — Osteo-articular disorder — Trauma of the spine — Vascular disorder 	<ul style="list-style-type: none"> 4.11.3 	<ul style="list-style-type: none"> Vibration
6	Radiation hazards			
	No origin of these kinds of hazards in industrial trucks covered by this part of ISO 3691.			

Table B.1 (continued)

No.	Type or group/origin	Potential consequences	Corresponding requirement	
7	Material/substance hazards			
	<ul style="list-style-type: none"> — Combustible — Explosive — Flammable — Fluid — Fume — Gas 	<ul style="list-style-type: none"> — Breathing difficulties, suffocation — Cancer — Corrosion — Effects on reproductive capability — Explosion — Fire — Infection — Mutation — Poisoning — Sensitization 	<ul style="list-style-type: none"> 4.1.4 4.5.2.1 4.5.2.2 4.5.4 4.9.5.4 4.11.1.3 6 	<ul style="list-style-type: none"> Electrical requirements Tank isolation Fuel spillage Liquefied petroleum gas (LPG)-powered trucks Traction battery compartment/Ventilation Operator's cab/Ventilation Information for use
8	Ergonomic hazards			
	<ul style="list-style-type: none"> — Access — Design or location of indicators and visual display units — Design, location or identification of control devices — Effort — Local lighting — Mental overload/underload — Posture — Repetitive activity — Visibility 	<ul style="list-style-type: none"> — Discomfort — Fatigue — Musculoskeletal disorder — Stress Any other (e.g. mechanical, electrical) as a consequence of human error 	<ul style="list-style-type: none"> 4.1.2 4.1.4 4.4 4.5.1 4.7.1 4.7.2 4.7.3 4.7.4 4.10 4.11.1 6 	<ul style="list-style-type: none"> Normal climatic conditions Electrical requirements Manual control actuators Exhaust and cooling system Operator position/Dimensions Operator access and egress Platform Operator's seat Visibility/Lighting Operator's cab Information for use
9	Hazards associated with environment in which the machine is used			
	<ul style="list-style-type: none"> — Dust and fog — Electromagnetic disturbance — Lightning — Moisture — Temperature — Water — Lack of oxygen 	<ul style="list-style-type: none"> — Burn — Slight disease — Slipping, falling — Suffocation Any other as a consequence of the effect caused by the sources of the hazards on the machine or parts of the machine 	<ul style="list-style-type: none"> 4.1.2 4.10 6 	<ul style="list-style-type: none"> Normal climatic conditions Visibility/Lighting Information for use
10	Combination of hazards			
	E.g. repetitive activity + effort + high environmental temperature	E.g. dehydration, loss of awareness, heat stroke	<ul style="list-style-type: none"> 4.1.2 6 	<ul style="list-style-type: none"> Normal climatic conditions Information for use

British Standards Institution (BSI)

BSI is the national body responsible for preparing British Standards and other standards-related publications, information and services.

BSI is incorporated by Royal Charter. British Standards and other standardization products are published by BSI Standards Limited.

About us

We bring together business, industry, government, consumers, innovators and others to shape their combined experience and expertise into standards-based solutions.

The knowledge embodied in our standards has been carefully assembled in a dependable format and refined through our open consultation process. Organizations of all sizes and across all sectors choose standards to help them achieve their goals.

Information on standards

We can provide you with the knowledge that your organization needs to succeed. Find out more about British Standards by visiting our website at bsigroup.com/standards or contacting our Customer Services team or Knowledge Centre.

Buying standards

You can buy and download PDF versions of BSI publications, including British and adopted European and international standards, through our website at bsigroup.com/shop, where hard copies can also be purchased.

If you need international and foreign standards from other Standards Development Organizations, hard copies can be ordered from our Customer Services team.

Copyright in BSI publications

All the content in BSI publications, including British Standards, is the property of and copyrighted by BSI or some person or entity that owns copyright in the information used (such as the international standardization bodies) and has formally licensed such information to BSI for commercial publication and use.

Save for the provisions below, you may not transfer, share or disseminate any portion of the standard to any other person. You may not adapt, distribute, commercially exploit, or publicly display the standard or any portion thereof in any manner whatsoever without BSI's prior written consent.

Storing and using standards

Standards purchased in soft copy format:

- A British Standard purchased in soft copy format is licensed to a sole named user for personal or internal company use only.
- The standard may be stored on more than 1 device provided that it is accessible by the sole named user only and that only 1 copy is accessed at any one time.
- A single paper copy may be printed for personal or internal company use only.

Standards purchased in hard copy format:

- A British Standard purchased in hard copy format is for personal or internal company use only.
- It may not be further reproduced – in any format – to create an additional copy. This includes scanning of the document.

If you need more than 1 copy of the document, or if you wish to share the document on an internal network, you can save money by choosing a subscription product (see 'Subscriptions').

Reproducing extracts

For permission to reproduce content from BSI publications contact the BSI Copyright & Licensing team.

Subscriptions

Our range of subscription services are designed to make using standards easier for you. For further information on our subscription products go to bsigroup.com/subscriptions.

With **British Standards Online (BSOL)** you'll have instant access to over 55,000 British and adopted European and international standards from your desktop. It's available 24/7 and is refreshed daily so you'll always be up to date.

You can keep in touch with standards developments and receive substantial discounts on the purchase price of standards, both in single copy and subscription format, by becoming a **BSI Subscribing Member**.

PLUS is an updating service exclusive to BSI Subscribing Members. You will automatically receive the latest hard copy of your standards when they're revised or replaced.

To find out more about becoming a BSI Subscribing Member and the benefits of membership, please visit bsigroup.com/shop.

With a **Multi-User Network Licence (MUNL)** you are able to host standards publications on your intranet. Licences can cover as few or as many users as you wish. With updates supplied as soon as they're available, you can be sure your documentation is current. For further information, email subscriptions@bsigroup.com.

Revisions

Our British Standards and other publications are updated by amendment or revision.

We continually improve the quality of our products and services to benefit your business. If you find an inaccuracy or ambiguity within a British Standard or other BSI publication please inform the Knowledge Centre.

Useful Contacts

Customer Services

Tel: +44 345 086 9001

Email (orders): orders@bsigroup.com

Email (enquiries): cservices@bsigroup.com

Subscriptions

Tel: +44 345 086 9001

Email: subscriptions@bsigroup.com

Knowledge Centre

Tel: +44 20 8996 7004

Email: knowledgecentre@bsigroup.com

Copyright & Licensing

Tel: +44 20 8996 7070

Email: copyright@bsigroup.com

BSI Group Headquarters

389 Chiswick High Road London W4 4AL UK